

Large Current External FET Controller Type Switching Regulators

Single-output Step-up, High-efficiency Switching Regulator (Controller Type)

BD9763FVM

No.09028EAT07

●Description

BD9763FVM is a 1-channel high efficiency step-up switching regulator.

It is possible to choose small application space due to its high-speed operation (Max switching frequency 1.2MHz)

●Features

- 1) Build-in under voltage lock out circuit.
- 2) High accuracy reference voltage ($2.5V \pm 1.0\%$)
- 3) Establish maximum duty cycle internally.
- 4) CTL/SS terminal for both stand-by and soft-start function. (Soft-start time can be set by external capacitor)
- 5) MSOP8 thin and small package.

●Applications

Single-lens reflex cameras, digital video cameras, liquid crystal modules, DVD drive.

●Absolute Maximum Ratings(Ta=25°C)

Parameter	Symbol	Limit	Unit
Supply voltage	Vcc	10	V
Storage temperature range	Tstg	-55 to +150	°C
Power dissipation	Pd	587 *	mW
Junction temperature	Tjmax	+150	°C

* IC mounted on a PCB board (70mm x 70mm x 1.6mm, glass epoxy).
Reduced by 4.7mW for each increase in Ta of 1°C over 25°C.

●Recommended Operating Conditions

Parameter	Symbol	Limit			Unit
		Min	Typ	Max	
Supply voltage	Vcc	4	7	9	V
Oscillating frequency	fosc	100	-	1200	kHz
Operating temperature range	Topr	-40	-	+85	°C

●Electrical characteristics (Unless otherwise specified, Ta=25°C, Vcc=7.0V)

Parameter	Symbol	Limits			Unit	Condition
		Min	Typ	Max		
【Oscillator】						
Oscillating frequency	fosc	522	600	678	kHz	R _{RT} =24kΩ
Frequency tolerance	FDV	-5	0	5	%	V _{CC} =4 to 9V
Swing voltage	Vpptr	—	0.5	—	V	
【Stand-by, Soft start】						
CTL/SS pin source current	ISS	-1.90	-1.00	-0.55	μA	V _{CTL/SS} =1.5V
CTL/SS pin clamp voltage	VSS	2.2	2.4	2.6	V	
CTL threshold voltage	VCTLTH	1.2	1.3	1.4	V	
【PWM comparator】						
0% threshold voltage	D0	1.5	1.6	1.7	V	
Maximum duty cycle	DMAX	80	90	99.5	%	
【Error amplifier】						
Threshold voltage	VIN	0.98	1.00	1.02	V	
Band width	BW	—	3.0	—	MHz	AV=0dB
Voltage gain	Av	—	70	—	dB	
Input bias current	IIB	-150	-70	—	nA	
Maximum output voltage	VCH	2.3	2.4	2.6	V	
Minimum output current	VCL	—	0.03	0.20	V	
Output source current	IOI	-3.1	-1.6	-1.0	mA	V _{FB} =1.0V
Output sink current	IOO	12	50	125	mA	V _{FB} =1.0V
【Reference voltage】						
Output voltage	VREF	2.475	2.500	2.525	V	I _{VREF} =0mA
Load regulation	ΔVREF _{lo}	-	-	10	mV	I _{VREF} =0 to -1mA
Output short current	IVREF	-45	-16	-1	mA	
【Whole device】						
Stand-by current	ICCS	420	610	960	μA	
Circuit current	ICCA	3.4	5.0	7.8	mA	No load
【Output】						
ON resistance	RON	0.9	2.5	8.0	Ω	
Output rise/fall time	Tr/Tf	—	20	—	nsec	Cout=1000pF
Output source current	IOUTSO	—	-0.80	—	A	Ta=-40 to 85°C, VCC=4 to 9V, OUT=0V, rush current
Output sink current	IOUTSI	—	0.85	—	A	Ta=-40 to 85°C, VCC=4 to 9V, OUT=VCC, rush current
【Under voltage lock out】						
Threshold voltage	VUT	3.7	3.8	3.9	V	Vcc sweep down
Hysteresis width	VUThy	0.05	0.10	0.15	V	

●Reference data (Unless otherwise specified, Ta=25°C)

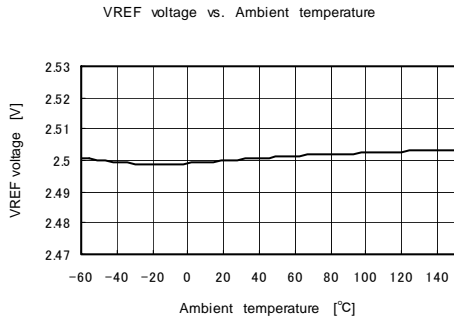

Fig.1 VREF voltage – Ambient temperature

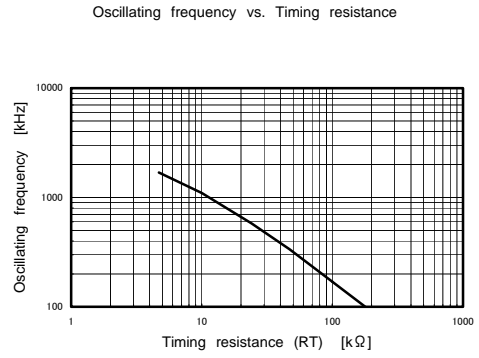

Fig.2 Oscillating frequency – Timing resistance (RRT)

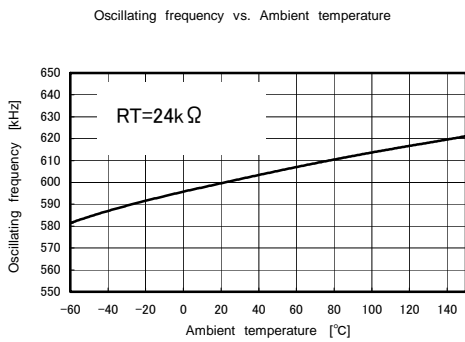

Fig.3 Oscillating frequency – Ambient temperature (RT=24kΩ)

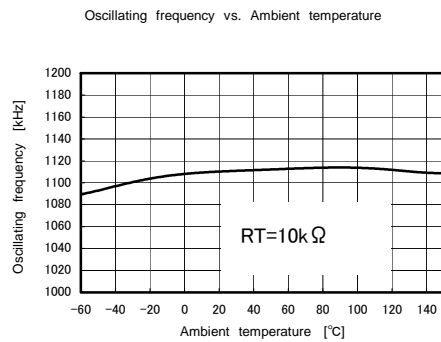

Fig.4 Oscillating frequency – Ambient temperature (RT=10kΩ)

●Block diagram

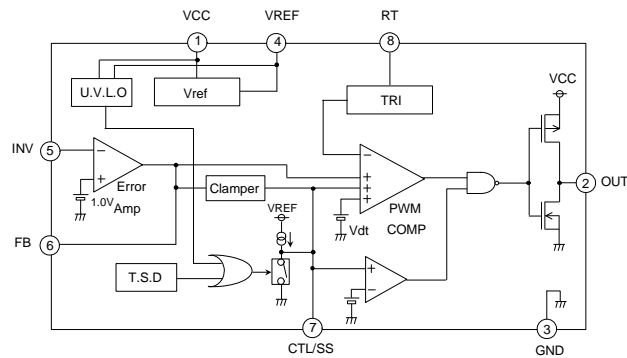

Fig.5

●Pin configuration

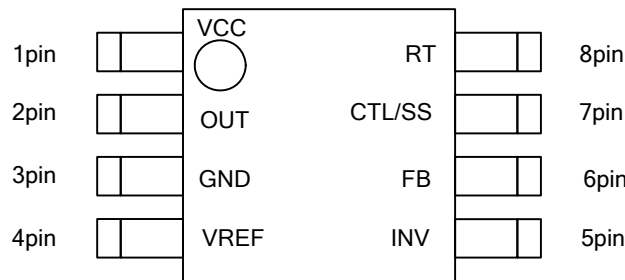

Fig.6

●Pin number , Pin name

Pin No.	Pin name	Function
1	VCC	Power supply
2	OUT	FET driver output
3	GND	Ground
4	VREF	Reference voltage (2.5V±1%) output
5	INV	Inverting input of error amplifier
6	FB	Output of error amplifier
7	CTL/SS	Stand-by switch/Soft start capacitor connecting pin
8	RT	Timing resistor connecting pin

●Block description

- VOLTAGE REFERENCE(VREF) BLOCK
This voltage reference block generates 2.5V internal reference voltage.
- OSCILLATOR BLOCK
Oscillator block sets the oscillating frequency adjusted by an external resistance in RT pin. The oscillating frequency can be set within a range of 100~1200kHz.. (See the description of how to set the frequency on page6.)
- PWM COMP
The PWM comparator transforms the voltage outputted from error amp to PWM waveform and outputs to FET driver. The maximum duty cycle is limited up to 90%.
- ERROR AMP BLOCK
The error amp block detects the output voltage from the INV pin, amplifies the difference between the detected voltage and the reference voltage, and outputs it to FB pin. The reference voltage is 1V±2%.
- PROTECTION CIRCUIT BLOCK
The under voltage lock out circuit is activated to shut down the whole circuit when the VCC voltage is up to 3.8V. When the thermal shutdown circuit detects abnormal heating of the chip (150°C), the output becomes off. And the output turns back on when the chip temperature goes down to a specific level.

●Application example

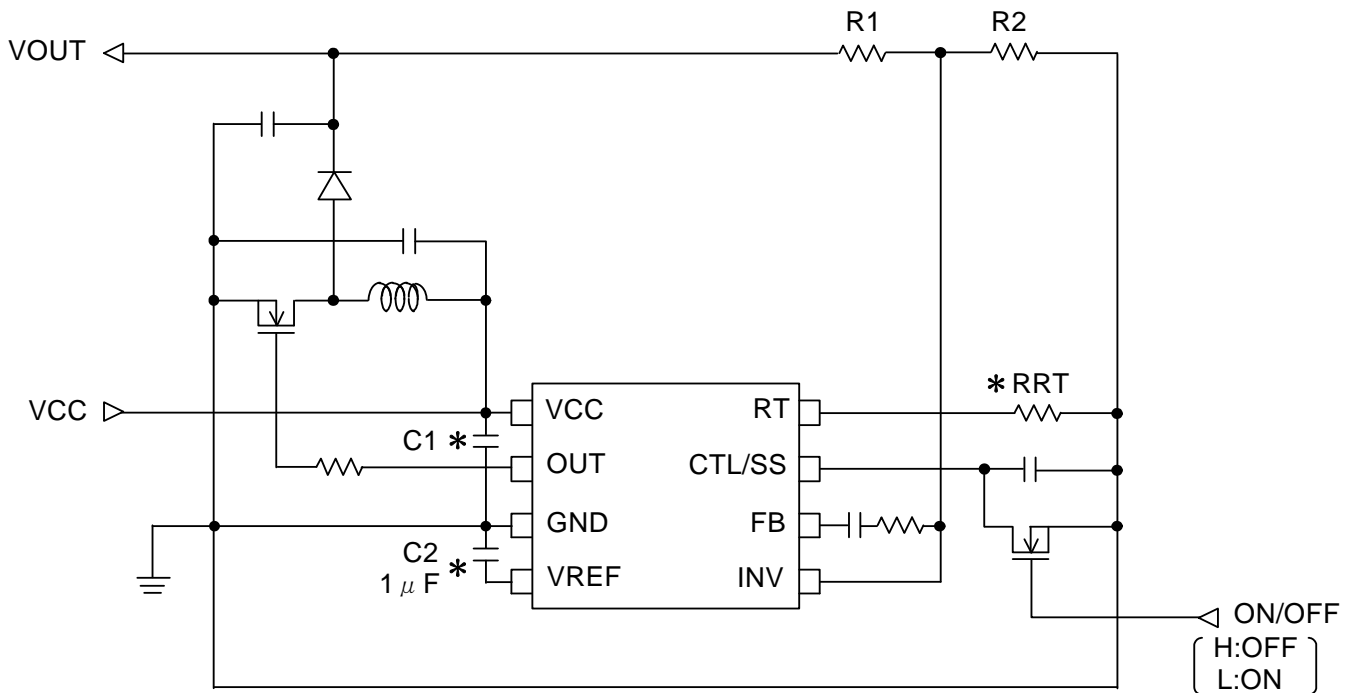

Fig.7

●Selecting application components

(1) Output inductor

It is recommended to use an inductor which satisfies the following rating current (the following value of current), and also has low DCR. The shield type inductor is preferable.

$$I_{peak} = I_o \cdot (V_o / V_{IN}) / \eta + V_{IN} \cdot (V_{OUT} - V_{IN}) / (2 \cdot V_{OUT} \cdot L \cdot f) \quad [A]$$

[I_o : Output V_o : Output voltage V_{IN} : Input voltage η : Efficiency L : Inductance f : Oscillating frequency]

(2) Output capacitor

It is recommended to use the output capacitor which has the enough margin to maximum rating for output voltage and low fluctuation for temperature. The ripple voltage of the output is influenced by ESR of the output capacitor.

$$V_{ripple} = V_{IN} \cdot (V_{OUT} - V_{IN}) / (V_{OUT} \cdot L \cdot f) \cdot ESR \quad [V]$$

$$(f \gg 1 / (2\pi \sqrt{LC}) \cdot V_o / V_{IN})$$

[I_o : Output V_o : Output voltage V_{IN} : Input voltage η : Efficiency L : Inductance C : Output capacitor f : Oscillating frequency]

(3) FET

It is recommended to use FETs which satisfy followings and have small Ciss or Qg and ON resistance.

D-S Voltage : Over (Output voltage + Vf of Di)

G-S Voltage : Over input voltage

D-S Current : Over Ipeak at the section of output inductor

(4) Diode

It is recommended to use a schottky diode which satisfies followings and has low forward voltage drop and high switching speed.

Maximum current : Over maximum output current

Direct reverse voltage : Over output voltage

* Please provide sufficient margin in the choice of external components by factoring into the worst case characteristics and temperature range.

(5) Setting the oscillator frequency

Refer to Fig.5 and determine Timing resistor (RRT) when setting the oscillating frequency.

Oscillating frequency vs. Timing resistance

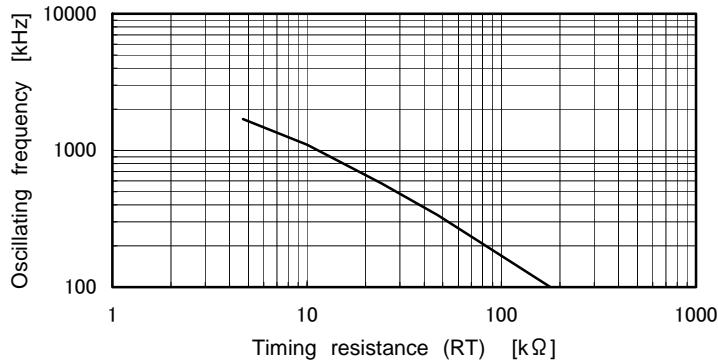

Fig.8 Oscillating frequency – Timing resistance (RRT)

(6) Setting the output voltage

The output voltage is calculated by the following equation.

$$V_o = V_{INth} \cdot (R1+R2)/R2 \quad [V]$$

R1,R2 : Resistor divider network

V_{INth} : Error amp threshold voltage (typ.1V)

(but $V_o < V_{IN} \cdot 5$ because of MAXDUTY Min=80%)

(7) CTL/SS setting the soft start time

The time after CTL/SS is released before the output voltage starts to rise.

$$t(start) = C_{CTL} \cdot (V_{Do} - V_{off}) / I_{ss} \quad [S] \quad \text{approximated equation}$$

The time after the output voltage starts up before it reaches the specified output level.

$$t(soft) = C_{CTL} \cdot (V_{DUTY} - V_{Do}) / I_{ss} \quad [S] \quad \text{approximated equation}$$

$$V_{DUTY} = V_{Do} + 0.5 \cdot (1 - V_{IN} / V_{OUT}) \quad [V]$$

C_{CTL} : CTL/SS–GND capacitance V_{Do} : 0% duty threshold (Typ 1.6V) V_{off} : Output off CTL/SS voltage

I_{ss} : CTL/SS charge current (Typ 1uA) V_{DUTY} : stabilization operating ON duty.

●Timing chart

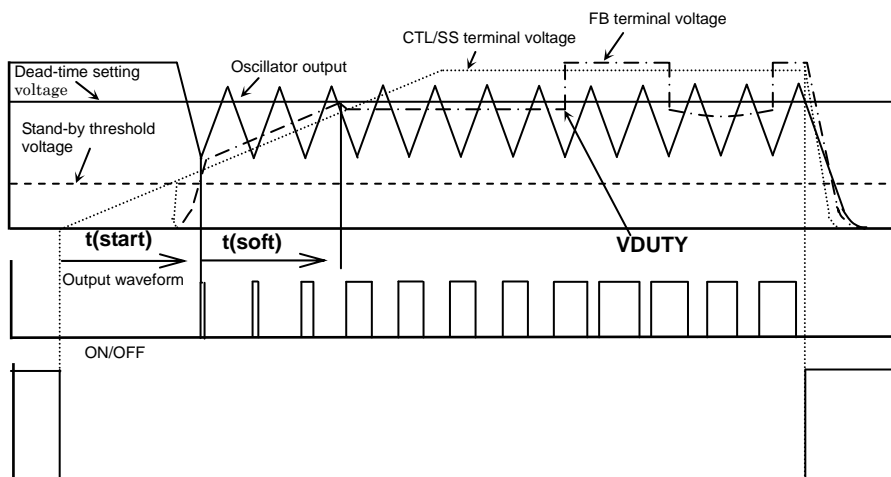
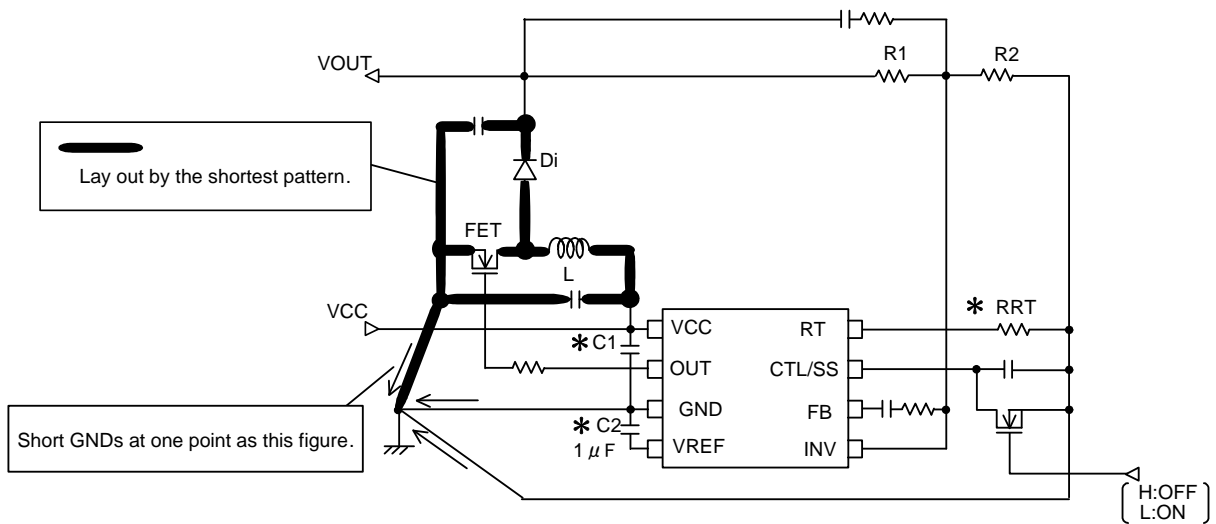

Fig.9

●Recommended board patterns



*Place these parts with attention about patterns shown in following Fig.7

Fig.10

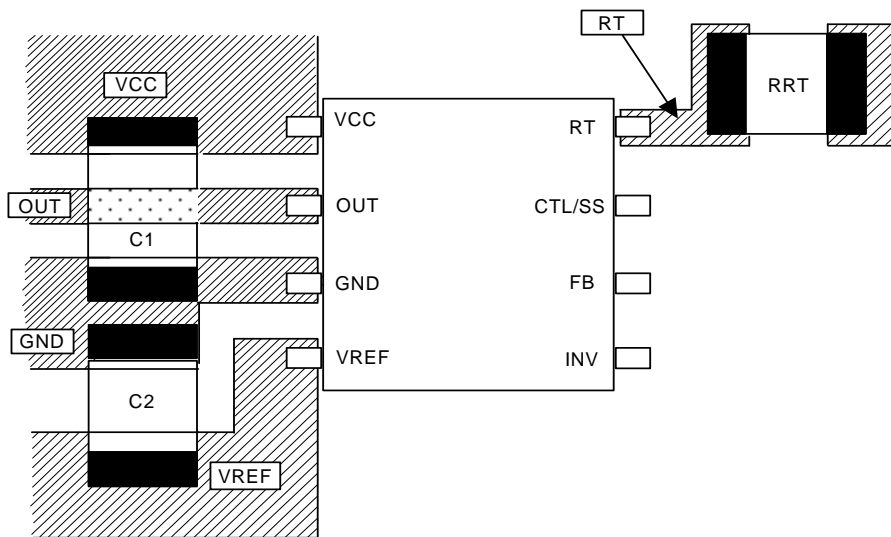

- C1 : Capacitor terminals have to be close enough to terminals of VCC and GND.
It is safe to pass OUT signal line under C1.
- C2 : Capacitor terminals have to be close enough to terminals of VREF and GND.
- R1 : Pattern area has to be small enough to reduce parasitic capacitance of RT terminal.

Fig.11 Recommended board patterns

● I/O Equivalent Circuit

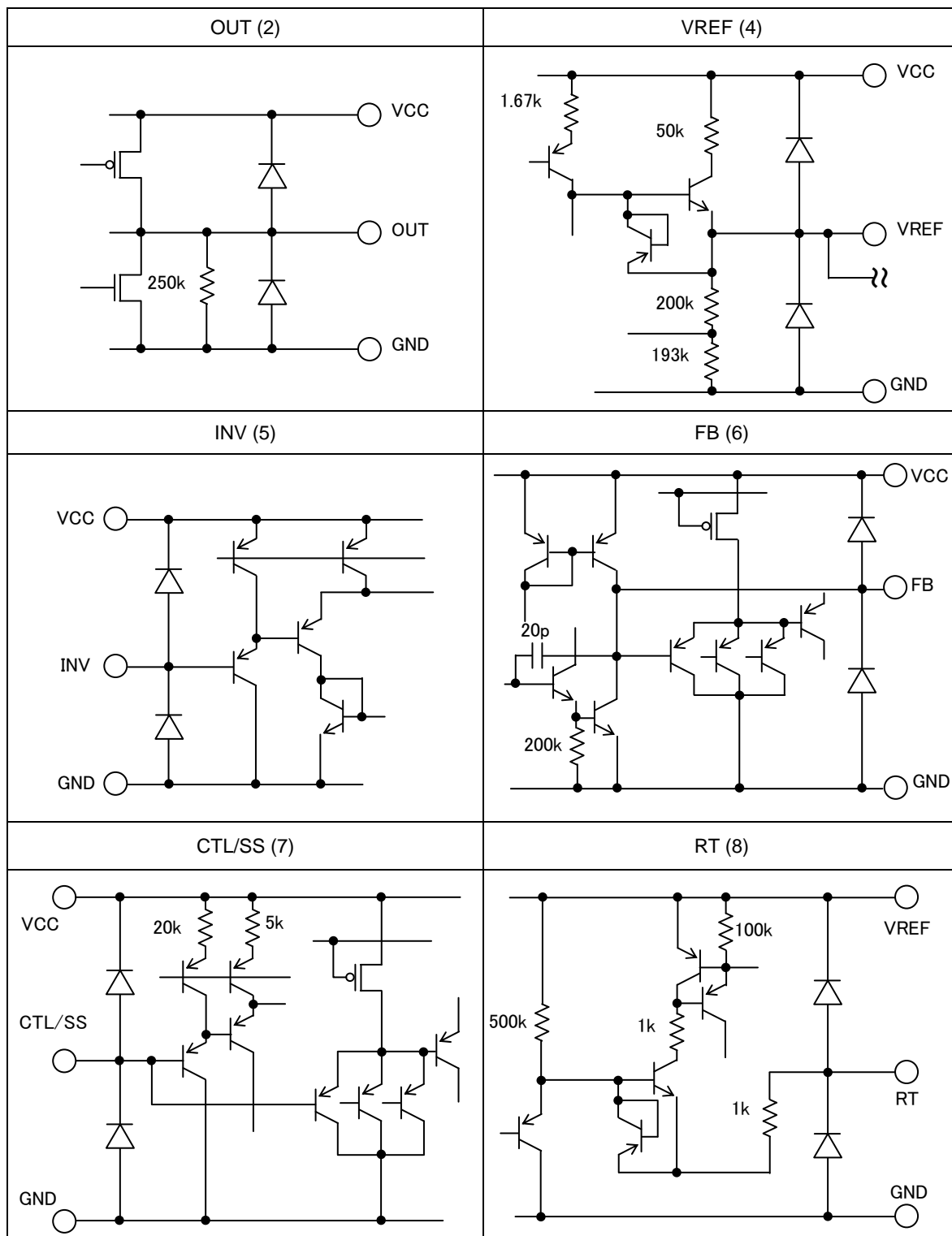

Fig.12

● Operation Notes

(1) Absolute maximum ratings

Use of the IC in excess of absolute maximum ratings such as the applied voltage or operating temperature range may result in IC deterioration or damage. Assumptions should not be made regarding the state of the IC (short mode or open mode) when such damage is suffered. A physical safety measure such as fuse should be implemented when use of the IC in a special mode where the absolute maximum ratings may be exceeded is anticipated.

(2) GND potential

Ensure a minimum GND pin potential in all operating conditions. In addition, ensure that no pins other than the GND pin. Carry a voltage lower than or equal to the GND pin, including during actual transient phenomena.

(3) Thermal design

Use a thermal design that allows for a sufficient margin in light of the power dissipation (P_d) in actual operating conditions.

(4) Inter-pin shorts and mounting errors

Use caution when orienting and positioning the IC for mounting on printed circuit boards. Improper mounting may result in damage to the IC. Shorts between output pins or between output pins and the power supply and GND pin caused by the presence of a foreign object may result in damage to the IC.

(5) Operation in a strong electromagnetic field

Use caution when using the IC in the presence of a strong electromagnetic field as doing so may cause the IC to malfunction.

(6) Thermal shutdown circuit (TSD circuit)

This IC incorporates a built-in thermal shutdown circuit (TSD circuit). The TSD circuit designed only to shut the IC off to prevent runaway thermal operation.

do not continue to use the IC after operating this circuit or use the IC in an environment where the operation of the thermal shutdown circuit is assumed.

(7) Testing on application boards

When testing the IC on an application board, connecting a capacitor to pin with low impedance subjects the IC to stress. Always discharge capacitors after each process or step. Ground the IC during assembly steps as an antistatic measure, and use similar caution when transporting or storing the IC. Always turn the IC's power supply off before connecting it to or removing it from a jig or fixture the inspection process.

(8) Common impedance

Power supply and ground wiring should reflect consideration of the need to lower common impedance and minimize ripple as much as possible (by making wiring as short and thick as possible or rejecting ripple by incorporating inductance and capacitance).

(9) Applications with modes that reverse VCC and pin potentials may cause damage to internal IC circuits.

For example, such damage might occur when VCC is shorted with the GND pin while an external capacitor is charged. It is recommended to insert a diode for preventing back current flow in series with VCC or bypass diodes between VCC and each pin.

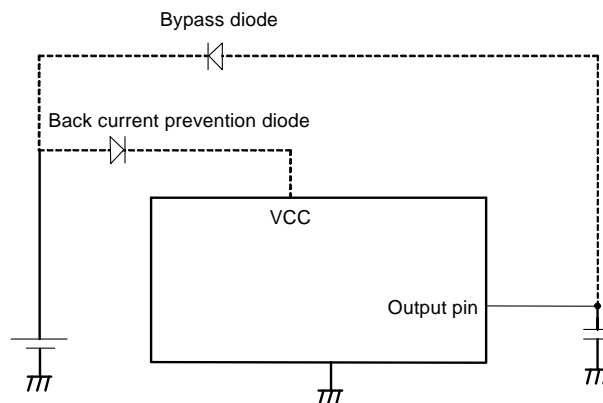

Fig.13

(10) Timing resistor

Timing resistor connected between RT and GND, has to be placed near RT terminal (8pin). And pattern has to be short Enough.

(11) IC pin input

This monolithic IC contains P + isolation and PCB layers between adjacent elements in order to keep them isolated. P/N junctions are formed at the intersection of these P layers with the N layers of other elements to create a variety of parasitic elements.

For example, when a resistor and transistor are connected to pins as shown in Fig.14,

○The P/N junction functions as a parasitic diode when $GND > (Pin A)$ for the resistor or $GND > (Pin B)$ for the transistor (NPN).

○Similarly, when $GND > (Pin B)$ for the transistor (NPN), the parasitic diode described above combines

With the N layer of other adjacent elements to operate as a parasitic NPN transistor.

The formation of parasitic elements as a result of the relationships of the potentials of different pins is an inevitable result of the IC's architecture. The operation of parasitic elements can cause interference with circuit operation as well as IC malfunction and damage. For these reasons, it is necessary to use caution so that the IC is not used in a way that will trigger the operation of parasitic elements, such as by the application of voltage lower than the GND (PCB) voltage to input and output pins.

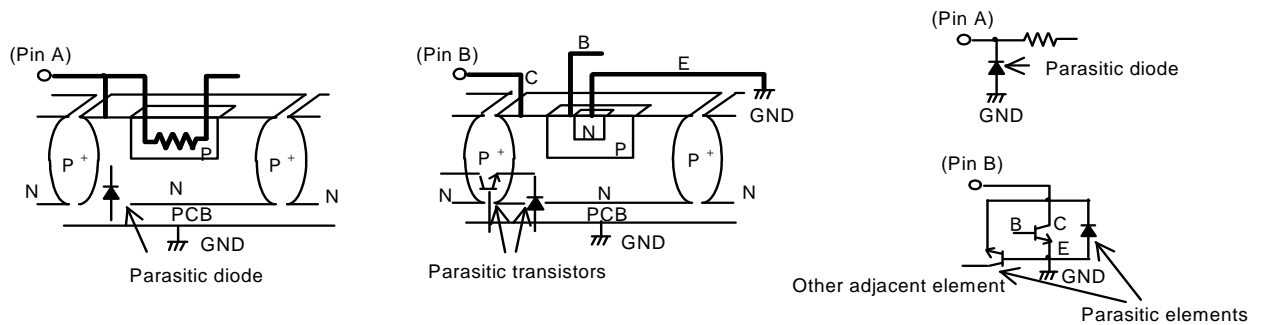
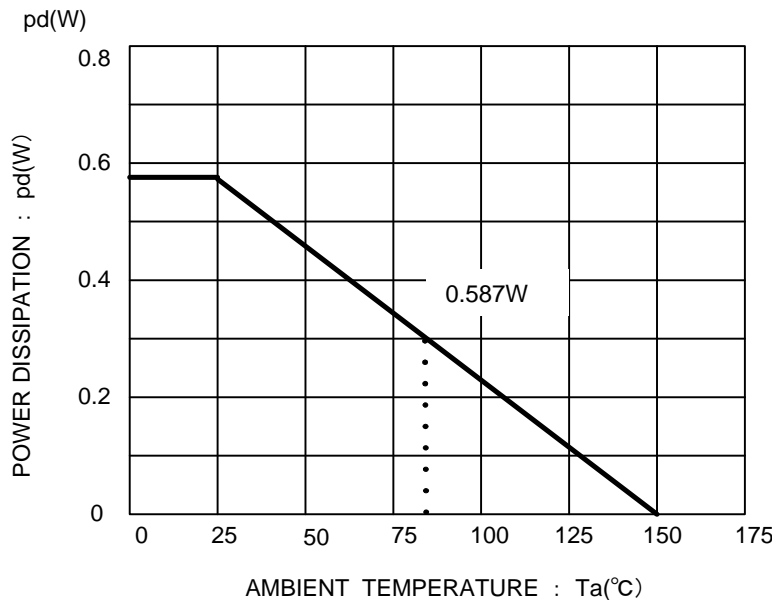

Fig.14

●Power Dissipation Reduction



IC mounted on a ROHM standard board (70mm x 70mm x 1.6mm, glass epoxy)

Fig.15

●Ordering part number

B	D
---	---

Part No.

9	7	6	3
---	---	---	---

Part No.

F	V	M
---	---	---

Package
FVM: MSOP8

T	R
---	---

Packaging and forming specification
TR: Embossed tape and reel
(MSOP8)

MSOP8

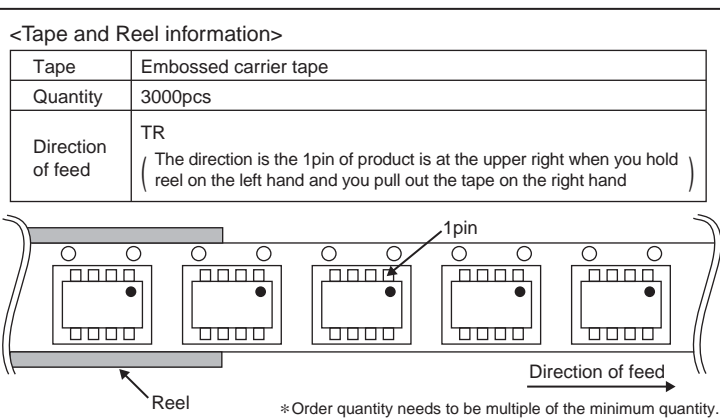
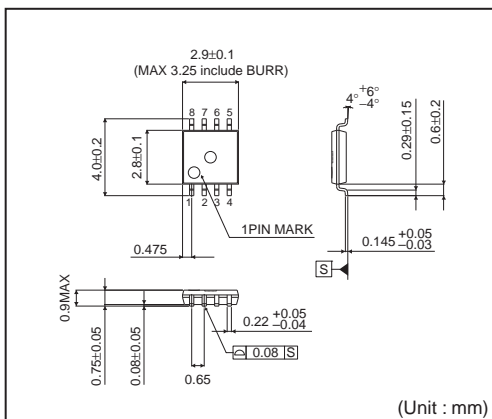

Notice

Precaution on using ROHM Products

- Our Products are designed and manufactured for application in ordinary electronic equipments (such as AV equipment, OA equipment, telecommunication equipment, home electronic appliances, amusement equipment, etc.). If you intend to use our Products in devices requiring extremely high reliability (such as medical equipment ^(Note 1), transport equipment, traffic equipment, aircraft/spacecraft, nuclear power controllers, fuel controllers, car equipment including car accessories, safety devices, etc.) and whose malfunction or failure may cause loss of human life, bodily injury or serious damage to property ("Specific Applications"), please consult with the ROHM sales representative in advance. Unless otherwise agreed in writing by ROHM in advance, ROHM shall not be in any way responsible or liable for any damages, expenses or losses incurred by you or third parties arising from the use of any ROHM's Products for Specific Applications.

(Note1) Medical Equipment Classification of the Specific Applications

JAPAN	USA	EU	CHINA
CLASS III	CLASS III	CLASS II b	CLASS III
CLASS IV		CLASS III	

- ROHM designs and manufactures its Products subject to strict quality control system. However, semiconductor products can fail or malfunction at a certain rate. Please be sure to implement, at your own responsibilities, adequate safety measures including but not limited to fail-safe design against the physical injury, damage to any property, which a failure or malfunction of our Products may cause. The following are examples of safety measures:
 - Installation of protection circuits or other protective devices to improve system safety
 - Installation of redundant circuits to reduce the impact of single or multiple circuit failure
- Our Products are designed and manufactured for use under standard conditions and not under any special or extraordinary environments or conditions, as exemplified below. Accordingly, ROHM shall not be in any way responsible or liable for any damages, expenses or losses arising from the use of any ROHM's Products under any special or extraordinary environments or conditions. If you intend to use our Products under any special or extraordinary environments or conditions (as exemplified below), your independent verification and confirmation of product performance, reliability, etc. prior to use, must be necessary:
 - Use of our Products in any types of liquid, including water, oils, chemicals, and organic solvents
 - Use of our Products outdoors or in places where the Products are exposed to direct sunlight or dust
 - Use of our Products in places where the Products are exposed to sea wind or corrosive gases, including Cl₂, H₂S, NH₃, SO₂, and NO₂
 - Use of our Products in places where the Products are exposed to static electricity or electromagnetic waves
 - Use of our Products in proximity to heat-producing components, plastic cords, or other flammable items
 - Sealing or coating our Products with resin or other coating materials
 - Use of our Products without cleaning residue of flux (even if you use no-clean type fluxes, cleaning residue of flux is recommended); or Washing our Products by using water or water-soluble cleaning agents for cleaning residue after soldering
 - Use of the Products in places subject to dew condensation
- The Products are not subject to radiation-proof design.
- Please verify and confirm characteristics of the final or mounted products in using the Products.
- In particular, if a transient load (a large amount of load applied in a short period of time, such as pulse. is applied, confirmation of performance characteristics after on-board mounting is strongly recommended. Avoid applying power exceeding normal rated power; exceeding the power rating under steady-state loading condition may negatively affect product performance and reliability.
- De-rate Power Dissipation (Pd) depending on Ambient temperature (Ta). When used in sealed area, confirm the actual ambient temperature.
- Confirm that operation temperature is within the specified range described in the product specification.
- ROHM shall not be in any way responsible or liable for failure induced under deviant condition from what is defined in this document.

Precaution for Mounting / Circuit board design

- When a highly active halogenous (chlorine, bromine, etc.) flux is used, the residue of flux may negatively affect product performance and reliability.
- In principle, the reflow soldering method must be used; if flow soldering method is preferred, please consult with the ROHM representative in advance.

For details, please refer to ROHM Mounting specification

Precautions Regarding Application Examples and External Circuits

1. If change is made to the constant of an external circuit, please allow a sufficient margin considering variations of the characteristics of the Products and external components, including transient characteristics, as well as static characteristics.
2. You agree that application notes, reference designs, and associated data and information contained in this document are presented only as guidance for Products use. Therefore, in case you use such information, you are solely responsible for it and you must exercise your own independent verification and judgment in the use of such information contained in this document. ROHM shall not be in any way responsible or liable for any damages, expenses or losses incurred by you or third parties arising from the use of such information.

Precaution for Electrostatic

This Product is electrostatic sensitive product, which may be damaged due to electrostatic discharge. Please take proper caution in your manufacturing process and storage so that voltage exceeding the Products maximum rating will not be applied to Products. Please take special care under dry condition (e.g. Grounding of human body / equipment / solder iron, isolation from charged objects, setting of ionizer, friction prevention and temperature / humidity control).

Precaution for Storage / Transportation

1. Product performance and soldered connections may deteriorate if the Products are stored in the places where:
 - [a] the Products are exposed to sea winds or corrosive gases, including Cl₂, H₂S, NH₃, SO₂, and NO₂
 - [b] the temperature or humidity exceeds those recommended by ROHM
 - [c] the Products are exposed to direct sunshine or condensation
 - [d] the Products are exposed to high Electrostatic
2. Even under ROHM recommended storage condition, solderability of products out of recommended storage time period may be degraded. It is strongly recommended to confirm solderability before using Products of which storage time is exceeding the recommended storage time period.
3. Store / transport cartons in the correct direction, which is indicated on a carton with a symbol. Otherwise bent leads may occur due to excessive stress applied when dropping of a carton.
4. Use Products within the specified time after opening a humidity barrier bag. Baking is required before using Products of which storage time is exceeding the recommended storage time period.

Precaution for Product Label

QR code printed on ROHM Products label is for ROHM's internal use only.

Precaution for Disposition

When disposing Products please dispose them properly using an authorized industry waste company.

Precaution for Foreign Exchange and Foreign Trade act

Since our Products might fall under controlled goods prescribed by the applicable foreign exchange and foreign trade act, please consult with ROHM representative in case of export.

Precaution Regarding Intellectual Property Rights

1. All information and data including but not limited to application example contained in this document is for reference only. ROHM does not warrant that foregoing information or data will not infringe any intellectual property rights or any other rights of any third party regarding such information or data. ROHM shall not be in any way responsible or liable for infringement of any intellectual property rights or other damages arising from use of such information or data.:
2. No license, expressly or implied, is granted hereby under any intellectual property rights or other rights of ROHM or any third parties with respect to the information contained in this document.

Other Precaution

1. This document may not be reprinted or reproduced, in whole or in part, without prior written consent of ROHM.
2. The Products may not be disassembled, converted, modified, reproduced or otherwise changed without prior written consent of ROHM.
3. In no event shall you use in any way whatsoever the Products and the related technical information contained in the Products or this document for any military purposes, including but not limited to, the development of mass-destruction weapons.
4. The proper names of companies or products described in this document are trademarks or registered trademarks of ROHM, its affiliated companies or third parties.

General Precaution

1. Before you use our Products, you are requested to carefully read this document and fully understand its contents. ROHM shall not be in any way responsible or liable for failure, malfunction or accident arising from the use of any ROHM's Products against warning, caution or note contained in this document.
2. All information contained in this document is current as of the issuing date and subject to change without any prior notice. Before purchasing or using ROHM's Products, please confirm the latest information with a ROHM sales representative.
3. The information contained in this document is provided on an "as is" basis and ROHM does not warrant that all information contained in this document is accurate and/or error-free. ROHM shall not be in any way responsible or liable for any damages, expenses or losses incurred by you or third parties resulting from inaccuracy or errors of or concerning such information.

Looking for pricing, stock, or lifecycle information?

Click below to explore more details on WIN SOURCE:

-  [View BD9763FVM-TR on WIN SOURCE](#)
-  [Rohm Semiconductor](#) Information

Optimize Your Supply Chain with WIN SOURCE Solutions

-  Global Sourcing Solution
-  Obsolete Management
-  Cost Control Management
-  Shortage Management
-  Alternative Solution
-  Excess Inventory Management