



**THE DATASHEET OF
BD9851EFV-E2**



Large Current External FET Controller Type Switching Regulators

Single-output High-frequency Step-down Switching Regulator(Controller type)

BD9850FVM

Dual-output Step-up, Negative, Step-down Switching Regulator(Controller type)

BD9851EFV



● Description

The BD9850FVM is a 1-channel DC/DC step-down switching regulator controller, while the BD9851EFV is a 2-channel DC/DC step-down switching regulator controller. The BD9850FVM is adaptable for a maximum switching frequency of 2 MHz and the BD9851EFV for that of 3 MHz. Both provide space saving in all applications.

● Features

- 1) Adaptable for 2-MHz switching frequency (externally variable) (BD9850FVM)
Adaptable for 3-MHz switching frequency (externally variable) (BD9851EFV)
- 2) FET direct drive
- 3) High-accuracy reference voltage (Accuracy: $\pm 1\%$)
- 4) Built-in Under Voltage Lock Out circuit (UVLO)
- 5) Built-in Thermal Shutdown circuit (TSD)
- 6) The BD9851EFV provides two channels:
Channel 1 available for selection of step-down/step-up switching
Channel 2 available for selection of step-down/inverting switching.
- 7) Compact MSOP8 package (BD9850FVM) / HTSSOP-B20 package (BD9851EFV)

● Applications

TFT panel, TA/ Router, digital consumer electronics, PC, and portable CD/ DVD/ DVC

● Product lineup

| | BD9850FVM | BD9851EFV |
|-----------------------------|----------------|---------------|
| Input range | 4V to 9V | 4V to 18V |
| Oscillation frequency range | 100kHz to 2MHz | 10kHz to 3MHz |
| External synchronization | Not provided | Not provided |
| Standby function | Not provided | Provided |
| Operating temperature | -40°C to 85°C | -40°C to 85°C |
| Package | MSOP8 | HTSSOP-B20 |

● **Absolute maximum ratings** (Ta=25°C)

○ BD9850FVM

| Item | Symbol | Rating | Unit |
|------------------------------|--------|-------------|------|
| Power supply voltage | Vcc | 10 | V |
| Storage temperature | Tstg | -55 to +150 | °C |
| Operating temperature | Topr | -40 to +85 | °C |
| Power dissipation | Pd | 587 | mW |
| Maximum junction temperature | Tjmax | +150 | °C |

Reduce by 4.7 mW/°C over 25°C (When mounted on PCB of 70mm×70mm×1.6mm)

○ BD9851EFV

| Item | Symbol | Rating | Unit |
|--|--------|---------------------|------|
| Power supply voltage (Between Vcc and GND) | Vcc | 20 | V |
| Between VREF and GND | VREF | 7 | V |
| Between OUT1 and PVcc1 Between OUT2 and PVcc2 | Vouth | 20 | V |
| Between OUT1, OUT2 and PGND | Voutl | 20 | V |
| Power dissipation | Pd | 1000 ^() | mW |
| Operating temperature | Topr | -40 to +85 | °C |
| Maximum junction temperature | Tjmax | +150 | °C |
| Storage temperature | Tstg | -55 to +150 | °C |

() Reduce by 8.0 mW/°C over 25°C (When mounted on PCB of 70mm×70mm×1.6mm)

● **Recommended operating range**

○ BD9850FVM

| Item | Symbol | Limits | | | Unit |
|-----------------------|--------|--------|------|------|------|
| | | min. | Typ. | max. | |
| Power supply voltage | Vcc | 4 | 7 | 9 | V |
| Oscillation frequency | fosc | 100 | - | 2000 | kHz |
| Operating temperature | Topr | -40 | - | +85 | °C |

○ BD9851EFV

| Item | Symbol | Limits | | | Unit |
|-----------------------|--------|--------|------|-------|------|
| | | min. | Typ. | max. | |
| Power supply voltage | Vcc | 4 | 12 | 18 | V |
| Oscillation frequency | fosc | 10 | 300 | 3000 | kHz |
| Timing resistor | RRT | 3.3 | - | 47 | kΩ |
| Timing capacitor | CCT | 33 | - | 10000 | pF |

Electrical characteristics (Unless otherwise specified, Ta=25°C, Vcc=7V, fosc=600kHz)

| Item | Symbol | Limits | | | Unit | Conditions |
|-------------------------------|---------|--------|-------|-------|------|---------------------|
| | | min. | Typ. | max. | | |
| [Oscillator block] | | | | | | |
| Oscillation frequency | fosc | 510 | 600 | 690 | kHz | RRT = 24kΩ |
| Frequency regulation | FDV | -5 | 0 | 5 | % | Vcc = 4V to 9V |
| Oscillator amplitude voltage | Vpptr | - | 0.5 | - | V | |
| [Soft start/SW block] | | | | | | |
| CTL/SS pin sink current | ISS | -1.90 | -1.00 | 1.00 | μA | VCTL/SS = 1.5V |
| CTL/SS pin clamp voltage | VSS | 2.2 | 2.4 | 2.6 | V | |
| CTL threshold voltage | VCTLTH | 1.2 | 1.3 | 1.4 | V | |
| [PWM comparator block] | | | | | | |
| 0% threshold voltage | D0 | 1.5 | 1.6 | 1.7 | V | fosc = 600kHz |
| 100% threshold voltage | D100 | 2.0 | 2.1 | 2.2 | V | fosc = 600kHz |
| [Error Amp block] | | | | | | |
| Threshold voltage | VIN | 0.98 | 1.00 | 1.02 | V | AV = 0dB |
| Frequency bandwidth | BW | 1.5 | 3.0 | - | MHz | |
| Voltage gain | Av | - | 70 | - | dB | |
| Input bias current | IIB | -150 | -70 | - | A | |
| Maximum output voltage | VCH | 2.3 | 2.4 | 2.6 | V | |
| Minimum output voltage | VCL | - | 0.03 | 0.20 | V | |
| Output source current | IOI | -3.1 | -1.6 | -1.0 | mA | VFB = 1.0V |
| Output sink current | IOO | 12 | 50 | 125 | mA | VFB = 1.0V |
| [VREF block] | | | | | | |
| VREF output voltage | VREF | 2.475 | 2.500 | 2.525 | V | IVREF = 0mA |
| FREF load regulation | ΔVREFIO | - | - | 10 | mV | IVREF = 0mA to -1mA |
| VREF current capacitance | IVREF | -45 | -16 | -1 | mA | |
| [Total device] | | | | | | |
| Standby current | ICCS | 420 | 610 | 960 | μA | |
| Average supply current | ICCA | 3.4 | 5.0 | 7.8 | mA | At no load |
| [Output block] | | | | | | |
| ON resistance | RON | 0.9 | 2.5 | 8.0 | Ω | |
| Output transient time | Tr/Tf | - | 20 | - | nsec | Cout = 1000pF |
| [Under voltage lockout block] | | | | | | |
| Threshold voltage | VUT | 3.7 | 3.8 | 3.9 | V | Vcc sweep down |
| Hysteresis width | VUThy | 0.05 | 0.10 | 0.15 | V | |

Design guarantee

Not designed to be radiation-resistant.

Electrical characteristics (Unless otherwise specified, Ta=25°C, Vcc=12V, fosc=300kHz, STB=3V)

| Item | Symbol | Limits | | | Unit | Conditions |
|--|---------|----------|-------|-------|------|------------------------|
| | | min. | Typ. | max. | | |
| [Total device] | | | | | | |
| Standby mode circuit current | Iccst | – | – | 5 | μA | STB=0V |
| Operation mode circuit current | Icc | 1.5 | 2.5 | 4.1 | mA | FB1, FB2=0V |
| [Reference voltage block] | | | | | | |
| Output voltage | VREF | 2.475 | 2.500 | 2.525 | V | Io=–0.1mA |
| Input stability | DVli | – | – | 10 | mV | Vcc=4Vto18V, Io=–0.1mA |
| Load stability | DVlo | – | – | 10 | mV | Io=–0.1mA to –1mA |
| Short circuit mode output current | Ios | –45 | –12 | –3 | mA | |
| [Oscillator block] | | | | | | |
| Oscillation frequency | fosc | 270 | 300 | 330 | kHz | RRT=24kΩ, CCT=220pF |
| Oscillation frequency regulation | Dfosc | –2 | 0 | 2 | % | Vcc=4Vto18V |
| [Error Amp block] | | | | | | |
| Threshold voltage | Vthea | 0.98 | 1.00 | 1.02 | V | Ch1 |
| Input offset voltage | Vofst | –10 | 0 | 10 | mV | Ch2 |
| Common-mode input voltage range | Vcm | 0.3 | – | 2.0 | V | Ch2 |
| Input bias current | Ibias | –150 | –70 | – | nA | |
| Voltage gain | Av | 60 | 75 | 90 | dB | DC Design guarantee |
| Frequency bandwidth | Bw | 3 | 6 | 13 | MHz | MHz Design guarantee |
| Maximum output voltage | Vfbh | VREF–0.1 | – | VREF | V | |
| Minimum output voltage | Vfbl | – | – | 0.1 | V | |
| Output sink current | Isink | 1.6 | 6 | 16 | mA | FB pin |
| Output source current | Isource | –260 | –160 | –90 | μA | FB pin |
| [PWM comparator block] | | | | | | |
| 0% threshold voltage | Vth0 | 1.21 | 1.31 | 1.41 | V | FB voltage |
| 100% threshold voltage | Vth100 | 1.74 | 1.84 | 1.94 | V | FB voltage |
| DTC bias current | Idtc | –1 | – | 1 | μA | |
| [FET driver block] | | | | | | |
| ON resistance | RONN | 1.5 | 3 | 3 | Ω | When OUT=Lo |
| | RONP | 1 | 2 | 2 | Ω | When OUT=Hi |
| SEL1 input voltage range | Vselh | Vcc–0.2 | – | – | V | In step-down switching |
| | Vsell | 0 | – | – | V | In step-down switching |
| [Control block] | | | | | | |
| Threshold voltage | Vstb | 0.6 | 1.5 | 1.5 | V | |
| Sink current | Istb | 6 | 15 | 15 | μA | STB=3V |
| [Short circuit protection circuit (SCP) block] | | | | | | |
| Timer start voltage | Vtime | 2.2 | 2.3 | 2.3 | V | FB voltage |
| Threshold voltage | Vthscp | 1.4 | 1.5 | 1.5 | V | SCP voltage |
| Standby mode voltage | Vstscp | – | 10 | 10 | mV | SCP voltage |
| Source current | Vsoscsp | –3.2 | –2.0 | –2.0 | μA | SCP=0.75V |
| [Under voltage lockout block (UVLO)] | | | | | | |
| Threshold voltage | Vuvlo | 3.58 | 3.7 | 3.7 | V | Vcc sweep down |
| Hysteresis width | DVuvlo | 0.05 | 0.11 | 0.11 | V | |

Design guarantee

● **Characteristic data**
(BD9850FVM)

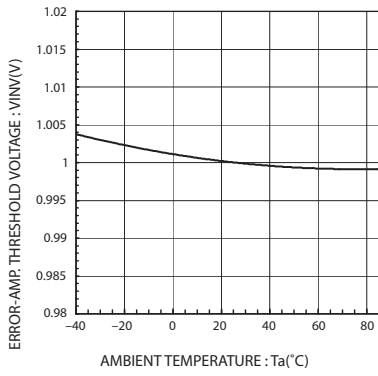

Fig.1 Error Amp threshold voltage vs. Ambient temperature

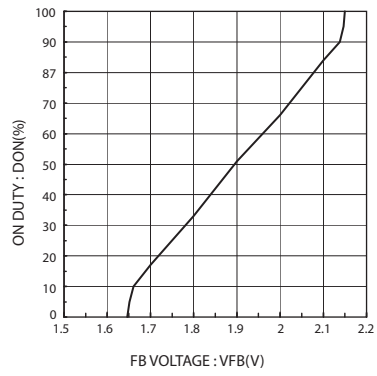

Fig.2 FB voltage vs. ON Duty

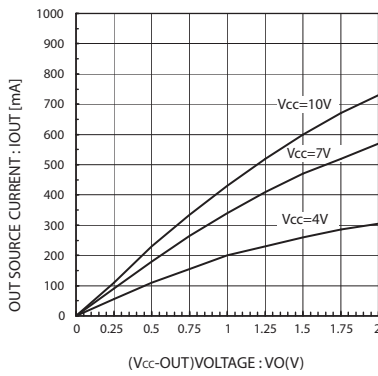

Fig.3 (Vcc-OUT) Voltage vs. Output source current

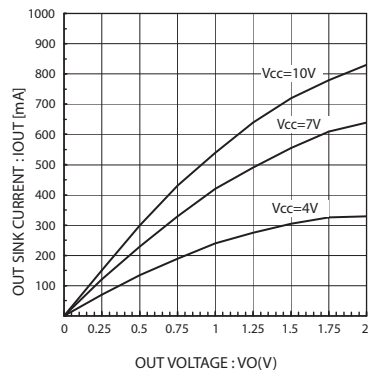

Fig.4 Output voltage vs. Output sink current

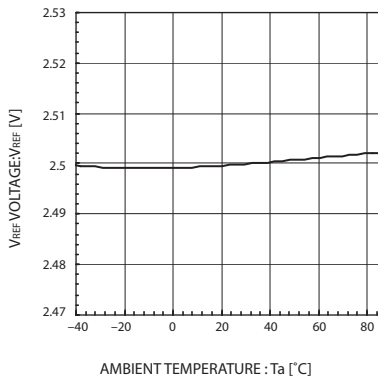

Fig.5 VREF vs. Ambient temperature

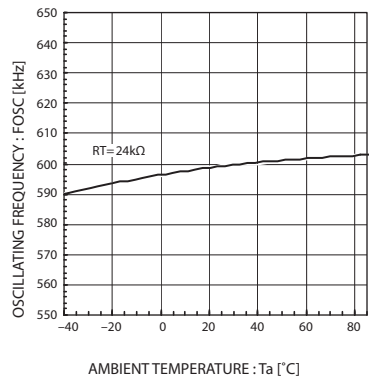

Fig.6 Oscillation frequency vs. Ambient temperature

(BD9851EFV)

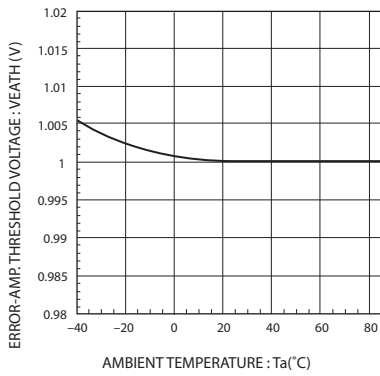

Fig.7 Error Amp threshold voltage vs. Ambient temperature

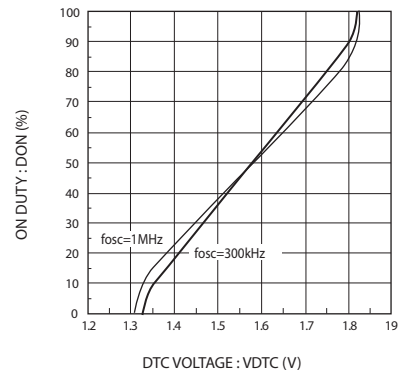

Fig.8 FB voltage vs. ON Duty

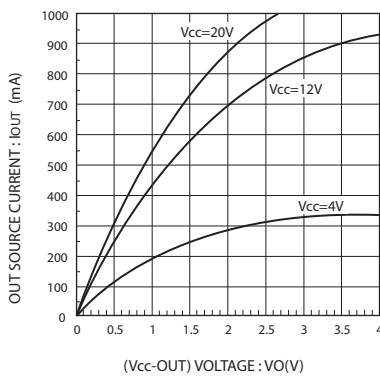

Fig.9 (Vcc-OUT) Voltage vs. Output source current

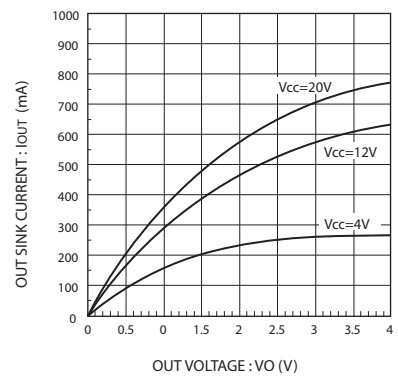

Fig.10 Output voltage vs. Output sink current

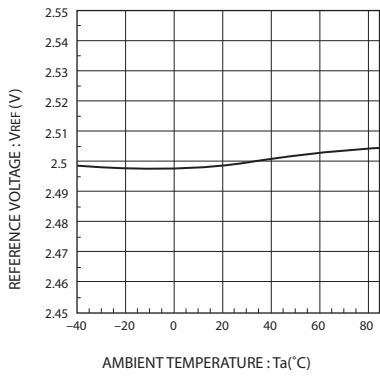

Fig.11 VREF vs. Ambient temperature

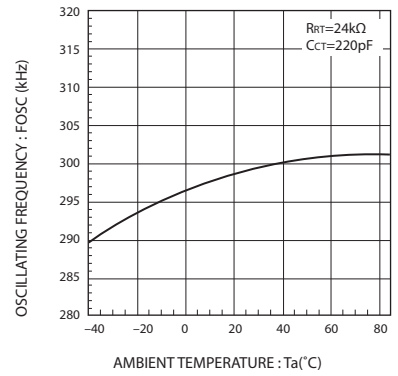

Fig.12 Oscillation frequency vs. Ambient temperature

● Block diagram / Pin assignment

(BD9850FVM)

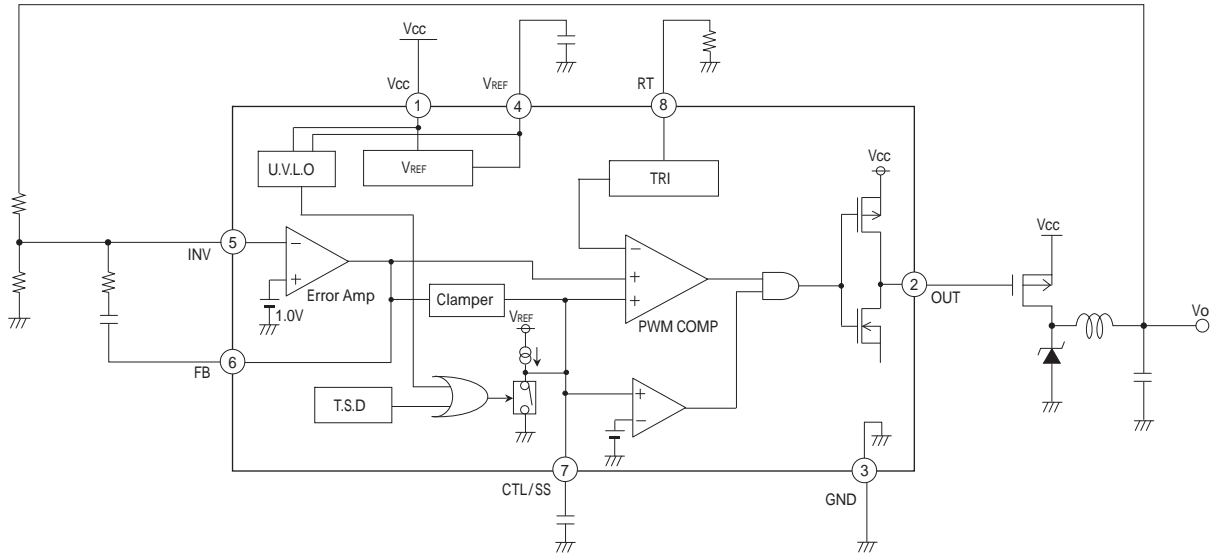
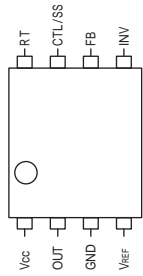

Fig.13 BD9850FVM Block diagram



| Pin No. | Pin name | Function |
|---------|----------|---|
| 1 | Vcc | Power supply |
| 2 | OUT | FET driver drive output |
| 3 | GND | Ground |
| 4 | VREF | Reference voltage (2.5V±1%) output |
| 5 | INV | Error Amp inverting input |
| 6 | FB | Error Amp output |
| 7 | CTL/SS | Control/Soft start common |
| 8 | RT | Oscillation frequency setting resistor connection |

(BD9851EFV)

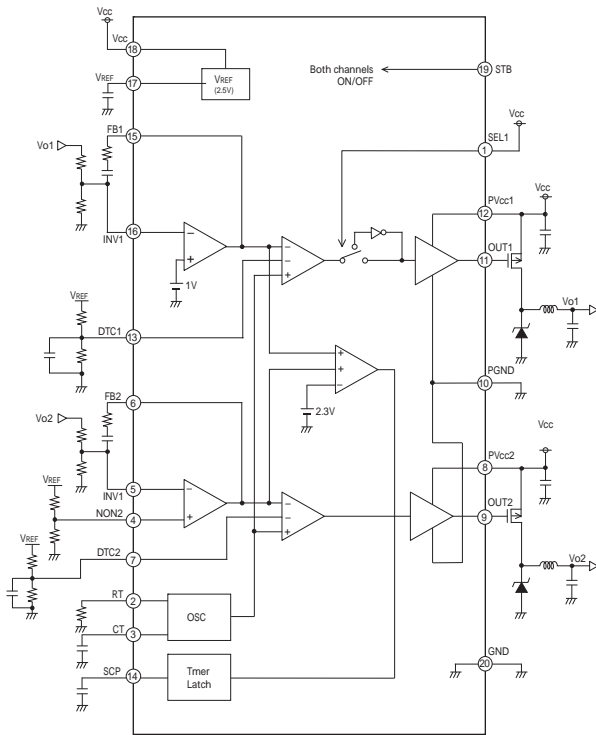
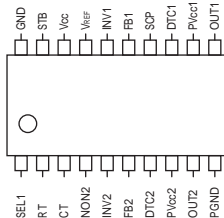

Fig.14 BD9851EFV Block diagram



| Pin No. | Pin name | Function |
|---------|----------------|---|
| 1 | SEL1 | CH1 drive FET setting (Vcc short: P-ch drive, GND short: N-ch drive) |
| 2 | RT | Oscillation frequency setting resistor connection |
| 3 | CT | Oscillation frequency setting capacitor connection |
| 4 | NON2 | Error Amp non-inverting input (CH2) |
| 5 | INV2 | Error Amp inverting input (CH2) |
| 6 | FB2 | Error Amp output (CH2) |
| 7 | DTC2 | Maximum duty/soft start setting (CH2) |
| 8 | PVcc2 | FET driver block power supply input (CH2) |
| 9 | OUT2 | FET driver block output (CH2) |
| 10 | PGND | FET driver block ground |
| 11 | OUT1 | FET driver block output (CH1) |
| 12 | PVcc1 | FET driver block power supply input (CH1) |
| 13 | DTC1 | Maximum duty/soft start setting (CH1) |
| 14 | SCP | Short circuit protection timer setting capacitor connection |
| 15 | FB1 | Error Amp output (CH1) |
| 16 | INV1 | Error Amp inverting input (CH1) |
| 17 | VREF | Reference voltage (2.5V±1%) output |
| 18 | Vcc | Power supply input |
| 19 | STB | ON/OFF control |
| 20 | GND | Ground |
| - | FIN on reverse | Make FIN on the reverse open or ground to GND (pin 20) (However, open FIN on the reverse will degrade radiation performance.) |

● Description of operations

1) Reference voltage block

The reference voltage block generates a constant voltage with temperature compensated through inputting the power supplied from the Vcc pin. The output voltage is 2.5 V, with a $\pm 1\%$ accuracy. To cancel noises, insert a capacitor with a low ESR (several tens of m Ω) between the VREF and GND pins. It is recommended to use a ceramic capacitor of 1 μF for this purpose.

2) Triangular wave oscillator block

By connecting the resistor and capacitor of frequency settings to the RT and CT pins (only to RT pin on the BD9850FVM), a triangular wave will be generated and then input to the PWM comparators of Channels 1 and 2.

3) Error Amp block

The Error Amp block detects the output voltage of the INV pin, amplifies an error with the set output voltage, and then outputs the error from the FB pin. The comparison voltage is 1 V, with a $\pm 2\%$ accuracy. (The Channel 2 of the BD9851EFV uses the NON pin input voltage as a reference.)

Inserting a resistor and capacitor between the INV and FB pins will conduct phase compensation.

4) PWM comparator block

The PWM comparator block converts the output voltage (FB voltage) into a PWM waveform and outputs it to the FET driver.

<Dead time control> (Only available on the BD9851EFV)

Inputting a voltage, divided by resistance of the VREF pin in the DTC pin, will allow maximum ON duty setting.

<Soft start (BD9850FVM)>

Inserting a capacitor between the CTL/SS and GND pins will allow the soft start function to control the rising output voltage.

<Soft start (BD9851EFV)>

Inserting a capacitor between the DTC and GND pins will allow the soft start function to control the rising output voltage.

Furthermore, the overshoot of output voltage at startup can be derated. Adding a Schottky diode between the FB and DTC pins will make it possible to suppress the overshoot rate (only available with step-down application).

5) FET driver block

This block is a push-pull type driver enabling direct drive of external MOS FET.

<Setting of step-down/step-up switching (Only available for Channel 1 of BD9851EFV)>

For the Channel 1, SEL1 pin setting will determine the application function.

Set the SEL1 pin to step-down (P-ch drive) mode for short-circuiting Vcc or to step-up (N-ch drive) mode for short-circuiting GND.

Furthermore, be sure to short-circuit the SEL1 pin to Vcc or GND pin.

6) Standby function

(BD9850FVM)

The CTL/SS pin allows for output ON/OFF control. Set the CTL/SS pin voltage to "H" to activate the output ON control.

(BD9851EFV)

The STB pin allows for output ON/OFF control. Set the STB pin voltage to "H" to activate the output ON control.

The standby mode circuit current should be set to less than 5 μA .

7) Short circuit protection circuit (SCP) (Only available on BD9851EFV)

The SCP is a timer-latch type short circuit protection circuit.

If the output voltage of either channel drops below the set voltage, the Error Amp will be activated to increase the FB voltage and initiate charging the capacitor connected to the SCP pin with a 2 μA current. When the SCP pin voltage exceeds 1.5 V, the latch circuit will be activated to fix the output of both channels at OFF and, at the same time, the DTC pin at "L" level.

In order to rest the latch circuit, set the STB pin to "L" level once, and then to "H" level. Or, turn ON the power supply again.

Furthermore, if the short circuit protection circuit is not used, short-circuit the SCP pin to the GND pin.

8) Under Voltage Lock Out (UVLO) circuit

The UVLO is a protection circuit to prevent the IC from malfunctioning when the power supply turns ON or if an instantaneous power interruption occurs.

When the Vcc voltage falls below 3.8 V (or 3.7 V on the BD9851EFV), the output of both channels will be fixed at "OFF" and, at the same time, the DTC pin at "L" level. Hysteresis width of 0.1 V (or 0.11 V on the BD9851EFV) is provided for the detection voltage and release voltage of the UVLO in order to prevent malfunctions of the IC which may result from variations in the input voltage due to threshold online.

Furthermore, if the latch circuit is activated through the short circuit protection circuit, the circuit will be reset by this UVLO.

9) Thermal shutdown circuit (TSD)

The TSD is a protection circuit to prevent the destruction of the IC due to abnormal heat generation.

If the TSD detects an abnormal heat generation (175°C) on the chip, the output of both channels will be fixed at "OFF" and, at the same time, the DTC pin at "L" level. Hysteresis width (15°C) is provided for the superheat detection and release temperatures in order to prevent malfunctions of the IC which may result from variations in the input voltage due to threshold online.

Furthermore, if the latch circuit is activated through the short circuit protection circuit, the circuit will be reset by this TSD.

● Timing chart

- In startup/normal operation (BD9850FVM)

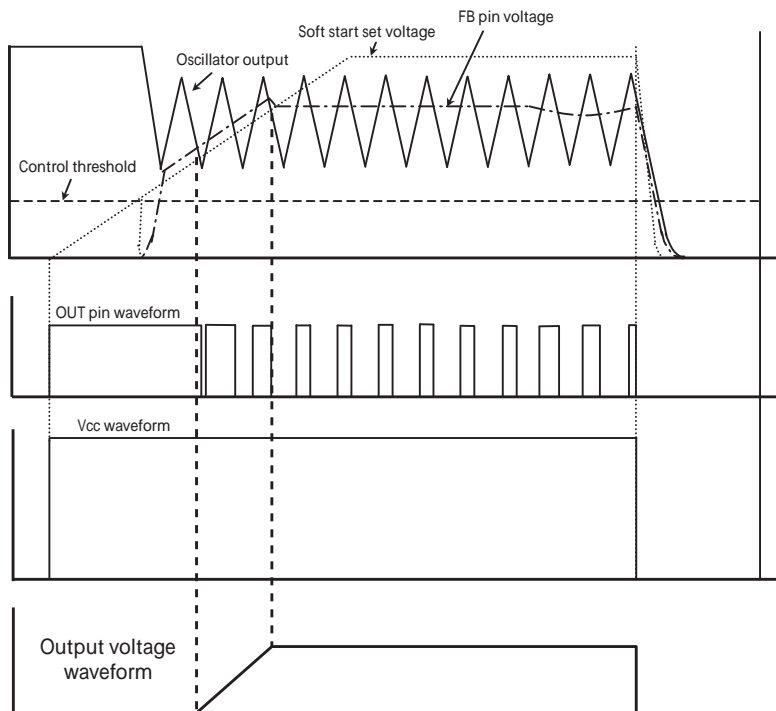

Fig.15 BD9850FVM Timing chart

(BD9851EFV)

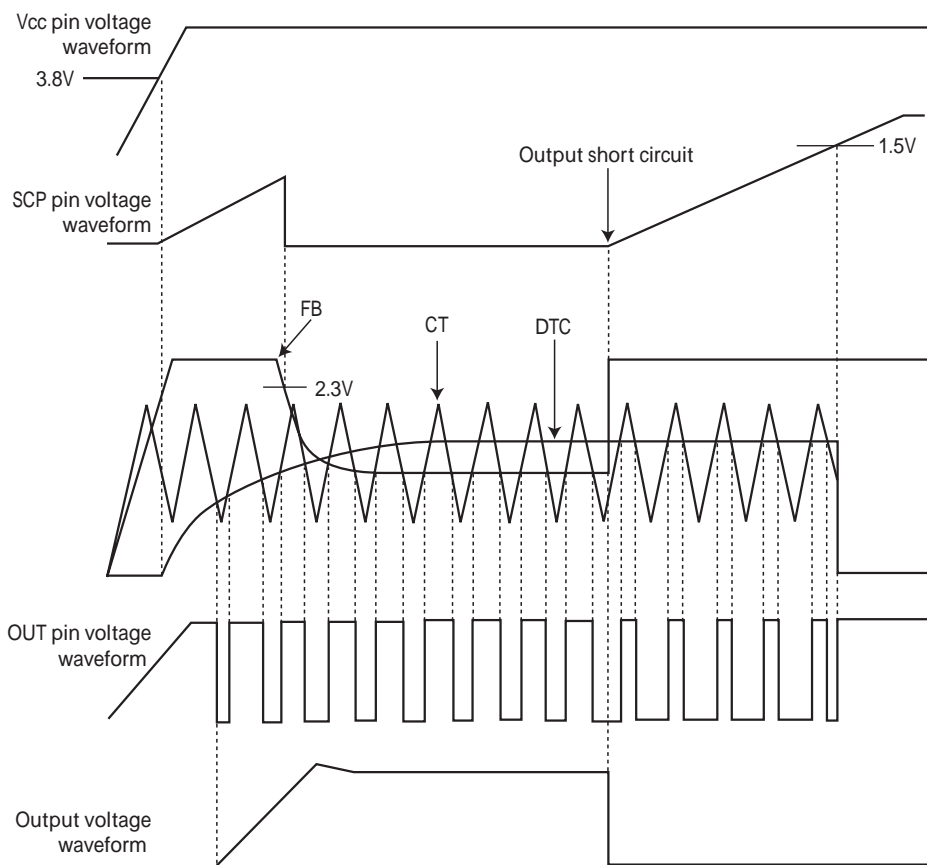
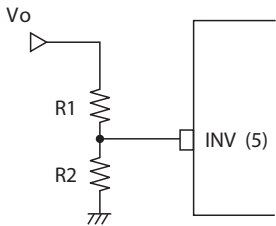

Fig.16 BD9851EFV Timing chart

● **Description of external components**

- Setting of output voltage (BD9850FVM)

Setting of output voltage for the step-down application can be calculated by the formula below :

| Setting procedure | Application |
|--|--|
| $V_o = V_{thea} \times (R_1 + R_2) / R_2 \text{ [V]}$ (V _{thea} : Error Amp threshold voltage Typ. 1.0 [V]) |  |

● **Setting of output voltage (BD9851EFV)**

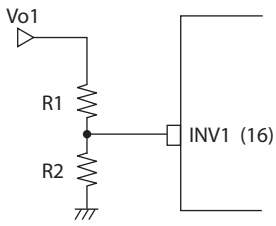
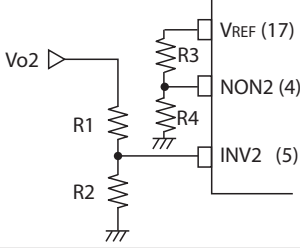
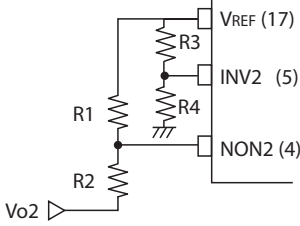
| Setting procedure | Application |
|--|--|
| <ul style="list-style-type: none"> • Step-down (CH1), Step-up (CH1) $V_{o1} = V_{thea} \times (R_1 + R_2) / R_2 \text{ [V]}$ (V _{thea} : Error Amp threshold voltage Typ. 1.0 [V]) |  |
| <ul style="list-style-type: none"> • Step-down (CH2) $V_{o2} = V_{NON2} \times (R_1 + R_2) / R_2 \text{ [V]}$ $V_{NON2} = 2.5 \times R_4 / (R_3 + R_4) \text{ [V]}$ However, set the NON2 pin voltage to 0.3 to 2.0 V. |  |
| <ul style="list-style-type: none"> • Inverting (CH2) $V_{o2} = 2.5 - \{(2.5 - V_{INV2}) \times (R_1 + R_2) / R_1\} \text{ [V]}$ $V_{INV2} = 2.5 \times R_4 / (R_3 + R_4) \text{ [V]}$ However, set the INV2 pin voltage to 0.3 to 2.0 V |  |

● **Setting of oscillation frequency (BD9850FVM)**

Connecting a resistor to the RT pin (pin 2) allows for the setting of oscillation frequency.

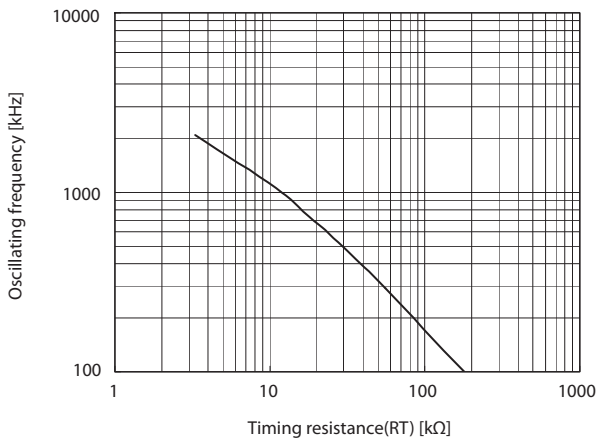

Fig.18 RT vs. Oscillation frequency

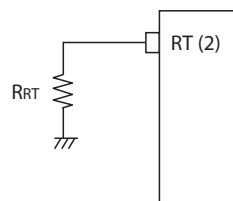

Fig.17 Setting procedure for BD9850FVM oscillation frequency

• Setting of oscillation frequency (BD9851EFV)

Connecting a resistor to the RT pin (pin 2) and a capacitor to the CT pin allows for the setting of oscillation frequency.

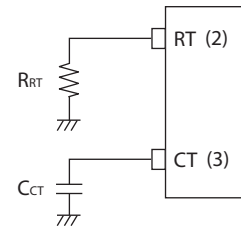

Fig. 19 Setting procedure for BD9851EFV oscillation frequency

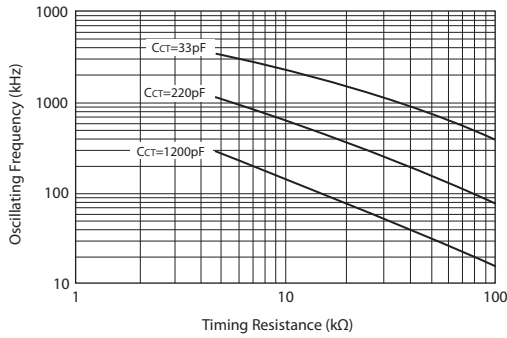

Fig. 20 RT vs. Oscillation frequency

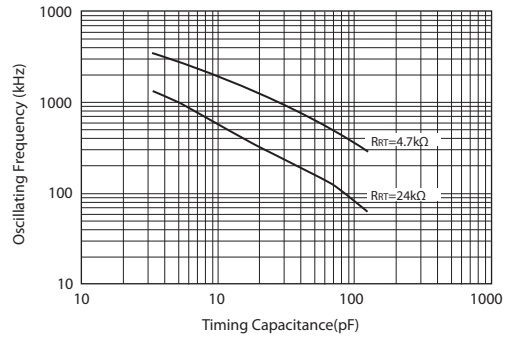

Fig. 20 CT vs. Oscillation frequency

• Setting of timer of short circuit protection circuit (BD9851EFV)

| Setting procedure | Application |
|--|-------------|
| $T_{SCP} = 7.45 \times 10^5 \times C_{SCP}$ <p>T_{SCP} : Time from output short circuit to latch stop [sec] C_{SCP} : Capacitance of capacitor between the SCP and GND pins [F]</p> | |

• Setting of maximum duty (BD9851EFV)

Setting procedure

$$DUTY(max.) = 100 \times (V_{DTC} - V_{th0}) / (V_{th100} - V_{th0})$$

$$V_{DTC} = 2.5 \times R2 / (R1 + R2)$$

DUTY(max.) : Maximum duty [%]
 V_{DTC} : DTC pin voltage [V]
 V_{th0} : 0% duty threshold voltage [V]
 V_{th100} : 100% duty threshold voltage [V]

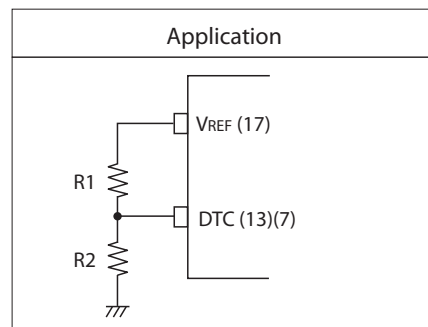

• Pin treatment of unused channels (BD9851EFV)

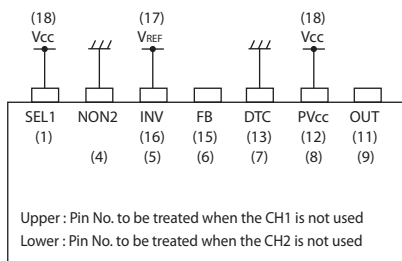

Fig. 22 Pin treatment procedure for unused channel on BD9851EFV

In order to use one channel, treat the pins of unused channel as shown above.

● Application circuit / Directions for pattern layout
(BD9850FVM)

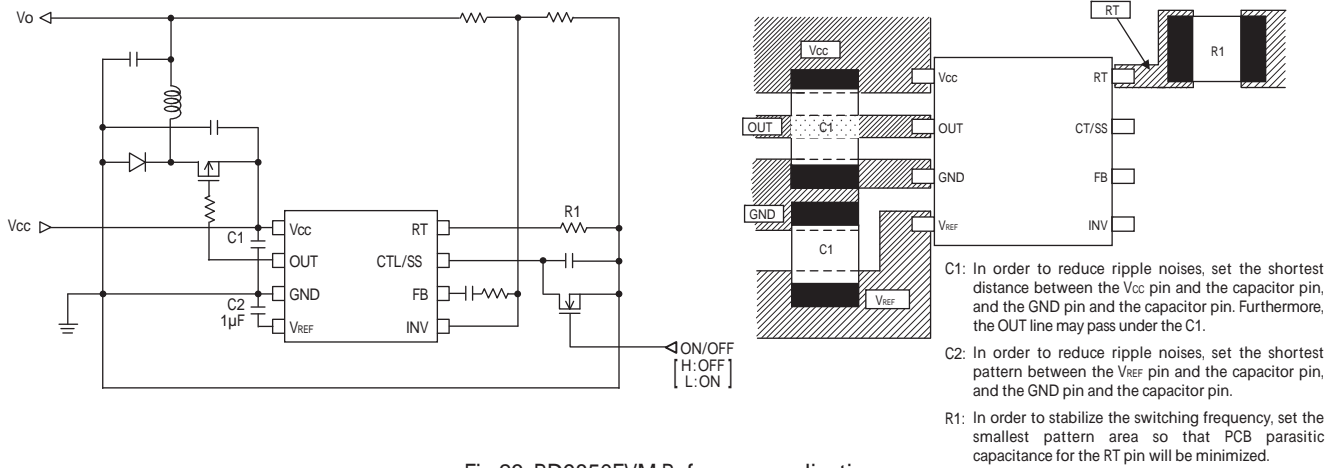

Fig.23 BD9850FVM Reference application

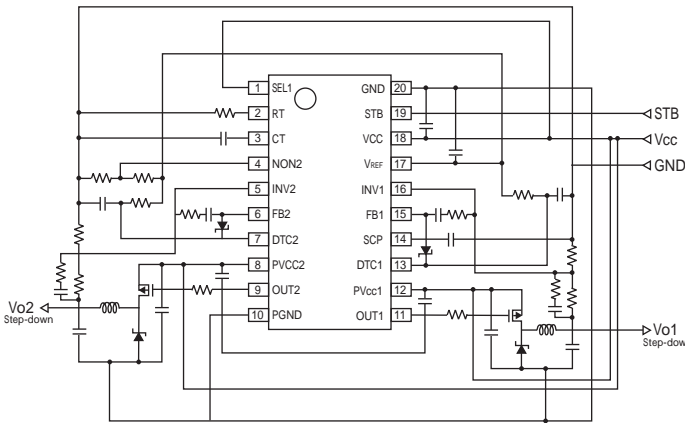

Fig.24 Step-down/Step-up application

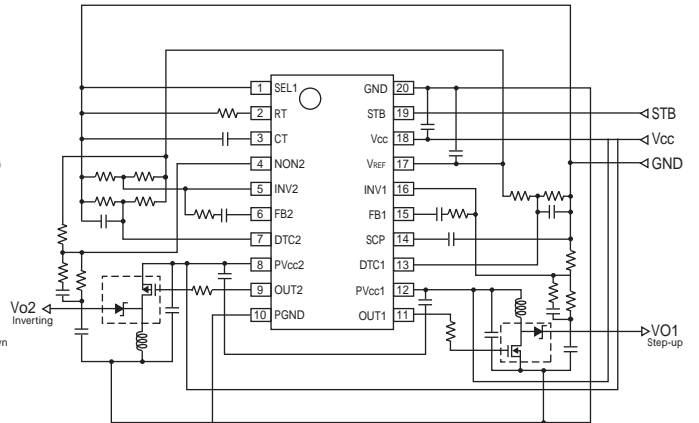

Fig.25 Step-up/Inverting application

● Equivalent circuit
(BD9850FVM)

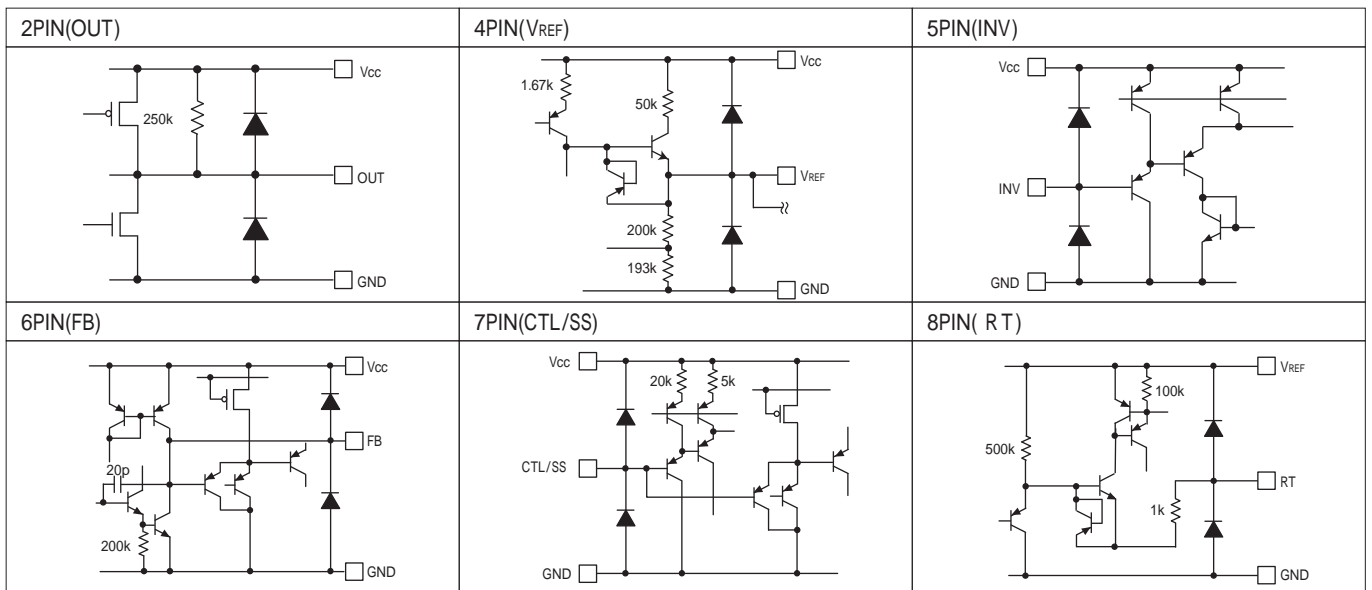

Fig.26 Equivalent circuit (BD9850FVM)

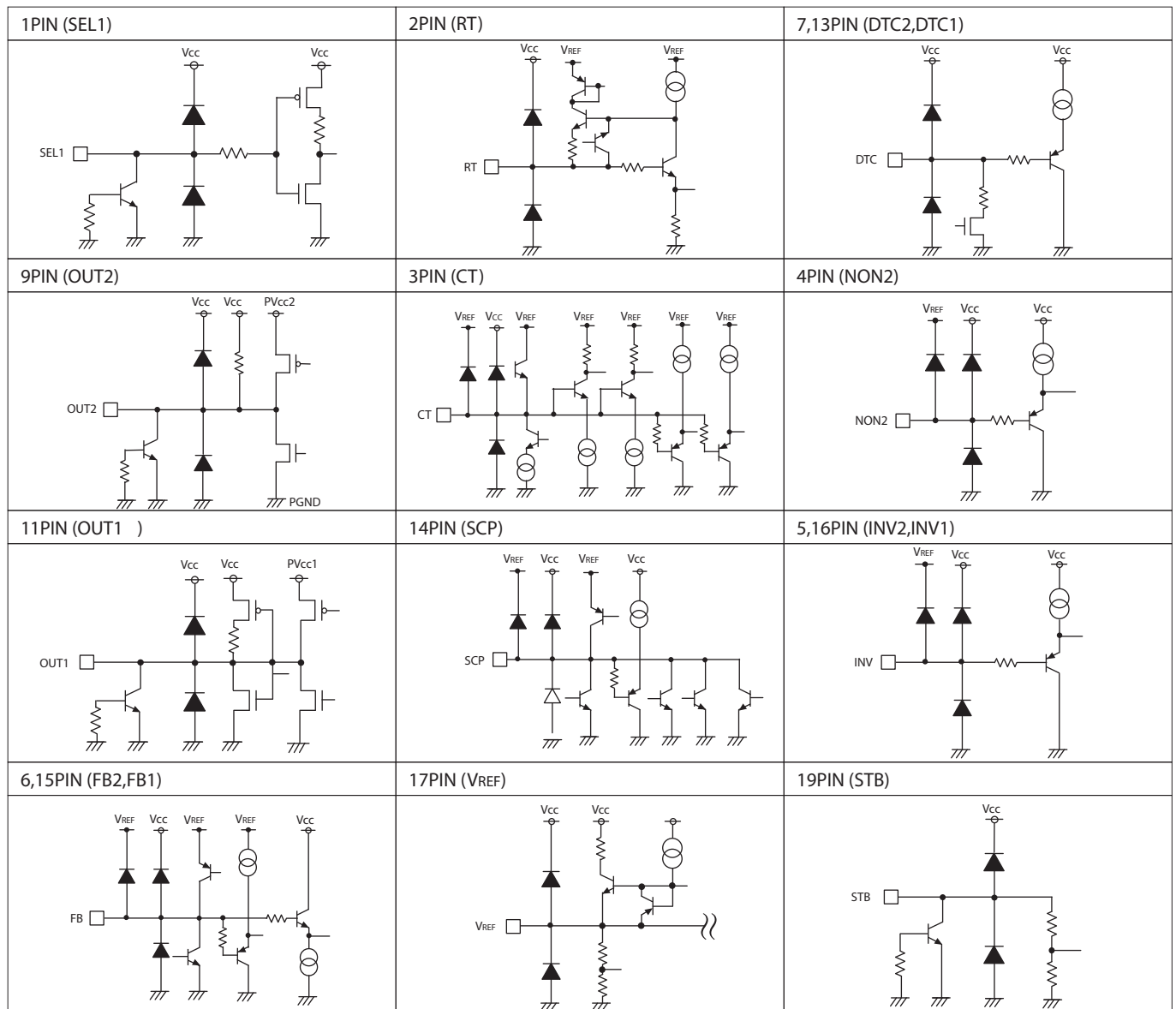

Fig.27 Equivalent circuit (BD9851EFV)

● Cautions on use

- 1) Absolute maximum ratings
An excess in the absolute maximum ratings, such as supply voltage, temperature range of operating conditions, etc., can break down the devices, thus making impossible to identify breaking mode, such as a short circuit or an open circuit. If any over rated values will expect to exceed the absolute maximum ratings, consider adding circuit protection devices, such as fuses.
- 2) GND potential
Ground-GND potential should maintain at the minimum ground voltage level. Furthermore, no terminals should be lower than the GND potential voltage including an electric transients.
- 3) Thermal design
Use a thermal design that allows for a sufficient margin in light of the power dissipation (Pd) in actual operating conditions.
- 4) Inter-pin shorts and mounting errors
Use caution when positioning the IC for mounting on printed circuit boards. The IC may be damaged if there is any connection error or if positive and ground power supply terminals are reversed. The IC may also be damaged if pins are shorted together or are shorted to other circuit's power lines.
- 5) Operation in strong electromagnetic field
Use caution when using the IC in the presence of a strong electromagnetic field as doing so may cause the IC to malfunction.
- 6) Thermal shutdown circuit (TSD circuit)
The IC incorporates a built-in thermal shutdown circuit (TSD circuit). The thermal shutdown circuit (TSD circuit) is designed only to shut the IC off to prevent runaway thermal operation. It is not designed to protect the IC or guarantee its operation. Do not continue to use the IC after operating this circuit or use the IC in an environment where the operation of this circuit is assumed.
- 7) Testing on application boards
When testing the IC on an application board, connecting a capacitor to a pin with low impedance subjects the IC to stress. Always discharge capacitors after each process or step. Always turn the IC's power supply off before connecting it to, or removing it from a jig or fixture, during the inspection process. Ground the IC during assembly steps as an antistatic measure. Use similar precaution when transporting and storing the IC.

8) IC pin input

This monolithic IC contains P+ isolation and P substrate layers between adjacent elements to keep them isolated. Pin junctions are formed at the intersection of these P layers with the N layers of other elements, creating a parasitic diode or transistor. For example, the relation between each potential is as follows:

When $GND > Pin A$ and $GND > Pin B$, the Pin junction operates as a parasitic diode.

When $Pin B > GND > Pin A$, the PnN junction operates as a parasitic transistor.

Parasitic diodes can occur inevitably in the structure of the IC. The operation of parasitic diodes can result in mutual interference among circuits, operational faults, or physical damage. Accordingly, methods by which parasitic diodes operate, such as applying a voltage that is lower than the GND (P substrate) voltage to an input pin, should not be used.

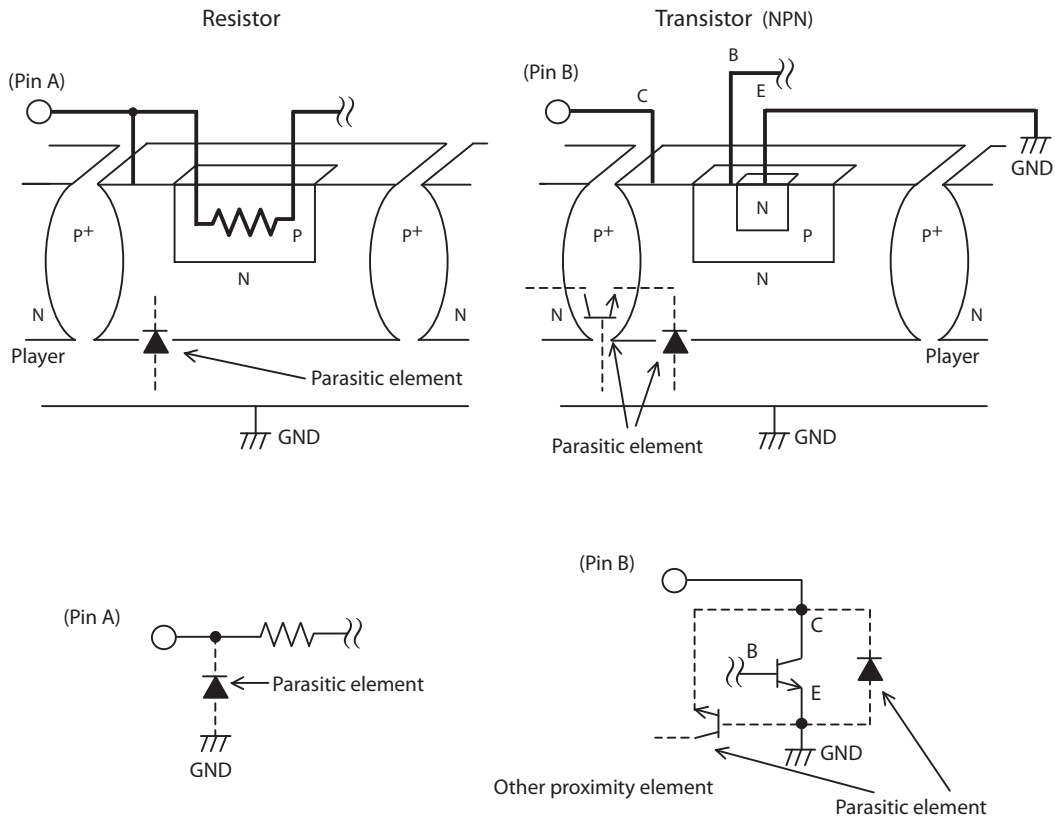

Fig. 28 Typical simple construction of monolithic IC

9) Common impedance

The power supply and ground lines must be as short and thick as possible to reduce line impedance. Fluctuating voltage on the power ground line may damage the device.

10) On the application shown below, V_{cc} is short-circuited to the Ground with external diode charged, internal circuits may be damaged. recommended to insert a backflow prevention diode in series with the V_{cc} or a bypass diode between each pin and V_{cc} .

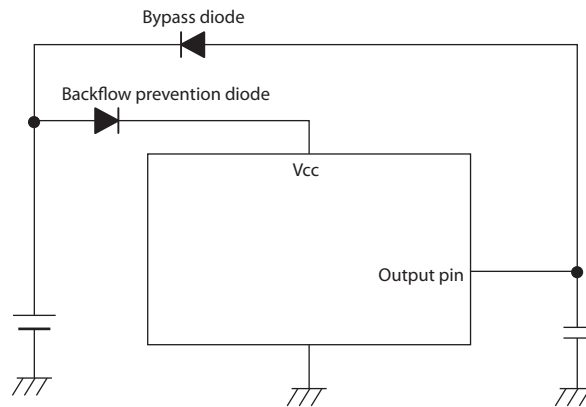

Fig. 29

- 11) Although ROHM is confident that the example application circuit reflects the best possible recommendations, be sure to verify circuit characteristics for your particular application. Modification of constants for other externally connected circuits may cause variations in both static and transient characteristics for external components as well as this Rohm IC. Allow for sufficient margins when determining circuit constants.

Oscillation frequency setting resistor

- 12) For the oscillation frequency setting resistor to be inserted between the RT pin and the GND pin, mount this resistor close to the RT pin and provide the shortest pattern routing.

● Thermal derating characteristics

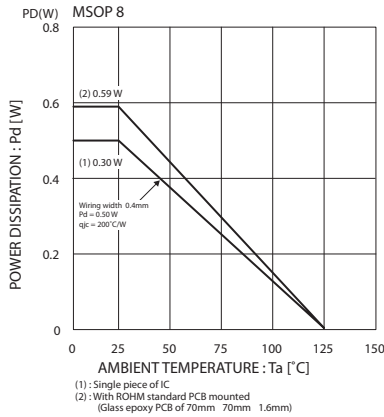

Fig.30

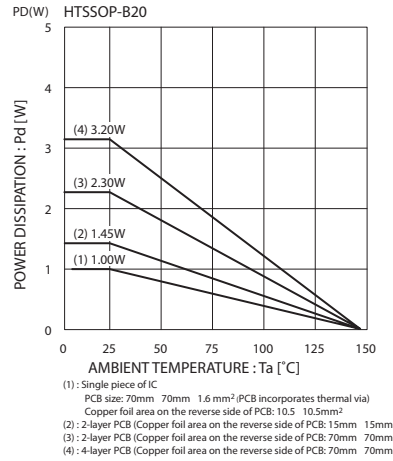
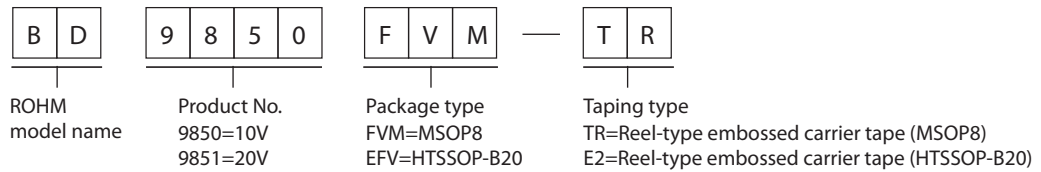
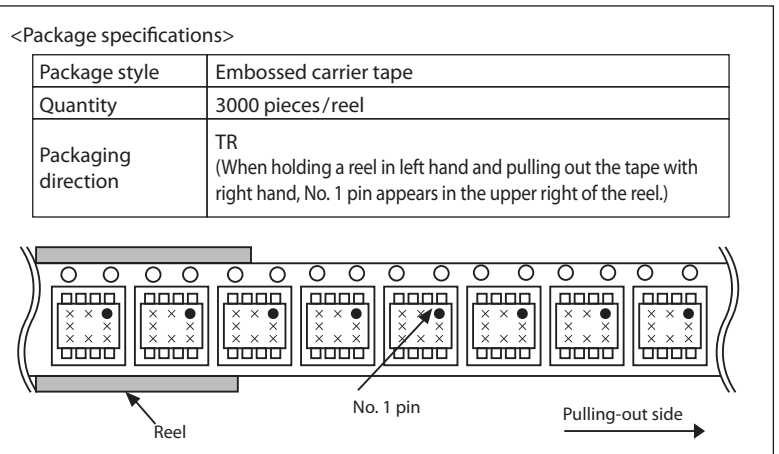
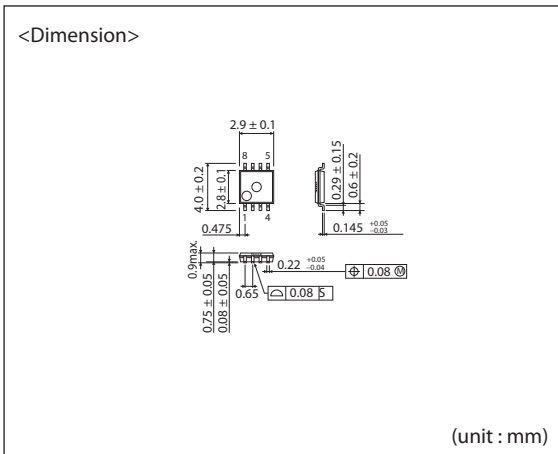

Fig.31

● Selection of order type



MSOP8



HTSSOP-B20

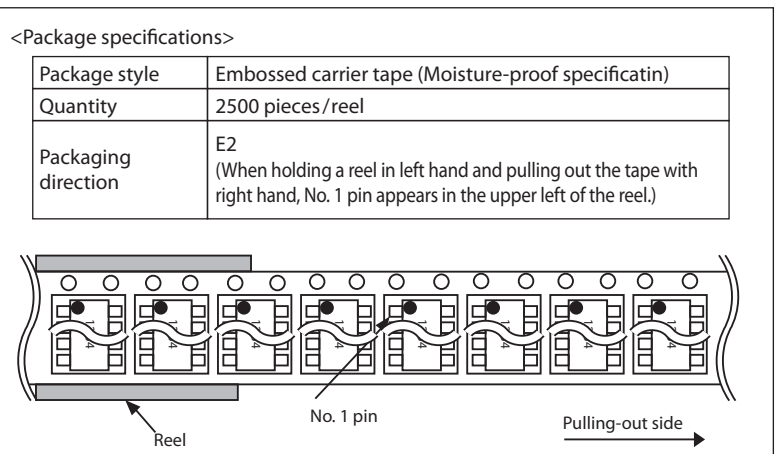
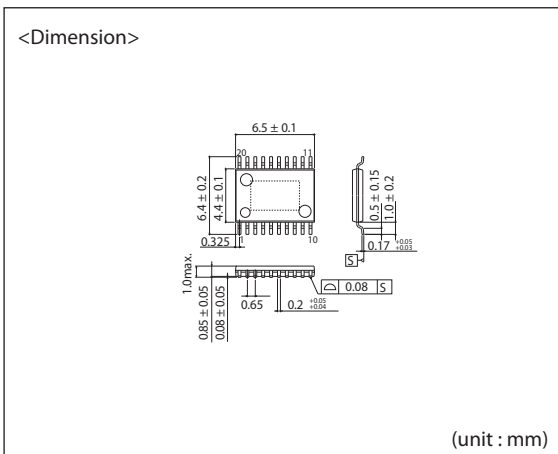

- The contents described herein are correct as of September, 2008
- The contents described herein are subject to change without notice. For updates of the latest information, please contact and confirm with ROHM CO.,LTD.
- Any part of this application note must not be duplicated or copied without our permission.
- Application circuit diagrams and circuit constants contained herein are shown as examples of standard use and operation. Please pay careful attention to the peripheral conditions when designing circuits and deciding upon circuit constants in the set.
- Any data, including, but not limited to application circuit diagrams and information, described herein are intended only as illustrations of such devices and not as the specifications for such devices. ROHM CO.,LTD. disclaims any warranty that any use of such devices shall be free from infringement of any third party's intellectual property rights or other proprietary rights, and further, assumes no liability of whatsoever nature in the event of any such infringement, or arising from or connected with or related to the use of such devices.
- Upon the sale of any such devices, other than for buyer's right to use such devices itself, resell or otherwise dispose of the same, implied right or license to practice or commercially exploit any intellectual property rights or other proprietary rights owned or controlled by ROHM CO., LTD. is granted to any such buyer.
- The products described herein utilize silicon as the main material.
- The products described herein are not designed to be X ray proof.

The products listed in this catalog are designed to be used with ordinary electronic equipment or devices (such as audio visual equipment, office-automation equipment, communications devices, electrical appliances and electronic toys). Should you intend to use these products with equipment or devices which require an extremely high level of reliability and the malfunction of which would directly endanger human life (such as medical instruments, transportation equipment, aerospace machinery, nuclear-reactor controllers, fuel controllers and other safety devices), please be sure to consult with our sales representative in advance.

Contact us for further information about the products.

| | | | | | |
|-----------------------|------------------------|------------------------|---------------------|------------------------|------------------------|
| San Diego | TEL: +1-858-625-3630 | FAX: +1-858-625-3670 | Tianjin | TEL: +86-22-23029181 | FAX: +86-22-23029183 |
| Atlanta | TEL: +1-770-754-5972 | FAX: +1-770-754-0691 | Shanghai | TEL: +86-21-6279-2727 | FAX: +86-21-6247-2066 |
| Boston | TEL: +1-978-371-0382 | FAX: +1-928-438-7164 | Hangzhou | TEL: +86-571-87658072 | FAX: +86-571-87658071 |
| Chicago | TEL: +1-847-368-1006 | FAX: +1-847-368-1008 | Nanjing | TEL: +86-25-8689-0015 | FAX: +86-25-8689-0393 |
| Dallas | TEL: +1-469-287-5366 | FAX: +1-469-362-7973 | Ningbo | TEL: +86-574-87654201 | FAX: +86-574-87654208 |
| Denver | TEL: +1-303-708-0908 | FAX: +1-303-708-0858 | Qingdao | TEL: +86-532-5779-312 | FAX: +86-532-5779-653 |
| Detroit | TEL: +1-248-348-9920 | FAX: +1-248-348-9942 | Suzhou | TEL: +86-512-6807-1300 | FAX: +86-512-6807-2300 |
| Nashville | TEL: +1-615-620-6700 | FAX: +1-615-620-6702 | Wuxi | TEL: +86-510-82702693 | FAX: +86-510-82702992 |
| Mexico | TEL: +52-33-3123-2001 | FAX: +52-33-3123-2002 | Shenzhen | TEL: +86-755-8307-3008 | FAX: +86-755-8307-3003 |
| Düsseldorf | TEL: +49-2154-9210 | FAX: +49-2154-921400 | Dongguan | TEL: +86-769-8393-3320 | FAX: +86-769-8398-4140 |
| Munich | TEL: +49-8999-216168 | FAX: +49-8999-216176 | Fuzhou | TEL: +86-591-8801-8698 | FAX: +86-591-8801-8690 |
| Stuttgart | TEL: +49-711-7272-370 | FAX: +49-711-7272-3720 | Guangzhou | TEL: +86-20-3878-8100 | FAX: +86-20-3825-5965 |
| France | TEL: +33-1-5697-3060 | FAX: +33-1-5697-3080 | Huizhou | TEL: +86-752-205-1054 | FAX: +86-752-205-1059 |
| United Kingdom | TEL: +44-1-908-306700 | FAX: +44-1-908-235788 | Xiamen | TEL: +86-592-238-5705 | FAX: +86-592-239-8380 |
| Denmark | TEL: +45-3694-4739 | FAX: +45-3694-4789 | Zhuhai | TEL: +86-756-3232-480 | FAX: +86-756-3232-460 |
| Espoo | TEL: +358-9725-54491 | FAX: +358-9-7255-4499 | Hong Kong | TEL: +852-2-740-6262 | FAX: +852-2-375-8971 |
| Salo | TEL: +358-2-7332234 | FAX: +358-2-7332237 | Taipei | TEL: +886-2-2500-6956 | FAX: +886-2-2503-2869 |
| Oulu | TEL: +358-9-5372930 | FAX: +358-8-5372931 | Kaohsiung | TEL: +886-7-237-0881 | FAX: +886-7-238-7332 |
| Barcelona | TEL: +34-9375-24320 | FAX: +34-9375-24410 | Singapore | TEL: +65-6332-2322 | FAX: +65-6332-5662 |
| Hungary | TEL: +36-1-4719338 | FAX: +36-1-4719339 | Philippines | TEL: +63-2-807-6872 | FAX: +63-2-809-1422 |
| Poland | TEL: +48-22-5757213 | FAX: +48-22-5757001 | Thailand | TEL: +66-2-254-4890 | FAX: +66-2-256-6334 |
| Russia | TEL: +7-495-739-41-74 | FAX: +7-495-739-41-74 | Kuala Lumpur | TEL: +60-3-7958-8355 | FAX: +60-3-7958-8377 |
| Seoul | TEL: +82-2-8182-700 | FAX: +82-2-8182-715 | Penang | TEL: +60-4-2286453 | FAX: +60-4-2286452 |
| Masan | TEL: +82-55-240-6234 | FAX: +82-55-240-6236 | Kyoto | TEL: +81-75-365-1218 | FAX: +81-75-365-1228 |
| Dalian | TEL: +86-411-8230-8549 | FAX: +86-411-8230-8537 | Yokohama | TEL: +81-45-476-2290 | FAX: +81-45-476-2295 |
| Beijing | TEL: +86-10-8525-2483 | FAX: +86-10-8525-2489 | | | |

Excellence in Electronics

ROHM

ROHM CO., LTD.

21 Saiin Mizosaki-cho, Ukyo-ku, Kyoto
615-8585, Japan
TEL: +81-75-311-2121 FAX: +81-75-315-0172
URL <http://www.rohm.com>

Published by
KTC LSI Development Headquarters
LSI Business Promotion Group

Notice

Precaution on using ROHM Products

- Our Products are designed and manufactured for application in ordinary electronic equipments (such as AV equipment, OA equipment, telecommunication equipment, home electronic appliances, amusement equipment, etc.). If you intend to use our Products in devices requiring extremely high reliability (such as medical equipment ^(Note 1), transport equipment, traffic equipment, aircraft/spacecraft, nuclear power controllers, fuel controllers, car equipment including car accessories, safety devices, etc.) and whose malfunction or failure may cause loss of human life, bodily injury or serious damage to property ("Specific Applications"), please consult with the ROHM sales representative in advance. Unless otherwise agreed in writing by ROHM in advance, ROHM shall not be in any way responsible or liable for any damages, expenses or losses incurred by you or third parties arising from the use of any ROHM's Products for Specific Applications.

(Note1) Medical Equipment Classification of the Specific Applications

| JAPAN | USA | EU | CHINA |
|-----------|-----------|------------|-----------|
| CLASS III | CLASS III | CLASS II b | CLASS III |
| CLASS IV | | CLASS III | |

- ROHM designs and manufactures its Products subject to strict quality control system. However, semiconductor products can fail or malfunction at a certain rate. Please be sure to implement, at your own responsibilities, adequate safety measures including but not limited to fail-safe design against the physical injury, damage to any property, which a failure or malfunction of our Products may cause. The following are examples of safety measures:
 - Installation of protection circuits or other protective devices to improve system safety
 - Installation of redundant circuits to reduce the impact of single or multiple circuit failure
- Our Products are designed and manufactured for use under standard conditions and not under any special or extraordinary environments or conditions, as exemplified below. Accordingly, ROHM shall not be in any way responsible or liable for any damages, expenses or losses arising from the use of any ROHM's Products under any special or extraordinary environments or conditions. If you intend to use our Products under any special or extraordinary environments or conditions (as exemplified below), your independent verification and confirmation of product performance, reliability, etc. prior to use, must be necessary:
 - Use of our Products in any types of liquid, including water, oils, chemicals, and organic solvents
 - Use of our Products outdoors or in places where the Products are exposed to direct sunlight or dust
 - Use of our Products in places where the Products are exposed to sea wind or corrosive gases, including Cl₂, H₂S, NH₃, SO₂, and NO₂
 - Use of our Products in places where the Products are exposed to static electricity or electromagnetic waves
 - Use of our Products in proximity to heat-producing components, plastic cords, or other flammable items
 - Sealing or coating our Products with resin or other coating materials
 - Use of our Products without cleaning residue of flux (even if you use no-clean type fluxes, cleaning residue of flux is recommended); or Washing our Products by using water or water-soluble cleaning agents for cleaning residue after soldering
 - Use of the Products in places subject to dew condensation
- The Products are not subject to radiation-proof design.
- Please verify and confirm characteristics of the final or mounted products in using the Products.
- In particular, if a transient load (a large amount of load applied in a short period of time, such as pulse. is applied, confirmation of performance characteristics after on-board mounting is strongly recommended. Avoid applying power exceeding normal rated power; exceeding the power rating under steady-state loading condition may negatively affect product performance and reliability.
- De-rate Power Dissipation (Pd) depending on Ambient temperature (Ta). When used in sealed area, confirm the actual ambient temperature.
- Confirm that operation temperature is within the specified range described in the product specification.
- ROHM shall not be in any way responsible or liable for failure induced under deviant condition from what is defined in this document.

Precaution for Mounting / Circuit board design

- When a highly active halogenous (chlorine, bromine, etc.) flux is used, the residue of flux may negatively affect product performance and reliability.
- In principle, the reflow soldering method must be used; if flow soldering method is preferred, please consult with the ROHM representative in advance.

For details, please refer to ROHM Mounting specification

Precautions Regarding Application Examples and External Circuits

1. If change is made to the constant of an external circuit, please allow a sufficient margin considering variations of the characteristics of the Products and external components, including transient characteristics, as well as static characteristics.
2. You agree that application notes, reference designs, and associated data and information contained in this document are presented only as guidance for Products use. Therefore, in case you use such information, you are solely responsible for it and you must exercise your own independent verification and judgment in the use of such information contained in this document. ROHM shall not be in any way responsible or liable for any damages, expenses or losses incurred by you or third parties arising from the use of such information.

Precaution for Electrostatic

This Product is electrostatic sensitive product, which may be damaged due to electrostatic discharge. Please take proper caution in your manufacturing process and storage so that voltage exceeding the Products maximum rating will not be applied to Products. Please take special care under dry condition (e.g. Grounding of human body / equipment / solder iron, isolation from charged objects, setting of ionizer, friction prevention and temperature / humidity control).

Precaution for Storage / Transportation

1. Product performance and soldered connections may deteriorate if the Products are stored in the places where:
 - [a] the Products are exposed to sea winds or corrosive gases, including Cl₂, H₂S, NH₃, SO₂, and NO₂
 - [b] the temperature or humidity exceeds those recommended by ROHM
 - [c] the Products are exposed to direct sunshine or condensation
 - [d] the Products are exposed to high Electrostatic
2. Even under ROHM recommended storage condition, solderability of products out of recommended storage time period may be degraded. It is strongly recommended to confirm solderability before using Products of which storage time is exceeding the recommended storage time period.
3. Store / transport cartons in the correct direction, which is indicated on a carton with a symbol. Otherwise bent leads may occur due to excessive stress applied when dropping of a carton.
4. Use Products within the specified time after opening a humidity barrier bag. Baking is required before using Products of which storage time is exceeding the recommended storage time period.

Precaution for Product Label

QR code printed on ROHM Products label is for ROHM's internal use only.

Precaution for Disposition

When disposing Products please dispose them properly using an authorized industry waste company.

Precaution for Foreign Exchange and Foreign Trade act

Since our Products might fall under controlled goods prescribed by the applicable foreign exchange and foreign trade act, please consult with ROHM representative in case of export.

Precaution Regarding Intellectual Property Rights

1. All information and data including but not limited to application example contained in this document is for reference only. ROHM does not warrant that foregoing information or data will not infringe any intellectual property rights or any other rights of any third party regarding such information or data. ROHM shall not be in any way responsible or liable for infringement of any intellectual property rights or other damages arising from use of such information or data.:
2. No license, expressly or implied, is granted hereby under any intellectual property rights or other rights of ROHM or any third parties with respect to the information contained in this document.

Other Precaution



1. This document may not be reprinted or reproduced, in whole or in part, without prior written consent of ROHM.
2. The Products may not be disassembled, converted, modified, reproduced or otherwise changed without prior written consent of ROHM.
3. In no event shall you use in any way whatsoever the Products and the related technical information contained in the Products or this document for any military purposes, including but not limited to, the development of mass-destruction weapons.
4. The proper names of companies or products described in this document are trademarks or registered trademarks of ROHM, its affiliated companies or third parties.

General Precaution

1. Before you use our Products, you are requested to carefully read this document and fully understand its contents. ROHM shall not be in any way responsible or liable for failure, malfunction or accident arising from the use of any ROHM's Products against warning, caution or note contained in this document.
2. All information contained in this document is current as of the issuing date and subject to change without any prior notice. Before purchasing or using ROHM's Products, please confirm the latest information with a ROHM sales representative.
3. The information contained in this document is provided on an "as is" basis and ROHM does not warrant that all information contained in this document is accurate and/or error-free. ROHM shall not be in any way responsible or liable for any damages, expenses or losses incurred by you or third parties resulting from inaccuracy or errors of or concerning such information.

Looking for pricing, stock, or lifecycle information?

Click below to explore more details on WIN SOURCE:

-  [View BD9851EFV-E2 on WIN SOURCE](#)
-  [Rohm Semiconductor](#) Information

Optimize Your Supply Chain with WIN SOURCE Solutions

-  Global Sourcing Solution
-  Obsolete Management
-  Cost Control Management
-  Shortage Management
-  Alternative Solution
-  Excess Inventory Management