



**THE DATASHEET OF  
MM912F634BV1AE**



# Integrated S12 Based Relay Driver with LIN

The MM912F634 is an integrated single package solution integrating an HCS12 microcontroller with a SMARTMOS analog control IC. The Die to Die Interface (D2D) controlled analog die combines system base chip and application specific functions, including a LIN transceiver.

## Features

- 16-Bit S12 CPU, 32 kByte FLASH, 2.0 kByte RAM
- Background debug (BDM) & debug module (DBG)
- Die to die bus interface for transparent memory mapping
- On-chip oscillator & two independent watchdogs
- LIN 2.1 physical layer interface with integrated SCI
- Six digital MCU GPIOs shared with SPI (PA5...0)
- 10-Bit, 15 channel - analog to digital converter (ADC)
- 16-Bit, four channel - timer module (TIM16B4C)
- 8-Bit, two channel - pulse width modulation module (PWM)
- Six high-voltage / wake-up inputs (L5.0)
- Three low-voltage GPIOs (PB2.0)

## MM912F634



48-PIN LQFP 98ASH00962A 7.0 mm x 7.0 mm	48-PIN LQFP-EP 98ASA00173D 7.0 mm x 7.0 mm
AP SUFFIX: Non-exposed Pad	AE SUFFIX: Exposed Pad

- Low-power modes with cyclic sense & forced wake-up
- Current sense module with selectable gain
- Reverse battery protected voltage sense module
- Two protected low-side outputs to drive inductive loads
- Two protected high-side outputs
- Chip temperature sensor
- Hall sensor supply
- Integrated voltage regulator(s)

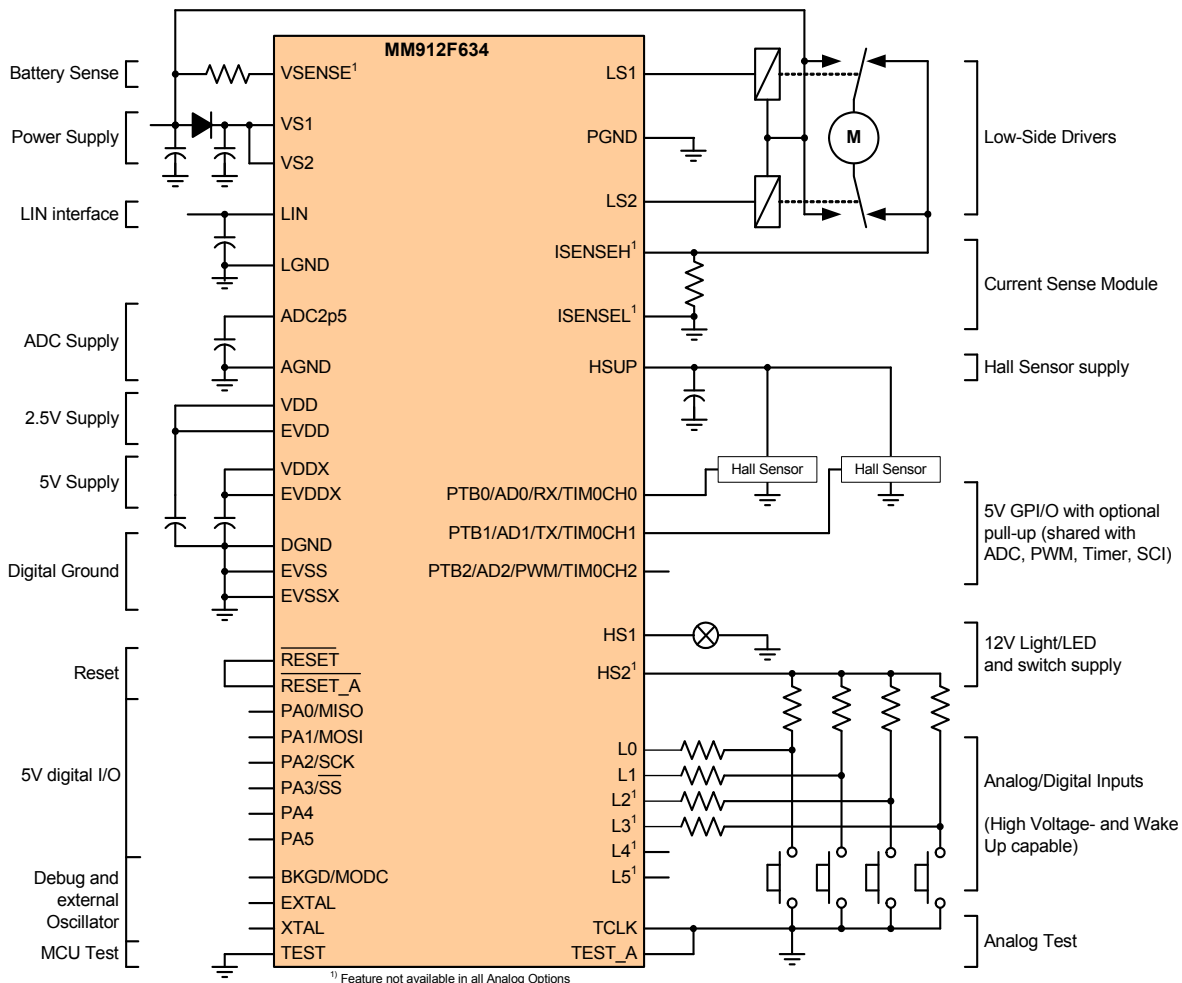

Figure 1. Simplified Application Diagram

# 1 Ordering Information

**Table 1. Ordering Information**

Device <sup>(2)</sup>	Temperature Range (T <sub>A</sub> )	Package	Max. Bus Frequency (MHz) (f <sub>BUSMAX</sub> )	Flash (kB)	RAM (kB)	Analog Option <sup>(1)</sup>
MM912F634DV1AE	-40 to 105 °C	98ASA00173D, 48-PIN LQFP-EP	20	32	2	1
MM912F634DV2AE						2
MM912F634DV2AP		98ASH00962A, 48-PIN LQFP	16	32		2

Note:

1. See [Table 2](#).
2. For Tape and Reel orders add R2 to the part suffix

**Table 2. Analog Options<sup>(3)</sup>**

Feature	Option 1	Option 2
Current Sense Module	YES	NO
Wake-up Inputs (Lx)	L0...L5	L0...L3

Note:

3. This table only highlights the analog die differences between the derivatives. See [Section 4.2.3, "Analog Die Options"](#) for detailed information.

The device part number follows the standard scheme below:

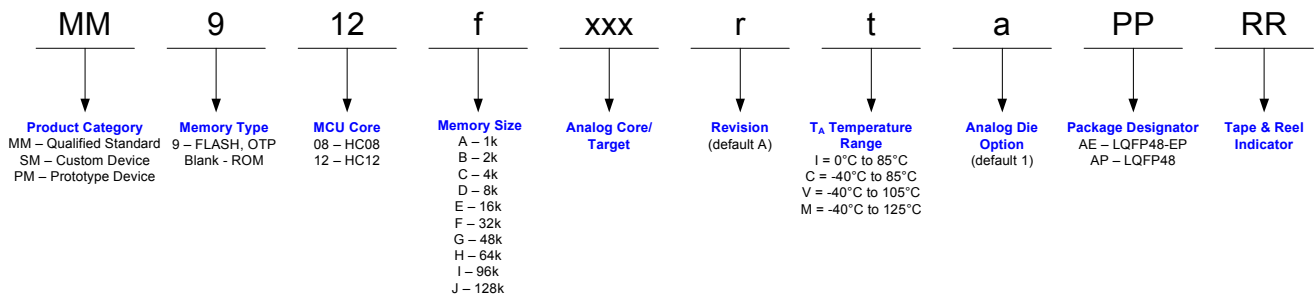

**Figure 2. Part Number Scheme**

# Table of Contents

1	Ordering Information .....	2
2	Pin Assignment .....	5
2.1	MM912F634 Pin Description .....	5
2.2	MCU Die Signal Properties .....	8
3	Electrical Characteristics .....	10
3.1	General .....	10
3.2	Absolute Maximum Ratings .....	10
3.3	Operating Conditions .....	11
3.4	Supply Currents .....	12
3.5	Static Electrical Characteristics .....	13
3.6	Dynamic Electrical Characteristics .....	19
3.7	Thermal Protection Characteristics .....	32
3.8	ESD Protection and Latch-up Immunity .....	32
3.9	Additional Test Information ISO7637-2 .....	33
4	Functional Description and Application Information .....	34
4.2	MM912F634 - Analog Die Overview .....	47
4.3	Modes of Operation .....	50
4.4	Power Supply .....	54
4.5	Die to Die Interface - Target .....	57
4.6	Interrupts .....	58
4.7	Resets .....	62
4.8	Wake-up / Cyclic Sense .....	63
4.9	Window Watchdog .....	67
4.10	Hall Sensor Supply Output - HSUP .....	68
4.11	High-side Drivers - HS .....	69
4.12	Low-side Drivers - LSx .....	71
4.13	PWM Control Module (PWM8B2C) .....	77
4.14	LIN Physical Layer Interface - LIN .....	91
4.15	Serial Communication Interface (S08SCIV4) .....	92
4.16	High Voltage Inputs - Lx .....	105
4.17	General Purpose I/O - PTB[0...2] .....	106
4.18	Basic Timer Module - TIM (TIM16B4C) .....	109
4.19	Analog Digital Converter - ADC .....	121
4.20	Current Sense Module - ISENSE .....	129
4.21	Temperature Sensor - TSENSE .....	131
4.22	Supply Voltage Sense - VSENSE .....	131
4.23	Internal Supply Voltage Sense - VS1SENSE .....	132
4.24	Internal Bandgap Reference Voltage Sense - BANDGAP .....	132
4.25	MM912F634 - Analog Die Trimming .....	132
4.26	MM912F634 - MCU Die Overview .....	136
4.27	Port Integration Module (9S12I32PIMV1) .....	143
4.28	Memory Mapping Control (S12SMMCV1) .....	151
4.29	Interrupt Module (S12SINTV1) .....	163
4.30	Background Debug Module (S12SBDMV1) .....	167
4.31	S12S Debug (S12SDBGV1) Module .....	183
4.32	S12S Clocks and Reset Generator (S12SCRGV1) .....	211
4.33	External Oscillator (S12SOSCFPV1) .....	222
4.34	Real Time Interrupt (S12SRTIV1) .....	224
4.35	Computer Operating Properly (S12SCOPV1) .....	228
4.36	32 kbyte Flash Module (S12SFTSR32KV1) .....	233
4.37	Die-to-Die Initiator (D2DIV1) .....	260
4.38	Serial Peripheral Interface (S12SPIV4) .....	271
5	Packaging .....	289
5.1	Package Dimensions .....	289
6	Revision History .....	294

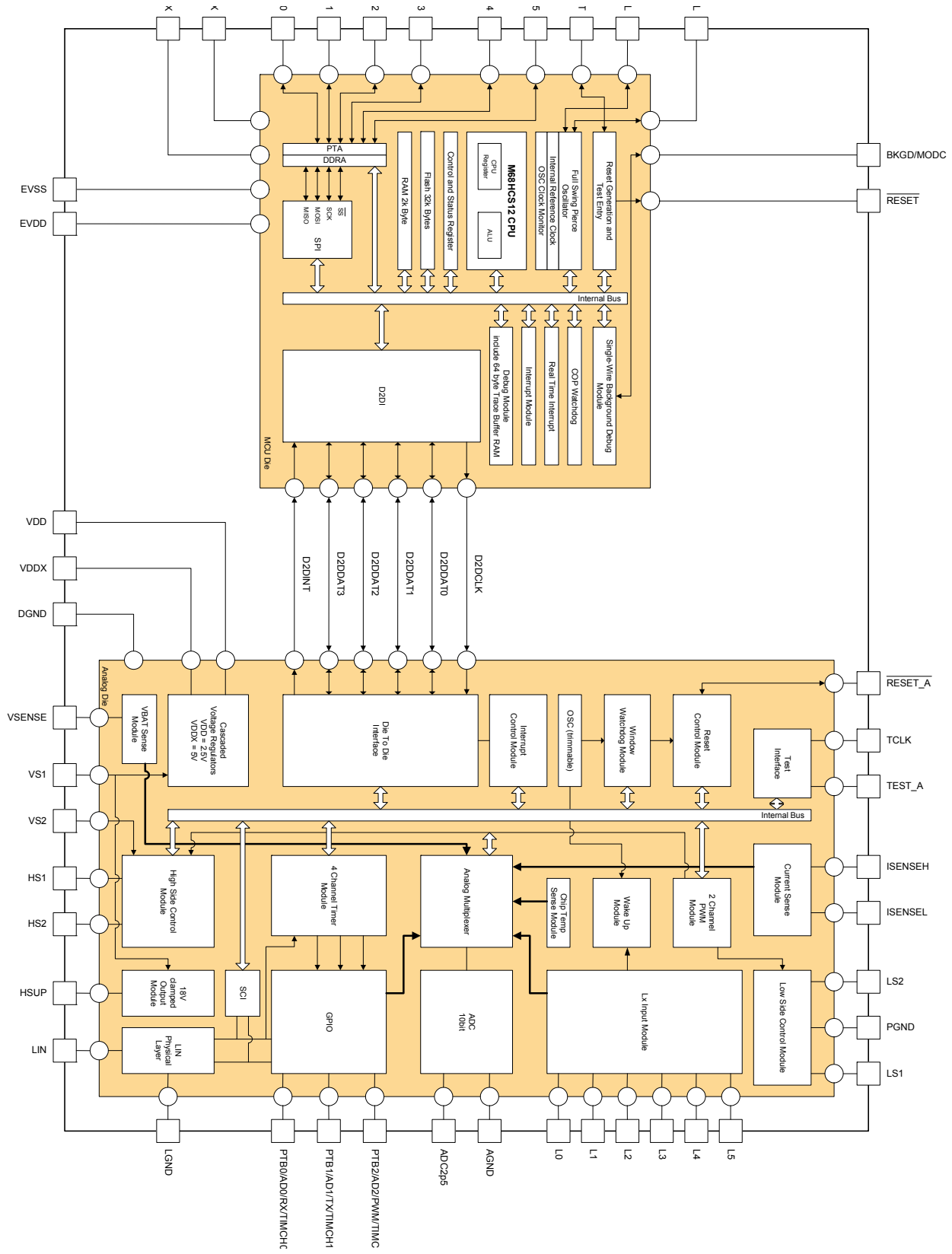

**Figure 3. Device Block Diagram**

## 2 Pin Assignment

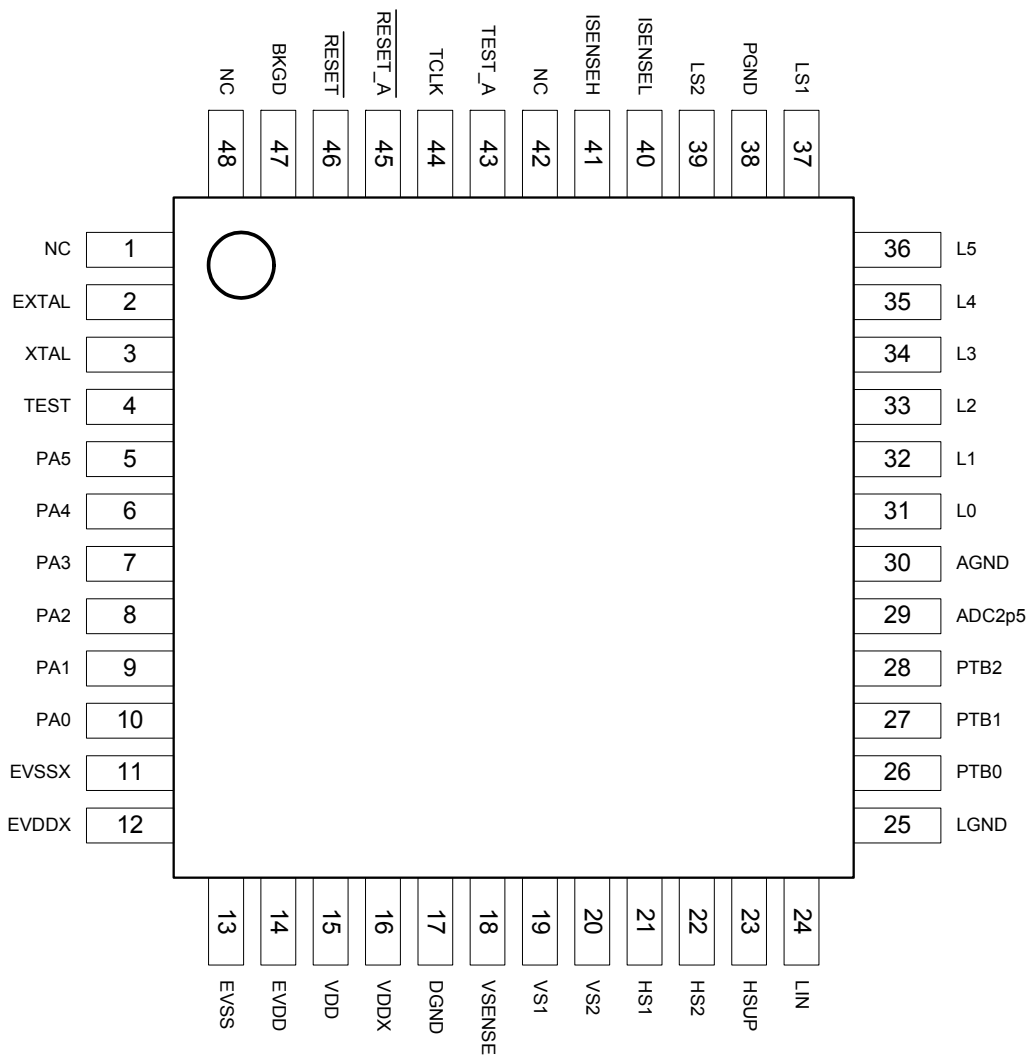

Figure 4. MM912F634 Pin Out

### NOTE

The device exposed pad (package option AE only) is recommended to be connected to GND.

Not all pins are available for analog die option 2. See [Section 4.2.3, "Analog Die Options"](#) for details.

### 2.1 MM912F634 Pin Description

The following table gives a brief description of all available pins on the MM912F634 package. Refer to the highlighted chapter for detailed information.

Table 3. MM912F634 Pin Description

Pin #	Pin Name	Formal Name	Description
1	NC	Not connected Pin	This pin is reserved for alternative function and should be left floating or connected to GND.
2	EXTAL	MCU Oscillator Pin	EXTAL is one of the optional crystal/resonator driver and external clock pins. On reset, all the device clocks are derived from the Internal Reference Clock. See <a href="#">Section 4.33, "External Oscillator (S12SOSCFV1)"</a> .

**Table 3. MM912F634 Pin Description (continued)**

Pin #	Pin Name	Formal Name	Description
3	XTAL	MCU Oscillator Pin	XTAL is one of the optional crystal/resonator driver and external clock pins. On reset, all the device clocks are derived from the Internal Reference Clock. See <a href="#">Section 4.33, "External Oscillator (S12SOSCFPV1)"</a> .
4	TEST	MCU Test Pin	This input only pin is reserved for test. This pin has a pull-down device. The TEST pin must be tied to EVSS in user mode.
5	PA5	MCU PA5 Pin	General purpose port A input or output pin 5. See <a href="#">Section 4.27, "Port Integration Module (9S12I32PIMV1)"</a> .
6	PA4	MCU PA4 Pin	General purpose port A input or output pin 4. See <a href="#">Section 4.27, "Port Integration Module (9S12I32PIMV1)"</a> .
7	PA3	MCU PA3 / $\overline{SS}$ Pin	General purpose port A input or output pin 3, shared with the $\overline{SS}$ signal of the integrated SPI Interface. See <a href="#">Section 4.27, "Port Integration Module (9S12I32PIMV1)"</a> .
8	PA2	MCU PA2 / SCK Pin	General purpose port A input or output pin 2, shared with the SCLK signal of the integrated SPI Interface. See <a href="#">Section 4.27, "Port Integration Module (9S12I32PIMV1)"</a> .
9	PA1	MCU PA1 / MOSI Pin	General purpose port A input or output pin 1, shared with the MOSI signal of the integrated SPI Interface. See <a href="#">Section 4.27, "Port Integration Module (9S12I32PIMV1)"</a> .
10	PA0	MCU PA0 / MISO Pin	General-purpose port A input or output pin 0, shared with the MISO signal of the integrated SPI Interface. See <a href="#">Section 4.27, "Port Integration Module (9S12I32PIMV1)"</a> .
11	EVSSX	MCU 5.0 V Ground Pin	Ground for the MCU 5.0 V power supply.
12	EVDDX	MCU 5.0 V Supply Pin	MCU 5.0 V - I/O buffer supply. See <a href="#">Section 4.26, "MM912F634 - MCU Die Overview"</a> .
13	EVSS	MCU 2.5 V Ground Pin	Ground for the MCU 2.5 V power supply.
14	EVDD	MCU 2.5 V Supply Pin	MCU 2.5 V - MCU Core- and Flash power supply. See <a href="#">Section 4.26, "MM912F634 - MCU Die Overview"</a> .
15	VDD	Voltage Regulator Output 2.5 V	+2.5 V main voltage regulator output pin. External capacitor ( $C_{VDD}$ ) needed. See <a href="#">Section 4.4, "Power Supply"</a> .
16	VDDX	Voltage Regulator Output 5.0 V	+5.0 V main voltage regulator output pin. External capacitor ( $C_{VDDX}$ ) needed. See <a href="#">Section 4.4, "Power Supply"</a> .
17	DGND	Digital Ground Pin	This pin is the device digital ground connection for the 5.0 V and 2.5 V logic. DGND, LGND, and AGND are internally connected to PGND via a back to back diode.
18	VSENSE	Voltage Sense Pin	Battery voltage sense input. This pin can be connected directly to the battery line for voltage measurements. The voltage present at this input is scaled down by an internal voltage divider, and can be routed to the internal ADC via the analog multiplexer. The pin is self-protected against reverse battery connections. An external resistor ( $R_{VSENSE}$ ) is needed for protection <sup>(4)</sup> . See <a href="#">Section 4.22, "Supply Voltage Sense - VSENSE"</a> .
19	VS1	Power Supply Pin 1	This pin is the device power supply pin 1. VS1 is primarily supplying the VDDX Voltage regulator and the Hall Sensor Supply Regulator (HSUP). VS1 can be sensed via a voltage divider through the AD converter. Reverse battery protection diode is required. See <a href="#">Section 4.4, "Power Supply"</a> .
20	VS2	Power Supply Pin 2	This pin is the device power supply pin 2. VS2 supplies the High-side Drivers (HSx). Reverse battery protection diode required. See <a href="#">Section 4.4, "Power Supply"</a> .
21	HS1	High-side Output 1	This pin is the first High-side output. It is supplied through the VS2 pin. It is designed to drive small resistive loads with optional PWM. In cyclic sense mode, this output activates periodically during low power mode. See <a href="#">Section 4.11, "High-side Drivers - HS"</a> .
22	HS2	High-side Output 2	This pin is the second High-side output. It is supplied through the VS2 pin. It is designed to drive small resistive loads with optional PWM. In cyclic sense mode, this output activates periodically during low power mode. See <a href="#">Section 4.11, "High-side Drivers - HS"</a> .
23	HSUP	Hall Sensor Supply Output	This pin is designed as an 18 V Regulator to drive Hall Sensor Elements. It is supplied through the VS1 pin. An external capacitor ( $C_{HSUP}$ ) is needed. See <a href="#">Section 4.10, "Hall Sensor Supply Output - HSUP"</a> .
24	LIN	LIN Bus I/O	This pin represents the single-wire bus transmitter and receiver. See <a href="#">Section 4.14, "LIN Physical Layer Interface - LIN"</a> .
25	LGND	LIN Ground Pin	This pin is the device LIN Ground connection. DGND, LGND, and AGND are internally connected to PGND via a back to back diode.

**Table 3. MM912F634 Pin Description (continued)**

Pin #	Pin Name	Formal Name	Description
26	PTB0	General Purpose I/O 0	This is the General Purpose I/O pin 0 based on VDDX with the following shared functions: <ul style="list-style-type: none"> <li>• PTB0 - Bidirectional 5.0 V (VDDX) digital port I/O with selectable internal pull-up resistor.</li> <li>• AD0 - Analog Input Channel 0, 0...2.5 V (ADC2p5) analog input</li> <li>• TIM0CH0 - Timer Channel 0 Input/Output</li> <li>• Rx - Selectable connection to LIN / SCI</li> </ul> See <a href="#">Section 4.17, "General Purpose I/O - PTB[0...2]"</a> .
27	PTB1	General Purpose I/O 1	This is the General Purpose I/O pin 1 based on VDDX with the following shared functions: <ul style="list-style-type: none"> <li>• PTB1 - Bidirectional 5.0 V (VDDX) digital port I/O with selectable internal pull-up resistor.</li> <li>• AD1 - Analog Input Channel 1, 0...2.5 V (ADC2p5) analog input</li> <li>• TIM0CH1 - Timer Channel 1 Input/Output</li> <li>• Tx - Selectable connection to LIN / SCI</li> </ul> See <a href="#">Section 4.17, "General Purpose I/O - PTB[0...2]"</a> .
28	PTB2	General Purpose I/O 2	This is the General Purpose I/O pin 2 based on VDDX with the following shared functions: <ul style="list-style-type: none"> <li>• PTB2 - Bidirectional 5.0 V (VDDX) digital port I/O with selectable internal pull-up resistor.</li> <li>• AD2 - Analog Input Channel 2, 0...2.5 V (ADC2p5) analog input</li> <li>• TIM0CH2 - Timer Channel 2 Input/Output</li> <li>• PWM - Selectable connection to PWM Channel 0 or 1</li> </ul> See <a href="#">Section 4.17, "General Purpose I/O - PTB[0...2]"</a> .
29	ADC2p5	ADC Reference Voltage	This pin represents the ADC reference voltage and has to be connected to a filter capacitor. See <a href="#">Section 4.19, "Analog Digital Converter - ADC"</a>
30	AGND	Analog Ground Pin	This pin is the device Analog to Digital Converter ground connection. DGND, LGND and AGND are internally connected to PGND via a back to back diode.
31	L0	High Voltage Input 0	This pins is the High Voltage Input 0 with the following shared functions: <ul style="list-style-type: none"> <li>• L0 - Digital High Voltage Input 0. When used as digital input, a series resistor (<math>R_{Lx}</math>) must be used to protect against automotive transients.<sup>(5)</sup></li> <li>• AD3 - Analog Input 3 with selectable divider for 0...5.0 V and 0...18 V measurement range.</li> <li>• WU0 - Selectable Wake-up input 0 for wake up and cyclic sense during low power mode.</li> </ul> See <a href="#">Section 4.16, "High Voltage Inputs - Lx"</a>
32	L1	High Voltage Input 1	This pins is the High Voltage Input 1 with the following shared functions: <ul style="list-style-type: none"> <li>• L1 - Digital High Voltage Input 1. When used as digital input, a series resistor (<math>R_{Lx}</math>) must be used to protect against automotive transients.<sup>(5)</sup></li> <li>• AD4 - Analog Input 4 with selectable divider for 0...5.0 V and 0...18 V measurement range.</li> <li>• WU1 - Selectable Wake-up input 1 for wake-up and cyclic sense during low power mode.</li> </ul> See <a href="#">Section 4.16, "High Voltage Inputs - Lx"</a> .
33	L2	High Voltage Input 2	This pins is the High Voltage Input 2 with the following shared functions: <ul style="list-style-type: none"> <li>• L2 - Digital High Voltage Input 2. When used as digital input, a series resistor (<math>R_{Lx}</math>) must be used to protect against automotive transients.<sup>(5)</sup></li> <li>• AD5 - Analog Input 5 with selectable divider for 0...5.0 V and 0...18 V measurement range.</li> <li>• WU2 - Selectable Wake-up input 2 for wake-up and cyclic sense during low power mode.</li> </ul> See <a href="#">Section 4.16, "High Voltage Inputs - Lx"</a> .
34	L3	High Voltage Input 3	This pins is the High Voltage Input 3 with the following shared functions: <ul style="list-style-type: none"> <li>• L3 - Digital High Voltage Input 3. When used as digital input, a series resistor (<math>R_{Lx}</math>) must be used to protect against automotive transients.<sup>(5)</sup></li> <li>• AD6 - Analog Input 6 with selectable divider for 0...5.0 V and 0...18 V measurement range.</li> <li>• WU3 - Selectable Wake-up input 3 for wake-up and cyclic sense during low power mode.</li> </ul> See <a href="#">Section 4.16, "High Voltage Inputs - Lx"</a> .
35	L4	High Voltage Input 4	This pins is the High Voltage Input 4 with the following shared functions: <ul style="list-style-type: none"> <li>• L4 - Digital High Voltage Input 4. When used as digital input, a series resistor (<math>R_{Lx}</math>) must be used to protect against automotive transients.<sup>(5)</sup></li> <li>• AD7 - Analog Input 7 with selectable divider for 0...5.0 V and 0...18 V measurement range.</li> <li>• WU4 - Selectable Wake-up input 4 for wake-up and cyclic sense during low power mode.</li> </ul> See <a href="#">Section 4.16, "High Voltage Inputs - Lx"</a> . Note: This pin function is not available on all device configurations.

**Table 3. MM912F634 Pin Description (continued)**

Pin #	Pin Name	Formal Name	Description
36	L5	High Voltage Input 5	This pins is the High Voltage Input 5 with the following shared functions: <ul style="list-style-type: none"> <li>L5 - Digital High Voltage Input 5. When used as digital input, a series resistor (<math>R_{Lx}</math>) must be used to protect against automotive transients.<sup>(5)</sup></li> <li>AD8 - Analog Input 8 with selectable divider for 0...5.0 V and 0...18 V measurement range.</li> <li>WU5 - Selectable Wake-up input 5 for wake-up and cyclic sense during low power mode.</li> </ul> See Section 4.16, "High Voltage Inputs - Lx". Note: This pin function is not available on all device configurations.
37	LS1	Low-side Output 1	Low-side output 1 used to drive small inductive loads like relays. The output is short-circuit protected, includes active clamp circuitry and can be also controlled by the PWM module. See Section 4.12, "Low-side Drivers - LSx".
38	PGND	Power Ground Pin	This pin is the device Low-side Ground connection. DGND, LGND and AGND are internally connected to PGND via a back to back diode.
39	LS2	Low-side Output 2	Low-side output 2 used to drive small inductive loads like relays. The output is short-circuit protected, includes active clamp circuitry and can be also controlled by the PWM module. See Section 4.12, "Low-side Drivers - LSx".
40	ISENSEL	Current Sense Pins L	Current Sense differential input "Low". This pin is used in combination with ISENSEH to measure the voltage drop across a shunt resistor. See Section 4.20, "Current Sense Module - ISENSE". Note: This pin function is not available on all device configurations.
41	ISENSEH	Current Sense Pins H	Current Sense differential input "High". This pin is used in combination with ISENSEL to measure the voltage drop across a shunt resistor. Section 4.20, "Current Sense Module - ISENSE". Note: This pin function is not available on all device configurations.
42	NC	Not connected Pin	This pin is reserved for alternative function and should be left floating.
43	TEST_A	Test Mode Pin	Analog die Test Mode pin for Test Mode only. This pin must be grounded in user mode.
44	TCLK	Test Clock Input	Test Mode Clock Input pin for Test Mode only. The pin can be used to disable the internal watchdog for development purpose in user mode. See Section 4.9, "Window Watchdog". The pin is recommended to be grounded in user mode.
45	$\overline{\text{RESET\_A}}$	Reset I/O	Bidirectional Reset I/O pin of the analog die. Active low signal. Internal pull-up. $V_{DDX}$ based. See Section 4.7, "Resets". To be externally connected to the RESET pin.
46	$\overline{\text{RESET}}$	MCU Reset Pin	The RESET pin is an active low bidirectional control signal. It acts as an input to initialize the MCU to a known start-up state, and an output when an internal MCU function causes a reset. The RESET pin has an internal pull-up device to EVDDX.
47	BKGD	MCU Background Debug and Mode Pin	The BKGD/MODC pin is used as a pseudo-open-drain pin for the background debug communication. It is used as MCU operating mode select pin during reset. The state of this pin is latched to the MODC bit at the rising edge of RESET. The BKGD pin has a pull-up device.
48	NC	Not connected Pin	This pin is reserved for alternative function and should be left floating or connected to GND.

Note:

- An optional filter capacitor  $C_{VSENSE}$  is recommended to be placed between the board connector and  $R_{VSENSE}$  to GND for increased ESD performance.
- An optional filter capacitor  $C_{Lx}$  is recommended to be placed between the board connector and  $R_{Lx}$  to GND for increased ESD performance.

## 2.2 MCU Die Signal Properties

This section describes the external MCU signals. It includes a table of signal properties.

**Table 4. Signal Properties Summary**

Pin Name Function 1	Pin Name Function 2	Power Supply	Internal Pull Resistor		Description
			CTRL	Reset State	
EXTAL	—	$V_{DD}$	NA	NA	Oscillator pins
XTAL	—	$V_{DD}$	NA	NA	
$\overline{\text{RESET}}$	—	$V_{DDX}$	Pull-up		External reset

Table 4. Signal Properties Summary (continued)

Pin Name Function 1	Pin Name Function 2	Power Supply	Internal Pull Resistor		Description
			CTRL	Reset State	
TEST	—	N.A.	$\overline{\text{RESET}}$ pin	Down	Test input
BKGD	MODC	$V_{DDX}$	Always on	UP	Background debug
PA5	—	$V_{DDX}$	NA	NA	Port A I/O
PA4	—	$V_{DDX}$	NA	NA	Port A I/O
PA3	SS	$V_{DDX}$	NA	NA	Port A I/O, SPI
PA2	SCK	$V_{DDX}$	NA	NA	Port A I/O, SPI
PA1	MOSI	$V_{DDX}$	NA	NA	Port A I/O, SPI
PA0	MISO	$V_{DDX}$	NA	NA	Port A I/O, SPI

### 3 Electrical Characteristics

#### 3.1 General

This supplement contains electrical information for the embedded MC9S12I32 microcontroller die, as well as the MM912F634 analog die.

#### 3.2 Absolute Maximum Ratings

Absolute maximum ratings are stress ratings only. A functional operation under or outside those maxima is not guaranteed. Stress beyond those limits may affect the reliability or cause permanent damage of the device.

This device contains circuitry protecting against damage due to high static voltage or electrical fields. However, it is advised that normal precautions be taken to avoid application of any voltages higher than maximum-rated voltages to this high-impedance circuit. Reliability of operation is enhanced if unused inputs are tied to an appropriate voltage level. All voltages are with respect to ground unless otherwise noted.

**Table 5. Absolute Maximum Electrical Ratings - Analog Die**

Ratings	Symbol	Value	Unit
Supply Voltage at VS1 and VS2 Normal Operation (DC) Transient Conditions (load dump) Transient input voltage with external component (according to LIN Conformance Test Specification / ISO7637-2)	$V_{SUP(SS)}$ $V_{SUP(PK)}$ $V_{SUP(TR)}$	-0.3 to 27 -0.3 to 40 see <a href="#">Section 3.9</a> , "Additional Test Information ISO7637-2"	V
L0...L5 - Pin Voltage Normal Operation with a series $R_{LX}$ resistor (DC) Transient input voltage with external component (according to LIN Conformance Test Specification / ISO7637-2)	$V_{LxDC}$ $V_{LxTR}$	-27 to 40 see <a href="#">Section 3.9</a> , "Additional Test Information ISO7637-2"	V
LIN Pin Voltage Normal Operation (DC) Transient input voltage with external component (according to LIN Conformance Test Specification / ISO7637-2)	$V_{BUSDC}$ $V_{BUSTR}$	-33 to 40 see <a href="#">Section 3.9</a> , "Additional Test Information ISO7637-2"	V
Supply Voltage at VDDX	$V_{DDX}$	-0.3 to 5.5	V
Supply Voltage at VDD <sup>(6)</sup>	$V_{DD}$	-0.3 to 2.75	V
VDD output current	$I_{VDD}$	Internally Limited	A
VDDX output current	$I_{VDDX}$	Internally Limited	A
TCLK Pin Voltage	$V_{TCLK}$	-0.3 to 10	V
RESET_A Pin Voltage	$V_{IN}$	-0.3 to $V_{DDx}+0.3$	V
Input / Output Pins PTB[0:2] Voltage	$V_{IN}$	-0.3 to $V_{DDx}+0.3$	V
HS1 and HS2 Pin Voltage (DC)	$V_{HS}$	-0.3 to $VS2+0.3$	V
LS1 and LS2 Pin Voltage (DC)	$V_{LS}$	-0.3 to 45	V
ISENSEH and ISENSEL Pin Voltage (DC)	$V_{ISENSE}$	-0.3 to 40	V
HSUP Pin Voltage (DC)	$V_{HSUP}$	-0.3 to $VS1+0.3$	V
VSENSE Pin Voltage (DC)	$V_{VSENSE}$	-27 to 40	V

Note:

- Caution: As this pin is adjacent to the VDDX pin, care should be taken to avoid a short between VDD and VDDX, for example, during the soldering process. A short-circuit between these pins might lead to permanent damage.

**Table 6. Maximum Electrical Ratings - MCU Die**

Ratings	Symbol	Value	Unit
5.0 V Supply Voltage	$V_{EDDX}$	-0.3 to 6.0	V
2.5 V Supply Voltage	$V_{EDD}$	-0.3 to 2.75	V
Digital I/O input voltage (PA0...PA7, PE0, PE1)	$V_{IN}$	-0.3 to 6.0	V
EXTAL, XTAL	$V_{ILV}$	-0.3 to 2.16	V
TEST input	$V_{TEST}$	-0.3 to 10.0	V
Instantaneous maximum current Single pin limit for all digital I/O pins	$I_D$	-25 to 25	mA
Instantaneous maximum current Single pin limit for EXTAL, XTAL	$I_{DL}$	-25 to 25	mA

**Table 7. Maximum Thermal Ratings**

Ratings	Symbol	Value	Unit
Storage Temperature	$T_{STG}$	-55 to 150	°C
Package Thermal Resistance - LQFP48-EP Four layer board (JEDEC 2s2p) Junction to Ambient Natural Convection <sup>(7)</sup> Junction to Board <sup>(9)</sup> Two layer board (JEDEC 1s) Junction to Ambient Natural Convection <sup>(7), (8)</sup>	$R_{\theta JA}$ $R_{\theta JB}$ $R_{\theta JA}$	39 16 91	°C/W
Package Thermal Resistance - LQFP48 Four layer board (JEDEC 2s2p) Junction to Ambient Natural Convection <sup>(7)</sup> Junction to Board <sup>(9)</sup> Two layer board (JEDEC 1s) Junction to Ambient Natural Convection <sup>(7), (8)</sup>	$R_{\theta JA}$ $R_{\theta JB}$ $R_{\theta JA}$	59 31 96	°C/W
Peak Package Reflow Temperature During Reflow <sup>(10),(11)</sup>	$T_{PPRT}$	300	°C

**Notes**

7. Junction temperature is a function of die size, on-chip power dissipation, package thermal resistance, mounting site (board) temperature, ambient temperature, air flow, power dissipation of other components on the board, and board thermal resistance.
8. Per JEDEC JESD51-6 with the board (JESD51-7) horizontal.
9. Thermal resistance between the die and the printed circuit board per JEDEC JESD51-8. Board temperature is measured on the top surface of the board near the package.
10. Pin soldering temperature limit is for 10 seconds maximum duration. Not designed for immersion soldering. Exceeding these limits may cause malfunction or permanent damage to the device.
11. Freescale's Package Reflow capability meets Pb-free requirements for JEDEC standard J-STD-020C. For Peak Package Reflow Temperature and Moisture Sensitivity Levels (MSL), Go to [www.freescale.com](http://www.freescale.com), search by part number [e.g. remove prefixes/suffixes and enter the core ID to view all orderable parts. (i.e. MC34xxx enter 34xxx), and review parametrics.

### 3.3 Operating Conditions

This section describes the operating conditions of the device. Unless otherwise noted those conditions apply to all the following data.

**Table 8. Operating Conditions**

Ratings	Symbol	Value	Unit
Analog Die Nominal Operating Voltage	$V_{SUP}$	5.5 to 18	V
Analog Die Functional Operating Voltage - Device is fully functional. All features are operating.	$V_{SUPOP}$	5.5 to 27	V
MCU I/O and supply voltage <sup>(12)</sup>	$V_{EDDX}$	4.5 to 5.5	V

**Table 8. Operating Conditions (continued)**

Ratings	Symbol	Value	Unit
MCU Digital logic supply voltage <sup>(12)</sup>	$V_{EDD}$	2.25 to 2.75	V
MCU External Oscillator	$f_{OSC}$	4.0 to 16	MHz
MCU Bus frequency	$f_{BUS}$	$f_{BUSMAX}$ <sup>(13)</sup>	MHz
Operating Ambient Temperature, MM912x634xVxxx	$T_A$	-40 to 105	°C
Operating Junction Temperature - Analog Die	$T_{J\_A}$	-40 to 150	°C
Operating Junction Temperature - MCU Die	$T_{J\_M}$	-40 to 140	°C

Note:

12. During power up and power down sequence always  $V_{DD} < V_{DDX}$
13.  $f_{BUSMAX}$  frequency ratings differ by device and is specified in [Table 1](#)

## 3.4 Supply Currents

This section describes the current consumption characteristics of the device as well as the conditions for the measurements.

### 3.4.1 Measurement Conditions

All measurements are without output loads. Unless otherwise noted, the currents are measured in MCU special single chip mode and the CPU code is executed from RAM.

**Table 9. Supply Currents**

Ratings	Symbol	Min	Typ <sup>(14)</sup>	Max	Unit
Normal Mode analog die only, excluding external loads, LIN Recessive State ( $5.5\text{ V} \leq V_{SUP} \leq 18\text{ V}$ , $2.25\text{ V} \leq E_{VDD} \leq 2.75\text{ V}$ , $4.5\text{ V} \leq E_{VDDX} \leq 5.5\text{ V}$ , $-40\text{ °C} \leq T_{J\_A} \leq 150\text{ °C}$ ).	$I_{RUN\_A}$	-	5.0	8.0	mA
Normal Mode MCU die only ( $T_{J\_M} = 140\text{ °C}$ ; $V_{DD} = 2.75\text{ V}$ , $V_{DDX} = 5.5\text{ V}$ , $f_{OSC} = 4.0\text{ MHz}$ , $f_{BUS} = f_{BUSMAX}$ <sup>(18)(15)</sup> )	$I_{RUN\_M}$	-	12.5	15	mA
Stop Mode internal analog die only, excluding external loads, LIN Recessive State, Lx enabled, measured at VS1+VS2 ( $5.5\text{ V} \leq V_{SUP} \leq 18\text{ V}$ , $2.25\text{ V} \leq E_{VDD} \leq 2.75\text{ V}$ , $4.5\text{ V} \leq E_{VDDX} \leq 5.5\text{ V}$ ) -40 °C ≤ T <sub>J_A</sub> ≤ 125 °C 125 °C < T <sub>J_A</sub> ≤ 140 °C	$I_{STOP\_A}$	- -	20 -	40 50	µA
Stop Mode MCU die only ( $V_{DD} = 2.75\text{ V}$ , $V_{DDX} = 5.5\text{ V}$ , $f_{OSC} = 4.0\text{ MHz}$ , $f_{BUS} = f_{BUSMAX}$ <sup>(18)</sup> ; MCU in STOP; RTI and COP off) <sup>(16)</sup> $T_{J\_M} = 140\text{ °C}$ $T_{J\_M} = 105\text{ °C}$ $T_{J\_M} = 25\text{ °C}$	$I_{STOP\_M}$	- - -	0.135 0.035 0.010	0.400 0.200 0.030	mA
Stop Mode MCU die only ( $V_{DD} = 2.75\text{ V}$ , $V_{DDX} = 5.5\text{ V}$ , $f_{OSC} = 4.0\text{ MHz}$ , $f_{BUS} = f_{BUSMAX}$ <sup>(18)</sup> ; MCU in STOP; RTI and COP on) <sup>(16)</sup> $T_{J\_M} = 140\text{ °C}$ $T_{J\_M} = 105\text{ °C}$ $T_{J\_M} = 25\text{ °C}$	$I_{STOP\_M}$	- - -	0.205 0.104 0.079	0.500 0.300 0.110	mA
Wait Mode MCU die only ( $T_{J\_M} = 140\text{ °C}$ ; $V_{DD} = 2.75\text{ V}$ , $V_{DDX} = 5.5\text{ V}$ , $f_{OSC} = 4.0\text{ MHz}$ , $f_{BUS} = f_{BUSMAX}$ <sup>(18)</sup> ; All modules except RTI disabled) <sup>(17)</sup>	$I_{WAIT\_M}$	-	7.0	12	mA
Sleep Mode ( $V_{DD} = V_{DDX} = \text{OFF}$ ; $5.5\text{ V} \leq V_{SUP} \leq 18\text{ V}$ ; $-40\text{ °C} \leq T_{J\_A} \leq 150\text{ °C}$ ; $3.0\text{ V} < L_X < 1.0\text{ V}$ ).	$I_{SLEEP}$	-	15	28	µA
Cyclic Sense Supply Current Adder (5.0 ms Cycle)	$I_{CS}$	-	15	20	µA

Note:

14. Typical values noted reflect the approximate parameter mean at  $T_A = 25\text{ °C}$
15.  $I_{RUN\_M}$  denotes the sum of the currents flowing into VDD and VDDX.
16.  $I_{STOP\_M}$  denotes the sum of the currents flowing into VDD and VDDX.
17.  $I_{WAIT\_M}$  denotes the sum of the currents flowing into VDD and VDDX.
18.  $f_{BUSMAX}$  frequency ratings differ by device and is specified in [Table 1](#).

### 3.5 Static Electrical Characteristics

Static electrical characteristics noted under conditions  $5.5V \leq VSUP \leq 18V$ ,  $-40^\circ C \leq T_A \leq 105^\circ C$ , unless otherwise noted. Typical values noted reflect the approximate parameter mean at  $T_A = 25^\circ C$  under nominal conditions unless otherwise noted.

#### 3.5.1 Static Electrical Characteristics Analog Die

**Table 10. Static Electrical Characteristics - Power Supply**

Ratings	Symbol	Min	Typ	Max	Unit
Power-On Reset (POR) Threshold (measured on VS1)	$V_{POR}$	1.5	-	3.5	V
Low Voltage Warning (LVI) Threshold (measured on VS1, falling edge) Hysteresis (measured on VS1)	$V_{LVI}$ $V_{LVI\_H}$	5.55 -	6.0 1.0	6.6 -	V
High Voltage Warning (HVI) Threshold (measured on VS2, rising edge) Hysteresis (measured on VS2)	$V_{HVI}$ $V_{HVI\_H}$	18 -	19.25 1.0	20.5 -	V
Low Battery Warning (LBI) Threshold (measured on VSENSE, falling edge) Hysteresis (measured on VSENSE)	$V_{LBI}$ $V_{LBI\_H}$	5.55 -	6.0 1.0	6.6 -	V
J2602 Undervoltage threshold	$V_{J2602UV}$	5.5	5.7	6.2	V
Low VDDX Voltage (LVRX) Threshold	$V_{LVRX}$	2.7	3.0	3.3	V
Low VDD Voltage Reset (LVR) Threshold Normal Mode	$V_{LVR}$	2.30	2.35	2.4	V
Low VDD Voltage Reset (LVR) Threshold Stop Mode <sup>(19)</sup>	$V_{LVRS}$	1.6	1.85	2.1	V
VDD Overvoltage Threshold (VROV)	$V_{VDDOV}$	2.575	2.7875	3.0	V
VDDX Overvoltage Threshold (VROVX)	$V_{VDDXOV}$	5.25	5.675	6.1	V

Note:

19. See MM912F634ER, MM912F634, Silicon Analog Mask (M91W) / Digital Mask (M33G) Errata

**Table 11. Static Electrical Characteristics - Resets**

Ratings	Symbol	Min	Typ	Max	Unit
Low-state Output Voltage $I_{OUT} = 2.0\text{ mA}$	$V_{OL}$	-	-	0.8	V
Pull-up Resistor	$R_{RPU}$	25	-	50	k $\Omega$
Low-state Input Voltage	$V_{IL}$	-	-	0.3V <sub>DDX</sub>	V
High-state Input Voltage	$V_{IH}$	0.7V <sub>DDX</sub>	-	-	V
Reset Release Voltage (VDDX)	$V_{RSTRV}$	-	1.5	-	V
RESET_A pin Current Limitation		5.0	7.5	10	mA

**Table 12. Static Electrical Characteristics - Window Watchdog**

Ratings	Symbol	Min	Typ	Max	Unit
Watchdog Disable Voltage (fixed voltage)	$V_{TST}$	7.0	-	10	V
Watchdog Enable Voltage (fixed voltage)	$V_{TSTEN}$	-	-	5.5	V

**Table 13. Static Electrical Characteristics - Voltage Regulator 5V (VDDX)**

Ratings	Symbol	Min	Typ	Max	Unit
Normal Mode Output Voltage 1.0 mA < I <sub>VDDX</sub> + I <sub>VDDXINTERNAL</sub> < 80 mA; 5.5 V < V <sub>SUP</sub> < 27 V (20)	V <sub>DDEX</sub> RUN	4.75	5.00	5.25	V
Normal Mode Output Current Limitation (I <sub>VDDX</sub> )	I <sub>VDDXLIM</sub> RUN	80	130	200	mA
Stop Mode Output Voltage (I <sub>VDDX</sub> + I <sub>VDDXINTERNAL</sub> < 500 μA for T <sub>J</sub> ≥ 25 °C; I <sub>VDDX</sub> + I <sub>VDDXINTERNAL</sub> < 400 μA for T <sub>J</sub> < 25 °C) (20)	V <sub>DDEX</sub> STOP	-	5.0	5.5	V
Stop Mode Output Current Limitation (I <sub>VDDX</sub> )	I <sub>VDDXLIM</sub> STOP	-	-	20	mA
Line Regulation Normal Mode, I <sub>VDDX</sub> = 80 mA Stop Mode, I <sub>VDDX</sub> = 500 μA	LR <sub>X</sub> RUN LR <sub>X</sub> STOP	- -	20 -	25 200	mV
Load Regulation Normal Mode, 1.0 mA < I <sub>VDDX</sub> < 80 mA Normal Mode, V <sub>SUP</sub> = 3.6 V, 1.0 mA < I <sub>VDDX</sub> < 40 mA Stop Mode, 100 μA < I <sub>VDDX</sub> < 500 μA	LD <sub>X</sub> RUN LD <sub>X</sub> CRK LD <sub>X</sub> STOP	- - -	15 - -	80 200 250	mV
External Capacitor	C <sub>VDDX</sub>	1.0	-	10	μF
External Capacitor ESR	C <sub>VDDX_R</sub>	-	-	10	Ω

Note:

20. I<sub>VDDXINTERNAL</sub> includes internal consumption from both analog and MCU die.

**Table 14. Static Electrical Characteristics - Voltage Regulator 2.5 V (VDD)**

Ratings	Symbol	Min	Typ	Max	Unit
Normal Mode Output Voltage 1.0 mA < I <sub>VDD</sub> + I <sub>VDDINTERNAL</sub> ≤ 45 mA; 5.5 V < V <sub>SUP</sub> < 27 V (21)	V <sub>DD</sub> RUN	2,425	2.5	2,575	V
Normal Mode Output Current Limitation (I <sub>VDD</sub> ) T <sub>J</sub> < 25 °C T <sub>J</sub> ≥ 25 °C	I <sub>VDDLIM</sub> RUN	- -	80 80	120 143	mA
Stop Mode Output Voltage (I <sub>VDD</sub> + I <sub>VDDINTERNAL</sub> < 500 μA for T <sub>J</sub> ≥ 25 °C; I <sub>VDD</sub> + I <sub>VDDINTERNAL</sub> < 400 μA for T <sub>J</sub> < 25 °C) (21)	V <sub>DD</sub> STOP	2.25	2.5	2.75	V
Stop Mode Output Current Limitation (I <sub>VDD</sub> )	I <sub>VDDLIM</sub> STOP	-	-	10	mA
Line Regulation Normal Mode, I <sub>VDD</sub> = 45 mA Stop Mode, I <sub>VDD</sub> = 1.0 mA	LR <sub>R</sub> RUN LR <sub>R</sub> STOP	- -	10 -	12.5 200	mV
Load Regulation Normal Mode, 1.0 mA < I <sub>VDD</sub> < 45 mA Normal Mode, V <sub>SUP</sub> = 3.6 V, 1.0 mA < I <sub>VDD</sub> < 30 mA Stop Mode, 100 μA < I <sub>VDD</sub> < 500 μA	LD <sub>R</sub> RUN LD <sub>R</sub> CRK LD <sub>R</sub> STOP	- - -	7.5 - -	40 40 200	mV
External Capacitor	C <sub>VDD</sub>	1.0	-	10	μF
External Capacitor ESR	C <sub>VDD_R</sub>	-	-	10	Ω

Note:

21. I<sub>VDDINTERNAL</sub> includes internal consumption from both analog and MCU die.

**Table 15. Static Electrical Characteristics - Hall Sensor Supply Output - HSUP**

Ratings	Symbol	Min	Typ	Max	Unit
Current Limitation ( $3.7\text{ V} \leq V_{\text{SUP}} \leq 18\text{ V}$ )	$I_{\text{HSUP}}$	40	70	90	mA
Output Drain-to-Source On resistance $T_{\text{J}} = 150\text{ }^{\circ}\text{C}$ , $I_{\text{LOAD}} = 30\text{ mA}$ ; $5.5\text{ V} \leq V_{\text{SUP}} \leq 16\text{ V}$ $T_{\text{J}} = 150\text{ }^{\circ}\text{C}$ , $I_{\text{LOAD}} = 30\text{ mA}$ ; $3.7\text{ V} \leq V_{\text{SUP}} < 5.5\text{ V}$	$R_{\text{DS(on)}}$	-	-	10 13	$\Omega$
Output Voltage: ( $18\text{ V} \leq V_{\text{SUP}} \leq 27\text{ V}$ )	$V_{\text{HSUP\_MAX}}$	16	17.5	18	V
Load Regulation ( $1.0\text{ mA} < I_{\text{HSUP}} < 30\text{ mA}$ ; $V_{\text{SUP}} > 18\text{ V}$ )	$LD_{\text{HSUP}}$	-	-	500	mV
Hall Supply Capacitor Range	$C_{\text{HSUP}}$	0.22	-	10	$\mu\text{F}$
External Capacitor ESR	$C_{\text{HSUP\_R}}$	-	-	10	$\Omega$

**Table 16. Static Electrical Characteristics - High-side Drivers - HS**

Ratings	Symbol	Min	Typ	Max	Unit
Output Drain-to-Source On resistance $T_{\text{J}} = 25\text{ }^{\circ}\text{C}$ , $I_{\text{LOAD}} = 50\text{ mA}$ ; $V_{\text{SUP}} > 9.0\text{ V}$ $T_{\text{J}} = 150\text{ }^{\circ}\text{C}$ , $I_{\text{LOAD}} = 50\text{ mA}$ ; $V_{\text{SUP}} > 9.0\text{ V}$ $T_{\text{J}} = 150\text{ }^{\circ}\text{C}$ , $I_{\text{LOAD}} = 30\text{ mA}$ ; $5.5\text{ V} < V_{\text{SUP}} < 9.0\text{ V}$	$R_{\text{DS(ON)}}$	-	-	7.0 10 14	$\Omega$
Output Current Limitation ( $0\text{ V} < V_{\text{OUT}} < V_{\text{SUP}} - 2.0\text{ V}$ )	$I_{\text{LIMHSX}}$	60	110	250	mA
Open Load Current Detection	$I_{\text{OLHSX}}$	-	5.0	7.5	mA
Leakage Current ( $-0.2\text{ V} < V_{\text{HSX}} < V_{\text{S2}} + 0.2\text{ V}$ )	$I_{\text{LEAK}}$	-	-	10	$\mu\text{A}$
Current Limitation Flag Threshold ( $5.5\text{ V} < V_{\text{SUP}} < 27\text{ V}$ )	$V_{\text{THSC}}$	$V_{\text{SUP}} - 2$	-	-	V

**Table 17. Static Electrical Characteristics - Low-side Drivers - LS**

Ratings	Symbol	Min	Typ	Max	Unit
Output Drain-to-Source On resistance $T_{\text{J}} = 25\text{ }^{\circ}\text{C}$ , $I_{\text{LOAD}} = 150\text{ mA}$ , $V_{\text{SUP}} > 9.0\text{ V}$ $T_{\text{J}} = 150\text{ }^{\circ}\text{C}$ , $I_{\text{LOAD}} = 150\text{ mA}$ , $V_{\text{SUP}} > 9.0\text{ V}$ $T_{\text{J}} = 150\text{ }^{\circ}\text{C}$ , $I_{\text{LOAD}} = 120\text{ mA}$ , $5.5\text{ V} < V_{\text{SUP}} < 9.0\text{ V}$	$R_{\text{DS(ON)}}$	-	-	2.5 4.5 10	$\Omega$
Output Current Limitation ( $2.0\text{ V} < V_{\text{OUT}} < V_{\text{SUP}}$ )	$I_{\text{LIMLSX}}$	180	275	380	mA
Open Load Current Detection	$I_{\text{OLLSX}}$	-	8.0	12	mA
Leakage Current ( $-0.2\text{ V} < V_{\text{OUT}} < V_{\text{S1}}$ )	$I_{\text{LEAK}}$	-	-	10	$\mu\text{A}$
Active Output Energy Clamp ( $I_{\text{OUT}} = 150\text{ mA}$ )	$V_{\text{CLAMP}}$	40	-	45	V
Coil Series Resistance ( $I_{\text{OUT}} = 150\text{ mA}$ )	$R_{\text{COIL}}$	120	-	-	$\Omega$
Coil Inductance ( $I_{\text{OUT}} = 150\text{ mA}$ )	$R_{\text{COIL}}$	-	-	400	mH
Current Limitation Flag Threshold ( $5.5\text{ V} < V_{\text{SUP}} < 27\text{ V}$ )	$V_{\text{THSC}}$	2.0	-	-	V

**Table 18. Static Electrical Characteristics - LIN Physical Layer Interface - LIN**

Ratings	Symbol	Min	Typ	Max	Unit
Current Limitation for Driver dominant state. $V_{\text{BUS}} = 18\text{ V}$	$I_{\text{BUSLIM}}$	40	120	200	mA
Input Leakage Current at the Receiver incl. Pull-up Resistor RSLAVE; Driver OFF; $V_{\text{BUS}} = 0\text{ V}$ ; $V_{\text{BAT}} = 12\text{ V}$	$I_{\text{BUS\_PAS\_DOM}}$	-1.0	-	-	mA
Input Leakage Current at the Receiver incl. Pull-up Resistor RSLAVE; Driver OFF; $8.0\text{ V} < V_{\text{BAT}} < 18\text{ V}$ ; $8.0\text{ V} < V_{\text{BUS}} < 18\text{ V}$ ; $V_{\text{BUS}} \geq V_{\text{BAT}}$	$I_{\text{BUS\_PAS\_REC}}$	-	-	20	$\mu\text{A}$

**Table 18. Static Electrical Characteristics - LIN Physical Layer Interface - LIN (continued)**

Ratings	Symbol	Min	Typ	Max	Unit
Input Leakage Current; GND Disconnected; GNDDEVICE = VSUP; 0 < VBUS < 18 V; VBAT = 12 V	I <sub>BUS_NO_GND</sub>	-1.0	-	1.0	mA
Input Leakage Current; VBAT disconnected; VSUP_DEVICE = GND; 0 < VBUS < 18 V	I <sub>BUS_NO_BAT</sub>	-	-	100	μA
Receiver Input Voltage; Receiver Dominant State	V <sub>BUSDOM</sub>	-	-	0.4	V <sub>SUP</sub>
Receiver Input Voltage; Receiver Recessive State	V <sub>BUSREC</sub>	0.6	-	-	V <sub>SUP</sub>
Receiver Threshold Center (V <sub>TH_DOM</sub> + V <sub>TH_REC</sub> )/2	V <sub>BUS_CNT</sub>	0.475	0.5	0.525	V <sub>SUP</sub>
Receiver Threshold Hysteresis (V <sub>TH_REC</sub> - V <sub>TH_DOM</sub> )	V <sub>BUS_HYS</sub>	-	-	0.175	V <sub>SUP</sub>
Voltage Drop at the serial Diode	D <sub>SER_INT</sub>	0.4	0.7	1.0	V
LIN Pull-up Resistor	R <sub>SLAVE</sub>	20	30	60	kΩ
Bus Wake-up Threshold from Stop or Sleep <sup>(22)</sup>	V <sub>WUP</sub>	4.5	5.0	6.0	V
Bus Dominant Voltage	V <sub>DOM</sub>	-	-	2.5	V

Note:  
22. Considering drop from VBAT to LIN, at very low VBAT level, the internal logic detects a dominant as the threshold does not decrease with VSUP.

**Table 19. Static Electrical Characteristics - High Voltage Inputs - Lx**

Ratings	Symbol	Min	Typ	Max	Unit
Low Detection Threshold 7.0 V ≤ V <sub>SUP</sub> ≤ 27 V 5.5 V ≤ V <sub>SUP</sub> ≤ 7 V	V <sub>THL</sub>	2.2 1.5	2.5 2.5	3.4 4.0	V
High Detection Threshold 7.0 V ≤ V <sub>SUP</sub> ≤ 27 V 5.5 V ≤ V <sub>SUP</sub> ≤ 7 V	V <sub>THH</sub>	2.6 2.0	3.0 3.0	3.7 4.5	V
Hysteresis 5.5 V ≤ V <sub>SUP</sub> ≤ 27 V	V <sub>HYS</sub>	0.25	0.45	1.0	V
Input Current Lx (-0.2 V < V <sub>IN</sub> < VS1)	I <sub>IN</sub>	-10	-	10	μA
Analog Input Impedance Lx	R <sub>LxIN</sub>	-	-	1.2	MΩ
Lx Series Resistor	R <sub>Lx</sub>	9.5	10	10.5	kΩ
Lx Capacitor (optional) <sup>(23)</sup>	C <sub>Lx</sub>	-	100	-	nF
Analog Input Divider Ratio (RATIO <sub>Lx</sub> = V <sub>Lx</sub> / V <sub>ADOUT0</sub> ) LXDS (Lx Divider Select) = 0 LXDS (Lx Divider Select) = 1	RATIO <sub>Lx</sub>	- -	2.0 7.2	- -	
Analog Input Divider Ratio Accuracy	RATIO <sub>Lx</sub>	-5.5	-	5.5	%
Analog Inputs Channel Ratio - Mismatch LXDS (Lx Divider Select) = 0 LXDS (Lx Divider Select) = 1	LxMATCH	- -	- -	5.0 5.0	%

Note:  
23. The ESD behavior specified in Section 3.8, "ESD Protection and Latch-up Immunity" are guaranteed without the optional capacitor.

**Table 20. Static Electrical Characteristics - General Purpose I/O - PTB[0...2]**

Ratings	Symbol	Min	Typ	Max	Unit
Input high voltage	V <sub>IH</sub>	0.7V <sub>DDX</sub>	-	V <sub>DDX</sub> +0.3	V
Input low voltage	V <sub>IL</sub>	V <sub>SS</sub> -0.3	-	0.35V <sub>DDX</sub>	V
Input hysteresis	V <sub>HYS</sub>	-	140	-	mV
Input high voltage (VS1 = 3.7 V)	V <sub>IH3.7</sub>	2.1	-	V <sub>DDX</sub> +0.3	V

**Table 20. Static Electrical Characteristics - General Purpose I/O - PTB[0...2] (continued)**

Ratings	Symbol	Min	Typ	Max	Unit
Input low voltage (VS1 = 3.7 V)	$V_{IL3.7}$	$V_{SS}-0.3$	-	1.4	V
Input hysteresis (VS1 = 3.7 V)	$V_{HYS3.7}$	100	200	300	mV
Input leakage current (pins in high-impedance input mode) ( $V_{IN} = V_{DDX}$ or $V_{SSX}$ )	$I_{IN}$	-1.0	-	1.0	$\mu$ A
Output high voltage (pins in output mode) Full drive $I_{OH} = -10$ mA	$V_{OH}$	$V_{DDX}-0.8$	-	-	V
Output low voltage (pins in output mode) Full drive $I_{OL} = +10$ mA	$V_{OL}$	-	-	0.8	V
Internal pull-up resistance ( $V_{IH}$ min > Input voltage > $V_{IL}$ max)	$R_{PUL}$	26.25	37.5	48.75	k $\Omega$
Input capacitance	$C_{IN}$	-	6.0	-	pF
Clamp Voltage when selected as analog input	$V_{CL\_AIN}$	VDD	-	-	V
Analog Input impedance = 10 k $\Omega$ max, Capacitance = 12 pF	$R_{AIN}$	-	-	10	k $\Omega$
Analog Input Capacitance = 12 pF	$C_{AIN}$	-	12	-	pF
Maximum current all PTB combined (VDDX capability)	$I_{BMAX}$	-15	-	15	mA
Output Drive strength at 10 MHz	$C_{OUT}$	-	-	100	pF

**Table 21. Static Electrical Characteristics - Analog Digital Converter - ADC<sup>(24)</sup>**

Ratings	Symbol	Min	Typ	Max	Unit
ADC2p5 Reference Voltage 5.5 V < $V_{SUP}$ < 27 V	$V_{ADC2p5RUN}$	2.45	2.5	2.55	V
ADC2p5 Reference Stop Mode Output Voltage	$V_{ADC2p5STOP}$	-	-	100	mV
Line Regulation, Normal Mode	$LR_{RUNA}$	-	10	12.5	mV
External Capacitor	$C_{ADC2p5}$	0.1	-	1.0	$\mu$ F
External Capacitor ESR	$C_{VDD\_R}$	-	-	10	W
Scale Factor Error	$E_{SCALE}$	-1	-	1	LSB
Differential Linearity Error	$E_{DNL}$	-1.5	-	1.5	LSB
Integral Linearity Error	$E_{INL}$	-1.5	-	1.5	LSB
Zero Offset Error	$E_{OFF}$	-2.0	-	2.0	LSB
Quantization Error	$E_Q$	-0.5	-	0.5	LSB
Total Error with offset compensation	TE	-5.0	-	5.0	LSB
Bandgap measurement Channel (CH14) Valid Result Range (including $\pm 7.0\%$ bg1p25 sleep accuracy + high-impedance measurement error of $\pm 5.0\%$ at $f_{ADC}$ ) <sup>(25)</sup>	$AD_{CH14}$	1.1	1.25	1.4	V

Note:

24. No external load allowed on the ADC2p5 pin.  
 25. Reduced ADC frequency lowers measurement error.

**Table 22. Static Electrical Characteristics - Current Sense Module - ISENSE**

Ratings	Symbol	Min	Typ	Max	Unit
Gain	G				
CSGS (Current Sense Gain Select) = 000		-	7.0	-	
CSGS (Current Sense Gain Select) = 001		-	9.0	-	
CSGS (Current Sense Gain Select) = 010		-	10	-	
CSGS (Current Sense Gain Select) = 011		-	12	-	
CSGS (Current Sense Gain Select) = 100		-	14	-	
CSGS (Current Sense Gain Select) = 101		-	18	-	
CSGS (Current Sense Gain Select) = 110		-	24	-	
CSGS (Current Sense Gain Select) = 111		-	36	-	
Gain Accuracy		-3.0	-	3.0	%
Offset		-1.5	-	1.5	%
Resolution <sup>(26)</sup>	RES	-	51	-	mA/LSB
ISENSEH, ISENSEL Input Common Mode Voltage Range	V <sub>IN</sub>	-0.2	-	3.0	V
Current Sense Module - Normal Mode Current Consumption Adder (CSE = 1)	I <sub>ISENSE</sub>	-	600	-	μA

Note:

26. RES = 2.44 mV/(GAIN\*R<sub>SHUNT</sub>)

**Table 23. Static Electrical Characteristics - Temperature Sensor - TSENSE**

Ratings	Symbol	Min	Typ	Max	Unit
Internal Chip Temperature Sense Gain <sup>(27)</sup>	TS <sub>G</sub>	-	9.17	-	mV/k
Internal Chip Temperature Sense Error at the end of conversion <sup>(27)</sup>	TS <sub>ERR</sub>	-5.0	-	5.0	°C
Temperature represented by a ADC <sub>IN</sub> Voltage of 0.150 V <sup>(27)</sup>	T <sub>0.15V</sub>	-55	-50	-45	°C
Temperature represented by a ADC <sub>IN</sub> Voltage of 1.984 V <sup>(27)</sup>	T <sub>1.984V</sub>	145	150	155	°C

Note:

27. Guaranteed by design and characterization.

**Table 24. Static Electrical Characteristics - Supply Voltage Sense - VSENSE and VS1SENSE**

Ratings	Symbol	Min	Typ	Max	Unit
VSENSE Input Divider Ratio (RATIO <sub>VSENSE</sub> = V <sub>VSENSE</sub> / ADC <sub>IN</sub> ) 5.5 V < V <sub>SUP</sub> < 27 V	RATIO <sub>VSENSE</sub>		10.8		
VSENSE error - whole path (VSENSE pin to Digital value)	ER <sub>VSENSE</sub>	-	-	5.0	%
VS1SENSE Input Divider Ratio (RATIO <sub>VS1SENSE</sub> = V <sub>VS1SENSE</sub> / ADC <sub>IN</sub> ) 5.5 V < V <sub>SUP</sub> < 27 V	RATIO <sub>VS1SENSE</sub>		10.8		
VS1SENSE error - whole path (VS1 pin to Digital value)	ER <sub>VS1SENSE</sub>	-	-	5.0	%
VSENSE Series Resistor	R <sub>VSENSE</sub>	9.5	10	10.5	kΩ
VSENSE Capacitor (optional) <sup>(28)</sup>	C <sub>VSENSE</sub>	-	100	-	nF

Note:

28. The ESD behavior specified in Section 3.8, "ESD Protection and Latch-up Immunity" is guaranteed without the optional capacitor.

### 3.5.2 Static Electrical Characteristics MCU Die

#### 3.5.2.1 I/O Characteristics

This section describes the characteristics of all I/O pins except EXTAL, XTAL, TEST and supply pins.

**Table 25. 5.0 V I/O Characteristics for PTA,  $\overline{\text{RESET}}$  and BKGD Pins**

Ratings	Symbol	Min	Typ	Max	Unit
Input high voltage	$V_{IH}$	$0.65 \cdot V_{DD}$	-	-	V
Input high voltage	$V_{IH}$	-	-	$V_{DD} + 0.3$	V
Input low voltage	$V_{IL}$	-	-	$0.35 \cdot V_{DD}$	V
Input low voltage	$V_{IL}$	$V_{SS} - 0.3$	-	-	V
Input hysteresis	$V_{HYS}$	-	250	-	mV
Input leakage current (pins in high-impedance input mode) $V_{in} = V_{DDX}$ or $V_{SSX}$	$I_{IN}$	-1.0	-	1.0	$\mu\text{A}$
Output high voltage (pins in output mode) Partial Drive $I_{OH} = -2.0$ mA	$V_{OH}$	$V_{DD} - 0.8$	-	-	V
Output high voltage (pins in output mode) Full Drive $I_{OH} = -10$ mA	$V_{OH}$	$V_{DD} - 0.8$	-	-	V
Output low voltage (pins in output mode) Partial drive $I_{OL} = +2.0$ mA	$V_{OL}$	-	-	0.8	V
Output low voltage (pins in output mode) Full Drive $I_{OL} = +10$ mA	$V_{OL}$	-	-	0.8	V
Internal pull-up resistance ( $V_{IHmin} >$ input voltage $> V_{ILmax}$ )	$R_{PUL}$	25	-	50	$k\Omega$
Internal pull-down resistance ( $V_{IHmin} >$ input voltage $> V_{ILmax}$ )	$R_{PDH}$	25	-	50	$k\Omega$
Input capacitance	$C_{in}$	-	6.0	-	pF
Injection current <sup>(29)</sup>					
Single pin limit	$I_{ICS}$	-2.5	-	2.5	mA
Total device Limit, sum of all injected currents	$I_{ICP}$	-25	-	25	

Note:

29. Refer to Section 3.8, "ESD Protection and Latch-up Immunity" for more details.

### 3.6 Dynamic Electrical Characteristics

Dynamic electrical characteristics noted under conditions  $5.5\text{V} \leq V_{SUP} \leq 18\text{V}$ ,  $-40\text{ }^\circ\text{C} \leq T_A \leq 105\text{ }^\circ\text{C}$ , unless otherwise noted. Typical values noted reflect the approximate parameter mean at  $T_A = 25\text{ }^\circ\text{C}$  under nominal conditions unless otherwise noted.

#### 3.6.1 Dynamic Electrical Characteristics Analog Die

**Table 26. Dynamic Electrical Characteristics - Modes of Operation**

Ratings	Symbol	Min	Typ	Max	Unit
VDD Short Timeout	$t_{VTO}$	110	150	205	ms
Analog Base Clock	$f_{BASE}$	-	100	-	kHz
Reset Delay	$t_{RST}$	140	200	280	$\mu\text{s}$

**Table 27. Dynamic Electrical Characteristics - Power Supply**

Ratings	Symbol	Min	Typ	Max	Unit
Glitch Filter Low Battery Warning (LBI) <sup>(30)</sup>	$t_{LB}$	-	2.0	-	$\mu\text{s}$
Glitch Filter Low Voltage Warning (LVI) <sup>(30)</sup>	$t_{LV}$	-	2.0	-	$\mu\text{s}$

**Table 27. Dynamic Electrical Characteristics - Power Supply (continued)**

Ratings	Symbol	Min	Typ	Max	Unit
Glitch Filter High Voltage Warning (HVI) <sup>(30)</sup>	$t_{HV}$	-	2.0	-	$\mu\text{s}$

Note:

30. Guaranteed by design.

**Table 28. Dynamic Electrical Characteristics - Die to Die Interface - D2D**

Ratings	Symbol	Min	Typ	Max	Unit
Operating Frequency (D2DCLK, D2D[0:3])	$f_{D2D}$	$f_{ADC(MIN)}$	-	$f_{BUSMAX}$ <sup>(31)</sup>	MHz

Note:

31.  $f_{BUSMAX}$  frequency ratings differ by device and is specified in [Table 1](#)

**Table 29. Dynamic Electrical Characteristics - Resets**

Ratings	Symbol	Min	Typ	Max	Unit
Reset Deglitch Filter Time	$t_{RSTDF}$	1.2	2.0	3.0	$\mu\text{s}$
Reset Low Level Duration	$t_{RSTLOW}$	140	200	280	$\mu\text{s}$

**Table 30. Dynamic Electrical Characteristics - Wake-up / Cyclic Sense**

Ratings	Symbol	Min	Typ	Max	Unit
Lx Wake-up Filter Time	$t_{WUF}$	-	20		$\mu\text{s}$
Cyclic Sense / Forced Wake-up Timing Accuracy - not trimmed	$CS_{AC}$	-35	-	35	%
Cyclic Sense / Forced Wake-up Timing Accuracy - trimmed <sup>(32)</sup>	$CS_{ACT}$	-5.0	-	5.0	%
Time between HSx on and Lx sense during cyclic sense	$t_s$	same as $t_{HSON}$ / $t_{HSOINT}$			-
HSx ON duration during Cyclic Sense	$t_{HSON}$	140	200	280	$\mu\text{s}$
HSx ON duration during Cyclic Sense - trimmed <sup>(32)</sup>	$t_{HSOINT}$	180	200	220	$\mu\text{s}$

Note:

32. Trimming parameters are not available in Sleep mode.

**Table 31. Dynamic Electrical Characteristics - Window Watchdog**

Ratings	Symbol	Min	Typ	Max	Unit
Initial Non-window Watchdog Timeout	$t_{WDTO}$	110	150	190	ms
Watchdog Timeout Accuracy - not trimmed	$WD_{AC}$	-35	-	35	%
Watchdog Timeout Accuracy - trimmed	$WD_{ACT}$	-5.0	-	5.0	%

**Table 32. Dynamic Electrical Characteristics - High-side Drivers - HS**

Ratings	Symbol	Min	Typ	Max	Unit
High-side Operating Frequency <sup>(33)</sup> , Load Condition: $C_{LOAD} \leq 2.2 \text{ nF}$ ; $R_{LOAD} \geq 500 \Omega$	$f_{HS}$	-	-	50	kHz

Note:

33. Guaranteed by design.

**Table 33. Dynamic Electrical Characteristics - Low-side Drivers - LS**

Ratings	Symbol	Min	Typ	Max	Unit
Low-side Operating Frequency <sup>(34)</sup> , Load Condition: $C_{LOAD} \leq 2.2 \text{ nF}$ ; $R_{LOAD} \geq 500 \Omega$	$f_{HS}$	-	-	50	kHz

Note:

34. Guaranteed by design.

**Table 34. Dynamic Electrical Characteristics - LIN Physical Layer Interface - LIN**

Ratings	Symbol	Min	Typ	Max	Unit
Bus Wake-up Deglitcher (Sleep and Stop Mode)	$t_{PROPWL}$	60	80	100	$\mu\text{s}$
Fast Bit Rate (Programming Mode)	BR <sub>FAST</sub>	-	-	100	kBit/s
Propagation Delay of Receiver, $t_{REC\_PD} = \text{MAX}(t_{REC\_PDR}, t_{REC\_PDF})$ <sup>(35)</sup>	$t_{REC\_PD}$	-	-	6.0	$\mu\text{s}$
Symmetry of Receiver Propagation Delay, $t_{REC\_PDF} - t_{REC\_PDR}$	$t_{REC\_SYM}$	-2.0	-	2.0	$\mu\text{s}$
LIN Driver - 20.0 kBit/s; Bus load conditions ( $C_{BUS}$ ; $R_{BUS}$ ): 1.0 nF; 1.0 k $\Omega$ / 6,8 nF; 660 $\Omega$ / 10 nF; 500 $\Omega$ . Measurement thresholds: 50% of TXD signal to LIN signal threshold defined at each parameter. See Figure 5 and Figure 6.					
Duty Cycle 1: $TH_{REC(MAX)} = 0.744 \times V_{SUP}$ , $TH_{DOM(MAX)} = 0.581 \times V_{SUP}$ , $7.0 \text{ V} \leq V_{SUP} \leq 18 \text{ V}$ ; $t_{BIT} = 50 \mu\text{s}$ ; $D1 = t_{BUS\_REC(MIN)} / (2 \times t_{BIT})$	D1	0.396	-	-	
Duty Cycle 2: $TH_{REC(MIN)} = 0.422 \times V_{SUP}$ , $TH_{DOM(MIN)} = 0.284 \times V_{SUP}$ , $7.6 \text{ V} \leq V_{SUP} \leq 18 \text{ V}$ ; $t_{BIT} = 50 \mu\text{s}$ , $D2 = t_{BUS\_REC(MAX)} / (2 \times t_{BIT})$	D2	-	-	0.581	
LIN Driver - 10.0 kBit/s; Bus load conditions ( $C_{BUS}$ ; $R_{BUS}$ ): 1.0 nF; 1.0 k $\Omega$ / 6,8 nF; 660 $\Omega$ / 10 nF; 500 $\Omega$ . Measurement thresholds: 50% of TXD signal to LIN signal threshold defined at each parameter. See Figure 5 and Figure 7.					
Duty Cycle 3: $TH_{REC(MAX)} = 0.778 \times V_{SUP}$ , $TH_{DOM(MAX)} = 0.616 \times V_{SUP}$ , $7.0 \text{ V} \leq V_{SUP} \leq 18 \text{ V}$ ; $t_{BIT} = 96 \mu\text{s}$ , $D3 = t_{BUS\_REC(MIN)} / (2 \times t_{BIT})$	D3	0.417	-	-	
Duty Cycle 4: $TH_{REC(MIN)} = 0.389 \times V_{SUP}$ , $TH_{DOM(MIN)} = 0.251 \times V_{SUP}$ , $7.6 \text{ V} \leq V_{SUP} \leq 18 \text{ V}$ ; $t_{BIT} = 96 \mu\text{s}$ , $D4 = t_{BUS\_REC(MAX)} / (2 \times t_{BIT})$	D4	-	-	0.590	
Transmitter Symmetry $t_{TRAN\_SYM} < \text{MAX}(t_{TRAN\_SYM60\%}, t_{TRAN\_SYM40\%})$ $tran\_sym60\% = t_{tran\_pdf60\%} - t_{tran\_pdr60\%}$ $tran\_sym40\% = t_{tran\_pdf40\%} - t_{tran\_pdr40\%}$	$t_{TRAN\_SYM}$	-7.25	0	7.25	$\mu\text{s}$

Note:

35.  $V_{SUP}$  from 7.0 to 18 V, bus load  $R_{BUS}$  and  $C_{BUS}$  1.0 nF / 1.0 k $\Omega$ , 6.8 nF / 660  $\Omega$ , 10 nF / 500  $\Omega$ . Measurement thresholds: 50% of TXD signal to LIN signal threshold defined at each parameter. See Figure 5 and Figure 8.
36. LIN Transmitter Timing, ( $V_{SUP}$  from 7.0 to 18 V) - See Figure 9

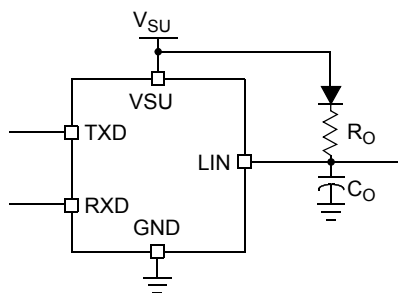
 Note:  $R_n$  and  $C_n$ : 1.0k $\Omega$ /1.0nF, 660 $\Omega$ /6.8

**Figure 5. Test Circuit for Timing Measurements**

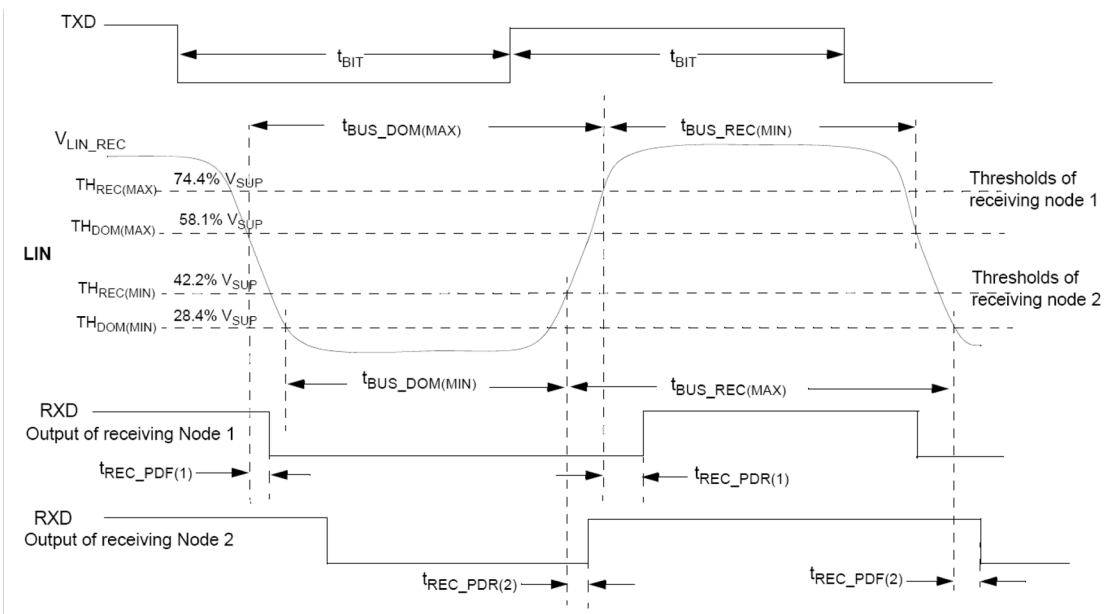

**Figure 6. LIN Timing Measurements for Normal Baud Rate**

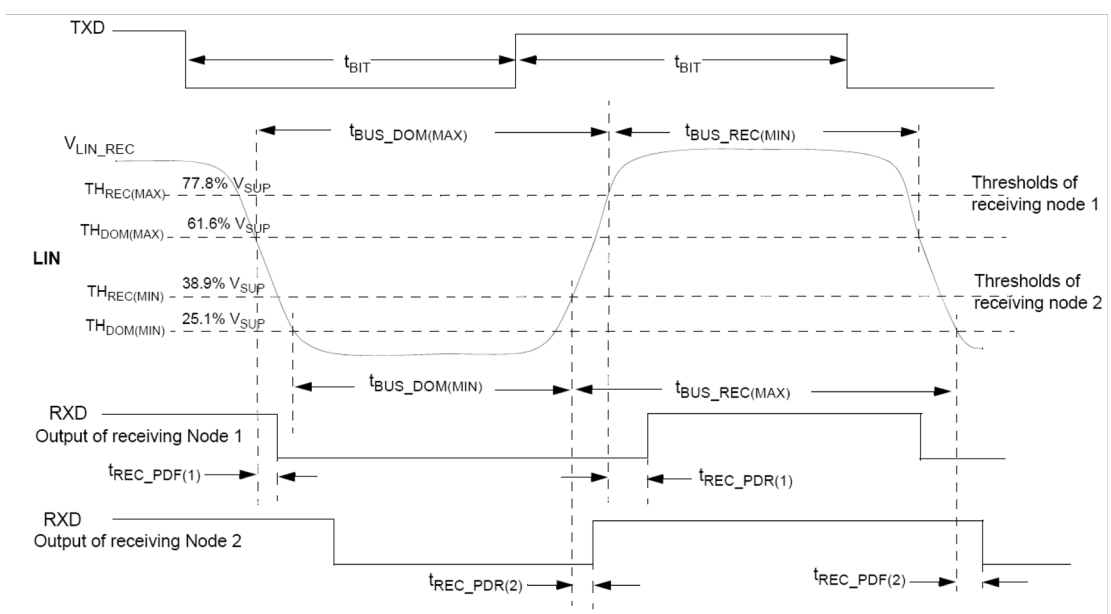

**Figure 7. LIN Timing Measurements for Slow Baud Rate**

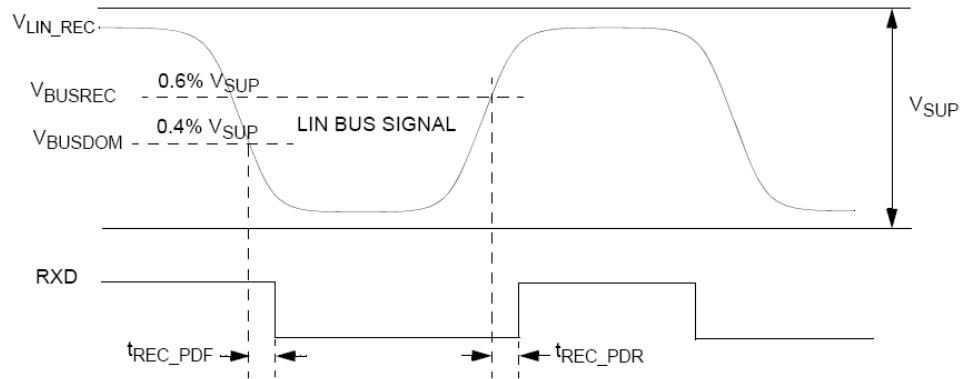

Figure 8. LIN Receiver Timing

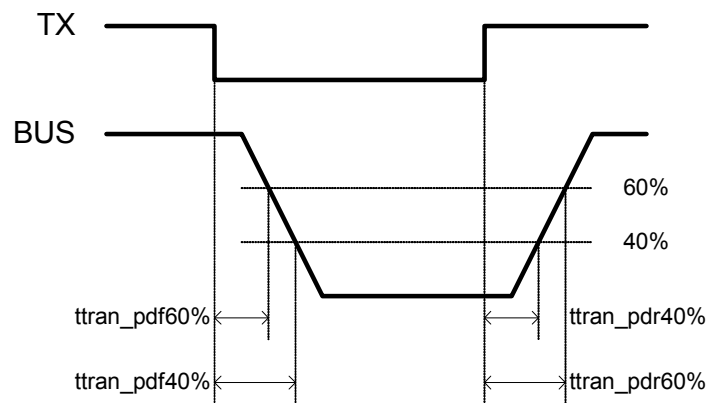

Figure 9. LIN Transmitter Timing

Table 35. Dynamic Electrical Characteristics - General Purpose I/O - PTB[0...2]

Ratings	Symbol	Min	Typ	Max	Unit
GPIO Digital Frequency <sup>(37)</sup>	$f_{PTB}$	-	-	10	MHz
Propagation Delay - Rising Edge <sup>(37), (38)</sup>	$t_{PDR}$	-	-	20	ns
Rise Time - Rising Edge <sup>(37)</sup>	$t_{RISE}$	-	-	17.5	ns
Propagation Delay - Falling Edge <sup>(37)</sup>	$t_{PDF}$	-	-	20	ns
Rise Time - Falling Edge <sup>(37)</sup>	$t_{FALL}$	-	-	17.5	ns

Note:

37. Guaranteed by design.

38. Load PTBx = 100 pF.

**Table 36. Dynamic Electrical Characteristics - Analog Digital Converter - ADC**

Ratings	Symbol	Min	Typ	Max	Unit
ADC Operating Frequency <sup>(39)</sup>	f <sub>ADC</sub>	1.6	2.0	2.4	MHz
Conversion Time (from ACCR write to CC Flag) <sup>(39)</sup>	t <sub>CONV</sub>	26			clk
Sample Frequency Channel 14 (Bandgap) <sup>(39)</sup>	f <sub>CH14</sub>	-	-	2.5	kHz

Note:

39. Guaranteed by design.

## 3.6.2 Dynamic Electrical Characteristics MCU Die

### 3.6.2.1 NVM Timing

The time base for all NVM program or erase operations is derived from the bus block. A minimum bus frequency f<sub>NVMBUS</sub> is required for performing program or erase operations. The NVM module do not has any means to monitor the frequency and does not prevent a program or erase operation at frequencies above or below the specified minimum. Attempting to program or erase the NVM modules at a lower frequency, a full program, or erase transition is not assured.

The Flash program and erase operations are timed using a clock derived from the bus clock using the FCLKDIV and register. The frequency of this clock must be set within the limits specified as f<sub>NVMOP</sub>.

The minimum program and erase times shown in [Table 37](#) are calculated for maximum f<sub>NVMOP</sub> and maximum f<sub>BUS</sub>. The maximum times are calculated for minimum f<sub>NVMOP</sub> and a f<sub>BUS</sub> of 2.0 MHz.

#### 3.6.2.1.1 Single Word Programming

The programming time for single word programming is dependant on the bus frequency as a well as on the frequency f<sub>NVMOP</sub>, and can be calculated according to the following formula.

$$t_{\text{swpgm}} = 9 \cdot \frac{1}{f_{\text{NVMOP}}} + 25 \cdot \frac{1}{f_{\text{bus}}}$$

#### 3.6.2.1.2 Burst Programming

This applies only to the Flash, where up to 64 words in a row can be programmed consecutively, using burst programming by keeping the command pipeline filled. The time to program a consecutive word can be calculated as:

$$t_{\text{bwpgm}} = 4 \cdot \frac{1}{f_{\text{NVMOP}}} + 9 \cdot \frac{1}{f_{\text{bus}}}$$

The time to program a whole row is:

$$t_{\text{brpgm}} = t_{\text{swpgm}} + 63 \cdot t_{\text{bwpgm}}$$

Burst programming is more than 2 times faster than single word programming.

#### 3.6.2.1.3 Sector Erase

##### NOTE

The sector erase cycle is divided into 16 individual erase pulses to achieve faster system response during the erase flow. The given erase time (t<sub>ERA</sub>) specifies the time considering consecutive pulses.

Erasing a 512-byte Flash sector takes:

$$t_{\text{era}} \approx 4000 \cdot \frac{1}{f_{\text{NVMOP}}}$$

The setup time can be ignored for this operation.

### 3.6.2.1.4 Mass Erase

Erasing a NVM block takes:

$$t_{\text{mass}} \approx 20000 \cdot \frac{1}{f_{\text{NVMOP}}}$$

The setup time can be ignored for this operation.

### 3.6.2.1.5 Blank Check

The time it takes to perform a blank check on the Flash is dependant on the location of the first non-blank word, starting at relative address zero. It takes one bus cycle per word to verify plus a setup of the command.

$$t_{\text{check}} \approx \text{location} \cdot t_{\text{cyc}} + 10 \cdot t_{\text{cyc}}$$

**Table 37. NVM Timing Characteristics**

Rating	Symbol	Min	Typ	Max	Unit
Bus frequency for programming or erase operations	$f_{\text{NVMBUS}}$	1.0	-	-	MHz
Operating frequency	$f_{\text{NVMOP}}$	150	-	200	kHz
Single word programming time	$t_{\text{SWPGM}}$	46 <sup>(40)</sup>	-	74.5 <sup>(40)</sup>	$\mu\text{s}$
Flash burst programming consecutive word	$t_{\text{BWPGM}}$	20.4 <sup>(40)</sup>	-	31 <sup>(41)</sup>	$\mu\text{s}$
Flash burst programming time for 64 words <sup>(43)</sup>	$t_{\text{BRPGM}}$	1331.2 <sup>(40)</sup>	-	2027.5 <sup>(41)</sup>	$\mu\text{s}$
Sector erase time <sup>(41)</sup>	$t_{\text{ERA}}$	20 <sup>(42)</sup>	-	26.7 <sup>(41)</sup>	ms
Mass erase time	$t_{\text{MASS}}$	100 <sup>(44)</sup>	-	133 <sup>(41)</sup>	ms
Blank check time Flash per block	$t_{\text{CHECK}}$	11 <sup>(43)</sup>	-	65546 <sup>(44)</sup>	$t_{\text{CYC}}$

Note:

40. Minimum programming times are achieved under maximum NVM operating frequency  $f_{\text{NVMOP}}$  and maximum bus frequency  $f_{\text{BUS}}$ .
41. The sector erase cycle is divided into 16 individual erase pulses to achieve faster system response during the erase flow. The given erase time ( $t_{\text{ERA}}$ ) specifies the time considering consecutive pulses.
42. Minimum erase times are achieved under maximum NVM operating frequency,  $f_{\text{NVMOP}}$ .
43. Minimum time, if first word in the array is not blank.
44. Maximum time to complete check on an erased block.

**3.6.2.2 NVM Reliability**

The reliability of the NVM blocks is guaranteed by stress tests during qualification, constant process monitors, and burn-in to screen early life failures. The program/erase cycle count on the sector is incremented every time a sector or mass erase event is executed.

**Table 38. NVM Reliability Characteristics**

Rating	Symbol	Min	Typ	Max	Unit
Data retention after 10,000 program/erase cycles for $T_{JAVG} \leq 85\text{ }^{\circ}\text{C}$ <sup>(45), (46)</sup>	$t_{FLRET}$	15	100 <sup>(47)</sup>	-	Years
Data retention with <100 program/erase cycles for $T_{JAVG} \leq 85\text{ }^{\circ}\text{C}$ <sup>(45), (46)</sup>		20	100 <sup>(47)</sup>	-	
Number of program/erase cycles <sup>(46)</sup> ( $-40\text{ }^{\circ}\text{C} \leq T_J \leq 0\text{ }^{\circ}\text{C}$ )	$n_{FL}$	10,000	-	-	Cycles
Number of program/erase cycles <sup>(46)</sup> ( $0\text{ }^{\circ}\text{C} \leq T_J \leq 140\text{ }^{\circ}\text{C}$ )		10,000	100,000 <sup>(48)</sup>	-	

- Note:
- 45.  $T_{JAVG}$  is the Average Junction Temperature
  - 46.  $T_{JAVG}$  does not exceed 85 °C considering a typical temperature profile over the lifetime of a consumer, industrial, or automotive application.
  - 47. Typical data retention values are based on intrinsic capability of the technology measured at high temperature and de-rated to 25 °C, using the Arrhenius equation. For additional information on how Freescale defines Typical Data Retention, refer to Engineering Bulletin EB618.
  - 48. Spec table quotes typical endurance evaluated at 25 °C for this product family, typical endurance at various temperature can be estimated using the graph in Figure 10. For additional information on how Freescale defines Typical Endurance, refer to Engineering Bulletin EB619.

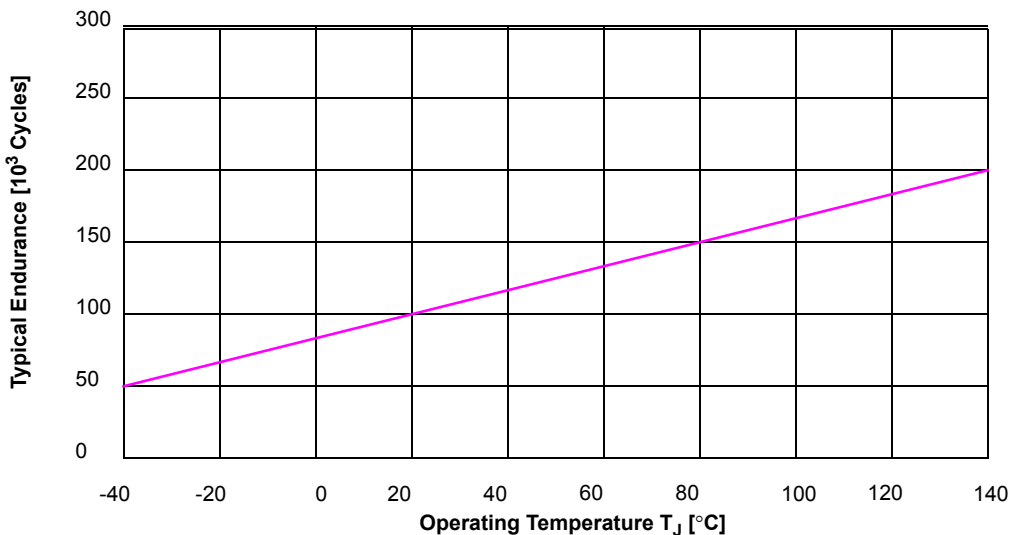

**Figure 10. Typical Flash Cycling Endurance vs. Temperature**

### 3.6.2.3 Reset, Oscillator and Internal Clock Generation

#### 3.6.2.3.1 Startup & FLL Characteristics

Table 39 summarizes several startup characteristics explained in this section. Detailed description of the startup behavior can be found in the Clock and Reset Generator (CRG) block description.

**Table 39. Startup & FLL Characteristics**

Rating	Symbol	Min	Typ	Max	Unit
Internal Reference Frequency <sup>(49)</sup> (-40 °C ≤ T <sub>J</sub> ≤ 105 °C)	f <sub>IREF_TRIM</sub>	31.36	32	32.64	kHz
Internal Reference Frequency <sup>(49)</sup> (-40 °C ≤ T <sub>J</sub> ≤ 140 °C)	f <sub>IREF_TRIM</sub>	30.40	32	33.60	kHz
Allowed frequency range for FLL Reference Clock	f <sub>FLLREF</sub>	25.52	-	40	kHz
DCO Frequency locking range	f <sub>DCO</sub>	32	-	40	MHz
DCO minimum frequency	f <sub>DCO_MIN</sub>	18	-	29	MHz
DCO stabilization delay in frequency locked loop	t <sub>STAB</sub>	-	0.3	-	ms
Lock Detection	Δ <sub>LOCK</sub>	0	-	1.5	% <sup>(50)</sup>
Un-lock Detection	Δ <sub>UNLOCK</sub>	0.5	-	2.5	% <sup>(50)</sup>
DCO quantization error	Δt <sub>DCO</sub> <sup>(51)</sup>	-	-	0.2	%t <sub>DCO</sub>
STOP recovery time (Internal Reference Clock trimmed to 32 kHz)	t <sub>STP_REC</sub>	-	20	-	μs
Oscillator Monitor Failure Assert Frequency	f <sub>OMFA</sub>	50	-	200	kHz
Reset input pulse width, minimum input time	PW <sub>RSTL</sub>	2.0	-	-	t <sub>DCO_MIN</sub>
Startup from Reset	n <sub>RST</sub>	772	-	773	t <sub>DCO_MIN</sub>

Note:

49. Reference Frequency is factory trimmed

50. % deviation from target frequency, target frequency is f<sub>IREF\_TRIM</sub> \* (1000 + 2\*MULT[6:0])

51. f<sub>DCO</sub> = 40 MHz, f<sub>IREF\_TRIM</sub> = 32 kHz, MULT = \$7D

#### 3.6.2.3.2 Power On Reset

The release level V<sub>PORD</sub> and the assert level V<sub>PORA</sub> are derived from the VDD supply. After releasing the POR reset, the oscillator is started.

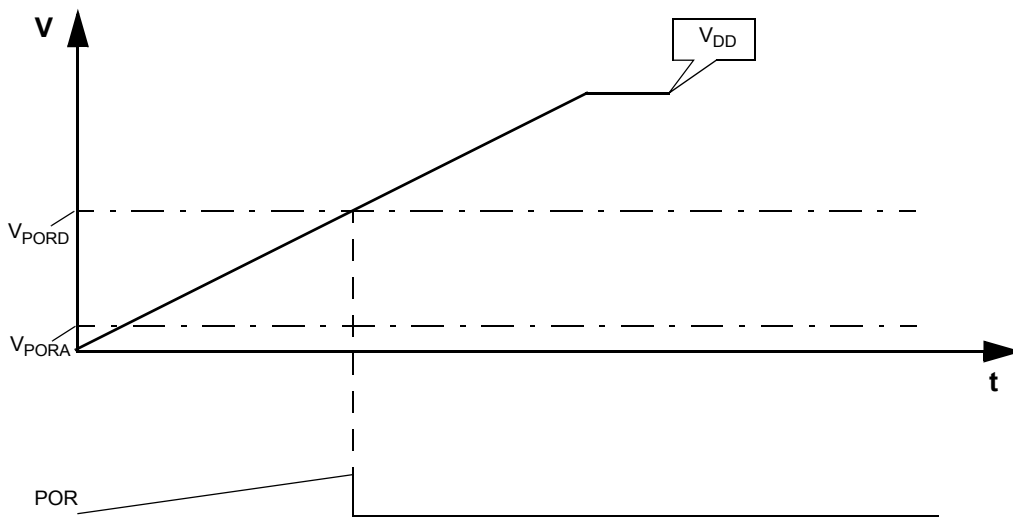

Figure 11. Power on Reset

Table 40. Power On Reset Characteristics

Rating	Symbol	Min	Typ	Max	Unit
Power On Reset assert level	$V_{PORA}$	0.84	1.51	-	V
Power On Reset de-assert level	$V_{PORD}$	-	1.51	2.01	V

### 3.6.2.3.3 Oscillator

The device features an internal full-swing Pierce oscillator configuration. The device features an oscillator monitor. An oscillator monitor failure is asserted if the frequency is below the assert frequency  $f_{CMFA}$ .

Table 41. Oscillator Characteristics

Rating	Symbol	Min	Typ	Max	Unit
Crystal oscillator range	$f_{OSC}$	4.0	-	16	MHz
Oscillator start-up time <sup>(52)</sup>	$t_{UPOSC}$	-	2.0	5.0	ms
Clock Monitor Failure Assert Frequency	$f_{CMFA}$	50	100	200	KHz
Input Capacitance (EXTAL, XTAL pins)	$C_{IN}$	-	7.0	-	pF

Note:

52.  $f_{OSC} = 4.0$  MHz,  $C = 22$  pF.

### 3.6.2.4 SPI Timing

This section provides electrical parameters and ratings for the SPI. Table 42 lists the measurement conditions.

Table 42. Measurement Conditions

Description	Value	Unit
Drive mode	Full drive mode	-
Load capacitance $C_{LOAD}$ <sup>(53)</sup> , on all outputs	50	pF
Thresholds for delay measurement points	(20% / 80%) VDDX	V

Note:

53. Timing specified for equal load on all SPI output pins. Avoid asymmetric load.

### 3.6.2.4.1 Master Mode

Figure 12 depicts the timing diagram for master mode with transmission format CPHA = 0.

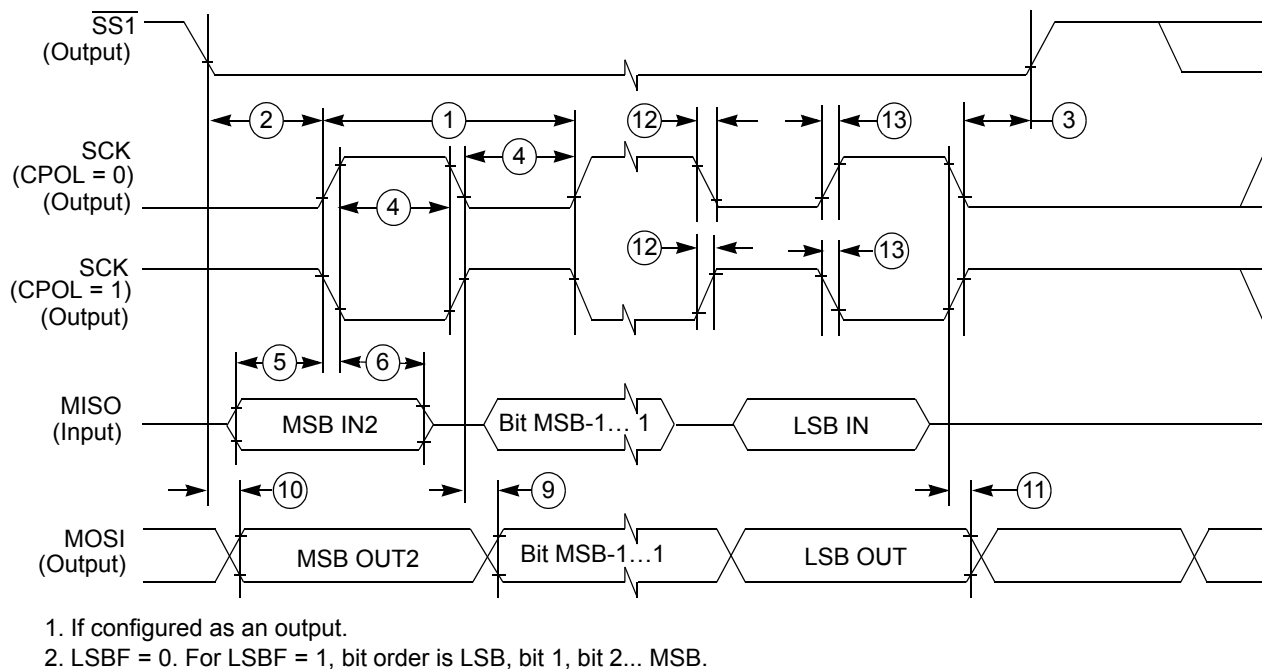

Figure 12. SPI Master Timing (CPHA = 0)

In Figure 13 depicts the timing diagram for master mode with transmission format CPHA=1.

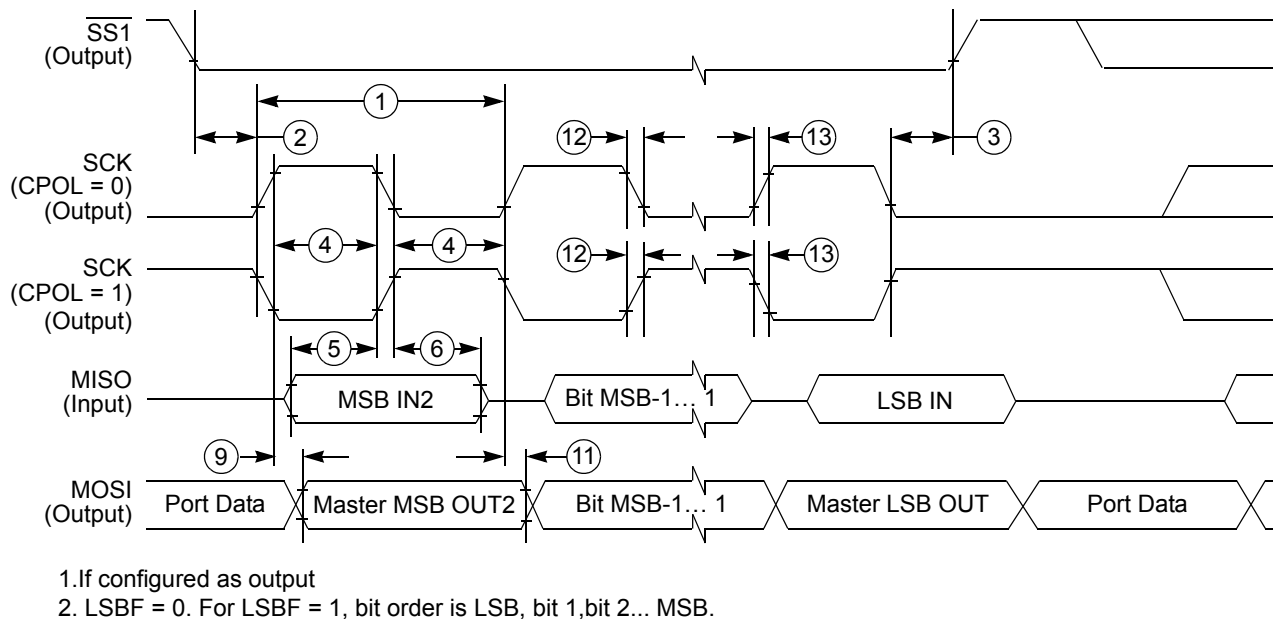

Figure 13. SPI Master Timing (CPHA = 1)

Table 43 lists the timing characteristics for master mode.

**Table 43. SPI Master Mode Timing Characteristics**

Characteristic	Symbol	Min	Typ	Max	Unit
SCK frequency	$f_{SCK}$	1/2048	-	1/2	$f_{BUS}$
SCK period	$t_{SCK}$	2.0	-	2048	$t_{BUS}$
Enable lead time	$t_{LEAD}$	-	1/2	-	$t_{SCK}$
Enable lag time	$t_{LAG}$	-	1/2	-	$t_{SCK}$
Clock (SCK) high or low time	$t_{WSCK}$	-	1/2	-	$t_{SCK}$
Data setup time (inputs)	$t_{SU}$	8.0	-	-	ns
Data hold time (inputs)	$t_{HI}$	8.0	-	-	ns
Data valid after SCK edge	$t_{VSCK}$	-	-	29	ns
Data valid after $\overline{SS}$ fall (CPHA = 0)	$t_{VSS}$	-	-	15	ns
Data hold time (outputs)	$t_{HO}$	20	-	-	ns
Rise and fall time inputs	$t_{RFI}$	-	-	8.0	ns
Rise and fall time outputs	$t_{RFO}$	-	-	8.0	ns

**3.6.2.4.2 Slave Mode**

Figure 14 depicts the timing diagram for slave mode with transmission format CPHA = 0.

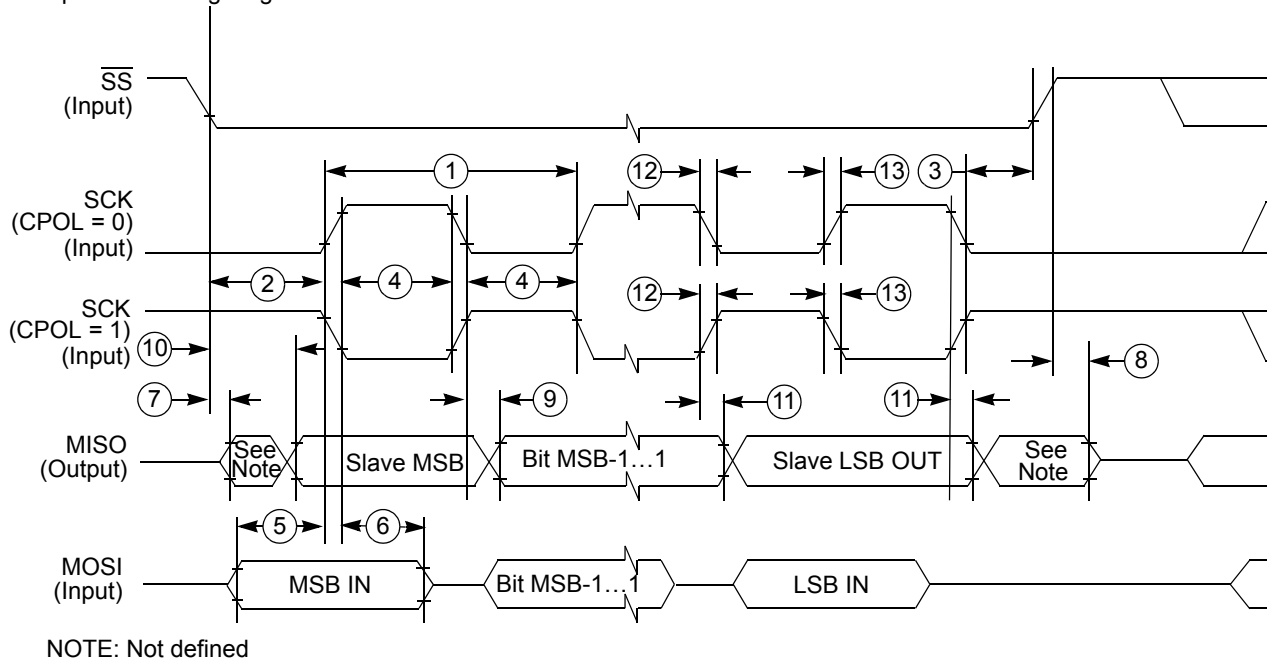

**Figure 14. SPI Slave Timing (CPHA = 0)**

Figure 15 depicts the timing diagram for slave mode with transmission format CPHA = 1.

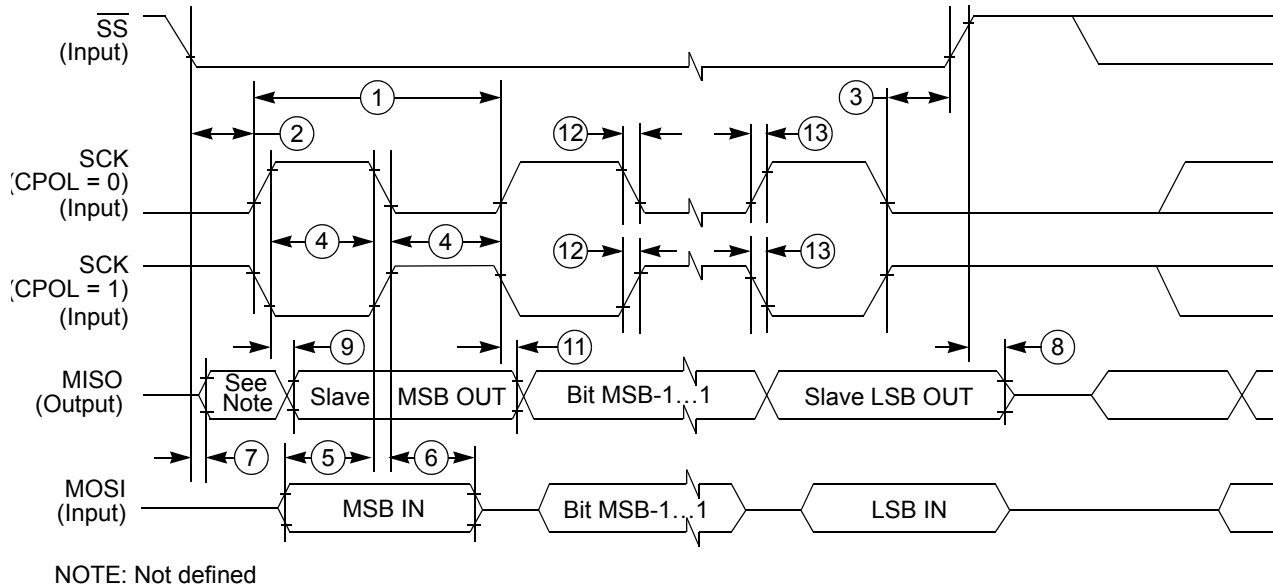

Figure 15. SPI Slave Timing (CPHA = 1)

Table 44 lists the timing characteristics for slave mode.

Table 44. SPI Slave Mode Timing Characteristics

Characteristic	Symbol	Min	Typ	Max	Unit
SCK frequency	$f_{SCK}$	DC	-	1/4	$f_{BUS}$
SCK period	$t_{SCK}$	4.0	-	$\infty$	$t_{BUS}$
Enable lead time	$t_{LEAD}$	4.0	-	-	$t_{BUS}$
Enable lag time	$t_{LAG}$	4.0	-	-	$t_{BUS}$
Clock (SCK) high or low time	$t_{WSCK}$	4.0	-	-	$t_{BUS}$
Data setup time (inputs)	$t_{SU}$	8.0	-	-	ns
Data hold time (inputs)	$t_{HI}$	8.0	-	-	ns
Slave access time (time to data active)	$t_A$	-	-	20	ns
Slave MISO disable time	$t_{DIS}$	-	-	22	ns
Data valid after SCK edge	$t_{VSCK}$	-	-	$29 + 0.5 \cdot t_{BUS}^{(53)}$	ns
Data valid after $\overline{SS}$ fall	$t_{VSS}$	-	-	$29 + 0.5 \cdot t_{BUS}^{(53)}$	ns
Data hold time (outputs)	$t_{HO}$	20	-	-	ns
Rise and fall time inputs	$t_{RFI}$	-	-	8.0	ns
Rise and fall time outputs	$t_{RFO}$	-	-	8.0	ns

Note:

 54.  $0.5 t_{BUS}$  added due to internal synchronization delay

### 3.7 Thermal Protection Characteristics

Characteristics noted under conditions  $5.5V \leq VSUP \leq 18V$ ,  $-40^\circ C \leq T_A \leq 105^\circ C$ , unless otherwise noted. Typical values noted reflect the approximate parameter mean at  $T_A = 25^\circ C$  under nominal conditions unless otherwise noted.

**Table 45. Thermal Characteristics - Voltage Regulators VDD (2.5 V) & VDDX (5.0 V)**

Ratings	Symbol	Min	Typ	Max	Unit
VDD/VDDX High-temperature Warning (HTI) <sup>(55)</sup> Threshold Hysteresis	$T_{HTI}$ $T_{HTI\_H}$	110 -	125 10	140 -	$^\circ C$
VDD/VDDX Overtemperature Shutdown <sup>(55)</sup> Threshold Hysteresis	$T_{SD}$ $T_{SD\_H}$	155 -	170 10	185 -	$^\circ C$
HSUP Overtemperature Shutdown <sup>(55)</sup>	$T_{HSUPSD}$	150	165	180	$^\circ C$
HSUP Overtemperature Shutdown Hysteresis <sup>(55)</sup>	$T_{HSUPSD\_HYS}$	-	10	-	$^\circ C$
HS Overtemperature Shutdown <sup>(55)</sup>	$T_{HSSD}$	150	165	180	$^\circ C$
HS Overtemperature Shutdown Hysteresis <sup>(55)</sup>	$T_{HSSD\_HYS}$	-	10	-	$^\circ C$
LS Overtemperature Shutdown <sup>(55)</sup>	$T_{LSSD}$	150	165	180	$^\circ C$
LS Overtemperature Shutdown Hysteresis <sup>(55)</sup>	$T_{LSSD\_HYS}$	-	10	-	$^\circ C$
LIN Overtemperature Shutdown <sup>(55)</sup>	$T_{LINS D}$	150	165	200	$^\circ C$
LIN Overtemperature Shutdown Hysteresis <sup>(55)</sup>	$T_{LINS D\_HYS}$	-	20	-	$^\circ C$

Note:

55. Guaranteed by characterization. Functionality tested.

### 3.8 ESD Protection and Latch-up Immunity

All ESD testing is in conformity with CDF-AEC-Q100 stress test qualification for automotive grade integrated circuits. During the device qualification, ESD stresses were performed for the Human Body Model (HBM), Machine Model (MM), Charge Device Model (CDM), as well as LIN transceiver specific specifications.

A device is defined as a failure if after exposure to ESD pulses, the device no longer meets the device specification. Complete DC parametric and functional testing is performed per the applicable device specification at room temperature, followed by hot temperature, unless specified otherwise in the device specification.

**Table 46. ESD and Latch-up Protection Characteristics**

Ratings	Symbol	Value	Unit
ESD - Human Body Model (HBM) following AEC-Q100 / JESD22-A114 ( $C_{ZAP} = 100\text{ pF}$ , $R_{ZAP} = 1500\ \Omega$ ) - LIN (DGND, PGND, AGND, and LGND shorted) - VS1, VS2, VSENSE, Lx - HSx - All other Pins	$V_{HBM}$	$\pm 8000$ $\pm 4000$ $\pm 3000$ $\pm 2000$	V
ESD - Charged Device Model (CDM) following AEC-Q100, Corner Pins (1, 12, 13, 24, 25, 36, 37, and 48) All other Pins	$V_{CDM}$	$\pm 750$ $\pm 500$	V
ESD - Machine Model (MM) following AEC-Q100 ( $C_{ZAP} = 200\text{ pF}$ , $R_{ZAP} = 0\ \Omega$ ), All Pins	$V_{MM}$	$\pm 200$	V
Latch-up current at $T_A = 125^\circ C$ <sup>(56)</sup>	$I_{LAT}$	$\pm 100$	mA

**Table 46. ESD and Latch-up Protection Characteristics (continued)**

Ratings	Symbol	Value	Unit
ESD GUN - LIN Conformance Test Specification <sup>(58)</sup> , unpowered, contact discharge, $C_{ZAP} = 150 \text{ pF}$ , $R_{ZAP} = 330 \Omega$ . - LIN (with or without bus filter $C_{BUS} = 220 \text{ pF}$ ) - VS1, VS2 with $C_{VS}$ - Lx with serial $R_{LX}$		$\pm 15000$ $\pm 20000$ $\pm 6000$	V
ESD GUN - IEC 61000-4-2 Test Specification <sup>(59)</sup> , unpowered, contact discharge, $C_{ZAP} = 150 \text{ pF}$ , $R_{ZAP} = 330 \Omega$ - LIN (with or without bus filter $C_{BUS} = 220 \text{ pF}$ ) - VSENSE with serial $R_{VSENSE}$ <sup>(57)</sup> - VS1, VS2 with $C_{VS}$ - Lx with serial $R_{LX}$		$\pm 8000$ $\pm 8000$ $\pm 8000$ $\pm 8000$	V
ESD GUN - ISO10605 Test Specification <sup>(59)</sup> , unpowered, contact discharge, $C_{ZAP} = 150 \text{ pF}$ , $R_{ZAP} = 2.0 \text{ k}\Omega$ - LIN (with or without bus filter $C_{BUS} = 220 \text{ pF}$ ) - VSENSE with serial $R_{VSENSE}$ <sup>(57)</sup> - VS1, VS2 with $C_{VS}$ - Lx with serial $R_{LX}$		$\pm 6000$ $\pm 6000$ $\pm 6000$ $\pm 6000$	V
ESD GUN - ISO10605 Test Specification <sup>(59)</sup> , powered, contact discharge, $C_{ZAP} = 330 \text{ pF}$ , $R_{ZAP} = 2.0 \text{ k}\Omega$ - LIN (with or without bus filter $C_{BUS} = 220 \text{ pF}$ ) - VSENSE with serial $R_{VSENSE}$ <sup>(57)</sup> - VS1, VS2 with $C_{VS}$ - Lx with serial $R_{LX}$		$\pm 8000$ $\pm 8000$ $\pm 8000$ $\pm 8000$	V

Note:

- 56. Input Voltage Limit = -2.5 to 7.5 V.
- 57. With  $C_{VBAT}$  (10...100 nF) as part of the battery path.
- 58. Certification available on request
- 59. Tested internally only; certification pending

### 3.9 Additional Test Information ISO7637-2

For immunity against transients for the LIN, Lx, and VBAT is specified according to the LIN Conformance Test Specification - Section LIN EMC Test Specification refer to the LIN Conformance Test Certification Report - available as a separate document from [ISO](#).

## 4 Functional Description and Application Information

### 4.1 Introduction

This chapter describes the MM912F634 dual die device functions on a block by block base. To distinguish between the module location being the MCU die or the analog die, the following symbols are shown on all module cover pages:

The documented module is physically located on the Analog die. This applies to [Section 4.2, “MM912F634 - Analog Die Overview”](#) through [Section 4.25, “MM912F634 - Analog Die Trimming”](#).

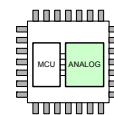

The documented module is physically located on the Microcontroller die. This applies to [Section 4.26, “MM912F634 - MCU Die Overview”](#) through [Section 4.38, “Serial Peripheral Interface \(S12SPIV4\)”](#).

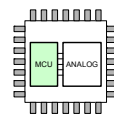

Sections concerning both dies or the complete device does not have a specific indication.

#### 4.1.1 Device Register Maps

[Table 47](#) shows the device register memory map overview for the 32 kByte MCU die (MC9S12I32).

**NOTE**

Reserved register space shown in [Table 47](#) is not allocated to any module. This register space is reserved for future use, and shows as grayed areas in tables throughout this document. Writing to these locations has no effect. Read access to these locations returns zero.

**Table 47. Device Register Memory Map Overview**

Address	Module	Size (Bytes)
0x0000–0x0007	PIM (port integration module)	8
0x0008–0x0019	Reserved	18
0x001A–0x001B	Part ID register	2
0x001C–0x001E	Reserved	3
0x001F	INT (interrupt module)	1
0x0020–0x002F	DBG (debug module)	16
0x0030–0x0033	MMC (memory map control)	4
0x0034–0x003B	CRG (clock and reset generator)	8
0x003C–0x003D	RTI (real time interrupt)	2
0x003E–0x003F	COP (computer operating properly)	2
0x0040–0x00D7	Reserved	152
0x00D8–0x00DF	D2DI (die 2 die initiator)	8
0x00E0–0x00E7	Reserved	8
0x00E8–0x00EF	SPI (serial peripheral interface)	8
0x00F0–0x00FF	Reserved	16
0x0100–0x0113	FTSR control registers	20
0x0114–0x011F	Reserved	12
0x0120–0x0123	PIM (port integration module)	4
0x0124–0x01FF	Reserved	220

**Table 47. Device Register Memory Map Overview (continued)**

Address	Module	Size (Bytes)
0x0200–0x02FF	D2DI (die 2 die initiator, blocking access window)	256
0x0300–0x03FF	D2DI (die 2 die initiator, non-blocking access window)	256

### 4.1.2 Detailed Module Register Maps

Table 48 to Table 65 show the detailed module maps of the MM912F634 MCU die.

**Table 48. 0x0000–0x0017 Port Integration Module (PIM) 1of 2**

Address	Name		Bit 7	Bit 6	Bit 5	Bit 4	Bit 3	Bit 2	Bit 1	Bit 0
0x0000	PTA	R	0	0	PTA5	PTA4	PTA3	PTA2	PTA1	PTA 0
		W								
0x0001	Reserved	R	0	0	0	0	0	0	0	0
		W								
0x0002	DDRA	R	0	0	DDRA5	DDRA4	DDRA3	DDRA2	DDRA1	DDRA0
		W								
0x0003	Reserved	R	0	0	0	0	0	0	0	0
		W								
0x0004	PTC	R	0	0	0	0	0	PTC1	PTC0	
		W								
0x0005	PTD	R	PTD7	PTD6	PTD5	PTD4	PTD3	PTD2	PTD1	PTD0
		W								
0x0006	DDRC	R	0	0	0	0	0	DDRC1	DDRC0	
		W								
0x0007	DDRD	R	DDRD7	DDRD6	DDRD5	DDRD4	DDRD3	DDRD2	DDRD1	DDRD0
		W								
0x0008– 0x0017	Reserved	R	0	0	0	0	0	0	0	0
		W								

**Table 49. 0x0018–0x001E Miscellaneous Peripheral**

Address	Name		Bit 7	Bit 6	Bit 5	Bit 4	Bit 3	Bit 2	Bit 1	Bit 0
0x0018–0x 0019	Reserved	R	0	0	0	0	0	0	0	0
		W								
0x001A	PARTIDH	R	PARTIDH							
		W								
0x001B	PARTIDL	R	PARTIDL							
		W								
0x001C– 0x001E	Reserved	R	0	0	0	0	0	0	0	0
		W								

**Table 50. 0x001F Interrupt Module (S12SINT)**

0x001F	IVBR	R	IVB_ADDR[7:0]
		W	

**Table 51. 0x0020–0x002F Debug Module (S12XDBG)**

Address	Name		Bit 7	Bit 6	Bit 5	Bit 4	Bit 3	Bit 2	Bit 1	Bit 0
0x0020	DBGC1	R	ARM	0	0	BDM	DBGBRK	0	COMRV	
		W		TRIG						
0x0021	DBGSR	R	TBF <sup>(60)</sup>	0	0	0	0	SSF2	SSF1	SSF0
		W								
0x0022	DBGTCR	R	0	TSOURCE	0	0	TRCMOD		0	TALIGN
		W								
0x0023	DBGC2	R	0	0	0	0	0	0	ABCM	
		W								
0x0024	DBGTBH	R	Bit 15	Bit 14	Bit 13	Bit 12	Bit 11	Bit 10	Bit 9	Bit 8
		W								
0x0025	DBGTBL	R	Bit 7	Bit 6	Bit 5	Bit 4	Bit 3	Bit 2	Bit 1	Bit 0
		W								
0x0026	DBGCNT	R	TBF <sup>(60)</sup>	0	CNT					
		W								
0x0027	DBGSCRX	R	0	0	0	0	0	SC2	SC1	SC0
		W								
0x0027	DBGMFR	R	0	0	0	0	0	MC2	MC1	MC0
		W								
0x0028 <sup>(61)</sup>	DBGACTL	R	0	NDB	TAG	BRK	RW	RWE	0	COMPE
		W								
0x0028 <sup>(62)</sup>	DBGBCTL	R	SZE	SZ	TAG	BRK	RW	RWE	0	COMPE
		W								
0x0028 <sup>(63)</sup>	DBGCCTL	R	0	0	TAG	BRK	RW	RWE	0	COMPE
		W								
0x0029	DBGXAH	R	0	0	0	0	0	0	Bit 17	Bit 16
		W								
0x002A	DBGXAM	R	Bit 15	14	13	12	11	10	9	Bit 8
		W								
0x002B	DBGXAL	R	Bit 7	6	5	4	3	2	1	Bit 0
		W								
0x002C	DBGADH	R	Bit 15	14	13	12	11	10	9	Bit 8
		W								
0x002D	DBGADL	R	Bit 7	6	5	4	3	2	1	Bit 0
		W								

**Table 51. 0x0020–0x002F Debug Module (S12XDBG) (continued)**

Address	Name		Bit 7	Bit 6	Bit 5	Bit 4	Bit 3	Bit 2	Bit 1	Bit 0
0x002E	DBGADHM	R	Bit 15	14	13	12	11	10	9	Bit 8
		W								
0x002F	DBGADLM	R	Bit 7	6	5	4	3	2	1	Bit 0
		W								

Note:

- 60. This bit is visible at DBGCNT[7] and DBGSR[7]
- 61. This represents the contents if the Comparator A control register is blended into this address.
- 62. This represents the contents if the Comparator B control register is blended into this address.
- 63. This represents the contents if the Comparator C control register is blended into this address.

**Table 52. 0x0030–0x0033 Module Mapping Control (S12SMCC)**

Address	Name		Bit 7	Bit 6	Bit 5	Bit 4	Bit 3	Bit 2	Bit 1	Bit 0
0x0030	PPAGE	R	0	0	0	0	PIX3	PIX2	PIX1	PIX0
		W								
0x0031	DIRECT	R	DP15	DP14	DP13	DP12	DP11	DP10	DP9	DP8
		W								
0x0032	MODE	R	MODC	0	0	0	0	0	0	0
		W								
0x0033	MMCCTL1	R	0	0	0	0	0	0	0	IFRON
		W								

**Table 53. 0x0034–0x003B Clock and Reset Generator (CRG)**

Address	Name		Bit 7	Bit 6	Bit 5	Bit 4	Bit 3	Bit 2	Bit 1	Bit 0
0x0034	CRGCTL0	R	OSCEN	RDIV[2:0]			BCLKS	REFS	OSC4MHZ	0
		W								
0x0035	CRGCTL1	R	BDIV[3:0]				0	0	LOCKIE	
		W								
0x0036	CRGMULT	R	MULT[6:0]							
		W								
0x0037	CRGFLG	R	0	PORF	0	LOCKIF	LOCKST	ILAF	UPOSC	0
		W								
0x0038	CRGTRIMH	R	0	0	0	0	0	0	0	TRIM[8]
		W								
0x0039	CRGTRIML	R	TRIM[7:0]							
		W								
0x003A	Reserved	R	0	0	0	0	0	0	0	0
		W								

**Table 54. 0x003C–0x003D Real Time Interrupt (RTI)**

Address	Name	Bit 7	Bit 6	Bit 5	Bit 4	Bit 3	Bit 2	Bit 1	Bit 0	
0x003C	RTICTL	R	RTIF	RTIFRZ	0	RTISWAI	RTIRSTP	RTIE	RTIRT1	RTIRT0
		W			WRTMSK					
0x003D	RTICNT	R	RTICNT7	RTICNT6	RTICNT5	RTICNT4	RTICNT3	RTICNT2	RTICNT1	RTICNT0
		W								

**Table 55. 0x003E–0x003F Computer Operating Properly (COP)**

Address	Name	Bit 7	Bit 6	Bit 5	Bit 4	Bit 3	Bit 2	Bit 1	Bit 0	
0x003E	COPCTL	R	WCOP	RSBCK	0	COPWAI	COPSTP	CR2	CR1	CR0
		W			WRTMSK					
0x003F	ARMCOP	R	0	0	0	0	0	0	0	0
		W	Bit 7	Bit 6	Bit 5	Bit 4	Bit 3	Bit 2	Bit 1	Bit 0

**Table 56. 0x0040–0x00D7 Reserved Register Space**

Address	Name	Bit 7	Bit 6	Bit 5	Bit 4	Bit 3	Bit 2	Bit 1	Bit 0
0x0040-0x00D7	Reserved	R	0	0	0	0	0	0	0
		W							

**Table 57. 0x00D8–0x00DF Die 2 Die Initiator (D2DI) 1 of 3**

Address	Name	Bit 7	Bit 6	Bit 5	Bit 4	Bit 3	Bit 2	Bit 1	Bit 0	
0x00D8	D2DCTL0	R	D2DEN	D2DCW	D2DSWAI	0	0	0	D2DCLKDIV[1:0]	
		W								
0x00D9	D2DCTL1	R	D2DIE	0	0	0	TIMOUT[3:0]			
		W								
0x00DA	D2DSTAT0	R	ERRIF	ACKERF	CNCLF	TIMEF	TERRF	PARF	PAR1	PAR0
		W								
0x00DB	D2DSTAT1	R	D2DIF	D2DBSY	0	0	0	0	0	0
		W								
0x00DC	D2DADRHI	R	RWB	SZ8	0	NBLK	0	0	0	0
		W								
0x00DD	D2DADRLO	R	ADR[7:0]							
		W								
0x00DE	D2DDATAHI	R	DATA[15:8]							
		W								
0x00DF	D2DDATALO	R	DATA[7:0]							
		W								

**Table 58. 0x00E0–0x00E7 Reserved Register Space**

Address	Name		Bit 7	Bit 6	Bit 5	Bit 4	Bit 3	Bit 2	Bit 1	Bit 0
0x00E0-0x00E7	Reserved	R	0	0	0	0	0	0	0	0
		W								

**Table 59. 0x00E8–0x00EF Serial Peripheral Interface (SPI)**

Address	Name		Bit 7	Bit 6	Bit 5	Bit 4	Bit 3	Bit 2	Bit 1	Bit 0
0x00E8	SPI0CR1	R	SPIE	SPE	SPTIE	MSTR	CPOL	CPHA	SSOE	LSBFE
		W								
0x00E9	SPI0CR2	R	0	0	0	MODFEN	BIDIROE	0	SPISWAI	SPC0
		W								
0x00EA	SPI0BR	R	0	SPPR2	SPPR1	SPPR0	0	SPR2	SPR1	SPR0
		W								
0x00EB	SPI0SR	R	SPIF	0	SPTEF	MODF	0	0	0	0
		W								
0x00EC	Reserved	R	0	0	0	0	0	0	0	0
		W								
0x00ED	SPI0DR	R	Bit 7	Bit 6	Bit 5	Bit 4	Bit 3	Bit 2	Bit 1	Bit 0
		W								
0x00EE	Reserved	R	0	0	0	0	0	0	0	0
		W								
0x00EF	Reserved	R	0	0	0	0	0	0	0	0
		W								

**Table 60. 0x00F0–0x00FF Reserved Register Space**

Address	Name		Bit 7	Bit 6	Bit 5	Bit 4	Bit 3	Bit 2	Bit 1	Bit 0
0x00F0-0x00FF	Reserved	R	0	0	0	0	0	0	0	0
		W								

**Table 61. 0x0100–0x0113 Flash Control & Status Register FTSR**

Address	Name		Bit 7	Bit 6	Bit 5	Bit 4	Bit 3	Bit 2	Bit 1	Bit 0
0x0100	FCLKDIV	R	FDIVLD	PRDIV8	FDIV5	FDIV4	FDIV3	FDIV2	FDIV1	FDIV0
		W								
0x0101	FSEC	R	KEYEN1	KEYEN0	0	0	0	0	SEC1	SEC0
		W								
0x0102	FRSV0	R	0	0	0	0	0	0	0	0
		W								
0x0103	FCNFG	R	CBEIE	CCIE	KEYACC	0	0	0	0	0
		W								

**Table 61. 0x0100–0x0113 Flash Control & Status Register FTSR (continued)**

Address	Name		Bit 7	Bit 6	Bit 5	Bit 4	Bit 3	Bit 2	Bit 1	Bit 0
0x0104	FPROT	R	FPHS4	FPHS3	FPHS2	FPHS1	FPHS0	FPLS2	FPLS1	FPLS0
		W								
0x0105	FSTAT	R	CBEIF	CCIF	PVIOL	ACCERR	0	BLANK	0	0
		W								
0x0106	FCMD	R	0	CMDB6	CMDB5	CMDB4	CMDB3	CMDB2	CMDB1	CMDB0
		W								
0x0107	FRSV1	R	0	0	0	0	0	0	0	0
		W								
0x0108	FADDRHI	R	0	0	0	0	0	0	0	0
		W			FAB13	FAB12	FAB11	FAB10	FAB9	FAB8
0x0109	FADDRLO	R	0	0	0	0	0	0	0	0
		W	FAB7	FAB6	FAB5	FAB4	FAB3	FAB2	FAB1	FAB0
0x010A	FDATAHI	R	FD15	FD14	FD13	FD12	FD11	FD10	FD9	FD8
		W								
0x010B	FDATALO	R	FD7	FD6	FD5	FD4	FD3	FD2	FD1	FD0
		W								
0x010C	FRSV2	R	0	0	0	0	0	0	0	0
		W								
0x010D	FRSV3	R	0	0	0	0	0	0	0	0
		W								
0x010E	FRSV4	R	0	0	0	0	0	0	0	0
		W								
0x010F	FRSV5	R	0	0	0	0	0	0	0	0
		W								
0x0110- 0x0113	Reserved	R	0	0	0	0	0	0	0	0
		W								

**Table 62. 0x0114–0x011F Reserved Register Space**

Address	Name		Bit 7	Bit 6	Bit 5	Bit 4	Bit 3	Bit 2	Bit 1	Bit 0
0x0114- 0x011F	Reserved	R	0	0	0	0	0	0	0	0
		W								

**Table 63. 0x0120–0x0123 Port Integration Module (PIM) 2 of 2**

Address	Name		Bit 7	Bit 6	Bit 5	Bit 4	Bit 3	Bit 2	Bit 1	Bit 0
0x0120	PTIA	R	0	0	PTIA5	PTIA4	PTIA3	PTIA2	PTIA1	PTIA0
		W								
0x0121	Reserved	R	0	0	0	0	0	0	0	0
		W								

**Table 63. 0x0120–0x0123 Port Integration Module (PIM) 2 of 2 (continued)**

0x0122	RDRA	R	0	0	RDRA5	RDRA4	RDRA3	RDRA2	RDRA1	RDRA0
		W								
0x0123	Reserved	R	0	0	0	0	0	0	0	0
		W								

**Table 64. 0x0124–0x01FF Reserved Register Space**

Address	Name		Bit 7	Bit 6	Bit 5	Bit 4	Bit 3	Bit 2	Bit 1	Bit 0
0x0124- 0x01FF	Reserved	R	0	0	0	0	0	0	0	0
		W								

Table 65 shows the detailed module maps of the MM912F634 analog die.

**Table 65. Analog die Registers<sup>(64)</sup> - 0x0200–0x02FF D2D Blocking Access (D2DI) 2 of 3/  
0x0300–0x03FF D2D Non Blocking Access (D2DI) 3 of 3**

Offset	Name		7	6	5	4	3	2	1	0
0x00	ISR (hi)	R	0	0	HOT	LSOT	HSOT	LINOT	SCI	RX
	Interrupt Source Register	W								
0x01	ISR (lo)	R	TX	ERR	TOV	CH3	CH2	CH1	CH0	VSI
	Interrupt Source Register	W								
0x02	IVR	R	0	0	IRQ					
	Interrupt Vector Register	W								
0x04	VCR	R	0	0	0	VROVIE	HTIE	HVIE	LVIE	LBIE
	Voltage Control Register	W								
0x05	VSR	R	0	0	0	VROVC	HTC	HVC	LVC	LBC
	Voltage Status Register	W								
0x08	LXR	R	0	0	L5	L4	L3	L2	L1	L0
	Lx Status Register	W								
0x09	LXCR	R	0	0	L5DS	L4DS	L3DS	L2DS	L1DS	L0DS
	Lx Control Register	W								
0x10	WDR	R	WDOFF	WDWO	0	0	0	WDTO		
	Watchdog Register	W								
0x11	WDSR	R	WDSR							
	Watchdog Service Register	W								
0x12	WCR	R	CSSEL		L5WE	L4WE	L3WE	L2WE	L1WE	L0WE
	Wake Up Control Register	W								
0x13	TCR	R	FWM				CST			
	Timing Control Register	W								
0x14	WSR	R	FWU	LINWU	L5WU	L4WU	L3WU	L2WU	L1WU	L0WU
	Wake Up Source Register	W								

**Table 65. Analog die Registers<sup>(64)</sup> - 0x0200–0x02FF D2D Blocking Access (D2DI) 2 of 3/  
0x0300–0x03FF D2D Non Blocking Access (D2DI) 3 of 3 (continued)**

Offset	Name		7	6	5	4	3	2	1	0
0x15	RSR	R	0	0	WDR	EXR	WUR	LVRX	LVR	POR
	Reset Status Register	W								
0x16	MCR	R	0	0	0	0	0	0	MODE	
	Mode Control Register	W								
0x18	LINR	R		LINOTC	RX	TX	LVSD	LINEN	LINSR	
	LIN Register	W	LINOTIE							
0x20	PTBC1	R	0	PUEB2	PUEB1	PUEB0	0	DDR2	DDR1	DDR0
	Port B Configuration Register 1	W								
0x21	PTBC2	R	0	0	0	0	PWMCS	PWMEN	SERMOD	
	Port B Config Register 2	W								
0x22	PTB	R	0	0	0	0	0	PTB2	PTB1	PTB0
	Port B Data Register	W								
0x28	HSCR	R	HSOTIE	HSHVSDE	PWMCS2	PWMCS1	PWMHS2	PWMHS1	HS2	HS1
	High-side Control Register	W								
0x29	HSSR	R	HSOTC	0	0	0	HS2CL	HS1CL	HS2OL	HS1OL
	High-side Status Register	W								
0x30	LSCR	R		0	PWMCS2	PWMCS1	PWMLS2	PWMLS1	LS2	LS1
	Low-side Control Register	W	LSOTIE							
0x31	LSSR	R	LSOTC	0	0	0	LS2CL	LS1CL	LS2OL	LS1OL
	Low-side Status Register	W								
0x32	LSCEN	R	0	0	0	0	LSCEN			
	Low-Side Control Enable Register	W								
0x38	HSR	R		HOTC	0	0	0	0	0	HSUPON
	Hall Supply Register	W	HOTIE							
0x3C	CSR	R		0	0	0	CCD	CSGS		
	Current Sense Register	W	CSE							
0x40	SCIBD (hi)	R	LBKDIE	RXEDGIE	0	SBR12	SBR11	SBR10	SBR9	SBR8
	SCI Baud Rate Register	W								
0x41	SCIBD (lo)	R	SBR7	SBR6	SBR5	SBR4	SBR3	SBR2	SBR1	SBR0
	SCI Baud Rate Register	W								
0x42	SCIC1	R	LOOPS	0	RSRC	M	0	ILT	PE	PT
	SCI Control Register 1	W								
0x43	SCIC2	R	TIE	TCIE	RIE	ILIE	TE	RE	RWU	SBK
	SCI Control Register 2	W								
0x44	SCIS1	R	TDRE	TC	RDRF	IDLE	OR	NF	FE	PF
	SCI Status Register 1	W								
0x45	SCIS2	R			0	RXINV	RWUID	BRK13	LBKDE	RAF
	SCI Status Register 2	W	LBKDIF	RXEDGIF						

**Table 65. Analog die Registers<sup>(64)</sup> - 0x0200–0x02FF D2D Blocking Access (D2DI) 2 of 3/  
0x0300–0x03FF D2D Non Blocking Access (D2DI) 3 of 3 (continued)**

Offset	Name		7	6	5	4	3	2	1	0
0x46	SCIC3	R	R8	T8	TXDIR	TXINV	ORIE	NEIE	FEIE	PEIE
	SCI Control Register 3	W								
0x47	SCID	R	R7	R6	R5	R4	R3	R2	R1	R0
	SCI Data Register	W	T7	T6	T5	T4	T3	T2	T1	T0
0x60	PWMCTL	R	CAE1	CAE0	PCLK1	PCLK0	PPOL1	PPOL0	PWME1	PWME0
	PWM Control Register	W								
0x61	PWMPRCLK	R	0	PCKB2	PCKB1	PCKB0	0	PCKA2	PCKA1	PCKA0
	PWM Presc. Clk Select Reg	W								
0x62	PWMSCLA	R	Bit 7	6	5	4	3	2	1	Bit 0
	PWM Scale A Register	W								
0x63	PWMSCLB	R	Bit 7	6	5	4	3	2	1	Bit 0
	PWM Scale B Register	W								
0x64	PWMCNT0	R	Bit 7	6	5	4	3	2	1	Bit 0
	PWM Ch Counter Reg 0	W	0	0	0	0	0	0	0	0
0x65	PWMCNT1	R	Bit 7	6	5	4	3	2	1	Bit 0
	PWM Ch Counter Reg 1	W	0	0	0	0	0	0	0	0
0x66	PWMPER0	R	Bit 7	6	5	4	3	2	1	Bit 0
	PWM Ch Period Register 0	W								
0x67	PWMPER1	R	Bit 7	6	5	4	3	2	1	Bit 0
	PWM Ch Period Register 1	W								
0x68	PWMDTY0	R	Bit 7	6	5	4	3	2	1	Bit 0
	PWM Ch Duty Register 0	W								
0x69	PWMDTY1	R	Bit 7	6	5	4	3	2	1	Bit 0
	PWM Ch Duty Register 1	W								
0x80	ACR	R	SCIE	CCE	OCE	ADCRST	0	PS2	PS1	PS0
	ADC Config Register	W								
0x81	ASR	R	SCF	2p5CLF	0	0	CCNT3	CCNT2	CCNT1	CCNT0
	ADC Status Register	W								
0x82	ACCR (hi)	R	CH15	CH14	0	CH12	CH11	CH10	CH9	CH8
	ADC Conversion Ctrl Reg	W								
0x83	ACCR (lo)	R	CH7	CH6	CH5	CH4	CH3	CH2	CH1	CH0
	ADC Conversion Ctrl Reg	W								
0x84	ACCSR (hi)	R	CC15	CC14	0	CC12	CC11	CC10	CC9	CC8
	ADC Conv Complete Reg	W								
0x85	ACCSR (lo)	R	CC7	CC6	CC5	CC4	CC3	CC2	CC1	CC0
	ADC Conv Complete Reg	W								
0x86	ADR0 (hi)	R	adr0 9	adr0 8	adr0 7	adr0 6	adr0 5	adr0 4	adr0 3	adr0 2
	ADC Data Result Register 0	W								

**Table 65. Analog die Registers<sup>(64)</sup> - 0x0200–0x02FF D2D Blocking Access (D2DI) 2 of 3/  
0x0300–0x03FF D2D Non Blocking Access (D2DI) 3 of 3 (continued)**

Offset	Name		7	6	5	4	3	2	1	0
0x87	ADR0 (lo)	R	adr0 1	adr0 0	0	0	0	0	0	0
	ADC Data Result Register 0	W								
0x88	ADR1 (hi)	R	adr1 9	adr1 8	adr1 7	adr1 6	adr1 5	adr1 4	adr1 3	adr1 2
	ADC Data Result Register 1	W								
0x89	ADR1 (lo)	R	adr1 1	adr1 0	0	0	0	0	0	0
	ADC Data Result Register 1	W								
0x8A	ADR2 (hi)	R	adr2 9	adr2 8	adr2 7	adr2 6	adr2 5	adr2 4	adr2 3	adr2 2
	ADC Data Result Register 2	W								
0x8B	ADR2 (lo)	R	adr2 1	adr2 0	0	0	0	0	0	0
	ADC Data Result Register 2	W								
0x8C	ADR3 (hi)	R	adr3 9	adr3 8	adr3 7	adr3 6	adr3 5	adr3 4	adr3 3	adr3 2
	ADC Data Result Register 3	W								
0x8D	ADR3 (lo)	R	adr3 1	adr3 0	0	0	0	0	0	0
	ADC Data Result Register 3	W								
0x8E	ADR4 (hi)	R	adr4 9	adr4 8	adr4 7	adr4 6	adr4 5	adr4 4	adr4 3	adr4 2
	ADC Data Result Register 4	W								
0x8F	ADR4 (lo)	R	adr4 1	adr4 0	0	0	0	0	0	0
	ADC Data Result Register 4	W								
0x90	ADR5 (hi)	R	adr5 9	adr5 8	adr5 7	adr5 6	adr5 5	adr5 4	adr5 3	adr5 2
	ADC Data Result Register 5	W								
0x91	ADR5 (lo)	R	adr5 1	adr5 0	0	0	0	0	0	0
	ADC Data Result Register 5	W								
0x92	ADR6 (hi)	R	adr6 9	adr6 8	adr6 7	adr6 6	adr6 5	adr6 4	adr6 3	adr6 2
	ADC Data Result Register 6	W								
0x93	ADR6 (lo)	R	adr6 1	adr6 0	0	0	0	0	0	0
	ADC Data Result Register 6	W								
0x94	ADR7 (hi)	R	adr7 9	adr7 8	adr7 7	adr7 6	adr7 5	adr7 4	adr7 3	adr7 2
	ADC Data Result Register 7	W								
0x95	ADR7 (lo)	R	adr7 1	adr7 0	0	0	0	0	0	0
	ADC Data Result Register 7	W								
0x96	ADR8 (hi)	R	adr8 9	adr8 8	adr8 7	adr8 6	adr8 5	adr8 4	adr8 3	adr8 2
	ADC Data Result Register 8	W								
0x97	ADR8 (lo)	R	adr8 1	adr8 0	0	0	0	0	0	0
	ADC Data Result Register 8	W								
0x98	ADR9 (hi)	R	adr9 9	adr9 8	adr9 7	adr9 6	adr9 5	adr9 4	adr9 3	adr9 2
	ADC Data Result Register 9	W								
0x99	ADR9 (lo)	R	adr9 1	adr9 0	0	0	0	0	0	0
	ADC Data Result Register 9	W								

**Table 65. Analog die Registers<sup>(64)</sup> - 0x0200–0x02FF D2D Blocking Access (D2DI) 2 of 3/  
0x0300–0x03FF D2D Non Blocking Access (D2DI) 3 of 3 (continued)**

Offset	Name		7	6	5	4	3	2	1	0
0x9A	ADR10 (hi)	R	adr10 9	adr10 8	adr10 7	adr10 6	adr10 5	adr10 4	adr10 3	adr10 2
	ADC Data Result Reg 10	W								
0x9B	ADR10 (lo)	R	adr10 1	adr10 0	0	0	0	0	0	0
	ADC Data Result Reg 10	W								
0x9C	ADR11 (hi)	R	adr11 9	adr11 8	adr11 7	adr11 6	adr11 5	adr11 4	adr11 3	adr11 2
	ADC Data Result Reg 11	W								
0x9D	ADR11 (lo)	R	adr11 1	adr11 0	0	0	0	0	0	0
	ADC Data Result Reg 11	W								
0x9E	ADR12 (hi)	R	adr12 9	adr12 8	adr12 7	adr12 6	adr12 5	adr12 4	adr12 3	adr12 2
	ADC Data Result Reg 12	W								
0x9F	ADR12 (lo)	R	adr12 1	adr12 0	0	0	0	0	0	0
	ADC Data Result Reg 12	W								
0xA2	ADR14 (hi)	R	adr14 9	adr14 8	adr14 7	adr14 6	adr14 5	adr14 4	adr14 3	adr14 2
	ADC Data Result Reg 14	W								
0xA3	ADR14 (lo)	R	adr14 1	adr14 0	0	0	0	0	0	0
	ADC Data Result Reg 14	W								
0xA4	ADR15 (hi)	R	adr15 9	adr15 8	adr15 7	adr15 6	adr15 5	adr15 4	adr15 3	adr15 2
	ADC Data Result Reg 15	W								
0xA5	ADR15 (lo)	R	adr15 1	adr15 0	0	0	0	0	0	0
	ADC Data Result Reg 15	W								
0xC0	TIOS	R	0	0	0	0	IOS3	IOS2	IOS1	IOS0
	TIM InCap/OutComp Select	W								
0xC1	CFORC	R	0	0	0	0	0	0	0	0
	Timer Compare Force Reg	W					FOC3	FOC2	FOC1	FOC0
0xC2	OC3M	R	0	0	0	0	OC3M3	OC3M2	OC3M1	OC3M0
	Output Comp 3 Mask Reg	W								
0xC3	OC3D	R	0	0	0	0	OC3D3	OC3D2	OC3D1	OC3D0
	Output Comp 3 Data Reg	W								
0xC4	TCNT (hi)	R	tcnt 15	tcnt 14	tcnt 13	tcnt 12	tcnt 11	tcnt 10	tcnt 9	tcnt 8
	Timer Count Register	W								
0xC5	TCNT (lo)	R	tcnt 7	tcnt 6	tcnt 5	tcnt 4	tcnt 3	tcnt 2	tcnt 1	tcnt 0
	Timer Count Register	W								
0xC6	TSCR1	R	TEN	0	0	TFFCA	0	0	0	0
	Timer System Control Reg 1	W								
0xC7	TTOV	R	0	0	0	0	TOV3	TOV2	TOV1	TOV0
	Timer Toggle Overflow Reg	W								
0xC8	TCTL1	R	OM3	OL3	OM2	OL2	OM1	OL1	OM0	OL0
	Timer Control Register 1	W								

**Table 65. Analog die Registers<sup>(64)</sup> - 0x0200–0x02FF D2D Blocking Access (D2DI) 2 of 3/  
0x0300–0x03FF D2D Non Blocking Access (D2DI) 3 of 3 (continued)**

Offset	Name		7	6	5	4	3	2	1	0
0xC9	TCTL2	R								
	Timer Control Register 2	W	EDG3B	EDG3A	EDG2B	EDG2A	EDG1B	EDG1A	EDG0B	EDG0A
0xCA	TIE	R	0	0	0	0	C3I	C2I	C1I	C0I
	Timer Interrupt Enable Reg	W								
0xCB	TSCR2	R	TOI	0	0	0	TCRE	PR2	PR1	PR0
	Timer System Control Reg 2	W								
0xCC	TFLG1	R	0	0	0	0	C3F	C2F	C1F	C0F
	Main Timer Interrupt Flag 1	W								
0xCD	TFLG2	R	TOF	0	0	0	0	0	0	0
	Main Timer Interrupt Flag 2	W								
0xCE	TC0 (hi)	R	tc0 15	tc0 14	tc0 13	tc0 12	tc0 11	tc0 10	tc0 9	tc0 8
	TIM InCap/OutComp Reg 0	W								
0xCF	TC0 (lo)	R	tc0 7	tc0 6	tc0 5	tc0 4	tc0 3	tc0 2	tc0 1	tc0 0
	TIM InCap/OutComp Reg 0	W								
0xD0	TC1 (hi)	R	tc1 15	tc1 14	tc1 13	tc1 12	tc1 11	tc1 10	tc1 9	tc1 8
	TIM InCap/OutComp Reg 1	W								
0xD1	TC1 (lo)	R	tc1 7	tc1 6	tc1 5	tc1 4	tc1 3	tc1 2	tc1 1	tc1 0
	TIM InCap/OutComp Reg 1	W								
0xD2	TC2 (hi)	R	tc2 15	tc2 14	tc2 13	tc2 12	tc2 11	tc2 10	tc2 9	tc2 8
	TIM InCap/OutComp Reg 2	W								
0xD3	TC2 (lo)	R	tc2 7	tc2 6	tc2 5	tc2 4	tc2 3	tc2 2	tc2 1	tc2 0
	TIM InCap/OutComp Reg 2	W								
0xD4	TC3 (hi)	R	tc3 15	tc3 14	tc3 13	tc3 12	tc3 11	tc3 10	tc3 9	tc3 8
	TIM InCap/OutComp Reg 3	W								
0xD5	TC3 (lo)	R	tc3 7	tc3 6	tc3 5	tc3 4	tc3 3	tc3 2	tc3 1	tc3 0
	TIM InCap/OutComp Reg 3	W								
0xF0	CTR0	R	LINTRE	LINTR	WDCTRE	CTR0_4	CTR0_3	WDCTR2	WDCTR1	WDCTR0
	Trimming Reg 0	W								
0xF1	CTR1	R	BGTRE	CTR1_6	BGTRIMU P	BGTRIMD N	IREFTRE	IREFTR2	IREFTR1	IREFTR0
	Trimming Reg 1	W								
0xF2	CTR2	R	0	0	0	SLPBGTR E	SLPBG_L OCK	SLPBGTR 2	SLPBGTR 1	SLPBGTR 0
	Trimming Reg 2	W								
0xF3	CTR3	R	OFFCTRE	OFFCTR2	OFFCTR1	OFFCTR0	CTR3_E	CTR3_2	CTR3_1	CTR3_0
	Trimming Reg 3	W								
0xF4	SRR	R	0	0	0	0	FMREV		MMREV	
	Silicon Revision Register	W								

Note:

64. Registers not shown are reserved and must not be accessed.

## 4.2 MM912F634 - Analog Die Overview

### 4.2.1 Introduction

The MM912F634 analog die implements all system base functionality to operate the integrated microcontroller, and delivers application specific actuator control as well as input capturing.

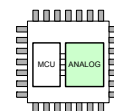

### 4.2.2 System Registers

#### 4.2.2.1 Silicon Revision Register (SRR)

**NOTE**

Refer to the [MM912F634ER](#) - Mask set errata document for details on the analog die mask revisions.

**Table 66. Silicon Revision Register (SRR)**

Offset <sup>(65)</sup>	0xF4							Access: User read
	7	6	5	4	3	2	1	0
R	0	0	0	0	FMREV		MMREV	
W								

Note:

65. Offset related to 0x0200 for blocking access and 0x300 for non blocking access within the global address space.

**Table 67. SRR - Register Field Descriptions**

Field	Description
3-2 FMREV	MM912F634 analog die Silicon Revision Register - These bits represent the revision of Silicon of the analog die. They are incremented for every full mask or metal mask issued of the device.
1-0 MMREV	One number is set for one revision of the silicon of the analog die.

### 4.2.3 Analog Die Options

**NOTE**

This document describes the features and functions of option 1 (all modules available and tested). Beyond this chapter, there is no additional note or differentiation between the different implementations.

The following section describes the differences between analog die options 1 and 2.

**Table 68. Analog Die Options**

Feature	Option 1	Option 2
Current Sense Module	YES	NO
Wake Up Inputs (Lx)	L0...L5	L0.L3

**4.2.3.1 Current Sense Module**

For device options with the current sense module not available, the following considerations are to be made.

**4.2.3.1.1 Pinout considerations**

**Table 69. ISENSE - Pin Considerations**

PIN	PIN name for option 1	New PIN name	Comment
40	ISENSEL	NC	ISENSE feature not bonded and/or not tested. Connect PINs 40 and 41 (NC) to GND.
41	ISENSEH	NC	

**4.2.3.1.2 Register Considerations**

The Current Sense Register must remain in default (0x00) state.

Offset	Name		7	6	5	4	3	2	1	0
0x3C	CSR	R	CSE	0	0	0	CCD	CSGS		
	Current Sense Register	W								

The Conversion Control Register - Bit 9 must always be written 0.

Offset	Name		15	14	13	12	11	10	9	8
0x82	ACCR (hi)	R	CH15	CH14	0	CH12	CH11	CH10	CH9	CH8
	ADC Conversion Ctrl Reg	W								

The Conversion Complete Register - Bit 9 must be ignored.

Offset	Name		15	14	13	12	11	10	9	8
0x84	ACCSR (hi)	R	CC15	CC14	0	CC12	CC11	CC10	CC9	CC8
	ADC Conv Complete Reg	W								

The ADC Data Result Reg 9 must be ignored.

Offset	Name		9	8	7	6	5	4	3	2
0x98	ADR9 (hi)	R	adr9 9	adr9 8	adr9 7	adr9 6	adr9 5	adr9 4	adr9 3	adr9 2
	ADC Data Result Register 9	W								
0x99	ADR9 (lo)	R	adr9 1	adr9 0	0	0	0	0	0	0
	ADC Data Result Register 9	W								

**4.2.3.1.3 Functional Considerations**

- The complete Current Sense Module is not available.
- The ADC Channel 9 is not available.

### 4.2.3.2 Wake-up Inputs (Lx)

For device options with reduced number of wake up inputs (Lx), the following considerations are to be made.

#### 4.2.3.2.1 Pinout Considerations

Table 70. Lx - Pin Considerations

PIN	PIN Name for Option 1	New PIN name	Comment
31...36	Lx	NC	One or more Lx wake up inputs are not available based on the analog die option. Not available Lx inputs are not bonded and/or not tested. Connect not available Lx pins (NC) to GND. R <sub>Lx</sub> is not required on those pins.

#### 4.2.3.2.2 Register Considerations

The Lx - Bit for the not available Lx input in the Lx Status Register must be ignored.

Offset	Name		7	6	5	4	3	2	1	0
0x08	LXR Lx Status Register	R	0	0	L5	L4	L3	L2	L1	L0
		W								

The Lx Control register for the not available Lx input must be written 0.

Offset	Name		7	6	5	4	3	2	1	0
0x09	LXCR Lx Control Register	R	0	0	L5DS	L4DS	L3DS	L2DS	L1DS	L0DS
		W								

A not available Lx input can not be selected as Wake-up Source and must have its LxWE bit set to 0.

Offset	Name		7	6	5	4	3	2	1	0
0x12	WCR Wake Up Control Register	R	CSSEL		L5WE	L4WE	L3WE	L2WE	L1WE	L0WE
		W								

The Wake-up Source Register for not available Lx inputs must be ignored.

Offset	Name		7	6	5	4	3	2	1	0
0x14	WSR Wake Up Source Register	R	FWU	LINWU	L5WU	L4WU	L3WU	L2WU	L1WU	L0WU
		W								

The Conversion Control Register for the not available Lx analog input (3...8) must always be written 0.

Offset	Name		7	6	5	4	3	2	1	0
0x82	ACCR (hi) ADC Conversion Ctrl Reg	R	CH15	CH14	0	CH12	CH11	CH10	CH9	CH8
		W								
0x83	ACCR (lo) ADC Conversion Ctrl Reg	R	CH7	CH6	CH5	CH4	CH3	CH2	CH1	CH0
		W								

The Conversion Complete Register for the not available Lx analog input (3.8) must be ignored.

Offset	Name		7	6	5	4	3	2	1	0
0x84	ACCSR (hi) ADC Conv Complete Reg	R	CC15	CC14	0	CC12	CC11	CC10	CC9	CC8
		W								
0x85	ACCSR (lo) ADC Conv Complete Reg	R	CC7	CC6	CC5	CC4	CC3	CC2	CC1	CC0
		W								

The ADC Data Result Register for the not available Lx analog input (3.8) must be ignored.

0x8C-0 x97	ADRx (hi)	R	adrx 9	adrx 8	adrx 7	adrx 6	adrx 5	adrx 4	adrx 3	adrx 2
	ADC Data Result Register x	W								
	ADRx (lo)	R	adrx 1	adrx 0	0	0	0	0	0	0
	ADC Data Result Register x	W								

#### 4.2.3.2.3 Functional Considerations

For the not available Lx inputs, the following functions are limited:

- No Wake-up feature / Cyclic Sense
- No Digital Input
- No Analog Input and conversion via ADC

### 4.3 Modes of Operation

The MM912F634 analog die offers three main operating modes: Normal (Run), Stop, and Sleep. In Normal mode, the device is active and is operating under normal application conditions. In Stop mode, the voltage regulator operates with limited current capability, the external load is expected to be reduced while in Stop mode. In Sleep mode both voltage regulators are turned off ( $V_{DD} = V_{DDX} = 0\text{ V}$ ).

Wake-up from Stop mode is indicated by an interrupt signal. Wake-up from Sleep mode changes the MM912F634 analog die into reset mode while the voltage regulator is turned back on.

The selection of the different modes is controlled by the Mode Control Register (MCR).

Figure 16 describes how transitions are done between the different operating modes.

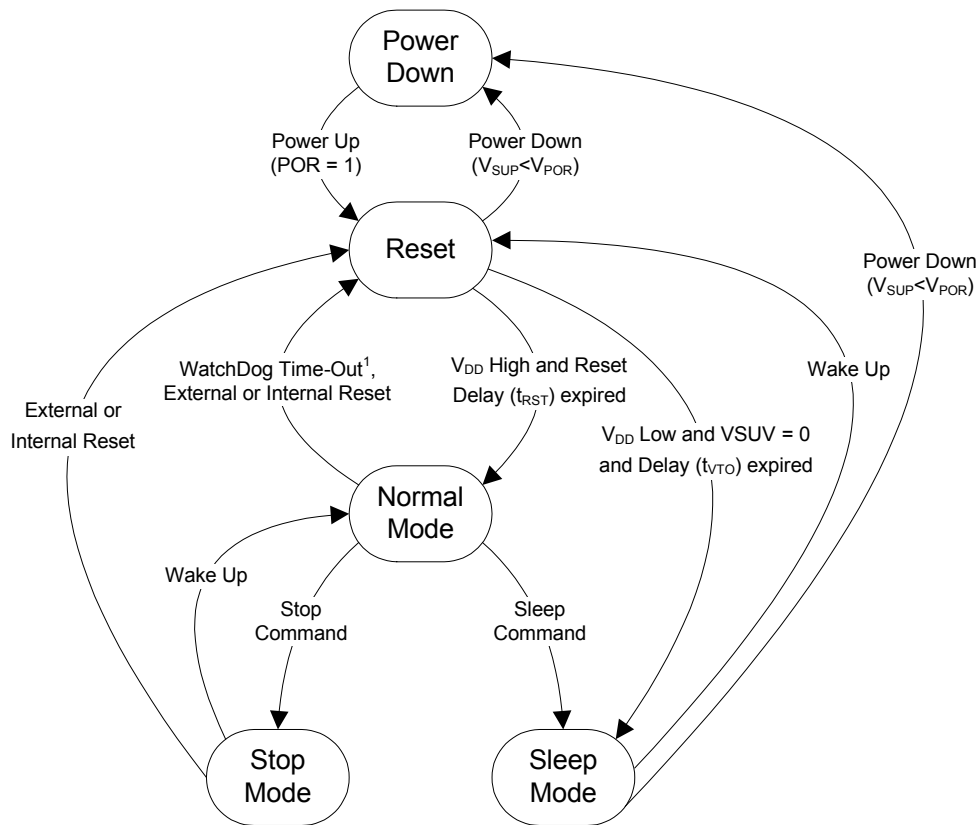

<sup>1)</sup> Initial WD to be served within  $t_{WDTO}$  to enable Window WD

**Figure 16. Modes of Operation and Transitions**

### 4.3.1 Power Down Mode

For the device power ( $VS1$ ) below  $V_{POR}$ , the MM912F634 analog die is virtually in Power Down mode. Once  $VS1 > V_{POR}$ , the MM912F634 analog die enters Reset mode with the condition “Power On Reset - POR”.

### 4.3.2 Reset Mode

The MM912F634 analog die enters Reset mode if a reset condition occurs (POR - Power On Reset, LVR - Low Voltage Reset, Low Voltage VDDX Reset - LVRX, WDR - Watchdog Reset, EXR - External Reset, and WUR - Wake-up Sleep Reset).

For internal reset sources, the  $\overline{RESET\_A}$  pin is driven low for  $t_{RST}$  after the reset condition is gone. After this delay, the  $\overline{RESET\_A}$  pin is released. With a high detected on the  $\overline{RESET\_A}$  pin,  $V_{DD} > V_{LVR}$  and  $V_{DDX} > V_{LVRX}$  the MM912F634 analog die enters in Normal mode.

To avoid short-circuit conditions being present for a long time, a  $t_{VTO}$  timeout is implemented. Once  $V_{DD} < V_{LVR}$  or  $V_{DDX} < V_{LVRX}$  with  $VS1 > (V_{LVRI} + V_{LVR\_H})$  for more than  $t_{VTO}$ , the MM912F634 analog die transitions directly to Sleep mode.

The Reset Status Register (RSR) indicates the source of the reset by individual flags.

- POR - Power On Reset
- LVR - Low Voltage Reset VDD
- LVRX - Low Voltage Reset VDDX
- WDR - Watchdog Reset
- EXR - External Reset
- WUR - Wake-up Sleep Reset

See also [Section 4.7, "Resets"](#).

### 4.3.3 Normal Mode

In Normal mode, all MM912F634 analog die user functions are active and can be controlled by the D2D Interface. Both regulators (VDD and VDDX) are active and operate with full current capability.

Once entered in Normal mode, the Watchdog operates as a simple non-window watchdog with an initial timeout ( $t_{IWDTO}$ ) to be reset via the D2D Interface. After the initial reset, the watchdog operates in standard window mode. See [Section 4.9, "Window Watchdog"](#) for details.

### 4.3.4 Stop Mode

#### NOTE

To avoid any pending analog die interrupts prevent the MCU from entering MCU stop resulting in unexpected system behavior, the analog die IRQ sources should be disabled and the corresponding flags be cleared before entering stop.

The Stop mode allows reduced current consumption with fast startup time. In this mode, both voltage regulators (VDD and VDDX) are active, with limited current drive capability. In this condition, the MCU is supposed to operate in Low Power mode (STOP or WAIT).

The device can enter in Stop mode by configuring the Mode Control Register (MCR) via the D2D Interface. The MCU has to enter a Low Power mode immediately afterwards executing the STOP or WAIT instruction. The Wake-up Source Register (WSR) has to be read after a wake-up condition in order to execute a new STOP mode command. Two base clock cycles ( $f_{BASE}$ ) delay are required between WSR read and MCR write.

While in Stop mode, the MM912F634 analog die wakes up on the following sources:

- Lx - Wake-up (maskable with selectable cyclic sense)
- Forced Wake-up (configurable timeout)
- LIN Wake-up
- D2D Wake-up (special command)

After Wake-up from the sources listed above, the device transitions to Normal mode.

Reset wakes up the device directly to Reset mode.

See [Section 4.8, "Wake-up / Cyclic Sense"](#) for details.

### 4.3.5 Sleep Mode

The Sleep mode allows very low current consumption. In this mode, both voltage regulators (VDD and VDDX) are inactive.

The device can enter into Sleep mode by configuring the Mode Control Register (MCR) via the D2D- Interface. During Sleep mode, all unused internal blocks are deactivated to allow the lowest possible consumption. Power consumption decreases further if the Cyclic Sense or Forced Wake-up feature are disabled. While in Sleep mode, the MM912F634 analog die wakes up on the following sources:

- Lx - Wake-up (maskable with selectable cyclic sense)
- Forced Wake-up (configurable timeout)
- LIN Wake-up

After Wake-up from the sources listed above or a reset condition, the device transitions to Reset mode.

See [Section 4.8, "Wake-up / Cyclic Sense"](#) for details.

### 4.3.6 Analog Die Functionality by Operation Mode

**Table 71. Operation Mode Overview**

Function	Reset	Normal	Stop	Sleep
VDD/VDDX	full	full	stop	OFF
HSUP	OFF	full	OFF	OFF
LSx		full	OFF	OFF
HSx		full	Cyclic Sense <sup>(66)</sup>	Cyclic Sense <sup>(66)</sup>
ADC		full	OFF	OFF
D2D		full	functional	OFF
Lx		full	Wake-up <sup>(66)</sup>	Wake-up <sup>(66)</sup>
PTBx		full	OFF	OFF
LIN		full	Wake-up <sup>(66)</sup>	Wake-up <sup>(66)</sup>
Watchdog		full <sup>(67)</sup>	OFF	OFF
VSENSE		full	OFF	OFF
CSENSE		full	OFF	OFF
Cyclic Sense		not active	Cyclic Sense <sup>(66)</sup>	Cyclic Sense <sup>(66)</sup>

Note:

66. If configured.

67. Special init through non window watchdog.

### 4.3.7 Register Definition

#### 4.3.7.1 Mode Control Register (MCR)

**Table 72. Mode Control Register (MCR)**

Offset <sup>(1)</sup> 0x16							Access: User read/write	
	7	6	5	4	3	2	1	0
R	0	0	0	0	0	0	MODE	
W								
Reset	0	0	0	0	0	0	0	0

Offset related to 0x0200 for blocking access and 0x300 for non blocking access within the global address space.

**Table 73. MCR - Register Field Descriptions**

Field	Description
1-0 MODE	Mode Select - These bits issue a transition from to the selected Operating mode. 00 - Normal mode. Only with effect in Stop Mode. Issues a wake-up and transition to Normal mode. 01 - Stop mode. Initiates a transition to Stop mode. <sup>(68)</sup> 10 - Sleep mode. Initiates transition to Sleep mode. 11 - Normal mode.

Note:

 68. The Wake-up Source Register (WSR) has to be read after a wake-up condition in order to execute a new STOP mode command. Two base clock cycles ( $f_{BASE}$ ) delay are required between WSR read and MCR write.

## 4.4 Power Supply

The MM912F634 analog die supplies VDD (2.5 V), VDDX (5.0 V), and HSUP, based on the supply voltage applied to the VS1 pin. VDD is cascaded of the VDDX regulator. To separate the High-side outputs from the main power supply, the VS2 pin does only power the High-side drivers. Both supply pins have to be externally protected against reverse battery conditions. To supply external Hall Effect Sensors, the HSUP pin supplies a switchable regulated supply. See [Section 4.10, "Hall Sensor Supply Output - HSUP"](#).

A reverse battery protected input (VSENSE) is implemented to measure the Battery Voltage directly. A serial resistor (RVSENSE) is required on this pin. See [Section 4.22, "Supply Voltage Sense - VSENSE"](#). In addition, the VS1 supply can be routed to the ADC (VS1SENSE) to measure the VS1 pin voltage directly. See [Section 4.23, "Internal Supply Voltage Sense - VS1SENSE"](#).

To have an independent ADC verification, the internal sleep mode bandgap voltage can be routed to the ADC (BANDGAP). As this node is independent from the ADC reference, any out of range result would indicate malfunctioning ADC or Bandgap reference. See [Section 4.24, "Internal Bandgap Reference Voltage Sense - BANDGAP"](#).

To stabilize the internal ADC reference voltage for higher precision measurements, the current limited ADC2p5 pin needs to be connected to an external filter capacitor ( $C_{ADC2p5}$ ). It is not recommended to connect additional loads to this pin. See [Section 4.19, "Analog Digital Converter - ADC"](#).

The following safety features are implemented:

- LBI - Low Battery Interrupt, internally measured at VSENSE
- LVI - Low Voltage Interrupt, internally measured at VS1
- HVI - High Voltage Interrupt, internally measured at VS2
- VROVI - Voltage Regulator Overvoltage Interrupt internally measured at VDD and VDDX
- LVR - Low Voltage Reset, internally measured at VDD
- LVRX - Low Voltage Reset, internally measured at VDDX
- HTI - High Temperature Interrupt measured between the VDD and VDDX regulators
- Overtemperature Shutdown measured between the VDD and VDDX regulators

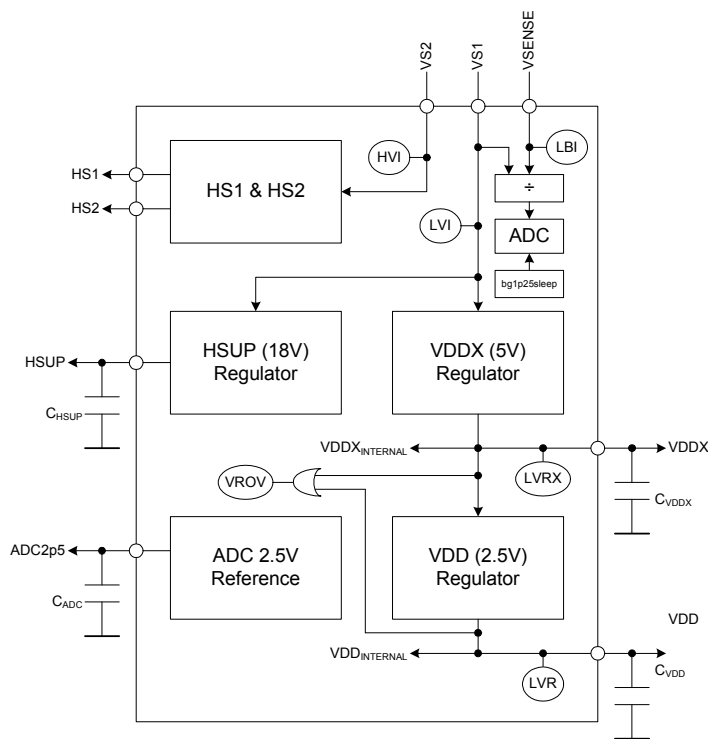

**Figure 17. MM912F634 Power Supply**

#### 4.4.1 Voltage Regulators VDD (2.5 V) & VDDX (5.0 V)

To supply the MCU die and minor additional loads two cascaded voltage regulators have been implemented, VDDX (5.0 V) and VDD (2.5 V). External capacitors ( $C_{VDD}$ ) and ( $C_{VDDX}$ ) are required for proper regulation.

#### 4.4.2 Power Up Behavior / Power Down Behavior

To guarantee safe power up and down behavior, special dependencies are implemented to prevent unwanted MCU execution.

Figure 18 shows a standard power up and power down sequence.

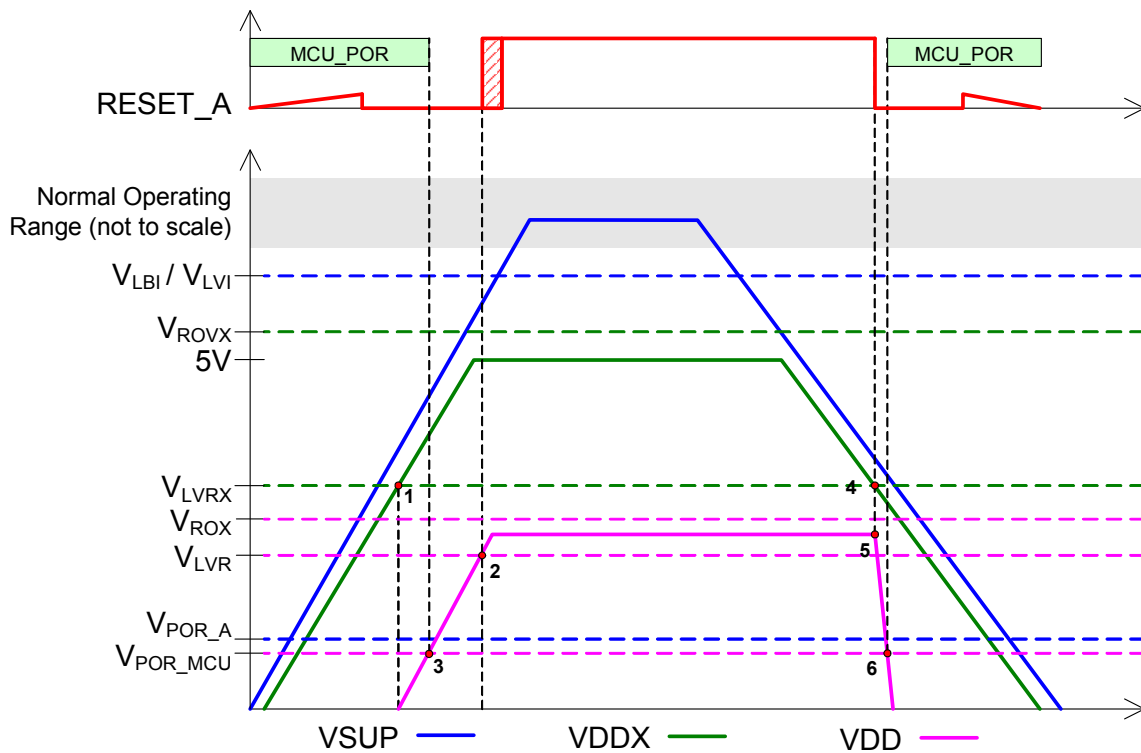

Figure 18. Power-up / Down Sequence

To avoid any abnormal device behavior, it is essential to have the MCU Power on Reset (POR) block complete its start-up sequence before the analog die reset signal ( $\overline{\text{RESET A}}$ ) is asserted. Since the  $\overline{\text{RESET A}}$  circuitry is supplied by  $V_{DDX}$ , the voltage on the 2.5 V supply ( $V_{DD}$ ) needs to remain below the POR threshold whenever  $V_{DDX}$  is too low to guarantee  $\overline{\text{RESET A}}$  can be properly asserted (3;6). This is achieved with the following implementation.

##### Power-up:

- The VDD regulator is enabled after VDDX has reached the  $V_{LVRX}$  threshold (1).
- Once VDD reaches  $V_{LVR}$ , the  $\overline{\text{RESET A}}$  is released (2).

##### Power-down:

- Once VDDX has reached the  $V_{LVRX}$  threshold (4), the VDD regulator is disabled and the regulator output is actively pulled down to discharge any VDD capacitance (5).  $\overline{\text{RESET A}}$  is activated as well.
- The active discharge guarantees VDD to be below POR level before VDDX discharges below critical level for the reset circuitry.

### 4.4.3 Register Definition

#### 4.4.3.1 Voltage Control Register (VCR)

**Table 74. Voltage Control Register (VCR)**

Offset <sup>(69)</sup>	0x04							Access: User read/write
	7	6	5	4	3	2	1	0
R	0	0	0	VROVIE	HTIE	HVIE	LVIE	LBIE
W								
Reset	0	0	0	0	0	0	0	0

Note:

69. Offset related to 0x0200 for blocking access and 0x300 for non blocking access within the global address space.

**Table 75. VCR - Register Field Descriptions**

Field	Description
4 VROVIE	Voltage Regulator Overvoltage Interrupt Enable — Enables the interrupt for the Regulator Overvoltage Condition. 0 - Voltage Regulator Overvoltage Interrupt is disabled 1 - Voltage Regulator Overvoltage Interrupt is enabled
3 HTIE	High Temperature Interrupt Enable — Enables the interrupt for the Voltage Regulator (VDD/VDDX) Temperature Warning. 0 - High Temperature Interrupt is disabled 1 - High Temperature Interrupt is enabled
2 HVIE	High Voltage Interrupt Enable — Enables the interrupt for the VS2 - High Voltage Warning. 0 - High Voltage Interrupt is disabled 1 - High Voltage Interrupt is enabled
1 LVIE	Low Voltage Interrupt Enable — Enables the interrupt for the VS1 - Low Voltage Warning. 0 - Low Voltage Interrupt is disabled 1 - Low Voltage Interrupt is enabled
0 LBIE	Low Battery Interrupt Enable — Enables the interrupt for the VSENSE - Low Battery Voltage Warning. 0 - Low Battery Interrupt is disabled 1 - Low Battery Interrupt is enabled

#### 4.4.3.2 Voltage Status Register (VSR)

**Table 76. Voltage Status Register (VSR)**

Offset <sup>(70)</sup>	0x05							Access: User read
	7	6	5	4	3	2	1	0
R	0	0	0	VROVC	HTC	HVC	LVC	LBC
W								
Reset	0	0	0	0	0	0	0	0

Note:

70. Offset related to 0x0200 for blocking access and 0x300 for non blocking access within the global address space.

**Table 77. VSR - Register Field Descriptions**

Field	Description
4 VROVC	Voltage Regulator Overvoltage Condition - This status bit indicates an overvoltage warning is present for at least one of the main voltage regulators (VDD or VDDX). Reading the register clears the VROVI flag if present. See <a href="#">Section 4.6, "Interrupts"</a> for details. Note: This feature requires the trimming of <a href="#">Section 4.25.2.3, "Trimming Register 2 (CTR2)"</a> to be done to be effective. Untrimmed devices may issue the VROVC condition including the LS turn off at normal operation. 0 - No Voltage Regulator Overvoltage Condition present. 1 - Voltage Regulator Overvoltage Condition present.
3 HTC	High Temperature Condition - This status bit indicates a high temperature warning is present for the Voltage regulators (VDD/VDDX). Reading the register clears the HTI flag if present. See <a href="#">Section 4.6, "Interrupts"</a> for details. 0 - No High Temperature Condition present. 1 - High Temperature Condition present.
2 HVC	High Voltage Condition - This status bit indicates a high voltage warning for VS2 is present. Reading the register clears the HVI flag if present. See <a href="#">Section 4.6, "Interrupts"</a> for details. 0 - No High Voltage Condition present. 1 - High Voltage Condition present.
1 LVC	Low Voltage Condition - This status bit indicates a low voltage warning for VS1 is present. Reading the register clears the LVI flag if present. See <a href="#">Section 4.6, "Interrupts"</a> for details. 0 - No Low Voltage Condition present. 1 - Low Voltage Condition present.
0 LBC	Low Battery Condition - This status bit indicates a low voltage warning for VSENSE is present. Reading the register clears the LBI flag if present. See <a href="#">Section 4.6, "Interrupts"</a> for details. 0 - No Low Battery Condition present. 1 - Low Battery Condition present.

## 4.5 Die to Die Interface - Target

The D2D Interface is the bus interface to the Microcontroller. Access to the MM912F634 analog die is controlled by the D2D Interface module. This section describes the functionality of the die-to-die target block (D2D).

### 4.5.1 Overview

The D2D is the target for a data transfer from the target to the initiator (MCU). The initiator provides a set of configuration registers and two memory mapped 256 Byte address windows. When writing to a window, a transaction is initiated sending a write command, followed by an 8-bit address, and the data byte or word is received from the initiator. When reading from a window, a transaction is received with the read command, followed by an 8-bit address. The target then responds with the data. The basic idea is that a peripheral located on the MM912F634 analog die, can be addressed like an on-chip peripheral.

Features:

- software transparent register access to peripherals on the MM912F634 analog die
- 256 Byte address window
- supports blocking read or write, as well as non-blocking write transactions
- 4 bit physical bus width
- automatic synchronization of the target when initiator starts driving the interface clock
- generates transaction and error status as well as EOT acknowledge
- providing single interrupt interface to D2D Initiator

**4.5.2 Low Power Mode Operation**

The D2D module is disabled in SLEEP mode. In Stop mode, the D2DINT signal is used to wake-up a powered down MCU. As the MCU could wake up without the MM912F634 analog die, a special command is recognized as a wake-up event during Stop mode. See Section 4.3, "Modes of Operation".

**4.5.2.1 Normal Mode / Stop Mode**

**NOTE**

The maximum allowed clock speed of the interface is limited to  $f_{D2D}$ .

While in Normal or Stop mode, D2DCLK acts as input only with pull present. D2D[3:0] operates as an input/output with pull-down always present. D2DINT acts as output only.

**4.5.2.2 Sleep Mode**

While in Sleep mode, all Interface data pins are pulled down to DGND to reduce power consumption.

**4.6 Interrupts**

Interrupts are used to signal a microcontroller that a peripheral needs to be serviced. While in Stop mode, the interrupt signal is used to signal Wake-up events. The interrupts are signaled by an active high level of the D2DINT pin, which remains high until the interrupt is acknowledged via the D2D-Interface. Interrupts are only asserted while in Normal mode.

**4.6.1 Interrupt Source Identification**

Once an Interrupt is signaled, there are two options to identify the corresponding source(s).

**4.6.1.1 Interrupt Source Mirror**

**NOTE**

The VSI - Voltage Status Interrupt combines the five status flags for the Low Battery Interrupt, Low Voltage Interrupt, High Voltage Interrupt, Voltage Regulator Overvoltage Interrupt, and the Voltage Regulator High Temperature Interrupt. The specific source can be identified by reading the Voltage Status Register - VSR.

All Interrupt sources in MM912F634 analog die are mirrored to a special Interrupt Source Register (ISR). This register is read only and indicates all currently pending Interrupts. Reading this register does not acknowledge any interrupt. An additional D2D access is necessary to serve the specific module.

**4.6.1.1.1 Interrupt Source Register (ISR)**

**Table 78. Interrupt Source Register (ISR)**

Offset <sup>(71)</sup>	0x00 (0x00 and 0x01 for 8Bit access)														Access: User read	
	15	14	13	12	11	10	9	8	7	6	5	4	3	2	1	0
R	0	0	HOT	LSOT	HSOT	LINOT	SCI	RX	TX	ERR	TOV	CH3	CH2	CH1	CH0	VSI
W																

Note:

71. Offset related to 0x0200 for blocking access and 0x300 for non blocking access within the global address space.

**Table 79. ISR - Register Field Descriptions**

Field	Description
0 - VSI	VSI - Voltage Status Interrupt combining the following sources: <ul style="list-style-type: none"> <li>• Low Battery Interrupt</li> <li>• Low Voltage Interrupt</li> <li>• High Voltage Interrupt</li> <li>• Voltage Regulator Overvoltage Interrupt</li> <li>• Voltage Regulator High Temperature Interrupt</li> </ul>
1 - CH0	CH0 - TIM Channel 0 Interrupt
2 - CH1	CH1 - TIM Channel 1 Interrupt
3 - CH2	CH2 - TIM Channel 2 Interrupt
4 - CH3	CH3 - TIM Channel 3 Interrupt
5 - TOV	TOV - Timer Overflow Interrupt
6 - ERR	ERR - SCI Error Interrupt
7 - TX	TX - SCI Transmit Interrupt
8 - RX	RX - SCI Receive Interrupt
9 - SCI	SCI - ADC Sequence Complete Interrupt
10 - LINOT	LINOT - LIN Driver Overtemperature Interrupt
11 - HSOT	HSOT - High-side Overtemperature Interrupt
12 - LSOT	LSOT - Low-side Overtemperature Interrupt
13 - HOT	HOT - HSUP Overtemperature Interrupt

#### 4.6.1.2 Interrupt Vector Emulation by Priority

To allow a vector based interrupt handling by the MCU, the number of the highest prioritized interrupt pending is returned in the Interrupt Vector Register. To allow an offset based vector table, the result is pre-shifted (multiple of 2). Reading this register does not acknowledge an interrupt. An additional D2D access is necessary to serve the specific module.

##### 4.6.1.2.1 Interrupt Vector Register (IVR)

**Table 80. Interrupt Vector Register (IVR)**

Offset <sup>(72)</sup> 0x02								Access: User read
	7	6	5	4	3	2	1	0
R	0	0	IRQ					
W								

Note:

72. Offset related to 0x0200 for blocking access and 0x300 for non blocking access within the global address space.

**Table 81. IVR - Register Field Descriptions**

Field	Description
5:0 IRQ	Represents the highest prioritized interrupt pending. See <a href="#">Table 82</a> In case no interrupt is pending, the result is 0.

The following table is listing all MM912F634 analog die interrupt sources with the corresponding priority.

**Table 82. Interrupt Source Priority**

Interrupt Source	IRQ	Priority
no interrupt pending or wake-up from Stop mode	0x00	1 (highest)
LVI - Low Voltage Interrupt	0x02	2
HTI - Voltage Regulator High Temperature Interrupt	0x04	3
LBI - Low Battery Interrupt	0x06	4
CH0 - TIM Channel 0 Interrupt	0x08	5
CH1 - TIM Channel 1 Interrupt	0x0A	6
CH2 - TIM Channel 2 Interrupt	0x0C	7
CH3 - TIM Channel 3 Interrupt	0x0E	8
TOV - Timer Overflow Interrupt	0x10	9
ERR - SCI Error Interrupt	0x12	10
TX - SCI Transmit Interrupt	0x14	11
RX - SCI Receive Interrupt	0x16	12
SCI - ADC Sequence Complete Interrupt	0x18	13
LINOT - LIN Driver Overtemperature Interrupt	0x1A	14
HSOT - High-side Overtemperature Interrupt	0x1C	15
LSOT - Low-side Overtemperature Interrupt	0x1E	16
HOT - HSUP Overtemperature Interrupt	0x20	17
HVI - High Voltage Interrupt	0x22	18
VROVI - Voltage Regulator Overvoltage Interrupt	0x24	19 (lowest)

## 4.6.2 Interrupt Sources

### 4.6.2.1 Voltage Status Interrupt (VSI)

The Voltage Status Interrupt - VSI combines the five interrupt sources of the Voltage Status Register. It is only available in the Interrupt Source Register (ISR). Acknowledge the interrupt by reading the Voltage Status Register - VSR. To issue a new interrupt, the condition has to vanish and occur again. See [Section 4.4, "Power Supply"](#) for details on the Voltage Status Register including masking information.

### 4.6.2.2 Low Voltage Interrupt (LVI)

Acknowledge the interrupt by reading the Voltage Status Register - VSR. To issue a new interrupt, the condition has to vanish and occur again. See [Section 4.4, "Power Supply"](#) for details on the Voltage Status Register including masking information.

### 4.6.2.3 Voltage Regulator High Temperature Interrupt (HTI)

Acknowledge the interrupt by reading the Voltage Status Register - VSR. To issue a new interrupt, the condition has to vanish and occur again. See [Section 4.4, "Power Supply"](#) for details on the Voltage Status Register including masking information.

### 4.6.2.4 Low Battery Interrupt (LBI)

Acknowledge the interrupt by reading the Voltage Status Register - VSR. To issue a new interrupt, the condition has to vanish and occur again. See [Section 4.4, "Power Supply"](#) for details on the Voltage Status Register including masking information.

### 4.6.2.5 TIM Channel 0 Interrupt (CH0)

See [Section 4.18, "Basic Timer Module - TIM \(TIM16B4C\)"](#).

#### 4.6.2.6 TIM Channel 1 Interrupt (CH1)

See [Section 4.18, "Basic Timer Module - TIM \(TIM16B4C\)"](#).

#### 4.6.2.7 TIM Channel 2 Interrupt (CH2)

See [Section 4.18, "Basic Timer Module - TIM \(TIM16B4C\)"](#).

#### 4.6.2.8 TIM Channel 3 Interrupt (CH3)

See [Section 4.18, "Basic Timer Module - TIM \(TIM16B4C\)"](#).

#### 4.6.2.9 TIM Timer Overflow Interrupt (TOV)

See [Section 4.18, "Basic Timer Module - TIM \(TIM16B4C\)"](#).

#### 4.6.2.10 SCI Error Interrupt (ERR)

See [Section 4.15, "Serial Communication Interface \(S08SCIV4\)"](#).

#### 4.6.2.11 SCI Transmit Interrupt (TX)

See [Section 4.15, "Serial Communication Interface \(S08SCIV4\)"](#).

#### 4.6.2.12 SCI Receive Interrupt (RX)

See [Section 4.15, "Serial Communication Interface \(S08SCIV4\)"](#).

#### 4.6.2.13 LIN Driver Overtemperature Interrupt (LINOT)

Acknowledge the interrupt by reading the LIN Register - LINR. To issue a new interrupt, the condition has to vanish and occur again. See [Section 4.14, "LIN Physical Layer Interface - LIN"](#) for details on the LIN Register including masking information.

#### 4.6.2.14 High-side Overtemperature Interrupt (HSOT)

Acknowledge the interrupt by reading the High-side Status Register - HSSR. To issue a new interrupt, the condition has to vanish and occur again. See [Section 4.11, "High-side Drivers - HS"](#) for details on the High-side Status Register including masking information.

#### 4.6.2.15 Low-side Overtemperature Interrupt (LSOT)

Acknowledge the interrupt by reading the Low-side Status Register - LSSR. To issue a new interrupt, the condition has to vanish and occur again. See [Section 4.12, "Low-side Drivers - LSx"](#) for details on the Low-side Status Register including masking information.

#### 4.6.2.16 HSUP Overtemperature Interrupt (HOT)

Acknowledge the interrupt by reading the Hall Supply Register - HSR. To issue a new interrupt, the condition has to vanish and occur again. See [Section 4.10, "Hall Sensor Supply Output - HSUP"](#) for details on the Hall Supply Register including masking information.

#### 4.6.2.17 High Voltage Interrupt (HVI)

Acknowledge the interrupt by reading the Voltage Status Register - VSR. To issue a new interrupt, the condition has to vanish and occur again. See [Section 4.4, "Power Supply"](#) for details on the Voltage Status Register including masking information.

#### 4.6.2.18 Voltage Regulator Overvoltage Interrupt (VROVI)

Acknowledge the interrupt by reading the Voltage Status Register - VSR. To issue a new interrupt, the condition has to vanish and occur again. See [Section 4.4, "Power Supply"](#) for details on the Voltage Status Register including masking information.

## 4.7 Resets

To protect the system during critical events, the MM912F634 analog die drives the  $\overline{\text{RESET\_A}}$  pin low during the presence of the reset condition. In addition, the  $\overline{\text{RESET\_A}}$  pin is monitored for external reset events. To match the MCU, the  $\overline{\text{RESET\_A}}$  pin is based on the VDDX voltage level.

After an internal reset condition has gone, the  $\overline{\text{RESET\_A}}$  stays low for an additional time  $t_{\text{RST}}$  before being released. Entering reset mode causes all MM912F634 analog die registers to be initialized to their RESET default. The only registers with valid information are the Reset Status Register (RSR) and the Wake-up Source Register (WUS).

### 4.7.1 Reset Sources

In the MM912F634 six reset sources exist.

#### 4.7.1.1 POR - Analog Die Power On Reset

To indicate the device power supply (VS1) was below  $V_{\text{POR}}$  or the MM912F634 analog die was powered up, the POR condition is set. See Section 4.3, "Modes of Operation".

#### 4.7.1.2 LVR - Low Voltage Reset - VDD

With the VDD voltage regulator output voltage falling below  $V_{\text{LVR}}$ , the Low Voltage Reset condition becomes present. As the VDD Regulator is shutdown once a LVRX condition is detected, The actual cause could be also a low voltage condition at the VDDX regulator. See Section 4.4, "Power Supply".

#### 4.7.1.3 LVRX - Low Voltage Reset - VDDX

With the VDDX voltage regulator output voltage falling below  $V_{\text{LVRX}}$ , the Low Voltage Reset condition becomes present. See Section 4.4, "Power Supply".

#### 4.7.1.4 WUR - Wake-up Reset

While in Sleep mode, any active wake-up event causes a MM912F634 analog die transition from Sleep to Reset Mode. To determine the wake-up source, refer to Section 4.8, "Wake-up / Cyclic Sense".

#### 4.7.1.5 EXR - External Reset

Any low level voltage at the  $\overline{\text{RESET\_A}}$  pin with a duration  $> t_{\text{RSTDF}}$  issues an External Reset event. This reset source is also active in Stop mode.

#### 4.7.1.6 WDR - Watchdog Reset

Any incorrect serving if the MM912F634 analog die Watchdog results in a Watchdog Reset. Refer to the Section 4.9, "Window Watchdog" for details.

### 4.7.2 Register Definition

#### 4.7.2.1 Reset Status Register (RSR)

Table 83. Reset Status Register (RSR)

Offset <sup>(73)</sup> 0x15		Access: User read						
	7	6	5	4	3	2	1	0
R	0	0	WDR	EXR	WUR	LVRX	LVR	POR
W								

Note:

73. Offset related to 0x0200 for blocking access and 0x300 for non blocking access within the global address space.

**Table 84. RSR - Register Field Descriptions**

Field	Description
5 - WDR	Watchdog Reset - Reset caused by an incorrect serving of the watchdog.
4 - EXR	External Reset - Reset caused by the RESET_A pin driven low externally for $> t_{RSTDF}$
3 - WUR	Wake-up Reset - Reset caused by a wake-up from Sleep mode. To determine the wake-up source, refer to <a href="#">Section 4.8, "Wake-up / Cyclic Sense"</a> .
2 - LVRX	Low Voltage Reset VDDX - Reset caused by a low voltage condition monitored at the VDDX output.
1 - LVR	Low Voltage Reset VDD - Reset caused by a low voltage condition monitored at the VDD output. <sup>(74)</sup>
0 - POR	Power On Reset - Supply Voltage was below $V_{POR}$ .

Note:

74. As the VDD Regulator is shutdown once a LVRX condition is detected, The actual cause could be also a low voltage condition at the VDDX regulator.

Reading the Reset Status register clears the information inside. Writing has no effect. LVR and LVRX are masked when POR or WUR are set.

## 4.8 Wake-up / Cyclic Sense

To wake-up the MM912F634 analog die from Stop or Sleep mode, several wake-up sources are implemented. As described in [Section 4.3, "Modes of Operation"](#), a wake-up from Stop mode results in an interrupt (D2DINT) to the MCU combined with a transition to Normal mode. A wake-up from Sleep mode results in a transition to Reset mode. In any case, the source of the wake-up can be identified by reading the Wake-up Source Register (WSR). The Wake-up Source Register (WSR) has to be read after a wake-up condition in order to execute a new STOP mode command. Two base clock cycles ( $f_{BASE}$ ) delay are required between the WSR read and MCR write.

In general, there are the following seven main wake-up sources:

- Wake-up by a state change of one of the Lx inputs
- Wake-up by a state change of one of the Lx inputs during a cyclic sense
- Wake-up due to a forced wake-up
- Wake-up by the LIN module
- Wake-up by D2D interface (Stop mode only)
- Wake-up due to internal / external Reset (Stop mode only)
- Wake-up due to loss of supply voltage (Sleep mode only)

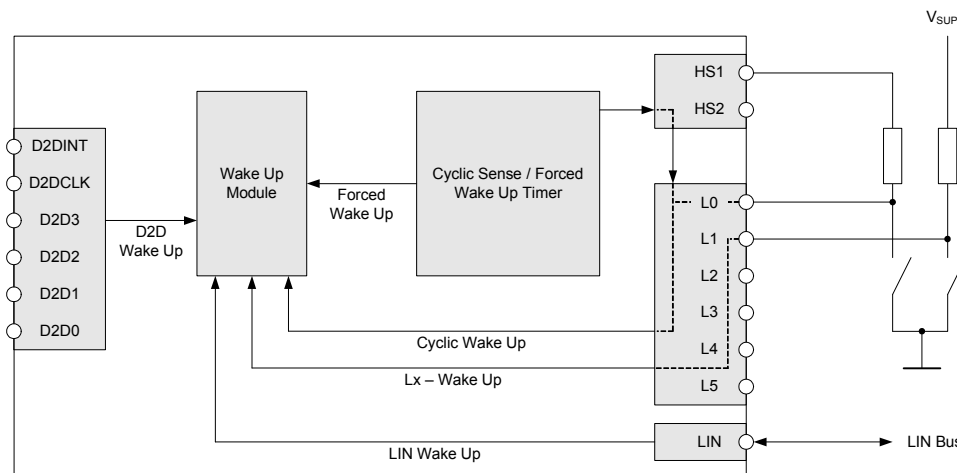
**Figure 19. Wake-up Sources**

## 4.8.1 Wake-up Sources

### 4.8.1.1 Lx - Wake-up (Cyclic Sense Disabled)

Any state digital change on a Wake-up Enabled Lx input issues a wake-up. In order to select and activate a Wake-up Input (Lx), the Wake-up Control Register (WCR) must be configured with appropriate LxWE inputs enabled or disabled before entering low power mode. The Lx - Wake-up may be combined with the Forced Wake-up.

Note: Selecting a Lx Input for wake-up disables a selected analog input once entering low power mode.

### 4.8.1.2 Lx - Cyclic Sense Wake-up

#### NOTE

Once Cyclic Sense is configured (CSSEL!=0), the state change is only recognized from one cyclic sense event to the next.

The additional accuracy of the cyclic sense cycle by the WD clock trimming is only active during STOP mode. There is no trimmed clock available during SLEEP mode.

To reduce external power consumption during low power mode a cyclic wake-up has been implemented. Configuring the Timing Control Register (TCR) a specific cycle time can be selected to implement a periodic switching of the HS1 or HS2 output with the corresponding detection of an Lx state change. Any configuration of the HSx in the High-side Control Register (HSCR) is ignored when entering low power mode. The Lx - Cyclic Sense Wake-up may be combined with the Forced Wake-up. In case both (forced and Lx change) events are present at the same time, the Forced Wake-up is indicated as Wake-up source.

### 4.8.1.3 Forced Wake-up

Configuring the Forced Wake-up Multiplier (FWM) in the Timing Control Register (TCR) enables the forced wake-up based on the selected Cyclic Sense Timing (CST). Forced Wake-up can be combined with all other wake-up sources considering the timing dependencies.

### 4.8.1.4 LIN - Wake-up

While in Low-Power mode the MM912F634 analog die monitors the activity on the LIN bus. A dominant pulse longer than  $t_{PROPWL}$  followed by a dominant to recessive transition causes a LIN Wake-up. This behavior protects the system from a short-to-ground bus condition.

### 4.8.1.5 D2D - Wake-up (Stop Mode Only)

Receiving a Normal mode request via the D2D interface (MODE=0, Mode Control Register (MCR)) results in a wake-up from stop mode. As this condition is controlled by the MCU, no wake-up status bit does indicate this wake-up source.

### 4.8.1.6 Wake-up Due to Internal / External Reset (STOP Mode Only)

While in Stop mode, a Reset due to a VDD low voltage condition or an external Reset applied on the  $\overline{\text{RESET\_A}}$  pin results in a Wake-up with immediate transition to Reset mode. In this case, the LVR or EXR bits in the Reset Status Register indicates the source of the event.

### 4.8.1.7 Wake-up Due to Loss of Supply Voltage (SLEEP Mode Only)

While in Sleep mode, a supply voltage  $VS1 < V_{POR}$  results in a transition to Power On mode.

## 4.8.2 Register Definition

### 4.8.2.1 Wake-up Control Register (WCR)

**Table 85. Wake-up Control Register (WCR)**

Offset <sup>(75)</sup> 0x12		Access: User read/write						
	7	6	5	4	3	2	1	0
R	CSSEL		L5WE	L4WE	L3WE	L2WE	L1WE	LOWE
W	CSSEL		L5WE	L4WE	L3WE	L2WE	L1WE	LOWE
Reset	0	0	1	1	1	1	1	1

Note:

75. Offset related to 0x0200 for blocking access and 0x300 for non blocking access within the global address space.

**Table 86. WCR - Register Field Descriptions**

Field	Description
7-6 CSSEL	Cyclic Sense Select - Configures the HSx output for the cyclic sense event. Note, with no LxWE selected - only the selected HSx output is switched periodically, no Lx state change would be detected. For all configurations, the Forced Wake-up can be activated in parallel in <a href="#">Section 4.8.2.2, "Timing Control Register (TCR)"</a> 00 - Cyclic Sense Off 01 - Cyclic Sense with periodic HS1on 10 - Cyclic Sense with periodic HS2 on 11 - Cyclic Sense with periodic HS1 and HS2 on.
5 - L5WE	Wake-up Input 5 Enabled - L5 Wake-up Select Bit. 0 - L5 Wake-up Disabled 1 - L5 Wake-up Enabled
4 - L4WE	Wake-up Input 4 Enabled - L4 Wake-up Select Bit. 0 - L4 Wake-up Disabled 1 - L4 Wake-up Enabled
3 - L3WE	Wake-up Input 3 Enabled - L3 Wake-up Select Bit. 0 - L3Wake-up Disabled 1 - L3 Wake-up Enabled
2- L2WE	Wake-up Input 2 Enabled - L2 Wake-up Select Bit. 0 - L2 Wake-up Disabled 1 - L2 Wake-up Enabled
1 - L1WE	Wake-up Input 1 Enabled - L1 Wake-up Select Bit. 0 - L1 Wake-up Disabled 1 - L1 Wake-up Enabled
0 - LOWE	Wake-up Input 0 Enabled - L0 Wake-up Select Bit. 0 - L0 Wake-up Disabled 1 - L0 Wake-up Enabled

### 4.8.2.2 Timing Control Register (TCR)

**Table 87. Timing Control Register (TCR)**

Offset <sup>(76)</sup> 0x13		Access: User read/write						
	7	6	5	4	3	2	1	0
R	FWM				CST			
W	FWM				CST			
Reset	0	0	0	0	0	0	0	0

Note:

76. Offset related to 0x0200 for blocking access and 0x300 for non blocking access within the global address space.

**Table 88. TCR - Register Field Descriptions**

Field	Description
7-4 FWM	Forced Wake-up Multiplier - Configures the multiplier for the forced wake-up. The selected multiplier (FWM!=0) forces a wake-up every FWM x CST ms. With this implementation, Forced and Cyclic wake-up can be performed in parallel with the cyclic sense period <= the forced wake-up period. 0000 - Forced Wake-up = Off 0001 - 1x 0010 - 2x 0011 - 4x 0100 - 8x 0101 - 16x 0110 - 32x 0111 - 64x 1000 - 128x 1001 - 256x 1010 - 512x 1011 - 1024x 11xx - not implemented (Forced Wake Multiplier = 1024x)
3-0 CST	Cyclic Sense Timing <sup>(77)</sup> - 0000 - 1.0 ms 0001 - 2.0 ms 0010 - 5.0 ms 0011 - 10 ms 0100 - 20 ms 0101 - 50 ms 0110 - 100 ms 0111 - 200 ms 1000 - 500 ms 1001 - 1000 ms 1010 - 1111 - not implemented (Cyclic Sense Timing = 1000 ms)

Note:

77. Cyclic Sense Timing with Accuracy CS<sub>AC</sub> and CS<sub>ACT</sub>.

**4.8.2.3 Wake-up Source Register (WSR)**

**Table 89. Wake-up Source Register (WSR)**

Offset<sup>(78)</sup> 0x14

Access: User read

	7	6	5	4	3	2	1	0
R	FWU	LINWU	L5WU	L4WU	L3WU	L2WU	L1WU	L0WU
W								

Note:

78. Offset related to 0x0200 for blocking access and 0x300 for non blocking access within the global address space.

**Table 90. WSR - Register Field Descriptions**

Field	Description
7 - FWU	Forced Wake-up - Wake-up caused by a forced wake-up
6 - LINWU	LIN Wake-up - Wake-up caused by a LIN wake-up
5 - L5WU	L5 Wake-up - Wake-up caused by a state change of the L6 Input
4 - L4WU	L4 Wake-up - Wake-up caused by a state change of the L5 Input
3 - L3WU	L3 Wake-up - Wake-up caused by a state change of the L4 Input
2 - L2WU	L2 Wake-up - Wake-up caused by a state change of the L3 Input
1 - L1WU	L1 Wake-up - Wake-up caused by a state change of the L2 Input
0 - L0WU	L0 Wake-up - Wake-up caused by a state change of the L1 Input

Reading the WSR clears the wake-up status bit(s). Writing has no effect. The Wake-up Source Register (WSR) has to be read after a wake-up condition, in order to execute a new STOP mode command. Two base clock cycles ( $f_{BASE}$ ) delays are required between the WSR read and the MCR write.

## 4.9 Window Watchdog

The MM912F634 analog die includes a configurable window watchdog, which is active in Normal mode. The watchdog module is based on a separate clock source ( $f_{BASE}$ ) operating independent from the MCU based D2DCLK clock. The watchdog timeout ( $t_{WDTO}$ ) can be configured between 10 ms and 1280 ms (typ.) using the Watchdog Register (WDR).

During Low Power mode, the watchdog feature is not active, a D2D read during Stop mode sets the WDOFF bit.

To clear the watchdog counter, an alternating write must be performed to the Watchdog Service Register (WDSR). The first write after the  $\overline{RESET\_A}$  has been released has to be 0xAA. The next one must be 0x55.

After the  $\overline{RESET\_A}$  has been released, there is a standard (non-window) watchdog active with a fixed timeout of  $t_{WDTO}$ . The Watchdog Window Open (WDWO) bit is set during this time and the window watchdog can be configured (WDR) without changing the initial timeout, and can be trimmed using the trim value given in the MCU trimming Flash section. See [Section 4.25, "MM912F634 - Analog Die Trimming"](#).

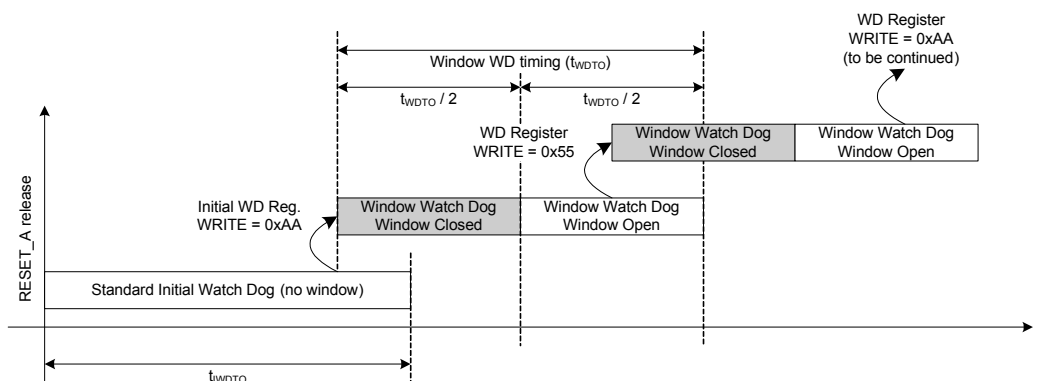

**Figure 20. MM912F634 Analog Die Watchdog Operation**

To enable the window watchdog, the initial counter reset has to be performed by writing 0xAA to the Watchdog Service Register (WDSR) before  $t_{WDTO}$  is reached.

If the  $t_{WDTO}$  timeout is reached with no counter reset or a value different from 0xAA was written to the WDSR, a watchdog reset occurs.

Once entering Window Watchdog mode, the first half of the time  $t_{WDTO}$  forbids a counter reset. To reset the watchdog counter, an alternating write of 0x55 and 0xAA must be performed within the second half of the  $t_{WDTO}$ . A Window Open (WDWO) flag indicates the current status of the window. A timeout or wrong value written to the WDSR forces a watchdog reset.

For debug purpose, the watchdog can be completely disabled by applying  $V_{TST}$  to the TCLK pin while TEST\_A is grounded. The watchdog is disabled as long as  $V_{TST}$  is present. The watchdog is guaranteed functional for  $V_{TSTEN}$ . The WDOFF bit indicates the watchdog being disabled. The WDSR register resets to default once the watchdog is disabled. Once the watchdog is re-enabled, the initial watchdog sequence has to be performed.

During Low Power mode, the Watchdog clock is halted and the Watchdog Service Register (WDSR) is reset to the default state.

## 4.9.1 Register Definition

### 4.9.1.1 Watchdog Register (WDR)

**Table 91. Watchdog Register (WDR)**

Offset <sup>(79)</sup> 0x10		Access: User read/write							
		7	6	5	4	3	2	1	0
R		WDOFF	WDWO	0	0	0	WDTO		
W									
Reset		0	0	0	0	0	0	0	0

Note:

79. Offset related to 0x0200 for blocking access and 0x300 for non blocking access within the global address space.

**Table 92. WDR - Register Field Descriptions**

Field	Description
7 - WDOFF	watchdog Off - Indicating the Watchdog module is being disabled externally.
6 - WDWO	Watchdog Window Open - Indicating the Watchdog Window is currently open for counter reset.
2-0 WDTO[2:0]	Watchdog Timeout Configuration - configuring the Watchdog timeout duration $t_{WDTO}$ . 000 - 10 ms 001 - 20 ms 010 - 40 ms 011 - 80 ms 100 - 160 ms 101 - 320 ms 110 - 640 ms 111 - 1280 ms

### 4.9.1.2 Watchdog Service Register (WDSR)

**Table 93. Watchdog Service Register (WDSR)**

Offset <sup>(80)</sup> 0x11		Access: User read/write							
		7	6	5	4	3	2	1	0
R		WDSR							
W									
Reset		0	1	0	1	0	1	0	1

Note:

80. Offset related to 0x0200 for blocking access and 0x300 for non blocking access within the global address space.

**Table 94. WDSR - Register Field Descriptions**

Field	Description
7-0 WDSR	Watchdog Service Register - Writing this register with the correct value (0xAA alternating 0x55) while the window is open resets the watchdog counter. Writing the register while the watchdog is disabled has no effect.

## 4.10 Hall Sensor Supply Output - HSUP

To supply Hall Effect Sensors or similar external loads, the HSUP output is implemented. To reduce power dissipation inside the device, the output is implemented as a switchable Voltage Regulator, internally connected to the VS1 supply input. For protection, an Overtemperature Shutdown and a Current Limitation is implemented. A write to the Hall Supply Register (HSR), when the overtemperature condition is gone, re-enables the Hall Supply Output. The HSUP output is active only during Normal mode. A capacitor  $C_{HSUP}$  is recommended for operation.

## 4.10.1 Register Definition

### 4.10.1.1 Hall Supply Register (HSR)

**Table 95. Hall Supply Register (HSR)**

Offset <sup>(81)</sup>	0x38							Access: User read/write
	7	6	5	4	3	2	1	0
R	HOTIE	HOTC	0	0	0	0	0	HSUPON
W								
Reset	0	0	0	0	0	0	0	0

Note:

81. Offset related to 0x0200 for blocking access and 0x300 for non blocking access within the global address space.

**Table 96. HSR - Register Field Descriptions**

Field	Description
7 - HOTIE	Hall Supply Overtemperature Interrupt Enable
6 - HOTC	Hall Supply Overtemperature Condition present. During the event, the Hall Supply is shut down. Reading the register clears the HOT flag if present. See <a href="#">Section 4.6, "Interrupts"</a> for details.
0 - HSUPON	Hall Supply On: 0 - Hall Supply Regulator disabled 1 - Hall Supply Regulator enabled

## 4.11 High-side Drivers - HS

These outputs are two High-side drivers, intended to drive small resistive loads or LEDs incorporating the following features:

- PWM capability via the PWM Module
- Open load detection
- Current limitation
- Overtemperature shutdown (with maskable interrupt)
- High voltage shutdown - HVI (software maskable)
- Cyclic-Sense, See [Section 4.8, "Wake-up / Cyclic Sense"](#)

### 4.11.1 Open Load Detection

Each high-side driver signals an Open Load condition if the current through the high-side is below the open load current threshold. The open load condition is indicated with the bits HS1OL and HS2OL in the High-side Status Register (HSSR).

When the High-side is in OFF state, the Open Load Detection function is not operating. When reading the HSSR register while the High-side is operating in PWM and is in the OFF state, the HS1OL and HS2OL bits does not indicate Open Load.

### 4.11.2 Current Limitation

Each high-side driver has an output current limitation. In combination with the overtemperature shutdown the high-side drivers are protected against overcurrent and short-circuit failures. The driver operating in the current limitation area is indicated with the bits HS1CL and HS2CL in the High-side Status Register (HSSR).

### 4.11.3 Overtemperature Protection (HS Interrupt)

Both high-side drivers are protected against overtemperature. In overtemperature conditions, both high-side drivers are shut down and the event is latched in the Interrupt Control Module. The shutdown is indicated as HS Interrupt in the Interrupt Source Register (ISR).

A thermal shutdown of the high-side drivers is indicated by setting the HSOT bit in the High-side Status Register (HSSR). A write to the High-side Control Register (HSCR), when the overtemperature condition is gone, re-enables the high-side drivers.

#### 4.11.4 High Voltage Shutdown

In case of a high voltage condition (HVI), and if the high voltage shutdown is enabled (bit HVSDE in the High-side Control Register (HSCR) is set), both high-side drivers are shut down. A write to the High-side Control Register (HSCR), when the high voltage condition is gone, re-enables the high-side drivers.

#### 4.11.5 Sleep And Stop Mode

The high-side drivers can be enabled to operate in Sleep and Stop mode for cyclic sensing. See [Section 4.8, "Wake-up / Cyclic Sense"](#)

#### 4.11.6 PWM Capability

[Section 4.13, "PWM Control Module \(PWM8B2C\)"](#)

#### 4.11.7 Register Definition

##### 4.11.7.1 High-side Control Register (HSCR)

**Table 97. High-side Control Register (HSCR)**

Offset <sup>(82)</sup> 0x28								Access: User read/write
	7	6	5	4	3	2	1	0
R	HSOTIE	HSHVSDE	PWMCS2	PWMCS1	PWMHS2	PWMHS1	HS2	HS1
W								
Reset	0	0	0	0	0	0	0	0

Note:

82. Offset related to 0x0200 for blocking access and 0x300 for non blocking access within the global address space.

**Table 98. HSCR - Register Field Descriptions**

Field	Description
7 - HSOTIE	High-side Overtemperature Interrupt Enable
6 - HSHVSDE	High-side High Voltage Shutdown. Once enabled, both high-sides shuts down when a high voltage condition - HVC is present. See <a href="#">Section 4.4, "Power Supply"</a> for the Voltage Status Register.
5 - PWMCS2	PWM Channel Select HS2 0 - PWM Channel 0 selected as PWM Channel 1 - PWM Channel 1 selected as PWM Channel
4 - PWMCS1	PWM Channel Select HS1 0 - PWM Channel 0 selected as PWM Channel 1 - PWM Channel 1 selected as PWM Channel
3 - PWMHS2	PWM Enable for HS2 0 - PWM disabled on HS2 1 - PWM enabled on HS2 (Channel as selected with PWMCS2)
2 - PWMHS1	PWM Enable for HS1 0 - PWM disabled on HS1 1 - PWM enabled on HS1 (Channel as selected with PWMCS1)
1 - HS2	HS2 Control 0 - HS2 disabled 1 - HS2 enabled
0 - HS1	HS1 Control 0 - HS1 disabled 1 - HS1 enabled

## 4.11.7.2 High-side Status Register (HSSR)

**Table 99. High-side Status Register (HSSR)**

 Offset<sup>(83)</sup> 0x29

Access: User read

	7	6	5	4	3	2	1	0
R	HSOTC	0	0	0	HS2CL	HS1CL	HS2OL	HS1OL
W								
Reset	0	0	0	0	0	0	0	0

Note:

83. Offset related to 0x0200 for blocking access and 0x300 for non blocking access within the global address space.

**Table 100. HSSR - Register Field Descriptions**

Field	Description
7 - HSOTC	High-side Overtemperature Condition present. Both drivers are turned off. Reading the register clears the HSOT interrupt flag if present. See <a href="#">Section 4.6, "Interrupts"</a> for details.
3 - HS2CL	High-side 2 Current Limitation
2 - HS1CL	High-side 1 Current Limitation
1 - HS2OL	High-side 2 Open Load <sup>(84)</sup>
0 - HS1OL	High-side 1 Open Load <sup>(84)</sup>

Note:

84. When the High-side is in OFF state, the Open Load Detection function is not operating. When reading the HSSR register while the High-side is operating in PWM and is in the OFF state, the HS1OL and HS2OL bits does not indicate Open Load.

## 4.12 Low-side Drivers - LSx

### 4.12.1 Introduction / Features

These outputs are two Low-side drivers intended to drive relays (inductive loads) incorporating the following features:

- PWM capability
- Open load detection
- Current limitation
- Overtemperature shutdown (with maskable interrupt)
- Active clamp
- Independent VREG - High Voltage Shutdown

**4.12.1.1 Block Diagram**

The following Figure shows the basic structure of the LS drivers.

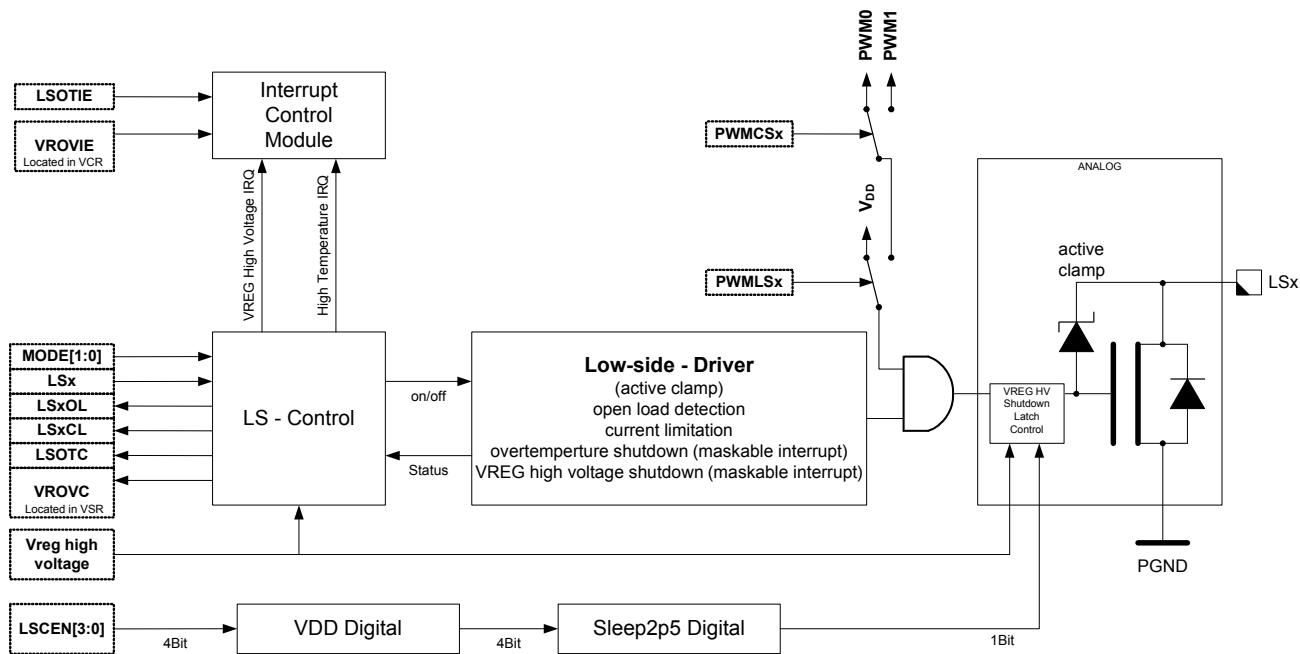

**Figure 21. Low-side Drivers - Block Diagram**

**4.12.1.2 Modes of Operation**

The Low-side module is active only in Normal mode; the Low-side drivers are disabled in Sleep and Stop mode.

**4.12.2 External Signal Description**

This section lists and describes the signals which do connect off-chip. Table 101 shows all the pins and their functions controlled by the Low-side module.

**Table 101. Pin Functions and Priorities**

Pin Name	Pin Function & Priority	I/O	Description	Pin Function after Reset
LS1	High Voltage Output	O	Low-side Power Output Driver, Active Clamping	LS1
LS2		O		LS2

## 4.12.3 Memory Map and Registers

### 4.12.3.1 Module Memory Map

Table 102 shows the register map of the Low-side Driver module. All Register addresses given are referenced to the D2D interface offset.

**Table 102. Low-Side Module - Memory Map**

Register Name		Bit 7	6	5	4	3	2	1	Bit 0
0x30 LSCR	R	LSOTIE	0	PWMCS2	PWMCS1	PWMLS2	PWMLS1	LS2	LS1
	W								
0x31 LSSR	R	LSOTC	0	0	0	LS2CL	LS1CL	LS2OL	LS1OL
	W								
0x32 LSCEN	R	0	0	0	0	LSCEN			
	W								

### 4.12.3.2 Register Descriptions

#### 4.12.3.2.1 Low-side Control Register (LSCR)

**Table 103. Low-side Control Register (LSCR)**

Offset<sup>(85)</sup> 0x30 Access: User read/write

	7	6	5	4	3	2	1	0
R	LSOTIE	0	PWMCS2	PWMCS1	PWMLS2	PWMLS1	LS2	LS1
W								
Reset	0	0	0	0	0	0	0	0

Note:

85. Offset related to 0x0200 for blocking access and 0x300 for non blocking access within the global address space.

**Table 104. LSCR - Register Field Descriptions**

Field	Description
7 - LSOTIE	Low-side Overtemperature Interrupt Enable
5 - PWMCS2	PWM Channel Select LS2 0 - PWM Channel 0 selected as PWM Channel 1 - PWM Channel 1 selected as PWM Channel
4 - PWMCS1	PWM Channel Select LS1 0 - PWM Channel 0 selected as PWM Channel 1 - PWM Channel 1 selected as PWM Channel
3 - PWMLS2	PWM Enable for LS2 0 - PWM disabled on LS2 1 - PWM enabled on LS2 (Channel as selected with PWMCS2)
2 - PWMLS1	PWM Enable for LS1 0 - PWM disabled on LS1 1 - PWM enabled on LS1 (Channel as selected with PWMCS1)
1 - LS2	LS2 Enable; LSEN has to be written once to control the LS2 Driver
0 - LS1	LS1 Enable; LSEN has to be written once to control the LS1 Driver

### 4.12.3.2.2 Low-side Status Register (LSSR)

**Table 105. Low-side Status Register (LSSR)**

Offset <sup>(86)</sup> 0x31		Access: User read							
		7	6	5	4	3	2	1	0
R		LSOTC	0	0	0	LS2CL	LS1CL	LS2OL	LS1OL
W									
Reset		0	0	0	0	0	0	0	0

Note:

86. Offset related to 0x0200 for blocking access and 0x300 for non blocking access within the global address space.

**Table 106. LSSR - Register Field Descriptions**

Field	Description
7 - LSOTC	Low-side Overtemperature condition present. Both drivers are turned off. Reading the register clears the LSOT interrupt flag if present. See <a href="#">Section 4.6, "Interrupts"</a> for details.
3 - LS2CL	Low-side 2 Current Limitation
2 - LS1CL	Low-side 1 Current Limitation
1 - LS2OL	Low-side 2 Open Load <sup>(87)</sup>
0 - LS1OL	Low-side 1 Open Load <sup>(87)</sup>

Note:

87. When the Low-side is in OFF state, the Open Load Detection function is not operating. When reading the LSSR register while the Low-side is operating in PWM and is in the OFF state, the LS1OL and LS2OL bits does not indicate Open Load.

### 4.12.3.2.3 Low-side Control Enable Register (LSCEN)

**Table 107. Low-side Enable Register (LSEN)**

Offset <sup>(88)</sup> 0x32		Access: User read/write							
		7	6	5	4	3	2	1	0
R		0	0	0	0	LSCEN			
W									
Reset		0	0	0	0	0	0	0	0

Note:

88. Offset related to 0x0200 for blocking access and 0x300 for non blocking access within the global address space.

**Table 108. LSEN - Register Field Descriptions**

Field	Description
3-0 LSCEN	Low-side Control Enable - To allow the LS Control via LSx, the correct value has to be written into the LSCEN Register. 0x5 - Low-side Control Enabled all other values - Low-side Control Disabled

## 4.12.4 Functional Description

The Low-side switches are controlled by the bits LS1:2 in the Low-side Control Register (LSCR). In order to control the Low-sides, the LSCEN register has to be correctly written once after RESET or VROV.

To protect the device against overvoltage when an inductive load (relay) is turned off an active clamp circuit is implemented.

#### 4.12.4.1 Voltage Regulator Overvoltage Protection

##### NOTE

The overvoltage threshold has to be trimmed at system power up. Refer to [Section 4.25.2.3, "Trimming Register 2 \(CTR2\)"](#) for details. The default trim is worst case and may have disabled the LS function already. An initial LS enable would be needed.

To protect the application for an unintentional activation of the drivers in case of a voltage regulator overvoltage failure, the Low-side Drivers automatically shuts down in case of an overvoltage on one of the two regulators.

The shutdown is fully handled in the analog section of the driver. This secures the feature in case the digital logic is damaged due to the overvoltage condition.

Once an overvoltage condition on one of the voltage regulators occurs, the LSx control bits in the Low-side Control Register (LSCR) is reset to 0. The Voltage Regulator Overvoltage Condition Bit (VROVC) in the Voltage Status Register (VSR) stays set as long as the condition is present. If the Voltage Regulator Overvoltage Interrupt was enabled (VROVIE=1), the VROV- Interrupt is issued. Reading the Voltage Regulator Overvoltage Condition Bit (VROVC) in the Voltage Status Register (VSR) clears the interrupt. To issue another VROV - Interrupt, the condition has to vanish and be present again.

To re-enable the Low-side Drivers after a Voltage Regulator Overvoltage condition occurred, first the LSCEN register has to be written with "0x05" - this information is processed through the main digital blocks, and would secure a minimum functionality before enabling the LS drivers again. In a second step, the LSx Control Bits in the Low-side Control Register (LSCR) must be enabled again after the overvoltage condition has vanished (VROVC=0).

#### 4.12.4.2 Open Load Detection

Each Low-side driver signals an open load condition if the current through the Low-side is below the open load current threshold. The open load condition is indicated with the bits LS1OL and LS2OL in the Low-side Status Register (LSSR).

When the Low-side is in OFF state, the Open Load Detection function is not operating. When reading the LSSR register while the Low-side is operating in PWM and is in the OFF state, the LS1OL and LS2OL bits does not indicate Open Load.

#### 4.12.4.3 Current Limitation

Each Low-side driver has a current limitation. In combination with the overtemperature shutdown, the Low-side drivers are protected against overcurrent and short-circuit failures.

The driver operates in current limitation, and is indicated with the bits LS1CL and LS2CL in the Low-side Status Register (LSSR).

Note: If the drivers is operating in current limitation mode excessive power might be dissipated.

#### 4.12.4.4 Overtemperature Protection (LS Interrupt)

Both Low-side drivers are protected against overtemperature. In case of an overtemperature condition, both Low-side drivers are shut down and the event is latched in the Interrupt Control Module. The shutdown is indicated as LS Interrupt in the Interrupt Source Register (ISR).

If the bit LSM is set in the Interrupt Mask Register (IMR) than an Interrupt (IRQ) is generated.

A write to the Low-side Control Register (LSCR) re-enables the Low-side drivers when the overtemperature condition is gone.

**4.12.5 PWM Capability**

See Section 4.13, "PWM Control Module (PWM8B2C)".

**4.12.6 Low-side Driver in Reverse Polarity**

Freescale recommends the user implement their systems using an external diode to protect the low-side driver (LSx) from potential damage (see Figure 22) in the event of a reverse polarity condition. However, if the user chooses to implement their system without an external diode, and a reverse polarity condition were to occur, the current would flow through the body diode of the LSx driver and through the closing coil of the relay, as shown in Figure 23. The magnitude of current through this body diode is determined by the characteristics of this relay coil. Since this body diode is not specified to carry a sustained minimum amount of current, Freescale strongly recommends users implement their systems using an external reverse polarity protection diode.

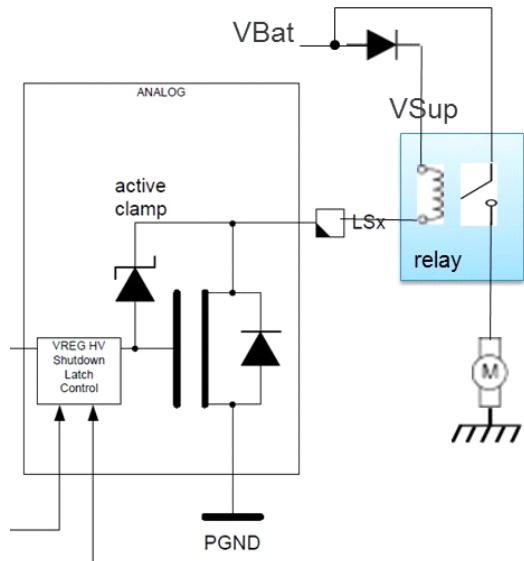

**Figure 22. Low-side Driver Implemented With External Reverse Polarity Diode**

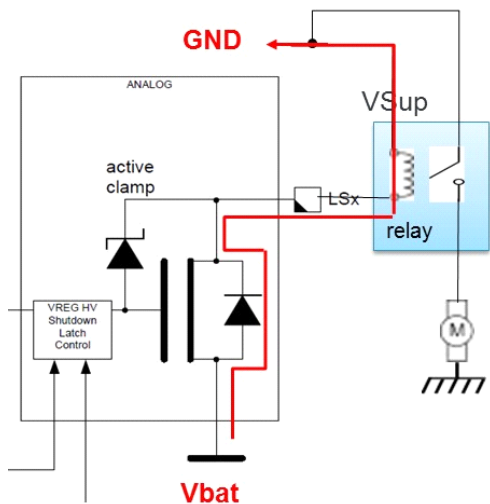

**Figure 23. Current Flow in Low-side Driver Under Reverse Polarity Condition Without External Diode**

## 4.13 PWM Control Module (PWM8B2C)

### 4.13.1 Introduction

To control the High-side (HS1, HS2) and the Low-side (LS1, LS2) duty cycle as well as the PTB2 output, the PWM module is implemented. Refer to the individual driver section for details on the use of the internal PWM1 and PWM0 signal ([Section 4.11, "High-side Drivers - HS"](#), [Section 4.12, "Low-side Drivers - LSx"](#) and [Section 4.17, "General Purpose I/O - PTB\[0...2\]"](#))

The PWM definition is based on the HC12 PWM definitions with some of the simplifications incorporated. The PWM module has two channels with independent controls of left and center aligned outputs on each channel.

Each of the two channels has a programmable period and duty cycle as well as a dedicated counter. A flexible clock select scheme allows a total of four different clock sources to be used with the counters. Each of the modulators can create independent continuous waveforms with software-selectable duty rates from 0% to 100%.

#### 4.13.1.1 Features

The PWM block includes these distinctive features:

- Two independent PWM channels with programmable periods and duty cycles
- Dedicated counter for each PWM channel
- Programmable PWM enable/disable for each channel
- Software selection of PWM duty pulse polarity for each channel
- Period and duty cycle are double buffered. Change takes effect when the end of the effective period is reached (PWM counter reaches zero), or when the channel is disabled
- Programmable center or left aligned outputs on individual channels
- Four clock sources (A, B, SA, and SB) provide for a wide range of frequencies
- Programmable clock select logic

#### 4.13.1.2 Modes of Operation

The PWM8B2C module does operate in Normal mode only.

#### 4.13.1.3 Block Diagram

Figure 24 shows the block diagram for the 8-bit 2-channel PWM block.

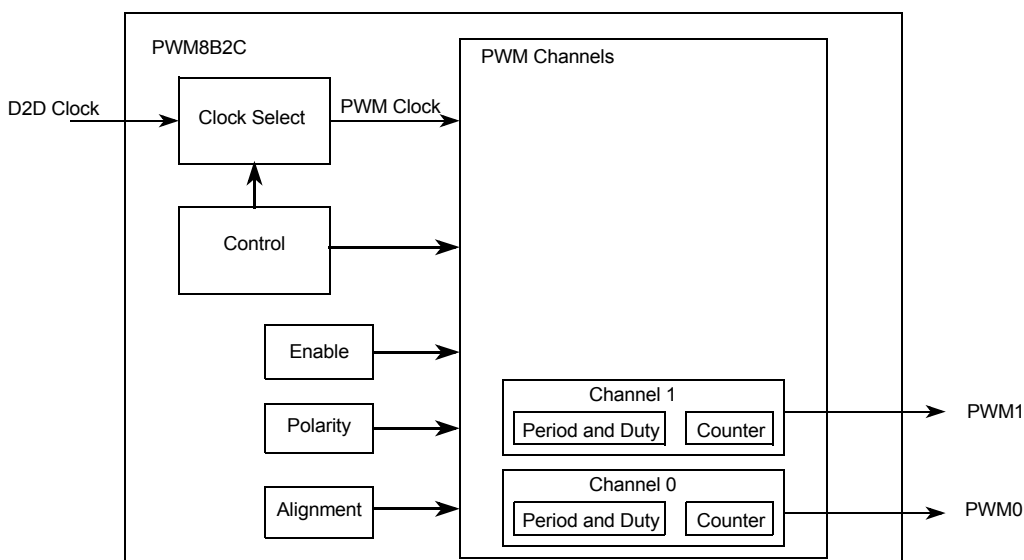

Figure 24. PWM Block Diagram

### 4.13.2 Signal Description

**NOTE**

Based on the D2D clock speed, the PWM8B2C module is capable of generating PWM signal frequencies higher than the maximum output frequency of the connected driver (HS, LS). Refer to [Section 3.6, “Dynamic Electrical Characteristics”](#) for details.

Do not exceed the driver maximum output frequency!

The PWM module has a total of two internal outputs to control the Low-side Outputs, the High-side Outputs and / or the PTB2 output with pulse width modulation. See [Section 4.11, “High-side Drivers - HS”](#), [Section 4.12, “Low-side Drivers - LSx”](#) and [Section 4.17, “General Purpose I/O - PTB\[0...2\]”](#) for configuration details.

#### 4.13.2.1 D2DCLK

Die 2 Die Interface Clock.

#### 4.13.2.2 PWM1 — Pulse Width Modulator Channel 1

This signal serves as waveform output of PWM channel 1.

#### 4.13.2.3 PWM0 — Pulse Width Modulator Channel 0

This signal serves as waveform output of PWM channel 0.

### 4.13.3 Register Descriptions

This section describes in detail all the registers and register bits in the PWM module. Reserved bits within a register always reads as 0 and the write is unimplemented. Unimplemented functions are indicated by shading the bit.

**Table 109. PWM Register Summary**

Name / Offset <sup>(89)</sup>		7	6	5	4	3	2	1	0
0x60 PWMCTL	R	CAE1	CAE0	PCLK1	PCLK0	PPOL1	PPOL0	PWME1	PWME0
	W								
0x61 PWMPRCLK	R	0	PCKB2	PCKB1	PCKB0	0	PCKA2	PCKA1	PCKA0
	W								
0x62 PWMSCLA	R	Bit 7	6	5	4	3	2	1	Bit 0
	W								
0x63 PWMSCLB	R	Bit 7	6	5	4	3	2	1	Bit 0
	W								
0x64 PWMCNT0	R	Bit 7	6	5	4	3	2	1	Bit 0
	W	0	0	0	0	0	0	0	0
0x65 PWMCNT1	R	Bit 7	6	5	4	3	2	1	Bit 0
	W	0	0	0	0	0	0	0	0
0x66 PWMPER0	R	Bit 7	6	5	4	3	2	1	Bit 0
	W								
0x67 PWMPER1	R	Bit 7	6	5	4	3	2	1	Bit 0
	W								
0x68 PWMDTY0	R	Bit 7	6	5	4	3	2	1	Bit 0
	W								

**Table 109. PWM Register Summary (continued)**

Name / Offset <sup>(89)</sup>		7	6	5	4	3	2	1	0
0x69 PWMDTY1	R	Bit 7	6	5	4	3	2	1	Bit 0
	W								

Note:

89. Offset related to 0x0200 for blocking access and 0x300 for non blocking access within the global address space.

#### 4.13.3.1 PWM Control Register (PWMCTL)

**Table 110. PWM Control Register (PWMCTL)**

 Offset<sup>(90)</sup> 0x60

Access: User read/write

	7	6	5	4	3	2	1	0
R	CAE1	CAE0	PCLK1	PCLK0	PPOL1	PPOL0	PWME1	PWME0
W								
Reset	0	0	0	0	0	0	0	0

Note:

90. Offset related to 0x0200 for blocking access and 0x300 for non blocking access within the global address space.

**Table 111. PWMCTL - Register Field Descriptions**

Field	Description
7–6 CAE[1:0]	Center Aligned Output Modes on Channels 1–0 0 Channels 1–0 operate in left aligned output mode. 1 Channels 1–0 operate in center aligned output mode.
5 PCLK1	Pulse Width Channel 1 Clock Select 0 Clock B is the clock source for PWM channel 1. 1 Clock SB is the clock source for PWM channel 1.
4 PCLK0	Pulse Width Channel 0 Clock Select 0 Clock A is the clock source for PWM channel 0. 1 Clock SA is the clock source for PWM channel 0.
3–2 PPOL[1:0]	Pulse Width Channel 1–0 Polarity Bits 0 PWM channel 1–0 outputs are low at the beginning of the period, then go high when the duty count is reached. 1 PWM channel 1–0 outputs are high at the beginning of the period, then go low when the duty count is reached.
1–0 PWME[1:0]	Pulse Width Channel 1–0 Enable 0 Pulse width channel 1–0 is disabled. 1 Pulse width channel 1–0 is enabled. The pulse modulated signal becomes available at PWM, output bit 1 when its clock source begins its next cycle.

##### 4.13.3.1.1 PWM Enable (PWME<sub>x</sub>)

**NOTE**

The first PWM cycle after enabling the channel can be irregular. If both PWM channels are disabled (PWME<sub>1–0</sub> = 0), the prescaler counter shuts off for power savings.

Each PWM channel has an enable bit (PWME<sub>x</sub>) to start its waveform output. When any of the PWME<sub>x</sub> bits are set (PWME<sub>x</sub> = 1), the associated PWM output is enabled immediately. However, the actual PWM waveform is not available on the associated PWM output until its clock source begins its next cycle, due to the synchronization of PWME<sub>x</sub> and the clock source.

##### 4.13.3.1.2 PWM Polarity (PPOL<sub>x</sub>)

**NOTE**

PPOL<sub>x</sub> register bits can be written anytime. If the polarity changes while a PWM signal is being generated, a truncated or stretched pulse can occur during the transition

The starting polarity of each PWM channel waveform is determined by the associated PPOLx bit. If the polarity bit is one, the PWM channel output is high at the beginning of the cycle and then goes low when the duty count is reached. Conversely, if the polarity bit is zero, the output starts low and then goes high when the duty count is reached.

**4.13.3.1.3 PWM Clock Select (PCLKx)**

**NOTE**

Register bits PCLK0 and PCLK1 can be written anytime. If a clock select changes while a PWM signal is being generated, a truncated or stretched pulse can occur during the transition.

Each PWM channel has a choice of two clocks to use as the clock source for their channel, as described by the following.

**4.13.3.1.4 PWM Center Align Enable (CAEx)**

**NOTE**

Write these bits only when the corresponding channel is disabled.

The CAEx bits select either center aligned outputs or left aligned output for both PWM channels. If the CAEx bit is set to a one, the corresponding PWM output is center aligned. If the CAEx bit is cleared, the corresponding PWM output is left aligned. See Section 4.13.4.2.5, "Left Aligned Outputs" and Section 4.13.4.2.6, "Center Aligned Outputs" for a more detailed description of the PWM output modes.

**4.13.3.2 PWM Prescale Clock Select Register (PWMPRCLK)**

**NOTE**

PCKB2–0 and PCKA2–0 register bits can be written anytime. If the clock pre-scale is changed while a PWM signal is being generated, a truncated or stretched pulse can occur during the transition.

This register selects the prescale clock source for clocks A and B independently.

**Table 112. PWM Prescale Clock Select Register (PWMPRCLK)**

Offset <sup>(91)</sup> 0x61								Access: User read/write	
		7	6	5	4	3	2	1	0
R		0	PCKB2	PCKB1	PCKB0	0	PCKA2	PCKA1	PCKA0
W									
Reset		0	0	0	0	0	0	0	0

Note:

91. Offset related to 0x0200 for blocking access and 0x300 for non blocking access within the global address space.

**Table 113. PWMPRCLK - Register Field Descriptions**

Field	Description
6–4 PCKB[2:0]	Prescaler Select for Clock B — Clock B is one of two clock sources which can be used for channel 1. These three bits determine the rate of clock B, as shown in Table 114.
2–0 PCKA[2:0]	Prescaler Select for Clock A — Clock A is one of two clock sources which can be used for channel 0. These three bits determine the rate of clock A, as shown in Table 115.

**Table 114. Clock B Prescaler Selects**

PCKB2	PCKB1	PCKB0	Value of Clock B
0	0	0	D2D clock
0	0	1	D2D clock / 2
0	1	0	D2D clock / 4
0	1	1	D2D clock / 8
1	0	0	D2D clock / 16

**Table 114. Clock B Prescaler Selects (continued)**

PCKB2	PCKB1	PCKB0	Value of Clock B
1	0	1	D2D clock / 32
1	1	0	D2D clock / 64
1	1	1	D2D clock / 128

**Table 115. Clock A Prescaler Selects**

PCKA2	PCKA1	PCKA0	Value of Clock A
0	0	0	D2D clock
0	0	1	D2D clock / 2
0	1	0	D2D clock / 4
0	1	1	D2D clock / 8
1	0	0	D2D clock / 16
1	0	1	D2D clock / 32
1	1	0	D2D clock / 64
1	1	1	D2D clock / 128

#### 4.13.3.3 PWM Scale A Register (PWMSCLA)

**NOTE**

When PWMSCLA = \$00, PWMSCLA value is considered a full scale value of 256. Clock A is thus divided by 512.

PWMSCLA is the programmable scale value used in scaling clock A to generate clock SA. Clock SA is generated by taking clock A, dividing it by the value in the PWMSCLA register and dividing it by two.

$$\text{Clock SA} = \text{Clock A} / (2 * \text{PWMSCLA})$$

Any value written to this register causes the scale counter to load the new scale value (PWMSCLA).

**Table 116. PWM Scale A Register (PWMSCLA)**

 Offset<sup>(92)</sup> 0x62

Access: User read/write

	7	6	5	4	3	2	1	0
R	Bit 7	6	5	4	3	2	1	Bit 0
W								
Reset	0	0	0	0	0	0	0	0

Note:

92. Offset related to 0x0200 for blocking access and 0x300 for non blocking access within the global address space.

#### 4.13.3.4 PWM Scale B Register (PWMSCLB)

**NOTE**

When PWMSCLB = \$00, PWMSCLB value is considered a full scale value of 256. Clock B is thus divided by 512.

PWMSCLB is the programmable scale value used in scaling clock B to generate clock SB. Clock SB is generated by taking clock B, dividing it by the value in the PWMSCLB register and dividing it by two.

$$\text{Clock SB} = \text{Clock B} / (2 * \text{PWMSCLB})$$

Any value written to this register causes the scale counter to load the new scale value (PWMSCLB).

**Table 117. PWM Scale B Register (PWMSCLB)**

Offset <sup>(93)</sup> 0x63								Access: User read/write	
		7	6	5	4	3	2	1	0
R		Bit 7	6	5	4	3	2	1	Bit 0
W									
Reset		0	0	0	0	0	0	0	0

Note:

93. Offset related to 0x0200 for blocking access and 0x300 for non blocking access within the global address space.

#### 4.13.3.5 PWM Channel Counter Registers (PWMCNTx)

**NOTE**

Writing to the counter while the channel is enabled can cause an irregular PWM cycle to occur.

Each channel has a dedicated 8-bit up/down counter, which runs at the rate of the selected clock source. The counter can be read at any time without affecting the count or the operation of the PWM channel. In left aligned output mode, the counter counts from 0 to the value in the period register - 1. In center aligned output mode, the counter counts from 0 up to the value in the period register and then back down to 0.

Any value written to the counter causes the counter to reset to \$00, the counter direction to be set to up, the immediate load of both duty and period registers with values from the buffers, and the output to change according to the polarity bit. The counter is also cleared at the end of the effective period (see [Section 4.13.4.2.5, "Left Aligned Outputs"](#) and [Section 4.13.4.2.6, "Center Aligned Outputs"](#) for more details). When the channel is disabled (PWME<sub>x</sub> = 0), the PWMCNT<sub>x</sub> register does not count. When a channel becomes enabled (PWME<sub>x</sub> = 1), the associated PWM counter starts at the count in the PWMCNT<sub>x</sub> register. For more detailed information on the operation of the counters, see [Section 4.13.4.2.4, "PWM Timer Counters"](#).

**Table 118. PWM Channel Counter Registers (PWMCNTx)**

Offset <sup>(94)</sup> 0x64/0x65								Access: User read/write	
		7	6	5	4	3	2	1	0
R		Bit 7	6	5	4	3	2	1	Bit 0
W		0	0	0	0	0	0	0	0
Reset		0	0	0	0	0	0	0	0

Note:

94. Offset related to 0x0200 for blocking access and 0x300 for non blocking access within the global address space.

#### 4.13.3.6 PWM Channel Period Registers (PWMPERx)

**NOTE**

Reads of this register return the most recent value written. Reads do not necessarily return the value of the currently active period due to the double buffering scheme.

There is a dedicated period register for each channel. The value in this register determines the period of the associated PWM channel. The period registers for each channel are double buffered, so if they change while the channel is enabled, the change does NOT take effect until one of the following occurs:

- The effective period ends
- The counter is written (counter resets to \$00)
- The channel is disabled

In this way, the output of the PWM is always either the old waveform or the new waveform, not some variation in between. If the channel is not enabled, then writes to the period register goes directly to the latches as well as the buffer. See [Section 4.13.4.2.3, "PWM Period and Duty"](#) for more information.

To calculate the output period, take the selected clock source period for the channel of interest (A, B, SA, or SB) and multiply it by the value in the period register for this channel:

- Left aligned output (CAEx = 0)
- PWMx Period = Channel Clock Period \* PWMPERx Center Aligned Output (CAEx = 1)
- PWMx Period = Channel Clock Period \* (2 \* PWMPERx)

For boundary case programming values, refer to [Section 4.13.4.2.7, "PWM Boundary Cases"](#).

**Table 119. PWM Channel Period Registers (PWMPERx)**

Offset <sup>(95)</sup>	0x66/0x67							Access: User read/write
	7	6	5	4	3	2	1	0
R	Bit 7	6	5	4	3	2	1	Bit 0
W								
Reset	0	0	0	0	0	0	0	0

Note:

95. Offset related to 0x0200 for blocking access and 0x300 for non blocking access within the global address space.

**4.13.3.7 PWM Channel Duty Registers (PWMDTYx)**

**NOTE**

Reads of this register return the most recent value written. Reads do not necessarily return the value of the currently active duty due to the double buffering scheme.

There is a dedicated duty register for each channel. The value in this register determines the duty of the associated PWM channel. The duty value is compared to the counter and if it is equal to the counter value a match occurs and the output changes state. The duty registers for each channel are double buffered, so if they change while the channel is enabled, the change does NOT take effect until one of the following occurs:

- The effective period ends
- The counter is written (counter resets to \$00)
- The channel is disabled

In this way, the output of the PWM is always either the old duty waveform or the new duty waveform, not some variation in between. If the channel is not enabled, then writes to the duty register goes directly to the latches as well as the buffer. See [Section 4.13.4.2.3, "PWM Period and Duty"](#) for more information.

**NOTE**

Depending on the polarity bit, the duty registers contains the count of either the high time or the low time. If the polarity bit is one, the output starts high and then goes low when the duty count is reached, so the duty registers contain a count of the high time. If the polarity bit is zero, the output starts low and then goes high when the duty count is reached, so the duty registers contain a count of the low time.

To calculate the output duty cycle (high time as a% of period) for a particular channel:

- Polarity = 0 (PPOLx = 0)
  - Duty Cycle = [(PWMPERx-PWMDTYx)/PWMPERx] \* 100%
- Polarity = 1 (PPOLx = 1)
  - Duty Cycle = [PWMDTYx / PWMPERx] \* 100%

For boundary case programming values, refer to [Section 4.13.4.2.7, "PWM Boundary Cases"](#).

**Figure 25. PWM Channel Duty Registers (PWMDTYx)**

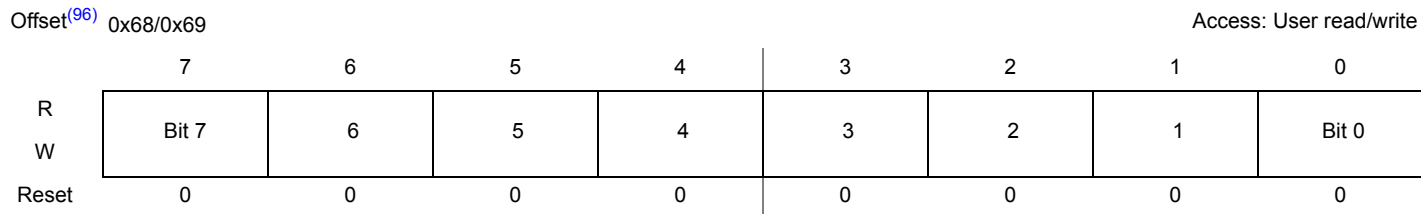

Note:  
 96. Offset related to 0x0200 for blocking access and 0x300 for non blocking access within the global address space.

**4.13.4 Functional Description**

**4.13.4.1 PWM Clock Select**

There are four available clocks: clock A, clock B, clock SA (scaled A), and clock SB (scaled B). These four clocks are based on the D2D clock.

Clock A and B can be software selected to be 1, 1/2, 1/4, 1/8, ..., 1/64, 1/128 times the D2D clock. Clock SA uses clock A as an input and divides it further with a reloadable counter. Similarly, clock SB uses clock B as an input and divides it further with a reloadable counter. The rates available for clock SA are software selectable to be clock A divided by 2, 4, 6, 8, ..., or 512 in increments of divide by 2. Similar rates are available for clock SB. Each PWM channel has the capability of selecting one of two clocks, either the pre-scaled clock (clock A or B) or the scaled clock (clock SA or SB). The block diagram in [Figure 26](#) shows the four different clocks and how the scaled clocks are created.

**4.13.4.1.1 Prescale**

The input clock to the PWM prescaler is the D2D clock. The input clock can also be disabled when both PWM channels are disabled (PWME1-0 = 0). This is useful for reducing power by disabling the prescale counter.

Clock A and clock B are scaled values of the input clock. The value is software selectable for both clock A and clock B and has options of 1, 1/2, 1/4, 1/8, 1/16, 1/32, 1/64, or 1/128 times the D2D clock. The value selected for clock A is determined by the PCKA2, PCKA1, PCKA0 bits in the PWMPRCLK register. The value selected for clock B is determined by the PCKB2, PCKB1, PCKB0 bits also in the PWMPRCLK register.

**4.13.4.1.2 Clock Scale**

The scaled A clock uses clock A as an input and divides it further with a user programmable value and then divides this by 2. The scaled B clock uses clock B as an input and divides it further with a user programmable value and then divides this by 2. The rates available for clock SA are software selectable to be clock A divided by 2, 4, 6, 8, ..., or 512 in increments of divide by 2. Similar rates are available for clock SB.

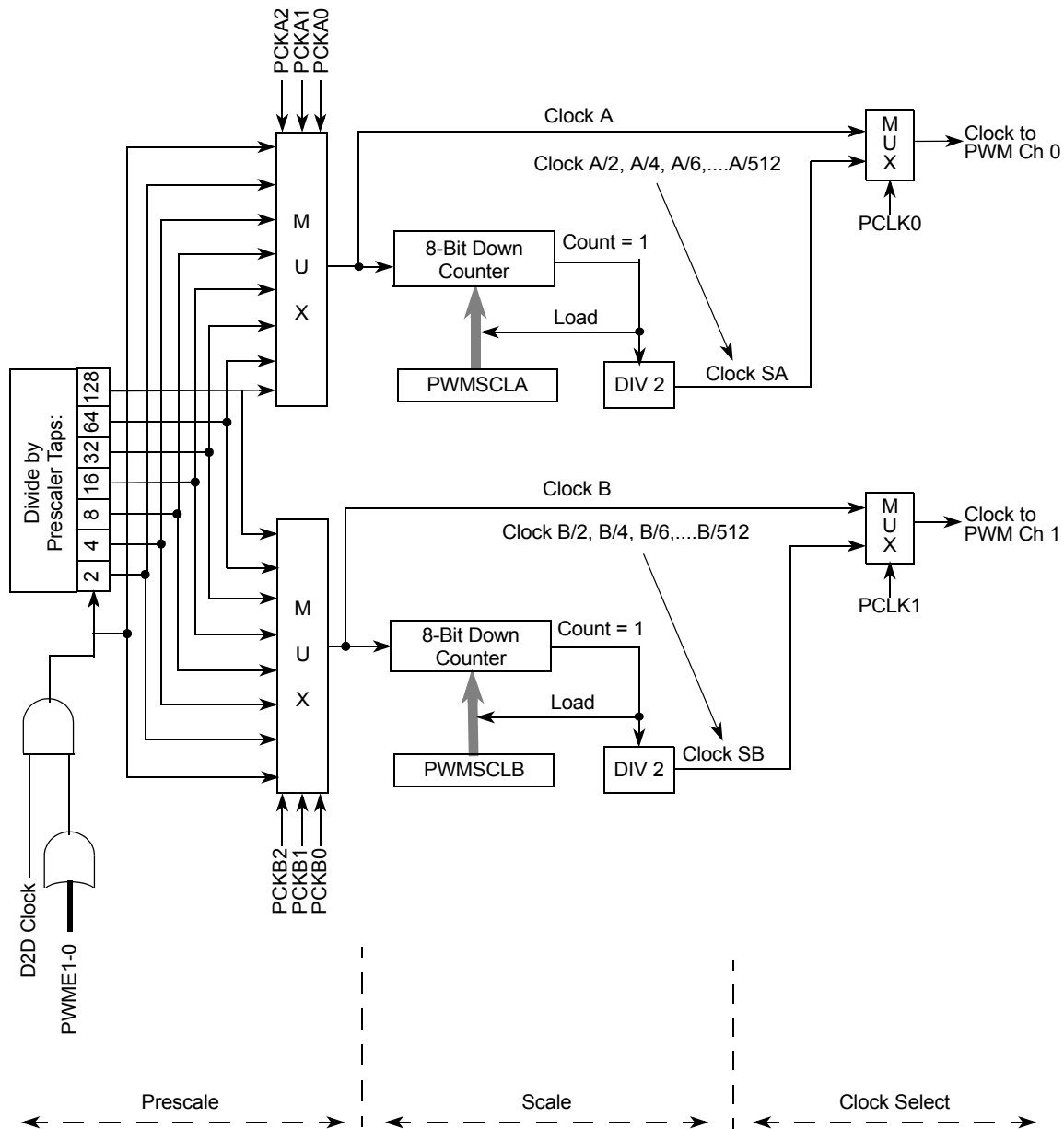
**Figure 26. PWM Clock Select Block Diagram**
**NOTE**

Clock SA = Clock A / (2 \* PWMSCLA)

When PWMSCLA = \$00, PWMSCLA value is considered a full scale value of 256. Clock A is thus divided by 512.

Clock A is used as an input to an 8-bit down counter. This down counter loads a user programmable scale value from the scale register (PWMSCLA). When the down counter reaches one, a pulse is output and the 8-bit counter is re-loaded. The output signal from this circuit is further divided by two. This gives a greater range with only a slight reduction in granularity. Clock SA equals clock A divided by two times the value in the PWMSCLA register.

**NOTE**

Clock SB = Clock B / (2 \* PWMSCLB)

When PWMSCLB = \$00, PWMSCLB value is considered a full scale value of 256. Clock B is thus divided by 512.

Similarly, clock B is used as an input to an 8-bit down counter followed by a divide by two producing clock SB. Thus, clock SB equals clock B divided by two times the value in the PWMSCLB register.

As an example, consider the case in which the user writes \$FF into the PWMSCLA register. Clock A for this case is E divided by 4. A pulse occurs at a rate of once every 255 x 4 E cycles. Passing this through the divide by two circuit produces a clock signal at an E divided by 2040 rate. Similarly, a value of \$01 in the PWMSCLA register when clock A is E divided by 4 produces a clock at an E divided by 8 rate.

**NOTE**

Writing to the scale registers while channels are operating can cause irregularities in the PWM outputs.

Writing to PWMSCLA or PWMSCLB causes the associated 8-bit down counter to be re-loaded. Otherwise, when changing rates the counter would have to count down to \$01 before counting at the proper rate. Forcing the associated counter to re-load the scale register value every time PWMSCLA or PWMSCLB is written prevents this.

**4.13.4.1.3 Clock Select**

**NOTE**

Changing clock control bits while channels are operating can cause irregularities in the PWM outputs.

Each PWM channel has the capability of selecting one of two clocks. For channels 0 the clock choice is clock A or clock SA. For channels 1 the choice is clock B or clock SB. The clock selection is done with the PCLKx control bits in the PWMCTL register.

**4.13.4.2 PWM Channel Timers**

The main part of the PWM module are the actual timers. Each of the timer channels has a counter, a period register, and a duty register (each are 8-bit). The waveform output period is controlled by a match between the period register and the value in the counter. The duty is controlled by a match between the duty register and the counter value, and causes the state of the output to change during the period. The starting polarity of the output is also selectable on a per channel basis. Shown in Figure 27 is the block diagram for the PWM timer.

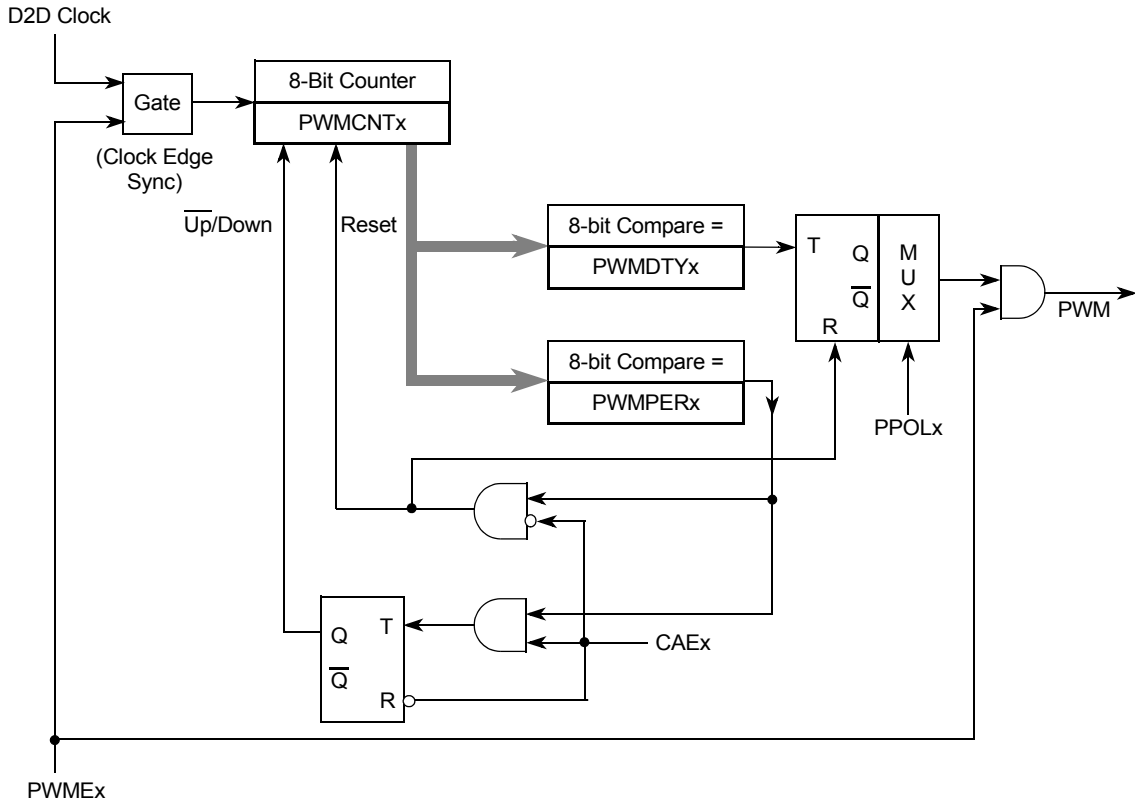

**Figure 27. PWM Timer Channel Block Diagram**

#### 4.13.4.2.1 PWM Enable

##### NOTE

The first PWM cycle after enabling the channel can be irregular.

Each PWM channel has an enable bit (PWME<sub>x</sub>) to start its waveform output. When any of the PWME<sub>x</sub> bits are set (PWME<sub>x</sub> = 1), the associated PWM output signal is enabled immediately. However, the actual PWM waveform is not available on the associated PWM output until its clock source begins its next cycle due to the synchronization of PWME<sub>x</sub> and the clock source.

On the front end of the PWM timer, the clock is enabled to the PWM circuit by the PWME<sub>x</sub> bit being high. There is an edge-synchronizing circuit to guarantee the clock is only enabled or disabled at an edge. When the channel is disabled (PWME<sub>x</sub> = 0), the counter for the channel does not count.

#### 4.13.4.2.2 PWM Polarity

Each channel has a polarity bit to allow starting a waveform cycle with a high or low signal. This is shown on the block diagram as a mux select of either the Q output or the  $\bar{Q}$  output of the PWM output flip flop. When one of the bits in the PWMPOL register is set, the associated PWM channel output is high at the beginning of the waveform, then goes low when the duty count is reached. Conversely, if the polarity bit is zero, the output starts low and then goes high when the duty count is reached.

#### 4.13.4.2.3 PWM Period and Duty

##### NOTE

When forcing a new period or duty into effect immediately, an irregular PWM cycle can occur. Depending on the polarity bit, the duty registers contains the count of either the high time or the low time.

Dedicated period and duty registers exist for each channel and are double buffered, so if they change while the channel is enabled, the change does NOT take effect until one of the following occurs:

- The effective period ends
- The counter is written (counter resets to \$00)
- The channel is disabled

In this way, the output of the PWM is always either the old waveform or the new waveform, not some variation in between. If the channel is not enabled, then writes to the period and duty registers goes directly to the latches as well as the buffer.

A change in duty or period can be forced into effect “immediately” by writing the new value to the duty and/or period registers, and then writing to the counter. This forces the counter to reset and the new duty and/or period values to be latched. In addition, since the counter is readable, it is possible to know where the count is with respect to the duty value, and software can be used to make adjustments

#### 4.13.4.2.4 PWM Timer Counters

##### NOTE

To start a new “clean” PWM waveform without any “history” from the old waveform, writing the channel counter (PWMCNT<sub>x</sub>) must happen prior to enabling the PWM channel (PWME<sub>x</sub> = 1).

Writing to the counter while the channel is enabled can cause an irregular PWM cycle to occur.

Each channel has a dedicated 8-bit up/down counter which runs at the rate of the selected clock source (see [Section 4.13.4.1, “PWM Clock Select”](#) for the available clock sources and rates). The counter compares to two registers, a duty register and a period register as shown in [Figure 27](#). When the PWM counter matches the duty register, the output flip-flop changes state, causing the PWM waveform to also change state. A match between the PWM counter and the period register behaves differently depending on what output mode is selected as shown in [Figure 27](#) and described in [Section 4.13.4.2.5, “Left Aligned Outputs”](#) and [Section 4.13.4.2.6, “Center Aligned Outputs”](#). Each channel counter can be read at anytime without affecting the count or the operation of the PWM channel.

Any value written to the counter causes the counter to reset to \$00, the counter direction to be set to up, the immediate load of both duty and period registers with values from the buffers, and the output to change according to the polarity bit. When the channel is disabled (PWME<sub>x</sub> = 0), the counter stops. When a channel becomes enabled (PWME<sub>x</sub> = 1), the associated PWM counter continues from the count in the PWMCNT<sub>x</sub> register. This allows the waveform to continue where it left off when the channel is re-enabled. When the channel is disabled, writing “0” to the period register causes the counter to reset on the next selected clock.

Generally, writes to the counter are done prior to enabling a channel in order to start from a known state. However, writing a counter can also be done while the PWM channel is enabled (counting). The effect is similar to writing the counter when the channel is disabled, except the new period is started immediately with the output set according to the polarity bit.

The counter is cleared at the end of the effective period (see [Section 4.13.4.2.5, "Left Aligned Outputs"](#) and [Section 4.13.4.2.6, "Center Aligned Outputs"](#) for more details).

**Table 120. PWM Timer Counter Conditions**

Counter Clears (\$00)	Counter Counts	Counter Stops
When PWMCNTx register written to any value	When PWM channel is enabled (PWME <sub>x</sub> = 1). Counts from last value in PWMCNTx.	When PWM channel is disabled (PWME <sub>x</sub> = 0)
Effective period ends		

**4.13.4.2.5 Left Aligned Outputs**

**NOTE**

Changing the PWM output mode from left aligned to center aligned output (or vice versa) while channels are operating can cause irregularities in the PWM output. It is recommended to program the output mode before enabling the PWM channel.

The PWM timer provides the choice of two types of outputs, left aligned or center aligned. They are selected with the CAEx bits in the PWMCTL register. If the CAEx bit is cleared (CAEx = 0), the corresponding PWM output is left aligned.

In left aligned output mode, the 8-bit counter is configured as an up counter only. It compares to two registers, a duty register and a period register as shown in the block diagram in [Figure 27](#). When the PWM counter matches the duty register the output flip-flop changes state causing the PWM waveform to also change state. A match between the PWM counter and the period register resets the counter and the output flip-flop, as shown in [Figure 27](#), as well as performing a load from the double buffer period and duty register to the associated registers, as described in [Section 4.13.4.2.3, "PWM Period and Duty"](#). The counter counts from 0 to the value in the period register – 1.

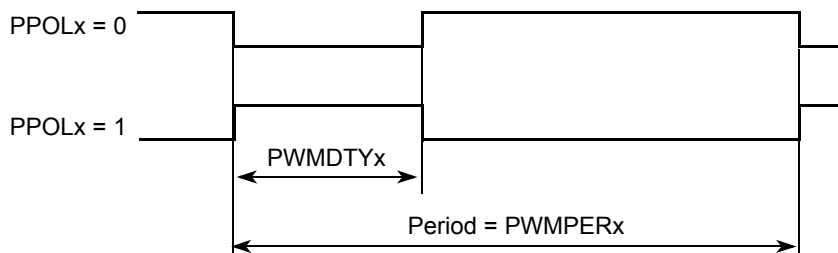

**Figure 28. PWM Left Aligned Output Waveform**

To calculate the output frequency in left aligned output mode for a particular channel, take the selected clock source frequency for the channel (A, B, SA, or SB), and divide it by the value in the period register for this channel.

- PWM<sub>x</sub> Frequency = Clock (A, B, SA, or SB) / PWMPER<sub>x</sub>
- PWM<sub>x</sub> Duty Cycle (high time as a% of period):
  - Polarity = 0 (PPOL<sub>x</sub> = 0)
- Duty Cycle = [(PWMPER<sub>x</sub>-PWMDTY<sub>x</sub>)/PWMPER<sub>x</sub>] \* 100%
  - Polarity = 1 (PPOL<sub>x</sub> = 1)
  - Duty Cycle = [PWMDTY<sub>x</sub> / PWMPER<sub>x</sub>] \* 100%

As an example of a left aligned output, consider the following case:

Clock Source = E, where E = 10 kHz (100  $\mu$ s period)  
 PPOLx = 0  
 PWMPERx = 4  
 PWMDTYx = 1  
 PWMx Frequency = 10 kHz/4 = 2.5 kHz  
 PWMx Period = 400  $\mu$ s  
 PWMx Duty Cycle = 3/4 \* 100% = 75%

The output waveform generated is shown in Figure 29.

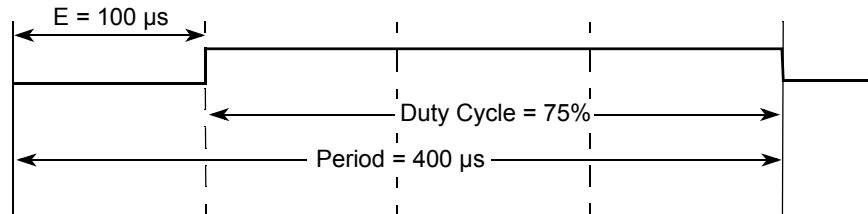

Figure 29. PWM Left Aligned Output Example Waveform

#### 4.13.4.2.6 Center Aligned Outputs

##### NOTE

Changing the PWM output mode from left aligned to center aligned output (or vice versa) while channels are operating can cause irregularities in the PWM output. It is recommended to program the output mode before enabling the PWM channel.

For a center aligned output mode selection, set the CAEx bit (CAEx = 1) in the PWMCTL register, and the corresponding PWM output is center aligned.

The 8-bit counter operates as an up/down counter in this mode, and is set to up whenever the counter is equal to \$00. The counter compares to two registers, a duty register and a period register, as shown in the block diagram in Figure 27. When the PWM counter matches the duty register, the output flip-flop changes state, causing the PWM waveform to also change state. A match between the PWM counter and the period register changes the counter direction from an up-count to a down-count. When the PWM counter decrements and matches the duty register again, the output flip-flop changes state, causing the PWM output to also change state. When the PWM counter decrements and reaches zero, the counter direction changes from a down-count back to an up-count, and a load from the double buffer period and duty registers to the associated registers is performed, as described in Section 4.13.4.2.3, "PWM Period and Duty". The counter counts from 0 up to the value in the period register and then back down to 0. Thus the effective period is  $PWMPERx \cdot 2$ .

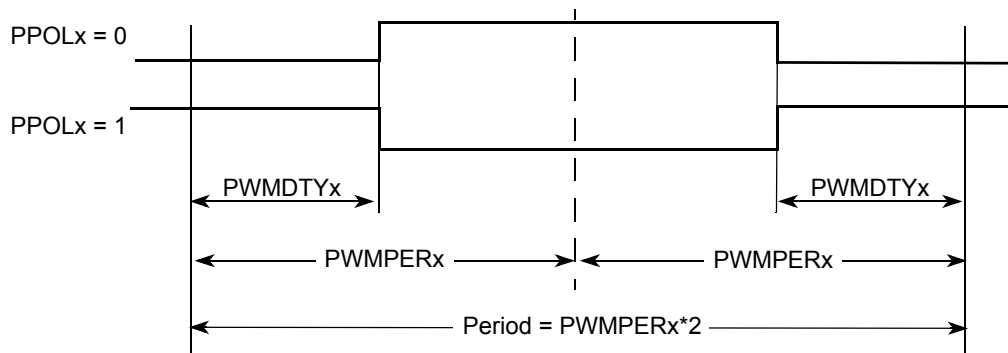

Figure 30. PWM Center Aligned Output Waveform

To calculate the output frequency in center aligned output mode for a particular channel, take the selected clock source frequency for the channel (A, B, SA, or SB) and divide it by twice the value in the period register for this channel.

- PWMx Frequency = Clock (A, B, SA, or SB) / (2\*PWMPERx)
- PWMx Duty Cycle (high time as a% of period):
  - Polarity = 0 (PPOLx = 0)  
Duty Cycle = [(PWMPERx-PWMDTYx)/PWMPERx] \* 100%
  - Polarity = 1 (PPOLx = 1)  
Duty Cycle = [PWMDTYx / PWMPERx] \* 100%

As an example of a center aligned output, consider the following case:

Clock Source = E, where E = 10 kHz (100 μs period)  
 PPOLx = 0  
 PWMPERx = 4  
 PWMDTYx = 1  
 PWMx Frequency = 10 kHz/8 = 1.25 kHz  
 PWMx Period = 800 μs  
 PWMx Duty Cycle = 3/4 \*100% = 75%

Figure 31 shows the output waveform generated.

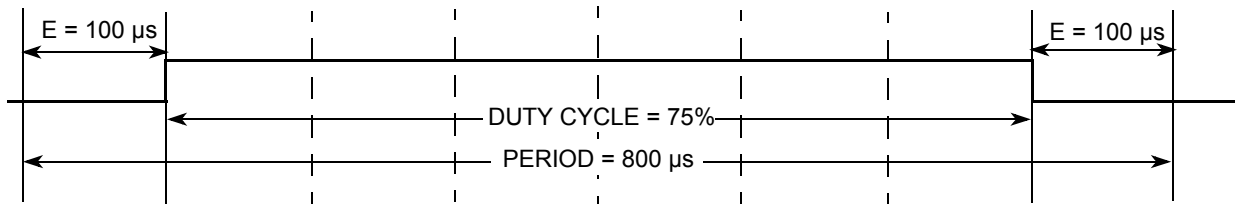

Figure 31. PWM Center Aligned Output Example Waveform

#### 4.13.4.2.7 PWM Boundary Cases

Table 121 summarizes the boundary conditions for the PWM, regardless of the output mode (left aligned or center aligned).

Table 121. PWM Boundary Cases

PWMDTYx	PWMPERx	PPOLx	PWMx Output
\$00 (indicates no duty)	>\$00	1	Always low
\$00 (indicates no duty)	>\$00	0	Always high
XX	\$00 <sup>(97)</sup> (indicates no period)	1	Always high
XX	\$00 <sup>(97)</sup> (indicates no period)	0	Always low
>= PWMPERx	XX	1	Always high

Note:

97. Counter = \$00 and does not count.

#### 4.13.5 Resets

The reset state of each individual bit is listed within the Section 4.13.3, "Register Descriptions", which details the registers and their bit-fields. All special functions or modes which are initialized during or just following reset are described within this section.

- The 8-bit up/down counter is configured as an up counter out of reset.
- All the channels are disabled and all the counters do not count.

### 4.13.6 Interrupts

The PWM module has no Interrupts.

## 4.14 LIN Physical Layer Interface - LIN

The LIN bus pin provides a physical layer for single-wire communication in automotive applications. The LIN physical layer is designed to meet the LIN physical layer version 2.1 specification, and has the following features:

- LIN physical layer 2.1 compliant
- Slew rate selection 20 kBit, 10 kBit, and fast Mode (100 kBit)
- Overtemperature Shutdown - HTI
- Permanent Pull-up in Normal mode 30 k $\Omega$ , 1.0 M $\Omega$  in low power
- Current limitation
- External Rx / Tx access. See [Section 4.17, "General Purpose I/O - PTB\[0...2\]"](#)
- Slew Rate Trim Bit. See [Section 4.25, "MM912F634 - Analog Die Trimming"](#)

The LIN driver is a Low-side MOSFET with current limitation and thermal shutdown. An internal pull-up resistor with a serial diode structure is integrated, so no external pull-up components are required for the application in a slave node. The fall time from dominant to recessive and the rise time from recessive to dominant is controlled. The symmetry between both slopes is guaranteed.

### 4.14.1 LIN Pin

The LIN pin offers high susceptibility immunity level from external disturbance, guaranteeing communication during external disturbance. See [Section 3.8, "ESD Protection and Latch-up Immunity"](#).

### 4.14.2 Slew Rate Selection

The slew rate can be selected for optimized operation at 10 kBit/s and 20 kBit/s as well as a fast baud rate (100 kBit) for test and programming. The slew rate can be adapted with the bits LINSR[1:0] in the LIN Register (LINR). The initial slew rate is 20 kBit/s.

### 4.14.3 Overtemperature Shutdown (LIN Interrupt)

The output Low-side FET (transmitter) is protected against overtemperature conditions. In case of an overtemperature condition, the transmitter is shutdown and the bit LINOTC in the LIN Register (LINR) is set as long as the condition is present.

If the LINOTIE bit is set in the LIN Register (LINR), an Interrupt IRQ is generated. Acknowledge the interrupt by reading the LIN Register (LINR). To issue a new interrupt, the condition has to vanish and occur again. The transmitter is automatically re-enabled once the overtemperature condition is gone and TxD is High.

### 4.14.4 Low Power Mode and Wake-up Feature

During Low Power mode operation the transmitter of the physical layer is disabled. The receiver is still active and able to detect Wake-up events on the LIN bus line. A dominant level longer than  $t_{PROPWL}$  followed by a rising edge, generates a wake-up event and be reported in the Wake-up Source Register (WSR).

### 4.14.5 J2602 Compliance

A Low Voltage Shutdown feature was implemented to allow controlled J2602 compliant LIN driver behavior under Low Voltage conditions (LVSD=0). When an undervoltage occurs on VS1 (LVI), the LIN stays in recessive mode if it was in recessive state. If it was in a dominant state, it waits until the next dominant to recessive transition, then it stays in the recessive state. When the undervoltage condition (LVI) is gone, the LIN starts operating when Tx is in a recessive state or on the next dominant to recessive transition.

**4.14.6 Register Definition**

**4.14.6.1 LIN Register (LINR)**

**Table 122. LIN Register (LINR)**

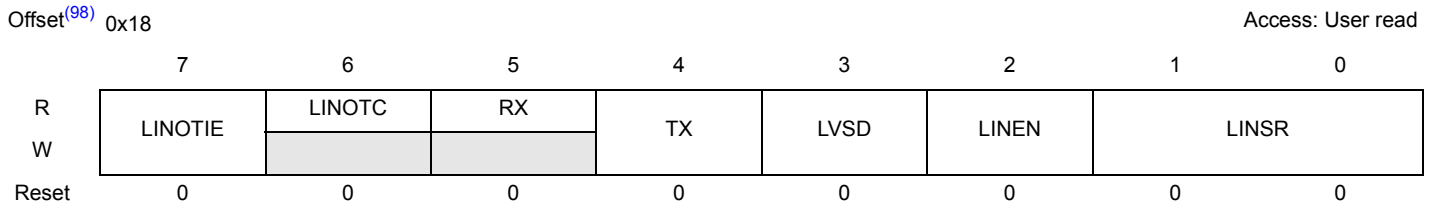

Note:

98. Offset related to 0x0200 for blocking access and 0x300 for non blocking access within the global address space.

**Table 123. LINR - Register Field Descriptions**

Field	Description
7 - LINOTIE	LIN - Overtemperature Interrupt Enable
6 - LINOTC	LIN - Overtemperature condition present. LIN driver is shut down. Reading this bit clears the LINOT interrupt flag.
5 - RX	LIN - Receiver (Rx) Status. 0 - LIN Bus Dominant 1 - LIN Bus Recessive
4 - TX	LIN - Direct Transmitter Control. The inverted signal is OR 0 - Transmitter not controlled 1 - Transmitter Dominant
3 - LVSD	LIN - Low Voltage Shutdown Disable (J2602 Compliance Control) 0 - LIN is set to recessive state in case of VS1 undervoltage condition 1 - LIN stays functional even with a VS1 undervoltage condition
2 - LINEN	LIN Module Enable 0 - LIN Module Disabled 1 - LIN Module Enabled
1-0 - LINSR	LIN - Slew Rate Select 00 - Normal Slew Rate (20 kBit) 01 - Slow Slew Rate (10.4 kBit) 10 - Fast Slew Rate (100 kBit) 11 - Normal Slew Rate (20 kBit)

**4.15 Serial Communication Interface (S08SCIV4)**

**4.15.1 Introduction**

**4.15.1.1 Features**

Features of the SCI module include:

- Full-duplex, standard non-return-to-zero (NRZ) format
- Double-buffered transmitter and receiver with separate enables
- Programmable baud rates (13-bit modulo divider)
- Interrupt-driven or polled operation:
  - Transmit data register empty and transmission complete
  - Receive data register full
  - Receive overrun, parity error, framing error, and noise error
  - Idle receiver detect
  - Active edge on receive pin
  - Break detect supporting LIN

- Hardware parity generation and checking
- Programmable 8-bit or 9-bit character length
- Receiver wake-up by idle-line or address-mark
- Optional 13-bit break character generation / 11-bit break character detection
- Selectable transmitter output polarity

### 4.15.1.2 Modes of Operation

See Section 4.15.3, “Functional Description,” For details concerning SCI operation in these modes:

- 8- and 9-bit data modes
- Loop mode
- Single-wire mode

### 4.15.1.3 Block Diagram

Figure 32 shows the transmitter portion of the SCI.

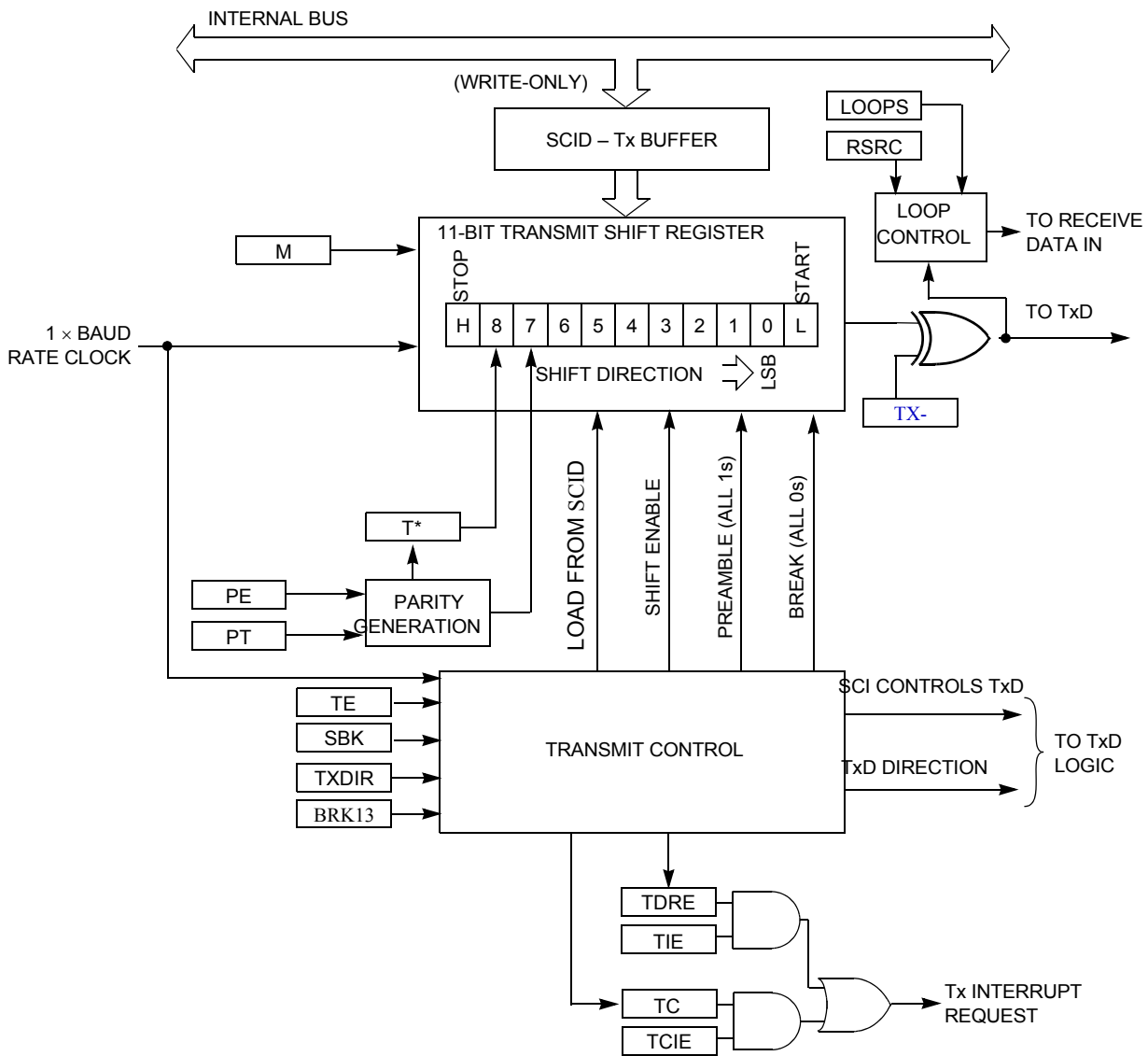

Figure 32. SCI Transmitter Block Diagram

Figure 33 shows the receiver portion of the SCI.

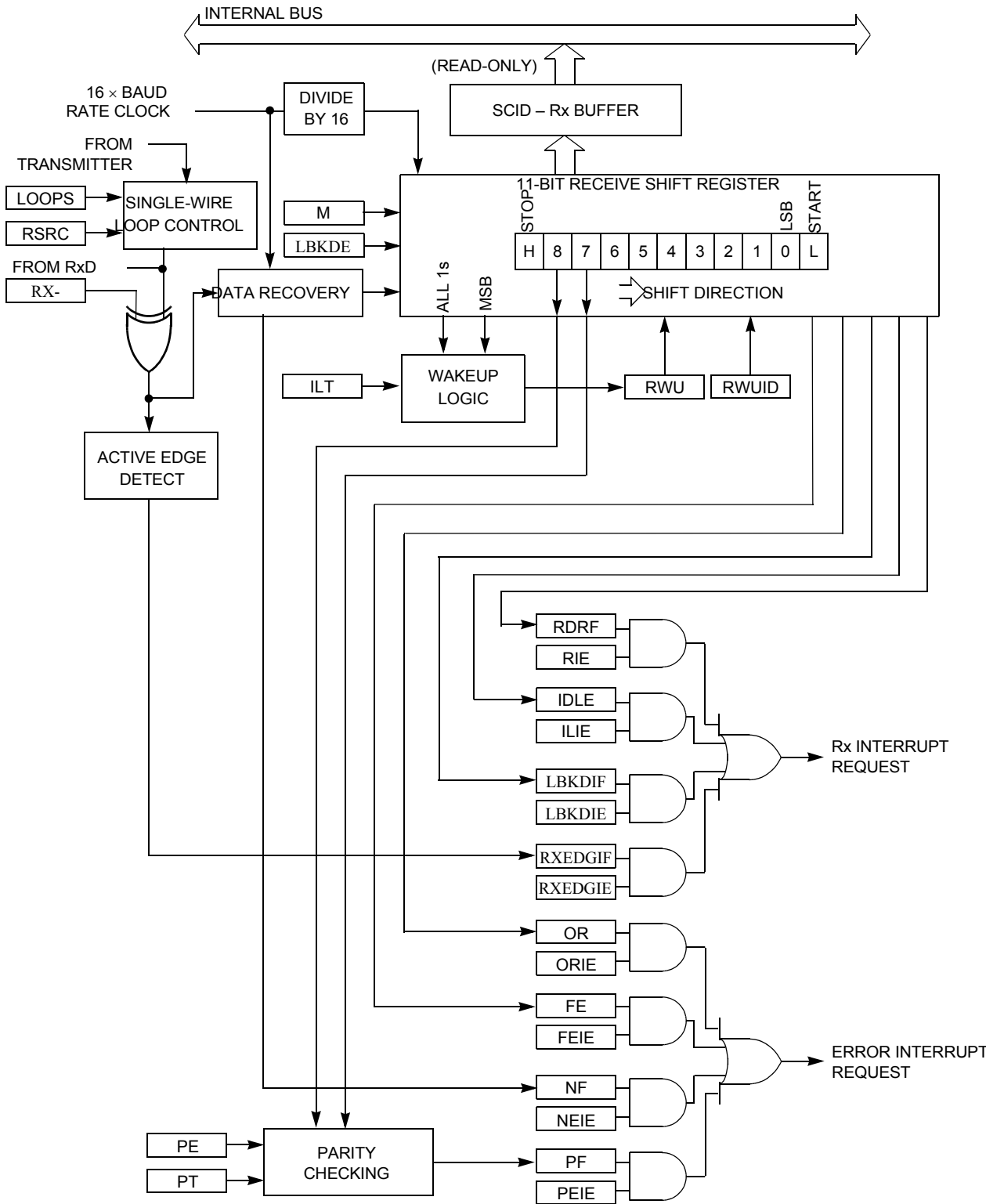

Figure 33. SCI Receiver Block Diagram

## 4.15.2 Register Definition

The SCI has eight 8-bit registers to control baud rate, select SCI options, report SCI status, and for transmit/receive data. Refer to [Section 4.5, “Die to Die Interface - Target”](#) of this data sheet for the absolute address assignments for all SCI registers. This section refers to registers and control bits only by their names.

### 4.15.2.1 SCI Baud Rate Registers (SCIBD (hi), SCIBD (lo))

This pair of registers controls the prescale divisor for SCI baud rate generation. To update the 13-bit baud rate setting [SBR12:SBR0], first write to SCIBD (hi) to buffer the high half of the new value, and then write to SCIBD (lo). The working value in SCIBD (hi) does not change until SCIBD (lo) is written.

SCIBDL is reset to a non-zero value, so after reset the baud rate generator remains disabled until the first time the receiver or transmitter is enabled (RE or TE bits in SCIC2 are written to 1).

**Table 124. SCI Baud Rate Register (SCIBD (hi))**

Offset <sup>(99)</sup>	0x40							Access: User read/write
	7	6	5	4	3	2	1	0
R	LBKDIE	RXEDGIE	0	SBR12	SBR11	SBR10	SBR9	SBR8
W								
Reset	0	0	0	0	0	0	0	0

Note:

99. Offset related to 0x0200 for blocking access and 0x300 for non blocking access within the global address space.

**Table 125. SCIBD (hi) Field Descriptions**

Field	Description
7 LBKDIE	<b>LIN Break Detect Interrupt Enable (for LBKDIF)</b> 0 Hardware interrupts from LBKDIF disabled (use polling). 1 Hardware interrupt requested when LBKDIF flag is 1.
6 RXEDGIE	<b>RxD Input Active Edge Interrupt Enable (for RXEDGIF)</b> 0 Hardware interrupts from RXEDGIF disabled (use polling). 1 Hardware interrupt requested when RXEDGIF flag is 1.
4:0 SBR[128]	<b>Baud Rate Modulo Divisor</b> — The 13 bits in SBR[12:0] are referred to collectively as BR, and they set the modulo divide rate for the SCI baud rate generator. When BR = 0, the SCI baud rate generator is disabled to reduce supply current. When BR = 1 to 8191, the SCI baud rate = BUSCLK/(16×BR). See also BR bits in <a href="#">Table 127</a> .

**Table 126. SCI Baud Rate Register (SCIBDL)**

Offset <sup>(100)</sup>	0x41							Access: User read/write
	7	6	5	4	3	2	1	0
R	SBR7	SBR6	SBR5	SBR4	SBR3	SBR2	SBR1	SBR0
W								
Reset	0	0	0	0	0	1	0	0

Note:

100. Offset related to 0x0200 for blocking access and 0x300 for non blocking access within the global address space.

**Table 127. SCIBDL Field Descriptions**

Field	Description
7:0 SBR[7:0]	<b>Baud Rate Modulo Divisor</b> — These 13 bits in SBR[12:0] are referred to collectively as BR, and they set the modulo divide rate for the SCI baud rate generator. When BR = 0, the SCI baud rate generator is disabled to reduce supply current. When BR = 1 to 8191, the SCI baud rate = BUSCLK/(16×BR). See also BR bits in <a href="#">Table 125</a> .

### 4.15.2.2 SCI Control Register 1 (SCIC1)

This read/write register is used to control various optional features of the SCI system.

**Table 128. SCI Control Register 1 (SCIC1)**

Offset <sup>(101)</sup> 0x42		Access: User read/write							
		7	6	5	4	3	2	1	0
R		0	0	0	0	0	0	0	0
W		0	0	0	0	0	0	0	0
Reset		0	0	0	0	0	0	0	0

Note:

101. Offset related to 0x0200 for blocking access and 0x300 for non blocking access within the global address space.

**Table 129. SCIC1 Field Descriptions**

Field	Description
7 LOOPS	<b>Loop Mode Select</b> — Selects between loop back modes and normal 2-pin full-duplex modes. When LOOPS = 1, the transmitter output is internally connected to the receiver input. 0 Normal operation — RxD and TxD use separate pins. 1 Loop mode or single-wire mode where transmitter outputs are internally connected to receiver input. (See RSRC bit.) RxD pin is not used by SCI.
5 RSRC	<b>Receiver Source Select</b> — This bit has no meaning or effect unless the LOOPS bit is set to 1. When LOOPS = 1, the receiver input is internally connected to the TxD pin and RSRC determines whether this connection is also connected to the transmitter output. 0 Provided LOOPS = 1, RSRC = 0 selects internal loop back mode and the SCI does not use the RxD pins. 1 Single-wire SCI mode where the TxD pin is connected to the transmitter output and receiver input.
4 M	<b>9-Bit or 8-Bit Mode Select</b> 0 Normal — start + 8 data bits (LSB first) + stop. 1 Receiver and transmitter use 9-bit data characters start + 8 data bits (LSB first) + 9th data bit + stop.
2 ILT	<b>Idle Line Type Select</b> — Setting this bit to 1 ensures the stop bit and logic 1 bits at the end of a character do not count toward the 10 or 11 bit times of logic high level needed by the idle line detection logic. Refer to <a href="#">Section 4.15.3.3.2.1, "Idle-line Wake-up"</a> for more information. 0 Idle character bit count starts after start bit. 1 Idle character bit count starts after stop bit.
1 PE	<b>Parity Enable</b> — Enables hardware parity generation and checking. When parity is enabled, the most significant bit (MSB) of the data character (eighth or ninth data bit) is treated as the parity bit. 0 No hardware parity generation or checking. 1 Parity enabled.
0 PT	<b>Parity Type</b> — Provided parity is enabled (PE = 1), this bit selects even or odd parity. Odd parity means the total number of 1s in the data character, including the parity bit, is odd. Even parity means the total number of 1s in the data character, including the parity bit, is even. 0 Even parity. 1 Odd parity.

### 4.15.2.3 SCI Control Register 2 (SCIC2)

This register can be read or written at any time.

**Table 130. SCI Control Register 2 (SCIC2)**

Offset <sup>(102)</sup>	0x43							Access: User read/write
	7	6	5	4	3	2	1	0
R	TIE	TCIE	RIE	ILIE	TE	RE	RWU	SBK
W								
Reset	0	0	0	0	0	0	0	0

Note:

102. Offset related to 0x0200 for blocking access and 0x300 for non blocking access within the global address space.

**Table 131. SCIC2 Field Descriptions**

Field	Description
7 TIE	<b>Transmit Interrupt Enable (for TDRE)</b> 0 Hardware interrupts from TDRE disabled (use polling). 1 Hardware interrupt requested when TDRE flag is 1.
6 TCIE	<b>Transmission Complete Interrupt Enable (for TC)</b> 0 Hardware interrupts from TC disabled (use polling). 1 Hardware interrupt requested when TC flag is 1.
5 RIE	<b>Receiver Interrupt Enable (for RDRF)</b> 0 Hardware interrupts from RDRF disabled (use polling). 1 Hardware interrupt requested when RDRF flag is 1.
4 LIE	<b>Idle Line Interrupt Enable (for IDLE)</b> 0 Hardware interrupts from IDLE disabled (use polling). 1 Hardware interrupt requested when IDLE flag is 1.
3 TE	<b>Transmitter Enable</b> 0 Transmitter off. 1 Transmitter on.  TE must be 1 in order to use the SCI transmitter. When TE = 1, the SCI forces the TxD pin to act as an output for the SCI system. When the SCI is configured for single-wire operation (LOOPS = RSRC = 1), TXDIR controls the direction of traffic on the single SCI communication line (TxD pin).  TE also can be used to queue an idle character by writing TE = 0 then TE = 1 while a transmission is in progress. Refer to <a href="#">Section 4.15.3.2.1, "Send Break and Queued Idle"</a> for more details.  When TE is written to 0, the transmitter keeps control of the port TxD pin until any data, queued idle, or queued break character finishes transmitting before allowing the pin to revert to a general-purpose I/O pin.
2 RE	<b>Receiver Enable</b> — When the SCI receiver is off, the RxD pin reverts to being a general-purpose port I/O pin. If LOOPS = 1 the RxD pin reverts to being a general-purpose I/O pin even if RE = 1. 0 Receiver off. 1 Receiver on.
1 RWU	<b>Receiver Wake-up Control</b> — This bit can be written to 1 to place the SCI receiver in a standby state where it waits for automatic hardware detection of a selected wake-up condition. The wake-up condition is either an idle line between messages (WAKE = 0, idle-line wake-up), or a logic 1 in the most significant data bit in a character (WAKE = 1, address-mark wake-up). Application software sets RWU and (normally) a selected hardware condition automatically clears RWU. Refer to <a href="#">Section 4.15.3.3.2, "Receiver Wake-up Operation"</a> for more details. 0 Normal SCI receiver operation. 1 SCI receiver in standby waiting for wake-up condition.
0 SBK	<b>Send Break</b> — Writing a 1 and then a 0 to SBK queues a break character in the transmit data stream. Additional break characters of 10 or 11 (13 or 14 if BRK13 = 1) bit times of logic 0 are queued as long as SBK = 1. Depending on the timing of the set and clear of SBK relative to the information currently being transmitted, a second break character may be queued before software clears SBK. Refer to <a href="#">Section 4.15.3.2.1, "Send Break and Queued Idle"</a> for more details. 0 Normal transmitter operation. 1 Queue break character(s) to be sent.

#### 4.15.2.4 SCI Status Register 1 (SCIS1)

This register has eight read-only status flags. Writes have no effect. Special software sequences (which do not involve writing to this register) are used to clear these status flags.

**Table 132. SCI Status Register 1 (SCIS1)**

Offset<sup>(103)</sup> 0x44

Access: User read/write

	7	6	5	4	3	2	1	0
R	TDRE	TC	RDRF	IDLE	OR	NF	FE	pF
W								
Reset	1	1	0	0	0	0	0	0

Note:

103. Offset related to 0x0200 for blocking access and 0x300 for non blocking access within the global address space.

**Table 133. SCIS1 Field Descriptions**

Field	Description
7 TDRE	<b>Transmit Data Register Empty Flag</b> — TDRE is set out of reset and when a transmit data value transfers from the transmit data buffer to the transmit shifter, leaving room for a new character in the buffer. To clear TDRE, read SCIS1 with TDRE = 1 and then write to the SCI data register (SCID). 0 Transmit data register (buffer) full. 1 Transmit data register (buffer) empty.
6 TC	<b>Transmission Complete Flag</b> — TC is set out of reset and when TDRE = 1 and no data, preamble, or break character is being transmitted. 0 Transmitter active (sending data, a preamble, or a break). 1 Transmitter idle (transmission activity complete). TC is cleared automatically by reading SCIS1 with TC = 1 and then doing one of the following three things: <ul style="list-style-type: none"> <li>Write to the SCI data register (SCID) to transmit new data</li> <li>Queue a preamble by changing TE from 0 to 1</li> <li>Queue a break character by writing 1 to SBK in SCIC2</li> </ul>
5 RDRF	<b>Receive Data Register Full Flag</b> — RDRF becomes set when a character transfers from the receive shifter into the receive data register (SCID). To clear RDRF, read SCIS1 with RDRF = 1 and then read the SCI data register (SCID). 0 Receive data register empty. 1 Receive data register full.
4 IDLE	<b>Idle Line Flag</b> — IDLE is set when the SCI receive line becomes idle for a full character time after a period of activity. When ILT = 0, the receiver starts counting idle bit times after the start bit. So if the receive character is all 1s, these bit times and the stop bit time count toward the full character time of logic high (10 or 11 bit times depending on the M control bit) needed for the receiver to detect an idle line. When ILT = 1, the receiver doesn't start counting idle bit times until after the stop bit. So the stop bit and any logic high bit times at the end of the previous character do not count toward the full character time of logic high needed for the receiver to detect an idle line. To clear IDLE, read SCIS1 with IDLE = 1 and then read the SCI data register (SCID). After IDLE has been cleared, it cannot become set again until after a new character has been received and RDRF has been set. IDLE gets set only once even if the receive line remains idle for an extended period. 0 No idle line detected. 1 Idle line was detected.
3 OR	<b>Receiver Overrun Flag</b> — OR is set when a new serial character is ready to be transferred to the receive data register (buffer), but the previously received character has not been read from SCID yet. In this case, the new character (and all associated error information) is lost because there is no room to move it into SCID. To clear OR, read SCIS1 with OR = 1 and then read the SCI data register (SCID). 0 No overrun. 1 Receive overrun (new SCI data lost).
2 NF	<b>Noise Flag</b> — The advanced sampling technique used in the receiver takes seven samples during the start bit and three samples in each data bit and the stop bit. If any of these samples disagrees with the rest of the samples within any bit time in the frame, the flag NF is set at the same time as the flag RDRF gets set for the character. To clear NF, read SCIS1 and then read the SCI data register (SCID). 0 No noise detected. 1 Noise detected in the received character in SCID.

**Table 133. SCIS1 Field Descriptions (continued)**

Field	Description
1 FE	<b>Framing Error Flag</b> — FE is set at the same time as RDRF when the receiver detects a logic 0 where the stop bit was expected. This suggests the receiver was not properly aligned to a character frame. To clear FE, read SCIS1 with FE = 1 and then read the SCI data register (SCID). 0 No framing error detected. This does not guarantee the framing is correct. 1 Framing error.
0 PF	<b>Parity Error Flag</b> — PF is set at the same time as RDRF when parity is enabled (PE = 1) and the parity bit in the received character does not agree with the expected parity value. To clear PF, read SCIS1 and then read the SCI data register (SCID). 0 No parity error. 1 Parity error.

#### 4.15.2.5 SCI Status Register 2 (SCIS2)

This register has one read-only status flag.

**Table 134. SCI Status Register 2 (SCIS2)**

 Offset<sup>(104)</sup> 0x45

Access: User read/write

	7	6	5	4	3	2	1	0
R	LBKDIF	RXEDGIF	0	RXINV <sup>(92)</sup>	RWUID	BRK13	LBKDE	RAF
W								
Reset	0	0	0	0	0	0	0	0

Note:

104. Offset related to 0x0200 for blocking access and 0x300 for non blocking access within the global address space.

**Table 135. SCIS2 Field Descriptions**

Field	Description
7 LBKDIF	<b>LIN Break Detect Interrupt Flag</b> — LBKDIF is set when the LIN break detect circuitry is enabled and a LIN break character is detected. LBKDIF is cleared by writing a “1” to it. 0 No LIN break character has been detected. 1 LIN break character has been detected.
6 RXEDGIF	<b>RxD Pin Active Edge Interrupt Flag</b> — RXEDGIF is set when an active edge (falling if RXINV = 0, rising if RXINV=1) on the RxD pin occurs. RXEDGIF is cleared by writing a “1” to it. 0 No active edge on the receive pin has occurred. 1 An active edge on the receive pin has occurred.
4 RXINV <sup>(105)</sup>	<b>Receive Data Inversion</b> — Setting this bit reverses the polarity of the received data input. 0 Receive data not inverted 1 Receive data inverted
3 RWUID	<b>Receive Wake Up Idle Detect</b> — RWUID controls whether the idle character wakes up the receiver sets the IDLE bit. 0 During receive standby state (RWU = 1), the IDLE bit does not get set upon detection of an idle character. 1 During receive standby state (RWU = 1), the IDLE bit gets set upon detection of an idle character.
2 BRK13	<b>Break Character Generation Length</b> — BRK13 is used to select a longer transmitted break character length. Detection of a framing error is not affected by the state of this bit. 0 Break character is transmitted with length of 10 bit times (11 if M = 1) 1 Break character is transmitted with length of 13 bit times (14 if M = 1)
1 LBKDE	<b>LIN Break Detection Enable</b> — LBKDE is used to select a longer break character detection length. While LBKDE is set, framing error (FE) and receive data register full (RDRF) flags are prevented from setting. 0 Break character detection disabled 1 Break character detection enabled

Note:

105. Setting RXINV inverts the RxD input for all cases: data bits, start and stop bits, break, and idle.

When using an internal oscillator in a LIN system, it is necessary to raise the break detection threshold by one bit time. Under the worst case timing conditions allowed in LIN, it is possible a 0x00 data character can appear to be 10.26 bit times long at a slave which is running 14% faster than the master. This would trigger normal break detection circuitry which is designed to detect a 10 bit break symbol. When the LBKDE bit is set, framing errors are inhibited and the break detection threshold changes from 10 bits to 11 bits, preventing false detection of a 0x00 data character as a LIN break symbol.

#### 4.15.2.6 SCI Control Register 3 (SCIC3)

**Table 136. SCI Control Register 3 (SCIC3)**

Offset <sup>(106)</sup>	0x46							Access: User read/write
	7	6	5	4	3	2	1	0
R	R8	T8	TXDIR	TXINV <sup>(94)</sup>	ORIE	NEIE	FEIE	PEIE
W								
Reset	0	0	0	0	0	0	0	0

Note:

106. Offset related to 0x0200 for blocking access and 0x300 for non blocking access within the global address space.

**Table 137. SCIC3 Field Descriptions**

Field	Description
7 R8	<b>Ninth Data Bit for Receiver</b> — When the SCI is configured for 9-bit data (M = 1), R8 can be thought of as a ninth receive data bit to the left of the MSB of the buffered data in the SCID register. When reading 9-bit data, read R8 before reading SCID because reading SCID completes automatic flag clearing sequences which could allow R8 and SCID to be overwritten with new data.
6 T8	<b>Ninth Data Bit for Transmitter</b> — When the SCI is configured for 9-bit data (M = 1), T8 may be thought of as a ninth transmit data bit to the left of the MSB of the data in the SCID register. When writing 9-bit data, the entire 9-bit value is transferred to the SCI shift register after SCID is written so T8 should be written (if it needs to change from its previous value) before SCID is written. If T8 does not need to change in the new value (such as when it is used to generate mark or space parity), it need not be written each time SCID is written.
5 TXDIR	<b>TxD Pin Direction in Single-wire Mode</b> — When the SCI is configured for single-wire half-duplex operation (LOOPS = RSRC = 1), this bit determines the direction of data at the TxD pin. 0 TxD pin is an input in single-wire mode. 1 TxD pin is an output in single-wire mode.
4 TXINV <sup>(107)</sup>	<b>Transmit Data Inversion</b> — Setting this bit reverses the polarity of the transmitted data output. 0 Transmit data not inverted 1 Transmit data inverted
3 ORIE	<b>Overrun Interrupt Enable</b> — This bit enables the overrun flag (OR) to generate hardware interrupt requests. 0 OR interrupts disabled (use polling). 1 Hardware interrupt requested when OR = 1.
2 NEIE	<b>Noise Error Interrupt Enable</b> — This bit enables the noise flag (NF) to generate hardware interrupt requests. 0 NF interrupts disabled (use polling). 1 Hardware interrupt requested when NF = 1.
1 FEIE	<b>Framing Error Interrupt Enable</b> — This bit enables the framing error flag (FE) to generate hardware interrupt requests. 0 FE interrupts disabled (use polling). 1 Hardware interrupt requested when FE = 1.
0 PEIE	<b>Parity Error Interrupt Enable</b> — This bit enables the parity error flag (PF) to generate hardware interrupt requests. 0 PF interrupts disabled (use polling). 1 Hardware interrupt requested when PF = 1.

Note:

107. Setting TXINV inverts the TxD output for all cases: data bits, start and stop bits, break, and idle.

### 4.15.2.7 SCI Data Register (SCID)

This register is actually two separate registers. Reads return the contents of the read-only receive data buffer and writes go to the write-only transmit data buffer. Reads and writes of this register are also involved in the automatic flag clearing mechanisms for the SCI status flags.

**Table 138. SCI Data Register (SCID)**

Offset <sup>(108)</sup>	0x47								Access: User read/write
	7	6	5	4	3	2	1	0	
R	R7	R6	R5	R4	R3	R2	R1	R0	
W	T7	T6	T5	T4	T3	T2	T1	T0	
Reset	0	0	0	0	0	0	0	0	

Note:

108. Offset related to 0x0200 for blocking access and 0x300 for non blocking access within the global address space.

### 4.15.3 Functional Description

The SCI allows full-duplex, asynchronous, NRZ serial communication among the MCU and remote devices, including other MCUs. The SCI comprises a baud rate generator, transmitter, and receiver block. The transmitter and receiver operate independently, although they use the same baud rate generator. During normal operation, the MCU monitors the status of the SCI, writes the data to be transmitted, and processes received data. The following describes each of the blocks of the SCI.

#### 4.15.3.1 Baud Rate Generation

As shown in Figure 34, the clock source for the SCI baud rate generator is the D2D clock.

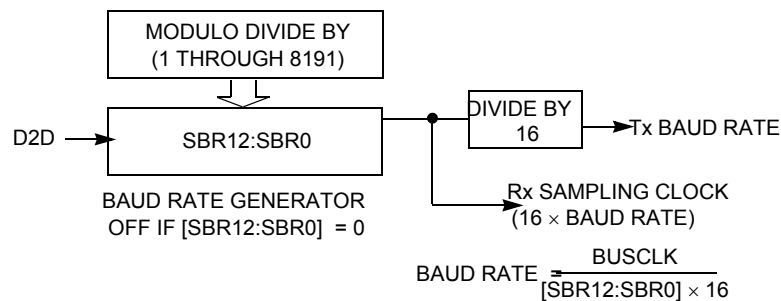

**Figure 34. SCI Baud Rate Generation**

SCI communications require the transmitter and receiver (which typically derive baud rates from independent clock sources) to use the same baud rate. Allowed tolerance on this baud frequency depends on the details of how the receiver synchronizes to the leading edge of the start bit and how bit sampling is performed.

The MCU resynchronizes to bit boundaries on every high-to-low transition, but in the worst case, there are no such transitions in the full 10- or 11-bit time character frame so any mismatch in baud rate is accumulated for the whole character time. For a Freescale Semiconductor SCI system whose bus frequency is driven by a crystal, the allowed baud rate mismatch is about  $\pm 4.5$  percent for 8-bit data format and about  $\pm 4.0$  percent for 9-bit data format. Although baud rate modulo divider settings do not always produce baud rates exactly matching standard rates, it is normally possible to get within a few percent, which is acceptable for reliable communications.

#### 4.15.3.2 Transmitter Functional Description

This section describes the overall block diagram for the SCI transmitter, as well as specialized functions for sending break and idle characters. The transmitter block diagram is shown in Figure 32.

The transmitter output (TxD) idle state defaults to logic high (TXINV = 0 following reset). The transmitter output is inverted by setting TXINV = 1. The transmitter is enabled by setting the TE bit in SCIC2. This queues a preamble character which is one full character frame of the idle state. The transmitter then remains idle until data is available in the transmit data buffer. Programs store data into the transmit data buffer by writing to the SCI data register (SCID).

The central element of the SCI transmitter is the transmit shift register which is either 10 or 11 bits long depending on the setting in the M control bit. For the remainder of this section, it is assumed M = 0, selecting the normal 8-bit data mode. In 8-bit data mode, the shift register holds a start bit, eight data bits, and a stop bit. When the transmit shift register is available for a new SCI character, the value waiting in the transmit data register is transferred to the shift register (synchronized with the baud rate clock) and the transmit data register empty (TDRE) status flag is set to indicate another character may be written to the transmit data buffer at SCID.

If no new character is waiting in the transmit data buffer after a stop bit is shifted out the TxD pin, the transmitter sets the transmit complete flag and enters an idle mode, with TxD high, waiting for more characters to transmit.

Writing 0 to TE does not immediately release the pin to be a general-purpose I/O pin. Any transmit activity in progress must first be completed. This includes data characters in progress, queued idle characters, and queued break characters.

#### 4.15.3.2.1 Send Break and Queued Idle

The SBK control bit in SCIC2 is used to send break characters which were originally used to gain the attention of old teletype receivers. Break characters are a full character time of logic 0 (10 bit times including the start and stop bits). A longer break of 13 bit times can be enabled by setting BRK13 = 1. Normally, a program would wait for TDRE to become set to indicate the last character of a message has moved to the transmit shifter, then write 1 and then write 0 to the SBK bit. This action queues a break character to be sent as soon as the shifter is available. If SBK is still 1 when the queued break moves into the shifter (synchronized to the baud rate clock), an additional break character is queued. If the receiving device is another Freescale Semiconductor SCI, the break characters is received as 0s in all eight data bits and a framing error (FE = 1) occurs.

When idle-line wake-up is used, a full character time of idle (logic 1) is needed between messages to wake up any sleeping receivers. Normally, a program would wait for TDRE to become set to indicate the last character of a message has moved to the transmit shifter, then write 0 and then write 1 to the TE bit. This action queues an idle character to be sent as soon as the shifter is available. As long as the character in the shifter does not finish while TE = 0, the SCI transmitter never actually releases control of the TxD pin. If there is a possibility of the shifter finishing while TE = 0, set the general-purpose I/O controls so the pin is shared with TxD is an output driving a logic 1. This ensures the TxD line looks like a normal idle line even if the SCI loses control of the port pin between writing 0 and then 1 to TE.

The length of the break character is affected by the BRK13 and M bits as shown below.

**Table 139. Break Character Length**

BRK13	M	Break Character Length
0	0	10 bit times
0	1	11 bit times
1	0	13 bit times
1	1	14 bit times

#### 4.15.3.3 Receiver Functional Description

In this section, the receiver block diagram (Figure 33) is used as a guide for the overall receiver functional description. Next, the data sampling technique used to reconstruct receiver data is described in more detail. Finally, two variations of the receiver wake-up function are explained.

The receiver input is inverted by setting RXINV = 1. The receiver is enabled by setting the RE bit in SCIC2. Character frames consist of a start bit of logic 0, eight (or nine) data bits (LSB first), and a stop bit of logic 1. For information about 9-bit data mode, refer to [Section 4.15.3.2, "8- and 9-bit data modes."](#) For the remainder of this discussion, it is assumed the SCI is configured for normal 8-bit data mode.

After receiving the stop bit into the receive shifter, and provided the receive data register is not already full, the data character is transferred to the receive data register and the receive data register full (RDRF) status flag is set. If RDRF was already set indicating the receive data register (buffer) was already full, the overrun (OR) status flag is set and the new data is lost. Because the SCI receiver is double-buffered, the program has one full character time after RDRF is set before the data in the receive data buffer must be read to avoid a receiver overrun.

When a program detects the receiving data register is full (RDRF = 1), it gets the data from the receive data register by reading SCID. The RDRF flag is cleared automatically by a 2-step sequence which is normally satisfied in the course of the user's program handling receive data. Refer to [Section 4.15.3.4, "Interrupts and Status Flags"](#) for more details about flag clearing.

#### 4.15.3.3.1 Data Sampling Technique

The SCI receiver uses a 16× baud rate clock for sampling. The receiver starts by taking logic level samples at 16 times the baud rate to search for a falling edge on the RxD serial data input pin. A falling edge is defined as a logic 0 sample after three consecutive logic 1 samples. The 16× baud rate clock is used to divide the bit time into 16 segments labeled RT1 through RT16. When a falling edge is located, three more samples are taken at RT3, RT5, and RT7 to make sure this was a real start bit and not merely noise. If at least two of these three samples are 0, the receiver assumes it is synchronized to a receive character.

The receiver then samples each bit time, including the start and stop bits, at RT8, RT9, and RT10 to determine the logic level for this bit. The logic level is interpreted to be of the majority of the samples taken during the bit time. In the case of the start bit, the bit is assumed to be 0 if at least two of the samples at RT3, RT5, and RT7 are 0 even if one or all of the samples taken at RT8, RT9, and RT10 are 1s. If any sample in any bit time (including the start and stop bits) in a character frame fails to agree with the logic level for this bit, the noise flag (NF) is set when the received character is transferred to the receive data buffer.

The falling edge detection logic continuously looks for falling edges, and if an edge is detected, the sample clock is resynchronized to bit times. This improves the reliability of the receiver in the presence of noise or mismatched baud rates. It does not improve worst case analysis because some characters do not have any extra falling edges anywhere in the character frame.

In the case of a framing error, provided the received character was not a break character, the sampling logic searching for a falling edge is filled with three logic 1 samples so a new start bit can be detected almost immediately.

In the case of a framing error, the receiver is inhibited from receiving any new characters until the framing error flag is cleared. The receive shift register continues to function, but a complete character cannot transfer to the receive data buffer if FE is still set.

#### 4.15.3.3.2 Receiver Wake-up Operation

Receiver wake-up is a hardware mechanism allowing an SCI receiver to ignore the characters in a message intended for a different SCI receiver. In such a system, all receivers evaluate the first character(s) of each message, and as soon as they determine the message is intended for a different receiver, they write logic 1 to the receiver wake up (RWU) control bit in SCIC2. When RWU bit is set, the status flags associated with the receiver (with the exception of the idle bit, IDLE, when RWUID bit is set) are inhibited from setting, thus eliminating the software overhead for handling the unimportant message characters. At the end of a message, or at the beginning of the next message, all receivers automatically force RWU to 0 so all receivers wake up in time to look at the first character(s) of the next message.

##### 4.15.3.3.2.1 Idle-line Wake-up

When WAKE = 0, the receiver is configured for idle-line wake-up. In this mode, RWU is cleared automatically when the receiver detects a full character time of the idle-line level. The M control bit selects 8-bit or 9-bit data mode which determines how many bit times of idle are needed to constitute a full character time (10 or 11 bit times because of the start and stop bits).

When RWU is one and RWUID is zero, the idle condition waking up the receiver does not set the IDLE flag. The receiver wakes up and waits for the first data character of the next message which sets the RDRF flag and generate an interrupt if enabled. When RWUID is one, any idle condition sets the IDLE flag and generates an interrupt if enabled, regardless of whether RWU is zero or one.

The idle-line type (ILT) control bit selects one of two ways to detect an idle line. When ILT = 0, the idle bit counter starts after the start bit so the stop bit and any logic 1s at the end of a character count toward the full character time of idle. When ILT = 1, the idle bit counter does not start until after a stop bit time, so the idle detection is not affected by the data in the last character of the previous message.

#### 4.15.3.3.2.2 Address-Mark Wake-up

When WAKE = 1, the receiver is configured for address-mark wake-up. In this mode, RWU is cleared automatically when the receiver detects a logic 1 in the most significant bit of a received character (eighth bit in M = 0 mode and ninth bit in M = 1 mode).

Address-mark wake-up allows messages to contain idle characters but requires the MSB be reserved for use in address frames. The logic 1 MSB of an address frame clears the RWU bit before the stop bit is received and sets the RDRF flag. In this case the character with the MSB set is received even though the receiver was sleeping during most of this character time.

#### 4.15.3.4 Interrupts and Status Flags

The SCI system has three separate interrupt vectors to reduce the amount of software needed to isolate the cause of the interrupt. One interrupt vector is associated with the transmitter for TDRE and TC events. Another interrupt vector is associated with the receiver for RDRF, IDLE, RXEDGIF and LBKDIF events, and a third vector is used for OR, NF, FE, and PF error conditions. Each of these ten interrupt sources can be separately masked by local interrupt enable masks. The flags can still be polled by software when the local masks are cleared to disable generation of hardware interrupt requests.

The SCI transmitter has two status flags which optionally can generate hardware interrupt requests. Transmit data register empty (TDRE) indicates when there is room in the transmit data buffer to write another transmit character to SCID. If the transmit interrupt enable (TIE) bit is set, a hardware interrupt is requested whenever TDRE = 1. Transmit complete (TC) indicates the transmitter is finished transmitting all data, preamble, and break characters and is idle with TxD at the inactive level. This flag is often used in systems with modems to determine when it is safe to turn off the modem. If the transmit complete interrupt enable (TCIE) bit is set, a hardware interrupt is requested whenever TC = 1. Instead of hardware interrupts, software polling may be used to monitor the TDRE and TC status flags if the corresponding TIE or TCIE local interrupt masks are 0s.

When a program detects the receive data register is full (RDRF = 1), it gets the data from the receive data register by reading SCID. The RDRF flag is cleared by reading SCIS1 while RDRF = 1 and then reading SCID.

When polling is used, this sequence is naturally satisfied in the normal course of the user program. If hardware interrupts are used, SCIS1 must be read in the interrupt service routine (ISR). Normally, this is done in the ISR anyway to check for receive errors, so the sequence is automatically satisfied.

The IDLE status flag includes logic preventing it from getting set repeatedly when the RxD line remains idle for an extended period of time. IDLE is cleared by reading SCIS1 while IDLE = 1 and then reading SCID. After IDLE has been cleared, it cannot become set again until the receiver has received at least one new character and has set RDRF.

If the associated error was detected in the received character causing RDRF to be set, the error flags — noise flag (NF), framing error (FE), and parity error flag (PF) — get set at the same time as RDRF. These flags are not set in overrun cases. If RDRF was already set when a new character is ready to be transferred from the receive shifter to the receive data buffer, the overrun (OR) flag gets set instead of the data along with any associated NF, FE, or PF condition is lost.

At any time, an active edge on the RxD serial data input pin causes the RXEDGIF flag to set. The RXEDGIF flag is cleared by writing a "1" to it. This function does depend on the receiver being enabled (RE = 1).

#### 4.15.3.5 Additional SCI Functions

The following sections describe additional SCI functions.

##### 4.15.3.5.1 8- and 9-Bit Data Modes

The SCI system (transmitter and receiver) can be configured to operate in 9-bit data mode by setting the M control bit in SCIC1. In 9-bit mode, there is a ninth data bit to the left of the MSB of the SCI data register. For the transmit data buffer, this bit is stored in T8 in SCIC3. For the receiver, the ninth bit is held in R8 in SCIC3.

For coherent writes to the transmit data buffer, write to the T8 bit before writing to SCID.

If the bit value to be transmitted as the ninth bit of a new character is the same as for the previous character, it is not necessary to write to T8 again. When data is transferred from the transmit data buffer to the transmit shifter, the value in T8 is copied at the same time data is transferred from SCID to the shifter.

9-bit data mode typically is used in conjunction with parity to allow eight bits of data plus the parity in the ninth bit. Or it is used with address-mark wake-up so the ninth data bit can serve as the wake-up bit. In custom protocols, the ninth bit can also serve as a software-controlled marker.

#### 4.15.3.5.2 Stop Mode Operation

During all stop modes, clocks to the SCI module are halted. In stop1 and stop2 modes, all SCI register data is lost and must be re-initialized upon recovery from these two stop modes. No SCI module registers are affected in stop3 mode.

The receive input active edge detect circuit is still active in stop3 mode, but not in stop2. An active edge on the receive input brings the CPU out of stop3 mode if the interrupt is not masked (RXEDGIE = 1).

Note that because the clocks are halted, the SCI module resumes operation upon exit from stop (only in stop3 mode). Software should ensure stop mode is not entered while there is a character being transmitted out of or received into the SCI module.

#### 4.15.3.5.3 Loop Mode

When LOOPS = 1, the RSRC bit in the same register chooses between loop mode (RSRC = 0) or single-wire mode (RSRC = 1). Loop mode is sometimes used to check software, independent of connections in the external system, to help isolate system problems. In this mode, the transmitter output is internally connected to the receiver input and the RxD pin is not used by the SCI, so it reverts to a general purpose port I/O pin.

#### 4.15.3.5.4 Single-wire Operation

When LOOPS = 1, the RSRC bit in the same register chooses between loop mode (RSRC = 0) or single-wire mode (RSRC = 1). Single-wire mode is used to implement a half-duplex serial connection. The receiver is internally connected to the transmitter output and to the TxD pin. The RxD pin is not used and reverts to a general purpose port I/O pin.

In single-wire mode, the TXDIR bit in SCIC3 controls the direction of serial data on the TxD pin. When TXDIR = 0, the TxD pin is an input to the SCI receiver and the transmitter is temporarily disconnected from the TxD pin so an external device can send serial data to the receiver. When TXDIR = 1, the TxD pin is an output driven by the transmitter. In single-wire mode, the internal loop back connection from the transmitter to the receiver causes the receiver to receive characters sent out by the transmitter.

## 4.16 High Voltage Inputs - Lx

Six High Voltage capable inputs are implemented with the following features:

- Digital Input Capable
- Analog Input Capable with selectable voltage divider.
- Wake-up Capable during Low Power mode. See [Section 4.8, "Wake-up / Cyclic Sense"](#).

When used as analog inputs to sense voltages outside the module a series resistor must be used on the used input. When a Lx input is not selected in the analog multiplexer, the voltage divider is disconnected from this input. When a Lx input is selected in the analog multiplexer, it is disconnected in low power mode if configured as Wake-up input. Unused Lx pins are recommended to be connected to GND to improve EMC behavior.

### 4.16.1 Register Definition

#### 4.16.1.1 Lx Status Register (LXR)

**Table 140. Lx Status Register (LXR)**

Offset <sup>(109)</sup>	0x08							Access: User read
	7	6	5	4	3	2	1	0
R	0	0	L5	L4	L3	L2	L1	L0
W								

Note:

109. Offset related to 0x0200 for blocking access and 0x300 for non blocking access within the global address space.

**Table 141. LXR - Register Field Descriptions**

Field	Description
L[5-0]	Lx Status Register - Current Digital State of the Lx Input

#### 4.16.1.2 Lx Control Register (LXCR)

**Table 142. Lx Control Register (LXCR)**

Offset<sup>(110)</sup> 0x09

Access: User read/write

	7	6	5	4	3	2	1	0
R	0	0	L5DS	L4DS	L3DS	L2DS	L1DS	L0DS
W								
Reset	0	0	0	0	0	0	0	0

Note:

110. Offset related to 0x0200 for blocking access and 0x300 for non blocking access within the global address space.

**Table 143. LXCR - Register Field Descriptions**

Field	Description
5-0 L[5-0]DS	Analog Input Divider Ratio Selection - Lx 0 - 2 (typ.) 1 - 7.2 (typ)

### 4.17 General Purpose I/O - PTB[0...2]

The three multipurpose I/O pins can be configured to operate as documented in the table below.

**Table 144. General purpose I/O - Operating modes**

Priority	Function	PTB2	PTB1	PTB0	Chp/Pg
1 (H)	2.5 V Analog Input	AD2	AD1	AD0	4.18/124
2	Timer Input Capture / Output Compare	TIMCH2	TIMCH1	TIMCH0	4.17/111
3	LIN / SCI - Rx / Tx (PTB0...1) or PWM (PTB2)	PWM	Tx	Rx	4.13/91
4 (L)	5.0 V Input Output	PTB2	PTB1	PTB0	current

The alternate function of PTB2, PTB1 and PTB0 can be configured by selecting the function in the corresponding module (e.g. TIMER). The selection with the highest priority takes effect when more than one function is selected.

#### 4.17.1 Digital I/O Functionality

All three pins act as standard digital Inputs / Outputs with selectable pull-up resistor.

#### 4.17.2 Alternative SCI / LIN Functionality

For alternative serial configuration and for debug and certification purpose, PTB0 and PTB1 can be configured to connect to the internal LIN and / or SCI signals (RxD and TxD). [Figure 35](#) shows the 4 available configurations.

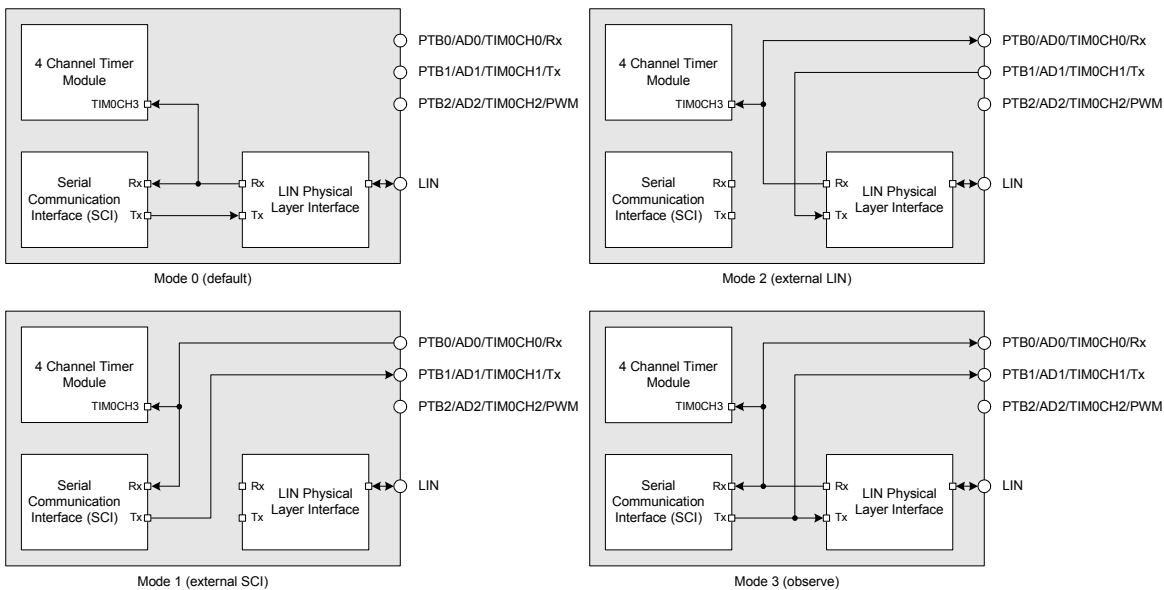

Figure 35. Alternative SCI / LIN Functionality

4.17.3 Alternative PWM Functionality

As an alternative routing for the PWM channel (0 or 1) output, the PortB 2 (PTB2) can be configured to output one of the two PWM channels defined in the Section 4.13, "PWM Control Module (PWM8B2C)". The selection and output enable can be configured in the Port B Configuration Register 2 (PTBC2).

4.17.4 Register definition

4.17.4.1 Port B Configuration Register 1 (PTBC1)

Table 145. Port B Configuration Register 1 (PTBC1)

Offset <sup>(111)</sup>	0x20							Access: User read/write
	7	6	5	4	3	2	1	0
R	0	PUEB2	PUEB1	PUEB0	0	DDRB2	DDRB1	DDRB0
W								
Reset	0	0	0	0	0	0	0	0

Note:

111. Offset related to 0x0200 for blocking access and 0x300 for non blocking access within the global address space.

Table 146. PTBC1 - Register Field Descriptions

Field	Description
6-4 PUEB[2-0]	Pull-up Enable Port B[2...0] 0 - Pull-up disabled on PTBx pin. 1 - Pull-up enabled on PTBx pin.
2-0 DDRB[2-0]	Data Direction Port B[2...0] 0 - PTBx configured as input. 1 - PTBx configured as output.

**NOTE**

The pull-up resistor is not active once the port is configured as an output.

**4.17.4.2 Port B Configuration Register 2 (PTBC2)**

**Table 147. Port B Configuration Register 2 (PTBC2)**

Offset<sup>(112)</sup> 0x21 Access: User read/write

	7	6	5	4	3	2	1	0
R	0	0	0	0	PWMCS	PWMEN	SERMOD	
W								
Reset	0	0	0	0	0	0	0	0

Note:  
112. Offset related to 0x0200 for blocking access and 0x300 for non blocking access within the global address space.

**Table 148. PTBC2 - Register Field Descriptions**

Field	Description
3 PWMCS	PWM Channel Select PTB2. See <a href="#">Section 4.13, "PWM Control Module (PWM8B2C)"</a> . 0 - PWM Channel 0 selected as PWM Channel for PTB2 1 - PWM Channel 1 selected as PWM Channel for PTB2
2 PWMEN	PWM Enable for PTB2. See <a href="#">Section 4.13, "PWM Control Module (PWM8B2C)"</a> . 0 - PWM disabled on PTB2 1 - PWM enabled on PTB2 (Channel as selected with PWMCS)
1-0 SERMOD	Serial Mode Select for PTB0 and PTB1. See <a href="#">Figure 35</a> for details. 00 - Mode 0, SCI internally connected the LIN Physical Layer Interface. PTB0 and PTB1 are Digital I/Os 01 - Mode 1, SCI connected to PTB0 and PTB1 (external SCI mode) 10 - Mode 2, LIN Physical Layer Interface connected to PTB0 and PTB1 (external LIN mode) 11 - Mode 3, SCI internally connected the LIN Physical Layer Interface and PTB0 and PTB1 are connected both as outputs (Observe mode)

**4.17.4.3 Port B Data Register (PTB)**

**Table 149. Port B Data Register (PTB)**

Offset<sup>(113)</sup> 0x22 Access: User read/write

	7	6	5	4	3	2	1	0
R	0	0	0	0	0	PTB2	PTB1	PTB0
W								
Reset	0	0	0	0	0	0	0	0

Note:  
113. Offset related to 0x0200 for blocking access and 0x300 for non blocking access within the global address space.

**Table 150. PTB - Register Field Descriptions**

Field	Description
2-0 PTB[2-0]	Port B general purpose input/output data — Data Register If the associated data direction bit of this pin is set to 1, a read returns the value of the port register, otherwise the buffered and synchronized pin input state is read.

## 4.18 Basic Timer Module - TIM (TIM16B4C)

### 4.18.1 Introduction

#### 4.18.1.1 Overview

The basic timer consists of a 16-bit, software-programmable counter driven by a seven-stage programmable prescaler. This timer can be used for many purposes, including input waveform measurements while simultaneously generating an output waveform. Pulse widths can vary from microseconds to many seconds.

This timer contains 4 complete input capture/output compare channels [IOC 3:2]. The input capture function is used to detect a selected transition edge and record the time. The output compare function is used for generating output signals or for timer software delays.

A full access for the counter registers or the input capture/output compare registers should take place in 16bit word access. Accessing high byte and low byte separately for all of these registers may not yield the same result as accessing them in one word.

#### 4.18.1.2 Features

The TIM16B4C includes these distinctive features:

- Four input capture/output compare channels.
- Clock prescaler
- 16-bit counter

#### 4.18.1.3 Modes of Operation

The TIM16B4C is only active during Normal mode.

#### 4.18.1.4 Block Diagram

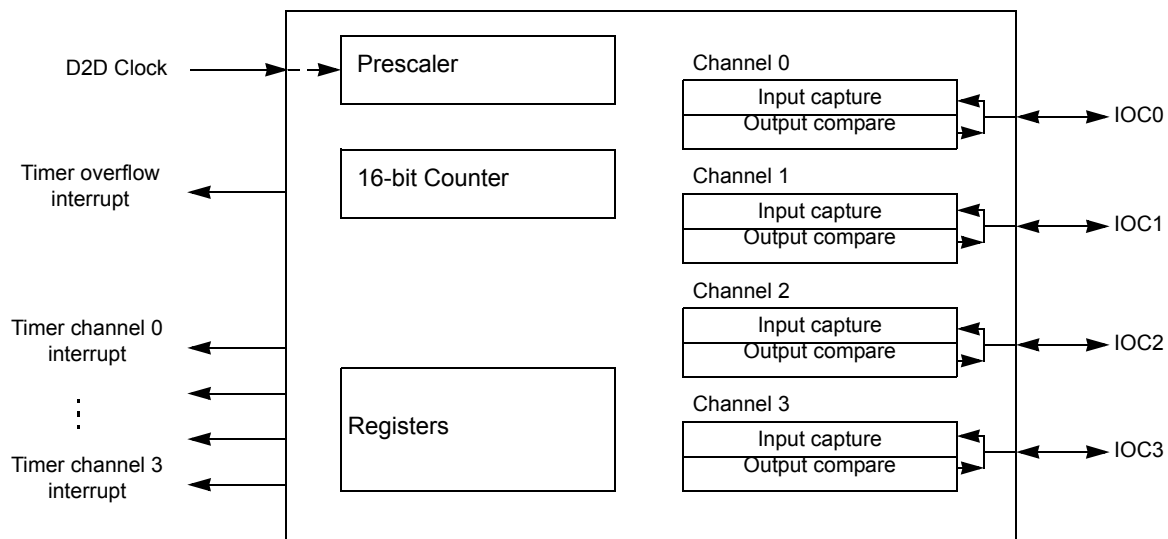

Figure 36. Timer Block Diagram

For more information see the respective functional descriptions see [Section 4.18.4, "Functional Description"](#) of this chapter.

### 4.18.2 Signal Description

#### 4.18.2.1 Overview

The TIM16B4C module is internally connected to the PTB (IOC0, IOC1, IOC2) and to the Rx signal as specified in [Section 4.17, "General Purpose I/O - PTB\[0...2\]"](#) (IOC3).

## 4.18.2.2 Detailed Signal Descriptions

### 4.18.2.2.1 IOC3 – Input Capture and Output Compare Channel 3

#### NOTE

Since the Rx signal is only available as an input, using the output compare feature for this channel would have no effect.

This pin serves as input capture or output compare for channel 3 and is internally connected to the Rx signal as specified in [Section 4.17.2, “Alternative SCI / LIN Functionality”](#).

### 4.18.2.2.2 IOC2 – Input Capture and Output Compare Channel 2

This pin serves as an input capture or output compare for channel 2 and can be routed to the PTB2 general purpose I/O.

### 4.18.2.2.3 IOC1 – Input Capture and Output Compare Channel 1

This pin serves as an input capture or output compare for channel 1 and can be routed to the PTB1 general purpose I/O.

### 4.18.2.2.4 IOC0 – Input Capture and Output Compare Channel 0

#### NOTE

For the description of interrupts see [Section 4.18.6, “Interrupts”](#).

This pin serves as an input capture or output compare for channel 0 and can be routed to the PTB0 general purpose I/O.

## 4.18.3 Memory Map and Registers

### 4.18.3.1 Overview

This section provides a detailed description of all memory and registers.

### 4.18.3.2 Module Memory Map

The memory map for the TIM16B4C module is given below in [Table 151](#).

**Table 151. Module Memory Map**

Offset <sup>(114)</sup>	Use	Access
0xC0	Timer Input Capture/Output Compare Select (TIOS)	Read/Write
0xC1	Timer Compare Force Register (CFORC)	Read/Write <sup>(115)</sup>
0xC2	Output Compare 3 Mask Register (OC3M)	Read/Write
0xC3	Output Compare 3 Data Register (OC3D)	Read/Write
0xC4	Timer Count Register (TCNT(hi))	Read/Write <sup>(116)</sup>
0xC5	Timer Count Register (TCNT(lo))	Read/Write <sup>(115)</sup>
0xC6	Timer System Control Register 1 (TSCR1)	Read/Write
0xC7	Timer Toggle Overflow Register (TTOV)	Read/Write
0xC8	Timer Control Register 1 (TCTL1)	Read/Write
0xC9	Timer Control Register 2 (TCTL2)	Read/Write
0xCA	Timer Interrupt Enable Register (TIE)	Read/Write
0xCB	Timer System Control Register 2 (TSCR2)	Read/Write
0xCC	Main Timer Interrupt Flag 1 (TFLG1)	Read/Write
0xCD	Main Timer Interrupt Flag 2 (TFLG2)	Read/Write

**Table 151. Module Memory Map (continued)**

Offset <sup>(114)</sup>	Use	Access
0xCE	Timer Input Capture/Output Compare Register 0 (TC0(hi))	Read/Write <sup>(117)</sup>
0xCF	Timer Input Capture/Output Compare Register 0 (TC0(lo))	Read/Write <sup>(116)</sup>
0xD0	Timer Input Capture/Output Compare Register 1 (TC1(hi))	Read/Write <sup>(116)</sup>
0xD1	Timer Input Capture/Output Compare Register 1 (TC1(lo))	Read/Write <sup>(116)</sup>
0xD2	Timer Input Capture/Output Compare Register 2 (TC2(hi))	Read/Write <sup>(116)</sup>
0xD3	Timer Input Capture/Output Compare Register 2 (TC2(lo))	Read/Write <sup>(116)</sup>
0xD4	Timer Input Capture/Output Compare Register 3 (TC3(hi))	Read/Write <sup>(116)</sup>

Note:

114. Offset related to 0x0200 for blocking access and 0x300 for non blocking access within the global address space.

115. Always read \$00.

116. Only writable in special modes. (Refer to SOC Guide for different modes).

117. Write to these registers have no meaning or effect during input capture.

### 4.18.3.3 Register Descriptions

This section consists of register descriptions in address order. Each description includes a standard register diagram with an associated figure number. Details of register bit and field function follow the register diagrams, in bit order.

#### 4.18.3.3.1 Timer Input Capture/Output Compare Select (TIOS)

**Table 152. Timer Input Capture/Output Compare Select (TIOS)**

Offset <sup>(118)</sup>	Access: User read/write							
0xC0	7	6	5	4	3	2	1	0
R	0	0	0	0	IOS3	IOS2	IOS1	IOS0
W								
Reset	0	0	0	0	0	0	0	0

Note:

118. Offset related to 0x0200 for blocking access and 0x300 for non blocking access within the global address space.

**Table 153. TIOS - Register Field Descriptions**

Field	Description
3-0 IOS[3-0]	Input Capture or Output Compare Channel Configuration 0 - The corresponding channel acts as an input capture. 1 - The corresponding channel acts as an output compare.

#### 4.18.3.3.2 Timer Compare Force Register (CFORC)

**Table 154. Timer Compare Force Register (CFORC)**

Offset <sup>(119)</sup>	Access: User read/write							
0xC1	7	6	5	4	3	2	1	0
R	0	0	0	0	0	0	0	0
W					FOC3	FOC2	FOC1	FOC0
Reset	0	0	0	0	0	0	0	0

Note:

119. Offset related to 0x0200 for blocking access and 0x300 for non blocking access within the global address space.

**Table 155. CFORC - Register Field Descriptions**

Field	Description
3-0 FOC[3-0]	Force Output Compare Action for Channel 3-0 0 - Force Output Compare Action disabled. Input Capture or Output Compare Channel Configuration 1 - Force Output Compare Action enabled

**NOTE**

A successful channel 3 output compare overrides any channel 2:0 compares. If forced output compare on any channel occurs at the same time as the successful output compare then forced output compare action takes precedence and interrupt flag does not get set.

A write to this register with the corresponding (FOC 3:0) data bit(s) set causes the action programmed for output compare on channel “n” to occur immediately. The action taken is the same as if a successful comparison had just taken place with the TCn register except the interrupt flag does not get set.

**4.18.3.3.3 Output Compare 3 Mask Register (OC3M)**

**NOTE**

A successful channel 3 output compare overrides any channel 2:0 compares. For each OC3M bit set, the output compare action reflects the corresponding OC3D bit

**Table 156. Output Compare 3 Mask Register (OC3M)**

Offset<sup>(120)</sup> 0xC2 Access: User read/write

	7	6	5	4	3	2	1	0
R	0	0	0	0	OC3M3	OC3M2	OC3M1	OC3M0
W								
Reset	0	0	0	0	0	0	0	0

Note:

120. Offset related to 0x0200 for blocking access and 0x300 for non blocking access within the global address space.

**Table 157. OC3M - Register Field Descriptions**

Field	Description
3-0 OC3M[3-0]	Output Compare 3 Mask “n” Channel bit 0 - Does not set the corresponding port to be an output port 1 - Sets the corresponding port to be an output port when this corresponding TIOS bit is set to be an output compare

Setting the OC3Mn (n ranges from 0 to 2) sets the corresponding port to be an output port when the corresponding TIOSn (n ranges from 0 to 2) bit is set to be an output compare.

**4.18.3.3.4 Output Compare 3 Data Register (OC3D)**

**NOTE**

A channel 3 output compare causes bits in the output compare 3 data register to transfer to the timer port data register if the corresponding output compare 3 mask register bits are set.

**Table 158. Output Compare 3 Data Register (OC3D)**

Offset<sup>(121)</sup> 0xC3 Access: User read/write

	7	6	5	4	3	2	1	0
R	0	0	0	0	OC3D3	OC3D2	OC3D1	OC3D0
W								
Reset	0	0	0	0	0	0	0	0

Note:

121. Offset related to 0x0200 for blocking access and 0x300 for non blocking access within the global address space.

**Table 159. OC3D - Register Field Descriptions**

Field	Description
3-0 OC3D[3-0]	Output Compare 3 Data for Channel “n”

**4.18.3.3.5 Timer Count Register (TCNT)**
**NOTE**

The 16-bit main timer is an up counter. A full access for the counter register should take place in one clock cycle. A separate read/write for high byte and low byte gives a different result than accessing them as a word. The period of the first count after a write to the TCNT registers may be a different length because the write is not synchronized with the prescaler clock.

**Table 160. Timer Count Register (TCNT)**

Offset <sup>(122)</sup> 0xC4, 0xC5		Access: User read(anytime)/write (special mode)							
		15	14	13	12	11	10	9	8
R		tcnt15	tcnt14	tcnt13	tcnt12	tcnt11	tcnt10	tcnt9	tcnt8
W									
Reset		0	0	0	0	0	0	0	0
		7	6	5	4	3	2	1	0
R		tcnt7	tcnt6	tcnt5	tcnt4	tcnt3	tcnt2	tcnt1	tcnt0
W									
Reset		0	0	0	0	0	0	0	0

Note:

122. Offset related to 0x0200 for blocking access and 0x300 for non blocking access within the global address space.

**Table 161. TCNT - Register Field Descriptions**

Field	Description
15-0 tcnt[15-0]	16 Bit Timer Count Register

**4.18.3.3.6 Timer System Control Register 1 (TSCR1)**
**Table 162. Timer System Control Register 1 (TSCR1)**

Offset <sup>(123)</sup> 0xC6		Access: User read/write							
		7	6	5	4	3	2	1	0
R		TEN	0	0	TFFCA	0	0	0	0
W									
Reset		0	0	0	0	0	0	0	0

Note:

123. Offset related to 0x0200 for blocking access and 0x300 for non blocking access within the global address space.

**Table 163. TSCR1 - Register Field Descriptions**

Field	Description
7 TEN	Timer Enable 1 = Enables the timer. 0 = Disables the timer. (Used for reducing power consumption).
4 TFFCA	Timer Fast Flag Clear All 1 = For TFLG1 register, a read from an input capture or a write to the output compare channel [TC 3:0] causes the corresponding channel flag, CnF, to be cleared. For TFLG2 register, any access to the TCNT register clears the TOF flag. Any access to the PACNT registers clears the PAOVF and PAIF bits in the PAFLG register. This has the advantage of eliminating software overhead in a separate clear sequence. Extra care is required to avoid accidental flag clearing due to unintended accesses. 0 = Allows the timer flag clearing.

#### 4.18.3.3.7 Timer Toggle On Overflow Register 1 (TTOV)

##### NOTE

TOVn toggles output compare pin on overflow. This feature only takes effect when the corresponding channel is configured for an output compare mode. When set, an overflow toggle on the output compare pin takes precedence over forced output compare events.

**Table 164. Timer Toggle On Overflow Register 1 (TTOV)**

Offset <sup>(124)</sup> 0xC7		Access: User read/write							
		7	6	5	4	3	2	1	0
R		0	0	0	0	TOV3	TOV2	TOV1	TOV0
W									
Reset		0	0	0	0	0	0	0	0

Note:

124. Offset related to 0x0200 for blocking access and 0x300 for non blocking access within the global address space.

**Table 165. TTOV - Register Field Descriptions**

Field	Description
3-0 TOV[3-0]	Toggle On Overflow Bits 1 = Toggle output compare pin on overflow feature enabled. 0 = Toggle output compare pin on overflow feature disabled.

#### 4.18.3.3.8 Timer Control Register 1 (TCTL1)

##### NOTE

These four pairs of control bits are encoded to specify the output action to be taken as a result of a successful Output Compare on “n” channel. When either OMn or OLn, the pin associated with the corresponding channel becomes an output tied to its IOC. To enable output action by the OMn and OLn bits on a timer port, the corresponding bit in OC3M should be cleared.

**Table 166. Timer Control Register 1 (TCTL1)**

Offset <sup>(125)</sup> 0xC8		Access: User read/write							
		7	6	5	4	3	2	1	0
R		OM3	OL3	OM2	OL2	OM1	OL1	OM0	OL0
W									
Reset		0	0	0	0	0	0	0	0

Note:

125. Offset related to 0x0200 for blocking access and 0x300 for non blocking access within the global address space.

**Table 167. TCTL1 - Register Field Descriptions**

Field	Description
7,5,3,1 OMn	Output Mode bit
6,4,2,0 OLn	Output Level bit

**Table 168. Compare Result Output Action**

OMn	OLn	Action
0	0	Timer disconnected from output pin logic
0	1	Toggle OCn output line
1	0	Clear OCn output line to zero
1	1	Set OCn output line to one

#### 4.18.3.3.9 Timer Control Register 2 (TCTL2)

**Table 169. Timer Control Register 2 (TCTL2)**

Offset 0xC9		Access: User read/write							
		7	6	5	4	3	2	1	0
R		EDG3B	EDG3A	EDG2B	EDG2A	EDG1B	EDG1A	EDG0B	EDG0A
W									
Reset		0	0	0	0	0	0	0	0

Note:

 126. <sup>(126)</sup>Offset related to 0x0200 for blocking access and 0x300 for non blocking access within the global address space.

**Table 170. TCTL2 - Register Field Descriptions**

Field	Description
EDGnB,EDGnA	Input Capture Edge Control

These four pairs of control bits configure the input capture edge detector circuits.

**Table 171. Edge Detector Circuit Configuration**

EDGnB	EDGnA	Configuration
0	0	Capture disabled
0	1	Capture on rising edges only
1	0	Capture on falling edges only
1	1	Capture on any edge (rising or falling)

### 4.18.3.3.10 Timer Interrupt Enable Register (TIE)

**Table 172. Timer Interrupt Enable Register (TIE)**

Offset<sup>(127)</sup> 0xCA Access: User read/write

	7	6	5	4	3	2	1	0
R	0	0	0	0	C3I	C2I	C1I	C0I
W								
Reset	0	0	0	0	0	0	0	0

Note:

127. Offset related to 0x0200 for blocking access and 0x300 for non blocking access within the global address space.

**Table 173. TIE - Register Field Descriptions**

Field	Description
3-0 C[3-0]I	Input Capture/Output Compare Interrupt Enable. 1 = Enables corresponding Interrupt flag (CnF of TFLG1 register) to cause a hardware interrupt 0 = Disables corresponding Interrupt flag (CnF of TFLG1 register) from causing a hardware interrupt

### 4.18.3.3.11 Timer System Control Register 2 (TSCR2)

**NOTE**

This mode of operation is similar to an up-counting modulus counter.

If register TC3 = \$0000 and TCRE = 1, the timer counter register (TCNT) stays at \$0000 continuously. If register TC3 = \$FFFF and TCRE = 1, TOF does not set when the timer counter register (TCNT) is reset from \$FFFF to \$0000.

The newly selected prescale factor does not take effect until the next synchronized edge, where all prescale counter stages equal zero.

**Table 174. Timer System Control Register 2 (TSCR2)**

Offset<sup>(128)</sup> 0xCB Access: User read/write

	7	6	5	4	3	2	1	0
R	TOI	0	0	0	TCRE	PR2	PR1	PR0
W								
Reset	0	0	0	0	0	0	0	0

Note:

128. Offset related to 0x0200 for blocking access and 0x300 for non blocking access within the global address space.

**Table 175. TIE - Register Field Descriptions**

Field	Description
7 TOI	Timer Overflow Interrupt Enable 1 = Hardware interrupt requested when TOF flag set in TFLG2 register. 0 = Hardware Interrupt request inhibited.
3 TCRE	TCRE — Timer Counter Reset Enable 1 = Enables Timer Counter reset by a successful output compare on channel 3 0 = Inhibits Timer Counter reset and counter continues to run.
3-0 PR[2:0]	Timer Prescaler Select These three bits select the frequency of the timer prescaler clock derived from the Bus Clock as shown in <a href="#">Table 176</a> .

**Table 176. Timer Clock Selection**

PR2	PR1	PR0	Timer Clock
0	0	0	D2D Clock / 1
0	0	1	D2D Clock / 2
0	1	0	D2D Clock / 4
0	1	1	D2D Clock / 8
1	0	0	D2D Clock / 16
1	0	1	D2D Clock / 32
1	1	0	D2D Clock / 64
1	1	1	D2D Clock / 128

#### 4.18.3.3.12 Main Timer Interrupt Flag 1 (TFLG1)

**NOTE**

These flags are set when an input capture or output compare event occurs. Flag set on a particular channel is cleared by writing a one to the corresponding CnF bit. Writing a zero to CnF bit has no effect on its status. When TFFCA bit in TSCR register is set, a read from an input capture or a write into an output compare channel causes the corresponding channel flag CnF to be cleared.

**Table 177. Main Timer Interrupt Flag 1 (TFLG1)**

 Offset<sup>(129)</sup> 0xCC

Access: User read/write

	7	6	5	4	3	2	1	0
R	0	0	0	0	C3F	C2F	C1F	C0F
W								
Reset	0	0	0	0	0	0	0	0

Note:

129. Offset related to 0x0200 for blocking access and 0x300 for non blocking access within the global address space.

**Table 178. TFLG1 - Register Field Descriptions**

Field	Description
3-0 C[3:0]F	Input Capture/Output Compare Channel Flag. 1 = Input Capture or Output Compare event occurred 0 = No event (Input Capture or Output Compare event) occurred.

#### 4.18.3.3.13 Main Timer Interrupt Flag 2 (TFLG2)

**NOTE**

The TFLG2 register indicates when an interrupt has occurred. Writing a one to the TOF bit clears it. Any access to TCNT clears TOF bit of TFLG2 register if the TFFCA bit in TSCR register is set.

**Table 179. Main Timer Interrupt Flag 2 (TFLG2)**

 Offset<sup>(130)</sup> 0xCD

Access: User read/write

	7	6	5	4	3	2	1	0
R	TOF	0	0	0	0	0	0	0
W								
Reset	0	0	0	0	0	0	0	0

Note:

130. Offset related to 0x0200 for blocking access and 0x300 for non blocking access within the global address space.

**Table 180. TFLG2 - Register Field Descriptions**

Field	Description
7 TOF	Timer Overflow Flag 1 = Indicates an Interrupt has occurred (Set when 16-bit free-running timer counter overflows from \$FFFF to \$0000) 0 = Flag indicates an Interrupt has not occurred.

**4.18.3.3.14 Timer Input Capture/Output Compare Registers (TC3 - TC0)**

**NOTE**

TRead anytime. Write anytime for output compare function. Writes to these registers have no effect during input capture.

Depending on the TIOS bit for the corresponding channel, these registers are used to latch the value of the free-running counter when a defined transition is sensed by the corresponding input capture edge detector or to trigger an output action for output compare.

Read/Write access in byte mode for high byte should takes place before low byte otherwise it gives a different result.

**Table 181. Timer Input Capture/Output Compare Register 0 (TC0)**

Offset<sup>(131)</sup> 0xCE, 0xCF Access: User read(anytime)/write (special mode)

	15	14	13	12	11	10	9	8
R	tc0_15	tc0_14	tc0_13	tc0_12	tc0_11	tc0_10	tc0_9	tc0_8
W								
Reset	0	0	0	0	0	0	0	0
	7	6	5	4	3	2	1	0
R	tc0_7	tc0_6	tc0_5	tc0_4	tc0_3	tc0_2	tc0_1	tc0_0
W								
Reset	0	0	0	0	0	0	0	0

Note:

131. Offset related to 0x0200 for blocking access and 0x300 for non blocking access within the global address space.

**Table 182. Timer Input Capture/Output Compare Register 1(TC1)**

Offset<sup>(132)</sup> 0xD0, 0xD1 Access: User read(anytime)/write (special mode)

	15	14	13	12	11	10	9	8
R	tc1_15	tc1_14	tc1_13	tc1_12	tc1_11	tc1_10	tc1_9	tc1_8
W								
Reset	0	0	0	0	0	0	0	0
	7	6	5	4	3	2	1	0
R	tc1_7	tc1_6	tc1_5	tc1_4	tc1_3	tc1_2	tc1_1	tc1_0
W								
Reset	0	0	0	0	0	0	0	0

Note:

132. Offset related to 0x0200 for blocking access and 0x300 for non blocking access within the global address space.

**Table 183. Timer Input Capture/Output Compare Register 2(TC2)**

Offset <sup>(133)</sup> 0xD2, 0xD3		Access: User read(anytime)/write (special mode)							
		15	14	13	12	11	10	9	8
R		tc2_15	tc2_14	tc2_13	tc2_12	tc2_11	tc2_10	tc2_9	tc2_8
W									
Reset		0	0	0	0	0	0	0	0
		7	6	5	4	3	2	1	0
R		tc2_7	tc2_6	tc2_5	tc2_4	tc2_3	tc2_2	tc2_1	tc2_0
W									
Reset		0	0	0	0	0	0	0	0

Note:

133. Offset related to 0x0200 for blocking access and 0x300 for non blocking access within the global address space.

**Table 184. Timer Input Capture/Output Compare Register 3(TC3)**

Offset <sup>(134)</sup> 0xD4, 0xD5		Access: User read(anytime)/write (special mode)							
		15	14	13	12	11	10	9	8
R		tc3_15	tc3_14	tc3_13	tc3_12	tc3_11	tc3_10	tc3_9	tc3_8
W									
Reset		0	0	0	0	0	0	0	0
		7	6	5	4	3	2	1	0
R		tc3_7	tc3_6	tc3_5	tc3_4	tc3_3	tc3_2	tc3_1	tc3_0
W									
Reset		0	0	0	0	0	0	0	0

Note:

134. Offset related to 0x0200 for blocking access and 0x300 for non blocking access within the global address space.

**Table 185. TCn - Register Field Descriptions**

Field	Description
15-0 tcn[15-0]	16 Timer Input Capture/Output Compare Registers

**4.18.4 Functional Description**

**4.18.4.1 General**

This section provides a complete functional description of the timer TIM16B4C block. Refer to the detailed timer block diagram in [Figure 37](#) as necessary.

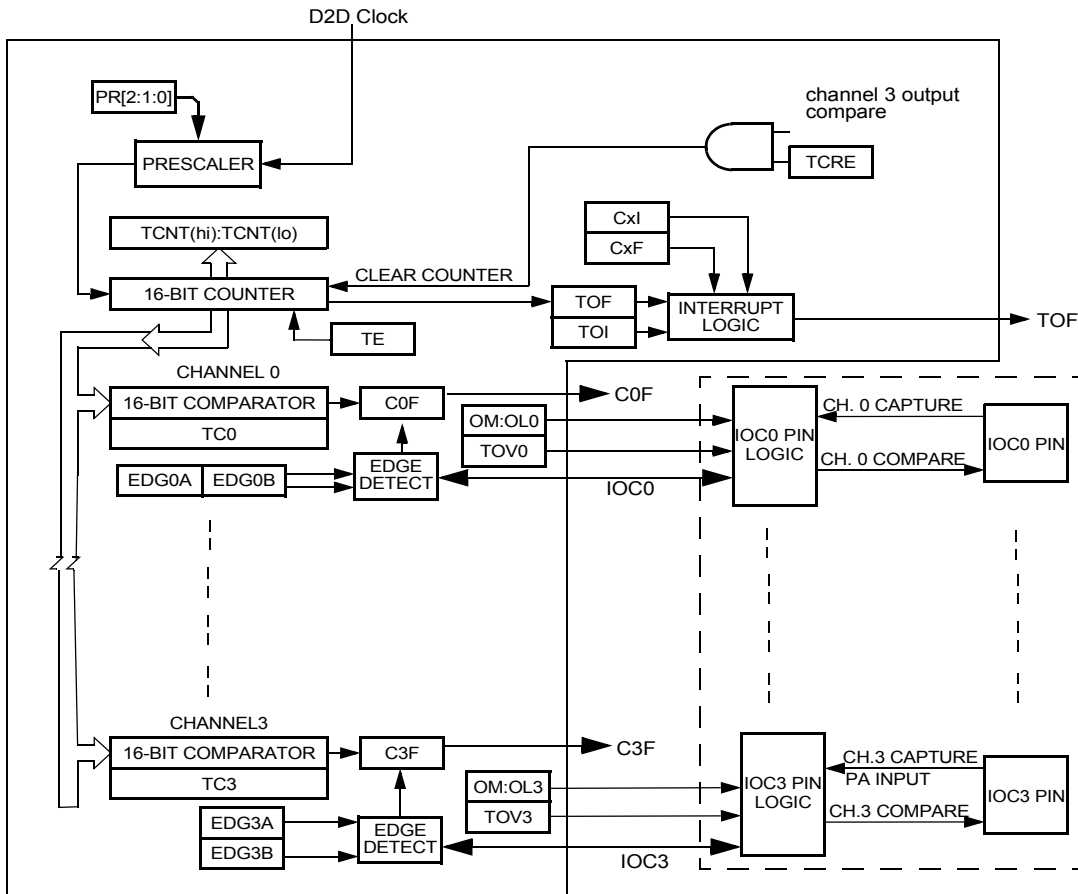

**Figure 37. Detailed Timer Block Diagram**

**4.18.4.2 Prescaler**

The prescaler divides the bus clock by 1, 2, 4, 8, 16, 32, 64, or 128. The prescaler select bits, PR[2:0], select the prescaler divisor. PR[2:0] are in the timer system control register 2 (TSCR2).

**4.18.4.3 Input Capture**

Clearing the I/O (input/output) select bit, IOSn, configures channel n as an input capture channel. The input capture function captures the time at which an external event occurs. When an active edge occurs on the pin of an input capture channel, the timer transfers the value in the timer counter into the timer channel registers, TCn. The minimum pulse width for the input capture input is greater than two bus clocks. An input capture on channel n sets the CnF flag. The CnI bit enables the CnF flag to generate interrupt requests.

**4.18.4.4 Output Compare**

Setting the I/O select bit, IOSn, configures channel n as an output compare channel. The output compare function can generate a periodic pulse with a programmable polarity, duration, and frequency. When the timer counter reaches the value in the channel registers of an output compare channel, the timer can set, clear, or toggle the channel pin. An output compare on channel n sets the CnF flag. The CnI bit enables the CnF flag to generate interrupt requests.

The output mode and level bits, OMn and OLn, select set, clear, toggle on output compare. Clearing both OMn and OLn disconnects the pin from the output logic. Setting a force output compare bit, FOCn, causes an output compare on channel n. A forced output compare does not set the channel flag.

A successful output compare on channel 3 overrides output compares on all other output compare channels. The output compare 3 mask register masks the bits in the output compare 3 data register. The timer counter reset enable bit, TCRE, enables channel 3 output compares to reset the timer counter. A channel 3 output compare can reset the timer counter even if the IOC3 pin is being used as the pulse accumulator input.

Writing to the timer port bit of an output compare pin does not affect the pin state. The value written is stored in an internal latch. When the pin becomes available for general-purpose output, the last value written to the bit appears at the pin.

## 4.18.5 Resets

### 4.18.5.1 General

The reset state of each individual bit is listed within the Register Description section 4.18.3, “Memory Map and Registers”, which details the registers and their bit-fields.

## 4.18.6 Interrupts

### 4.18.6.1 General

This section describes interrupts originated by the TIM16B4C block. Table 186 lists the interrupts generated by the TIM16B4C to communicate with the MCU.

**Table 186. TIM16B4C Interrupts**

Interrupt	Offset	Vector	Priority	Source	Description
C[3:0]F	-	-	-	Timer Channel 3-0	Active high timer channel interrupts 3-0
TOF	-	-	-	Timer Overflow	Timer Overflow interrupt

### 4.18.6.2 Description of Interrupt Operation

The TIM16B4C uses a total of 5 interrupt vectors. The interrupt vector offsets and interrupt numbers are chip dependent. More information on interrupt vector offsets and interrupt numbers can be found in the Section 4.6, “Interrupts”

#### 4.18.6.2.1 Channel [3:0] Interrupt

These active high outputs are asserted by the module to request a timer channel 3–0 interrupt, following an input capture or output compare event on these channels [3-0]. For the interrupt to be asserted on a specific channel, the enable, CnI bit of TIE register should be set. These interrupts are serviced by the system controller.

#### 4.18.6.2.2 Timer Overflow Interrupt (TOF)

This active high output is asserted by the module to request a timer overflow interrupt, following the timer counter overflow when the overflow enable bit (TOI) bit of TFLG2 register is set. This interrupt is serviced by the system controller.

## 4.19 Analog Digital Converter - ADC

### 4.19.1 Introduction

#### 4.19.1.1 Overview

In order to sample the MM912F634 analog die analog sources, a 10-bit resolution successive approximation Analog to Digital Converter has been implemented. Controlled by the A/D Control Logic (ADC Wrapper), the Analog Digital Converter allows fast and high precision conversions.

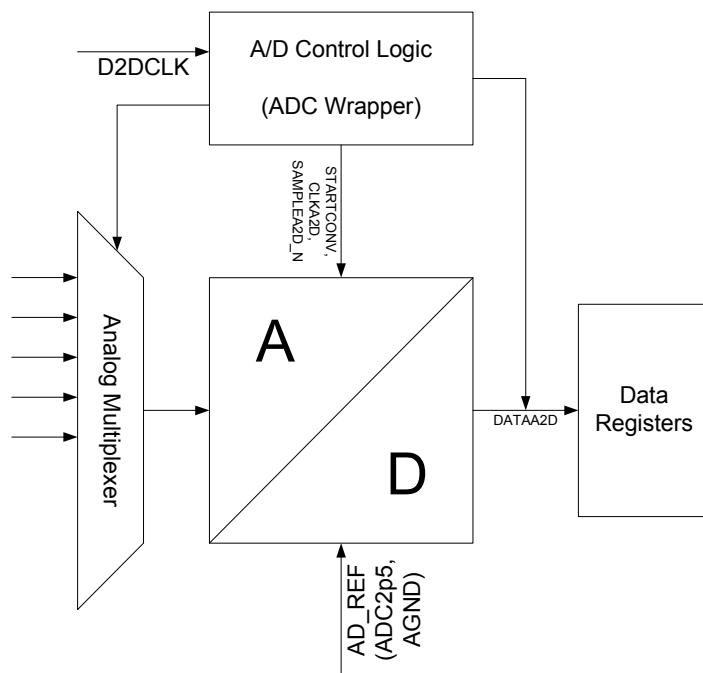

Figure 38. Analog Digital Converter Block Diagram

**4.19.1.2 Features**

- 10-bit resolution
- 13  $\mu$ s (typ.), 10-bit Single Sample + Conversion Time
- External ADC2p5 pin with overcurrent protection to filter the analog reference voltage
- Total Error (TE) of  $\pm 5$  LSB without offset calibration active
- Integrated selectable offset compensation
- 14 + 1 analog channels (AD0...8; ISENSE, TSENSE and VSENSE, VS1SENSE, BANDGAP, plus calibration channel)
- Sequence- and Continuous Conversion Mode with IRQ for Sequence Complete indication
- Dedicated Result register for each channel

**4.19.2 Modes of Operation**

The Analog Digital Converter Module is active only in normal mode; it is disabled in Sleep and Stop mode.

**4.19.3 External Signal Description**

This section lists and describes the signals connected off-chip. Table 187 shows all the pins and their functions controlled by the Analog Digital Converter Module.

Table 187. ADC - Pin Functions and Priorities

Pin Name	Pin Function & Priority	I/O	Description	Pin Function after Reset
AGND	Analog Ground	-	Analog Ground Connection	-
ADC2p5	Analog Regulator	-	Analog Digital Converter Regulator Filter Terminal. A capacitor $C_{ADC2p5}$ is required for operation.	-

## 4.19.4 Memory Map and Register Definition

### 4.19.4.1 Module Memory Map

Table 188 shows the register map of the Analog Digital Converter Module. All Register addresses given are referenced to the D2D interface offset.

**Table 188. Analog Digital Converter Module - Memory Map**

Register / Offset <sup>(135)</sup>		Bit 7	6	5	4	3	2	1	Bit 0
0x80 ACR	R	SCIE	CCE	OCE	ADCRST	0	PS2	PS1	PS0
	W								
0x81 ASR	R	SCF	2p5CLF	0	0	CCNT3	CCNT2	CCNT1	CCNT0
	W								
0x82 ACCR (hi)	R	CH15	CH14	0	CH12	CH11	CH10	CH9	CH8
	W								
0x83 ACCR (lo)	R	CH7	CH6	CH5	CH4	CH3	CH2	CH1	CH0
	W								
0x84 ACCSR (hi)	R	CC15	CC14	0	CC12	CC11	CC10	CC9	CC8
	W								
0x85 ACCSR (lo)	R	CC7	CC6	CC5	CC4	CC3	CC2	CC1	CC0
	W								
0x86 ADR0 (hi)	R	ADR0[9:2]							
	W								
0x87 ADR0 (lo)	R	ADR0[1:0]							
	W								
0x88 ADR1 (hi)	R	ADR1[9:2]							
	W								
0x89 ADR1 (lo)	R	ADR1[1:0]							
	W								
0x8A ADR2 (hi)	R	ADR2[9:2]							
	W								
0x8B ADR2 (lo)	R	ADR2[1:0]							
	W								
0x8C ADR3 (hi)	R	ADR3[9:2]							
	W								
0x8D ADR3 (lo)	R	ADR3[1:0]							
	W								
0x8E ADR4 (hi)	R	ADR4[9:2]							
	W								
0x8F ADR4 (lo)	R	ADR4[1:0]							
	W								

**Table 188. Analog Digital Converter Module - Memory Map (continued)**

Register / Offset <sup>(135)</sup>		Bit 7	6	5	4	3	2	1	Bit 0
0x90	R	ADR5[9:2]							
ADR5 (hi)	W								
0x91	R	ADR5[1:0]							
ADR5 (lo)	W								
0x92	R	ADR6[9:2]							
ADR6 (hi)	W								
0x93	R	ADR6[1:0]							
ADR6 (lo)	W								
0x94	R	ADR7[9:2]							
ADR7 (hi)	W								
0x95	R	ADR7[1:0]							
ADR7 (lo)	W								
0x96	R	ADR8[9:2]							
ADR8 (hi)	W								
0x97	R	ADR8[1:0]							
ADR8 (lo)	W								
0x98	R	ADR9[9:2]							
ADR9 (hi)	W								
0x99	R	ADR9[1:0]							
ADR9 (lo)	W								
0x9A	R	ADR10[9:2]							
ADR10 (hi)	W								
0x9B	R	ADR10[1:0]							
ADR10 (lo)	W								
0x9C	R	ADR11[9:2]							
ADR11 (hi)	W								
0x9D	R	ADR11[1:0]							
ADR11 (lo)	W								
0x9E	R	ADR12[9:2]							
ADR12 (hi)	W								
0x9F	R	ADR12[1:0]							
ADR12 (lo)	W								
0xA0	R								
Reserved	W								
0xA1	R								
Reserved	W								
0xA2	R	ADR14[9:2]							
ADR14 (hi)	W								

**Table 188. Analog Digital Converter Module - Memory Map (continued)**

Register / Offset <sup>(135)</sup>		Bit 7	6	5	4	3	2	1	Bit 0
0xA3	R	ADR14[1:0]							
ADR14 (lo)	W								
0xA4	R	ADR15[9:2]							
ADR15 (hi)	W								
0xA5	R	ADR15[1:0]							
ADR15 (lo)	W								

Note:  
135. Offset related to 0x0200 for blocking access and 0x300 for non blocking access within the global address space.

**4.19.4.2 Register Definition**

**4.19.4.2.1 ADC Config Register (ACR)**

**NOTE**

ADCRST is strongly recommended to be set during D2D clock frequency changes.

**Table 189. ADC Config Register (ACR)**

Offset <sup>(136)</sup>	Access: User read/write							
0x80	7	6	5	4	3	2	1	0
R	SCIE	CCE	OCE	ADCRST	0	PS2	PS1	PS0
W								
Reset	0	0	0	0	0	0	0	0

Note:  
136. Offset related to 0x0200 for blocking access and 0x300 for non blocking access within the global address space.

**Table 190. ACR - Register Field Descriptions**

Field	Description
7 - SCIE	Sequence Complete Interrupt Enable 0 - Sequence Complete Interrupt Disabled 1 - Sequence Complete Interrupt Enabled
6 - CCE	Continuous Conversion Enable 0 - Continuous Conversion Disabled 1 - Continuous Conversion Enabled
5 - OCE	Offset Compensation Enable 0 - Offset Compensation Disabled 1 - Offset Compensation Enabled, This feature requires the CH15 bit in the ADC Conversion Control Register (ACCR) to be set for all conversions.

**Table 190. ACR - Register Field Descriptions (continued)**

Field	Description
4 - ADCRST	Analog Digital Converter RESET 0 - Analog Digital Converter in Normal Operation 1 - Analog Digital Converter in Reset Mode, all ADC registers resets to initial values. The bit has to be cleared to allow ADC operation.
2-0 PS2...0	ADC Clock Prescaler Select (D2DCLK to ADCCLK divider) 000 - 10 001 - 8 010 - 6 011 - 4 100 - 2 101 - 1 110 - 1 111 - 1

**4.19.4.2.2 ADC Status Register (ASR)**

**Table 191. ADC Status Register (ASR)**

Offset<sup>(137)</sup> 0x81 Access: User read/write

	7	6	5	4	3	2	1	0
R	SCF	2p5CLF	0	0	CCNT3	CCNT2	CCNT1	CCNT0
W								
Reset	0	0	0	0	1	1	1	1

Note:  
137. Offset related to 0x0200 for blocking access and 0x300 for non blocking access within the global address space.

**Table 192. ACR - Register Field Descriptions**

Field	Description
7 - SCF	Sequence Complete Flag. Reading the ADC Status Register (ASR) clears the Flag.
6 - 2p5CLF	ADC Reference Voltage Current Limitation Flag
3-0 CCNT3...0	Conversion Counter Status. The content of CCNT reflects the current channel in conversion and the conversion of CCNT-1 being complete. The conversion order is CH15, CH0, CH1,..., CH14.

ADC Conversion Control Register (ACCR)

**Table 193. ADC Conversion Control Register (ACCR)**

Offset<sup>(138)</sup> 0x82 (0x82 and 0x83 for 8-Bit access) Access: User read/write

	15	14	13	12	11	10	9	8	7	6	5	4	3	2	1	0
R	CH15	CH14	0	CH12	CH11	CH10	CH9	CH8	CH7	CH6	CH5	CH4	CH3	CH2	CH1	CH0
W																
Reset	0	0	0	0	0	0	0	0	0	0	0	0	0	0	0	0

Note:  
138. Offset related to 0x0200 for blocking access and 0x300 for non blocking access within the global address space.

**Table 194. ACCR - Register Field Descriptions**

Field	Description
15-0 CHx	Channel Select - If 1, the selected channel is included into the sequence. Writing ACCR stops the current sequence and restart. Writing ACCR=0 stops the conversion, All CCx flags are cleared when ACCR is written. Conversion starts after write. 16-Bit write operation recommended, writing 8-bit: Only writing the High Byte starts the conversion with Channel 15, if selected. Write to the Low Byte does not start a conversion. Measure individual Channels by writing a sequence of one channel. Channel 15 needs to be selected in order to have the offset compensation functional.

#### 4.19.4.2.3 ADC Conversion Complete Status Register (ACCSR)

**Table 195. ADC Conversion Complete Status Register (ACCSR)**

 Offset<sup>(139)</sup> 0x84 (0x84 and 0x85 for 8-Bit access)

Access: User read

	15	14	13	12	11	10	9	8	7	6	5	4	3	2	1	0
R	CC15	CC14	0	CC12	CC11	CC10	CC9	CC8	CC7	CC6	CC5	CC4	CC3	CC2	CC1	CC0
W																
Reset	0	0	0	0	0	0	0	0	0	0	0	0	0	0	0	0

Note:

139. Offset related to 0x0200 for blocking access and 0x300 for non blocking access within the global address space.

**Table 196. ACCSR - Register Field Descriptions**

Field	Description
15-0 CCx	Conversion Complete Flag - Indicates the conversion being complete for channel x. Read operation only. 16-bit read recommended. 8-Bit read returns the current status, no latching is performed.

#### 4.19.4.2.4 ADC Data Result Register x (ADRx)

**Table 197. ADC Data Result Register x (ADRx)**

 Offset<sup>(140)</sup> 0x86+x (0x86 and 0x87 for 8-Bit access)

Access: User read

	15	14	13	12	11	10	9	8	7	6	5	4	3	2	1	0	
R	ADRx											0	0	0	0	0	0
W																	
Reset	0	0	0	0	0	0	0	0	0	0	0	0	0	0	0	0	

Note:

140. Offset related to 0x0200 for blocking access and 0x300 for non blocking access within the global address space.

**Table 198. ADRx - Register Field Descriptions**

Field	Description
15-6 ADRx	ADC - Channel X left adjusted Result Register. Reading the register clears the corresponding CCx register in the ACCSR register. 16-bit read recommended. 8-Bit read: Reading the low byte latches the high byte for the next read, reading the high byte clears the cc flag.

## 4.19.5 Functional Description

### 4.19.5.1 Analog Channel Definitions

The following analog Channels are routed to the analog multiplexer:

**Table 199. Analog Channels**

Channel	Description	
0	AD0 - PTB0 Analog Input	AD0
1	AD1 - PTB1 Analog Input	AD1
2	AD2 - PTB2 Analog Input	AD2
3	AD3 - L0 Analog Input	AD3
4	AD4 - L1 Analog Input	AD4
5	AD5 - L2 Analog Input	AD5
6	AD6 - L3 Analog Input	AD6
7	AD7 - L4 Analog Input	AD7
8	AD8 - L5 Analog Input	AD8
9	Current Sense	ISENSE
10	Voltage Sense	VSENSE
11	Temperature Sense	TSENSE
12	VS1 Sense	VS1SENSE
13	not implemented	n.i.
14	Bandgap <sup>(141)</sup>	BANDGAP
15	Calibration Reference	CAL

Note:

141. Internal "bg1p25sleep" reference.

### 4.19.5.2 Automatic Offset Compensation

To eliminate the Analog Digital Converter Offset, an automatic compensation is implemented. The compensation is based on a calibrated voltage reference connected to ADC Channel 15. The reference trim is accomplished by the correct CTRx Register content. See [Section 4.25, "MM912F634 - Analog Die Trimming"](#). The reference is factory trimmed to 8 LSB.

To activate the Offset compensation feature, the OCE bit in the ADC Config Register (ACR) has to be set, and the CH15 has to be enabled when starting a new conversion, by writing to the ADC Conversion Control Register (ACCR). The compensation works with single and sequence conversion.

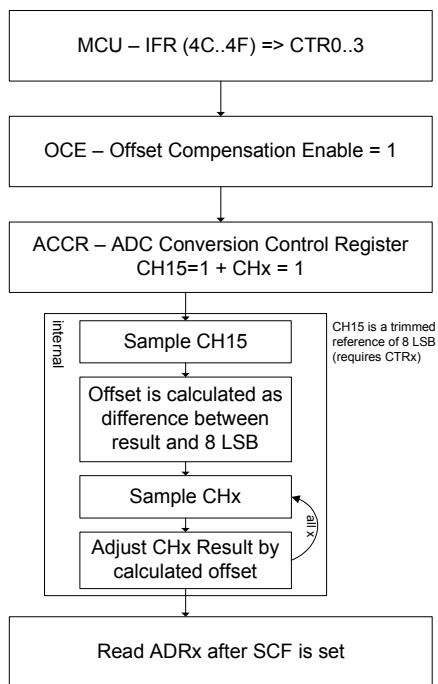

Figure 39. Automatic Offset Compensation

#### 4.19.5.3 Conversion Timing

The conversion timing is based on the ADCCLK generated by the ADC prescaler (PS) out of the D2DCLK signal. The prescaler needs to be configured to have the ADCCLK match the specified  $f_{ADC}$  clock limits. A conversion is divided into the following 27+ clock cycles:

- 9 cycle sampling time
- 18 cycle remaining conversion time
- A worst case (only channel 14) of 15 clock cycles to count up to the selected channel (15, 0, 1,...14)
- 4 cycles between two channels

##### Example 1. Single Conversion Channel 10 (VSENSE)

12c (count up to Ch10) + 9c (sample) + 18c (conversion) = 39 cycles from start to end of conversion.

##### Example 2. Sequence of Channel 10 (VSENSE) + Channel 15 (Offset Compensation)

1c (count) + 9c (sample Ch15) + 18c (conversion Ch15) + 4c (in between) + 0c (count further to Ch10 is performed while converting ch15) + 9c (sample) + 18c (conversion) = 59 cycles from start to end of both conversions.

## 4.20 Current Sense Module - ISENSE

The Current Sense Module is implemented to amplify the voltage drop across an external shunt resistor to measure the actual application current using the internal Analog Digital Converter Channel 9. Typical application is the motor current in a window lift control module

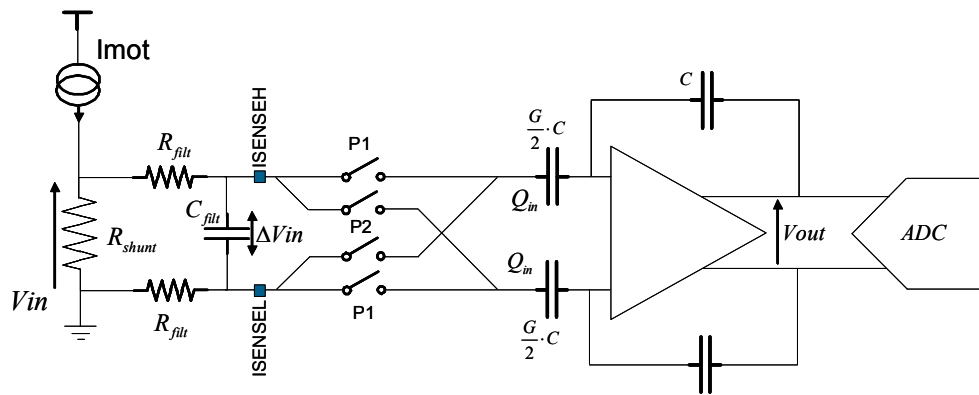

**Figure 40. Current Sense Module with External Filter Option**

The implementation is based on a switched capacitor solution to eliminate unwanted offset. To fit several application scenarios, eight different GAIN settings are implemented.

**4.20.1 Register Definition**

**4.20.1.1 Current Sense Register (CSR)**

**Table 200. Current Sense Register (CSR)**

Offset<sup>(142)</sup> 0x3C Access: User read/write

	7	6	5	4	3	2	1	0
R	CSE	0	0	0	CCD	CSGS		
W								
Reset	0	0	0	0	0	0	0	0

Note:

142. Offset related to 0x0200 for blocking access and 0x300 for non blocking access within the global address space.

**Table 201. CSR - Register Field Descriptions**

Field	Description
7 CSE	Current Sense Enable Bit 0 - Current Sense Module Disabled 1 - Current Sense Module Enabled
3 CCD	Input Filter Charge Compensation Disable Bit <sup>(143)</sup> 0 - Enabled 1 - Disabled
2-0 CSGS	Current Sense Gain Select - Selects the amplification GAIN for the current sense module 000 - 7 (typ.) 001 - 9 (typ.) 010 - 10 (typ.) 011 - 12 (typ.) 100 - 14 (typ.) 101 - 18 (typ.) 110 - 24 (typ.) 111 - 36 (typ.)

Note:

143. This feature should be used when implementing an external filter to the current sense ISENSEx inputs. In principal an internal charge compensation is activated in synch with the conversion to avoid the sample capacitors to be discharged by the external filter.

## 4.21 Temperature Sensor - TSENSE

To be able to measure the current MM912F634 analog die chip temperature, the TSENSE feature is implemented. A constant temperature related gain of  $TS_G$  can be routed to the internal Analog Digital Converter (Channel 11).

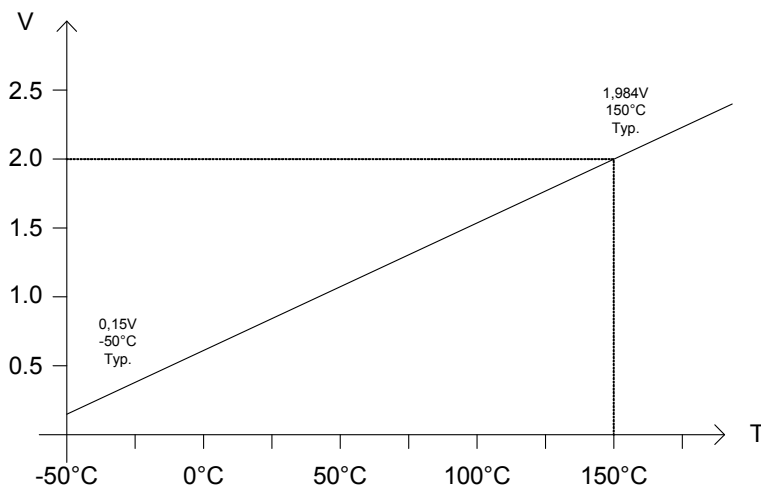

Figure 41. TSENSE - Graph

Refer to the [Section 4.19, "Analog Digital Converter - ADC"](#) for details on the channel selection and analog measurement.

## 4.22 Supply Voltage Sense - VSENSE

### NOTE

Due to internal capacitor charging, temperature measurements are valid 200 ms (max) after system power up and wake-up.

The reverse battery protected VSENSE pin has been implemented to allow a direct measurement of the Battery level voltage. Bypassing the device VSUP capacitor and external reverse battery diode detects undervoltage conditions without delay. A series resistor is required to protect the MM912F634 analog die from fast transients.

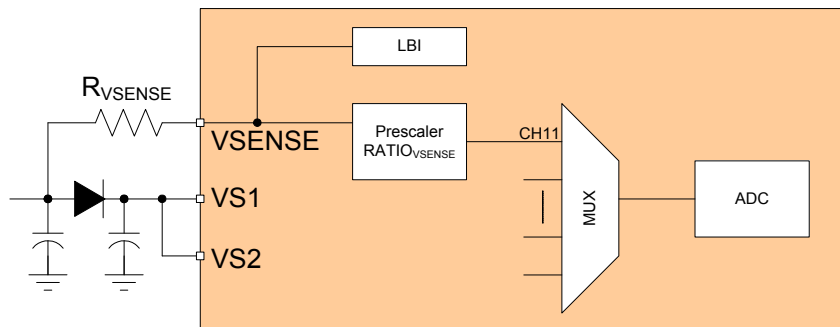

Figure 42. VSENSE Module

The voltage present on the VSENSE pin can be routed via an internal divider to the internal Analog Digital Converter or issue an interrupt (LBI) to alert the MCU.

For the interrupt based alert, see [Section 4.4, "Power Supply"](#). For VSENSE measurement using the internal ADC see [Section 4.19, "Analog Digital Converter - ADC"](#).

### 4.23 Internal Supply Voltage Sense - VS1SENSE

In addition to the VSENSE module, the internal VS1 supply can be routed to the analog digital converter as well. See Section 4.19, “Analog Digital Converter - ADC” for details on the acquisition.

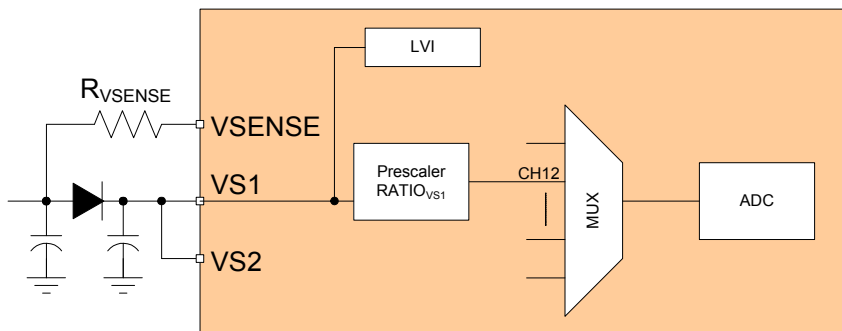

Figure 43. VS1Sense Module

### 4.24 Internal Bandgap Reference Voltage Sense - BANDGAP

The internal reference bandgap voltage “bg1p25sleep” is generated fully independent from the Analog Digital Converter reference voltages. Measuring<sup>(144)</sup> the “bg1p25sleep” reference through the ADC-CH14 allows should return a conversion result within AD<sub>CH14</sub> under normal conditions. Any result outside the range would indicate faulty behavior of either the ADC chain or the 2p5sleep Bandgap circuitry.

Note:  
 144. The maximum allowed sample frequency for Channel 14 is limited to f<sub>CH14</sub>. Increasing the sample frequency above can result in unwanted turn off of the LS drivers due to a false VREG overvoltage.

### 4.25 MM912F634 - Analog Die Trimming

A trimming option is implemented to increase accuracy of some device parameter. As the MM912F634 analog die is exclusively combined with a FLASH- MCU, the required trimming values can be calculated during the final test of the device, and stored to a fixed position in the FLASH memory. During start-up of the system, the trimming values have to be copied into the MM912F634 analog die trimming registers. The four trimming registers are completely filled (data, trim enable, trim lock for CTR2) and stored in flash memory.

During start-up of the system, complete CTRx registers have to be copied into the MM912F634 analog die trimming registers. The trimming registers maintain their contents when the device enters Low-power mode. If a RESET is asserted, the default value is set for the register contents for CTR0 and CTR1. However, the contents of the register for CTR2 is not reset to default values if the Sleep Band Gap (SLPBG) Lock Bit has been set to 1.

There is a possibility for the user to experience the unintended loading and locking of the default SLPBG trim value into CTR2 during abnormal power-up conditions. Therefore, it is recommended the user mask this Lock Bit with software during loading of the CTR2 trim values. See MM912F634, Silicon Analog Mask (M91W) / Digital Mask (M33G) Errata.

#### 4.25.1 Module Memory Map

There are four trimming registers implemented (CTR0...CTR3). The following table shows the registers used.

Table 202. MM912F634 Analog Die Trimming Registers

Offset <sup>(145)</sup>	Name		7	6	5	4	3	2	1	0
0xF0	CTR0	R	LINTRE	LINTR	WDCTRE	CTR0_4	CTR0_3	WDCTR2	WDCTR1	WDCTR0
	Trimming Reg 0	W								
0xF1	CTR1	R	BGTRE	CTR1_6	BGTRIMUP	BGTRIMDN	IREFTRE	IREFTR2	IREFTR1	IREFTR0
	Trimming Reg 1	W								

**Table 202. MM912F634 Analog Die Trimming Registers (continued)**

0xF2	CTR2	R	0	0	0	SLPBGTR0	SLPBG_LOCK	SLPBGTR2	SLPBGTR1	SLPBGTR0
	Trimming Reg 2	W								
0xF3	CTR3	R	OFFCTRE	OFFCTR2	OFFCTR1	OFFCTR0	CTR3_E	CTR3_2	CTR3_1	CTR3_0
	Trimming Reg 3	W								

Note:

145. Offset related to 0x0200 for blocking access and 0x300 for non blocking access within the global address space.

At system startup, the trimming information have to be copied from the MCU IFR Flash location to the corresponding MM912F634 analog die trimming registers. The following table shows the register correlation.

**Table 203. MM912F634 - MCU vs. Analog Die Trimming Register Correlation**

Name	MCU IFR Address	Analog Offset <sup>(146)</sup>
CTR0	0x4C	0xF0
CTR1	0x4D	0xF1
CTR2	0x4E	0xF2
CTR3	0x4F	0xF3

Note:

146. Offset related to 0x0200 for blocking access and 0x300 for non blocking access within the global address space.

## 4.25.2 Register Descriptions

### 4.25.2.1 Trimming Register 0 (CTR0)

**Table 204. Trimming Register 0 (CTR0)**

 Offset<sup>(147)</sup> 0xF0

Access: User read/write

	7	6	5	4	3	2	1	0
R								
W	LINTRE	LINTR	WDCTRE	CTR0_4	CTR0_3	WDCTR2	WDCTR1	WDCTR0
Reset	0	0	0	0	0	0	0	0

Note:

147. Offset related to 0x0200 for blocking access and 0x300 for non blocking access within the global address space.

**Table 205. CTR0 - Register Field Descriptions**

Field	Description
7 LINTRE	LIN trim enable 0 - no trim can be done 1 - trim can be done by setting LINTR bit
6 LINTR	LIN trim bit 0 - default slope 1 - adjust the slope
5 WDCTRE	Watchdog trim enable 0 - no trim can be done 1 - trim can be done by setting WDCTR[2:0] bits
4 CTR0_4	Spare Trim bit 4

**Table 205. CTR0 - Register Field Descriptions (continued)**

Field	Description
3 CTR0_3	Spare Trim bit 3
2-0 WDCTR2...0	Watchdog clock trim (Trim effect to the 100 kHz Watch dog base clock) 000: 0% 001: +5% 010: +10% 011: +15% 100: -20% 101: -15% 110: -10% 111: -5%

#### 4.25.2.2 Trimming Register 1 (CTR1)

**Table 206. Trimming Register 1 (CTR1)**

 Offset<sup>(148)</sup> 0xF1

Access: User read/write

	7	6	5	4	3	2	1	0
R	BGTRE	CTR1_6	BGTRIMUP	BGTRIMDN	IREFTRE	IREFTR2	IREFTR1	IREFTR0
W								
Reset	0	0	0	0	0	0	0	0

Note:

148. Offset related to 0x0200 for blocking access and 0x300 for non blocking access within the global address space.

**Table 207. CTR1 - Register Field Descriptions**

Field	Description
7 BGTRE	Bandgap trim enable 0 - no trim can be done 1 - trim can be done by setting BGTRIMUP and BGTRIMDN bits
6 CTR1_6	Spare Trim Bit
5 BGTRIMUP	Bandgap trim up bit 0 - default slope 1 - increase bandgap slope
4 BGTRIMDN	Bandgap trim down bit 0 - default slope 1 - decrease bandgap slope
3 IREFTRE	Iref trim enable bit 0 - no trim can be done 1 - trim can be done by setting IREFTR[2:0] bits
2-0 IREFTR2...0	Iref trim - This trim is used to adjust the internal zero TC current reference 000: 0% 001: +7.6% 010: +16.43% 011: +26.83% 100: -8.54% 101: -15.75% 110: -21.79% 111: 0%

### 4.25.2.3 Trimming Register 2 (CTR2)

**Table 208. Trimming Register 2 (CTR2)**

Offset <sup>(149)</sup> 0xF2		Access: User read/write							
		7	6	5	4	3	2	1	0
R		0	0	0	SLPBGTRE	SLPBG_LOCK	SLPBGTR2	SLPBGTR1	SLPBGTR0
W									
Reset		0	0	0	0	0	0	0	0

Note:

149. Offset related to 0x0200 for blocking access and 0x300 for non blocking access within the global address space.

**Table 209. CTR2 - Register Field Descriptions**

Field	Description
4 SLPBGTRE	Sleep Bandgap trim enable 0 no trim can be done 1 trim lock can be done by setting SLPBGTR[2:0] bits and SLPBG_LOCK bit
3 (150) SLPBG_LOCK	bg1p25sleep trim lock bit. This bit locks the SLPBGTR2...0 Bit. Once the trim is locked, no other trim values can be loaded into the analog trim registers of CTR2. Asserting a device RESET only clears the contents of the digital trim registers. To reset or change the contents of the analog trim registers, the device must undergo a complete power down and restart.
2-0 SLPBGTR2...0	bg1p25sleep trim - This trim is used to adjust the internal sleep mode 1.25 V bandgap used as a reference for the VDD and VDDx overvoltage detection. 000: -12.2% (default) 001: -8.2% 010: -4.2% 011: 0% 100: +4.2% 101: +8.3% 110: +12.5% 111: -12.2% (default)

Note:

 150. See [MM912F634, Silicon Analog Mask \(M91W\) / Digital Mask \(M33G\) Errata](#).

### 4.25.2.4 Trimming Register 3 (CTR3)

**Table 210. Trimming Register 3 (CTR3)**

Offset <sup>(151)</sup> 0xF3		Access: User read/write							
		7	6	5	4	3	2	1	0
R		OFFCTRE	OFFCTR2	OFFCTR1	OFFCTR0	CTR3_E	CTR3_2	CTR3_1	CTR3_0
W									
Reset		0	0	0	0	0	0	0	0

Note:

151. Offset related to 0x0200 for blocking access and 0x300 for non blocking access within the global address space.

**Table 211. CTR3 - Register Field Descriptions**

Field	Description
7 OFFCTRE	ADC offset compensation voltage trim enable bit 0 - no trim can be done 1 - trim can be done by setting OFFCTR[2:0] bits
6-4 OFFCTR2...0	ADCOFFC trim - This trim is used to adjust the internal ADC offset compensation voltage 000: 0% 001: +7.98% 010: +15.97% 011: +23.95% 100: -23.95% 101: -15.97% 110: -7.98% 111: 0%
3 CTR3_E	Spare Trim enable bit
2 CTR3_2	Spare Trim bit 2
1 CTR3_1	Spare Trim bit 1
0 CTR3_0	Spare Trim bit 0

## 4.26 MM912F634 - MCU Die Overview

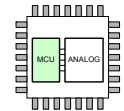

### 4.26.1 Introduction

The MC9S12I32 micro controller implemented in the MM912F634 is the first member of the newly introduced S12S platform, mainly targeted for Intelligent Distributed Control (IDC) applications. The MC9S12I32 device is designed as counter part to an analog die, and is not being offered as a standalone MCU.

The MC9S12I32 die contains a HCS12 Central Processing Unit (CPU), offering 32 kB of Flash memory and 2.0 kB of system SRAM, up to six general purpose I/Os, an on-chip oscillator and clock multiplier, one Serial Peripheral Interface (SPI), an interrupt module, and debug capabilities via the on-chip debug module (DBG) in combination with the Background Debug Mode (BDM) interface. The MC9S12I32 die has no external bus interface, and thus no emulation capability as well as no internal voltage regulator. Additionally there is a die-to-die initiator (D2DI) which represents the communication interface to the companion (analog) die.

#### 4.26.1.1 Features

- 16-Bit S12S CPU
  - Upward compatible with the CPU12 instruction set
    - Note: Five Fuzzy instructions (MEM, WAV, WAVR, REV, REVW) are not supported on this device.
- INT (interrupt module)
  - Supporting nested interrupts
- MMC (memory mapping control and crossbar switch)
- DBG (debug module)
  - Monitoring of the CPU bus with tag-type or force-type breakpoint requests
  - 64 x 20-bit circular trace buffer captures change-of-flow or memory access information
- BDM (background debug mode)
- OSC (oscillator)
  - Full-swing Pierce oscillator option utilizing a 4.0 MHz to 16 MHz crystal or resonator
- CRG (clock and reset generation)
  - 32 kHz trimmable internal reference clock
  - Oscillator clock monitor
  - Internal Digital Controlled Oscillator (DCO), Frequency Locked Loop (FLL) based

- COP module (Computer Operating Properly watchdog)
- RTI module (Real Time Interrupt)
- Memory Options
  - 32 k byte Flash
  - 2.0 k byte RAM
- Flash General Features
  - Erase sector size 512 bytes
  - Automated program and erase algorithm
- Serial Peripheral Interface Module (SPI)
  - Configurable for 8 or 16-bit data size
- Input/Output
  - Up to 6 general-purpose input/output (I/O) pins
  - Hysteresis on all input pins
  - Configurable drive strength on all output pins
- Die 2 Die Initiator (D2DI)
  - Up to 2.0 Mbyte/s data rate
  - Configurable 4-bit or 8-bit wide data path
- 20 MHz maximum CPU bus frequency (16 MHz for MM912F634CV2AP)

#### 4.26.1.2 Modes of Operation

Memory map and bus interface modes:

- Normal operating mode
  - Normal single-chip mode
- Special Operating mode
  - Special single-chip mode with active background debug mode

Low-power modes:

- System stop mode
- System wait mode

**4.26.2 Block Diagrams**

Figure 44 shows a block diagram of the MC9S12I32 device

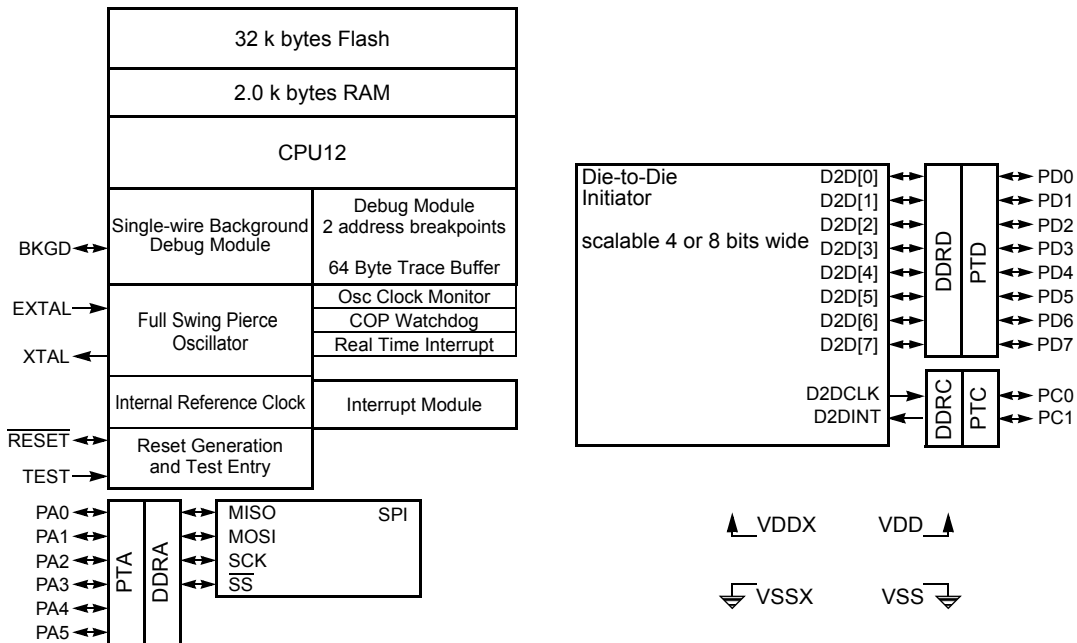

Figure 44. MC9S12I32 Block Diagram

**4.26.3 Device Memory Map**

**4.26.3.1 Address Mapping**

Figure 45 shows S12S CPU & BDM local address translation to the global memory map. It also indicates the location of the internal resources in the memory map.

Table 212. Device Internal Resources

Internal Resource	Bottom Address	Top Address
Registers	0x0_0000	0x0_03FF
IFR (if MMCCTL1.IFRON == 1'b1)	0x0_0400	0x0_047F
Reserved <sup>(152)</sup> (if MMCCTL1.IFRON == 1'b0)		
RAM	0x0_0800	RAM_HIGH = 0x0_07FF plus RAMSIZE <sup>(153)</sup>
FLASH <sup>(154)</sup>	FLASH_LOW = 0x4_0000 minus FLASHSIZE <sup>(155)</sup>	0x3_FFFF

- Note:
- 152. Write access to Reserved has no effect. Read access returns always 0x0000.
  - 153. RAMSIZE is the hexadecimal value of RAM SIZE in bytes.
  - 154. Accessing unimplemented FLASH pages causes an illegal address reset.
  - 155. FLASHSIZE is the hexadecimal value of FLASH SIZE in bytes.

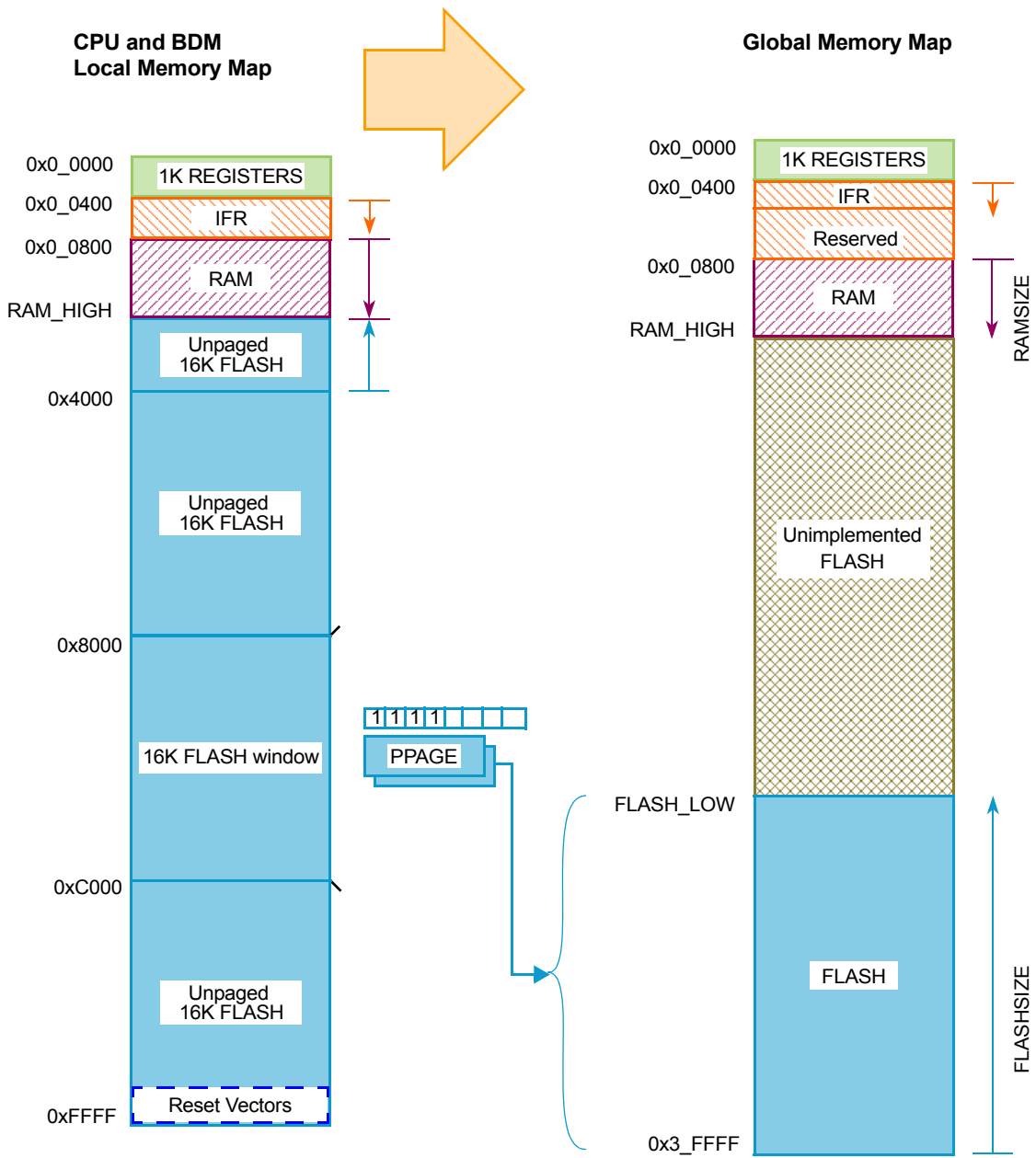

Figure 45. MC9S12132 Global Address Mapping

### 4.26.4 Part ID Assignments

The part ID is located in two 8-bit registers PARTIDH and PARTIDL (addresses 0x001A and 0x001B). The read-only value is a unique part ID for each revision of the chip. Table 213 shows the assigned part ID number and Mask Set number.

**Table 213. Assigned Part ID Numbers**

Device	Mask Set Number	Part ID <sup>(156)</sup>
MC9S12132	0M33G	\$3800
MC9S12132	1M33G	\$3801

Note:

- 156. The coding is as follows:
  - Bit 15-12: Major family identifier
  - Bit 11-8: Minor family identifier
  - Bit 7-4: Major mask set revision number including FAB transfers
  - Bit 3-0: Minor — non full — mask set revision

### 4.26.5 System Clock Description

The clock and reset generator module (CRG) provides the internal clock signals for the core and all peripheral modules. Figure 46 shows the clock connections from the CRG to all modules. Consult the CRG specification for details on clock generation.

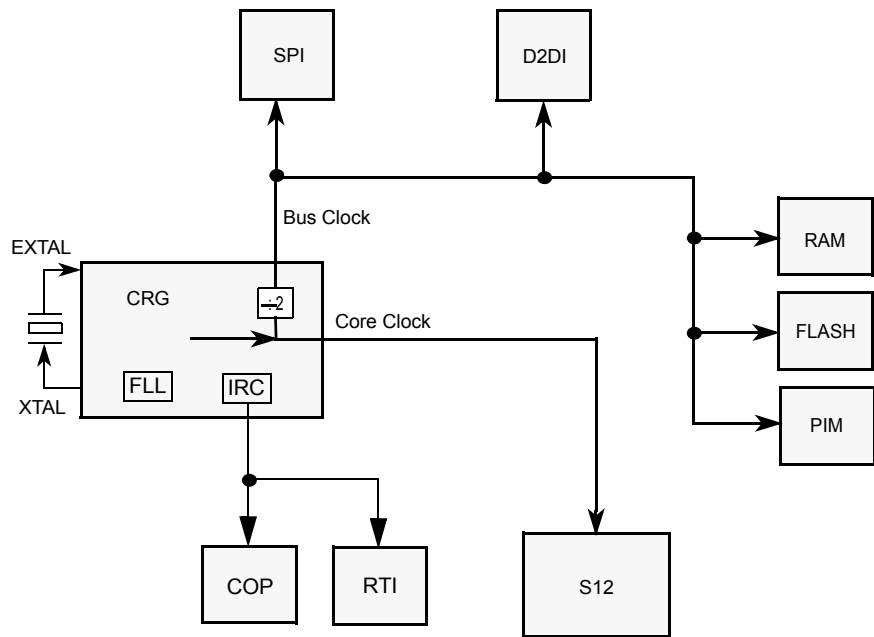

**Figure 46. Clock Connections**

The system clock can be supplied in several ways enabling a range of system operating frequencies to be supported:

- The on-chip frequency locked loop (FLL).
- The oscillator.

The clock generated by the FLL or oscillator provides the main system clock frequencies core clock and bus clock. As shown in Figure 46, these system clocks are used throughout the MCU to drive the core, the memories, and the peripherals. The Flash memory is supplied by the bus clock which is also being used as a time base to derive the program and erase times for the NVM. The MCU includes an on-chip clock monitor connected to the output of the oscillator to ensure the presence of the clock. The clock monitor can be configured to generate a system reset if it is allowed to timeout as a result of no oscillator clock being present.

## 4.26.6 Modes of Operation

The MCU can operate in different chip modes. These are described in [4.26.6.1 Chip Configuration Summary](#). The MCU can operate in different power modes to facilitate power saving when full system performance is not required. These are described in [4.26.6.2 Power Modes](#). Some modules feature a software programmable option to freeze the module status whilst the background debug module is active to facilitate debugging. This is described in [4.26.6.2.4 Freeze Mode](#).

### 4.26.6.1 Chip Configuration Summary

The different modes and the security state of the MCU affect the debug features (enabled or disabled). The operating mode out of reset is determined by the state of the MODC signal during reset (see [Table 214](#)). The MODC bit in the MODE register shows the current operating mode and provides limited mode switching during operation. The state of the MODC signal is registered into this bit on the rising edge of RESET.

**Table 214. Chip Modes**

Chip Modes	MODC
Normal single chip	1
Special single chip	0

#### 4.26.6.1.1 Normal Single-chip Mode

This mode is intended for normal device operation. The opcode from the on-chip memory is being executed after reset (requires the reset vector to be programmed correctly). The processor program is executed from internal memory.

#### 4.26.6.1.2 Special Single-chip Mode

This mode is used for debugging single-chip operation, boot-strapping, or security related operations. The background debug module BDM is active in this mode. The CPU executes a monitor program located in an on-chip ROM. BDM firmware waits for additional serial commands through the BKGD pin.

## 4.26.6.2 Power Modes

The MCU features two main low-power modes. Consult the respective module description for module specific behavior in system stop and system wait mode. An important source of information about the clock system is the Clock and Reset Generator description (CRG).

### 4.26.6.2.1 System Stop Mode

The system stop mode is entered if the CPU executes the STOP instruction. Asserting  $\overline{\text{RESET}}$ , D2DINT, or any other interrupt not masked exits system stop mode. System stop mode can be exited by CPU activity - depending on the configuration of the interrupt request.

### 4.26.6.2.2 Wait Mode

This mode is entered when the CPU executes the WAI instruction. In this mode the CPU does not execute instructions. The internal CPU clock is switched off. All peripherals can be active in system wait mode. For further power reduction the peripherals can individually turn off their local clocks. Asserting  $\overline{\text{RESET}}$ , D2DINT, or any other interrupt not masked ends system wait mode.

### 4.26.6.2.3 Run Mode

Although this is not a low-power mode, unused peripheral modules should be disabled in order to save power.

### 4.26.6.2.4 Freeze Mode

The COP and RTI module provide a software programmable option to freeze the module status when the background debug module is active. This is useful when debugging application software. For detailed description of the behavior of the COP and RTI when the background debug module is active consult the corresponding module descriptions.

## 4.26.7 Security

### 4.26.7.1 MC9S12I32

The MCU security feature allows the protection of the on chip Flash. For a detailed description of the security features refer to the [4.36.6, “Flash Module Security”](#) description.

## 4.26.8 Resets and Interrupts

Consult the S12SCPU manual and the [4.27, “Port Integration Module \(9S12I32PIMV1\)”](#) description for information on exception processing.

### 4.26.8.1 Resets

Resets are explained in detail in the [4.27, “Port Integration Module \(9S12I32PIMV1\)”](#) description.

### 4.26.8.2 Vectors

[Table 215](#) lists all interrupt sources and vectors in the order of priority. The interrupt module ([4.27, “Port Integration Module \(9S12I32PIMV1\)”](#)) provides an interrupt vector base register (IVBR) to relocate the vectors.

**Table 215. Interrupt Vector Locations**

Vector Address <sup>(157)</sup>	Interrupt Source	CCR Mask	Local Enable
\$FFFE	System reset or illegal access reset	None	None
\$FFFC	Oscillator monitor reset	None	CRGCTL0 (CME)
\$FFFA	COP watchdog reset	None	COP rate select
Vector base + \$F8	Unimplemented instruction trap	None	None
Vector base+ \$F6	SWI	None	None
Vector base+ \$F4	D2DI Error Interrupt	X Bit	None
Vector base+ \$F2	D2DI External Error Interrupt	I bit	D2DIE (D2DCTL1)
Vector base+ \$F0	Real time interrupt	I bit	(RTIE)
Vector base + \$D8	SPI	I bit	SPICR1 (SPIE, SPTIE)
Vector base + \$C6	CRG FLL lock	I bit	CRGCTL1(LOCKIE)
Vector base + \$B8	FLASH	I bit	FCNFG (CBEIE, CCIE)
Vector base + \$80	Spurious Interrupt	-	None

Note:

157. 16 bits vector address based

### 4.26.8.3 Effects of Reset

When a reset occurs, MCU registers and control bits are changed to known start-up states. Refer to the respective block descriptions for register reset states.

#### 4.26.8.3.1 I/O Pins

Refer to the [4.27, “Port Integration Module \(9S12I32PIMV1\)”](#) description for reset configurations of all peripheral module ports.

#### 4.26.8.3.2 Memory

The RAM array is not initialized out of reset.

## 4.27 Port Integration Module (9S12I32PIMV1)

### 4.27.1 Introduction

The Port Integration Module (PIM) establishes the interface between the S12I32 peripheral modules SPI and the Die-To-Die Interface module (D2DI) to the I/O pins of the MCU. Depending on the package option the D2DI related pins may or may not be available externally; if used in a dual-die package this interface is internal.

All pins support general purpose I/O functionality if not in use by the peripheral module. The PIM controls the signal prioritization and multiplexing on the shared pins and the pull-down functionality on specific pins.

### 4.27.2 Features

- 6-pin port A associated with the SPI module
- 2-pin port C used as D2DI clock output and D2DI interrupt input
- 8-pin port D used as 8 or 4-bit data I/O for the D2DI interface
- GPIO function shared on all pins
- Pull-down devices on PC1 and PD7-0 if used as D2DI inputs
- Reduced drive capability on port A on per pin basis

The Port Integration Module includes these distinctive registers:

- Data registers for ports A, C, and D, when used as general-purpose I/O
- Data direction registers for ports A, C, and D, when used as general-purpose I/O
- Port input register on port A
- Reduced drive register on port A

A standard port A pin has the following features:

- Input/output selection
- 5.0 V output drive
- 5.0 V digital input

A standard port C and D pin has the following features:

- Input/output selection
- 2.5 V output drive
- 2.5 V digital input

### 4.27.3 Memory Map

Table 216. Memory Map

Register Name		Bit 7	6	5	4	3	2	1	Bit 0
0x0000 PTA	R	0	0	PTA5	PTA4	PTA3	PTA2	PTA1	PTA0
	W								
0x0001 Reserved	R	0	0	0	0	0	0	0	0
	W								
0x0002 DDRA	R	0	0	DDRA5	DDRA4	DDRA3	DDRA2	DDRA1	DDRA0
	W								
0x0003 Reserved	R	0	0	0	0	0	0	0	0
	W								
0x0004 PTC	R	0	0	0	0	0	0	PTC1	PTC0
	W								
0x0005 PTD	R	PTD7	PTD6	PTD5	PTD4	PTD3	PTD2	PTD1	PTD0
	W								

**Table 216. Memory Map (continued)**

Register Name		Bit 7	6	5	4	3	2	1	Bit 0
0x0006 DDRC	R	0	0	0	0	0	0	DDRC1	DDRC0
	W								
0x0007 DDRDR	R	DDRDR7	DDRDR6	DDRDR5	DDRDR4	DDRDR3	DDRDR2	DDRDR1	DDRDR0
	W								
0x0008- 0x0017 Reserved	R	0	0	0	0	0	0	0	0
	W								
0x0120 PTIA	R	0	0	PTIA5	PTIA4	PTIA3	PTIA2	PTIA1	PTIA0
	W								
0x0121 Reserved	R	0	0	0	0	0	0	0	0
	W								
0x0122 RDRA	R	0	0	RDRA5	RDRA4	RDRA3	RDRA2	RDRA1	RDRA0
	W								
0x0123- 0x01FF Reserved	R	0	0	0	0	0	0	0	0
	W								

**4.27.3.1 Port A Data Register (PTA)**

**Table 217. Port A Data Register (PTA)**

Address 0x0000 Access: User read/write<sup>(158)</sup>

	7	6	5	4	3	2	1	0
R	0	0	PTA5	PTA4	PTA3	PTA2	PTA1	PTA0
W								
SPI Function	—	—	—	—	SS	SCK	MOSI	MISO
Reset	0	0	0	0	0	0	0	0

Note:  
158. Read: Anytime.  
Write: Anytime.

**Table 218. Port A Data Register Description**

Field	Description
5 PTA	<b>Port A general purpose input/output data—Data Register</b> If the associated data direction bit of this pin is set to 1, a read returns the value of the port register, otherwise the buffered and synchronized pin input state is read.
4 PTA	<b>Port A general purpose input/output data—Data Register</b> If the associated data direction bit of this pin is set to 1, a read returns the value of the port register, otherwise the buffered and synchronized pin input state is read.
3 PTA	<b>Port A general purpose input/output data—Data Register</b> Port A pin 3 is associated with the $\overline{SS}$ signal of the SPI module. When not used with the alternative function, this pin can be used as general purpose I/O. If the associated data direction bit of this pin is set to 1, a read returns the value of the port register, otherwise the buffered and synchronized pin input state is read.

**Table 218. Port A Data Register Description (continued)**

Field	Description
2 PTA	<b>Port A general purpose input/output data—Data Register</b> Port A pin 2 is associated with the SCK signal of the SPI module. When not used with the alternative function, this pin can be used as general purpose I/O. If the associated data direction bit of this pin is set to 1, a read returns the value of the port register, otherwise the buffered and synchronized pin input state is read.
1 PTA	<b>Port A general purpose input/output data—Data Register</b> Port A pin 1 is associated with the MOSI signal of the SPI module. When not used with the alternative function, this pin can be used as general purpose I/O. If the associated data direction bit of this pin is set to 1, a read returns the value of the port register, otherwise the buffered and synchronized pin input state is read.
0 PTA	<b>Port A general purpose input/output data—Data Register</b> Port A pin 0 is associated with the MISO signal of the SPI module. When not used with the alternative function, this pin can be used as general purpose I/O. If the associated data direction bit of this pin is set to 1, a read returns the value of the port register, otherwise the buffered and synchronized pin input state is read.

#### 4.27.3.2 PIM Reserved Register

**Table 219. PIM Reserved Register**

Address	0x0001							Access: User read <sup>(159)</sup>
	7	6	5	4	3	2	1	0
R	0	0	0	0	0	0	0	0
W								
Reset	0	0	0	0	0	0	0	0

Note:

159. Read: Anytime.  
Write: Unimplemented. Writing to this register has no effect.

#### 4.27.3.3 Port A Data Direction Register (DDRA)

**Table 220. Port A Data Direction Register (DDRA)**

Address	0x0002							Access: User read/write <sup>(160)</sup>
	7	6	5	4	3	2	1	0
R	0	0	DDRA5	DDRA4	DDRA3	DDRA2	DDRA1	DDRA0
W								
Reset	0	0	0	0	0	0	0	0

Note:

160. Read: Anytime.  
Write: Anytime.

**Table 221. DDRA Register Field Descriptions**

Field	Description
5-0 DDRA	<b>Port A Data Direction—</b> This register controls the data direction of pins 5 through 0. The SPI function controls the data direction for the associated pins. In this case the data direction bits do not change. When operating a pin as a general purpose I/O, the associated data direction bit determines whether it is an input or output. 1 Associated pin is configured as output. 0 Associated pin is configured as high-impedance input.

**4.27.3.4 PIM Reserved Register**

**Table 222. PIM Reserved Register**

Address 0x0003 Access: User read<sup>(161)</sup>

	7	6	5	4	3	2	1	0
R	0	0	0	0	0	0	0	0
W								
Reset	0	0	0	0	0	0	0	0

Note:  
 161. Read: Anytime.  
 Write: Unimplemented. Writing to this register has no effect.

**4.27.3.5 Port C Data Register (PTC)**

**Table 223. Port C Data Register (PTC)**

Address 0x0004 Access: User read/write<sup>(162)</sup>

	7	6	5	4	3	2	1	0
R	0	0	0	0	0	0	PTC1	PTC0
W								
D2DI Function	—	—	—	—	—	—	D2DINT	D2DCLK
Reset	0	0	0	0	0	0	0	0

Note:  
 162. Read: Anytime.  
 Write: Anytime.

**Table 224. PTC Register Field Descriptions**

Field	Description
1 PTC	<p><b>Port C general purpose input/output data—Data Register</b>                      Port C pin 1 is associated with the D2DINT signal of the D2DI module.                      When not used with the alternative function, this pin can be used as general purpose I/O.                      If the associated data direction bit of this pin is set to 1, a read returns the value of the port register, otherwise the buffered and synchronized pin input state is read.</p>
0 PTC	<p><b>Port C general purpose input/output data—Data Register</b>                      Port C pin 0 is associated with the D2DCLK signal of the D2DI module.                      When not used with the alternative function, this pin can be used as general purpose I/O.                      If the associated data direction bit of this pin is set to 1, a read returns the value of the port register, otherwise the buffered and synchronized pin input state is read.</p>

### 4.27.3.6 Port D Data Register (PTD)

**Table 225. Port D Data Register (PTD)**

Address		0x0005						Access: User read/write <sup>(163)</sup>	
		7	6	5	4	3	2	1	0
R		PTD7	PTD6	PTD5	PTD4	PTD3	PTD2	PTD1	PTD0
W									
D2DI Function		D2DDAT7	D2DDAT6	D2DDAT5	D2DDAT4	D2DDAT3	D2DDAT2	D2DDAT1	D2DDAT0
Reset		0	0	0	0	0	0	0	0

Note:

 163. Read: Anytime.  
 Write: Anytime.

**Table 226. PTD Register Field Descriptions**

Field	Description
7-0 PTD	<b>Port D general purpose input/output data—Data Register</b> Port D pins 7 through 0 are associated with the D2DI data signals of the D2DI module if enabled in 8-bit mode. Port D pins 3 through 0 are associated with the D2DI data signals of the D2DI module if enabled in 4-bit mode. When not used with the alternative function, these pins can be used as general purpose I/O. If the associated data direction bit of this pin is set to 1, a read returns the value of the port register, otherwise the buffered and synchronized pin input state is read.

### 4.27.3.7 Port C Data Direction Register (DDRC)

**Table 227. Port C Data Direction Register (DDRC)**

Address		0x0006						Access: User read/write <sup>(164)</sup>	
		7	6	5	4	3	2	1	0
R		0	0	0	0	0	0	DDRC1	DDRC0
W									
Reset		0	0	0	0	0	0	0	0

Note:

 164. Read: Anytime.  
 Write: Anytime.

**Table 228. DDRC Register Field Descriptions**

Field	Description
1-0 DDRC	<b>Port C Data Direction—</b> This register controls the data direction of pins 1 and 0. The D2DI function controls the data direction for the associated pins. In this case the data direction bits do not change. When operating a pin as a general purpose I/O, the associated data direction bit determines whether it is an input or output. 1 Associated pin is configured as output. 0 Associated pin is configured as high-impedance input.

### 4.27.3.8 Port D Data Direction Register (DDRD)

**Table 229. Port D Data Direction Register (DDRD)**

Address 0x0007 Access: User read/write<sup>(165)</sup>

	7	6	5	4	3	2	1	0
R	DDRD7	DDRD6	DDRD5	DDRD4	DDRD3	DDRD2	DDRD1	DDRD0
W								
Reset	0	0	0	0	0	0	0	0

Note:

165. Read: Anytime.  
Write: Anytime.

**Table 230. DDRD Register Field Descriptions**

Field	Description
7-0 DDRD	<b>Port D Data Direction—</b> This register controls the data direction of pins 7 through 0. The D2DI function controls the data direction for the associated pins. In this case the data direction bits do not change. When operating a pin as a general purpose I/O, the associated data direction bit determines whether it is an input or output. 1 Associated pin is configured as output. 0 Associated pin is configured as high-impedance input.

### 4.27.3.9 PIM Reserved Registers

**Table 231. PIM Reserved Registers**

Address 0x0008-0x0019 Access: User read<sup>(166)</sup>

	7	6	5	4	3	2	1	0
R	0	0	0	0	0	0	0	0
W								
Reset	0	0	0	0	0	0	0	0

Note:

166. Read: Anytime.  
Write: Unimplemented. Writing to these registers has no effect.

### 4.27.3.10 Port A Input Register (PTIA)

**Table 232. Port A Input Register (PTIA)**

Address 0x0120 Access: User read<sup>(167)</sup>

	7	6	5	4	3	2	1	0
R	0	0	PTIA5	PTIA4	PTIA3	PTIA2	PTIA1	PTIA0
W								
Reset <sup>(168)</sup>	u	u	u	u	u	u	u	u

Note:

167. Read: Anytime.  
Write: Unimplemented. Writing to this register has no effect.  
168. u = Unaffected by reset

**Table 233. PTIA Register Field Descriptions**

Field	Description
5-0 PTIA	<b>Port A input data</b> — This register always reads back the buffered and synchronized state of the associated pins. This can also be used to detect overload or short circuit conditions on output pins.

**4.27.3.11 PIM Reserved Register**
**Table 234. PIM Reserved Register**

Address 0x0121

 Access: User read<sup>(169)</sup>

	7	6	5	4	3	2	1	0
R	0	0	0	0	0	0	0	0
W								
Reset	0	0	0	0	0	0	0	0

Note:

169. Read: Anytime.

Write: Unimplemented. Writing to this register has no effect.

**4.27.3.12 Port A Reduced Drive Register (RDRA)**
**Table 235. Port A Reduced Drive Register (RDRA)**

Address 0x0122

 Access: User read/write<sup>(170)</sup>

	7	6	5	4	3	2	1	0
R	0	0	RDRA5	RDRA4	RDRA3	RDRA2	RDRA1	RDRA0
W								
Reset	0	0	0	0	0	0	0	0

Note:

170. Read: Anytime. Write: Anytime.

**Table 236. RDRA Register Field Descriptions**

Field	Description
5-0 RDRA	<b>Port A reduced drive—Select reduced drive for outputs</b> This register configures the drive strength of output pins as either full or reduced. If a pin is used as input this bit has no effect. 1 Reduced drive selected (1/6 of the full drive strength). 0 Full drive strength enabled.

### 4.27.3.13 PIM Reserved Registers

**Table 237. PIM Reserved Register**

Address 0x0123-0x017F		Access: User read <sup>(171)</sup>						
	7	6	5	4	3	2	1	0
R	0	0	0	0	0	0	0	0
W								
Reset	0	0	0	0	0	0	0	0

Note:

- 171. Read: Anytime.  
Write: Unimplemented. Writing to these registers has no effect.

## 4.27.4 Functional Description

### 4.27.4.1 General

Each pin can act as a general purpose I/O. In addition, each pin (except PTA5-4) can act as an input or output of a peripheral module.

### 4.27.4.2 Registers

#### 4.27.4.2.1 Data register (PTx)

This register holds the value driven out to the pin, if the pin is used as a general purpose I/O. Writing to this register only has an effect on the pin, if the pin is used as a general purpose output. When reading this address, the buffered and synchronized state of the pin is returned, if the associated data direction register bit is set to “0”. If the data direction register bits are set to logic level “1”, the contents of the data register is returned. This is independent of any other configuration (Figure 47).

#### 4.27.4.2.2 Data direction register (DDRx)

This register defines whether the pin is used as an input or an output. If a peripheral module controls the pin the contents of the data direction register is ignored (Figure 47).

#### 4.27.4.2.3 Input register (PTIx)

This is a read-only register and always returns the buffered and synchronized state of the pin (Figure 47).

#### 4.27.4.2.4 Reduced drive register (RDRx)

If the pin is used as an output this register allows the configuration of the drive strength.

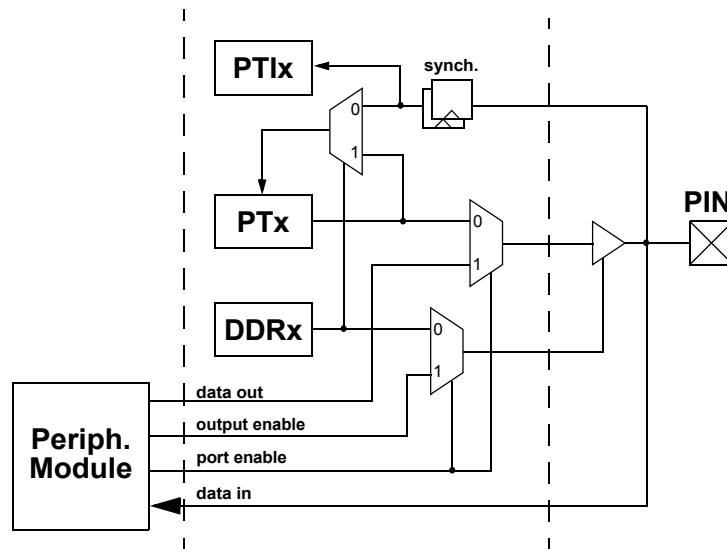

Figure 47. Illustration of I/O Pin Functionality

### 4.27.4.3 Ports

#### 4.27.4.3.1 Port A

This port is associated with the SPI. Port A pins PA5-0 can be used for general-purpose I/O and PA3-0, also with the SPI subsystem.

#### 4.27.4.3.2 Port C

This port is associated with the D2DI interface. Port C pins PC1-0 can be used either for general-purpose I/O, or as the D2DI interrupt input and D2DI clock output, respectively. A pull-down device is enabled on pin PC1 if used as D2DI input. The D2DI interrupt input is synchronized and has an asynchronous bypass in STOP mode to allow the generation of a wake-up interrupt.

#### 4.27.4.3.3 Port D

This port is exclusively associated with the D2DI interface and not available externally. Port D pins PD7-0 can be used either for general-purpose I/O or with the D2DI data I/O. If the D2DI is enabled in 4-bit mode, pins PD7-4 can be used with general purpose pin functionality. Pull-down devices are enabled on all pins if used as D2DI inputs.

### 4.27.5 Initialization Information

#### 4.27.5.1 Port Data and Data Direction Register writes

It is not recommended to write PTx and DDRx in a word access. When changing the register pins from inputs to outputs, the data may have extra transitions during the write access. Initialize the port data register before enabling the outputs.

## 4.28 Memory Mapping Control (S12SMCV1)

### 4.28.1 Introduction

This section describes the functionality of the module mapping control (MMC) sub-block of the S12S platform. The block diagram of the MMC is shown in [Figure 48](#).

The MMC module controls the multi-master priority accesses (BDM and CPU), the selection of internal resources. Internal buses, including internal memories and peripherals, are controlled in this module. The local address space for each master is translated to a global memory space using the PPAGE register.

### 4.28.1.1 Terminology

**Table 238. Acronyms and Abbreviations**

Logic level "1"	Voltage corresponding to the Boolean true state
Logic level "0"	Voltage corresponding to the Boolean false state
0x	Represents hexadecimal number
x	Represents logic level 'don't care'
byte	8-bit data
word	16-bit data
local address	based on the 64 Kilobytes Memory Space (16-bit address)
global address	based on the 256 Kilobytes Memory Space (18-bit address)
Aligned address	Address on even boundary
Mis-aligned address	Address on odd boundary
Bus Clock	System Clock. Refer to CRG Block Guide.
single-chip modes	Normal Single-chip mode Special Single-chip mode
normal modes	Normal Single-chip mode
special modes	Special Single-chip mode
NS	Normal Single-chip mode
SS	Special Single-chip mode
Unimplemented areas	Areas which are accessible by the PPAGE, and not implemented
MCU	Micro-Controller Unit
NVM	Non-volatile Memory; Flash EEPROM or ROM
IFR	NVM Information Row. Refer to FTSR Block Guide

### 4.28.1.2 Features

The main features of this block are:

- Paging capability to support a global 256 Kilobytes memory address space
- Bus arbitration between the masters CPU, BDM to different resources (internal and peripherals). Note: resources are also called targets.
- MCU operation mode control
- MCU security control
- Separate memory map schemes for each master CPU, BDM
- Generation of system reset when CPU accesses an unimplemented address (i.e., an address which does not belong to any of the on-chip modules) in single-chip modes

### 4.28.1.3 S12S Memory Mapping

The S12S architecture implements one memory mapping scheme including:

- A (CPU or BDM) 64 kByte local map, defined using specific resource page (PPAGE) register and the default instruction set. The 64 Kilobytes visible at any instant can be considered as the local map accessed by the 16-bit (CPU or BDM) address.

#### 4.28.1.4 Modes of Operation

This subsection lists and briefly describes all operating modes supported by the MMC.

##### 4.28.1.4.1 Power Saving Modes

- Run mode  
MMC is functional during normal run mode.
- Wait mode  
MMC is functional during wait mode.
- Stop mode  
MMC is inactive during stop mode.

##### 4.28.1.4.2 Functional Modes

- Single chip modes  
In normal and special single chip mode the internal memory is used.

#### 4.28.1.5 Block Diagram

Figure 48 shows a block diagram of the MMC.

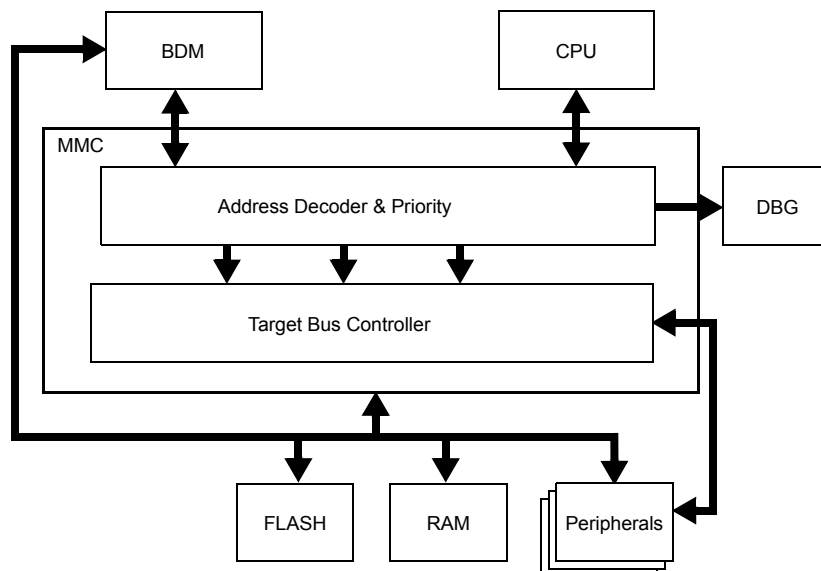

Figure 48. MMC Block Diagram External Signal Description

The user is advised to refer to the SoC Guide for port configuration and location of external bus signals. Some pins may not be bonded out in all implementations. Table 239 outlines the pin names and functions. It also provides a brief description of their operation.

Table 239. External Input Signals Associated with the MMC

Signal	I/O	Description	Availability
MODC	I	Mode input	Latched after $\overline{\text{RESET}}$ (active low)

#### 4.28.2 Memory Map and Registers

##### 4.28.2.1 Module Memory Map

A summary of the registers associated with the MMC block is shown in Figure 240. Detailed descriptions of the registers and bits are given in the following subsections.

**Table 240. MMC Register Summary**

Address	Register Name		Bit 7	6	5	4	3	2	1	Bit 0
0x0030	PPAGE	R	1	1	1	1	PIX3	PIX2	PIX1	PIX0
		W								
0x0031	DIRECT	R	DP15	DP14	DP13	DP12	DP11	DP10	DP9	DP8
		W								
0x0032	MODE	R	MODC	0	0	0	0	0	0	0
		W								
0x0033	MMCCTL1	R	0	0	0	0	0	0	0	IFRON
		W								

**4.28.2.2 Register Descriptions**

**4.28.2.2.1 Program Page Index Register (PPAGE)**

**NOTE**

Writes to this register using the special access of the CALL and RTC instructions are complete before the end of the instruction execution.

**Table 241. Program Page Index Register (PPAGE)**

Address: 0x0030

	7	6	5	4	3	2	1	0
R	1	1	1	1	PIX3	PIX2	PIX1	PIX0
W								
Reset	1	1	1	1	1	1	1	0

Read: Anytime  
Write: Anytime

These four index bits are used to page 16 kByte blocks into the Flash page window located in the local (CPU or BDM) memory map from address 0x8000 to address 0xBFFF (see [Figure 49](#)). This supports accessing up to 256 Kilobytes of Flash (in the Global map) within the 64 kByte Local map. The PPAGE index register is effectively used to construct paged Flash addresses in the Local map format. The CPU has special access to read and write this register directly, during execution of CALL and RTC instructions.

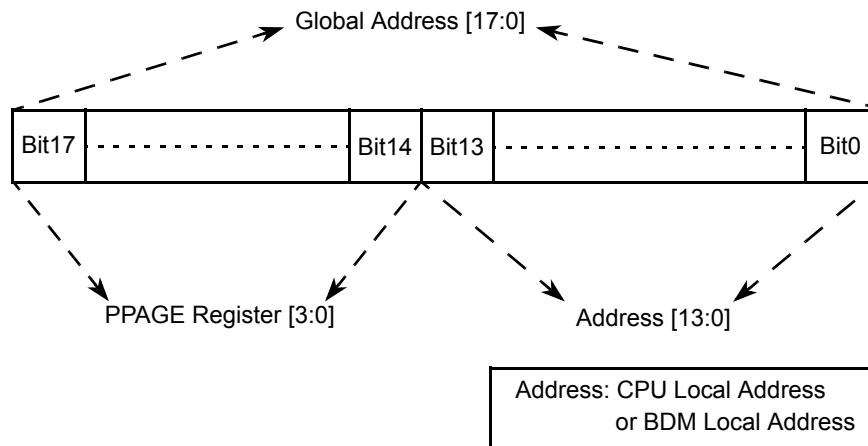

Figure 49. PPAGE Address Mapping

Table 242. PPAGE Field Descriptions

Field	Description
3–0 PIX[3:0]	<b>Program Page Index Bits 3–0</b> — These page index bits are used to select which of the 256 FLASH or ROM array pages is to be accessed in the Program Page Window.

The fixed 16 k page from 0x0000 to 0x3FFF is the page number 0xFC. Parts of this page are covered by Register and RAM space. See SoC Guide for details. The fixed 16 k page from 0x4000–0x7FFF is the page number 0xFD. The reset value of 0xFE ensures there is linear Flash space available between addresses 0x0000 and 0xFFFF out of reset. The fixed 16 k page from 0xC000–0xFFFF is the page number 0xFF.

4.28.2.2.2 Direct Page Register (DIRECT)

Table 243. Direct Register (DIRECT)

Address: 0x0031

	7	6	5	4	3	2	1	0
R	DP15	DP14	DP13	DP12	DP11	DP10	DP9	DP8
W								
Reset	0	0	0	0	0	0	0	0

Read: Anytime

Write: anytime in special modes, one time only in other modes.

This register determines the position of the 256 Byte direct page within the memory map. It is valid for both global and local mapping scheme.

Table 244. DIRECT Field Descriptions

Field	Description
7–0 DP[15:8]	<b>Direct Page Index Bits 15–8</b> — These bits are used by the CPU when performing accesses using the direct addressing mode. The bits from this register form bits [15:8] of the address (see Figure 50).

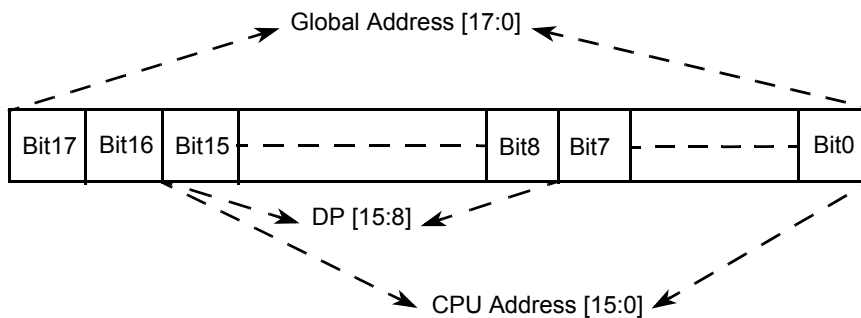

**Figure 50. Direct Address Mapping**

**Example 1. This Example Demonstrates Usage of the Direct Addressing Mode**

```

MOVb    #0x80,DIRECT    ;Set DIRECT register to 0x80. Write once only.
                        ;Global data accesses to the range 0xXX_80XX can be direct.
                        ;Logical data accesses to the range 0x80XX are direct.

LDY     <00             ;Load the Y index register from 0x8000 (direct access).
                        ;< operator forces direct access on some assemblers but in
                        ;many cases assemblers are "direct page aware" and can
                        ;automatically select direct mode.
    
```

**4.28.2.2.3 Mode Register (MODE)**

**Table 245. Mode Register (MODE)**

Address: 0x0032

	7	6	5	4	3	2	1	0
R	MODC	0	0	0	0	0	0	0
W								
Reset	MODC <sup>(172)</sup>	0	0	0	0	0	0	0

Note:  
172. External signal (see Table 239).

Read: Anytime.  
Write: Only if a transition is allowed (see Figure 51).

The MODC bit of the MODE register is used to establish the MCU operating mode.

**Table 246. MODE Field Descriptions**

Field	Description
7 MODC	<p><b>Mode Select Bit</b> — This bit controls the <u>current</u> operating mode during RESET high (inactive). The external mode pin MODC determines the operating mode during RESET low (active). The state of the pin is registered into the respective register bit after the RESET signal goes inactive (see Figure 51).</p> <p>Write restrictions exist to disallow transitions between certain modes. Figure 51 illustrates all allowed mode changes. Attempting non authorized transitions do not change the MODE bit, but it blocks further writes to the register bit except in special modes.</p> <p>Changes of operating modes are not allowed when the device is secured, but it blocks further writes to the register bit except in special modes.</p>

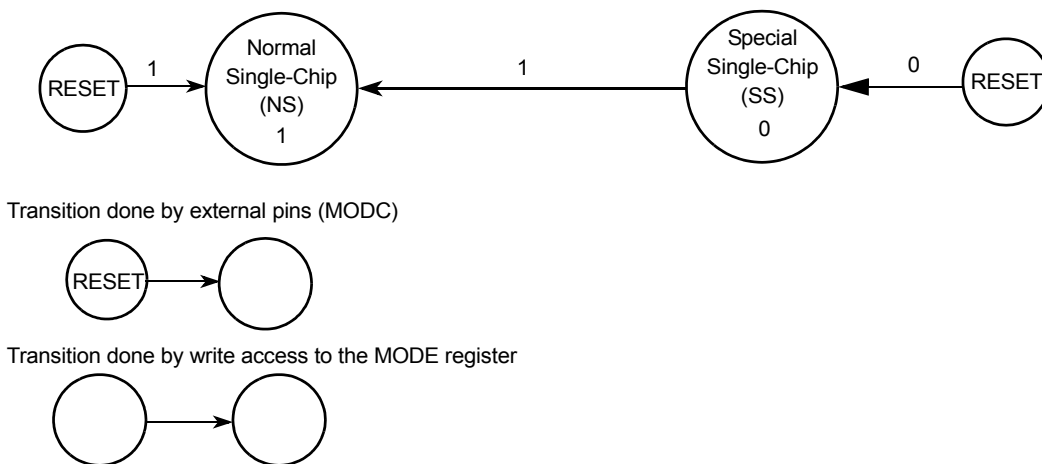

Figure 51. Mode Transition Diagram when the MCU is Unsecured

4.28.2.2.4 MMC Control Register (MMCCTL1)

Figure 52. MMC Control Register (MMCCTL1)

Address: 0x0033

	7	6	5	4	3	2	1	0
R	0	0	0	0	0	0	0	IFRON
W								
Reset	0	0	0	0	0	0	0	0

Read: Anytime.  
Write: Anytime.

The IFRON bit of the MMCCTL1 register is used to make program IFR sector visible in the memory map.

Table 247. MODE Field Descriptions

Field	Description
0 IFRON	<p>Program IFR visible in the memory map Write: Anytime This bit is used to make the IFR sector of the Program Flash visible in the global memory map.</p> <p>0 Not visible in the global memory map. 1 Visible in the global memory map in the range (See Figure 45): [0x0_0400 - 0x0_047F]: IFR contents</p>

4.28.3 Functional Description

The MMC block performs several basic functions of the S12S sub-system operation: MCU operation modes, priority control, address mapping, select signal generation, and access limitations for the system. Each aspect is described in the following subsections.

4.28.3.1 MCU Operating Mode

- Normal single-chip mode  
There is no external bus in this mode. The MCU program is executed from the internal memory and no external accesses are allowed.
- Special single-chip mode  
This mode is generally used for debugging single-chip operation, boot-strapping or security related operations. The active background debug mode is in control of the CPU code execution and the BDM firmware is waiting for serial commands sent through the BKGD pin. There is no external bus in this mode.

## 4.28.3.2 Memory Map Scheme

### 4.28.3.2.1 CPU and BDM Memory Map Scheme

The BDM firmware lookup tables and BDM register memory locations share addresses with other modules. However, they are not visible in the memory map during user's code execution. The BDM memory resources are enabled only during the READ\_BD and WRITE\_BD access cycles to distinguish between accesses to the BDM memory area and accesses to the other modules. (Refer to BDM Block Guide for further details).

When the MCU enters active BDM mode, the BDM firmware lookup tables and the BDM registers become visible in the local memory map in the range 0xFF00-0xFFFF (global address 0x3\_FF00 - 0x3\_FFFF) and the CPU begins execution of firmware commands or the BDM begins execution of hardware commands. The resources which share memory space with the BDM module are not be visible in the memory map during active BDM mode.

Note that after the MCU enters active BDM mode the BDM firmware lookup tables and the BDM registers are also visible between addresses 0xBF00 and 0xBFFF if the PPAGE register contains value of 0xFF.

#### 4.28.3.2.2 Expansion of the Local Address Map

##### 4.28.3.2.2.1 Expansion of the CPU Local Address Map

The program page index register in MMC allows accessing up to 256 kbyte of FLASH or ROM in the global memory map by using the four page index bits to page 16x16 kbyte blocks into the program page window located from address 0x8000 to address 0xBFFF in the local CPU memory map.

The page value for the program page window is stored in the PPAGE register. The value of the PPAGE register can be read or written by normal memory accesses as well as by the CALL and RTC instructions (see [Section 4.28.4.1, "CALL and RTC Instructions"](#)). Control registers, vector space and parts of the on-chip memories are located in unpagged portions of the 64 kilobyte local CPU address space.

The starting address of an interrupt service routine must be located in unpagged memory unless the user is certain the PPAGE register is set to the appropriate value when the service routine is called. However an interrupt service routine can call other routines in pagged memory. The upper 16 kilobyte block of the local CPU memory space (0xC000–0xFFFF) is unpagged. It is recommended all reset and interrupt vectors point to locations in this area or to the other unmapped pages sections of the local CPU memory map.

##### 4.28.3.2.2.2 Expansion of the BDM Local Address Map

PPAGE and BDMPPR register is also used for the expansion of the BDM local address to the global address. These registers can be read and written by the BDM. The BDM expansion scheme is the same as the CPU expansion scheme. The four BDMPPR Program Page index bits allow access to the full 256 kbyte address map which can be accessed with 17 address bits.

The BDM program page index register (BDMPPR) is used only when the feature is enabled in BDM and, in the case the CPU is executing a firmware command which uses CPU instructions, or by a BDM hardware commands. See the BDM Block Guide for further details. (see [Figure 53](#)).

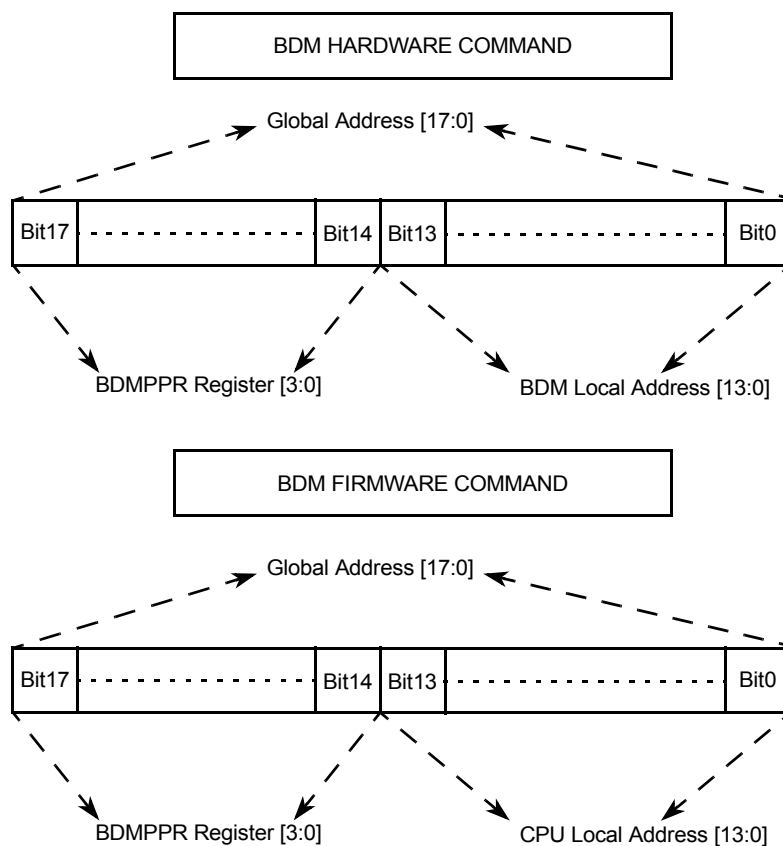
**Figure 53. BDMPPR Address Mapping**

#### 4.28.3.2.3 Implemented Memory Map

The global memory spaces reserved for the internal resources (RAM and FLASH) are not determined by the MMC module. Size of the individual internal resources are however fixed in the design of the device cannot be changed by the user. Refer to the Device User Guide for further details. [Figure 45](#) and [Table 248](#) show the memory spaces occupied by the on-chip resources. Note that the memory spaces have fixed top addresses.

**Table 248. Global Implemented Memory Space**

Internal Resource	Bottom Address	Top Address
Registers	0x0_0000	0x0_03FF
IFR (if MMCCTL1.IFRON == 1'b1)	0x0_0400	0x0_047F
Unimplemented (if MMCCTL1.IFRON == 1'b0)		
Unimplemented	0x0_0480	0x0_07FF
RAM	0x0_0800	RAM_HIGH = 0x0_07FF plus RAMSIZE <sup>(173)</sup>
FLASH	FLASH_LOW = 0x4_0000 minus FLASHSIZE <sup>(174)</sup>	0x3_FFFF

Note:

173. RAMSIZE is the hexadecimal value of RAM SIZE in bytes.

174. FLASHSIZE is the hexadecimal value of FLASH SIZE in bytes.

In single-chip modes accesses by the CPU (except for firmware commands) to any of the unimplemented areas (see [Figure 45](#)) results in an illegal access reset (system reset). BDM accesses to the unimplemented areas are allowed but the data is undefined. No misaligned word access from the BDM module occurs; these accesses are blocked in the BDM module (Refer to BDM Block Guide).

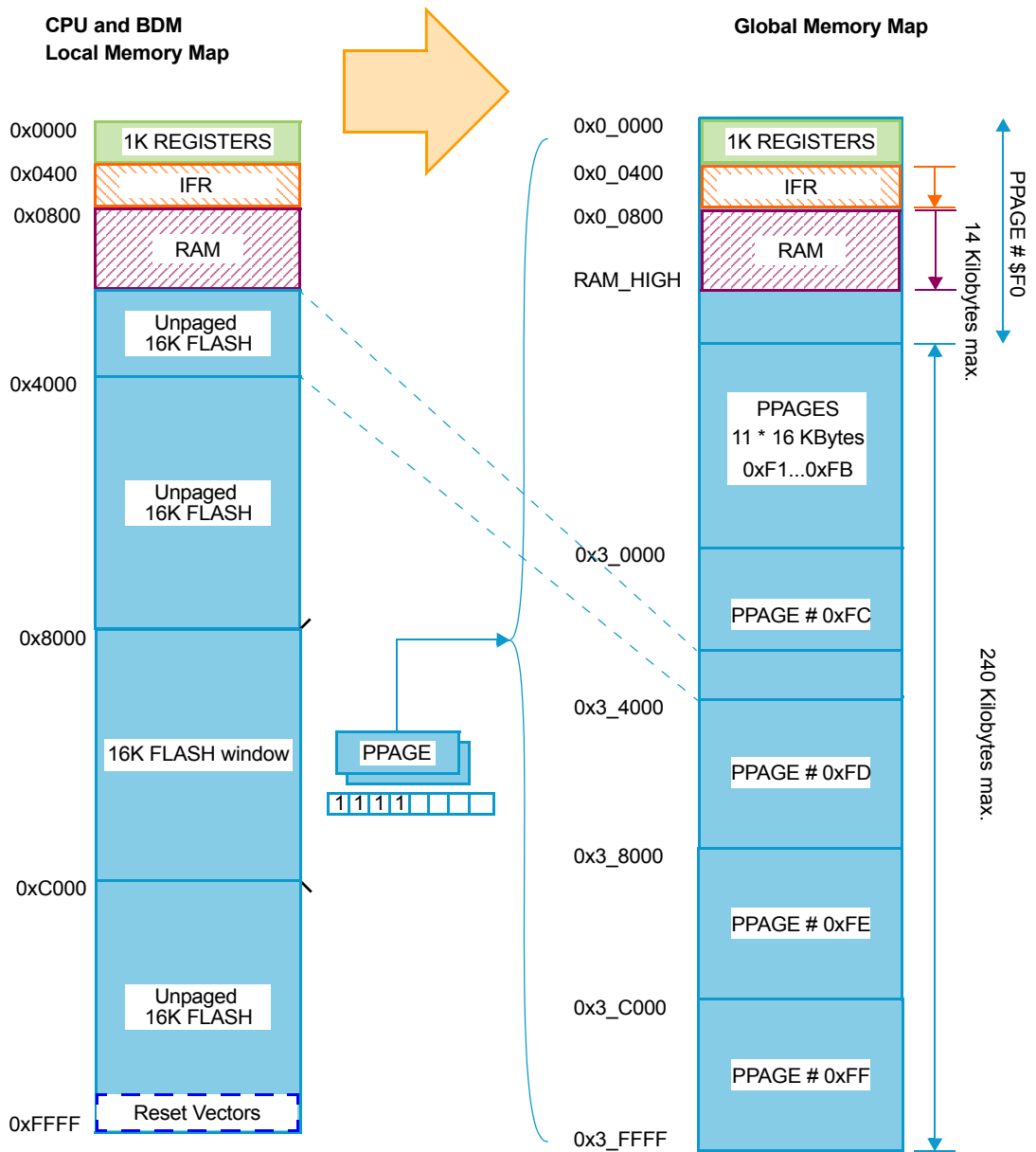

Figure 54. Local to Global Address Mapping

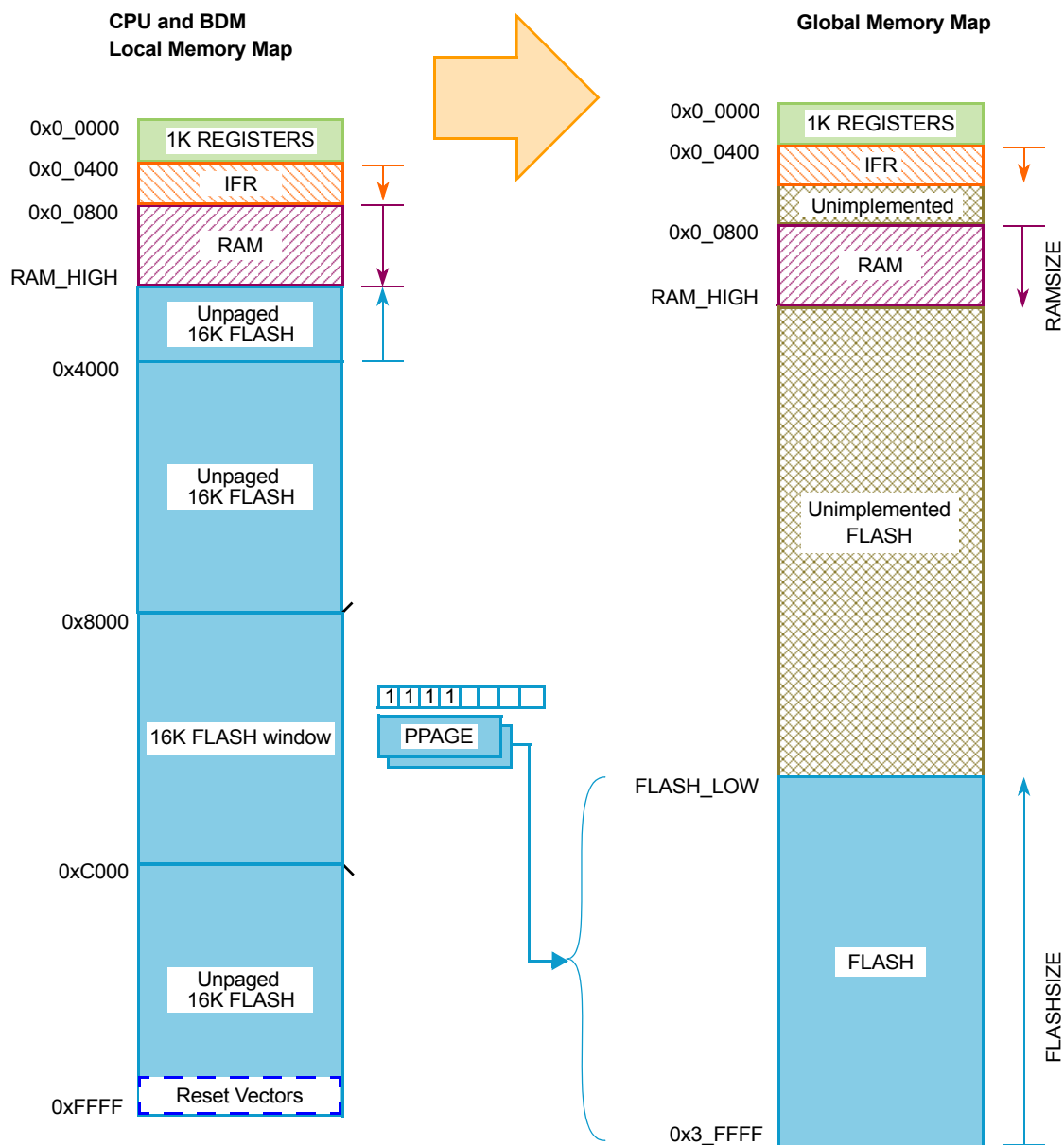

Figure 55. Implemented Global Address Mapping

### 4.28.3.3 Chip Bus Control

The MMC controls the address buses and the data buses interfacing the S12S masters (CPU, BDM) with the rest of the system (master buses). In addition the MMC handles all CPU read data bus swapping operations. All internal resources are connected to specific target buses (see Figure 56).

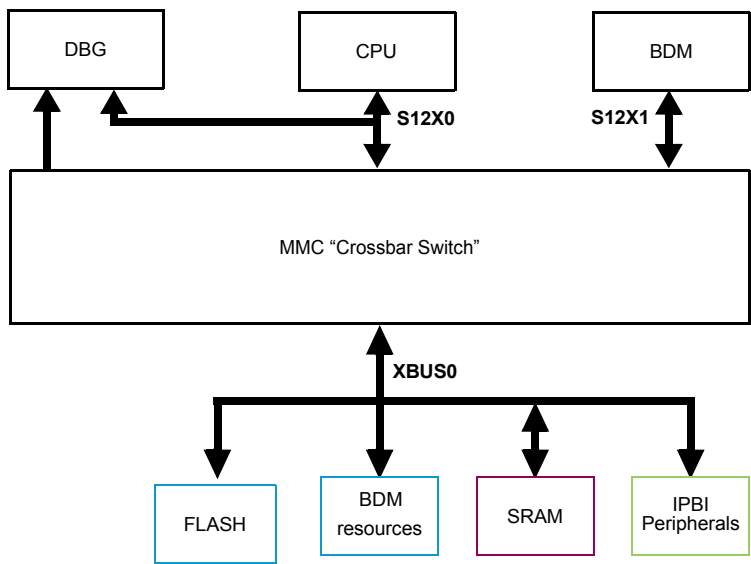

Figure 56. S12S Platform

**4.28.3.3.1 Master Bus Prioritization Regarding Access Conflicts on Target Buses**

The arbitration scheme allows only one master to be connected to a target at any given time. The following rules apply when prioritizing accesses from different masters to the same target bus:

- CPU always has priority over BDM.
- BDM has priority over CPU when its access is stalled for more than 128 cycles. In the later case the CPU is stalled after finishing the current operation and the BDM gains access to the bus.

**4.28.3.4 Interrupts**

The MMC does not generate any interrupts

**4.28.4 Initialization/Application Information**

**4.28.4.1 CALL and RTC Instructions**

CALL and RTC instructions are not interruptable CPU instructions which automate page switching in the program page window. The CALL instruction is similar to the JSR instruction, but the subroutine which is called can be located anywhere in the local address space or in any Flash or ROM page visible through the program page window. The CALL instruction calculates and stacks a return address, stacks the current PPAGE value and writes a new instruction-supplied value to the PPAGE register. The PPAGE value controls which of the 256 possible pages is visible through the 16 kbyte program page window in the 64 kbyte local CPU memory map. Execution then begins at the address of the called subroutine.

During the execution of the CALL instruction, the CPU performs the following steps:

1. Writes the current PPAGE value into an internal temporary register and writes the new instruction-supplied PPAGE value into the PPAGE register
2. Calculates the address of the next instruction after the CALL instruction (the return address) and pushes this 16-bit value onto the stack
3. Pushes the temporarily stored PPAGE value onto the stack
4. Calculates the effective address of the subroutine, refills the queue and begins execution at the new address

This sequence is not interruptable. There is no need to inhibit interrupts during the CALL instruction execution. A CALL instruction can be performed from any address to any other address in the local CPU memory space.

The PPAGE value supplied by the instruction is part of the effective address of the CPU. For all addressing mode variations (except indexed-indirect modes) the new page value is provided by an immediate operand in the instruction. In indexed-indirect variations of the CALL instruction a pointer specifies memory locations where the new page value and the address of the called subroutine are stored. Using indirect addressing for both the new page value and the address within the page allows usage of values calculated at run time rather than immediate values which must be known at the time of assembly.

The RTC instruction terminates subroutines invoked by a CALL instruction. The RTC instruction unstacks the PPAGE value and the return address and refills the queue. Execution resumes with the next instruction after the CALL instruction. During the execution of an RTC instruction the CPU performs the following steps:

1. Pulls the previously stored PPAGE value from the stack
2. Pulls the 16-bit return address from the stack and loads it into the PC
3. Writes the PPAGE value into the PPAGE register
4. Refills the queue and resumes execution at the return address

This sequence is uninterruptable. The RTC can be executed from anywhere in the local CPU memory space.

The CALL and RTC instructions behave like JSR and RTS instruction, they however require more execution cycles. Usage of JSR/RTS instructions is therefore recommended when possible and CALL/RTC instructions should only be used when needed. The JSR and RTS instructions can be used to access subroutines already present in the local CPU memory map (i.e. in the same page in the program memory page window for example). However calling a function located in a different page requires usage of the CALL instruction. The function must be terminated by the RTC instruction. Because the RTC instruction restores contents of the PPAGE register from the stack, functions terminated with the RTC instruction must be called using the CALL instruction even when the correct page is already present in the memory map. This is to make sure the correct PPAGE value is present on stack at the time of the RTC instruction execution.

## 4.29 Interrupt Module (S12SINTV1)

### 4.29.1 Introduction

The 9S12I32PIMV1 module decodes the priority of all system exception requests and provides the applicable vector for processing the exception to the CPU. The 9S12I32PIMV1 module supports:

- I bit and X bit maskable interrupt requests
- A non-maskable unimplemented opcode trap
- A non-maskable software interrupt (SWI) or background debug mode request
- Three system reset vector requests
- A spurious interrupt vector

Each of the I bit maskable interrupt requests is assigned to a fixed priority level.

#### 4.29.1.1 Glossary

CCR — Condition Code Register (in the CPU)  
 ISR — Interrupt Service Routine  
 MCU — Micro-controller Unit

#### 4.29.1.2 Features

- Interrupt vector base register (IVBR)
- One spurious interrupt vector (at address vector base + 0x0080). The vector base is a 16-bit address which is accumulated from the contents of the interrupt vector base register (IVBR, used as upper byte) and 0x00 (used as lower byte).
- 2–58 I bit maskable interrupt vector requests (at addresses vector base + 0x0082–0x00F2).
- I bit maskable interrupts can be nested.
- One X bit maskable interrupt vector request (at address vector base + 0x00F4).
- One non-maskable software interrupt request (SWI) or background debug mode vector request (at address vector base + 0x00F6).
- One non-maskable unimplemented opcode trap (TRAP) vector (at address vector base + 0x00F8).
- Three system reset vectors (at addresses 0xFFFFA–0xFFFFE).
- Determines the highest priority interrupt vector requests, drives the vector to the bus on CPU request
- Wakes up the system from stop or wait mode when an appropriate interrupt request occurs.

**4.29.1.3 Modes of Operation**

- Run mode  
This is the basic mode of operation.
- Wait mode  
In wait mode, the clock to the 9S12I32PIMV1 module is disabled. The 9S12I32PIMV1 module is however capable of waking up the CPU from wait mode if an interrupt occurs. Refer to [Section 4.29.5.3, "Wake-up from Stop or Wait Mode"](#) for details.
- Stop mode  
In stop mode, the clock to the 9S12I32PIMV1 module is disabled. The 9S12I32PIMV1 module is however capable of waking up the CPU from stop mode if an interrupt occurs. Refer to [Section 4.29.5.3, "Wake-up from Stop or Wait Mode"](#) for details.
- Freeze mode (BDM active)  
In freeze mode (BDM active), the interrupt vector base register is overridden internally. Refer to [Section 4.29.3.1.1, "Interrupt Vector Base Register \(IVBR\)"](#) for details.

**4.29.1.4 Block Diagram**

Figure 57 shows a block diagram of the 9S12I32PIMV1 module.

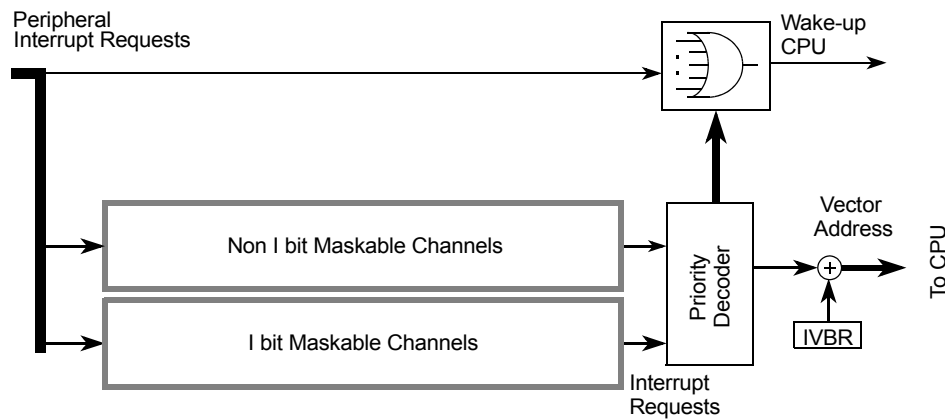

**Figure 57. 9S12I32PIMV1 Block Diagram**

**4.29.2 External Signal Description**

The 9S12I32PIMV1 module has no external signals.

**4.29.3 Memory Map and Register Definition**

This section provides a detailed description of all registers accessible in the 9S12I32PIMV1 module.

**4.29.3.1 Register Descriptions**

This section describes in address order all the 9S12I32PIMV1 registers and their individual bits.

**4.29.3.1.1 Interrupt Vector Base Register (IVBR)**

**Table 249. Interrupt Vector Base Register (IVBR)**

Address: 0x001F

	7	6	5	4	3	2	1	0
R	IVB_ADDR[7:0]							
W								
Reset	1	1	1	1	1	1	1	1

Read: Anytime

Write: Anytime

**Table 250. IVBR Field Descriptions**

Field	Description
7–0 IVB_ADDR[7:0]	<p><b>Interrupt Vector Base Address Bits</b> — These bits represent the upper byte of all vector addresses. Out of reset these bits are set to 0xFF (i.e., vectors are located at 0xFF80–0xFFFE) to ensure compatibility to HCS12.</p> <p><b>Note:</b> A system reset initializes the interrupt vector base register with “0xFF” before it is used to determine the reset vector address. Therefore, changing the IVBR has no effect on the location of the three reset vectors (0xFFFA–0xFFFE).</p> <p><b>Note:</b> If the BDM is active (i.e., the CPU is in the process of executing BDM firmware code), the contents of IVBR are ignored and the upper byte of the vector address is fixed as “0xFF”. This is done to enable handling of all non-maskable interrupts in the BDM firmware.</p>

#### 4.29.4 Functional Description

The 9S12I32PIMV1 module processes all exception requests to be serviced by the CPU module. These exceptions include interrupt vector requests and reset vector requests. Each of these exception types and their overall priority level is discussed in the subsections below.

##### 4.29.4.1 S12S Exception Requests

The CPU handles both reset requests and interrupt requests. A priority decoder is used to evaluate the priority of pending interrupt requests.

##### 4.29.4.2 Interrupt Prioritization

###### NOTE

All non I bit maskable interrupt requests always have higher priority than the I bit maskable interrupt requests. If the X bit in the CCR is cleared, it is possible to interrupt an I bit maskable interrupt by an X bit maskable interrupt. It is possible to nest non maskable interrupt requests, e.g., by nesting SWI or TRAP calls.

Care must be taken to ensure all interrupt requests remain active until the system begins execution of the applicable service routine. Otherwise, the exception request may not get processed at all or the result may be a spurious interrupt request (vector at address (vector base + 0x0080)).

The 9S12I32PIMV1 module contains a priority decoder to determine the priority for all interrupt requests pending for the CPU. If more than one interrupt request is pending, the interrupt request with the higher vector address wins the prioritization.

The following conditions must be met for an I bit maskable interrupt request to be processed.

1. The local interrupt enabled bit in the peripheral module must be set.
2. The I bit in the condition code register (CCR) of the CPU must be cleared.
3. There is no SWI, TRAP, or X bit maskable request pending.

Since an interrupt vector is only supplied at the time when the CPU requests it, it is possible a higher priority interrupt request could override the original interrupt request causing the CPU to request the vector. In this case, the CPU receives the highest priority vector and the system processes this interrupt request first, before the original interrupt request is processed.

If the interrupt source is unknown (for example, in the case where an interrupt request becomes inactive after the interrupt has been recognized, but prior to the CPU vector request), the vector address supplied to the CPU defaults to the spurious interrupt vector.

##### 4.29.4.3 Reset Exception Requests

The 9S12I32PIMV1 module supports three system reset exception request types (refer to CRG for details):

1. Pin reset, power-on reset or illegal address reset
2. Clock monitor reset request
3. COP watchdog reset request

#### 4.29.4.4 Exception Priority

The priority (from highest to lowest) and address of all exception vectors issued by the 9S12132PIMV1 module upon request by the CPU is shown in Table 251.

**Table 251. Exception Vector Map and Priority**

Vector Address <sup>(175)</sup>	Source
0xFFFFE	Pin reset, power-on reset, illegal address reset
0xFFFFC	Clock monitor reset
0xFFFFA	COP watchdog reset
(Vector base + 0x00F8)	Unimplemented opcode trap
(Vector base + 0x00F6)	Software interrupt instruction (SWI) or BDM vector request
(Vector base + 0x00F4)	X bit maskable interrupt request (D2DI error interrupt)
(Vector base + 0x00F2)	D2DI interrupt request
(Vector base + 0x00F0–0x0082)	Device specific I bit maskable interrupt sources (priority determined by the low byte of the vector address, in descending order)
(Vector base + 0x0080)	Spurious interrupt

Note:

175. 16 bits vector address based

#### 4.29.5 Initialization/Application Information

##### 4.29.5.1 Initialization

After system reset, software should:

1. Initialize the interrupt vector base register if the interrupt vector table is not located at the default location (0xFF80–0xFFFF9).
2. Enable I bit maskable interrupts by clearing the I bit in the CCR.
3. Enable the X bit maskable interrupt by clearing the X bit in the CCR.

##### 4.29.5.2 Interrupt Nesting

The interrupt request scheme makes it possible to nest I bit maskable interrupt requests handled by the CPU.

- I bit maskable interrupt requests can be interrupted by an interrupt request with a higher priority.

I bit maskable interrupt requests cannot be interrupted by other I bit maskable interrupt requests, per default. In order to make an interrupt service routine (ISR) interruptible, the ISR must explicitly clear the I bit in the CCR (CLI). After clearing the I bit, other I bit maskable interrupt requests can interrupt the current ISR.

An ISR of an interruptible I bit maskable interrupt request could basically look like this:

1. Service interrupt, e.g., clear interrupt flags, copy data, etc.
2. Clear I bit in the CCR by executing the instruction CLI (thus allowing other I bit maskable interrupt requests)
3. Process data
4. Return from interrupt by executing the instruction RTI

### 4.29.5.3 Wake-up from Stop or Wait Mode

#### 4.29.5.3.1 CPU Wake-up from Stop or Wait Mode

Every I bit maskable interrupt request is capable of waking the MCU from stop or wait mode. To determine whether an I bit maskable interrupt is qualified to wake-up the CPU or not, the same conditions as in normal run mode are applied during stop or wait mode:

- If the I bit in the CCR is set, all I bit maskable interrupts are masked from wake-up the MCU.

Since there are no clocks running in stop mode, only interrupts which can be asserted asynchronously can wake-up the MCU from stop mode.

## 4.30 Background Debug Module (S12SBDMV1)

### 4.30.1 Introduction

This section describes the functionality of the background debug module (BDM) sub-block of the HCS12S core platform. The background debug module (BDM) sub-block is a single-wire, background debug system implemented in on-chip hardware for minimal CPU intervention. All interfacing with the BDM is done via the BKGD pin.

The BDM has enhanced capability for maintaining synchronization between the target and host while allowing more flexibility in clock rates. This includes a sync signal to determine the communication rate and a handshake signal to indicate when an operation is complete. The system is backwards compatible to the BDM of the S12 family with the following exceptions:

- TAGGO command not supported by S12SBDM
- External instruction tagging feature is part of the DBG module
- S12SBDM register map and register content modified
- Family ID readable from firmware ROM at global address 0x3\_FF0F (value for devices with HCS12S core is 0xC2)
- Clock switch removed from BDM (CLKSW bit removed from BDMSTS register)

#### 4.30.1.1 Features

The BDM includes these distinctive features:

- Single-wire communication with host development system
- Enhanced capability for allowing more flexibility in clock rates
- SYNC command to determine communication rate
- GO\_UNTIL command
- Hardware handshake protocol to increase the performance of the serial communication
- Active out of reset in special single chip mode
- Nine hardware commands using free cycles, if available, for minimal CPU intervention
- Hardware commands not requiring active BDM
- 14 firmware commands execute from the standard BDM firmware lookup table
- Software control of BDM operation during wait mode
- When secured, hardware commands are allowed to access the register space in special single chip mode, if the Flash and EEPROM erase tests fail.
- Family ID readable from firmware ROM at global address 0x3\_FF0F (value for devices with HCS12S core is 0xC2)
- BDM hardware commands are operational until system stop mode is entered

#### 4.30.1.2 Modes of Operation

BDM is available in all operating modes but must be enabled before firmware commands are executed. Some systems may have a control bit suspending the function during background debug mode.

**4.30.1.2.1 Regular Run Modes**

All of these operations refer to the part in run mode and not being secured. The BDM does not provide controls to conserve power during run mode.

- Normal modes  
General operation of the BDM is available and operates the same in all normal modes.
- Special single chip mode  
In special single chip mode, background operation is enabled and active out of reset. This allows programming a system with blank memory.

**4.30.1.2.2 Secure Mode Operation**

If the device is in secure mode, the operation of the BDM is reduced to a small subset of its regular run mode operation. Secure operation prevents access to Flash or EEPROM other than allowing erasure. For more information, see [Section 4.30.4.1, "Security"](#).

**4.30.1.2.3 Low Power Modes**

The BDM can be used until stop mode is entered. When CPU is in wait mode all BDM firmware commands as well as the hardware BACKGROUND command cannot be used and are ignored. In this case the CPU can not enter BDM active mode, and only hardware read and write commands are available. Also the CPU can not enter a low power mode (stop or wait) during BDM active mode.

In stop mode, the BDM clocks are stopped. When BDM clocks are disabled and stop mode is exited, the BDM clocks restarts and the BDM has a soft reset (clearing the instruction register, any command in progress and disable the ACK function). The BDM is now ready to receive a new command.

**4.30.1.3 Block Diagram**

A block diagram of the BDM is shown in [Figure 58](#).

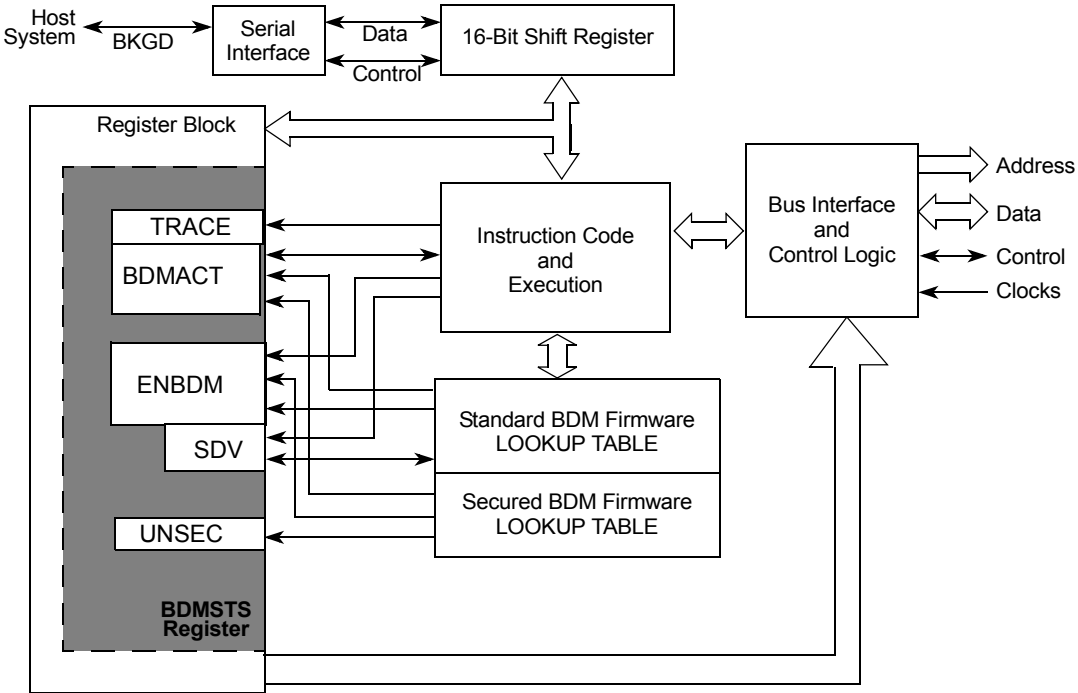

**Figure 58. BDM Block Diagram**

## 4.30.2 External Signal Description

A single-wire interface pin called the background debug interface (BKGD) pin is used to communicate with the BDM system. During reset, this pin is a mode select input which selects between normal and special modes of operation. After reset, this pin becomes the dedicated serial interface pin for the background debug mode. The communication rate of this pin is based on the DCO clock or external reference clock depending on the configuration selected (refer to the S12S\_CRG Block Guide for more details) which gets divided by five. Hence the BDM serial interface clock is always DCO clock divided by five after reset in to Special Single Chip mode which is about 6.4 MHz. After reset the BDM communication rate can be modified either via BDM command or CPU user code. When modifying the DCO clock make sure the communication rate is adapted accordingly and a communication timeout (BDM soft reset) has occurred.

## 4.30.3 Memory Map and Register Definition

### 4.30.3.1 Module Memory Map

Table 252 shows the BDM memory map when BDM is active.

**Table 252. BDM Memory Map**

Global Address	Module	Size (Bytes)
0x3_FF00–0x3_FF0B	BDM registers	12
0x3_FF0C–0x3_FF0E	BDM firmware ROM	3
0x3_FF0F	Family ID (part of BDM firmware ROM)	1
0x3_FF10–0x3_FFFF	BDM firmware ROM	240

### 4.30.3.2 Register Descriptions

A summary of the registers associated with the BDM is shown in Table 253. Registers are accessed by host-driven communications to the BDM hardware using READ\_BD and WRITE\_BD commands.

**Table 253. BDM Register Summary**

Global Address	Register Name		Bit 7	6	5	4	3	2	1	Bit 0
0x3_FF00	Reserved	R	X	X	X	X	X	X	0	0
		W								
0x3_FF01	BDMSTS	R	ENBDM	BDMACT	0	SDV	TRACE	0	UNSEC	0
		W								
0x3_FF02	Reserved	R	X	X	X	X	X	X	X	X
		W								
0x3_FF03	Reserved	R	X	X	X	X	X	X	X	X
		W								
0x3_FF04	Reserved	R	X	X	X	X	X	X	X	X
		W								
0x3_FF05	Reserved	R	X	X	X	X	X	X	X	X
		W								
0x3_FF06	BDMCCR	R	CCR7	CCR6	CCR5	CCR4	CCR3	CCR2	CCR1	CCR0
		W								
0x3_FF07	Reserved	R	0	0	0	0	0	0	0	0
		W								

**Table 253. BDM Register Summary (continued)**

Global Address	Register Name		Bit 7	6	5	4	3	2	1	Bit 0
0x3_FF08	BDMPPR	R	BPAE	0	0	0	BPP3	BPP2	BPP1	BPP0
		W								
0x3_FF09	Reserved	R	0	0	0	0	0	0	0	0
		W								
0x3_FF0A	Reserved	R	0	0	0	0	0	0	0	0
		W								
0x3_FF0B	Reserved	R	0	0	0	0	0	0	0	0
		W								

#### 4.30.3.2.1 BDM Status Register (BDMSTS)

**Table 254. Register Global Address 0x3\_FF01**

	7	6	5	4	3	2	1	0
R	ENBDM	BDMACT	0	SDV	TRACE	0	UNSEC	0
W								
Reset								
Special Single-Chip Mode	0 <sup>(176)</sup>	1	0	0	0	0	0 <sup>(177)</sup>	0
All Other Modes	0	0	0	0	0	0	0	0

- Note:
176. ENBDM is read as 1 by a debugging environment in special single chip mode when the device is not secured or secured but fully erased (Flash). This is because the ENBDM bit is set by the standard firmware before a BDM command can be fully transmitted and executed.
  177. UNSEC is read as 1 by a debugging environment in special single chip mode when the device is secured and fully erased, else it is 0 and can only be read if not secure (see also bit description).

#### 4.30.3.2.2 BDM Status Register (BDMSTS)

##### NOTE

When BDM is made active, the CPU stores the content of its CCR register in the BDMCCR register. However, out of special single-chip reset, the BDMCCR is set to 0xD8 and not 0xD0, which is the reset value of the CCR register in this CPU mode. Out of reset in all other modes, the BDMCCR register is read zero.

Read: All modes through BDM operation when not secured

Write: All modes through BDM operation when not secured, but subject to the following:

- ENBDM should only be set via a BDM hardware command if the BDM firmware commands are needed. (This does not apply in special single chip mode).
- BDMACT can only be set by BDM hardware upon entry into BDM. It can only be cleared by the standard BDM firmware lookup table upon exit from BDM active mode.
- All other bits, while writable via BDM hardware or standard BDM firmware write commands, should only be altered by the BDM hardware or standard firmware lookup table as part of BDM command execution.

**Table 255. BDMSTS Field Descriptions**

Field	Description
7 ENBDM	<p><b>Enable BDM</b> — This bit controls whether the BDM is enabled or disabled. When enabled, BDM can be made active to allow firmware commands to be executed. When disabled, BDM cannot be made active but BDM hardware commands are still allowed.</p> <p>0 BDM disabled 1 BDM enabled</p> <p><b>Note:</b> ENBDM is set by the firmware out of reset in special single chip mode. In special single-chip mode with the device secured, this bit is not set by the firmware until after the Flash erase verify tests are complete.</p>
6 BDMACT	<p><b>BDM Active Status</b> — This bit becomes set upon entering BDM. The standard BDM firmware lookup table is then enabled and put into the memory map. BDMACT is cleared by a carefully timed store instruction in the standard BDM firmware as part of the exit sequence to return to user code and remove the BDM memory from the map.</p> <p>0 BDM not active 1 BDM active</p>
4 SDV	<p><b>Shift Data Valid</b> — This bit is set and cleared by the BDM hardware. It is set after data has been transmitted as part of a firmware or hardware read command or after data has been received as part of a firmware or hardware write command. It is cleared when the next BDM command has been received or BDM is exited. SDV is used by the standard BDM firmware to control program flow execution.</p> <p>0 Data phase of command not complete 1 Data phase of command is complete</p>
3 TRACE	<p><b>TRACE1 BDM Firmware Command is Being Executed</b> — This bit gets set when a BDM TRACE1 firmware command is first recognized. It stays set until BDM firmware is exited by one of the following BDM commands: GO or GO_UNTIL.</p> <p>0 TRACE1 command is not being executed 1 TRACE1 command is being executed</p>
1 UNSEC	<p><b>Unsecure</b> — If the device is secured this bit is only writable in special single-chip mode from the BDM secure firmware. It is in a zero state as secure mode is entered so the secure BDM firmware lookup table is enabled and put into the memory map overlapping the standard BDM firmware lookup table.</p> <p>The secure BDM firmware lookup table verifies the on-chip Flash is erased. This being the case, the UNSEC bit is set and the BDM program jumps to the start of the standard BDM firmware lookup table and the secure BDM firmware lookup table is turned off. If the erase test fails, the UNSEC bit is not asserted.</p> <p>0 System is in a secured mode. 1 System is in a unsecured mode.</p> <p><b>Note:</b> When UNSEC is set, security is off and the user can change the state of the secure bits in the on-chip Flash EEPROM. Note that if the user does not change the state of the bits to “unsecured” mode, the system is secured again when it is next taken out of reset. After reset this bit has no meaning or effect when the security byte in the Flash EEPROM is configured for unsecure mode.</p>

**Table 256. BDM CCR Holding Register (BDMCCR)**

Register Global Address 0x3_FF06	7	6	5	4	3	2	1	0
R								
W								
Reset								
Special Single-chip Mode	1	1	0	0	1	0	0	0
All Other Modes	0	0	0	0	0	0	0	0

Read: All modes through BDM operation when not secured

Write: All modes through BDM operation when not secured

When entering background debug mode, the BDM CCR holding register is used to save the condition code register of the user’s program. It is also used for temporary storage in the standard BDM firmware mode. The BDM CCR holding register can be written to modify the CCR value.

### 4.30.3.2.3 BDM Program Page Index Register (BDMPPR)

**Table 257. BDM Program Page Register (BDMPPR)**

Register Global Address 0x3_FF08	7	6	5	4	3	2	1	0
R	BPAE	0	0	0	BPP3	BPP2	BPP1	BPP0
W								
Reset	0	0	0	0	0	0	0	0

Read: All modes through BDM operation when not secured

Write: All modes through BDM operation when not secured

**Table 258. BDMPPR Field Descriptions**

Field	Description
7 BPAE	<b>BDM Program Page Access Enable Bit</b> — BPAE enables program page access for BDM hardware and firmware read/write instructions. The BDM hardware commands used to access the BDM registers (READ_BD and WRITE_BD), and cannot be used for global accesses even if the BGAE bit is set. 0 BDM Program Paging disabled 1 BDM Program Paging enabled
3–0 BPP[3:0]	<b>BDM Program Page Index Bits 3–0</b> — These bits define the selected program page. For more detailed information regarding the program page window scheme, refer to the S12S_MMC Block Guide.

### 4.30.3.3 Family ID Assignment

The family ID is a 8-bit value located in the firmware ROM (at global address: 0x3\_FF0F). The read-only value is a unique family ID which is 0xC2 for devices with HCS12S core.

### 4.30.4 Functional Description

The BDM receives and executes commands from a host via a single wire serial interface. There are two types of BDM commands: hardware and firmware commands.

Hardware commands are used to read and write target system memory locations and to enter active background debug mode, see [Section 4.30.4.3, “BDM Hardware Commands”](#). Target system memory includes all memory accessible by the CPU.

Firmware commands are used to read and write CPU resources and to exit from active background debug mode, see [Section 4.30.4.4, “Standard BDM Firmware Commands”](#). The CPU resources referred to are the accumulator (D), X index register (X), Y index register (Y), stack pointer (SP), and program counter (PC).

Hardware commands can be executed at any time and in any mode excluding a few exceptions as highlighted (see [Section 4.30.4.3, “BDM Hardware Commands”](#)), and in secure mode (see [Section 4.30.4.1, “Security”](#)). Firmware commands can only be executed when the system is not secure and is in active background debug mode (BDM).

#### 4.30.4.1 Security

If the user resets into special single-chip mode with the system secured, a secured mode BDM firmware lookup table is brought into the map overlapping a portion of the standard BDM firmware lookup table. The secure BDM firmware verifies the on-chip EEPROM and Flash EEPROM are erased. This being the case, the UNSEC and ENBDM bit gets set. The BDM program jumps to the start of the standard BDM firmware and the secured mode BDM firmware is turned off and all BDM commands are allowed. If the EEPROM or Flash do not verify as erased, the BDM firmware sets the ENBDM bit, without asserting UNSEC, and the firmware enters a loop. This causes the BDM hardware commands to become enabled, but does not enable the firmware commands. This allows the BDM hardware to be used to erase the EEPROM and Flash.

BDM operation is not possible in any other mode than special single-chip mode when the device is secured. The device can only be unsecured via BDM serial interface in special single-chip mode. For more information regarding security, see the S12S\_9SEC Block Guide.

#### 4.30.4.2 Enabling and Activating BDM

##### NOTE

If an attempt is made to activate BDM before being enabled, the CPU resumes normal instruction execution after a brief delay. If BDM is not enabled, any hardware BACKGROUND commands issued are ignored by the BDM and the CPU is not delayed.

The system must be in active BDM to execute standard BDM firmware commands. BDM can be activated only after being enabled. BDM is enabled by setting the ENBDM bit in the BDM status (BDMSTS) register. The ENBDM bit is set by writing to the BDM status (BDMSTS) register, via the single-wire interface, using a hardware command such as WRITE\_BD\_BYTE.

After being enabled, BDM is activated by one of the following (BDM is enabled and active immediately out of special single-chip reset):

- Hardware BACKGROUND command
- CPU BGND instruction
- Breakpoint force or tag mechanism (This method is provided by the S12S\_DBG module)

When BDM is activated, the CPU finishes executing the current instruction, and then begins executing the firmware in the standard BDM firmware lookup table. When BDM is activated by a breakpoint, the type of breakpoint used determines if BDM becomes active before or after execution of the next instruction.

In active BDM, the BDM registers and standard BDM firmware lookup table are mapped to addresses 0x3\_FF00 to 0x3\_FFFF. BDM registers are mapped to addresses 0x3\_FF00 to 0x3\_FF0B. The BDM uses these registers which are readable anytime by the BDM. However, these registers are not readable by user programs.

When BDM is activated while CPU executes code overlapping with BDM firmware space the saved program counter (PC) is auto incremented by one from the BDM firmware, no matter what caused the entry into BDM active mode (BGND instruction, BACKGROUND command or breakpoints). In such a case the PC must be set to the next valid address via a WRITE\_PC command before executing the GO command.

#### 4.30.4.3 BDM Hardware Commands

Hardware commands are used to read and write target system memory locations and to enter active background debug mode. Target system memory includes all memory accessible by the CPU such as on-chip RAM, Flash, I/O and control registers.

Hardware commands are executed with minimal or no CPU intervention and do not require the system to be in active BDM for execution, although, they can still be executed in this mode. When executing a hardware command, the BDM sub-block waits for a free bus cycle so the background access does not disturb the running application program. If a free cycle is not found within 128 clock cycles, the CPU is momentarily frozen so the BDM can steal a cycle. When the BDM finds a free cycle, the operation does not intrude on normal CPU operation provided it can be completed in a single cycle. However, if an operation requires multiple cycles the CPU is frozen until the operation is complete, even though the BDM found a free cycle.

The BDM hardware commands are listed in [Table 259](#).

The READ\_BD and WRITE\_BD commands allow access to the BDM register locations. These locations are not normally in the system memory map but share addresses with the application in memory. To distinguish between physical memory locations sharing the same address, BDM memory resources are enabled just for the READ\_BD and WRITE\_BD access cycle. This allows the BDM to access BDM locations unobtrusively, even if the addresses conflict with the application memory map.

If ACK pulse is enabled, an ACK pulse occurs when data is ready for transmission for all BDM READ commands and occurs after the write is complete for all BDM WRITE commands

**Table 259. Hardware Commands**

Command	Opcode (hex)	Data	Description
BACKGROUND	90	None	Enter background mode if firmware is enabled. If enabled, an ACK is issued when the part enters active background mode.
ACK_ENABLE	D5	None	Enable Handshake. Issues an ACK pulse after the command is executed.
ACK_DISABLE	D6	None	Disable Handshake. This command does not issue an ACK pulse.
READ_BD_BYTE	E4	16-bit address 16-bit data out	Read from memory with standard BDM firmware lookup table in map. Odd address data on low byte; even address data on high byte.
READ_BD_WORD	EC	16-bit address 16-bit data out	Read from memory with standard BDM firmware lookup table in map. Must be aligned access.
READ_BYTE	E0	16-bit address 16-bit data out	Read from memory with standard BDM firmware lookup table out of map. Odd address data on low byte; even address data on high byte.
READ_WORD	E8	16-bit address 16-bit data out	Read from memory with standard BDM firmware lookup table out of map. Must be aligned access.
WRITE_BD_BYTE	C4	16-bit address 16-bit data in	Write to memory with standard BDM firmware lookup table in map. Odd address data on low byte; even address data on high byte.
WRITE_BD_WORD	CC	16-bit address 16-bit data in	Write to memory with standard BDM firmware lookup table in map. Must be aligned access.
WRITE_BYTE	C0	16-bit address 16-bit data in	Write to memory with standard BDM firmware lookup table out of map. Odd address data on low byte; even address data on high byte.
WRITE_WORD	C8	16-bit address 16-bit data in	Write to memory with standard BDM firmware lookup table out of map. Must be aligned access.

#### 4.30.4.4 Standard BDM Firmware Commands

Firmware commands are used to access and manipulate CPU resources. The system must be in active BDM to execute standard BDM firmware commands, see [Section 4.30.4.2, "Enabling and Activating BDM"](#). Normal instruction execution is suspended while the CPU executes the firmware located in the standard BDM firmware lookup table. The hardware command BACKGROUND is the usual way to activate BDM.

As the system enters active BDM, the standard BDM firmware lookup table and BDM registers become visible in the on-chip memory map at 0x3\_FF00–0x3\_FFFF, and the CPU begins executing the standard BDM firmware. The standard BDM firmware watches for serial commands and executes them as they are received.

The firmware commands are shown in [Table 260](#).

**Table 260. Firmware Commands**

Command <sup>(178)</sup>	Opcode (hex)	Data	Description
READ_NEXT <sup>(179)</sup>	62	16-bit data out	Increment X index register by 2 ( $X = X + 2$ ), then read word X points to.
READ_PC	63	16-bit data out	Read program counter.
READ_D	64	16-bit data out	Read D accumulator.
READ_X	65	16-bit data out	Read X index register.
READ_Y	66	16-bit data out	Read Y index register.
READ_SP	67	16-bit data out	Read stack pointer.
WRITE_NEXT	42	16-bit data in	Increment X index register by 2 ( $X = X + 2$ ), then write word to location pointed to by X.
WRITE_PC	43	16-bit data in	Write program counter.

**Table 260. Firmware Commands (continued)**

Command <sup>(178)</sup>	Opcode (hex)	Data	Description
WRITE_D	44	16-bit data in	Write D accumulator.
WRITE_X	45	16-bit data in	Write X index register.
WRITE_Y	46	16-bit data in	Write Y index register.
WRITE_SP	47	16-bit data in	Write stack pointer.
GO	08	none	Go to user program. If enabled, ACK occurs when leaving active background mode.
GO_UNTIL <sup>(180)</sup>	0C	none	Go to user program. If enabled, ACK occurs upon returning to active background mode.
TRACE1	10	none	Execute one user instruction then return to active BDM. If enabled, ACK occurs upon returning to active background mode.
TAGGO -> GO	18	none	(Previous enable tagging and go to user program.) This command is deprecated and should not be used anymore. Opcode is executed as a GO command.

Note:

- 178. If enabled, ACK occurs when data is ready for transmission for all BDM READ commands and occurs after the write is complete for all BDM WRITE commands.
- 179. When the firmware command READ\_NEXT or WRITE\_NEXT is used to access the BDM address space the BDM resources are accessed rather than user code. Writing BDM firmware is not possible.
- 180. System stop disables the ACK function and ignored commands does not have an ACK-pulse (e.g., CPU in stop or wait mode). The GO\_UNTIL command does not get an Acknowledge if CPU executes the wait or stop instruction before the "UNTIL" condition (BDM active again) is reached (see Section 4.30.4.7, "Serial Interface Hardware Handshake Protocol" last Note).

#### 4.30.4.5 BDM Command Structure

##### NOTE

If the bus rate of the target processor is unknown or could be changing, it is recommended the ACK (acknowledge function) is used to indicate when an operation is complete. When using ACK, the delay times are automated.

Hardware and firmware BDM commands start with an 8-bit opcode followed by a 16-bit address and/or a 16-bit data word depending on the command. All the read commands return 16-bits of data despite the byte or word implication in the command name.

8-bit reads return 16-bits of data, of which, only one byte contains valid data. If reading an even address, the valid data appears in the MSB. If reading an odd address, the valid data appears in the LSB.

16-bit misaligned reads and writes are generally not allowed. If attempted by BDM hardware command, the BDM ignores the least significant bit of the address and assumes an even address from the remaining bits.

For hardware data read commands, the external host must wait at least 150 bus clock cycles after sending the address before attempting to obtain the read data. This is to be certain valid data is available in the BDM shift register, ready to be shifted out. For hardware write commands, the external host must wait 150 bus clock cycles after sending the data to be written before attempting to send a new command. This is to avoid disturbing the BDM shift register before the write has been completed. The 150 bus clock cycle delay in both cases includes the maximum 128 cycle delay can be incurred as the BDM waits for a free cycle before stealing a cycle.

For firmware read commands, the external host should wait at least 48 bus clock cycles after sending the command opcode and before attempting to obtain the read data. The 48 cycle wait allows enough time for the requested data to be made available in the BDM shift register, ready to be shifted out.

For firmware write commands, the external host must wait 36 bus clock cycles after sending the data to be written before attempting to send a new command. This is to avoid disturbing the BDM shift register before the write has been completed.

The external host should wait at least for 76 bus clock cycles after a TRACE1 or GO command before starting any new serial command. This is to allow the CPU to exit gracefully from the standard BDM firmware lookup table and resume execution of the user code. Disturbing the BDM shift register prematurely may adversely affect the exit from the standard BDM firmware lookup table.

Figure 59 represents the BDM command structure. The command blocks illustrate a series of eight bit times starting with a falling edge. The bar across the top of the blocks indicates the BKGD line idles in the high state. The time for an 8-bit command is  $8 \times 16$  target clock cycles. Target clock cycles are cycles measured using the target MCU's serial clock rate. See Section 4.30.4.6, "BDM Serial Interface" and Section 4.30.3.2.1, "BDM Status Register (BDMSTS)" for information on how serial clock rate is selected.

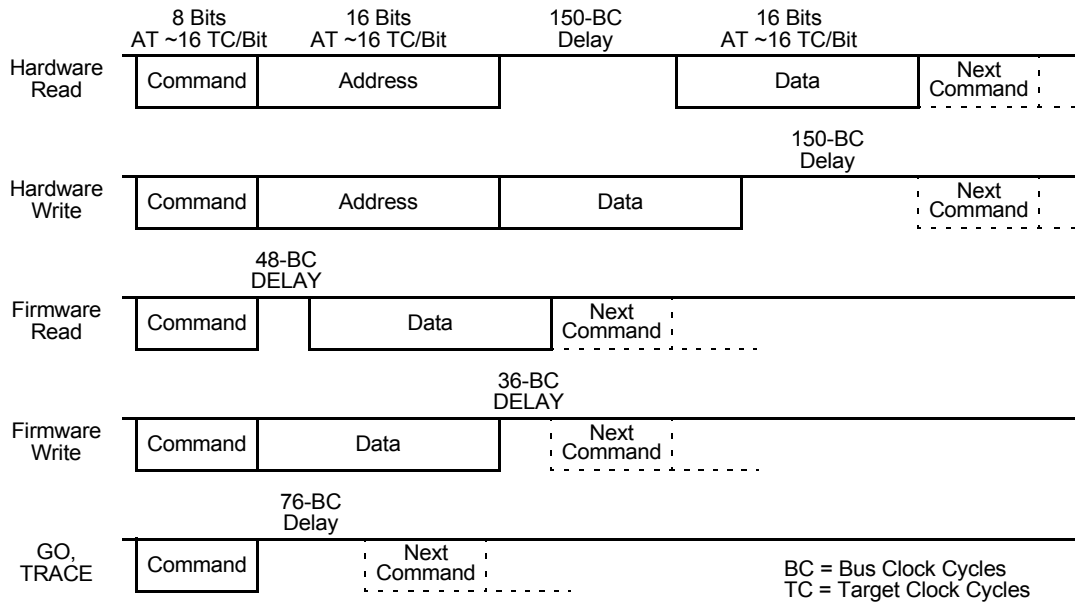

**Figure 59. BDM Command Structure**

**4.30.4.6 BDM Serial Interface**

The BDM communicates with external devices serially via the BKGD pin. During reset, this pin is a mode select input which selects between normal and special modes of operation. After reset, this pin becomes the dedicated serial interface pin for the BDM. The BDM serial interface is timed based on DCO clock or external reference clock depending on the configuration used (refer to the CRG Block Guide for more details), which gets divided by five. This clock is referred to as the target clock in the following explanation.

The BDM serial interface uses a clocking scheme in which the external host generates a falling edge on the BKGD pin to indicate the start of each bit time. This falling edge is sent for every bit whether data is transmitted or received. Data transfers the most significant bit (MSB) first at 16 target clock cycles per bit. The interface times out if 512 clock cycles occur between the falling edges from the host. The BKGD pin is a pseudo open-drain pin and has an weak on-chip active pull-up enabled at all times. It is assumed there is an external pull-up and drivers connected to BKGD do not typically drive the high level. Since R-C rise time could be unacceptably long, the target system and host provide brief driven high (speedup) pulses to drive BKGD to a logic 1. The source of this speedup pulse is the host for transmit cases and the target for receive cases.

The timing for a host-to-target is shown in Figure 60 and a target-to-host in Figure 61 and Figure 62. All four cases begin when the host drives the BKGD pin low to generate a falling edge. Since the host and target are operating from separate clocks, it can take the target system up to one full clock cycle to recognize this edge. The target measures delays from this perceived start of the bit time while the host measures delays from the point it actually drove BKGD low to start the bit up to one target clock cycle earlier. Synchronization between the host and target is established in this manner at the start of every bit time.

Figure 60 shows an external host transmitting a logic 1 and transmitting a logic 0 to the BKGD pin of a target system. The host is asynchronous to the target, so there is up to a one clock-cycle delay from the host-generated falling edge to where the target recognizes this edge as the beginning of the bit time. Ten target clock cycles later, the target senses the bit level on the BKGD pin. Internal glitch detect logic requires the pin be driven high no later than eight target clock cycles after the falling edge for a logic 1 transmission.

Since the host drives the high speedup pulses in these two cases, the rising edges look like digitally driven signals.

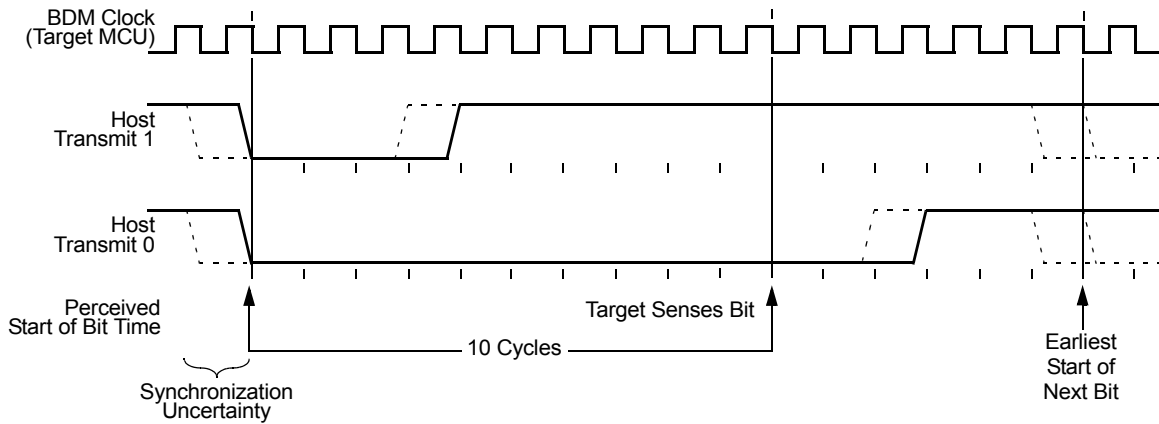

**Figure 60. BDM Host-to-Target Serial Bit Timing**

The receive cases are more complicated. [Figure 61](#) shows the host receiving a logic 1 from the target system. Since the host is asynchronous to the target, there is up to one clock-cycle delay from the host-generated falling edge on BKGD to the perceived start of the bit time in the target. The host holds the BKGD pin low long enough for the target to recognize it (at least two target clock cycles). The host must release the low drive before the target drives a brief high speedup pulse seven target clock cycles after the perceived start of the bit time. The host should sample the bit level about 10 target clock cycles after it started the bit time.

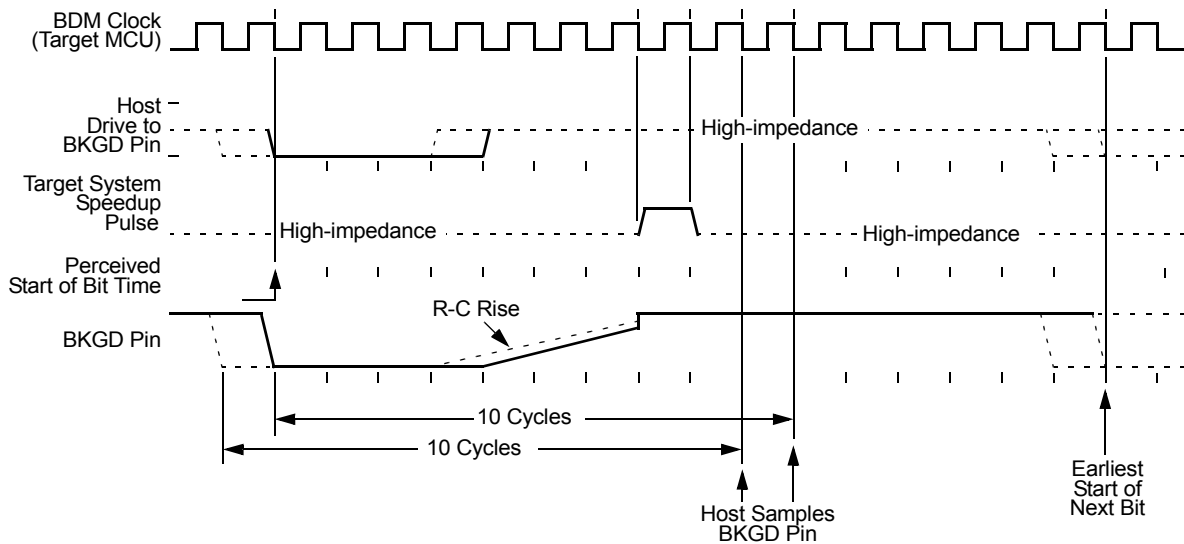

**Figure 61. BDM Target-to-Host Serial Bit Timing (Logic 1)**

[Figure 62](#) shows the host receiving a logic 0 from the target. Since the host is asynchronous to the target, there is up to a one clock-cycle delay from the host-generated falling edge on BKGD to the start of the bit time as perceived by the target. The host initiates the bit time but the target finishes it. Since the target wants the host to receive a logic 0, it drives the BKGD pin low for 13 target clock cycles then briefly drives it high to speed up the rising edge. The host samples the bit level about 10 target clock cycles after starting the bit time.

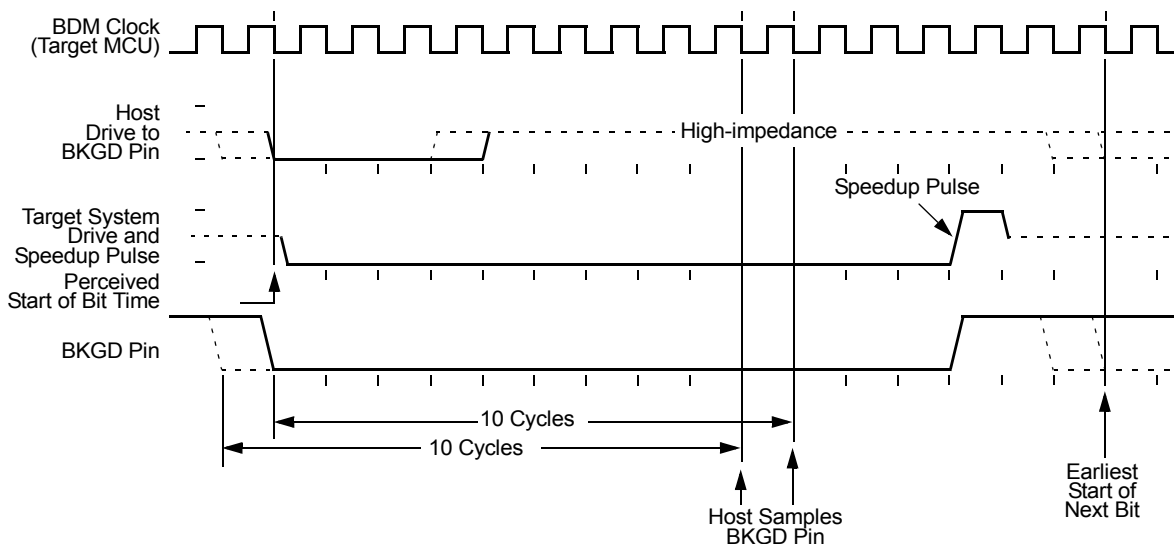

**Figure 62. BDM Target-to-Host Serial Bit Timing (Logic 0)**

**4.30.4.7 Serial Interface Hardware Handshake Protocol**

**NOTE**

If the ACK pulse was issued by the target, the host assumes the previous command was executed. If the CPU enters wait or stop prior to executing a hardware command, the ACK pulse is not issued meaning the BDM command was not executed. After entering wait or stop mode, the BDM command is no longer pending.

BDM commands which require CPU execution are ultimately treated at the MCU bus rate. Since the BDM clock source can be modified relative to the bus clock, when modifying DCO clock or the bus clock divider, it is very helpful to provide a handshake protocol in which the host could determine when an issued command is executed by the CPU. The alternative is to always wait the amount of time equal to the appropriate number of cycles at the slowest possible rate the clock could be running. This sub-section describes the hardware handshake protocol.

The hardware handshake protocol signals to the host controller when an issued command was successfully executed by the target. This protocol is implemented by a 16 serial clock cycle low pulse followed by a brief speedup pulse in the BKGD pin. This pulse is generated by the target MCU when a command, issued by the host, has been successfully executed (see Figure 63). This pulse is referred to as the ACK pulse. After the ACK pulse has finished: the host can start the bit retrieval if the last issued command was a read command, or start a new command if the last command was a write command or a control command (BACKGROUND, GO, GO\_UNTIL or TRACE1). The ACK pulse is not issued earlier than 32 serial clock cycles after the BDM command was issued. The end of the BDM command is assumed to be the 16th tick of the last bit. This minimum delay assures enough time for the host to perceive the ACK pulse. Note also that, there is no upper limit for the delay between the command and the related ACK pulse, since the command execution depends upon the CPU bus, which in some cases could be very slow due to long accesses taking place. This protocol allows a great flexibility for the POD designers, since it does not rely on any accurate time measurement or short response time to any event in the serial communication.

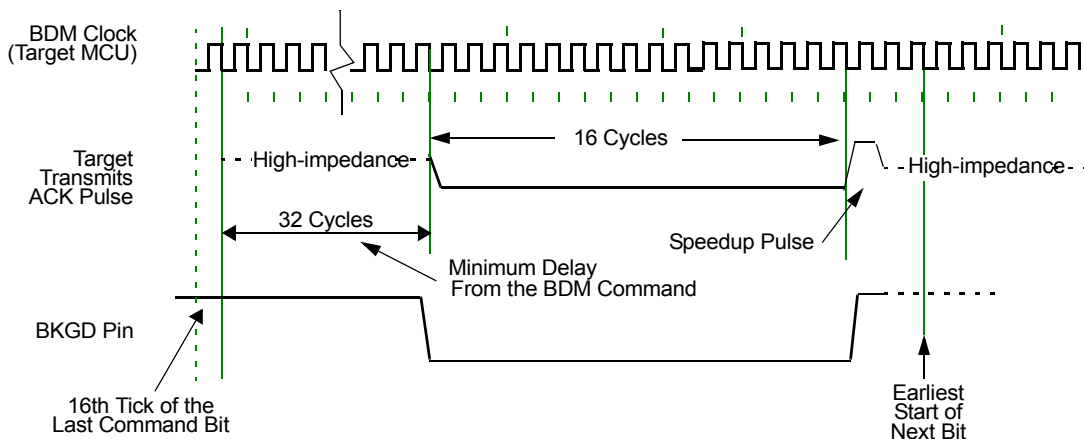

Figure 63. Target Acknowledge Pulse (ACK)

Figure 64 shows the ACK handshake protocol in a command level timing diagram. The READ\_BYTE instruction is used as an example. First, the 8-bit instruction opcode is sent by the host, followed by the address of the memory location to be read. The target BDM decodes the instruction. A bus cycle is grabbed (free or stolen) by the BDM and it executes the READ\_BYTE operation. Having retrieved the data, the BDM issues an ACK pulse to the host controller, indicating the addressed byte is ready to be retrieved. After detecting the ACK pulse, the host initiates the byte retrieval process. Note that data is sent in the form of a word and the host needs to determine which is the appropriate byte based on whether the address was odd or even.

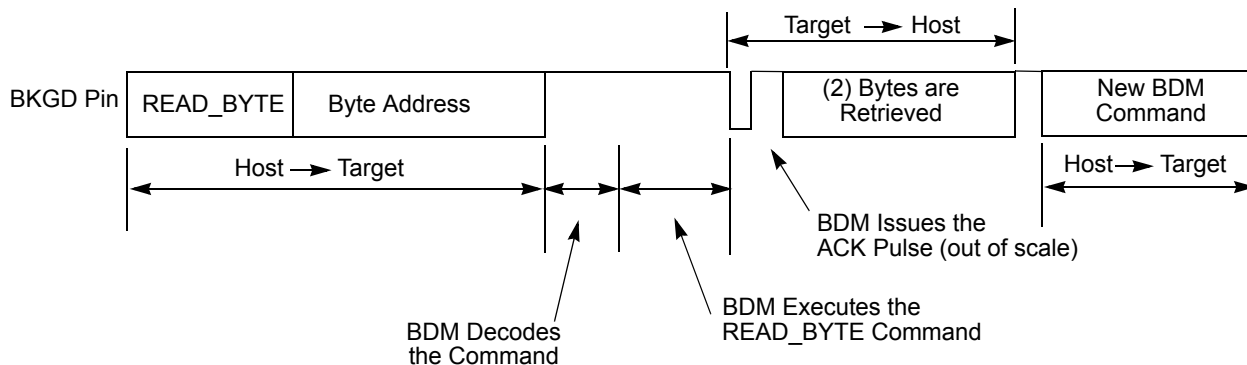

Figure 64. Handshake Protocol at Command Level

**NOTE**

The only place the BKGD pin can have an electrical conflict is when one side is driving low and the other side is issuing a speedup pulse (high). Other “highs” are pulled rather than driven. However, at low rates the time of the speedup pulse can become lengthy and so the potential conflict time becomes longer as well.

Differently from the normal bit transfer (where the host initiates the transmission), the serial interface ACK handshake pulse is initiated by the target MCU by issuing a negative edge in the BKGD pin. The hardware handshake protocol in Figure 63 specifies the timing when the BKGD pin is being driven, so the host should follow this timing constraint in order to avoid the risk of an electrical conflict in the BKGD pin.

**NOTE**

The ACK pulse does not provide a timeout. This means for the GO\_UNTIL command, it can not be distinguished if a stop or wait has been executed (command discarded and ACK not issued) or if the “UNTIL” condition (BDM active) is just not reached yet. Hence in any case where the ACK pulse of a command is not issued the possible pending command should be aborted before issuing a new command. See the handshake abort procedure described in Section 4.30.4.8, “Hardware Handshake Abort Procedure”.

The ACK handshake protocol does not support nested ACK pulses. If a BDM command is not acknowledge by an ACK pulse, the host needs to abort the pending command first in order to be able to issue a new BDM command. When the CPU enters wait or stop while the host issues a hardware command (e.g., WRITE\_BYTE), the target discards the incoming command due to the wait or stop being detected. Therefore, the command is not acknowledged by the target, which means the ACK pulse is not issued in this case. After a certain time the host (not aware of stop or wait) should decide to abort any possible pending ACK pulse in order to be sure a new command can be issued. Therefore, the protocol provides a mechanism in which a command, and its corresponding ACK, can be aborted.

**4.30.4.8 Hardware Handshake Abort Procedure**

The abort procedure is based on the SYNC command. In order to abort a command, which has not issued the corresponding ACK pulse, the host controller should generate a low pulse in the BKGD pin by driving it low for at least 128 serial clock cycles and then driving it high for one serial clock cycle, providing a speedup pulse. By detecting this long low pulse in the BKGD pin, the target executes the SYNC protocol, see Section 4.30.4.9, "SYNC — Request Timed Reference Pulse", and assumes the pending command and therefore the related ACK pulse, are being aborted. Therefore, after the SYNC protocol has been completed the host is free to issue new BDM commands. For Firmware READ or WRITE commands it can not be guaranteed the pending command is aborted when issuing a SYNC before the corresponding ACK pulse. There is a short latency time from the time the READ or WRITE access begins until it is finished and the corresponding ACK pulse is issued. The latency time depends on the firmware READ or WRITE command issued and on the selected bus clock rate. When the SYNC command starts during this latency time the READ or WRITE command is not aborted, but the corresponding ACK pulse is aborted. A pending GO, TRACE1 or GO\_UNTIL command can not be aborted. Only the corresponding ACK pulse can be aborted by the SYNC command.

**NOTE**

The details about the short abort pulse are being provided only as a reference for the reader to better understand the BDM internal behavior. It is not recommended this procedure be used in a real application.

Although it is not recommended, the host could abort a pending BDM command by issuing a low pulse in the BKGD pin shorter than 128 serial clock cycles, which is not interpreted as the SYNC command. The ACK is actually aborted when a negative edge is perceived by the target in the BKGD pin. The short abort pulse should have at least 4 clock cycles keeping the BKGD pin low, in order to allow the negative edge to be detected by the target. In this case, the target does not execute the SYNC protocol but the pending command is aborted along with the ACK pulse. The potential problem with this abort procedure is when there is a conflict between the ACK pulse and the short abort pulse. In this case, the target may not perceive the abort pulse. The worst case is when the pending command is a read command (i.e., READ\_BYTE). If the abort pulse is not perceived by the target the host attempts to send a new command after the abort pulse was issued, while the target expects the host to retrieve the accessed memory byte. In this case, host and target runs out of synchronism. However, if the command to be aborted is not a read command the short abort pulse could be used. After a command is aborted the target assumes the next negative edge, after the abort pulse, is the first bit of a new BDM command.

Since the host knows the target serial clock frequency, the SYNC command (used to abort a command) does not need to consider the lower possible target frequency. In this case, the host could issue a SYNC very close to the 128 serial clock cycles length. Providing a small overhead on the pulse length in order to assure the SYNC pulse is not misinterpreted by the target. See Section 4.30.4.9, "SYNC — Request Timed Reference Pulse".

Figure 65 shows a SYNC command being issued after a READ\_BYTE, which aborts the READ\_BYTE command. Note that, after the command is aborted, a new command could be issued by the host computer. Figure 65 does not represent the signals in a true timing scale

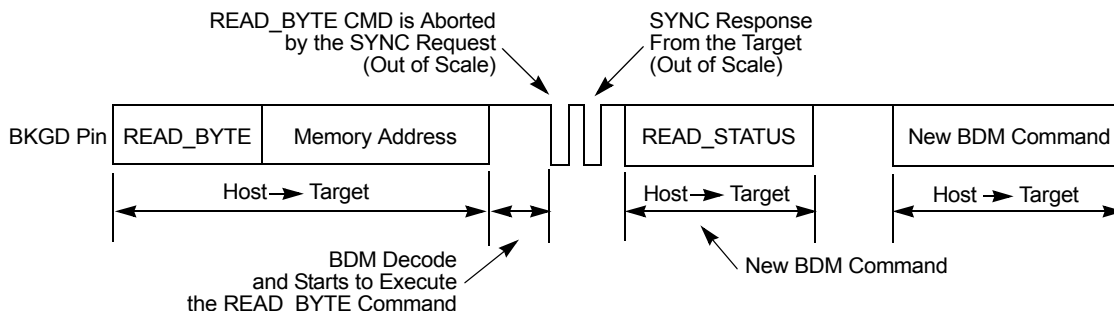
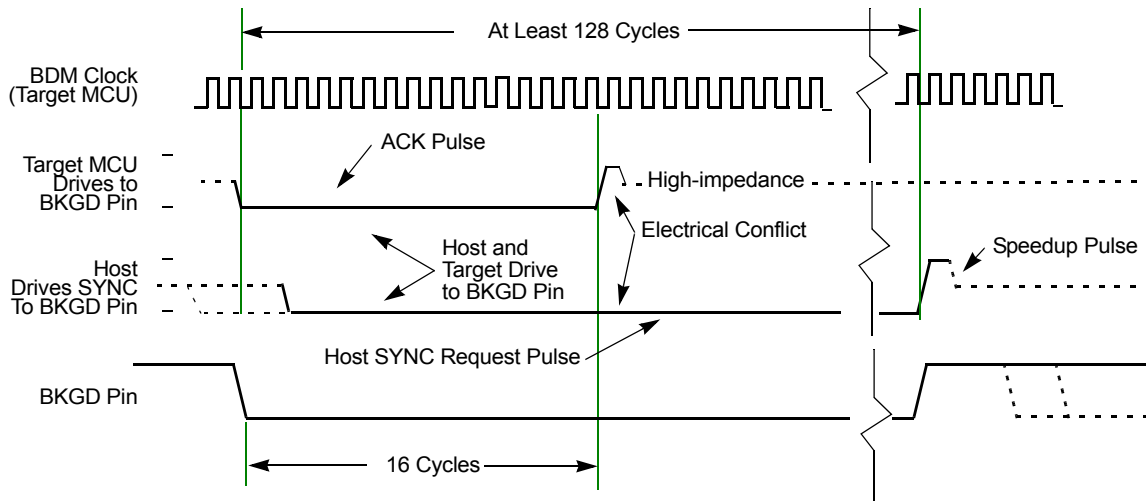

**Figure 65. ACK Abort Procedure at the Command Level**

Figure 66 shows a conflict between the ACK pulse and the SYNC request pulse. This conflict could occur if a POD device is connected to the target BKGD pin and the target is already in debug active mode. Consider that the target CPU is executing a pending BDM command at the exact moment the POD is being connected to the BKGD pin. In this case, an ACK pulse is issued along with the SYNC command. In this case, there is an electrical conflict between the ACK speedup pulse and the SYNC pulse. Since this is not a probable situation, the protocol does not prevent this conflict from happening.

**NOTE**

This information is being provided so the MCU integrator is aware such a conflict could occur.



**Figure 66. ACK Pulse and SYNC Request Conflict**

The hardware handshake protocol is enabled by the `ACK_ENABLE` and disabled by the `ACK_DISABLE` BDM commands. This provides backwards compatibility with the existing POD devices which are not able to execute the hardware handshake protocol. It also allows for new POD devices, supporting the hardware handshake protocol, freely communicate with the target device. If desired, without the need for waiting for the ACK pulse.

The commands are described as follows:

- `ACK_ENABLE` — enables the hardware handshake protocol. The target issues the ACK pulse when a CPU command is executed by the CPU. The `ACK_ENABLE` command itself also has the ACK pulse as a response.
- `ACK_DISABLE` — disables the ACK pulse protocol. In this case, the host needs to use the worst case delay time at the appropriate places in the protocol.

The default state of the BDM after reset is hardware handshake protocol disabled. All the read commands ACK (if enabled) when the data bus cycle has completed, and the data is then ready for reading out by the BKGD serial pin. All the write commands ACK (if enabled) after the data has been received by the BDM through the BKGD serial pin, and when the data bus cycle is complete. See [Section 4.30.4.3, "BDM Hardware Commands"](#) and [Section 4.30.4.4, "Standard BDM Firmware Commands"](#) for more information on the BDM commands.

The `ACK_ENABLE` sends an ACK pulse when the command has been completed. This feature could be used by the host to evaluate if the target supports the hardware handshake protocol. If an ACK pulse is issued in response to this command, the host knows the target supports the hardware handshake protocol. If the target does not support the hardware handshake protocol the ACK pulse is not issued. In this case, the `ACK_ENABLE` command is ignored by the target since it is not recognized as a valid command.

The BACKGROUND command issues an ACK pulse when the CPU changes from normal to background mode. The ACK pulse related to this command could be aborted using the SYNC command.

The GO command issues an ACK pulse when the CPU exits from background mode. The ACK pulse related to this command could be aborted using the SYNC command.

The GO\_UNTIL command is equivalent to a GO command with exception that the ACK pulse, in this case, is issued when the CPU enters into background mode. This command is an alternative to the GO command and should be used when the host wants to trace if a breakpoint match occurs, and causes the CPU to enter active background mode. Note that the ACK is issued whenever the CPU enters BDM, which could be caused by a breakpoint match or by a BGND instruction being executed. The ACK pulse related to this command could be aborted using the SYNC command.

The TRACE1 command has the related ACK pulse issued when the CPU enters background active mode after one instruction of the application program is executed. The ACK pulse related to this command could be aborted using the SYNC command.

#### 4.30.4.9 SYNC — Request Timed Reference Pulse

The SYNC command is unlike other BDM commands, because the host does not necessarily know the correct communication speed to use for BDM communications until after it has analyzed the response to the SYNC command. To issue a SYNC command, the host should perform the following steps:

1. Drive the BKGD pin low for at least 128 cycles at the lowest possible BDM serial communication frequency (the lowest serial communication frequency is determined by either DCO clock or external crystal oscillator depending on the configuration chosen in the CRG.)
2. Drive BKGD high for a brief speedup pulse to get a fast rise time (this speedup pulse is typically one cycle of the host clock.)
3. Remove all drive to the BKGD pin so it reverts to high-impedance.
4. Listen to the BKGD pin for the sync response pulse.

Upon detecting the SYNC request from the host, the target performs the following steps:

1. Discards any incomplete command received or bit retrieved.
2. Waits for BKGD to return to a logic one.
3. Delays 16 cycles to allow the host to stop driving the high speedup pulse.
4. Drives BKGD low for 128 cycles at the current BDM serial communication frequency.
5. Drives a one-cycle high speedup pulse to force a fast rise time on BKGD.
6. Removes all drive to the BKGD pin so it reverts to high-impedance.

The host measures the low time of this 128 cycle SYNC response pulse and determines the correct speed for subsequent BDM communications. Typically, the host can determine the correct communication speed within a few percent of the actual target speed, and the communication protocol can easily tolerate speed errors of several percent.

As soon as the SYNC request is detected by the target, any partially received command or bit retrieved is discarded. This is referred to as a soft-reset, equivalent to a timeout in the serial communication. After the SYNC response, the target considers the next negative edge (issued by the host) as the start of a new BDM command or the start of new SYNC request.

Another use of the SYNC command pulse is to abort a pending ACK pulse. The behavior is exactly the same as in a regular SYNC command. Note that one of the possible causes for a command not to be acknowledged by the target is a host-target synchronization problem. In this case, the command may not have been understood by the target and so an ACK response pulse is not issued.

#### 4.30.4.10 Instruction Tracing

When a TRACE1 command is issued to the BDM in active BDM, the CPU exits the standard BDM firmware and executes a single instruction in the user code. Once this has occurred, the CPU is forced to return to the standard BDM firmware, and the BDM is active and ready to receive a new command. If the TRACE1 command is issued again, the next user instruction is executed. This facilitates stepping or tracing through the user code one instruction at a time.

If an interrupt is pending when a TRACE1 command is issued, the interrupt stacking operation occurs but no user instruction is executed. Once back in standard BDM firmware execution, the program counter points to the first instruction in the interrupt service routine. Be aware when tracing through the user code the execution of the user code is done step by step but all peripherals are free running. Hence possible timing relations between CPU code execution and occurrence of events of other peripherals no longer exist.

Do not trace the CPU instruction BGND used for soft breakpoints. Tracing over the BGND instruction results in a return address pointing to BDM firmware address space. When tracing through user code which contains stop or wait instructions the following happens when the stop or wait instruction is traced:

The CPU enters stop or wait mode and the TRACE1 command can not be finished before leaving the low power mode. This is the case because BDM active mode can not be entered after CPU executed the stop instruction. However all BDM hardware commands except the BACKGROUND command are operational after tracing a stop or wait instruction, and still in stop or wait mode. If system stop mode is entered (all bus masters are in stop mode) no BDM command is operational.

As soon as stop or wait mode is exited the CPU enters BDM active mode and the saved PC value points to the entry of the corresponding interrupt service routine.

In case the handshake feature is enabled the corresponding ACK pulse of the TRACE1 command is discarded when tracing a stop or wait instruction. Hence there is no ACK pulse when BDM active mode is entered as part of the TRACE1 command after CPU exited from stop or wait mode. All valid commands sent during CPU being in stop or wait mode or after CPU exited from stop or wait mode has an ACK pulse. The handshake feature becomes disabled only when system stop mode has been reached. Hence after a system stop mode the handshake feature must be enabled again by sending the ACK\_ENABLE command.

#### 4.30.4.11 Serial Communication Timeout

The host initiates a host-to-target serial transmission by generating a falling edge on the BKGD pin. If BKGD is kept low for more than 128 target clock cycles, the target understands a SYNC command was issued. In this case, the target keeps waiting for a rising edge on BKGD in order to answer the SYNC request pulse. If the rising edge is not detected, the target keeps waiting forever without any timeout limit.

Consider now the case where the host returns BKGD to logic one before 128 cycles. This is interpreted as a valid bit transmission, and not as a SYNC request. The target keeps waiting for another falling edge marking the start of a new bit. However, if a new falling edge is not detected by the target within 512 clock cycles since the last falling edge, a timeout occurs and the current command is discarded without affecting memory or the operating mode of the MCU. This is referred to as a soft reset.

If a read command is issued but the data is not retrieved within 512 serial clock cycles, a soft reset occurs causing the command to be disregarded. The data is not available for retrieval after the timeout has occurred. This is the expected behavior if the handshake protocol is not enabled. In order to allow the data to be retrieved even with a large clock frequency mismatch (between BDM and CPU) when the hardware handshake protocol is enabled, the timeout between a read command and the data retrieval is disabled. Therefore, the host could wait for more than 512 serial clock cycles and still be able to retrieve the data from an issued read command. However, once the handshake pulse (ACK pulse) is issued, the timeout feature is re-activated, meaning the target times out after 512 clock cycles. Therefore, the host needs to retrieve the data within a 512 serial clock cycles time frame after the ACK pulse had been issued. After this period, the read command is discarded and the data is no longer available for retrieval. Any negative edge in the BKGD pin after the timeout period is considered to be a new command or a SYNC request.

Note that whenever a partially issued command, or partially retrieved data, has occurred the timeout in the serial communication is active. This means if a time frame higher than 512 serial clock cycles is observed between two consecutive negative edges, and the command being issued or data being retrieved is not complete, a soft reset occurs causing the partially received command or data retrieved to be disregarded. The next negative edge in the BKGD pin, after a soft reset has occurred, is considered by the target as the start of a new BDM command, or the start of a SYNC request pulse.

### 4.31 S12S Debug (S12SDBGV1) Module

#### 4.31.1 Introduction

The S12SDBGV1 module provides an on-chip trace buffer with flexible triggering capability to allow non-intrusive debug of application software. The S12SDBGV1 module is optimized for S12SCPU debugging.

Typically the S12SDBGV1 module is used in conjunction with the S12SBDM module, whereby the user configures the S12SDBGV1 module for a debugging session over the BDM interface. Once configured the S12SDBGV1 module is armed and the device leaves BDM returning control to the user program, which is then monitored by the S12SDBGV1 module. Alternatively, the S12SDBGV1 module can be configured over a serial interface using SWI routines.

### 4.31.1.1 Glossary Of Terms

COF — Change Of Flow. Change in the program flow due to a conditional branch, indexed jump or interrupt.

BDM — Background Debug mode

S12SBDM — Background Debug module

WORD — 16 bit data entity

Data Line — 20 bit data entity

CPU — S12SCPU module

DBG — S12SDBG module

Tag — Tags can be attached to CPU opcodes as they enter the instruction pipe. If the tagged opcode reaches the execution stage a tag hit occurs.

### 4.31.1.2 Overview

The comparators monitor the bus activity of the CPU module. A match can initiate a state sequencer transition. On a transition to the Final State, bus tracing is triggered and/or a breakpoint can be generated. Independent of comparator matches a transition to Final State with associated tracing and breakpoint can be triggered immediately by writing to the TRIG control bit. The trace buffer is visible through a 2-byte window in the register address map and can be read out using standard 16-bit word reads. Tracing is disabled when the MCU system is secured.

### 4.31.1.3 Features

- Three comparators (A, B, and C)
  - Comparators A compares the full address bus and full 16-bit data bus
  - Comparator A features a data bus mask register
  - Comparators B and C compare the full address bus only
  - Each comparator features selection of read or write access cycles
  - Comparator B allows selection of byte or word access cycles
  - Comparator matches can initiate state sequencer transitions
- Three comparator modes
  - Simple address/data comparator match mode
  - Inside address range mode,  $\text{Addmin} \leq \text{Address} \leq \text{Addmax}$
  - Outside address range match mode,  $\text{Address} < \text{Addmin}$  or  $\text{Address} > \text{Addmax}$
- Two types of matches
  - Tagged — This matches just before a specific instruction begins execution
  - Force — This is valid on the first instruction boundary after a match occurs
- Two types of breakpoints
  - CPU breakpoint entering BDM on breakpoint (BDM)
  - CPU breakpoint executing SWI on breakpoint (SWI)
- Trigger mode independent of comparators
  - TRIG Immediate software trigger
- Four trace modes
  - Normal: change of flow (COF) PC information is stored (see [Section 4.31.4.5.3, "Normal Mode"](#)) for change of flow definition.
  - Loop1: same as Normal but inhibits consecutive duplicate source address entries
  - Detail: address and data for all cycles except free cycles and opcode fetches are stored
  - Pure PC: All program counter addresses are stored
- 4-stage state sequencer for trace buffer control
  - Tracing session trigger linked to Final State of state sequencer
  - Begin and End alignment of tracing to trigger

### 4.31.1.4 Modes of Operation

The DBG module can be used in all MCU functional modes. During BDM hardware accesses and whilst the BDM module is active, CPU monitoring is disabled. When the CPU enters active BDM Mode through a BACKGROUND command, the DBG module, if already armed, remains armed. The DBG module tracing is disabled if the MCU is secure, however, breakpoints can still be generated

**Table 261. Mode Dependent Restriction Summary**

BDM Enable	BDM Active	MCU Secure	Comparator Matches Enabled	Breakpoints Possible	Tagging Possible	Tracing Possible	
x	x	1	Yes	Yes	Yes	No	
0	0	0	Yes	Only SWI	Yes	Yes	
0	1	0	Active BDM not possible when not enabled				
1	0	0	Yes	Yes	Yes	Yes	
1	1	0	No	No	No	No	

#### 4.31.1.5 Block Diagram

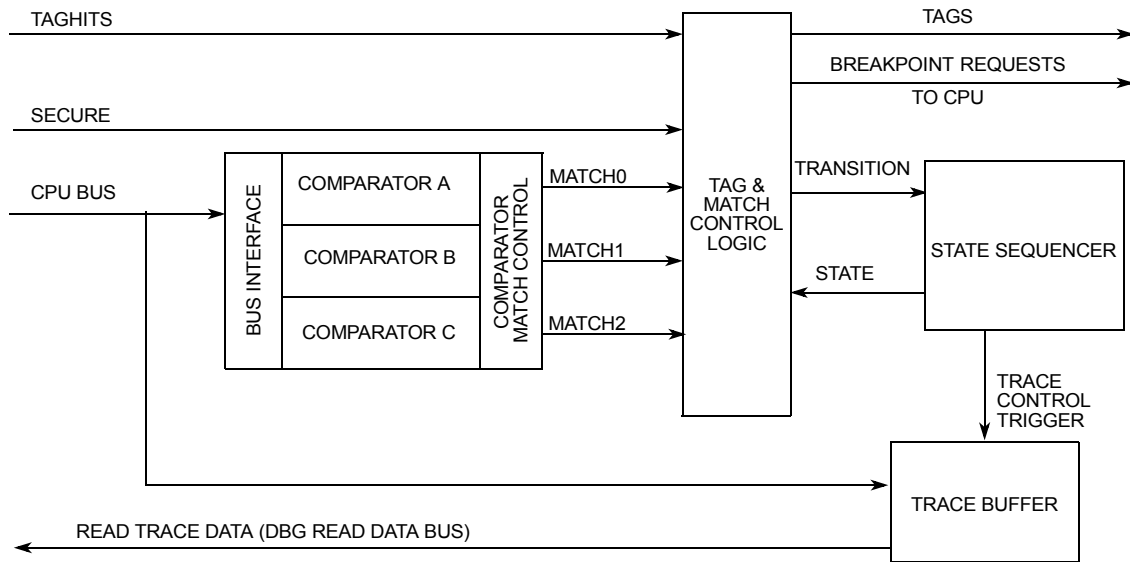
**Figure 67. Debug Module Block Diagram**

#### 4.31.2 External Signal Description

There are no external signals associated with this module.

#### 4.31.3 Memory Map and Registers

##### 4.31.3.1 Module Memory Map

A summary of the registers associated with the DBG sub-block is shown in [Table 262](#). Detailed descriptions of the registers and bits are given in the following subsections.

**Table 262. Quick Reference to DBG Registers**

Address	Name		Bit 7	6	5	4	3	2	1	Bit 0
0x0020	DBG_C1	R	ARM	0	0	BDM	DBGBRK	0	COMRV	
		W		TRIG						
0x0021	DBGSR	R	TBF <sup>(181)</sup>	0	0	0	0	SSF2	SSF1	SSF0
		W								

**Table 262. Quick Reference to DBG Registers (continued)**

Address	Name		Bit 7	6	5	4	3	2	1	Bit 0
0x0022	DBGTCR	R	0	TSOURCE	0	0	TRCMOD		0	TALIGN
		W								
0x0023	DBGC2	R	0	0	0	0	0	0	ABCM	
		W								
0x0024	DBGTBH	R	Bit 15	Bit 14	Bit 13	Bit 12	Bit 11	Bit 10	Bit 9	Bit 8
		W								
0x0025	DBGTBL	R	Bit 7	Bit 6	Bit 5	Bit 4	Bit 3	Bit 2	Bit 1	Bit 0
		W								
0x0026	DBGCNT	R	TBF	0	CNT					
		W								
0x0027	DBGSCRX	R	0	0	0	0	0	SC2	SC1	SC0
		W								
0x0027	DBGMFR	R	0	0	0	0	0	MC2	MC1	MC0
		W								
0x0028 <sup>(182)</sup>	DBGACTL	R	0	NDB	TAG	BRK	RW	RWE	0	COMPE
		W								
0x0028 <sup>(183)</sup>	DBGBCTL	R	SZE	SZ	TAG	BRK	RW	RWE	0	COMPE
		W								
0x0028 <sup>(184)</sup>	DBGCCTL	R	0	0	TAG	BRK	RW	RWE	0	COMPE
		W								
0x0029	DBGXAH	R	0	0	0	0	0	0	Bit 17	Bit 16
		W								
0x002A	DBGXAM	R	Bit 15	14	13	12	11	10	9	Bit 8
		W								
0x002B	DBGXAL	R	Bit 7	6	5	4	3	2	1	Bit 0
		W								
0x002C	DBGADH	R	Bit 15	14	13	12	11	10	9	Bit 8
		W								
0x002D	DBGADL	R	Bit 7	6	5	4	3	2	1	Bit 0
		W								
0x002E	DBGADHM	R	Bit 15	14	13	12	11	10	9	Bit 8
		W								
0x002F	DBGADLM	R	Bit 7	6	5	4	3	2	1	Bit 0
		W								

**Note:**

- 181. This bit is visible at DBGCNT[7] and DBGSR[7]
- 182. This represents the contents if the Comparator A control register is blended into this address.
- 183. This represents the contents if the Comparator B control register is blended into this address.
- 184. This represents the contents if the Comparator C control register is blended into this address.

### 4.31.3.2 Register Descriptions

This section consists of the DBG control and trace buffer register descriptions in address order. Each comparator has a bank of registers visible through an 8-byte window between 0x0028 and 0x002F in the DBG module register address map. When ARM is set in DBGC1, the only bits in the DBG module registers which can be written are ARM, TRIG, and COMRV[1:0]

#### 4.31.3.2.1 Debug Control Register 1 (DBGC1)

##### NOTE

When disarming the DBG by clearing ARM with software, the contents of bits[4:3] are not affected by the write, since up until the write operation, ARM = 1 preventing these bits from being written. These bits must be cleared using a second write if required.

**Table 263. Debug Control Register (DBGC1)**

Address: 0x0020

	7	6	5	4	3	2	1	0
R	ARM	0	0	BDM	DBGBRK	0	COMRV	
W		TRIG						
Reset	0	0	0	0	0	0	0	0

Read: Anytime

Write: Bits 7, 1, 0 anytime

Bit 6 can be written anytime but always reads back as 0.

Bits 4:3 anytime DBG is not armed.

**Table 264. DBGC1 Field Descriptions**

Field	Description
7 ARM	<b>Arm Bit</b> — The ARM bit controls whether the DBG module is armed. This bit can be set and cleared by user software and is automatically cleared on completion of a tracing session, or if a breakpoint is generated with tracing not enabled. On setting this bit the state sequencer enters State1. 0 Debugger disarmed 1 Debugger armed
6 TRIG	<b>Immediate Trigger Request Bit</b> — This bit when written to 1 requests an immediate trigger independent of comparator status. When tracing is complete a forced breakpoint may be generated depending upon DBGBRK and BDM bit settings. This bit always reads back a 0. Writing a 0 to this bit has no effect. If the DBGTCR_TSOURCE bit is clear no tracing is carried out. If tracing has already commenced using BEGIN trigger alignment, it continues until the end of the tracing session as defined by the TALIGN bit, thus TRIG has no affect. In secure mode tracing is disabled and writing to this bit cannot initiate a tracing session. 0 Do not trigger until the state sequencer enters the Final State. 1 Enter Final State immediately and issue forced breakpoint request on tracing completion
4 BDM	<b>Background Debug Mode Enable</b> — This bit determines if an S12X breakpoint causes the system to enter Background Debug Mode (BDM) or initiate a Software Interrupt (SWI). If this bit is set but the BDM is not enabled by the ENBDM bit in the BDM module, then breakpoints default to SWI. 0 Breakpoint to Software Interrupt if BDM inactive. Otherwise no breakpoint. 1 Breakpoint to BDM, if BDM enabled. Otherwise breakpoint to SWI
3 DBGBRK	<b>S12SDBGV1 Breakpoint Enable Bit</b> — The DBGBRK bit controls whether the debugger requests a breakpoint on reaching the state sequencer Final State. If tracing is enabled, the breakpoint is generated on completion of the tracing session. If tracing is not enabled, the breakpoint is generated immediately. 0 No Breakpoint generated 1 Breakpoint generated
1-0 COMRV	<b>Comparator Register Visibility Bits</b> — These bits determine which bank of comparator register is visible in the 8-byte window of the S12SDBG module address map, located between 0x0028 to 0x002F. Furthermore, these bits determine which register is visible at the address 0x0027. See <a href="#">Table 265</a> .

**Table 265. COMRV Encoding**

COMRV	Visible Comparator	Visible Register at 0x0027
00	Comparator A	DBGSCR1
01	Comparator B	DBGSCR2
10	Comparator C	DBGSCR3
11	None	DBGMFR

**4.31.3.2.2 Debug Status Register (DBGSR)**

**Table 266. Debug Status Register (DBGSR)**

Address: 0x0021

	7	6	5	4	3	2	1	0
R	TBF	0	0	0	0	SSF2	SSF1	SSF0
W								
Reset	—	0	0	0	0	0	0	0
POR	0	0	0	0	0	0	0	0

Read: Anytime  
Write: Never

**Table 267. DBGSR Field Descriptions**

Field	Description
7 TBF	<b>Trace Buffer Full</b> — The TBF bit indicates the trace buffer has stored 64 or more lines of data since it was last armed. If this bit is set, then all 64 lines are valid data, regardless of the value of DBGCNT bits. The TBF bit is cleared when ARM in DBGCR1 is written to a one. The TBF is cleared by the power on reset initialization. Other system generated resets have no affect on this bit. This bit is also visible at DBGCNT[7].
2–0 SSF[2:0]	<b>State Sequencer Flag Bits</b> — The SSF bits indicate in which state the State Sequencer is in currently. During a debug session on each transition to a new state these bits are updated. If the debug session is ended by software clearing the ARM bit, then these bits retain their value to reflect the last state of the state sequencer before disarming. If a debug session is ended by an internal event, then the state sequencer returns to state 0 and these bits are cleared to indicate state0 was entered during the session. On arming the module the state sequencer enters state1 and these bits are forced to SSF[2:0] = 001. See <a href="#">Table 268</a> .

**Table 268. SSF[2:0] — State Sequence Flag Bit Encoding**

SSF[2:0]	Current State
000	State0 (disarmed)
001	State1
010	State2
011	State3
100	Final State
101,110,111	Reserved

### 4.31.3.2.3 Debug Trace Control Register (DBGTCR)

**Table 269. Debug Trace Control Register (DBGTCR)**

Address: 0x0022

	7	6	5	4	3	2	1	0
R	0	TSOURCE	0	0	TRCMOD		0	TALIGN
W								
Reset	0	0	0	0	0	0	0	0

Read: Anytime

Write: Bit 6 only when DBG is neither secure nor armed. Bits 3,2,0 anytime the module is disarmed.

**Table 270. DBGTCR Field Descriptions**

Field	Description
6 TSOURCE	<b>Trace Source Control Bit</b> — The TSOURCE bit enables a tracing session given a trigger condition. If the MCU system is secured, this bit cannot be set and tracing is inhibited. This bit must be set to read the trace buffer. 0 Debug session without tracing requested 1 Debug session with tracing requested
3–2 TRCMOD	<b>Trace Mode Bits</b> — See Section 4.31.4.5.2, "Trace Modes" for detailed Trace Mode descriptions. In Normal mode, change of flow information is stored. In Loop1 mode, change of flow information is stored but redundant entries into trace memory are inhibited. In Detail mode, address and data for all memory and register accesses is stored. In Pure PC mode the program counter value for each instruction executed is stored. See Table 271.
0 TALIGN	<b>Trigger Align Bit</b> — This bit controls whether the trigger is aligned to the beginning or end of a tracing session. 0 Trigger at end of stored data 1 Trigger before storing data

**Table 271. TRCMOD Trace Mode Bit Encoding**

TRCMOD	Description
00	Normal
01	Loop1
10	Detail
11	Pure PC

### 4.31.3.2.4 Debug Control Register2 (DBGCR2)

**Table 272. Debug Control Register2 (DBGCR2)**

Address: 0x0023

	7	6	5	4	3	2	1	0
R	0	0	0	0	0	0	ABCM	
W								
Reset	0	0	0	0	0	0	0	0

Read: Anytime

Write: Anytime the module is disarmed.

This register configures the comparators for range matching.

**Table 273. DBG2 Field Descriptions**

Field	Description
1–0 ABCM[1:0]	<b>A and B Comparator Match Control</b> — These bits determine the A and B comparator match mapping as described in <a href="#">Table 274</a> .

**Table 274. ABCM Encoding**

ABCM	Description
00	Match0 mapped to comparator A match: Match1 mapped to comparator B match.
01	Match 0 mapped to comparator A/B inside range: Match1 disabled.
10	Match 0 mapped to comparator A/B outside range: Match1 disabled.
11	Reserved <sup>(185)</sup>

Note:

185. Currently defaults to Comparator A, Comparator B disabled.

**4.31.3.2.5 Debug Trace Buffer Register (DBGTBH:DBGTBL)**

**Table 275. Debug Trace Buffer Register (DBGTB)**

Address: 0x0024, 0x0025

	15	14	13	12	11	10	9	8	7	6	5	4	3	2	1	0
R	Bit 15	Bit 14	Bit 13	Bit 12	Bit 11	Bit 10	Bit 9	Bit 8	Bit 7	Bit 6	Bit 5	Bit 4	Bit 3	Bit 2	Bit 1	Bit 0
W																
POR	X	X	X	X	X	X	X	X	X	X	X	X	X	X	X	X
Other Resets	—	—	—	—	—	—	—	—	—	—	—	—	—	—	—	—

Read: Only when unlocked AND unsecured AND not armed AND TSOURCE set.

Write: Aligned word writes when disarmed unlock the trace buffer for reading but do not affect trace buffer contents.

**Table 276. DBGTB Field Descriptions**

Field	Description
15–0 Bit[15:0]	<b>Trace Buffer Data Bits</b> — The Trace Buffer Register is a window through which the 20-bit wide data lines of the Trace Buffer may be read 16 bits at a time. Each valid read of DBGTB increments an internal trace buffer pointer which points to the next address to be read. When the ARM bit is written to 1, the trace buffer is locked to prevent reading. The trace buffer can only be unlocked for reading by writing to DBGTB with an aligned word write when the module is disarmed. The DBGTB register can be read only as an aligned word, any byte reads or misaligned access of these registers returns 0 and does not cause the trace buffer pointer to increment to the next trace buffer address. The same is true for word reads while the debugger is armed and for reads with the TSOURCE bit clear. The POR state is undefined. Other resets do not affect the trace buffer contents.

### 4.31.3.2.6 Debug Count Register (DBGCNT)

**Table 277. Debug Count Register (DBGCNT)**

Address: 0x0026

	7	6	5	4	3	2	1	0
R	TBF	0	CNT					
W								
Reset	—	—	—	—	—	—	—	—
POR	0	0	0	0	0	0	0	0

Read: Anytime

Write: Never

**Table 278. DBGCNT Field Descriptions**

Field	Description
7 TBF	<b>Trace Buffer Full</b> — The TBF bit indicates the trace buffer has stored 64 or more lines of data since it was last armed. If this bit is set, then all 64 lines are valid data, regardless of the value of DBGCNT bits. The TBF bit is cleared when ARM in DBG1 is written to a one. The TBF is cleared by the power on reset initialization. Other system generated resets have no affect on this bit. This bit is also visible at DBGSR[7]
5–0 CNT[5:0]	<b>Count Value</b> — The CNT bits indicate the number of valid data 20-bit data lines stored in the Trace Buffer. Table 279 shows the correlation between the CNT bits and the number of valid data lines in the Trace Buffer. When the CNT rolls over to zero, the TBF bit in DBGSR is set and incrementing of CNT continues in end-trigger mode. The DBGCNT register is cleared when ARM in DBG1 is written to a one. The DBGCNT register is cleared by power-on-reset initialization, but is not cleared by other system resets. Thus, should a reset occur during a debug session, the DBGCNT register still indicates after the reset, the number of valid trace buffer entries stored before the reset occurred. The DBGCNT register is not decremented when reading from the trace buffer.

**Table 279. CNT Decoding Table**

TBF	CNT[5:0]	Description
0	000000	No data valid
0	000001	1 line valid
	000010	2 lines valid
	000100	4 lines valid
	000110	6 lines valid
	... 111111	... 63 lines valid
1	000000	64 lines valid; if using Begin trigger alignment, ARM bit is cleared and the tracing session ends.
1	000001	64 lines valid, oldest data has been overwritten by most recent data
	...	
	... 111110	

### 4.31.3.2.7 Debug State Control Registers

There is a dedicated control register for each of the state sequencer states 1 to 3 which determines if transitions from that state are allowed, depending upon comparator matches or tag hits, and defines the next state for the state sequencer following a match. The three debug state control registers are located at the same address in the register address map (0x0027). Each register can be accessed using the COMRV bits in DBG1 to blend in the required register. The COMRV = 11 value blends in the match flag register (DBGMFR).

**Table 280. State Control Register Access Encoding**

COMRV	Visible State Control Register
00	DBGSCR1
01	DBGSCR2
10	DBGSCR3
11	DBGMFR

**4.31.3.2.7.1 Debug State Control Register 1 (DBGSCR1)**

**Table 281. Debug State Control Register 1 (DBGSCR1)**

Address: 0x0027

	7	6	5	4	3	2	1	0
R	0	0	0	0	0	SC2	SC1	SC0
W								
Reset	0	0	0	0	0	0	0	0

Read: If COMRV[1:0] = 00

Write: If COMRV[1:0] = 00 and DBG is not armed.

This register is visible at 0x0027 only with COMRV[1:0] = 00. The state control register 1 selects the targeted next state whilst in State1. The matches refer to the match channels of the comparator match control logic as depicted in Figure 67 and described in Section 4.31.3.2.8.1, “Debug Comparator Control Register (DBGXCTL)”. Comparators must be enabled by setting the comparator enable bit in the associated DBGXCTL control register.

**Table 282. DBGSCR1 Field Descriptions**

Field	Description
2–0 SC[2:0]	These bits select the targeted next state whilst in State1, based upon the match event.

**Table 283. State1 Sequencer Next State Selection**

SC[2:0]	Description
000	Any match to Final State
001	Match1 to State3
010	Match2 to State2
011	Match1 to State2
100	Match0 to State2..... Match1 to State3
101	Match1 to State3..... Match0 Final State
110	Match0 to State2..... Match2 to State3
111	Either Match0 or Match1 to State2..... Match2 has no effect

The priorities described in Table 314 dictate in the case of simultaneous matches, the match on the lower channel number (0,1,2) has priority. The SC[2:0] encoding ensures a match leading to final state has priority over all other matches.

### 4.31.3.2.7.2 Debug State Control Register 2 (DBGSCR2)

**Table 284. Debug State Control Register 2 (DBGSCR2)**

Address: 0x0027

	7	6	5	4	3	2	1	0
R	0	0	0	0	0	SC2	SC1	SC0
W								
Reset	0	0	0	0	0	0	0	0

Read: If COMRV[1:0] = 01

Write: If COMRV[1:0] = 01 and DBG is not armed.

This register is visible at 0x0027 only with COMRV[1:0] = 01. The state control register 2 selects the targeted next state whilst in State2. The matches refer to the match channels of the comparator match control logic as depicted in [Figure 67](#) and described in [Section 4.31.3.2.8.1, "Debug Comparator Control Register \(DBGXCTL\)"](#). Comparators must be enabled by setting the comparator enable bit in the associated DBGXCTL control register.

**Table 285. DBGSCR2 Field Descriptions**

Field	Description
2-0 SC[2:0]	These bits select the targeted next state whilst in State2, based upon the match event.

**Table 286. State2 —Sequencer Next State Selection**

SC[2:0]	Description
000	Match0 to State1..... Match2 to State3.
001	Match1 to State3
010	Match2 to State3
011	Match1 to State3..... Match0 Final State
100	Match1 to State1..... Match2 to State3
101	Match2 Final State
110	Match2 to State1..... Match0 to Final State
111	Match2 has no affect, all other matches (M0,M1) to Final State

The priorities described in [Table 314](#) dictate in the case of simultaneous matches, the match on the lower channel number (0,1,2) has priority. The SC[2:0] encoding ensures a match leading to final state has priority over all other matches

### 4.31.3.2.7.3 Debug State Control Register 3 (DBGSCR3)

**Table 287. Debug State Control Register 3 (DBGSCR3)**

Address: 0x0027

	7	6	5	4	3	2	1	0
R	0	0	0	0	0	SC2	SC1	SC0
W								
Reset	0	0	0	0	0	0	0	0

Read: If COMRV[1:0] = 10

Write: If COMRV[1:0] = 10 and DBG is not armed.

This register is visible at 0x0027 only with COMRV[1:0] = 10. The state control register three selects the targeted next state whilst in State3. The matches refer to the match channels of the comparator match control logic as depicted in Figure 67 and described in Section 4.31.3.2.8.1, "Debug Comparator Control Register (DBGXCTL)". Comparators must be enabled by setting the comparator enable bit in the associated DBGXCTL control register.

**Table 288. DBGSCR3 Field Descriptions**

Field	Description
2-0 SC[2:0]	These bits select the targeted next state whilst in State3, based upon the match event.

**Table 289. State3 — Sequencer Next State Selection**

SC[2:0]	Description
000	Match0 to State1
001	Match2 to State2..... Match1 to Final State
010	Match0 to Final State.....Match1 to State1
011	Match1 to Final State..... Match2 to State1
100	Match1 to State2
101	Match1 to Final State
110	Match2 to State2..... Match0 to Final State
111	Match0 to Final State

The priorities described in Table 314 dictate in the case of simultaneous matches, the match on the lower channel number (0,1,2) has priority. The SC[2:0] encoding ensures a match leading to final state has priority over all other matches.

**4.31.3.2.7.4 Debug Match Flag Register (DBGMFR)**

**Table 290. Debug Match Flag Register (DBGMFR)**

Address: 0x0027

	7	6	5	4	3	2	1	0
R	0	0	0	0	0	MC2	MC1	MC0
W								
Reset	0	0	0	0	0	0	0	0

Read: If COMRV[1:0] = 11

Write: Never

DBGMFR is visible at 0x0027 only with COMRV[1:0] = 11. It features 3 flag bits each mapped directly to a channel. Should a match occur on the channel during the debug session, then the corresponding flag is set and remains set until the next time the module is armed by writing to the ARM bit. Thus the contents are retained after a debug session for evaluation purposes. These flags cannot be cleared by software, they are cleared only when arming the module. A set flag does not inhibit the setting of other flags. Once a flag is set, further comparator matches on the same channel in the same session have no affect on that flag.

**4.31.3.2.8 Comparator Register Descriptions**

Each comparator has a bank of registers visible through an 8-byte window in the DBG module register address map. Comparator A consists of 8 register bytes (3 address bus compare registers, two data bus compare registers, two data bus mask registers and a control register). Comparator B consists of four register bytes (three address bus compare registers and a control register). Comparator C consists of four register bytes (three address bus compare registers and a control register).

Each set of comparator registers can be accessed using the COMRV bits in the DBGC1 register. Unimplemented registers (e.g. Comparator B data bus and data bus masking) read as zero and cannot be written. The control register for comparator B differs from those of comparators A and C.

**Table 291. Comparator Register Layout**

0x0028	CONTROL	Read/Write	Comparators A,B and C
0x0029	ADDRESS HIGH	Read/Write	Comparators A,B and C
0x002A	ADDRESS MEDIUM	Read/Write	Comparators A,B and C
0x002B	ADDRESS LOW	Read/Write	Comparators A,B and C
0x002C	DATA HIGH COMPARATOR	Read/Write	Comparator A only
0x002D	DATA LOW COMPARATOR	Read/Write	Comparator A only
0x002E	DATA HIGH MASK	Read/Write	Comparator A only
0x002F	DATA LOW MASK	Read/Write	Comparator A only

#### 4.31.3.2.8.1 Debug Comparator Control Register (DBGXCTL)

The contents of this register bits 7 and 6 differ depending upon which comparator registers are visible in the 8-byte window of the DBG module register address map.

**Table 292. Debug Comparator Control Register DBGACTL (Comparator A)**

Address: 0x0028

	7	6	5	4	3	2	1	0
R	0	NDB	TAG	BRK	RW	RWE	0	COMPE
W								
Reset	0	0	0	0	0	0	0	0

**Table 293. Debug Comparator Control Register DBGBCTL (Comparator B)**

Address: 0x0028

	7	6	5	4	3	2	1	0
R	SZE	SZ	TAG	BRK	RW	RWE	0	COMPE
W								
Reset	0	0	0	0	0	0	0	0

**Table 294. Debug Comparator Control Register DBGCCCTL (Comparator C)**

Address: 0x0028

	7	6	5	4	3	2	1	0
R	0	0	TAG	BRK	RW	RWE	0	COMPE
W								
Reset	0	0	0	0	0	0	0	0

Read: DBGACTL if COMRV[1:0] = 00

DBGBCTL if COMRV[1:0] = 01

DBGCCCTL if COMRV[1:0] = 10

Write: DBGACTL if COMRV[1:0] = 00 and DBG not armed  
 DBGBCTL if COMRV[1:0] = 01 and DBG not armed  
 DBGCCCTL if COMRV[1:0] = 10 and DBG not armed

**Table 295. DBGXCTL Field Descriptions**

Field	Description
7 SZE (Comparator B)	<b>Size Comparator Enable Bit</b> — The SZE bit controls whether access size comparison is enabled for the associated comparator. This bit is ignored if the TAG bit in the same register is set. 0 Word/Byte access size is not used in comparison 1 Word/Byte access size is used in comparison
6 NDB (Comparator A)	<b>Not Data Bus</b> — The NDB bit controls whether the match occurs when the data bus matches the comparator register value or when the data bus differs from the register value. This bit is ignored if the TAG bit in the same register is set. This bit is only available for comparator A. 0 Match on data bus equivalence to comparator register contents 1 Match on data bus difference to comparator register contents
6 SZ (Comparator B)	<b>Size Comparator Value Bit</b> — The SZ bit selects either word or byte access size in comparison for the associated comparator. This bit is ignored if the SZE bit is cleared or if the TAG bit in the same register is set. This bit is only featured in comparator B. 0 Word access size is compared 1 Byte access size is compared
5 TAG	<b>Tag Select</b> — This bit controls whether the comparator match has immediate effect, causing an immediate state sequencer transition or tag the opcode at the matched address. Tagged opcodes trigger only if they reach the execution stage of the instruction queue. 0 Allow state sequencer transition immediately on match 1 On match, tag the opcode. If the opcode is about to be executed allow a state sequencer transition
4 BRK	<b>Break</b> — This bit controls whether a comparator match terminates a debug session immediately, independent of state sequencer state. To generate an immediate breakpoint the module breakpoints must be enabled using the DBG1 bit DBGBRK. 0 The debug session termination is dependent upon the state sequencer and trigger conditions. 1 A match on this channel terminates the debug session immediately; breakpoints if active are generated, tracing, if active, is terminated and the module disarmed.
3 RW	<b>Read/Write Comparator Value Bit</b> — The RW bit controls whether read or write is used in compare for the associated comparator. The RW bit is not used if RWE = 0. This bit is ignored if the TAG bit in the same register is set. 0 Write cycle is matched 1 Read cycle is matched
2 RWE	<b>Read/Write Enable Bit</b> — The RWE bit controls whether read or write comparison is enabled for the associated comparator. This bit is ignored if the TAG bit in the same register is set 0 Read/Write is not used in comparison 1 Read/Write is used in comparison
0 COMPE	Determines if comparator is enabled 0 The comparator is not enabled 1 The comparator is enabled

Table 296 shows the effect for RWE and RW on the comparison conditions. These bits are ignored if the corresponding TAG bit is set since the match occurs based on the tagged opcode reaching the execution stage of the instruction queue.

**Table 296. Read or Write Comparison Logic Table**

RWE Bit	RW Bit	RW Signal	Comment
0	x	0	RW not used in comparison
0	x	1	RW not used in comparison
1	0	0	Write data bus
1	0	1	No match
1	1	0	No match
1	1	1	Read data bus

### 4.31.3.2.8.2 Debug Comparator Address High Register (DBGXAH)

**Table 297. Debug Comparator Address High Register (DBGXAH)**

Address: 0x0029

	7	6	5	4	3	2	1	0
R	0	0	0	0	0	0	Bit 17	Bit 16
W								
Reset	0	0	0	0	0	0	0	0

The DBG\_C1\_COMRV bits determine which comparator address registers are visible in the 8-byte window from 0x0028 to 0x002F.

**Table 298. Comparator Address Register Visibility**

COMRV	Visible Comparator
00	DBGAAH, DBGAAM, DBGAAL
01	DBGBAH, DBGBAM, DBGBAL
10	DBGCAH, DBGCAM, DBGCAL
11	None

Read: Anytime. See [Table 299](#) for visible register encoding.

Write: If DBG not armed. See [Table 299](#) for visible register encoding.

**Table 299. DBGXAH Field Descriptions**

Field	Description
1–0 Bit[17:16]	<b>Comparator Address High Compare Bits</b> — The Comparator address high compare bits control whether the selected comparator compares the address bus bits [17:16] to a logic one or logic zero. 0 Compare corresponding address bit to a logic zero 1 Compare corresponding address bit to a logic one

### 4.31.3.2.8.3 Debug Comparator Address Mid Register (DBGXAM)

**Table 300. Debug Comparator Address Mid Register (DBGXAM)**

Address: 0x002A

	7	6	5	4	3	2	1	0
R	Bit 15	Bit 14	Bit 13	Bit 12	Bit 11	Bit 10	Bit 9	Bit 8
W								
Reset	0	0	0	0	0	0	0	0

Read: Anytime. See [Table 300](#) for visible register encoding.

Write: If DBG not armed. See [Table 300](#) for visible register encoding.

**Table 301. DBGXAM Field Descriptions**

Field	Description
7–0 Bit[15:8]	<b>Comparator Address Mid Compare Bits</b> — The Comparator address mid compare bits control whether the selected comparator compares the address bus bits [15:8] to a logic one or logic zero. 0 Compare corresponding address bit to a logic zero 1 Compare corresponding address bit to a logic one

**4.31.3.2.8.4 Debug Comparator Address Low Register (DBGXAL)**

**Table 302. Debug Comparator Address Low Register (DBGXAL)**

Address: 0x002B

	7	6	5	4	3	2	1	0
R	Bit 7	Bit 6	Bit 5	Bit 4	Bit 3	Bit 2	Bit 1	Bit 0
W								
Reset	0	0	0	0	0	0	0	0

Read: Anytime. See [Table 303](#) for visible register encoding.  
 Write: If DBG not armed. See [Table 303](#) for visible register encoding.

**Table 303. DBGXAL Field Descriptions**

Field	Description
7–0 Bits[7:0]	<b>Comparator Address Low Compare Bits</b> — The Comparator address low compare bits control whether the selected comparator compares the address bus bits [7:0] to a logic one or logic zero. 0 Compare corresponding address bit to a logic zero 1 Compare corresponding address bit to a logic one

**4.31.3.2.8.5 Debug Comparator Data High Register (DBGADH)**

**Table 304. Debug Comparator Data High Register (DBGADH)**

Address: 0x002C

	7	6	5	4	3	2	1	0
R	Bit 15	Bit 14	Bit 13	Bit 12	Bit 11	Bit 10	Bit 9	Bit 8
W								
Reset	0	0	0	0	0	0	0	0

Read: If COMRV[1:0] = 00  
 Write: If COMRV[1:0] = 00 and DBG not armed.

**Table 305. DBGADH Field Descriptions**

Field	Description
7–0 Bits[15:8]	<b>Comparator Data High Compare Bits</b> — The Comparator data high compare bits control whether the selected comparator compares the data bus bits [15:8] to a logic one or logic zero. The comparator data compare bits are only used in comparison if the corresponding data mask bit is logic 1. This register is available only for comparator A. Data bus comparisons are only performed if the TAG bit in DBGACTL is clear. 0 Compare corresponding data bit to a logic zero 1 Compare corresponding data bit to a logic one

### 4.31.3.2.8.6 Debug Comparator Data Low Register (DBGADL)

**Table 306. Debug Comparator Data Low Register (DBGADL)**

Address: 0x002D

	7	6	5	4	3	2	1	0
R	Bit 7	Bit 6	Bit 5	Bit 4	Bit 3	Bit 2	Bit 1	Bit 0
W								
Reset	0	0	0	0	0	0	0	0

Read: If COMRV[1:0] = 00

Write: If COMRV[1:0] = 00 and DBG not armed.

**Table 307. DBGADL Field Descriptions**

Field	Description
7–0 Bits[7:0]	<b>Comparator Data Low Compare Bits</b> — The Comparator data low compare bits control whether the selected comparator compares the data bus bits [7:0] to a logic one or logic zero. The comparator data compare bits are only used in comparison if the corresponding data mask bit is logic 1. This register is available only for comparator A. Data bus comparisons are only performed if the TAG bit in DBGACTL is clear 0 Compare corresponding data bit to a logic zero 1 Compare corresponding data bit to a logic one

### 4.31.3.2.8.7 Debug Comparator Data High Mask Register (DBGADHM)

**Table 308. Debug Comparator Data High Mask Register (DBGADHM)**

Address: 0x002E

	7	6	5	4	3	2	1	0
R	Bit 15	Bit 14	Bit 13	Bit 12	Bit 11	Bit 10	Bit 9	Bit 8
W								
Reset	0	0	0	0	0	0	0	0

Read: If COMRV[1:0] = 00

Write: If COMRV[1:0] = 00 and DBG not armed.

**Table 309. DBGADHM Field Descriptions**

Field	Description
7–0 Bits[15:8]	<b>Comparator Data High Mask Bits</b> — The Comparator data high mask bits control whether the selected comparator compares the data bus bits [15:8] to the corresponding comparator data compare bits. Data bus comparisons are only performed if the TAG bit in DBGACTL is clear 0 Do not compare corresponding data bit. Any value of corresponding data bit allows match. 1 Compare corresponding data bit

**4.31.3.2.8.8 Debug Comparator Data Low Mask Register (DBGADLM)**

**Table 310. Debug Comparator Data Low Mask Register (DBGADLM)**

Address: 0x002F

	7	6	5	4	3	2	1	0
R	Bit 7	Bit 6	Bit 5	Bit 4	Bit 3	Bit 2	Bit 1	Bit 0
W								
Reset	0	0	0	0	0	0	0	0

Read: If COMRV[1:0] = 00

Write: If COMRV[1:0] = 00 and DBG not armed.

**Table 311. DBGADLM Field Descriptions**

Field	Description
7-0 Bits[7:0]	<p><b>Comparator Data Low Mask Bits</b> — The Comparator data low mask bits control whether the selected comparator compares the data bus bits [7:0] to the corresponding comparator data compare bits. Data bus comparisons are only performed if the TAG bit in DBGACTL is clear</p> <p>0 Do not compare corresponding data bit. Any value of corresponding data bit allows match</p> <p>1 Compare corresponding data bit</p>

**4.31.4 Functional Description**

This section provides a complete functional description of the DBG module. If the part is in secure mode, the DBG module can generate breakpoints, but tracing is not possible.

**4.31.4.1 S12SDBGV1 Operation**

Arming the DBG module by setting ARM in DBGC1 allows triggering the state sequencer, storing of data in the trace buffer, and generation of breakpoints to the CPU. The DBG module is made up of four main blocks, the comparators, control logic, the state sequencer, and the trace buffer.

The comparators monitor the bus activity of the CPU. All comparators can be configured to monitor address bus activity. Comparator A can also be configured to monitor databus activity and mask out individual data bus bits during a compare. Comparators can be configured to use R/W and word/byte access qualification in the comparison. A match with a comparator register value can initiate a state sequencer transition to another state (see [Figure 69](#)). Either forced or tagged matches are possible. Using a forced match, a state sequencer transition can occur immediately on a successful match of system busses and comparator registers. Whilst tagging, at a comparator match, the instruction opcode is tagged and only if the instruction reaches the execution stage of the instruction queue, can a state sequencer transition occur. In the case of a transition to Final State, bus tracing is triggered and/or a breakpoint can be generated.

A state sequencer transition to Final State (with associated breakpoint, if enabled) can be initiated by writing to the TRIG bit in the DBGC1 control register. The trace buffer is visible through a 2-byte window in the register address map, and must be read out using standard 16-bit word reads.

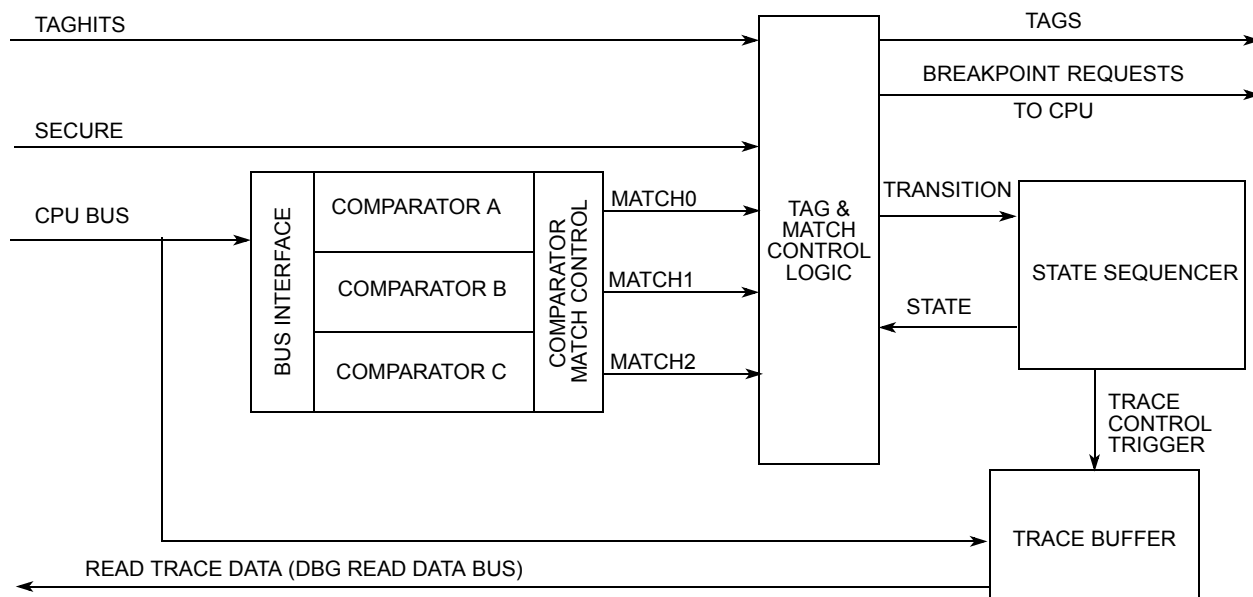

Figure 68. DBG Overview

#### 4.31.4.2 Comparator Modes

The DBG contains three comparators, A, B, and C. Each comparator compares the system address bus with the address stored in DBGXAH, DBGXAM, and DBGXAL. Furthermore, comparator A also compares the data buses to the data stored in DBGADH and DBGADL, and allows masking of individual data bus bits.

All comparators are disabled in BDM and during BDM accesses.

The comparator match control logic (see [Figure 68](#)) configures comparators to monitor the buses for an exact address or an address range, whereby either an access inside or outside the specified range generates a match condition. The comparator configuration is controlled by the control register contents and the range control by the DBGC2 contents.

A match can initiate a transition to another state sequencer state (see [Section 4.31.4.4, "State Sequence Control"](#)). The comparator control register also allows the type of access to be included in the comparison through the use of the RWE, RW, SZE, and SZ bits. The RWE bit controls whether read or write comparison is enabled for the associated comparator and the RW bit selects either a read or write access for a valid match. Similarly the SZE and SZ bits allows the size of access (word or byte) to be considered in the compare. Only comparator B features SZE and SZ.

The TAG bit in each comparator control register is used to determine the match condition. By setting TAG, the comparator qualifies a match with the output of opcode tracking logic and a state sequencer transition occurs when the tagged instruction reaches the CPU execution stage. Whilst tagging the RW, RWE, SZE, and SZ bits and the comparator data registers are ignored; the comparator address register must be loaded with the exact opcode address.

If the TAG bit is clear (forced type match), a comparator match is generated when the selected address appears on the system address bus. If the selected address is an opcode address, the match is generated when the opcode is fetched from the memory, which precedes the instruction execution by an indefinite number of cycles due to instruction pipelining. For a comparator match of an opcode at an odd address when TAG = 0, the corresponding even address must be contained in the comparator register. Thus for an opcode at odd address (n), the comparator register must contain address (n-1).

Once a successful comparator match has occurred, the condition causing the original match is not verified again on subsequent matches. Thus if a particular data value is verified at a given address, this address may not still contain the data value when a subsequent match occurs.

Match[0, 1, 2] map directly to Comparators [A, B, C] respectively, except in range modes (see [Section 4.31.3.2.4, "Debug Control Register2 \(DBGC2\)"](#)). Comparator channel priority rules are described in the priority section ([Section 4.31.4.3.4, "Channel Priorities"](#)).

#### 4.31.4.2.1 Exact Address Comparator Match (Comparators A and C)

With range comparisons disabled, the match condition is an exact equivalence of address/data bus with the value stored in the comparator address/data registers. Further qualification of the type of access (R/W, word/byte) is possible.

Comparators A and C do not feature SZE or SZ control bits, thus the access size is not compared. The exact address is compared, thus with the comparator address register loaded with address (n) a word access of address (n-1) also accesses (n) but does not cause a match. Table 313 lists access considerations without data bus compare. Table 312 lists access considerations with data bus comparison. To compare byte accesses DBGADH must be loaded with the data byte and the low byte must be masked out using the DBGADLM mask register. On word accesses the data byte of the lower address is mapped to DBGADH.

**Table 312. Comparator A Data Bus Considerations**

Access	Address	DBGADH	DBGADL	DBGADHM	DBGADLM	Example Valid Match
Word	ADDR[n]	Data[n]	Data[n+1]	\$FF	\$FF	MOVW # \$WORD ADDR[n]
Byte	ADDR[n]	Data[n]	x	\$FF	\$00	MOVB # \$BYTE ADDR[n]
Word	ADDR[n]	Data[n]	x	\$FF	\$00	MOVW # \$WORD ADDR[n]
Word	ADDR[n]	x	Data[n+1]	\$00	\$FF	MOVW # \$WORD ADDR[n]

Comparator A features an NDB control bit to determine if a match occurs when the data bus differs to comparator register contents, or when the data bus is equivalent to the comparator register contents.

#### 4.31.4.2.2 Exact Address Comparator Match (Comparator B)

Comparator B features SZ and SZE control bits. If SZE is clear, then the comparator address match qualification functions the same as for comparators A and C.

If the SZE bit is set the access size (word or byte) is compared with the SZ bit value such that only the specified type of access causes a match. Thus if configured for a byte access of a particular address, a word access covering the same address does not lead to match.

**Table 313. Comparator Access Size Considerations**

Comparator	Address	SZE	SZ8	Condition For Valid Match
Comparators A and C	ADDR[n]	—	—	Word and byte accesses of ADDR[n] <sup>(186)</sup> MOVB # \$BYTE ADDR[n] MOVW # \$WORD ADDR[n]
Comparator B	ADDR[n]	0	X	Word and byte accesses of ADDR[n] <sup>(186)</sup> MOVB # \$BYTE ADDR[n] MOVW # \$WORD ADDR[n]
Comparator B	ADDR[n]	1	0	Word accesses of ADDR[n] <sup>(186)</sup> MOVW # \$WORD ADDR[n]
Comparator B	ADDR[n]	1	1	Byte accesses of ADDR[n] MOVB # \$BYTE ADDR[n]

Note:

186. A word access of ADDR[n-1] also accesses ADDR[n] but does not generate a match. The comparator address register must contain the exact address used in the code.

#### 4.31.4.2.3 Range Comparisons

Using the AB comparator pair for a range comparison, the data bus can also be used for qualification by using the comparator A data registers. Furthermore the DBGACTL RW and RWE bits can be used to qualify the range comparison on either a read or a write access. The corresponding DBGBCTL bits are ignored. The SZE and SZ control bits are ignored in range mode. The comparator A TAG bit is used to tag range comparisons. The comparator B TAG bit is ignored in range modes. In order for a range comparison using comparators A

and B, both COMPEA and COMPEB must be set; to disable range comparisons both must be cleared. The comparator A BRK bit is used to for the AB range, the comparator B BRK bit is ignored in range mode.

When configured for range comparisons and tagging, the ranges are accurate only to word boundaries.

#### 4.31.4.2.3.1 Inside Range ( $\text{CompA\_Addr} \leq \text{address} \leq \text{CompB\_Addr}$ )

In the Inside Range comparator mode, comparator pair A and B can be configured for range comparisons. This configuration depends upon the control register (DBG2). The match condition requires a valid match for both comparators happens on the same bus cycle. A match condition on only one comparator is not valid. An aligned word access which straddles the range boundary is valid only if the aligned address is inside the range.

#### 4.31.4.2.3.2 Outside Range ( $\text{address} < \text{CompA\_Addr}$ or $\text{address} > \text{CompB\_Addr}$ )

In the outside range comparator mode, comparator pair A and B can be configured for range comparisons. A single match condition on either of the comparators is recognized as valid. An aligned word access which straddles the range boundary is valid only if the aligned address is outside the range.

Outside range mode in combination with tagging can be used to detect if the opcode fetches are from an unexpected range. In forced match mode the outside range match would typically be activated at any interrupt vector fetch or register access. This can be avoided by setting the upper range limit to \$3FFFF or lower range limit to \$00000 respectively.

### 4.31.4.3 Match Modes (Forced or Tagged)

Match modes are used as qualifiers for a state sequencer change of state. The Comparator control register TAG bits select the match mode. The modes are described in the following sections.

#### 4.31.4.3.1 Forced Match

When configured for forced matching, a comparator channel match can immediately initiate a transition to the next state sequencer state whereby the corresponding flags in DBGSR are set. The state control register for the current state determines the next state. Forced matches are typically generated 2-3 bus cycles after the final matching address bus cycle, independent of comparator RWE/RW settings. Furthermore since opcode fetches occur several cycles before the opcode execution a forced match of an opcode address typically precedes a tagged match at the same address.

#### 4.31.4.3.2 Tagged Match

If a CPU taghit occurs a transition to another state, sequencer state is initiated, and the corresponding DBGSR flags are set. For a comparator related taghit to occur, the DBG must first attach tags to instructions as they are fetched from memory. When the tagged instruction reaches the execution stage of the instruction queue a taghit is generated by the CPU. This can initiate a state sequencer transition.

#### 4.31.4.3.3 Immediate Trigger

Independent of comparator matches it is possible to initiate a tracing session and/or breakpoint, by writing to the TRIG bit in DBG1. This forces the state sequencer into the Final State and issues a forced breakpoint request to the CPU.

#### 4.31.4.3.4 Channel Priorities

In case of simultaneous matches, the priority is resolved according to [Table 314](#). The lower priority is suppressed. It is thus possible to miss a lower priority match if it occurs simultaneously with a higher priority. The priorities described in [Table 314](#) dictate that in the case of simultaneous matches, the match on the lower channel number (0,1,2) has priority. The SC[2:0] encoding ensures a match leading to final state has priority over all other matches independent of current state sequencer state. When configured for range mode on Comparators A/B, match0 has priority whilst match2 is suppressed if a simultaneous range and Comparator C match occur.

**Table 314. Channel Priorities**

Priority	Source	Action
Highest	TRIG	Enter Final State
	Match0 (force or tag hit)	Transition to next state as defined by state control registers
	Match1 (force or tag hit)	Transition to next state as defined by state control registers
Lowest	Match2 (force or tag hit)	Transition to next state as defined by state control registers

**4.31.4.4 State Sequence Control**

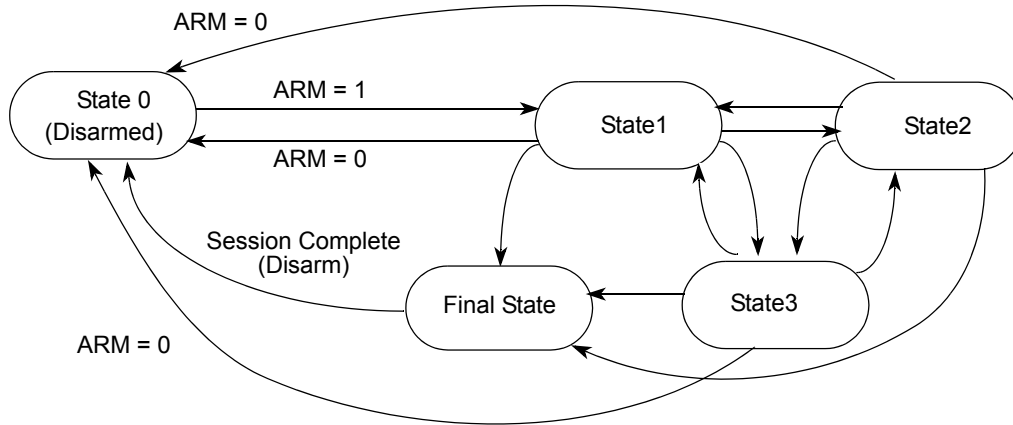

**Figure 69. State Sequencer Diagram**

The state sequencer allows a defined sequence of events to provide a trigger point for tracing of data in the trace buffer. Once the DBG module has been armed by setting the ARM bit in the DBGSC1 register, then state1 of the state sequencer is entered. Further transitions between the states are then controlled by the state control registers and channel matches. The only permitted transition from Final State is back to the disarmed state0. Transition between any of the states 1 to 3 is not restricted. Each transition updates the SSF[2:0] flags in DBGSR accordingly to indicate the current state.

Alternatively writing to the TRIG bit in DBGSC1, the Final State is entered and tracing starts immediately if the TSOURCE bit is configured for tracing.

Independent of the state sequencer, each comparator channel can be individually configured to generate an immediate breakpoint when a match occurs through the use of the BRK bits in the DBGxCTL registers. Thus it is possible to generate an immediate breakpoint on selected channels, whilst a state sequencer transition can be initiated by a match on other channels. If a debug session is ended by a match on a channel with BRK = 1, the state sequencer transitions through Final State for a clock cycle to state0. This is independent of tracing and breakpoint activity, thus with tracing and breakpoints disabled, the state sequencer enters state0 and the debug module is disarmed.

**4.31.4.4.1 Final State**

On entering Final State, a trigger may be issued to the trace buffer according to the trace alignment control, as defined by the TALIGN bit (see Section 4.31.3.2.3, "Debug Trace Control Register (DBGTCR)"). If the TSOURCE bit in DBGTCR is clear then the trace buffer is disabled and the transition to Final State can only generate a breakpoint request. In this case, or upon completion of a tracing session when tracing is enabled, the ARM bit in the DBGSC1 register is cleared, returning the module to the disarmed state0. If tracing is enabled a breakpoint request can occur at the end of the tracing session. If neither tracing nor breakpoints are enabled then when the final state is reached it returns automatically to state0 and the debug module is disarmed.

#### 4.31.4.5 Trace Buffer Operation

The trace buffer is a 64 lines deep by 20-bits wide RAM array. The DBG module stores trace information in the RAM array in a circular buffer format. The system accesses the RAM array through a register window (DBGTBH:DBGTBL) using 16-bit wide word accesses. After each complete 20-bit trace buffer line is read, an internal pointer into the RAM increments so the next read receives fresh information. Data is stored in the format shown in [Table 315](#). After each store, the counter register DBGCNT is incremented. Tracing of CPU activity is disabled when the BDM is active. Reading the trace buffer, whilst the DBG is armed, returns invalid data and the trace buffer pointer is not incremented.

##### 4.31.4.5.1 Trace Trigger Alignment

Using the TALIGN bit (see [Section 4.31.3.2.3, "Debug Trace Control Register \(DBGTCR\)"](#)) it is possible to align the trigger with the end or the beginning of a tracing session.

If End tracing is selected, tracing begins when the ARM bit in DBGC1 is set and State1 is entered; the transition to Final State signals the end of the tracing session. Tracing with Begin Trigger starts at the opcode of the trigger. Using End Trigger, or when the tracing is initiated by writing to the TRIG bit whilst configured for Begin-Trigger, tracing starts at the second opcode after writing to DBGC1

##### 4.31.4.5.1.1 Storing with Begin Trigger

Storing with Begin Trigger, data is not stored in the Trace Buffer until the Final State is entered. Once the trigger condition is met the DBG module remains armed until 64 lines are stored in the Trace Buffer. If the trigger is at the address of the change-of-flow instruction, the change of flow associated with the trigger is stored in the Trace Buffer. Using Begin Trigger together with tagging, if the tagged instruction is about to be executed, then the trace is started. Upon completion of the tracing session, the breakpoint is generated, thus the breakpoint does not occur at the tagged instruction boundary.

##### 4.31.4.5.1.2 Storing with End Trigger

Storing with End Trigger, data is stored in the Trace Buffer until the Final State is entered, at which point the DBG module becomes disarmed and no more data is stored. If the trigger is at the address of a change of flow instruction the trigger event is not stored in the Trace Buffer.

##### 4.31.4.5.2 Trace Modes

Four trace modes are available. The mode is selected using the TRCMOD bits in the DBGTCR register. Tracing is enabled using the TSOURCE bit in the DBGTCR register. The modes are described in the following subsections. The trace buffer organization is shown in [Table 315](#).

##### 4.31.4.5.3 Normal Mode

In Normal mode, change of flow (COF) program counter (PC) addresses is stored.

COF addresses are defined as follows:

- Source address of taken conditional branches (long, short, bit-conditional, and loop primitives)
- Destination address of indexed JMP, JSR, and CALL instruction
- Destination address of RTI, RTS, and RTC instructions
- Vector address of interrupts, except for BDM vectors

LBRA, BRA, BSR, BGND, as well as non-indexed JMP, JSR, and CALL instructions, are not classified as change of flow and are not stored in the trace buffer.

Stored information includes the full 18-bit address bus and information bits, which contains a source/destination bit to indicate whether the stored address was a source address or destination address.

**NOTE**

When a COF instruction with destination address is executed, the destination address is stored to the trace buffer on instruction completion, indicating the COF has taken place. If an interrupt occurs simultaneously, then the next instruction carried out is actually from the interrupt service routine. The instruction at the destination address of the original program flow gets executed after the interrupt service routine.

In the following example, an IRQ interrupt occurs during execution of the indexed JMP at address MARK1. The BRN at the destination (SUB\_1) is not executed until after the IRQ service routine, but the destination address is entered into the trace buffer to indicate the indexed JMP COF has taken place.

```

MARK1  LDX      #SUB_1
MARK1  JMP      0,X          ; IRQ interrupt occurs during execution of this
MARK2  NOP
MARK2  ;

SUB_1   BRN      *          ; JMP Destination address TRACE BUFFER ENTRY 1
SUB_1   ;                ; RTI Destination address TRACE BUFFER ENTRY 3
SUB_1   NOP
ADDR1  DBNE     A,PART5    ; Source address TRACE BUFFER ENTRY 4

IRQ_ISR LDAB     #$F0       ; IRQ Vector $FFF2 = TRACE BUFFER ENTRY 2
IRQ_ISR STAB     VAR_C1
IRQ_ISR RTI

```

The execution flow taking into account the IRQ is as follows

```

MARK1  LDX      #SUB_1
MARK1  JMP      0,X          ;
IRQ_ISR LDAB     #$F0       ;
IRQ_ISR STAB     VAR_C1    ;
IRQ_ISR RTI              ;
SUB_1   BRN      *          ;
SUB_1   NOP              ;
ADDR1  DBNE     A,PART5    ;

```

**4.31.4.5.3.1 Loop1 Mode**

**NOTE**

In certain very tight loops, the source address has already been fetched again before the background comparator is updated. This results in the source address being stored twice before further duplicate entries are suppressed. This condition occurs with branch-on-bit instructions when the branch is fetched by the first P-cycle of the branch or with loop-construct instructions in which the branch is fetched with the first or second P cycle. See examples below:

Loop1 mode, similarly to Normal mode also stores only COF address information to the trace buffer, it however allows the filtering out of redundant information.

The intent of Loop1 mode is to prevent the Trace Buffer from being filled entirely with duplicate information from a looping construct such as delays using the DBNE instruction or polling loops using BRSET/BRCLR instructions. Immediately after address information is placed in the Trace Buffer, the DBG module writes this value into a background register. This prevents consecutive duplicate address entries in the Trace Buffer resulting from repeated branches.

Loop1 mode only inhibits consecutive duplicate source address entries which would typically be stored in most tight looping constructs. It does not inhibit repeated entries of destination addresses or vector addresses, since repeated entries of these would most likely indicate a bug in the user's code which the DBG module is designed to help find.

```

LOOP   INX
LOOP   BRCLR          CMPTMP,#$0c,LOOP ; 1-byte instruction fetched by 1st P-cycle of BRCLR
LOOP   ;                ; the BRCLR instruction also is fetched by 1st
LOOP   ;                ; P-cycle of BRCLR

LOOP2  BRN      *          ; 2-byte instruction fetched by 1st P-cycle of DBNE
LOOP2  NOP
LOOP2  DBNE     A,LOOP2    ; 1-byte instruction fetched by 2nd P-cycle of DBNE
LOOP2  ;                ; this instruction also fetched by 2nd P-cycle of DBNE

```

#### 4.31.4.5.3.2 Detail Mode

In Detail Mode, address and data for all memory and register accesses is stored in the trace buffer. This mode is intended to supply additional information on indexed, indirect addressing modes, where storing only the destination address would not provide all information required for a user to determine where the code is in error. This mode also features information bit storage to the trace buffer, for each address byte storage. The information bits indicates the size of access (word or byte) and the type of access (read or write).

When tracing in Detail mode, all cycles are traced except those when the CPU is either in a free or opcode fetch cycle.

#### 4.31.4.5.3.3 Pure PC Mode

**NOTE:**

When tracing is terminated using forced breakpoints, latency in breakpoint generation means opcodes following the opcode causing the breakpoint can be stored to the trace buffer. The number of opcodes is dependent on program flow. This should be avoided by using tagged breakpoints.

In Pure PC mode, tracing from the CPU the PC addresses of all executed opcodes, including illegal opcodes are stored.

#### 4.31.4.5.4 Trace Buffer Organization

ADRH, ADRM, and ADRL denote address high, middle, and low byte respectively. CRW and CSZ indicate R/W and size access information. The numerical suffix refers to the tracing count. The information format for Loop1, Pure PC and Normal modes is identical. In Detail mode, the address and data for each entry are stored on consecutive lines. Thus, the maximum number of entries is 32. In this case, DBGCNT bits are incremented twice, once for the address line and once for the data line, on each trace buffer entry.

Single byte data accesses in Detail mode is always stored to the low byte of the trace buffer (DATAL) and the high byte is cleared. When tracing word accesses, the byte at the lower address is always stored to trace buffer byte1, and the byte at the higher address is stored to byte0.

**Table 315. Trace Buffer Organization (20-bit wide buffer)**

Mode	Entry Number	4-bits	8-bits	8-bits
		Field 2	Field 1	Field 0
Detail Mode	Entry 1	CSZ1,CRW1,ADRH1	ADRM1	ADRL1
		0	DATAH1	DATAL1
	Entry 2	CSZ2,CRW2,ADRH2	ADRM2	ADRL2
		0	DATAH2	DATAL2
Other Modes	Entry 1	PCH1	PCM1	PCL1
	Entry 2	PCH2	PCM2	PCL2

#### 4.31.4.5.4.1 Information Bit Organization

The format of the bits is dependent upon the active trace mode, as described by the following.

#### 4.31.4.5.4.2 Field2 Bits in Detail Mode

**Table 316. Field2 Information Bits in Detail Mode**

Bit 3	Bit 2	Bit 1	Bit 0
CSZ	CRW	ADRH17	ADRH16

In Detail mode, the CSZ and CRW bits indicate the type of access being made by the CPU.

**Table 317. Field Descriptions**

Field	Description
3 CSZ	<b>Access Type Indicator</b> — This bit indicates if the access was a byte or word size when tracing in Detail mode 0 Word Access 1 Byte Access
2 CRW	<b>Read Write Indicator</b> — This bit indicates if the corresponding stored address corresponds to a read or write access when tracing in Detail Mode. 0 Write Access 1 Read Access
1 ADRH17	<b>Address Bus bit 17</b> — Corresponds to system address bus bit 17.
0 ADRH16	<b>Address Bus bit 16</b> — Corresponds to system address bus bit 16.

#### 4.31.4.5.4.3 Field2 Bits in Normal, Pure PC and Loop1 Modes

**Table 318. Information Bits PCH**

Bit 3	Bit 2	Bit 1	Bit 0
CSD	CVA	PC17	PC16

**Table 319. PCH Field Descriptions**

Field	Description
3 CSD	<b>Source Destination Indicator</b> — In Normal and Loop1 mode this bit indicates if the corresponding stored address is a source or destination address. This bit has no meaning in Pure PC mode. 0 Source Address 1 Destination Address
2 CVA	<b>Vector Indicator</b> — In Normal and Loop1 mode this bit indicates if the corresponding stored address is a vector address. Vector addresses are destination addresses, thus if CVA is set, then the corresponding CSD is also set. This bit has no meaning in Pure PC mode. 0 Non-Vector Destination Address 1 Vector Destination Address
1 PC17	<b>Program Counter bit 17</b> — In Normal, Pure PC, and Loop1 mode this bit corresponds to program counter bit 17.
0 PC16	<b>Program Counter bit 16</b> — In Normal, Pure PC, and Loop1 mode this bit corresponds to program counter bit 16.

#### 4.31.4.5.5 Reading Data from Trace Buffer

The data stored in the Trace Buffer can be read, provided the DBG module is not armed, is configured for tracing (TSOURCE bit is set) and the system not secured. When the ARM bit is written to 1 the trace buffer is locked to prevent reading. The trace buffer can only be unlocked for reading by a single aligned word write to DBGTB when the module is disarmed.

The Trace Buffer can only be read through the DBGTB register using aligned word reads, any byte or misaligned reads return 0 and do not cause the trace buffer pointer to increment to the next trace buffer address. The Trace Buffer data is read out first-in first-out. By reading CNT in DBGCNT, the number of valid lines can be determined. DBGCNT does not decrement as data is read.

Whilst reading, an internal pointer is used to determine the next line to be read. After a tracing session, the pointer points to the oldest data entry, thus if no overflow has occurred, the pointer points to line0, otherwise it points to the line with the oldest entry. The pointer is initialized by each aligned write to DBGTBH to point to the oldest data again. This enables an interrupted trace buffer read sequence to be easily restarted from the oldest data entry.

The least significant word of line is read out first. This corresponds to the fields 1 and 0 of [Table 315](#). The next word read returns field 2 in the least significant bits [3:0] and “0” for bits [15:4]. Reading the Trace Buffer while the DBG module is armed, returns invalid data, and no shifting of the RAM pointer occurs.

#### 4.31.4.5.6 Trace Buffer Reset State

The Trace Buffer contents and DBGCNT bits are not initialized by a system reset. Thus should a system reset occur, the trace session information from immediately before the reset occurred, can be read out and the number of valid lines in the trace buffer is indicated by DBGCNT. The internal pointer to the current trace buffer address is initialized by unlocking the trace buffer and points to the oldest valid data, even if a reset occurred during the tracing session. To read the trace buffer after a reset, TSOURCE must be set, otherwise the trace buffer reads as all zeroes. Generally debugging occurrences of system resets is best handled using end trigger alignment, since the reset may occur before the trace trigger, which in the begin trigger alignment case means no information would be stored in the trace buffer. The Trace Buffer contents and DBGCNT bits are undefined following a POR

#### 4.31.4.6 Tagging

A tag follows program information as it advances through the instruction queue. When a tagged instruction reaches the head of the queue, a tag hit occurs and can initiate a state sequencer transition.

Each comparator control register features a TAG bit, which controls whether the comparator match causes a state sequencer transition immediately or tags the opcode at the matched address. If a comparator is enabled for tagged comparisons, the address stored in the comparator match address registers must be an opcode address.

Using Begin trigger together with tagging, if the tagged instruction is about to be executed, then the transition to the next state sequencer state occurs. If the transition is to the Final State, tracing is started. Only upon completion of the tracing session can a breakpoint be generated. Using End alignment, when the tagged instruction is about to be executed and the next transition is to Final State, then a breakpoint is generated immediately before the tagged instruction is carried out.

R/W monitoring is not useful for tagged operations, since the taghit occurs based on the tagged opcode reaching the execution stage of the instruction queue. Similarly access size (SZ) monitoring and data bus monitoring is not useful if tagging is selected, since the tag is attached to the opcode at the matched address, and is not dependent on the data bus nor on the size of access. Thus these bits are ignored if tagging is selected.

When configured for range comparisons and tagging, the ranges are accurate only to word boundaries. Tagging is disabled when the BDM becomes active.

#### 4.31.4.7 Breakpoints

It is possible to generate breakpoints from channel transitions to Final State or using software to write to the TRIG bit in the DBG1 register.

##### 4.31.4.7.1 Breakpoints From Comparator Channels

Breakpoints can be generated when the state sequencer transitions to the Final State. If configured for tagging, then the breakpoint is generated when the tagged opcode reaches the execution stage of the instruction queue.

If a tracing session is selected by the TSOURCE bit, breakpoints are requested when the tracing session has completed, thus if Begin aligned triggering is selected, the breakpoint is requested only on completion of the subsequent trace (see [Table 320](#)). If no tracing session is selected, breakpoints are requested immediately. If the BRK bit is set, then the associated breakpoint is generated immediately independent of tracing trigger alignment.

**Table 320. Breakpoint Setup For CPU Breakpoints**

BRK	TALIGN	DBGBRK	Breakpoint Alignment
0	0	0	Fill Trace Buffer until trigger, then disarm (no breakpoints)
0	0	1	Fill Trace Buffer until trigger, then breakpoint request occurs
0	1	0	Start Trace Buffer at trigger (no breakpoints)

**Table 320. Breakpoint Setup For CPU Breakpoints (continued)**

0	1	1	Start Trace Buffer at trigger, A breakpoint request occurs when Trace Buffer is full
1	x	1	Terminate tracing and generate breakpoint immediately on trigger
1	x	0	Terminate tracing immediately on trigger

#### 4.31.4.7.2 Breakpoints Generated Via the TRIG Bit

If a TRIG triggers occur, the Final State is entered whereby tracing trigger alignment is defined by the TALIGN bit. If a tracing session is selected by the TSOURCE bit, breakpoints are requested when the tracing session has completed, thus if Begin aligned triggering is selected, the breakpoint is requested only on completion of the subsequent trace (see [Table 320](#)). If no tracing session is selected, breakpoints are requested immediately. TRIG breakpoints are possible even if the DBG module is disarmed.

#### 4.31.4.7.3 Breakpoint Priorities

If a TRIG trigger occurs after Begin aligned tracing has already started, then the TRIG no longer has an effect. When the associated tracing session is complete, the breakpoint occurs. Similarly if a TRIG is followed by a subsequent comparator channel match, it has no effect, since tracing has already started.

If a forced SWI breakpoint coincides with a BGND in user code with BDM enabled, then the BDM is activated by the BGND and the breakpoint to SWI is suppressed.

##### 4.31.4.7.3.1 DBG Breakpoint Priorities and BDM Interfacing

###### NOTE

When program control returns from a tagged breakpoint using an RTI or BDM GO command without program counter modification, it returns to the instruction whose tag generated the breakpoint. To avoid a repeated breakpoint at the same location, reconfigure the DBG module in the SWI routine, if configured for an SWI breakpoint, or over the BDM interface, by executing a TRACE command before the GO to increment the program flow past the tagged instruction.

Breakpoint operation is dependent on the state of the BDM module. If the BDM module is active, the CPU is executing out of BDM firmware, thus comparator matches and associated breakpoints are disabled. In addition, while executing a BDM TRACE command, tagging into BDM is disabled. If BDM is not active, the breakpoint gives priority to BDM requests over SWI requests, if the breakpoint happens to coincide with a SWI instruction in user code. On returning from BDM, the SWI from user code gets executed.

**Table 321. Breakpoint Mapping Summary**

DBGBRK	BDM Bit (DBGC1[4])	BDM Enabled	BDM Active	Breakpoint Mapping
0	X	X	X	No Breakpoint
1	0	X	0	Breakpoint to SWI
X	X	1	1	No Breakpoint
1	1	0	X	Breakpoint to SWI
1	1	1	0	Breakpoint to BDM

BDM cannot be entered from a breakpoint unless the ENABLE bit is set in the BDM. If entry to BDM via a BGND instruction is attempted and the ENABLE bit in the BDM is cleared, the CPU actually executes the BDM firmware code, checks the ENABLE, and returns if ENABLE is not set. If not serviced by the monitor, then the breakpoint is re-asserted when the BDM returns to normal CPU flow.

If the comparator register contents coincide with the SWI/BDM vector address, then an SWI in user code and DBG breakpoint could occur simultaneously. The CPU ensures BDM requests have a higher priority than SWI requests. Returning from the BDM/SWI service routine, care must be taken to avoid a repeated breakpoint at the same address.

Should a tagged or forced breakpoint coincide with a BGND in user code, then the instruction following the BGND instruction is the first instruction executed when normal program execution resumes.

## 4.32 S12S Clocks and Reset Generator (S12SCRGV1)

### 4.32.1 Introduction

This specification describes the function of the Clocks and Reset Generator (S12SCRGV1).

#### 4.32.1.1 Features

The main features of this block are:

- Internal 32 kHz reference clock generator:
  - Trimmable in frequency
  - $\pm 2\%$  deviation over voltage and temperature for a fixed trim value.
  - Factory trimmed value in Flash Memory
- Optional external crystal or resonator:
  - Full swing Pierce Oscillator for crystals or resonators from 4.0 MHz to 16 MHz
  - Oscillator Monitor to detect loss of clock
- Internal digitally controlled oscillator (DCO):
  - Allows to generate frequencies in the range from 32 MHz to 40 MHz
  - Stable frequency by using a reference clock in a Frequency Locked Loop (FLL).
  - FLL based on either Internal Reference Clock (32 kHz) or optional external crystal/resonator (for higher accuracy).
  - Interrupt request on entry or exit from FLL locked condition
- Bus Clock Generator
  - Clock switch for DCO or optional external crystal/resonator based Bus Clock
  - Bus Clock divider to choose system speed
- System Reset generation from the following possible sources:
  - Power-on detect
  - Illegal address access
  - COP timeout
  - Loss of external Oscillator Clock (Oscillator monitor fail)
  - External pin  $\overline{\text{RESET}}$

#### 4.32.1.2 Modes of Operation

This subsection lists and briefly describes all operating modes supported by the 9S12I32PIMV1.

##### 4.32.1.2.1 Run Mode

- FLL Engaged Internal (FEI)
  - This is the default mode after System Reset and Power-on Reset.
  - The FLL reference is the Internal Reference Clock.
  - The Bus Clock is based on the DCO Clock.
- FLL Engaged External (FEE)
  - This mode is entered by:
    - enabling the external Oscillator (OSCEN bit)
    - programming the reference divider (RDIV[2:0] bits)
    - selecting the divided down Oscillator Clock as FLL reference clock (REFS bit)
  - The FLL reference is the Oscillator Clock.
  - The Bus Clock is based on the DCO Clock.
- FLL Bypassed External (FBE)
  - This mode is entered by:
    - enabling the external Oscillator (OSCEN bit)
    - selecting the Oscillator Clock as basis for Bus Clock (BCLKS bit)
  - The DCO Clock is turned off.
  - The Bus Clock is based on the Oscillator Clock.

**4.32.1.2.2 Wait Mode**

For 9S12I32PIMV1 Wait mode is same as Run mode.

**4.32.1.2.3 Stop Mode**

- This mode is entered by executing the CPU STOP instruction.
- The Bus Clock is turned off.
- The Oscillator Clock and the Oscillator Monitor is turned off.
- The DCO Clock is turned off.
- The Internal Reference Clock can be kept enabled by peripherals like e.g. the Real Time Interrupt module (RTI). See device and other block descriptions for details.

**4.32.1.3 Block Diagram**

Figure 70 shows a block diagram of the 9S12I32PIMV1.

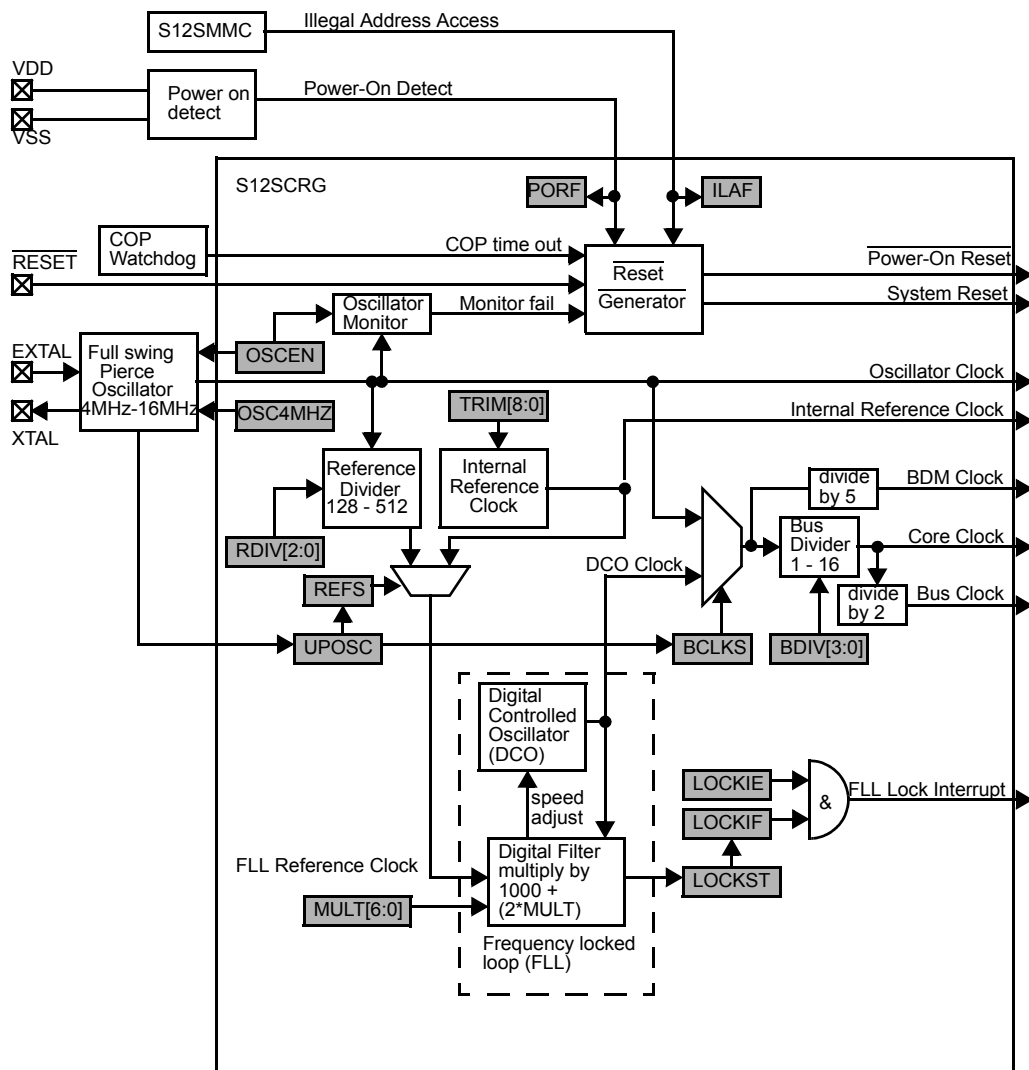

**Figure 70. Block diagram of 9S12I32PIMV1**

## 4.32.2 Signal Description

This section lists and describes the signals connecting off chip.

### 4.32.2.1 RESET

$\overline{\text{RESET}}$  is an active low bidirectional reset pin. As an input it initializes the MCU asynchronously to a known start-up state. As an open-drain output it indicates a System Reset or Power-on Reset (internal to MCU) has been triggered.

## 4.32.3 Memory Map and Registers

This section provides a detailed description of all registers accessible in the 9S12I32PIMV1.

### 4.32.3.1 Module Memory Map

Table 322 gives an overview on all 9S12I32PIMV1 registers.

**Table 322. 9S12I32PIMV1 Register Summary**

Address	Name		Bit 7	6	5	4	3	2	1	Bit 0
0x0034	CRGCTL0	R	OSCEN	RDIV[2:0]			BCLKS	REFS	OSC4MHZ	0
		W								
0x0035	CRGCTL1	R	BDIV[3:0]				0	0	LOCKIE	0
		W								
0x0036	CRGMULT	R	0	MULT[6:0]						
		W								
0x0037	CRGFLG	R	0	PORF	0	LOCKIF	LOCKST	ILAF	UPOSC	0
		W								
0x0038	CRGTRIMH	R	0	0	0	0	0	0	0	TRIM[8]
		W								
0x0039	CRGTRIML	R	TRIM[7:0]							
		W								
0x003A	CRGTEST0 (Reserved)	R	0	0	0	0	0	0	0	0
		W								
0x003B	CRGTEST1 (Reserved)	R	U	U	U	U	U	U	U	U
		W								

### 4.32.3.2 Register Descriptions

This section describes in address order all the 9S12I32PIMV1 registers and their individual bits.

### 4.32.3.2.1 9S12I32PIMV1 Control Register 0 (CRGCTL0)

**Table 323. 9S12I32PIMV1 Control Register 0 (CRGCTL0)**

0x0034

	7	6	5	4	3	2	1	0
R	OSCEN	RDIV[2:0]			BCLKS	REFS	OSC4MHZ	0
W								0
Reset	0	0	0	0	0	0	0	0

Read: Anytime

Write: See individual bit descriptions.

Writing the CRGCTL0 register clears the LOCKST bit, but does not set the LOCKIF bit in the CRGFLG register.

**Table 324. CRGCTL0 Field Descriptions**

Field	Description
7 OSCEN	Oscillator Enable Bit 0 Oscillator Clock and Oscillator Monitor are disabled. 1 Oscillator Clock and Oscillator Monitor are enabled.
6, 5, 4 RDIV[2:0]	Reference Divider Bits These bits divide the Oscillator Clock down in frequency. Divided down frequency must be in the allowed range for $f_{FLLREF}$ . See device electrical characteristics for details. 000 divide by 128 001 divide by 160 010 divide by 192 011 divide by 256 100 divide by 320 101 divide by 384 110 divide by 512 111 Reserved
3 BCLKS	Bus Clock Source Select Bit Writing BCLKS = 1 is only possible if oscillator startup flag is set (UPOSC = 1). BCLKS is cleared with disabling the Oscillator, which is either OSCEN = 0 or entering Stop Mode. 0 DCO Clock is selected as basis for the Bus Clock. 1 Oscillator Clock is selected as basis for the Bus Clock. DCO is disabled.
2 REFS	Reference Select Bit Writing REFS = 1 is only possible if oscillator startup flag is set (UPOSC = 1). REFS is cleared with disabling the Oscillator, which is either OSCEN = 0 or entering Stop Mode. 0 Internal Reference Clock is selected as FLL Reference Clock. 1 Divided down Oscillator Clock is selected as FLL Reference Clock.
1 OSC4MHZ	4.0 MHz Oscillator low pass filter select Bit The Oscillator contains a noise filter in its signal path from EXTAL/XTAL to chip internal Oscillator Clock. This is to improve high frequency noise immunity. Writing OSC4MHZ is only possible if OSCEN was zero before. 0 Oscillator uses noise filter with high bandwidth. To be used with crystals/resonators > 4.0 Mhz. 1 Oscillator uses noise filter with low bandwidth. To be used with crystals/resonators = 4.0 Mhz. Choosing a low bandwidth in case of a 4.0 MHz crystal/resonator further improves noise immunity at lower frequencies.

### 4.32.3.2.2 9S12I32PIMV1 Control Register 1 (CRGCTL1)

**Table 325. 9S12I32PIMV1 Control Register (CRGCTL1)**

0x0035

	7	6	5	4	3	2	1	0
R	BDIV[3:0]				0	0	LOCKIE	0
W								
Reset	0	0	0	0	0	0	0	0

Read: Anytime

Write: Anytime

**Table 326. CRGCTL1 Field Descriptions**

Field	Description
7, 6, 5, 4 BDIV[3:0]	Bus Divider Bits Depending on the setting of the BCLKS bit, either the DCO Clock or the Oscillator Clock is divided down in frequency to create the Core Clock. Bus frequency is Core frequency divided by 2. 0000 divide by 1 0001 divide by 2 0010 divide by 3 0011 divide by 4 0100 divide by 5 0101 divide by 6 0110 divide by 7 0111 divide by 8 1000 divide by 9 1001 divide by 10 1010 divide by 11 1011 divide by 12 1100 divide by 13 1101 divide by 14 1110 divide by 15 1111 divide by 16
1 LOCKIE	FLL Lock Interrupt Enable Bit 0 FLL Lock Interrupt requests are disabled. 1 FLL Lock Interrupt is requested whenever LOCKIF is set.

### 4.32.3.2.3 9S12I32PIMV1 FLL Multiply Register (CRGMULT)

This register determines the multiplication factor to generate the DCO Clock.

**Table 327. 9S12I32PIMV1 FLL Multiply Register (CRGMULT)**

0x0036

	7	6	5	4	3	2	1	0
R	0	MULT[6:0]						
W								
Reset	0	0	0	0	0	0	0	0

Read: Anytime

Write: Anytime

Writing the CRGMULT register clears the LOCKST bit, but does not set the LOCKIF bit in the CRGFLG register.

**Table 328. CRGMULT Field Descriptions**

Field	Description
6, 5, 4, 3, 2, 1, 0 MULT[6:0]	FLL Multiplier Bits DCO Clock locks to RDIV Clock multiplied by (1000 + 2*MULT[6:0]. Depending on the REFS bit, RDIV Clock is either the Internal Reference Clock or the divided down Oscillator Clock. So multiplication factors can be from 1000 to 1254. MULT[6:0] bits must be chosen so the minimum and maximum DCO Clock frequency $f_{DCO}$ is not violated. See <a href="#">Electrical Characteristics</a> for frequency range of $f_{DCO}$ .

**4.32.3.2.4 9S12I32PIMV1 Flags Register (CRGFLG)**

This register provides 9S12I32PIMV1 status bits and flags.

**Table 329. 9S12I32PIMV1 Flags Register (CRGFLG)**

0x0037

	7	6	5	4	3	2	1	0
R	0	PORF	0	LOCKIF	LOCKST	ILAF	UPOSC	0
W								
Reset	0	(187)	0	0	0	(188)	0	0

Note:

- 187. PORF is set to 1 when a Power-On Reset occurs. Unaffected by System Reset.
- 188. ILAF is set to 1 when an illegal address access occurs. Unaffected by System Reset. Cleared by Power-On Reset.

Read: Anytime

Write: Refer to each bit for individual write conditions

**Table 330. CRGFLG Field Descriptions**

Field	Description
6 PORF	<b>Power-on Reset Flag</b> — PORF is set to 1 when a power on reset occurs. This flag can only be cleared by writing a 1. Writing a 0 has no effect. 0 Power-on Reset has not occurred. 1 Power-on Reset has occurred.
4 LOCKIF	<b>FLL Lock Interrupt Flag</b> — LOCKIF is set to 1 when LOCKST status bit changes. This flag can only be cleared by writing a 1. Writing a 0 has no effect. If enabled (LOCKIE = 1), LOCKIF causes an interrupt request. Entering Stop mode or writing registers CRGCTL0, CRGMULT, CRGTRIMH, or CRGTRIML while LOCKST = 1, clears the LOCKST bit, but does not set the LOCKIF bit. 0 No change in LOCKST bit. 1 LOCKST bit has changed.
3 LOCKST	<b>Lock Status Bit</b> — LOCKST reflects the current state of FLL lock condition. Writes have no effect. Entering stop mode or writing registers CRGCTL0, CRGMULT, CRGTRIMH, or CRGTRIML clears the LOCKST bit. 0 DCO Clock is not within the desired tolerance of the target frequency. 1 DCO Clock is within the desired tolerance of the target frequency.

**Table 330. CRGFLG Field Descriptions (continued)**

Field	Description
2 ILAF	<b>Illegal Address Reset Flag</b> — ILAF is set to 1 when an illegal address access occurs. Refer to MMC Block Guide for details. This flag can only be cleared by writing a 1. Writing a 0 has no effect. 0 Illegal address access has not occurred. 1 Illegal address access has occurred.
1 UPOSC	<b>Oscillator Startup Status Bit</b> — UPOSC is set when startup of the oscillator has finished successfully. The oscillator requires a startup time $t_{UPOSC}$ . See <a href="#">Electrical Characteristics</a> for a value. Note that the Oscillator Clock can only be selected as Bus Clock source (BCLKS bit) or FLL Reference Clock (REFS bit) if UPOSC = 1. If despite enabling the Oscillator (OSCEN = 1), the UPOSC flag is not set within $t_{UPOSC}$ , this indicates e.g. a crystal failure. Note that the Oscillator Monitor becomes active <b>after</b> initial oscillator startup, is only for UPOSC=1. UPOSC is cleared with disabling the Oscillator, which is either OSCEN = 0 or entering Stop mode. Writes have no effect. 0 Oscillator has not started up. Oscillator Monitor is inactive. 1 Oscillator has started up. Oscillator Monitor is active.

#### 4.32.3.2.5 9S12I32PIMV1TRIM register (CRGTRIMH, CRGTRIML)

This registers contains the trimmed value for the Internal Reference Clock

**Table 331. 9S12I32PIMV1 TRIM Register High Byte (CRGTRIMH)**

0x0038

	15	14	13	12	11	10	9	8
R	0	0	0	0	0	0	0	TRIM[8]
W								
Reset	0	0	0	0	0	0	0	F

After de-assert of System Reset a factory programmed trim value is automatically loaded from the Flash memory to provide trimmed Internal Reference Frequency  $f_{IREF\_TRIM}$ .

**Table 332. 9S12I32PIMV1 Trim Register Low Byte (CRGTRIML)**

0x0039

	7	6	5	4	3	2	1	0
R	TRIM[7:0]							
W	TRIM[7:0]							
Reset	F	F	F	F	F	F	F	F

After de-assert of System Reset a factory programmed trim value is automatically loaded from the Flash memory to provide trimmed Internal Reference frequency  $f_{IREF\_TRIM}$ .

Read: Anytime

Write: Anytime

Writing the CRGTRIMH or CRGTRIML register clears the LOCKST bit, but does not set the LOCKIF bit in the CRGFLG register.

**Table 333. CRGTRIMH and CRGTRIML Field Descriptions**

Field	Description
8, 7, 6, 5, 4, 3, 2, 1, 0 TRIM[8:0]	Trim Bits for Internal Reference Clock After System Reset, the factory programmed trim value is automatically loaded into this register, resulting in a Internal Reference Frequency $f_{IREF\_TRIM}$ . See <a href="#">Electrical Characteristics</a> for value of $f_{IREF\_TRIM}$ . The TRIM[8:0] bits are binary weighted (i.e., bit 1 adjusts twice as much as bit 0). Decreasing the binary value in TRIM[8:0] increases the frequency, increasing the value decreases the frequency. Trimmed frequency must be in the allowed range for $f_{FLLREF}$ . See device electrical characteristics for details.

**4.32.3.2.6 9S12I32PIMV1 Test Register 0 (CRGTEST0)**

**Table 334. 9S12I32PIMV1 Test Register 0 (CRGTEST0)**

0x003A

	7	6	5	4	3	2	1	0
R	0	0	0	0	0	0	0	0
W								
Reset	0	0	0	0	0	0	0	0

This register is reserved for factory test. This register is not writable.

Read: Anytime  
Write: Not possible

**4.32.3.2.7 9S12I32PIMV1 Test Register 1 (CRGTEST1)**

**Table 335. 9S12I32PIMV1 Test Register 1(CRGTEST1)**

0x003B

	7	6	5	4	3	2	1	0
R	U	U	U	U	U	U	U	U
W								
Reset	U	U	U	U	U	U	U	U

This register is reserved for factory test. This register is not writable.

Read: Anytime

**4.32.4 Write: Not Possible Functional Description**

**4.32.4.1 Startup from Reset**

An example of startup of clock system from Reset is given in [Figure 71](#).

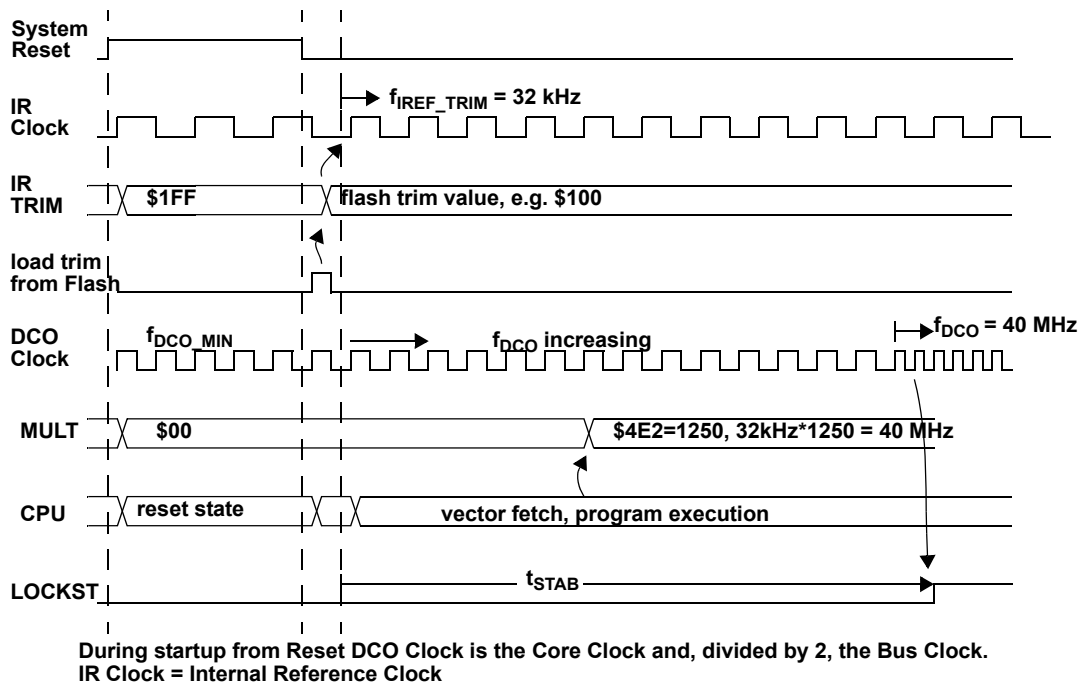

Figure 71. Example for Startup of Clock System After Reset

#### 4.32.4.2 Stop Mode Using DCO Clock as a Bus Clock

An example of what happens going into stop mode and exiting stop mode after an interrupt is shown in [Figure 72](#).

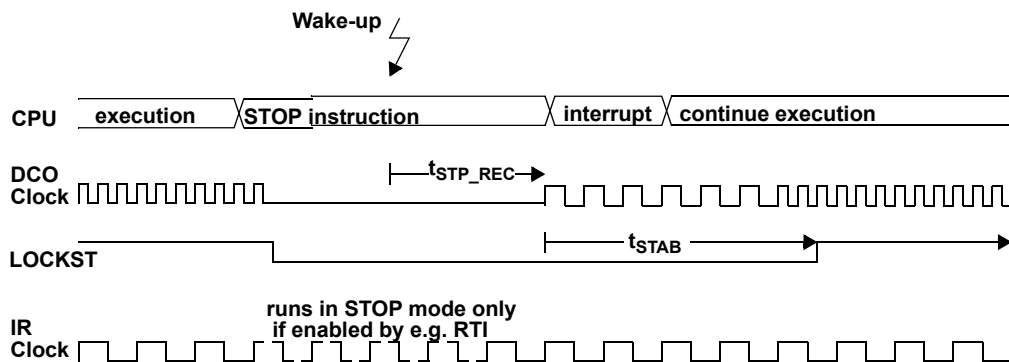

Figure 72. Example of STOP Mode Using DCO Clock as Bus Clock

#### 4.32.4.3 Stop Mode Using Oscillator Clock as Bus Clock

An example of what happens going into stop mode and exiting stop mode after an interrupt is shown in [Figure 73](#).

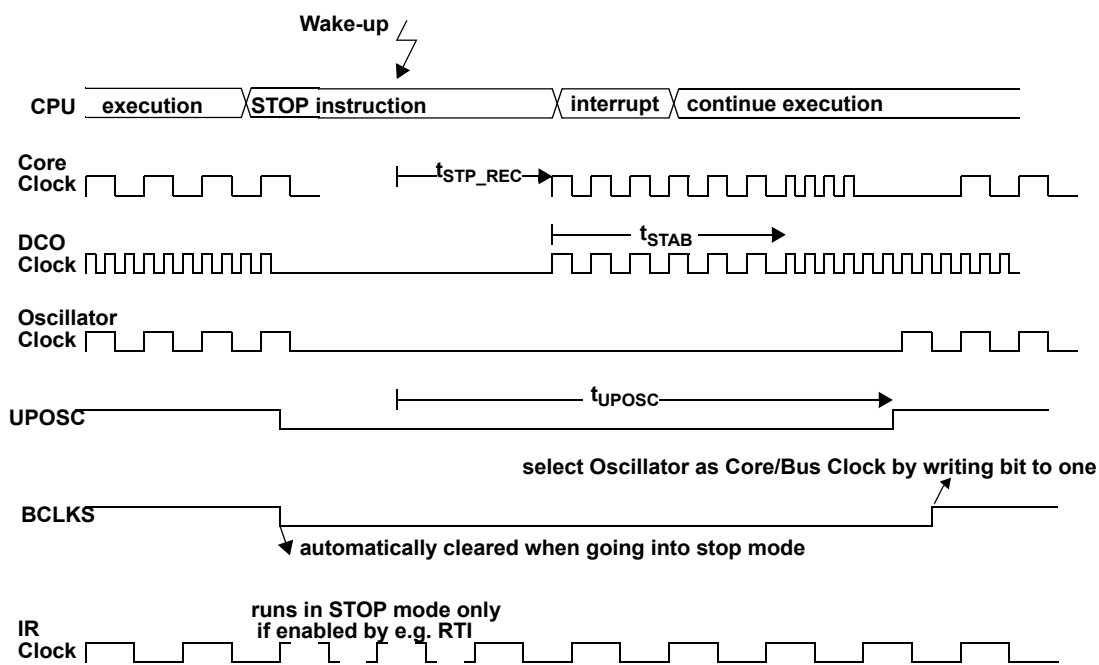

Figure 73. Example of STOP Mode Using Oscillator Clock as a Bus Clock

#### 4.32.4.4 Enabling the External Oscillator

An example of how to use the Oscillator as Bus Clock is shown in Figure 74.

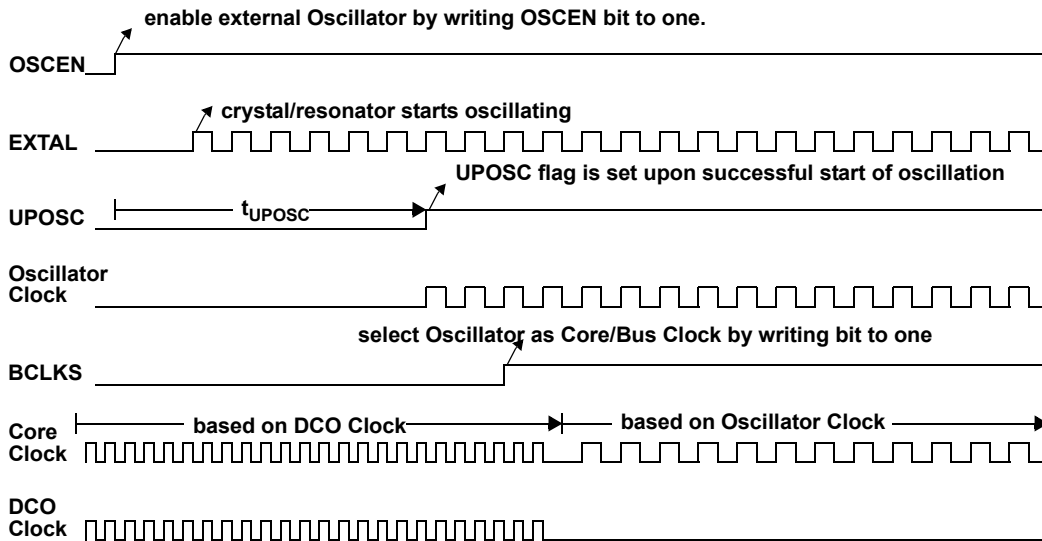

Figure 74. Example for Enabling the External Oscillator

## 4.32.5 Resets

### 4.32.5.1 General

All reset sources are listed in [Table 336](#). Refer to MCU specification for related vector addresses and priorities.

**Table 336. Reset Summary**

Reset Source	Local Enable
Power-On Detect	None
External pin $\overline{\text{RESET}}$	None
Illegal Address Access	None
Oscillator Monitor Fail	CRGCTL0 (OSCN = 1)
COP Watchdog time out	see COP Block Guide

### 4.32.5.2 Description of Reset Operation

**NOTE**

External circuitry connected to the  $\overline{\text{RESET}}$  pin should not include a large capacitance which would interfere with the ability of this signal to rise to a valid logic one within 256 DCO Clock cycles after the low drive is released.

The reset sequence is initiated by any of the following events:

- Low level is detected at the  $\overline{\text{RESET}}$  pin (External Reset).
- Power-on is detected.
- Illegal Address Access is detected (see MMC Block Guide for details).
- COP watchdog times out.
- Oscillator monitor failure is detected.

Upon detection of any reset event, an internal circuit drives the  $\overline{\text{RESET}}$  pin low for 516 DCO Clock cycles. Depending on internal synchronization latency, it can also be 517 DCO Clock cycles (see [Figure 75](#)). Since entry into reset is asynchronous, it does not require a running DCO Clock. However, the internal reset circuit of the 9S12I32PIMV1 cannot sequence out of current reset condition without a running DCO Clock. After 516 DCO Clock cycles, the  $\overline{\text{RESET}}$  pin is released. The reset generator of the 9S12I32PIMV1 waits for additional 256 DCO Clock cycles and then samples the  $\overline{\text{RESET}}$  pin to determine the originating source. [Table 337](#) shows which vector is fetched.

**Table 337. Reset Vector Selection**

Sampled $\overline{\text{RESET}}$ Pin (256 cycles after release)	Oscillator monitor fail pending	COP timeout pending	Vector Fetch
1	0	0	POR /Illegal Address Access/External pin $\overline{\text{RESET}}$
1	1	X	Oscillator Monitor Fail
1	0	1	COP time out
0	X	X	POR /Illegal Address Access/ External pin $\overline{\text{RESET}}$

The internal reset of the MCU remains asserted while the reset generator completes the 768 DCO Clock long reset sequence. In case the  $\overline{\text{RESET}}$  pin is externally driven low for more than these 768 DCO Clock cycles (External Reset), the internal reset remains asserted longer.

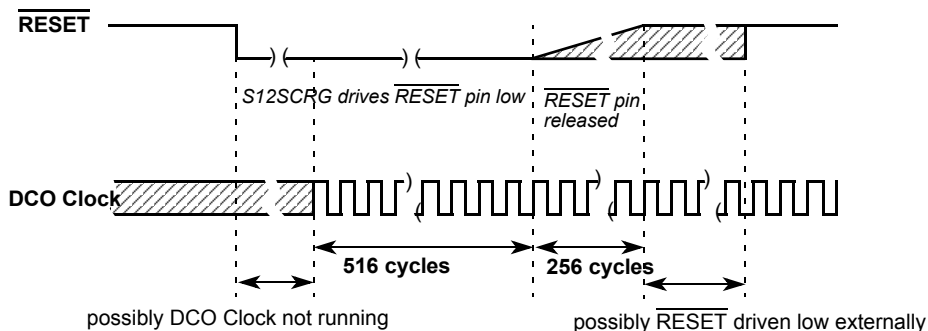

**Figure 75. RESET Timing**

**4.32.5.2.1 Oscillator Monitor Reset**

In case of loss of clock, or the oscillator frequency is below the failure assert frequency  $f_{OMFA}$  (see device electrical characteristics for values), the 9S12I32PIMV1 generates a Oscillator Monitor Reset.

**4.32.5.2.2 Computer Operating Properly Watchdog (COP) Reset**

A COP timeout generates a reset. See COP description for details.

**4.32.5.2.3 Power-On Reset**

The on-chip voltage POR circuitry detects when  $V_{DD}$  to the MCU has reached a certain level and asserts a Power-on reset.

**4.32.6 Interrupts**

The interrupts/reset vectors requested by the 9S12I32PIMV1 are listed in [Table 338](#). Refer to MCU specification for related vector addresses and priorities.

**Table 338. 9S12I32PIMV1 Interrupt Vectors**

Interrupt Source	CCR Mask	Local Enable
FLL LOCK interrupt	1 bit	CRGCTL1 (LOCKIE)

**4.32.6.1 Description of Interrupt Operation**

**4.32.6.1.1 FLL Lock Interrupt**

The 9S12I32PIMV1 generates a FLL Lock interrupt when the lock condition (LOCKST status bit) of the FLL has changed, either from a locked state to an unlocked state or vice versa. Lock interrupts are locally disabled by setting the LOCKIE bit to zero. The FLL Lock interrupt flag (LOCKIF) is set to 1 when the lock condition has changed, and is cleared to 0 by writing a 1 to the LOCKIF bit.

**4.33 External Oscillator (S12SOSCFPV1)**

**4.33.1 Introduction**

The full swing Pierce oscillator (OSCFSP) module provides a robust clock source with an external crystal or ceramic resonator.

**4.33.2 Features**

The S12SCRG module provides the following features:

- Full rail-to-rail (2.5 V nominal) swing oscillation with low EM susceptibility
- High noise immunity due to input hysteresis
- Low power consumption due to operation with 2.5 V (nominal) supply

### 4.33.3 Modes of Operation

The OSCFSP contains the registers and associated bits for controlling and monitoring the oscillator module. Two modes of operation exist:

1. Off (OSCEN=0)
2. Full swing Pierce oscillator (OSCEN=1)

### 4.33.4 Block Diagram

Figure 76 shows a block diagram of the OSCFSP module.

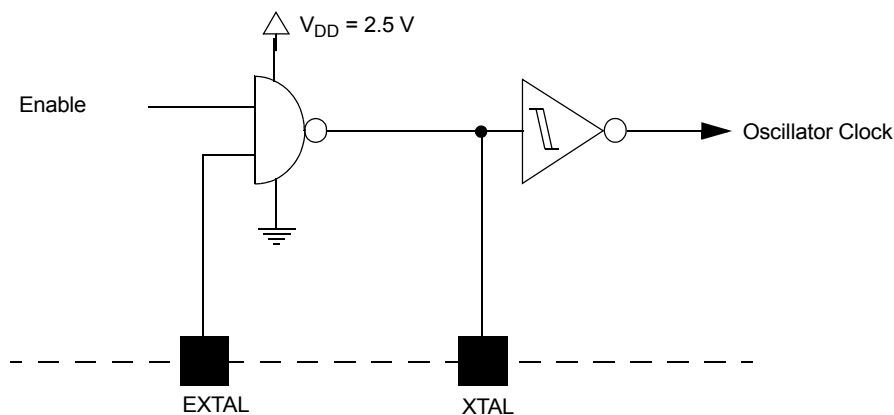

Figure 76. OSCFSP Block Diagram

### 4.33.5 External Signals EXTAL and XTAL — Input and Output Pins

**NOTE**

Freescale recommends an evaluation of the application board, and chosen resonator or crystal, by the resonator or crystal supplier. The oscillator circuit is not suited for overtone resonators and crystals.

EXTAL is the input to the crystal oscillator amplifier. XTAL is the output of the crystal oscillator amplifier.

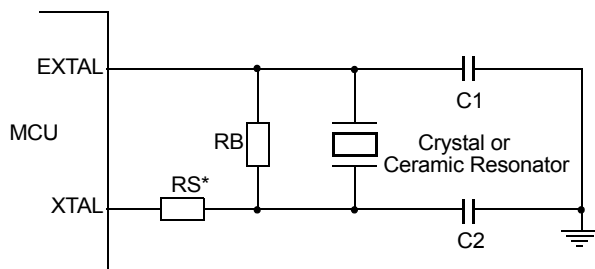

\*  $R_S$  can be zero (shorted) when use with higher frequency crystals. Refer to manufacturer's data.

Figure 77. Full Swing Pierce Oscillator Connections

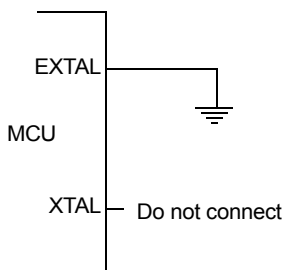

**Figure 78. External Connections, if OSCFSP is Unused**

The circuit shown in Figure 77 is recommended when using either a crystal or a ceramic resonator. If OSCFSP is not used, it is recommended to pull the EXTAL input pin to GND, as shown in Figure 78. In Off mode the XTAL output is forced to  $V_{DD}$  by the MCU.

## 4.34 Real Time Interrupt (S12SRTIV1)

### 4.34.1 Introduction

This section describes the functionality of the Real Time Interrupt module (RTI), a sub-block of the HCS12S core platform. The RTI (free running real time interrupt) enables the user to generate a hardware interrupt at a fixed periodic rate. If RTI is enabled, the interrupt occurs at the rate selected by the RTICTL and RTICNT register.

The RTI counter is clocked by the internal reference clock. At the end of the RTI timeout period the RTIF flag is set to one and a new RTI timeout period starts immediately.

The RTI contains two asynchronous clock domains (one for the Modulus Down Counter/Prescaler and one for the register bank). Information exchange between both clock domains is fully synchronized. Therefore modification of the RTI timeout period must be done in appliance to the write protection rules.

### 4.34.2 Overview

A block diagram of the RTI is shown in Figure 79

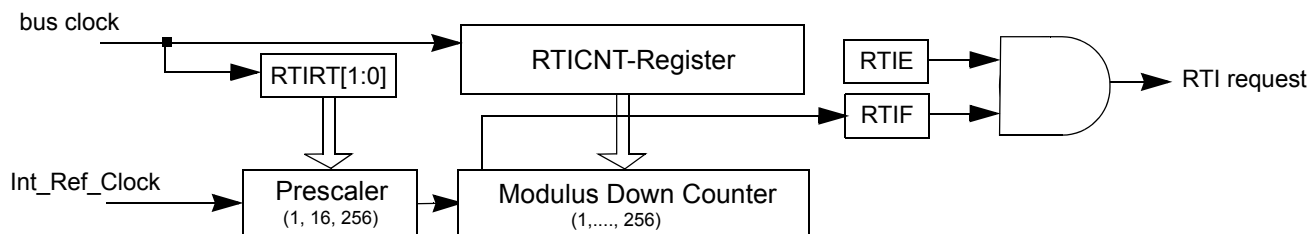

**Figure 79. Block Diagram**

### 4.34.3 Features

The RTI includes these distinctive features:

- Generate hardware interrupt at a fixed periodic rate
- Software selectable RTI operation in WAIT and STOP mode
- Software selectable RTI freeze during BDM active mode

### 4.34.4 Modes of Operation

- Run Mode  
If RTI functionality is required, the individual bits (RTIRT) of the associated rate select registers (RTICTL) have to be set to a non-zero value. In addition, to generate RTI requests, the RTI must be enabled (RTIE bit set). The RTI counter is stopped if all rate select bits in the RTICTL register are zero. Interrupt requests are disabled if the corresponding bit (RTIE) is cleared.
- Wait mode  
If the respective enable bit (RTISWAI) is cleared, the RTI continues to run, else RTI remains frozen.
- Stop mode  
If the respective enable bit (RTIRSTP) is set, the RTI continues to run, else RTI remains frozen.

### 4.34.5 External Signal Description

There are no external signals associated with this module.

### 4.34.6 Memory Map and Register

#### 4.34.6.1 Module Memory Map

A summary of the registers associated with the RTI module is shown in [Table 339](#).

**Table 339. RTI Register Summary**

Address	Name	Bit 7	6	5	4	3	2	1	Bit 0	
0x003C	RTICTL	W								
		R	RTIF	RTIFRZ	0	RTISWAI	RTIRSTP	RTIE	RTIRT1	RTIRT0
		W			WRTMASK					
0x003D	RTICNT	R	RTICNT7	RTICNT6	RTICNT5	RTICNT4	RTICNT3	RTICNT2	RTICNT1	RTICNT0
		W								

#### 4.34.6.2 Register Descriptions

This section describes in address order all the 9S12I32PIMV1 registers and their individual bits

##### 4.34.6.2.1 RTI Control Register (RTICTL)

This register controls the RTI (Real Time Interrupt).

**Table 340. RTI Control Register (RTICTL)**

0x003C								
	7	6	5	4	3	2	1	0
R	RTIF	RTIFRZ	0	RTISWAI	RTIRSTP	RTIE	RTIRT1	RTIRT0
W			WRTMASK					
Reset <sup>1</sup>	0	0	0	0	0	0	0	0

Read: Anytime

Write: Refer to each bit for individual write conditions

**Table 341. RTICTL Field Descriptions**

Field	Description
7 RTIF	<b>Real Time Interrupt Flag</b> — RTIF is set to 1 at the end of the RTI period. This flag is cleared by writing a 1. Writing a 0 has no effect. The flag cannot be set by writing a 1. If enabled (RTIE = 1), RTIF causes an interrupt request. 0 RTI time-out has not yet occurred. 1 RTI time-out has occurred.
6 RTIFRZ	<b>Real Time Interrupt Freeze</b> — RTIFRZ controls if RTI is frozen during BDM active mode Special modes: Write anytime Normal modes: Write to “1” but not to “0” 0 RTI keeps running in BDM active mode 1 RTI frozen during BDM active mode
5 WRTMASK	<b>Write Mask for RTIF, RTISWAI, RTIRSTP, RTIE and RTIRT[1:0] Bits</b> — This write-only bit serves as a mask for bit 7 and bits 4 to 0 of the RTICTL register while writing to this register. It is intended for BDM writing the RTIFRZ without touching the contents of RTIF, RTISWAI, RTIRSTP, RTIE and RTIRT[1:0] Bits. 0 Write of RTIF, RTISWAI, RTIRSTP, RTIE and RTIRT[1:0] Bits has an effect with this write of RTICTL 1 Write of RTIF, RTISWAI, RTIRSTP, RTIE and RTIRT[1:0] Bits has no effect with this write of RTICTL. (Does not count for “write once”.)
4 RTISWAI	<b>RTI Stops in Wait Mode Bit</b> Normal modes: Write once Special modes: Write anytime. 0 RTI keeps running in Wait mode. 1 RTI stops and initializes the RTI counter whenever the part enters Wait mode.
3 RTIRSTP	<b>RTI Runs in Stop Mode Bit</b> Normal modes: Write once Special modes: Write anytime. 0 RTI stops in Stop mode 1 RTI continues in Stop mode <b>Note:</b> If the RTIRSTP bit is cleared the RTI counter goes static while in Stop mode. The RTI counter does <u>not</u> initialize like in Wait mode with RTISWAI bit set.
2 RTIE	<b>Real Time Interrupt Enable Bit</b> Write anytime. 0 Interrupt requests from RTI are disabled. 1 Interrupt is requested whenever RTIF is set.
1–0 RTIRT[1:0]	<b>RTI Interrupt Prescaler Rate Select Bits</b> — These bits select the prescaler rate for the RTI. See <a href="#">Table 343.</a> , “RTI Frequency Divide Rates” for selectable ratios in conjunction with RTICNT[7:0] counter select bits Write anytime in appliance of the write protection rules (see <a href="#">4.34.7.1</a> , “RTI Register Write Protection Rules”).

**4.34.6.2.2 RTI Counter Select Bits (RTICNT)**

This register is used to restart the RTI time-out period.

**Table 342. RTICNT Register Diagram**

0x003D

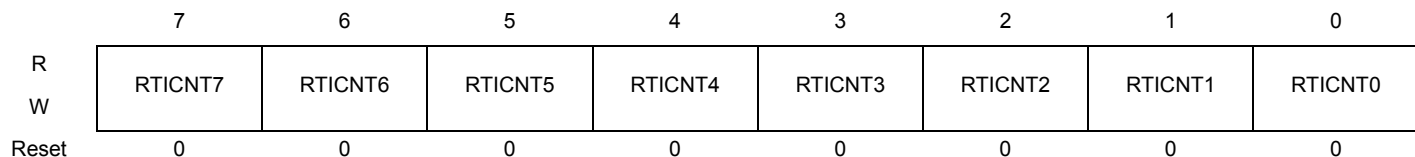

Read: Anytime

Write: Anytime in appliance of the write protection rules (see [4.34.7.1](#), “RTI Register Write Protection Rules”)

When the RTI is turned on the RTIF bit can be set with the following rates:

**Table 343. RTI Frequency Divide Rates**

RTICNT[7:0]	RTIRT[1:0] =			
	00 (OFF)	01 (1)	10 (16)	11 (256)
0000 0000 ( $\div 1$ )	OFF <sup>(189)</sup>	OFF	16	256
0000 0001 ( $\div 2$ )	OFF	2x1	2x16	2x256
0000 0010 ( $\div 3$ )	OFF	3x1	3x16	3x256
0000 0011 ( $\div 4$ )	OFF	4x1	4x16	4x256
.....	....	....	....	....
1111 1110 ( $\div 255$ )	OFF	255x1	255x16	255x256
1111 1111 ( $\div 256$ )	OFF	256x1	256x16	256x256

Note:

189. Denotes the default value out of reset. This value disables the RTI.

#### 4.34.7 Functional Description

The 9S12132PIMV1 generates a real time interrupt when the selected interrupt time period elapses. The interrupt period is selected by the RTICTL and RTICNT register (see [Table 343](#)). RTI interrupts are locally disabled by setting the RTIE bit to zero. The real time interrupt flag (RTIF) is set to 1 when a time-out occurs, and is cleared to 0 by writing a 1 to the RTIF bit.

The RTI continues to run during Stop mode if the RTIRSTP bit is set. This feature can be used for periodic wake-up from Stop if the RTI interrupt is enabled. Also the RTI continues to run during Wait mode if the RTISWAI bit is cleared. This feature can be used for periodic wake-up from Wait if the RTI interrupt is enabled. If the RTIFRZ bit of the RTICTL register is set the RTI timer is frozen during BDM active mode.

Modifying the RTI registers this way, the Frequency Divider Rate changes from OFF condition to any timeout period immediately starts the RTI counter with a full period. When the RTIRT bits are written to modify the current time-out period while the RTI counter is running the new value is loaded into the Prescaler at the end of the current time-out period. Also when the RTICNT register gets modified while the RTI counter is running the new RTICNT values are loaded into the Modulus Down Counter at the end of the current RTI period. Hence, frequent modification of the RTIRT bits and RTICNT register faster than the actual selected time-out period results in ignored values and only the value available at current time-out is loaded for the next timeout period.

The RTI Modulus Down Counter and Prescaler are clocked by the internal reference clock other than the RTI registers which are clocked with the internal bus clock. Both clocks are asynchronous and information exchange between these two clock domains is synchronized. Refer to the SoC Guide for more information regarding these clocks and see [4.34.7.1, "RTI Register Write Protection Rules"](#) and [4.34.7.2, "Modification of Prescaler rate \(RTIRT bits\)"](#) and [4.34.7.3, "Modification of Modulus Down Counter Rate \(RTICNT register\)"](#) for RTI register access rules.

##### 4.34.7.1 RTI Register Write Protection Rules

As mentioned, the RTI registers and RTI counter are running on two different asynchronous clock domains. Therefore there is a synchronization delay when modifying the registers with regard to time-out period until the modification takes effect. The synchronization delay is typically three clock cycles on the counter clock domain and two clock cycles on the register clock domain. This means it takes three cycles in the clock domain of the RTI counter (internal reference clock) to receive the modified time-out values and two cycles in the RTI register clock domain (bus clock) to receive the time-out flag from the counter in the register. Also a write access to the RTICNT register locks this register and a write access to the RTICTL register locks the RTIRT bits against further write accesses for three internal reference clock cycles plus two bus clock cycles after the write access occurred, which is due to synchronization. Therefore modifying the RTICNT register or RTIRT bits faster than they are synchronized results in ignored values.

In general it should be avoided to access both registers in a single word access if only one of the registers should be modified.

### 4.34.7.2 Modification of Prescaler rate (RTIRT bits)

Applications which modify the Frequency Divider Rate by modifying the RTIRT bits (Prescaler rate) in the RTICTL register should follow below recommendations.

If the Frequency Divider Rate is set lower or equal to three the RTI interrupt service routine accesses the RTICTL register with in a timing window which is less or equal the synchronization delay. Hence the interrupt service routine accessing the RTICTL register to clear the RTIF bit is executed with such frequency, the RTIRT bits are permanently locked. Therefore the following sequence is recommended if RTIRT bits should be changed for a current selected Frequency Divider Rate of two or three:

- Access the RTICTL register to clear the RTI interrupt flag (RTIF bit) and disable the RTI interrupt (clear RTIE bit) by a single write access.
- Execute a software loop in which the RTICTL register is written to modify the RTIRT bits until the new Frequency Divider Rate is taken (read back value of RTIRT bits equals new value)
- Access RTICTL register to enable RTI interrupts again.

If the actual Frequency Divider Rate of the RTI is set to a rate higher than three the write access to clear the interrupt flag (RTIF bit) in the RTICTL register can be used to modify the RTIRT bits of the RTICTL register.

### 4.34.7.3 Modification of Modulus Down Counter Rate (RTICNT register)

Applications which frequently access the RTICNT register should follow below recommendations. If the RTICNT register is accessed with in a timing window which is less or equal the synchronization delay the following sequence is recommended:

- Access the RTICTL register to clear the RTI interrupt flag (RTIF bit) and disable the RTI interrupt (clear RTIE bit) by a single write access.
- Execute a software loop in which the RTICNT register is written to modify the rate until the new Frequency Divider Rate is taken (read back value of RTICNT bits equals new value)
- Access RTICTL register to enable RTI interrupts again.

If the RTICNT register is accessed in a timing window which is higher than the synchronization delay, only the RTICNT register needs to be written and wait until next time-out occurs.

## 4.35 Computer Operating Properly (S12SCOPV1)

### 4.35.1 Introduction

This section describes the functionality of the Computer Operating Properly module (COP), a sub-block of the HCS12S core platform. The COP (free running watchdog timer) enables the user to check that a program is running and sequencing properly. If the COP times out a system reset is initiated. Two types of COP operation are available: Window COP or Normal COP

When COP is enabled, sequential writes of \$55 and \$AA (in this order) are expected to the ARMCOP register during the selected timeout period. Once this is done, the COP timeout period restarts. If the program fails to do this the S12SCOP initiates a reset.

#### 4.35.1.1 Overview

A block diagram of the COP is shown in [Figure 79](#)

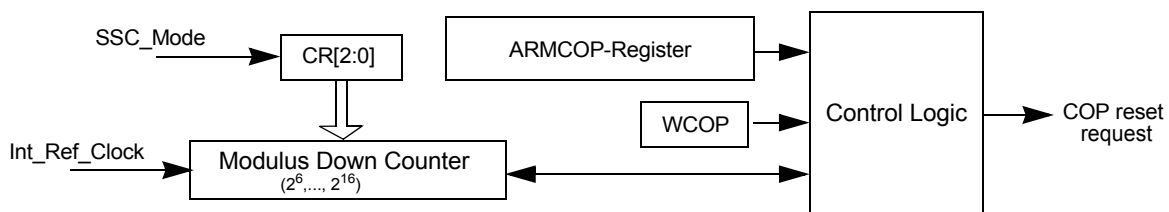

**Figure 80. Block Diagram**

### 4.35.1.2 Features

The COP includes these distinctive features:

- Watchdog timer with a timeout clear window.
- Default maximum COP rate and no Window COP in Special Single Chip mode after system reset.
- Auto COP rate load after system reset in SoC Normal mode. (For source of COP rate bits refer to the Device User Guide)
- Software selectable COP operation in WAIT and STOP mode.
- Customer selectable COP off while BDM active (debugging session).

### 4.35.1.3 Modes of Operation

- Run mode  
If COP functionality is required, the individual bits of the associated rate select registers (COPCTL) have to be set to a non-zero value. The COP is stopped if all rate select bits are zero.
- Wait mode  
If the respective enable bit (COPSWAI) is cleared, the COP continues to run, else COP remains frozen.
- Stop mode  
If the respective enable bit (COPRSTP) is set, the COP continues to run, else COP remains frozen.

### 4.35.2 External Signal Description

There are no external signals associated with this module.

### 4.35.3 Memory Map and Register

#### 4.35.3.1 Module Memory Map

A summary of the registers associated with the COP module is shown in [Table 339](#).

**Table 344. COP Register Summary**

Address	Name		Bit 7	6	5	4	3	2	1	Bit 0
0x003E	COPCTL	R	WCOP	RSBCK	0	COPSWAI	COPRSTP	CR2	CR1	CR0
		W			WRTMASK					
0x003F	ARMCOP	R	0	0	0	0	0	0	0	0
		W	Bit 7	Bit 6	Bit 5	Bit 4	Bit 3	Bit 2	Bit 1	Bit 0

#### 4.35.3.2 Register Descriptions

This section describes in address order all the S12SCOP registers and their individual bits

### 4.35.3.2.1 COP Control Register (COPCTL)

This register controls the COP (Computer Operating Properly) watchdog.

**Table 345. COP Control Register (COPCTL)**

0x003E		7	6	5	4	3	2	1	0
R		WCOP	RSBCK	0	COPSWAI	COPRSTP	CR2	CR1	CR0
W				WRTMASK					
Reset <sup>(190)</sup>		see note	0	0	0	0	see note	see note	see note

Note:

190. Refer to Device User Guide (Section 4.35.4.1, "COP Configuration") for reset values of WCOP, CR2, CR1 and CR0.

Read: Anytime

Write:

1. RSBCK: anytime in special modes; write to "1" but not to "0" in all other modes
2. WCOP, CR2, CR1, CR0:
  - Anytime in special modes
  - Write once in all other modes
    - Writing CR[2:0] to "000" has no effect, but counts for the "write once" condition.
    - Writing WCOP to "0" has no effect, but counts for the "write once" condition.

The COP timeout period is restarted if one these two conditions are true:

1. Writing a non-zero value to CR[2:0] (anytime in special modes, once in all other modes) with WRTMASK = 0.
- or
2. Changing RSBCK bit from "0" to "1".

**Table 346. COPCTL Field Descriptions**

Field	Description
7 WCOP	<b>Window COP Mode Bit</b> — When set, a write to the ARM COP register must occur in the last 25% of the selected period. A write during the first 75% of the selected period resets the part. As long as all writes occur during this window, \$55 can be written as often as desired. Once \$AA is written after the \$55, the timeout logic restarts and the user must wait until the next window before writing to ARM COP. <a href="#">Table 347</a> shows the duration of this window for the seven available COP rates. 0 Normal COP operation 1 Window COP operation
6 RSBCK	<b>COP and RTI Stop in Active BDM Mode Bit</b> 0 Allows the COP and RTI to keep running in Active BDM mode. 1 Stops the COP and RTI counters whenever the part is in Active BDM mode.
5 WRTMASK	<b>Write Mask for WCOP and CR[2:0] Bit</b> — This write-only bit serves as a mask for the WCOP, CR[2:0], COPSWAI and COPRSTP bits while writing the COPCTL register. It is intended for BDM writing the RSBCK without touching the contents of WCOP, CR[2:0], COPSWAI, and COPRSTP. 0 Write of WCOP, CR[2:0], COPSWAI and COPRSTP has an effect with this write of COPCTL 1 Write of WCOP, CR[2:0], COPSWAI and COPRSTP has no effect with this write of COPCTL. (Does not count for "write once")
4 COPSWAI	<b>COP Stops in Wait mode bit</b> Normal modes: Write once Special modes: Write anytime 0 COP continues in Wait mode. 1 COP stops and initializes the COP counter whenever the part enters Wait mode.

**Table 346. COPCTL Field Descriptions (continued)**

Field	Description
3 COPRSTP	<b>COP Runs in Stop Mode Bit</b> Normal modes: Write once Special modes: Write anytime 0 COP stops in Stop mode 1 COP continues in Stop mode <b>Note:</b> If the COPRSTP bit is cleared the COP counter goes static while in Stop mode. The COP counter does <u>not</u> initialize like in Wait mode with COPSWAI bit set.
2-0 CR[2:0]	<b>COP Watchdog Timer Rate Select Bits</b> — These bits select the COP timeout rate (see <a href="#">Table 347</a> ). Writing a non-zero value to CR[2:0] enables the COP counter and starts the timeout period. A COP counter timeout causes a system reset. This can be avoided by periodically (before timeout) re-initialize the COP counter via the ARMCOP register. While all of the following four conditions are true the CR[2:0], WCOP bits are ignored and the COP operates at highest timeout period ( $2^{16}$ cycles) in normal COP mode (Window COP mode disabled): 1) COP is enabled (CR[2:0] is not 000) 2) BDM mode active 3) RSBCK = 0 4) Operation in special mode

**Table 347. COP Watchdog Rates<sup>(191)</sup>**

CR2	CR1	CR0	Input_CLK Cycles to Timeout
0	0	0	COP disabled
0	0	1	$2^6$
0	1	0	$2^8$
0	1	1	$2^{10}$
1	0	0	$2^{12}$
1	0	1	$2^{14}$
1	1	0	$2^{15}$
1	1	1	$2^{16}$

Note:

191. Refer to Device User Guide ([Section 4.35.4.1, "COP Configuration"](#)) for reset values of WCOP, CR2, CR1 and CR0.

#### 4.35.3.2.2 COP Timer Arm/Reset Register (ARMCOP)

This register is used to restart the COP timeout period.

**Table 348. ARMCOP Register Diagram**

0x003F

	7	6	5	4	3	2	1	0
R	0	0	0	0	0	0	0	0
W	Bit 7	Bit 6	Bit 5	Bit 4	Bit 3	Bit 2	Bit 1	Bit 0
Reset	0	0	0	0	0	0	0	0

Read: Always reads \$00

Write: Anytime

- When the COP is disabled (CR[2:0] = “000”), writing to this register has no effect.
- When the COP is enabled by setting CR[2:0] non-zero, the following applies:
- Writing any value other than \$55 or \$AA causes a COP reset. To restart the COP timeout period, you must write \$55 followed by a write of \$AA. Other instructions may be executed between these writes, but the sequence (\$55, \$AA) must be completed prior to the COP end of timeout period to avoid a COP reset. Sequences of \$55 writes or sequences of \$AA writes are allowed if the WCOP bit is not set. When the WCOP bit is set, \$55 and \$AA writes must be done in the last 25% of the selected timeout period. Writing any value in the first 75% of the selected period causes a COP reset. Only sequences of \$55 are allowed if the WCOP bit is set.

**4.35.4 Functional Description**

The COP (free running watchdog timer) enables the user to check that a program is running and sequencing properly. When the COP is being used, software is responsible for keeping the COP from timing out. If the COP times out, it is an indication the software is no longer being executed in the intended sequence; thus a system reset is initiated. The COP runs on the CRG internal reference clock. Three control bits in the COPCTL register allow a selection of seven COP timeout periods.

When COP is enabled, the program must write \$55 and \$AA (in this order) to the ARMCOP register during the selected timeout period. Once this is done, the COP timeout period is restarted. If the program fails to do this and the COP times out, the part resets. Also, if any value other than \$55 or \$AA is written, the part is immediately reset. Sequences of \$55 writes or sequences of \$AA writes are allowed if the WCOP bit is not set.

The window COP operation is enabled by setting WCOP in the COPCTL register. When the WCOP bit is set while COP is enabled, a write to the ARMCOP register must occur in the last 25% of the selected period. A premature write immediately resets the part. As long as all writes occur during the 25% window, \$55 can be written as often as desired. Once \$AA is written after the \$55, the timeout logic restarts, and the user must wait until the next window before writing to the ARMCOP register.

If the COPRSTP bit is set, the COP continues to run in Stop mode. The COP continues to run during Wait mode if the COPSWAI bit is cleared.

**4.35.4.1 COP Configuration**

**NOTE**

If the MCU is secured and being started in special single chip mode, the COP timeout rate is always set to the longest period (CR[2:0] = 111) after COP reset.

The COP timeout rate bits CR[2:0] and the WCOP bit in the COPCTL register are loaded on rising edge of RESET from the Flash register FOPT. See Table 349 and Table 350 for coding. The FOPT register is loaded from the Flash configuration field byte at the global address \$03\_FF0E during the reset sequence.

**Table 349. Initial COP Rate Configuration**

NV[2:0] in FCTL Register	CR[2:0] in COPCTL Register
000	111
001	110
010	101
011	100
100	011
101	010
110	001
111	000

**Table 350. Initial WCOP Configuration**

NV[3] in FCTL Register	WCOP in COPCTL Register
1	0
0	1

## 4.36 32 kbyte Flash Module (S12SFTSR32KV1)

### 4.36.1 Introduction

This document describes the S12SFTSR32K module, which includes a 32 kbyte Flash (nonvolatile) memory.

#### CAUTION

A Flash block address must be in the erased state before being programmed. Cumulative programming of bits within a Flash block address is not allowed, except for status field updates required in EEPROM emulation applications.

The Flash memory is ideal for single-supply applications, allowing for field reprogramming without requiring external high voltage sources for program or erase operations. The Flash module includes a memory controller which executes commands to modify Flash memory contents.

Array read access time is one bus cycle for bytes and aligned words, and two bus cycles for misaligned words. For Flash memory, an erased bit reads 1 and a programmed bit reads 0. It is not possible to read from a Flash block while any command is executing on a specific Flash block.

#### 4.36.1.1 Glossary

**Command Write Sequence** — A three step MCU instruction sequence to execute built-in algorithms (including program and erase) on the Flash memory.

**Flash Array** — The Flash array constitutes the main memory portion of a Flash block.

**Flash Block** — An analog block consisting of the Flash array and Flash IFR with supporting high voltage and parametric test circuitry.

**Flash IFR** — Nonvolatile information memory, consisting of 128 bytes, located in the Flash block outside of Flash main memory. Refer to the SoC Guide on how to make the Flash IFR visible in the global memory map.

#### 4.36.1.2 Features

- 32 kbytes of Flash memory comprised of one 32 kbyte block divided into 64 sectors of 512 bytes
- Nonvolatile information memory (Flash IFR) comprised of one 128 byte block
- Automated program and erase algorithm
- Interrupt on Flash command completion, command buffer empty
- Fast program and sector erase operation
- Burst program command for faster Flash array program times
- Flexible protection scheme to prevent accidental program or erase
- Single power supply for all Flash operations including program and erase
- Security feature to prevent unauthorized access to the Flash memory

**4.36.1.3 Block Diagram**

A block diagram of the Flash module is shown in [Figure 81](#).

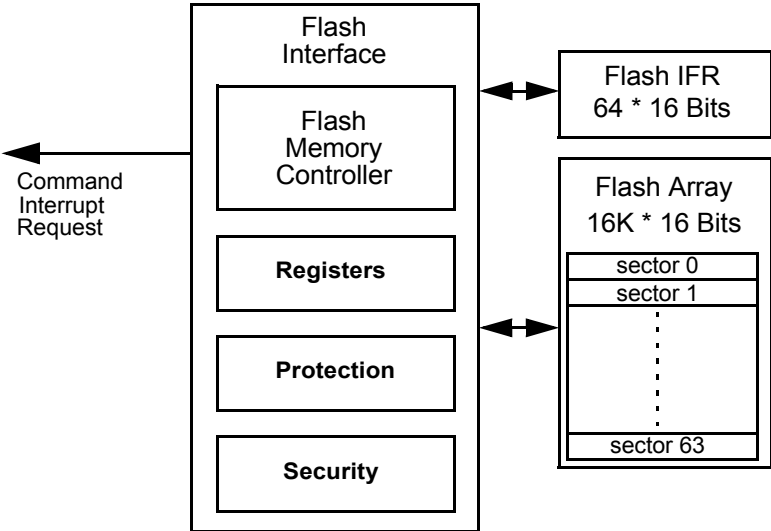

**Figure 81. S12SFTSR32K Block Diagram**

**4.36.2 External Signal Description**

The Flash module has no external signals.

**4.36.3 Memory Map and Register Definition**

This section describes the Flash array map, Flash IFR map, and Flash register map shown in [Figure 82](#).

**4.36.3.1 Flash Array Map**

The MCU memory map places the Flash array addresses between Flash array base + 0x0000 and 0x7FFF.

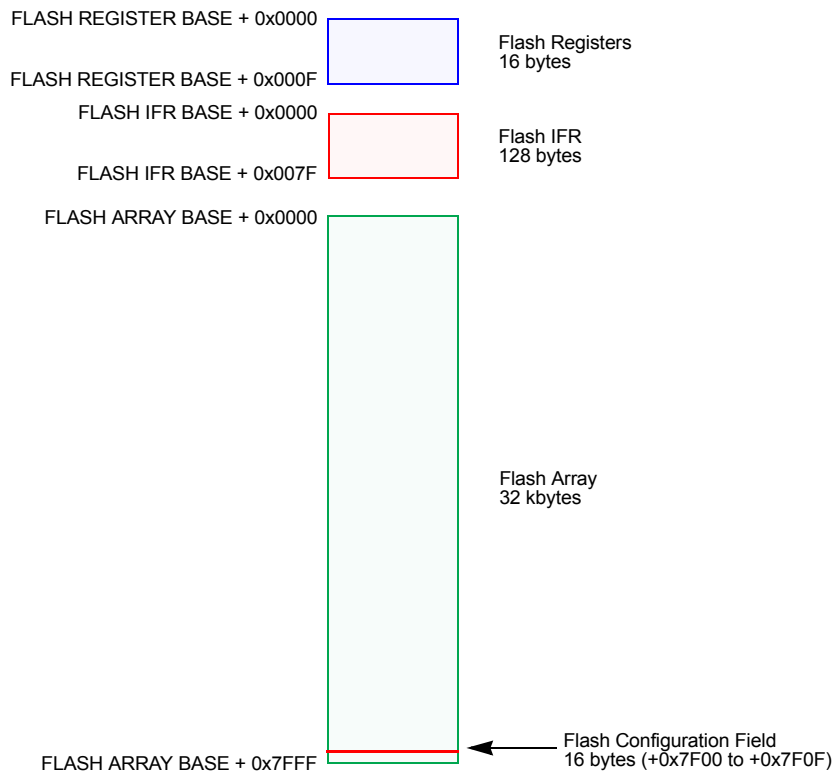

Figure 82. Flash Memory Map

4.36.3.1.1 Flash Configuration Field Description

During the reset sequence, the contents of the 16 byte Flash configuration field are read to set Flash memory protection and Flash security features. The Flash configuration field starts at Flash array base + 0x7F00, as shown in Table 351.

Table 351. Flash Configuration Field

Address Relative to Flash Array Base	Size (bytes)	Description
0x7F00 - 0x7F07	8	Backdoor Key Refer to Section 4.36.6.1, "Unsecuring the MCU Using Backdoor Key Access"
0x7F08 - 0x7F0C	5	Reserved
0x7F0D	1	Flash Protection byte Refer to Section 4.36.3.3.5, "Flash Protection Register (FPROT)"
0x7F0E	1	Flash Nonvolatile byte Refer to the Section 4.36.3.4.9, "Flash Option Register (FOPT)"
0x7F0F	1	Flash Security byte Refer to Section 4.36.3.3.2, "Flash Security Register (FSEC)"

### 4.36.3.2 Flash IFR Map

The Flash IFR is a 128 byte nonvolatile information memory which is read accessible as defined in the SoC Guide. The MCU memory map places the Flash IFR addresses between Flash IFR base + 0x0000 and 0x007F as shown in [Table 352](#).

**Table 352. Flash IFR Description**

Address Relative to Flash IFR Base <sup>(192)</sup>	Size (bytes)	Description
0x0000 - 0x000D	14	Wafer lot number, wafer number, X coordinate, Y coordinate
0x000E - 0x003F	50	Reserved for wafer test data
0x0040 - 0x004F	16	Flash memory controller parameters
0x0050 - 0x007B	44	Reserved
0x007C - 0x007F	4	MCU control parameters

Note:

192. Refer to the SoC Guide for details on how to enable the Flash IFR

### 4.36.3.3 Register Descriptions

The Flash module contains a set of 16 control and status registers located between Flash register base + 0x0000 and 0x000F. Flash registers are byte and word accessible. A summary of the Flash module registers is given in [Table 353](#). Detailed descriptions of each register bit are provided in the following sections.

**Table 353. S12SFTSR32K Register Summary (Normal/Special Mode)**

Register Name		Bit 7	6	5	4	3	2	1	Bit 0
0x0100 FCLKDIV	R	FDIVLD	PRDIV8	FDIV5	FDIV4	FDIV3	FDIV2	FDIV1	FDIV0
	W								
0x0101 FSEC	R	KEYEN1	KEYEN0	0	0	0	0	SEC1	SEC0
	W								
0x0102 FRSV0	R	0	0	0	0	0	0	0	0
	W								
0x0103 FCNFG	R				0	0	0	0	0
	W	CBEIE	CCIE	KEYACC					
0x0104 FPROT	R								
	W	FPHS4	FPHS3	FPHS2	FPHS1	FPHS0	FPLS2	FPLS1	FPLS0
0x0105 FSTAT	R		CCIF			0	BLANK	0	0
	W	CBEIF		PVIOL	ACCERR				
0x0106 FCMD	R	0							
	W		CMDB6	CMDB5	CMDB4	CMDB3	CMDB2	CMDB1	CMDB0
0x0107 FRSV1	R	0	0	0	0	0	0	0	0
	W								
0x0108 FADDRHI	R	0	0	0	0	0	0	0	0
	W			FAB13	FAB12	FAB11	FAB10	FAB9	FAB8
0x0109 FADDRLO	R	0	0	0	0	0	0	0	0
	W	FAB7	FAB6	FAB5	FAB4	FAB3	FAB2	FAB1	FAB0

**Table 353. S12SFTSR32K Register Summary (Normal/Special Mode) (continued)**

Register Name	Bit 7	6	5	4	3	2	1	Bit 0	
0x010A FDATAHI	R	FD15	FD14	FD13	FD12	FD11	FD10	FD9	FD8
	W								
0x010B FDATALO	R	FD7	FD6	FD5	FD4	FD3	FD2	FD1	FD0
	W								
0x010C FRSV2	R	0	0	0	0	0	0	0	0
	W								
0x010D FRSV3	R	0	0	0	0	0	0	0	0
	W								
0x010E FRSV4	R	0	0	0	0	0	0	0	0
	W								
0x010F FRSV5	R	0	0	0	0	0	0	0	0
	W								

#### 4.36.3.3.1 Flash Clock Divider Register (FCLKDIV)

The FCLKDIV register is used to control the length of timed events in program and erase algorithms executed by the Flash memory controller.

**Table 354. Flash Clock Divider Register (FCLKDIV)**

		7	6	5	4	3	2	1	0
R W		FDIVLD	PRDIV8	FDIV[5:0]					
	Reset								

All bits in the FCLKDIV register are readable and writable with restrictions, as determined by the value of FDIVLD when writing to the FCLKDIV register (see Table 355).

**Table 355. FCLKDIV Field Descriptions**

Field	Description
7 FDIVLD	<b>Clock Divider Load Control</b> — When writing to the FCLKDIV register for the first time after a reset, the value of the FDIVLD bit written controls the future ability to write to the FCLKDIV register: 0 Writing a 0 to FDIVLD locks the FCLKDIV register contents; all future writes to FCLKDIV are ignored. 1 Writing a 1 to FDIVLD keeps the FCLKDIV register writable; next write to FCLKDIV is allowed. When reading the FCLKDIV register, the value of the FDIVLD bit read indicates the following: 0 FCLKDIV register has not been written to since the last reset. 1 FCLKDIV register has been written to since the last reset.
6 PRDIV8	<b>Enable Prescaler by 8.</b> 0 The bus clock is directly fed into the clock divider. 1 The bus clock is divided by 8 before feeding into the clock divider.
5:0 FDIV[5:0]	<b>Clock Divider Bits</b> — The combination of PRDIV8 and FDIV[5:0] must divide the bus clock down to a frequency of 150 to 200 kHz. The minimum divide ratio is 2 (PRDIV8 = 0, FDIV = 0x01) and the maximum divide ratio is 512 (PRDIV8 = 1, FDIV = 0x3F). Refer to Section 4.36.4.1.1, "Writing the FCLKDIV Register" for more information.

**4.36.3.3.2 Flash Security Register (FSEC)**

The FSEC register holds all bits associated with the security of the MCU and Flash module.

**Table 356. Flash Security Register (FSEC)**

0x0101

	7	6	5	4	3	2	1	0
R	KEYEN[1:0]		0	0	0	0	SEC[1:0]	
W								
Reset	F	F	0	0	0	0	F	F

All bits in the FSEC register are readable but are not writable.

The FSEC register is loaded from the Flash configuration field (see [Section 4.36.3.1.1](#)) during the reset sequence, indicated by F in [Table 356](#).

**Table 357. FSEC Field Descriptions**

Field	Description
7:6 KEYEN[1:0]	<b>Backdoor Key Security Enable Bits</b> — The KEYEN[1:0] bits define the enabling of backdoor key access to the Flash module as shown in <a href="#">Table 358</a> .
1:0 SEC[1:0]	<b>Flash Security Bits</b> — The SEC[1:0] bits define the security state of the MCU as shown in <a href="#">Table 359</a> . If the Flash module is unsecured using backdoor key access, the SEC[1:0] bits are forced to the unsecured state.

**Table 358. Flash KEYEN States**

KEYEN[1:0]	Status of Backdoor Key Access
00	DISABLED
01 <sup>(193)</sup>	DISABLED
10	ENABLED
11	DISABLED

Note:

193. Preferred KEYEN state to disable Backdoor Key Access.

**Table 359. Flash Security States**

SEC[1:0]	Status of Security
00	SECURED
01 <sup>(194)</sup>	SECURED
10	UNSECURED

Note:

194. Preferred SEC state to set MCU to secured state.

The security feature in the Flash module is described in [Section 4.36.6, "Flash Module Security"](#).

### 4.36.3.3.3 Flash Reserved0 Register (FRSV0)

The FRSV0 register is reserved for factory testing.

**Table 360. Flash Reserved0 Register (FRSV0)**

0x0102

	7	6	5	4	3	2	1	0
R	0	0	0	0	0	0	0	0
W								
Reset	0	0	0	0	0	0	0	0

All bits in the FRSV0 register read 0 and are not writable.

### 4.36.3.3.4 Flash Configuration Register (FCNFG)

**NOTE**

Flash array reads are allowed while KEYACC is set.

The FCNFG register enables the Flash interrupts and gates the security backdoor writes.

**Table 361. Flash Configuration Register (FCNFG)**

0x0103

	7	6	5	4	3	2	1	0
R	CBEIE	CCIE	KEYACC	0	0	0	0	0
W								
Reset	0	0	0	0	0	0	0	0

CBEIE, CCIE, and KEYACC bits are readable and writable, while all remaining bits read 0 and are not writable. KEYACC is only writable if KEYEN is set to the enabled state (see [Section 4.36.3.3.2, "Flash Security Register \(FSEC\)"](#)).

**Table 362. FCNFG Field Descriptions**

Field	Description
7 CBEIE	<b>Command Buffer Empty Interrupt Enable</b> — The CBEIE bit enables an interrupt in case of an empty command buffer in the Flash module. 0 Command buffer empty interrupt disabled. 1 An interrupt is requested whenever the CBEIF flag (see <a href="#">Section 4.36.3.4, "Flash Status Register (FSTAT)"</a> ) is set.
6 CCIE	<b>Command Complete Interrupt Enable</b> — The CCIE bit enables an interrupt in case all commands have been completed in the Flash module. 0 Command complete interrupt disabled. 1 An interrupt is requested whenever the CCIF flag (see <a href="#">Section 4.36.3.4, "Flash Status Register (FSTAT)"</a> ) is set.
5 KEYACC	Enable Security Key Writing 0 Writes to the Flash block are interpreted as the start of a command write sequence. 1 Writes to the Flash block are interpreted as keys to open the backdoor.

**4.36.3.3.5 Flash Protection Register (FPROT)**

The FPROT register defines which Flash sectors are protected against program or erase operations.

**Table 363. Flash Protection Register (FPROT)**

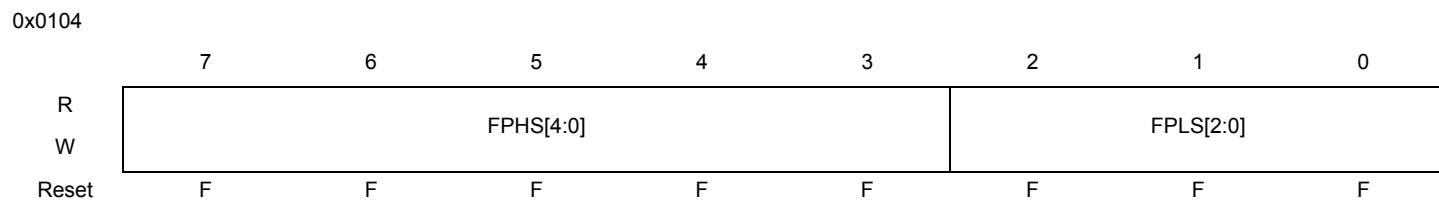

In Normal mode, FPROT bits are readable and writable as long as the size of the protected Flash memory is being increased. Any write to FPROT attempting to decrease the size of the protected Flash memory is ignored. In special mode, FPROT bits are readable and writable without restrictions.

During the reset sequence, the FPROT register is loaded from the Flash protection byte in the Flash configuration field (see Section 4.36.3.1.1). To change the Flash protection loaded during the reset sequence, the Flash sector containing the Flash configuration field must be unprotected, then the Flash protection byte must be reprogrammed.

Trying to alter data in any protected area in the Flash memory results in a protection violation error, and the PVIOL flag is set in the FSTAT register. The mass erase of the Flash array is not possible if any of the Flash sectors contained in the Flash array are protected.

**Table 364. FPROT Field Descriptions**

Field	Description
7:3 FPHS[4:0]	<b>Flash Protection Higher Address Size</b> — The FPHS bits determine the size of the protected higher Flash address range as shown in Table 365.
2:0 FPLS[2:0]	<b>Flash Protection Lower Address Size</b> — The FPLS bits determine the size of the protected lower Flash address range as shown in Table 366.

**Table 365. Flash Protection Higher Address Range**

FPHS[4:0]	Protected Address Range Relative to Flash Array Base	Protected Size
0x00	0x0400–0x7FFF	31 kbytes
0x01	0x0800–0x7FFF	30 kbytes
0x02	0x0C00–0x7FFF	29 kbytes
0x03	0x1000–0x7FFF	28 kbytes
0x04	0x1400–0x7FFF	27 kbytes
0x05	0x1800–0x7FFF	26 kbytes
0x06	0x1C00–0x7FFF	25 kbytes
0x07	0x2000–0x7FFF	24 kbytes
0x08	0x2400–0x7FFF	23 kbytes
0x09	0x2800–0x7FFF	22 kbytes
0x0A	0x2C00–0x7FFF	21 kbytes
0x0B	0x3000–0x7FFF	20 kbytes
0x0C	0x3400–0x7FFF	19 kbytes

**Table 365. Flash Protection Higher Address Range (continued)**

FPHS[4:0]	Protected Address Range Relative to Flash Array Base	Protected Size
0x0D	0x3800–0x7FFF	18 kbytes
0x0E	0x3C00–0x7FFF	17 kbytes
0x0F	0x4000–0x7FFF	16 kbytes
0x10	0x4400–0x7FFF	15 kbytes
0x11	0x4800–0x7FFF	14 kbytes
0x12	0x4C00–0x7FFF	13 bytes
0x13	0x5000–0x7FFF	12 bytes
0x14	0x5400–0x7FFF	11 bytes
0x15	0x5800–0x7FFF	10 bytes
0x16	0x5C00–0x7FFF	9.0 kbytes
0x17	0x6000–0x7FFF	8.0 kbytes
0x18	0x6400–0x7FFF	7.0 kbytes
0x19	0x6800–0x7FFF	6.0 kbytes
0x1A	0x6C00–0x7FFF	5.0 kbytes
0x1B	0x7000–0x7FFF	4.0 kbytes
0x1C	0x7400–0x7FFF	3.0 kbytes
0x1D	0x7800–0x7FFF	2.0 kbytes
0x1E	0x7C00–0x7FFF	1.0 kbyte
0x1F	No Higher Protection	0 kbytes

**Table 366. Flash Protection Lower Address Range**

FPLS[2:0]	Protected Address Range Relative to Flash Array Base	Protected Size
000	0x0000–0x7FFF	32 kbytes <sup>(195)</sup>
001 <sup>(196)</sup>	<sup>(196)</sup>	<sup>(196)</sup>
010 <sup>(196)</sup>	<sup>(196)</sup>	<sup>(196)</sup>
011	0x0000–0x0FFF	4.0 kbytes
100	0x0000–0x0BFF	3.0 kbytes
101	0x0000–0x07FF	2.0 kbytes
110	0x0000–0x03FF	1.0 kbyte
111	No Lower Protection	0 kbytes

Note:

195. Flash memory fully protected.

196. Reserved for future use. If written, these FPLS values is treated the same as FPLS = 000.

### 4.36.3.4 Flash Status Register (FSTAT)

The FSTAT register defines the operational status of the Flash module.

**Table 367. Flash Status Register (FSTAT - Normal Mode)**

0x0105

	7	6	5	4	3	2	1	0
R	CBEIF	CCIF	PVIOL	ACCERR	0	BLANK	0	0
W								
Reset	1	1	0	0	0	0	0	0

**Table 368. Flash Status Register (FSTAT - Special Mode)**

0x0105

	7	6	5	4	3	2	1	0
R	CBEIF	CCIF	PVIOL	ACCERR	0	BLANK	FAIL	0
W								
Reset	1	1	0	0	0	0	0	0

In normal mode, CCIF, PVIOL, and ACCERR are readable and writable. CCIF and BLANK are readable and not writable. The remaining bits read 0 and are not writable. In special mode, BLANK and FAIL are readable and writable. FAIL must be clear when starting a command write sequence.

**Table 369. FSTAT Field Descriptions**

Field	Description
7 CBEIF	<b>Command Buffer Empty Interrupt Flag</b> — The CBEIF flag indicates the command buffer is empty so a new command write sequence can be started when performing burst programming. Writing a 0 to the CBEIF flag has no effect on CBEIF. Writing a 0 to CBEIF after writing an aligned address to the Flash array memory, but before CBEIF is cleared, aborts a command write sequence and cause the ACCERR flag to be set. Writing a 0 to CBEIF outside of a command write sequence does not set the ACCERR flag. The CBEIF flag is cleared by writing a 1 to CBEIF. The CBEIF flag is used together with the CBEIE bit in the FCNFG register to generate an interrupt request (see <a href="#">Figure 90</a> ). 0 Command buffers are full. 1 Command buffers are ready to accept a new command.
6 CCIF	<b>Command Complete Interrupt Flag</b> — The CCIF flag indicates there are no more commands pending. The CCIF flag is cleared when CBEIF is cleared and sets automatically upon completion of all active and pending commands. The CCIF flag does not set when an active program command completes, and a pending burst program command is fetched from the command buffer. Writing to the CCIF flag has no effect on CCIF. The CCIF flag is used together with the CCIE bit in the FCNFG register to generate an interrupt request (see <a href="#">Figure 90</a> ). 0 Command in progress. 1 All commands are completed.
5 PVIOL	<b>Protection Violation Flag</b> —The PVIOL flag indicates an attempt was made to program or erase an address in a protected area of the Flash memory or Flash IFR during a command write sequence. Writing a 0 to the PVIOL flag has no effect on PVIOL. The PVIOL flag is cleared by writing a 1 to PVIOL. While PVIOL is set, it is not possible to launch a command or start a command write sequence. 0 No protection violation detected. 1 Protection violation has occurred.
4 ACCERR	<b>Access Error Flag</b> — The ACCERR flag indicates an illegal access has occurred to the Flash memory or Flash IFR, caused by either a violation of the command write sequence (see <a href="#">Section 4.36.4.1.2, "Command Write Sequence"</a> ), issuing an illegal Flash command (see <a href="#">Table 372</a> ), or the execution of a CPU STOP instruction while a command is executing (CCIF = 0). Writing a 0 to the ACCERR flag has no effect on ACCERR. The ACCERR flag is cleared by writing a 1 to ACCERR. While ACCERR is set, it is not possible to launch a command or start a command write sequence. 0 No access error detected. 1 Access error has occurred.

**Table 369. FSTAT Field Descriptions (continued)**

Field	Description
2 BLANK	<b>Flag Indicating the Erase Verify Operation Status</b> — When the CCIF flag is set after completion of an erase verify command, the BLANK flag indicates the result of the erase verify operation. The BLANK flag is cleared by the Flash module when CBEIF is cleared as part of a new valid command write sequence. Writing to the BLANK flag has no effect on BLANK except in special mode where the BLANK flag can be cleared by writing a 1 to BLANK. 0 Flash block verified as not erased. 1 Flash block verified as erased.
1 FAIL	<b>Flag Indicating a Failed Flash Operation</b> — The FAIL flag sets if the erase verify operation fails (Flash block verified as not erased). Writing a 0 to the FAIL flag has no effect on FAIL. The FAIL flag is cleared by writing a 1 to FAIL. 0 Flash operation completed without error. 1 Flash operation failed.

#### 4.36.3.4.1 Flash Command Register (FCMD)

The FCMD register is the Flash command register.

**Table 370. Flash Command Register (FCMD)**

0x0106

	7	6	5	4	3	2	1	0
R	0	CMDB[6:0]						
W								
Reset	0	0	0	0	0	0	0	0

All CMDB bits are readable and writable during a command write sequence while bit 7 reads 0 and is not writable.

**Table 371. FCMD Field Descriptions**

Field	Description
6:0 CMDB[6:0]	<b>Flash Command</b> — Valid Flash commands in normal mode are shown in <a href="#">Table 372</a> . Writing any command other than those listed in <a href="#">Table 372</a> in normal mode sets the ACCERR flag in the FSTAT register.

**Table 372. Valid Flash Command List**

CMDB[6:0]	NVM Command
0x05	Erase Verify
0x20	Program
0x25	Burst Program
0x40	Sector Erase
0x41	Mass Erase

**4.36.3.4.2 Flash Reserved1 Register (FRSV1)**

The FRSV1 register is reserved for factory testing.

**Table 373. Flash Reserved1 Register (FRSV1)**

0x0107

	7	6	5	4	3	2	1	0
R	0	0	0	0	0	0	0	0
W								
Reset	0	0	0	0	0	0	0	0

All FRSV1 bits read 0 and are not writable.

**4.36.3.4.3 Flash Address Registers (FADDR)**

**NOTE**

The LSB of the MCU global address is not stored in the FADDR registers, since the Flash block is not byte addressable.

The FADDR registers are the Flash address registers.

**Table 374. Flash Address High Register (FADDRHI - Normal Mode)**

0x0108

	7	6	5	4	3	2	1	0
R	0	0	0	0	0	0	0	0
W								
Reset	0	0	0	0	0	0	0	0

**Table 375. Flash Address Low Register (FADDRLO - Normal Mode)**

0x0109

	7	6	5	4	3	2	1	0
R	0	0	0	0	0	0	0	0
W								
Reset	0	0	0	0	0	0	0	0

**Table 376. Flash Address High Register (FADDRHI - Special Mode)**

0x0108

	7	6	5	4	3	2	1	0	
R	0	0	FAB[13:8]						
W									
Reset	0	0	0	0	0	0	0	0	

**Table 377. Flash Address Low Register (FADDRLO - Special Mode)**

0x0109								
	7	6	5	4	3	2	1	0
R	FAB[7:0]							
W	FAB[7:0]							
Reset	0	0	0	0	0	0	0	0

All FADDR bits read 0 and are not writable in normal mode.  
All assigned FADDR bits are readable and writable in special mode.

#### 4.36.3.4.4 Flash Data Registers (FDATA)

The FDATA registers are the Flash data registers.

**Table 378. Flash Data High Register (FDATAHI - Normal Mode)**

0x010A								
	7	6	5	4	3	2	1	0
R	0	0	0	0	0	0	0	0
W								
Reset	0	0	0	0	0	0	0	0

**Table 379. Flash Data Low Register (FDATALO - Normal Mode)**

0x010B								
	7	6	5	4	3	2	1	0
R	0	0	0	0	0	0	0	0
W								
Reset	0	0	0	0	0	0	0	0

**Table 380. Flash Data High Register (FDATAHI - Special Mode)**

0x010A								
	7	6	5	4	3	2	1	0
R	FD[15:8]							
W	FD[15:8]							
Reset	0	0	0	0	0	0	0	0

**Table 381. Flash Data Low Register (FDATALO - Special Mode)**

0x010B

	7	6	5	4	3	2	1	0
R	FD[7:0]							
W	FD[7:0]							
Reset	0	0	0	0	0	0	0	0

All FDATA bits read 0 and are not writable in normal mode.  
 All FDATA bits are readable and writable in special mode. The FDATA bits are indirectly written to when writing to an address within the Flash block, as part of a command write sequence.

**4.36.3.4.5 Flash Reserved2 Register (FRSV2)**

The FRSV32 register is reserved for factory testing.

**Table 382. Flash Reserved2 Register (FRSV2)**

0x010C

	7	6	5	4	3	2	1	0
R	0	0	0	0	0	0	0	0
W								
Reset	0	0	0	0	0	0	0	0

All FRSV32 bits read 0 and are not writable.

**4.36.3.4.6 Flash Reserved3 Register (FRSV3)**

The FRSV3 register is reserved for factory testing.

**Table 383. Flash Reserved3 Register (FRSV3)**

0x010D

	7	6	5	4	3	2	1	0
R	0	0	0	0	0	0	0	0
W								
Reset	0	0	0	0	0	0	0	0

All FRSV3 bits read 0 and are not writable.

#### 4.36.3.4.7 Flash Reserved4 Register (FRSV4)

The FRSV4 register is reserved for factory testing.

**Table 384. Flash Reserved4 Register (FRSV4)**

0x010E

	7	6	5	4	3	2	1	0
R	0	0	0	0	0	0	0	0
W								
Reset	0	0	0	0	0	0	0	0

All FRSV4 bits read 0 and are not writable.

#### 4.36.3.4.8 Flash Reserved5 Register (FRSV5)

The FRSV5 register is reserved for factory testing.

**Table 385. Flash Reserved5 Register (FRSV5)**

0x010F

	7	6	5	4	3	2	1	0
R	0	0	0	0	0	0	0	0
W								
Reset	0	0	0	0	0	0	0	0

All FRSV5 bits read 0 and are not writable.

#### 4.36.3.4.9 Flash Option Register (FOPT)

The FOPT register is the Flash option register.

**Table 386. Flash Option Register (FOPT)**

	7	6	5	4	3	2	1	0
R	NV[7:0]							
W								
Reset	F	F	F	F	F	F	F	F

 = Unimplemented or Reserved

All bits in the FOPT register are readable but are not writable.

During the reset sequence, the FOPT register is loaded from the Flash nonvolatile byte in the Flash configuration field at global address 0x7F0E located in P-Flash memory (see [Table 351](#)) as indicated by reset condition F in [Table 386](#). If a double bit fault is detected while reading the P-Flash phrase containing the Flash nonvolatile byte during the reset sequence, all bits in the FOPT register are set.

**Table 387. FOPT Field Descriptions**

Field	Description
7–0 NV[7:0]	<b>Nonvolatile Bits</b> — The NV[7:0] bits are available as nonvolatile bits. Refer to the device user guide for proper use of the NV bits.

## 4.36.4 Functional Description

### 4.36.4.1 Flash Command Operations

Flash command operations are used to execute program, erase, and erase verify algorithms described in this section. The program and erase algorithms are controlled by the Flash memory controller whose time base, FCLK, is derived from the bus clock via a programmable divider.

The next sections describe:

1. How to write the FCLKDIV register to set FCLK
2. Command write sequences to program, erase, and erase verify operations on the Flash memory
3. Valid Flash commands
4. Effects resulting from illegal Flash command write sequences or aborting Flash operations

#### 4.36.4.1.1 Writing the FCLKDIV Register

##### NOTE

The values loaded into the FCLKDIV register are different from those loaded into the FCLKDIV register on prior S12 Flash modules, as they were based on the oscillator frequency.

Prior to issuing any Flash command after a reset, the user is required to write the FCLKDIV register to divide the bus clock down to within the 150 to 200 kHz range.

If it is defined:

- FCLK as the clock of the Flash timing control block
- INT(x) as taking the integer part of x (e.g. INT(4.323) = 4)

then FCLKDIV bits PRDIV8 and FDIV[5:0] are to be set as described in [Figure 83](#).

For example, if the bus clock frequency is 20 MHz, FCLKDIV bits FDIV[5:0] should be set to 0x0C (001100), and bit PRDIV8 set to 1. The resulting FCLK frequency is then 192 kHz. In this case, the Flash program and erase algorithm timings are increased over the optimum target by:

$$(200 - 192)/200 = 4\%$$

**Eqn. 1**

##### CAUTION

Program and erase command execution time increases proportionally with the period of FCLK. Programming or erasing the Flash memory with FCLK < 150 kHz should be avoided. Setting FCLKDIV to a value such that FCLK < 150 kHz can destroy the Flash memory due to overstress. Setting FCLKDIV to a value such that FCLK > 200 kHz can result in incomplete programming or erasure of the Flash memory cells.

If the FCLKDIV register is written, the FDIVLD bit is set automatically. If the FDIVLD bit is 0, the FCLKDIV register has not been written since the last reset. If the FCLKDIV register has not been written to, the Flash command loaded during a command write sequence does not execute and the ACCERR flag in the FSTAT register sets.

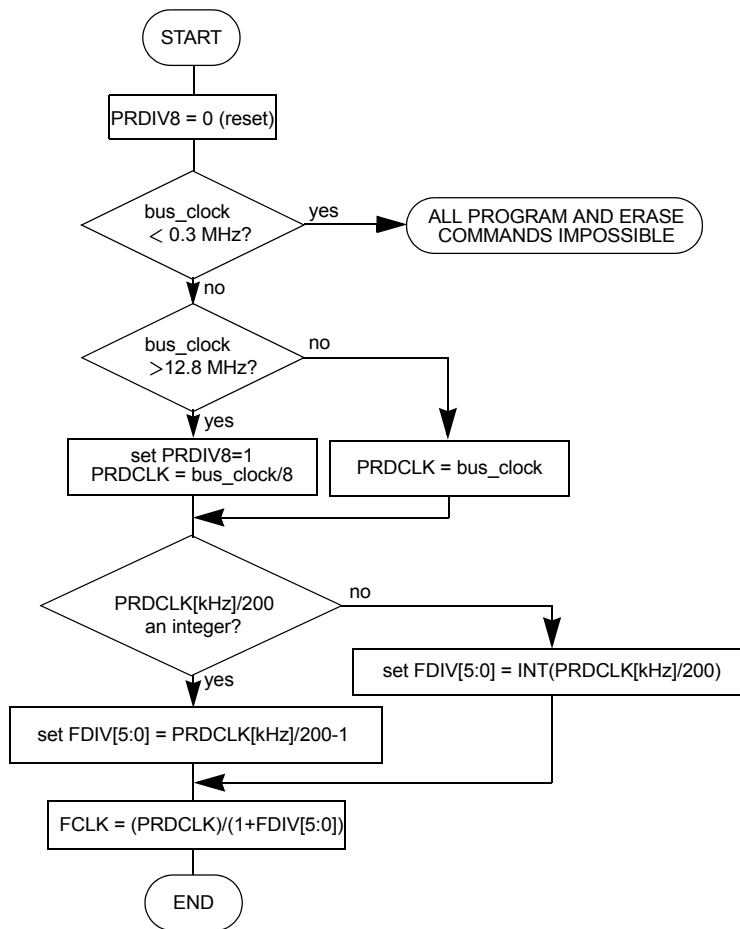

Figure 83. Determination Procedure for PRDIV8 and FDIV Bits

#### 4.36.4.1.2 Command Write Sequence

The Flash command controller is used to supervise the command write sequence to execute program, erase, and erase verify algorithms. Before starting a command write sequence, the ACCERR and PVIOL flags in the FSTAT register must be clear and the CBEIF flag must be set (see Section 4.36.3.4).

A command write sequence consists of three steps which must be strictly adhered to with writes to the Flash module not permitted between the steps. However, Flash register and array reads are allowed during a command write sequence. The basic command write sequence is as follows:

1. Write to a valid address in the Flash array memory.
2. Write a valid command to the FCMD register.
3. Clear the CBEIF flag in the FSTAT register by writing a 1 to CBEIF to launch the command.

Once a command is launched, the completion of the command operation is indicated by the setting of the CCIF flag in the FSTAT register with an interrupt generated, if enabled. The CCIF flag sets upon completion of all active and buffered burst program commands.

#### 4.36.4.2 Flash Commands

##### CAUTION

A Flash block address must be in the erased state before being programmed. Cumulative programming of bits within a Flash block address is not allowed except for the status field updates required in EEPROM emulation applications.

Table 388 summarizes the valid Flash commands along with the effects of the commands on the Flash block.

**Table 388. Flash Command Description**

FCMDB	NVM Command	Function on Flash Memory
0x05	Erase Verify	Verify all memory bytes in the Flash array memory are erased. If the Flash array memory is erased, the BLANK flag in the FSTAT register sets upon command completion.
0x20	Program	Program an address in the Flash array.
0x25	Burst Program	Program an address in the Flash array with the internal address incrementing after the program operation.
0x40	Sector Erase	Erase all memory bytes in a sector of the Flash array.
0x41	Mass Erase	Erase all memory bytes in the Flash array. A mass erase of the full Flash array is only possible when no protection is enabled prior to launching the command.
0x75	Set Verify Margin Level	Set sense-amp margin levels for verifying Flash array contents (special mode only).

#### 4.36.4.2.1 Erase Verify Command

The erase verify operation verifies the entire Flash array memory is erased. An example flow to execute the erase verify operation is shown in [Figure 84](#). The erase verify command write sequence is as follows:

1. Write to an aligned Flash block address to start the command write sequence for the erase verify command. The address and data written is ignored.
2. Write the erase verify command, 0x05, to the FCMD register.
3. Clear the CBEIF flag in the FSTAT register by writing a 1 to CBEIF to launch the erase verify command.

After launching the erase verify command, the CCIF flag in the FSTAT register sets after the operation has completed. The number of bus cycles required to execute the erase verify operation is equal to the number of addresses in the Flash array memory plus several bus cycles, as measured from the time the CBEIF flag is cleared, until the CCIF flag is set. Upon completion of the erase verify operation, the BLANK flag in the FSTAT register is set if all addresses in the Flash array memory are verified to be erased. If any address in the Flash array memory is not erased, the erase verify operation terminates, the BLANK flag in the FSTAT register remains clear, and the FAIL flag in the FSTAT register sets in special mode.

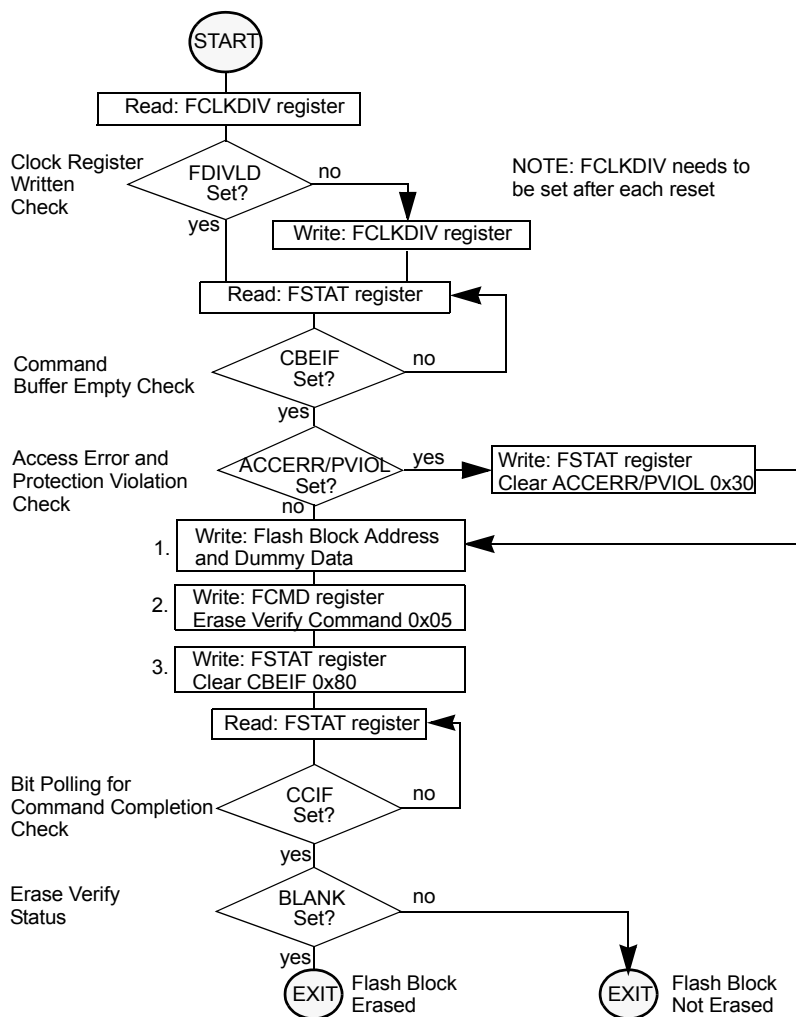

Figure 84. Example Erase Verify Command Flow

#### 4.36.4.2.2 Program Command

The program operation programs a previously erased address in the Flash memory using an embedded algorithm. An example flow to execute the program operation is shown in Figure 85. The program command write sequence is as follows:

1. Write to an aligned Flash block address to start the command write sequence for the program command. The data written is programmed to the address written.
2. Write the program command, 0x20, to the FCMD register.
3. Clear the CBEIF flag in the FSTAT register by writing a 1 to CBEIF to launch the program command.

If an address to be programmed is in a protected area of the Flash block, the PVIOL flag in the FSTAT register sets and the program command does not launch. Once the program command has successfully launched, the CCIF flag in the FSTAT register sets after the program operation has completed.

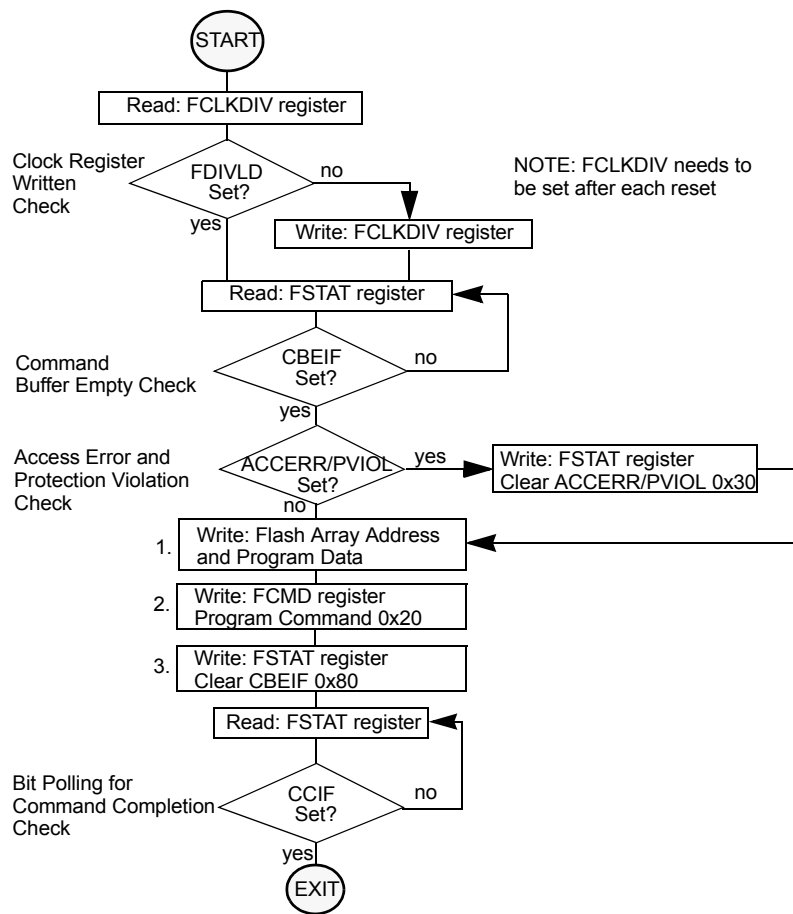

Figure 85. Example Program Command Flow

### 4.36.4.2.3 Burst Program Command

The burst program operation programs previously erased data in the Flash memory using an embedded algorithm. While burst programming, two internal data registers operate as a buffer and a register (2-stage FIFO), so a second burst programming command along with the necessary data can be stored to the buffers, while the first burst programming command is still in progress. This pipelined operation allows a time optimization when programming more than one consecutive address on a specific row in the Flash array as the high voltage generation can be kept active in between two programming commands.

An example flow to execute the burst program operation is shown in Figure 86. The burst program command write sequence is as follows:

1. Write to an aligned Flash block address to start the command write sequence for the burst program command. The data written is programmed to the address written.
2. Write the program burst command, 0x25, to the FCMD register.
3. Clear the CBEIF flag in the FSTAT register by writing a 1 to CBEIF to launch the program burst command.
4. After the CBEIF flag in the FSTAT register returns to a 1 (interrupt generated, if enabled), repeat steps 1 through 3. The address written is ignored but is incremented internally.

The burst program procedure can be used to program the entire Flash memory, even while crossing row boundaries within the Flash array. If data to be burst programmed falls within a protected area of the Flash array, the PVIOL flag in the FSTAT register sets and the burst program command does not launch. Once the burst program command has successfully launched, the CCIF flag in the FSTAT register sets after the burst program operation has completed, unless a new burst program command write sequence has been buffered. By executing a new burst program command write sequence on sequential addresses after the CBEIF flag in the FSTAT register has been set, greater than 50% faster programming time for the entire Flash array can be effectively achieved, when compared to using the basic program command.

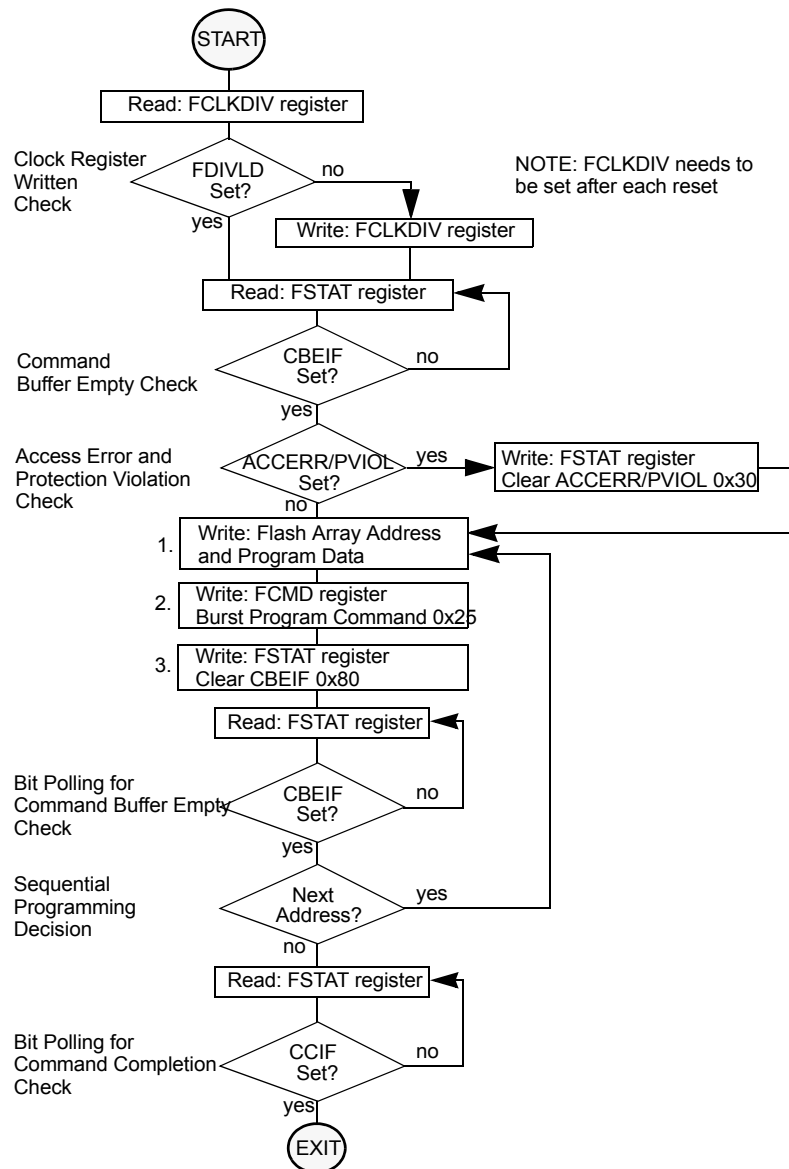

Figure 86. Example Burst Program Command Flow

#### 4.36.4.2.4 Sector Erase Command

##### NOTE

In case the PVIOL or ACCERR flags are asserted by some event occurring in between the erase pulses, the customer application must clear the flags in FSTAT register before resuming the sequence of 16 pulses.

The sector erase operation erases all addresses in a 512 byte sector of Flash memory using an embedded algorithm. The overall erase time has been divided into 16 erase pulses to allow faster system response. The customer application has to guarantee all 16 pulses are performed before writing into the Flash sector being erased. There is no requirement to have those pulses as consecutive operations.

An example flow to execute the sector erase operation is shown in [Figure 87](#). The sector erase command write sequence is as follows:

1. Write to an aligned Flash block address to start the command write sequence for the sector erase command. The Flash address written determines the sector to be erased while the data written is ignored.
2. Write the sector erase command, 0x40, to the FCMD register.
3. Clear the CBEIF flag in the FSTAT register by writing a 1 to CBEIF to launch the sector erase command.

4. Wait for the CCIF flag in the FSTAT register to set signifying completion of the sector erase operation.
5. Repeat steps 1 through 4 until all 16 sector erase pulses have been executed. Address must be in the same Flash sector.

If a Flash sector to be erased is in a protected area of the Flash block, the PVIOL flag in the FSTAT register sets and the sector erase command does not launch. Once the sector erase command has successfully launched, the CCIF flag in the FSTAT register sets after the sector erase operation has completed.

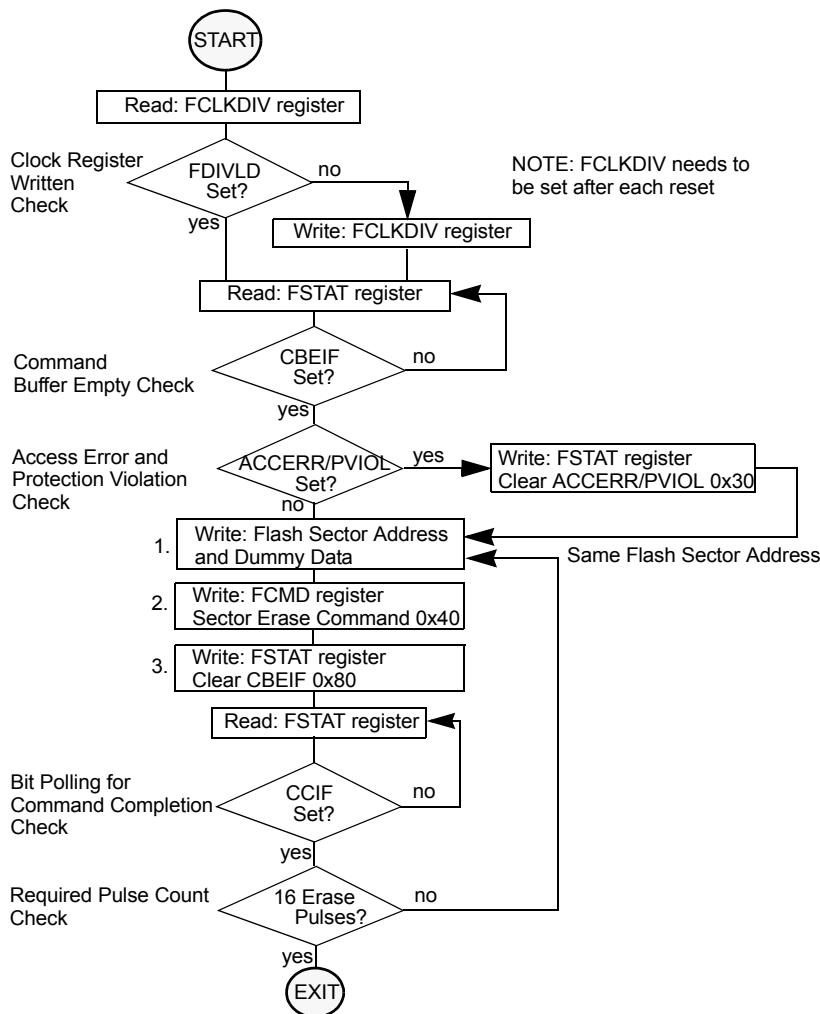

Figure 87. Example Sector Erase Command Flow

#### 4.36.4.2.5 Mass Erase Command

The mass erase operation erases the entire Flash array memory using an embedded algorithm. An example flow to execute the mass erase operation is shown in Figure 88. The mass erase command write sequence is as follows:

1. Write to an aligned Flash block address to start the command write sequence for the mass erase command. The address and data written are ignored.
2. Write the mass erase command, 0x41, to the FCMD register.
3. Clear the CBEIF flag in the FSTAT register by writing a 1 to CBEIF to launch the mass erase command.

If the Flash array memory to be mass erased contains any protected area, the PVIOL flag in the FSTAT register sets and the mass erase command does not launch. Once the mass erase command has successfully launched, the CCIF flag in the FSTAT register sets after the mass erase operation has completed.

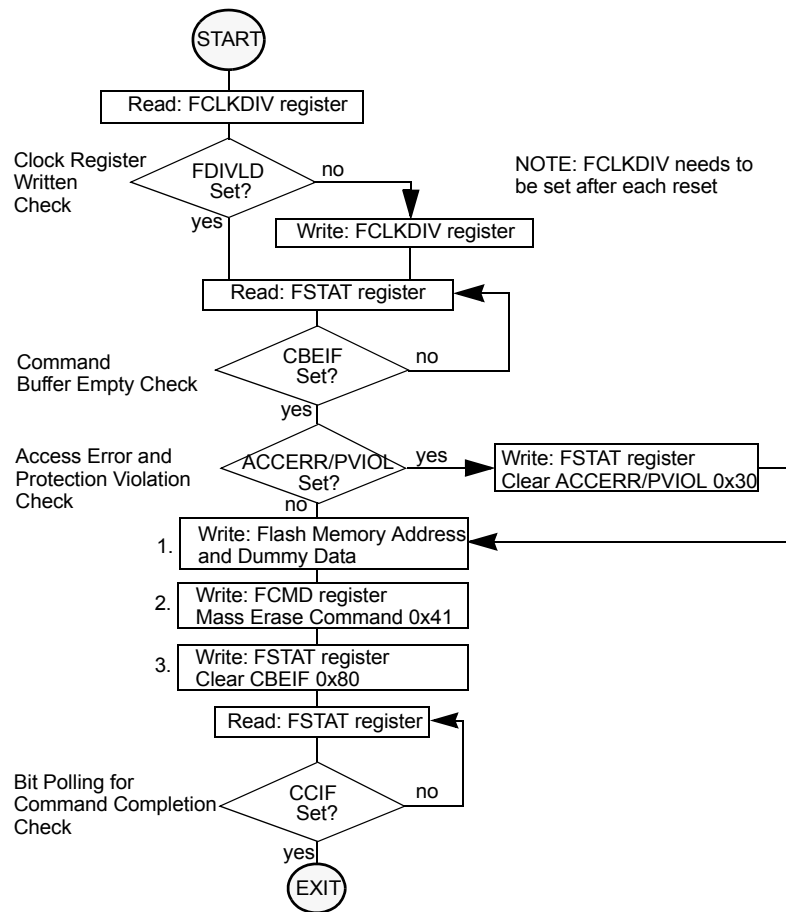

Figure 88. Example Mass Erase Command Flow

#### 4.36.4.2.6 Set Verify Margin Level Command

The set verify margin level operation, available only in special mode, sets the margin level in the Flash array sense-amps to allow content validation with margin to the normal level for subsequent Flash array reads. The set verify margin level command should only be used to validate initial programming of the Flash array.

An example flow to execute the set verify margin level operation is shown in Figure 89. The set verify margin level command write sequence is as follows:

1. Write to an aligned Flash block address to start the command write sequence for the set verify margin level command. The address is ignored while the data written sets the margin level as shown in Table 389.
2. Write the set verify margin level command, 0x75, to the FCMD register.
3. Clear the CBEIF flag in the FSTAT register by writing a 1 to CBEIF to launch the set verify margin level command.

Once the set verify margin level command has successfully launched, the CCIF flag in the FSTAT register sets after the set verify margin level operation has completed.

Table 389. Flash Array Margin Level Settings

Command Data Field	Margin Level Setting	Description
0x0000	Normal	Sets normal level for Flash array reads
0x0005	Margin 0	Sets test level to validate margin to reading 0's
0x0024	Margin 1	Sets test level to validate margin to reading 1's

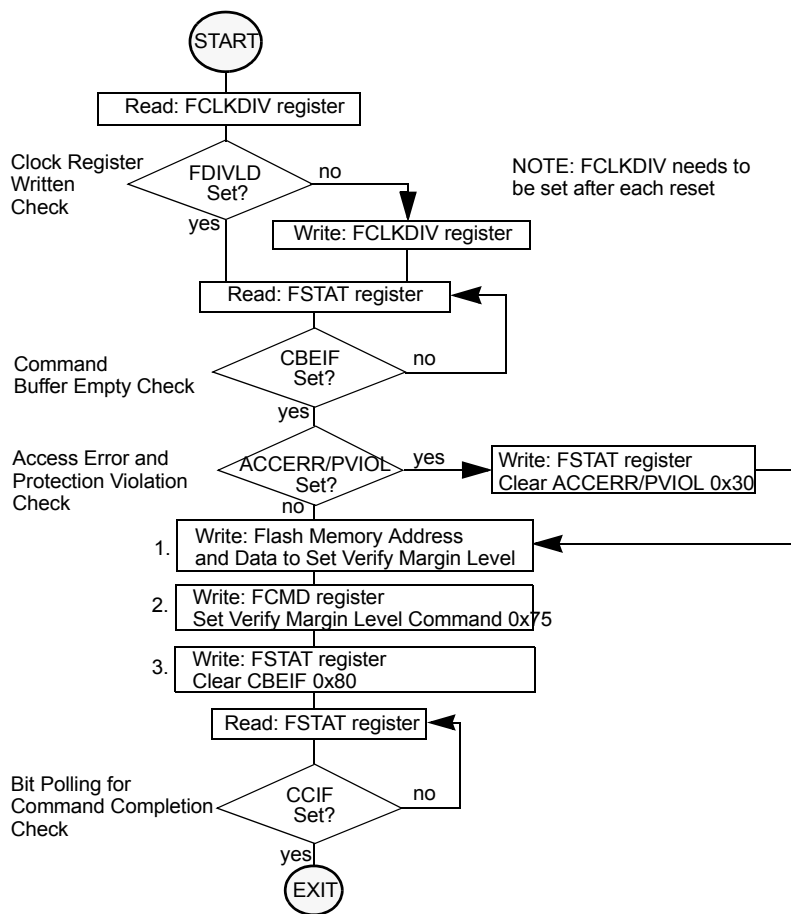

Figure 89. Example Set Verify Margin Level Command Flow (Special Mode only)

### 4.36.4.3 Illegal Flash Operations

#### 4.36.4.3.1 Flash Access Violations

The ACCERR flag is set during the command write sequence if any of the following illegal steps are performed, causing the command write sequence to immediately abort:

1. Writing to a Flash address before initializing the FCLKDIV register.
2. Writing a byte or misaligned word to a valid Flash address. Writing to any Flash register other than FCMD after writing to a Flash address.
3. Writing to a second Flash address in the same command write sequence.
4. Writing an invalid command to the FCMD register, unless the address written was in a protected area of the Flash array.
5. Writing a command other than burst program, while CBEIF is set and CCIF is clear.
6. When security is enabled, writing a command other than erase verify or mass erase to the FCMD register, when the write originates from a non-secure memory location or from the background debug mode.
7. Writing to a Flash address after writing to the FCMD register.
8. Writing to any Flash register other than FSTAT (to clear CBEIF) after writing to the FCMD register.
9. Writing a 0 to the CBEIF flag in the FSTAT register to abort a command write sequence.

The ACCERR flag also sets if the MCU enters stop mode while any command is active (CCIF=0). The operation is aborted immediately and, if burst programming, any pending burst program command is purged (see Section 4.36.5.2, "Stop Mode").

The ACCERR flag does not set if any Flash register is read during a valid command write sequence. If the Flash memory is read during execution of an algorithm (CCIF = 0), the read operation returns invalid data and the ACCERR flag does not set.

If the ACCERR flag is set in the FSTAT register, the user must clear the ACCERR flag before starting another command write sequence (see [Section 4.36.3.4, "Flash Status Register \(FSTAT\)"](#)).

#### 4.36.4.3.2 Flash Protection Violations

The PVIOL flag is set after the command is written to the FCMD register during a command write sequence, if any of the following illegal operations are attempted, causing the command write sequence to immediately abort:

1. Writing the program command if the address written in the command write sequence was in a protected area of the Flash array.
2. Writing the sector erase command if the address written in the command write sequence was in a protected area of the Flash array.
3. Writing the mass erase command while any Flash protection is enabled.
4. Writing an invalid command if the address written in the command write sequence was in a protected area of the Flash array.

If the PVIOL flag is set in the FSTAT register, the user must clear the PVIOL flag before starting another command write sequence (see [Section 4.36.3.4, "Flash Status Register \(FSTAT\)"](#)).

### 4.36.5 Operating Modes

#### 4.36.5.1 Wait Mode

If a command is active (CCIF = 0) when the MCU enters Wait mode, the active command and any buffered command complete their action.

The Flash module can recover the MCU from wait mode if the CBEIF and CCIF interrupts are enabled (see [Section 4.36.8, "Interrupts"](#)).

#### 4.36.5.2 Stop Mode

##### NOTE

As active commands are immediately aborted when the MCU enters stop mode, it is strongly recommended the user does not use the STOP instruction during program or erase operations.

If a command is active (CCIF = 0) when the MCU enters stop mode, the operation aborts, and if the operation is program or erase, the Flash array data being programmed or erased may be corrupted and the CCIF and ACCERR flags are set. If active, the high voltage circuitry to the Flash array immediately switches off when entering Stop mode. Upon exit from Stop mode, the CBEIF flag is set and any buffered command does not launch. The ACCERR flag must be cleared before starting a command write sequence (see [Section 4.36.4.1.2, "Command Write Sequence"](#)).

#### 4.36.5.3 Background Debug Mode

In background debug mode (BDM), the FPROT register is writable. If the MCU is unsecured, then all Flash commands listed in [Table 388](#) can be executed. If the MCU is secured and is in special mode, only the erase verify and mass erase commands can be executed.

### 4.36.6 Flash Module Security

The Flash module provides the necessary security information to the MCU. During each reset sequence, the Flash module determines the security state of the MCU as defined in [Section 4.36.3.3.2, "Flash Security Register \(FSEC\)"](#).

The contents of the Flash security byte in the Flash configuration field (see [Section 4.36.3.1.1](#)) must be changed directly by programming the Flash security byte location, when the MCU is unsecured and the sector containing the Flash security byte is unprotected. If the Flash security byte is left in a secured state, any reset causes the MCU to initialize into a secure operating mode.

#### 4.36.6.1 Unsecuring the MCU Using Backdoor Key Access

The MCU may be unsecured by using the backdoor key access feature, which requires knowledge of the contents of the backdoor keys (see [Section 4.36.3.1.1](#)). If the KEYEN[1:0] bits are in the enabled state (see [Section 4.36.3.3.2](#)) and the KEYACC bit is set, a write to a backdoor key address in the Flash memory triggers a comparison between the written data and the backdoor key data stored in the Flash memory. If all backdoor keys are written to the correct addresses in the correct order, and the data matches the backdoor keys stored in the Flash memory, the MCU is unsecured. The data must be written to the backdoor keys sequentially. Values 0x0000 and 0xFFFF are not permitted as backdoor keys. While the KEYACC bit is set, reads of the Flash memory returns valid data.

The user code stored in the Flash memory must have a method of receiving the backdoor keys from an external stimulus. This external stimulus would typically be through one of the on-chip serial ports.

If the KEYEN[1:0] bits are in the enabled state (see [Section 4.36.3.3.2](#)), the MCU can be unsecured by the backdoor key access sequence described below:

1. Set the KEYACC bit in the Flash configuration register (FCNFG).
2. Sequentially write the correct four words to the Flash addresses containing the backdoor keys.
3. Clear the KEYACC bit. Depending on the user code used to write the backdoor keys, a wait cycle (NOP) may be required before clearing the KEYACC bit.
4. If all data written match the backdoor keys, the MCU is unsecured and the SEC[1:0] bits in the FSEC register are forced to an unsecured state.

The backdoor key access sequence is monitored by an internal security state machine. An illegal operation during the backdoor key access sequence causes the security state machine to lock, leaving the MCU in the secured state. A reset of the MCU causes the security state machine to exit the lock state and allow a new backdoor key access sequence to be attempted. The following operations during the backdoor key access sequence locks the security state machine:

1. If any of the keys written does not match the backdoor keys programmed in the Flash array.
2. If the keys are written in the wrong sequence.
3. If any of the keys written are all 0's or all 1's.
4. If the KEYACC bit does not remain set while the keys are written.
5. If any of the keys are written on successive MCU clock cycles.
6. Executing a STOP instruction before all keys have been written.

After the backdoor keys have been correctly matched, the MCU is unsecured. Once the MCU is unsecured, the Flash security byte can be programmed to the unsecure state, if desired.

In the unsecure state, the user has full control of the contents of the backdoor keys by programming the associated addresses in the Flash configuration field (see [Section 4.36.3.1.1](#)).

The security as defined in the Flash security byte is not changed by using the backdoor key access sequence to unsecure. The stored backdoor keys are unaffected by the backdoor key access sequence. After the next reset of the MCU, the security state of the Flash module is determined by the Flash security byte. The backdoor key access sequence has no effect on the program and erase protections defined in the Flash protection register (FPROT).

It is not possible to unsecure the MCU in special mode by using the backdoor key access sequence in background debug mode (BDM).

#### 4.36.6.2 Unsecuring the MCU in Special Mode Using BDM

The MCU can be unsecured in special mode by erasing the Flash module by the following method:

1. Reset the MCU into special mode, delay while the erase test is performed by the BDM secure ROM.
2. Send BDM commands to disable protection in the Flash module.
3. Execute a mass erase command write sequence to erase the Flash memory.

After the CCIF flag sets to indicate the mass operation has completed, reset the MCU into special mode. The BDM secure ROM verifies the Flash memory is erased and asserts the UNSEC bit in the BDM status register. This BDM action causes the MCU to override the Flash security state and the MCU is unsecured. All BDM commands are enabled and the Flash security byte may be programmed to the unsecure state by the following method:

1. Send BDM commands to execute a program sequence to program the Flash security byte to the unsecured state.
2. Reset the MCU.

## 4.36.7 Resets

### 4.36.7.1 Flash Reset Sequence

On each reset, the Flash module executes a reset sequence to hold CPU activity, while reading the following resources from the Flash block:

- MCU control parameters (see [Section 4.36.3.2](#))
- Flash protection byte (see [Section 4.36.3.1.1](#) and [Section 4.36.3.3.5](#))
- Flash nonvolatile byte (see [Section 4.36.3.1.1](#))
- Flash security byte (see [Section 4.36.3.1.1](#) and [Section 4.36.3.3.2](#))

### 4.36.7.2 Reset While Flash Command Active

If a reset occurs while any Flash command is in progress, the command is immediately aborted. The state of the Flash array address being programmed or the sector/block being erased is not guaranteed.

## 4.36.8 Interrupts

### NOTE

Vector addresses and their relative interrupt priority are determined at the MCU level.

The Flash module can generate an interrupt when all Flash command operations have completed, when the Flash address, data and command buffers are empty.

**Table 390. Flash Interrupt Sources**

Interrupt Source	Interrupt Flag	Local Enable	Global (CCR) Mask
Flash Address, Data and Command Buffers empty	CBEIF (FSTAT register)	CBEIE (FCNFG register)	I Bit
All Flash commands completed	CCIF (FSTAT register)	CCIE (FCNFG register)	I Bit

### 4.36.8.1 Description of Flash Interrupt Operation

The logic used for generating interrupts is shown in [Figure 90](#). The Flash module uses the CBEIF and CCIF flags in combination with the CBEIE and CCIE enable bits to generate the Flash command interrupt request.

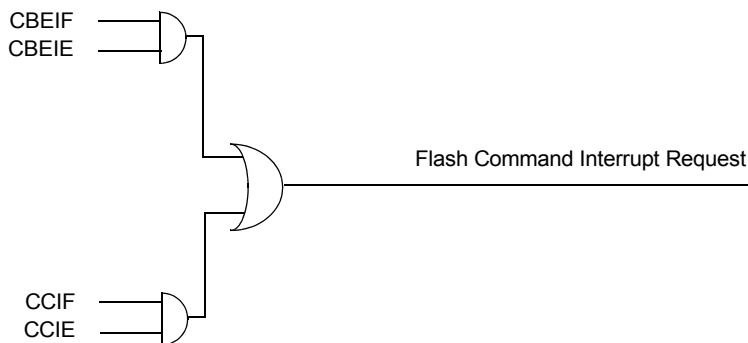

**Figure 90. Flash Command Interrupt Implementation**

For a detailed description of the register bits, refer to [Section 4.36.3.3.4, "Flash Configuration Register \(FCNFG\)"](#) and [Section 4.36.3.4, "Flash Status Register \(FSTAT\)"](#).

## 4.37 Die-to-Die Initiator (D2DIV1)

### 4.37.1 Introduction

This section describes the functionality of the die-to-die (D2DIV1) initiator block especially designed for low cost connections between a microcontroller die (Interface Initiator) and an analog die (Interface Target) located in the same package.

The D2DI block

- realizes the initiator part of the D2D interface, including supervision and error interrupt generation
- generates the clock for this interface
- disables/enables the interrupt from the D2D interface

#### 4.37.1.1 Overview

The D2DI is the initiator for a data transfer to and from a target typically located on another die in the same package. It provides a set of configuration registers and two memory mapped 256 Byte address windows. When writing to a window, a transaction is initiated sending a write command, followed by an 8-bit address and the data byte or word to the target. When reading from a window, a transaction is initiated sending a read command, followed by an 8-bit address to the target. The target then responds with the data. The basic idea is so a peripheral located on another die, can be addressed like an on-chip peripheral, except for a small transaction delay.

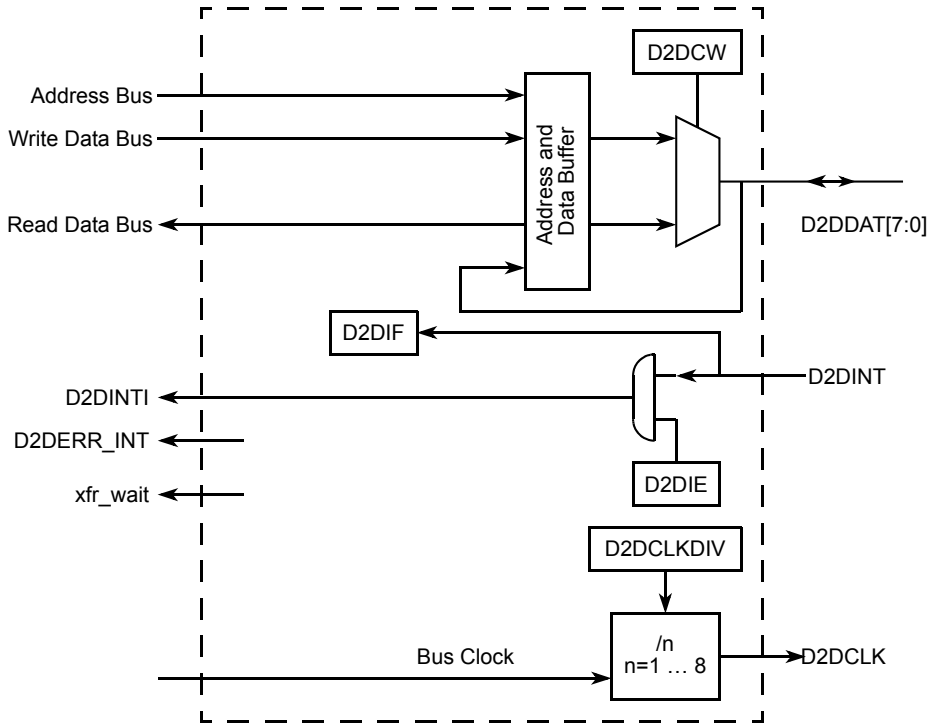

Figure 91. Die-to-Die Initiator (D2DI) Block Diagram

#### 4.37.1.2 Features

The main features of this block are

- Software transparent, memory mapped access to peripherals on target die
  - 256 Byte address window
  - Supports blocking read or write as well as non-blocking write transactions
- Scalable interface clock divide by 1, 2, 3 of bus clock
- Clock halt on system STOP
- Configurable for 4- or 8-bit wide transfers

- Configurable timeout period
- Non-maskable interrupt on transaction errors
- Transaction Status and Error Flags
- Interrupt enable for receiving interrupt (from D2D target)

### 4.37.1.3 Modes of Operation

#### 4.37.1.3.1 D2DI in STOP/WAIT Mode

The D2DI stops working in STOP/WAIT mode. The D2DCLK signal as well as the data signals used are driven low (only after the end of the current high phase, as defined by D2DCLKDIV). Waking from STOP/WAIT mode, the D2DCLK line starts clocking again and the data lines are driven low until the first transaction starts.

STOP and WAIT mode are entered by different CPU instructions. In the WAIT mode, the behavior of the D2DI can be configured (D2DSWAI). Every (enabled) interrupt can be used to leave the STOP and WAIT mode.

#### 4.37.1.3.2 D2DI in special modes

The MCU can enter a special mode (used for test and debugging purposes as well as programming the FLASH). In the D2DI the “write-once” feature is disabled. See the MCU description for details.

### 4.37.2 External Signal Description

The D2DI optionally uses 6 or 10 port pins. The functions of those pins depends on the settings in the D2DCTL0 register, when the D2DI module is enabled.

#### 4.37.2.1 D2DCLK

##### NOTE

The maximum allowed D2D target frequency ( $f_{D2D}$ ) might be lower than the maximum initiator frequency.

When the D2DI is enabled this pin is the clock output. This signal is low if the initiator is disabled, in STOP mode or in WAIT mode (with D2DSWAI asserted), otherwise it is a continuous clock. This pin may be shared with general purpose functionality if the D2DI is disabled.

#### 4.37.2.2 D2DDAT[7:4]

When the D2DI is enabled and the interface connection width D2DCW is set to be 8-bit wide, those lines carry the data bits 7:4 acting as outputs or inputs. When they act as inputs pull-down elements are enabled. If the D2DI is disabled or if the interface connection width is set as 4-bit wide, the pins may be shared with general purpose pin functionality. In the MM912F634 configuration, D2DDAT [7:4] are not bonded, and act as GPIO inputs. These pads are in high-impedance mode. To avoid any leakage in Stop mode, D2DDAT [7:0] should be configured as an output by writing 0xF0 on DDRD register (0x007).

#### 4.37.2.3 D2DDAT[3:0]

When the D2DI is enabled those lines carry the data bits 3:0 acting as outputs or inputs. When they act as inputs pull-down elements are enabled. If the D2DI is disabled the pins and may be shared with general purpose pin functionality.

#### 4.37.2.4 D2DINT

The D2DINT is an active input interrupt input driven by the target device. The pin has an active pull-down device. If the D2DI is disabled, the pin may be shared with general purpose pin functionality.

**Table 391. Signal Properties**

Name	Primary (D2DEN=1)	I/O	Secondary (D2DEN=0)	Reset	Comment	Pull-down
D2DDAT[7:0]	Bi-directional Data Lines	I/O	GPIO	0	driven low if in STOP mode	Active <sup>(197)</sup>
D2DCLK	Interface Clock Signal	O	GPIO	0	low if in STOP mode	—
$\overline{\text{D2DINT}}$	Active High Interrupt	I	GPIO	—	—	Active <sup>(198)</sup>

Note:

197. Active if in input state, only if D2DEN=1

198. only if D2DEN=1

See the port interface module (PIM) guide for details of the GPIO function.

### 4.37.3 Memory Map and Register Definition

#### 4.37.3.1 Memory Map

The D2DI memory map is split into three sections.

1. An eight byte set of control registers.
2. A 256 byte window for blocking transactions.
3. A 256 byte window for non-blocking transactions.

See the chapter “Device Memory Map” for the register layout (distribution of these sections).

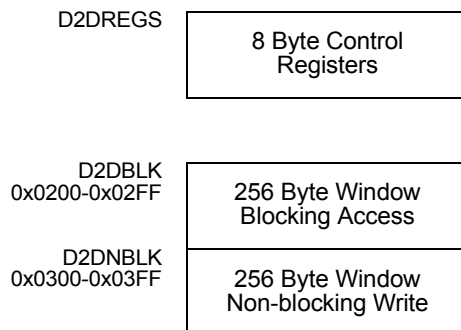

**Figure 92. D2DI Top Level Memory Map**

A summary of the registers associated with the D2DI block is shown in Figure 240. Detailed descriptions of the registers and bits are given in the following subsections.

**Table 392. D2DI Register Summary**

Address	Register Name		Bit 7	6	5	4	3	2	1	Bit 0	
0x00D8	D2DCTL0	R	D2DEN	D2DCW	D2DSWAI	0	0	0	D2DCLKDIV[1:0]		
		W									
0x00D9	D2DCTL1	R	D2DIE	0	0	0	TIMEOUT[3:0]				
		W									
0x00DA	D2DSTAT0	R	ERRIF	ACKERF	CNCLF	TIMEF	TERRF	PARF	PAR1	PAR0	
		W									
0x00DB	D2DSTAT1	R	D2DIF	D2DBSY	0	0	0	0	0	0	
		W									
0x00DC	D2DADRHI	R	RWB	SZ8	0	NBLK	0	0	0	0	
		W									
0x00DD	D2DADRLO	R	ADR[7:0]								
		W									
0x00DE	D2DDATAHI	R	DATA[15:8]								
		W									
0x00DF	D2DDATALO	R	DATA[7:0]								
		W									

### 4.37.3.2 Register Definition

#### 4.37.3.2.1 D2DI Control Register 0 (D2DCTL0)

This register is used to enable and configure the interface width, the wait behavior and the frequency of the interface clock.

**Table 393. D2DI Control Register 0 (D2DCTL0)**

0x00D8		Access: User read/write									
		7	6	5	4	3	2	1	0		
R		D2DEN	D2DCW	D2DSWAI	0	0	0	D2DCLKDIV[1:0]			
W											
Reset		0	0	0	0	0	0	0	0	0	

**Table 394. D2DCTL0 Register Field Descriptions**

Field	Description
7 D2DEN	<b>D2DI Enable</b> — Enables the D2DI module. This bit is write-once in normal mode and can always be written in special modes. 0 D2DI initiator is disabled. No lines are not used, the pins have their GPIO (secondary) function. 1 D2DI initiator is enabled. After setting D2DEN = 1 the D2DDAT[7:0] (or [3:0], see D2DCW) lines are driven low with the IDLE command; the D2DCLK is driven by the divided bus clock.
6 D2DCW	<b>D2D Connection Width</b> — Sets the number of data lines used by the interface. This bit is write-once in normal modes and can always be written in special modes. 0 Lines D2DDAT[3:0] are used for four line data transfer. D2DDAT[7:4] are unused. 1 All eight interface lines D2DDAT[7:0] are used for data transfer. <sup>(199)</sup>

**Table 394. D2DCTL0 Register Field Descriptions (continued)**

Field	Description
5 D2DSWAI	<b>D2D Stop In Wait</b> — Controls the WAIT behavior. This bit can be written at any time. 0 Interface clock continues to run if the CPU enters WAIT mode 1 Interface clock stops if the CPU enters WAIT mode.
4:2	Reserved, should be written to 0 to ensure compatibility with future versions of this interface.
1:0 D2DCLKDIV	<b>Interface Clock Divider</b> — Determines the frequency of the interface clock. These bits are write-once in normal modes and can be always written in special modes. See <a href="#">Figure 93</a> for details on the clock waveforms 00 Encoding 0. Bus clock divide by 1. 01 Encoding 1. Bus clock divide by 2. 10 Encoding 2. Bus clock divide by 3. 11 Encoding 3. Bus clock divide by 4.

Note:  
199. 8-lines configuration cannot be used in the MM912F634 configuration.

The Clock Divider provides the waveforms as shown in [Figure 93](#). The duty cycle of the clock is not always 50%, the high cycle is shorter than 50% or equal but never longer, since this is beneficial for the transaction speed.

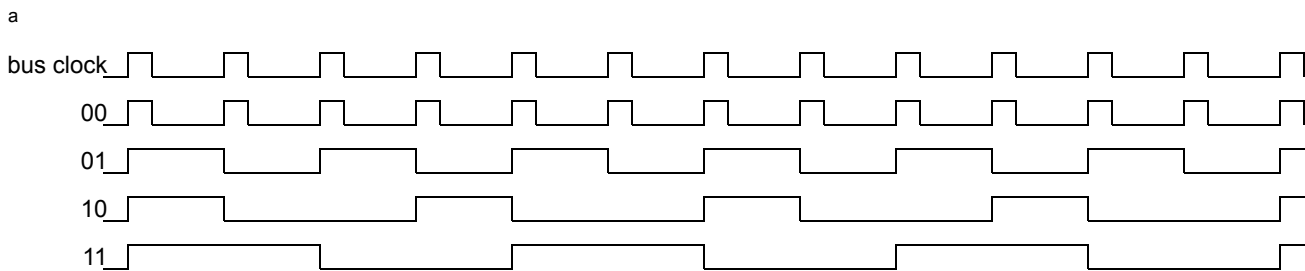

**Figure 93. Interface Clock Waveforms for Various D2DCLKDIV Encoding**

**4.37.3.2.2 D2DI Control Register 1 (D2DCTL1)**

**NOTE**

“Write once” means that after writing D2DCNTL0.D2DEN = 1 the write accesses to these bits have no effect.

This register is used to enable the D2DI interrupt and set number of D2DCLK cycles before a timeout error is asserted.

**Table 395. D2DI Control Register 1 (D2DCTL1)**

0x00D9		Access: User read/write							
		7	6	5	4	3	2	1	0
R			0	0	0	TIMOUT[3:0]			
W	D2DIE								
Reset		0	0	0	0	0	0	0	0

**Table 396. D2DCTL1 Register Field Descriptions**

Field	Description
7 D2DIE	<b>D2D Interrupt Enable</b> — Enables the external interrupt 0 External Interrupt is disabled 1 External Interrupt is enabled

**Table 396. D2DCTL1 Register Field Descriptions (continued)**

Field	Description
6:4	Reserved, should be written to 0 to ensure compatibility with future versions of this interface.
3:0 TIMOUT	<b>Time-out Setting</b> — Defines the number of D2DCLK cycles to wait after the last transaction cycle until a timeout is asserted. In case of a timeout the TIMEF flag in the D2DSTAT0 register is set. These bits are write once in normal modes and can always be written in special modes. 0000 The acknowledge is expected directly after the last transfer, i.e. the target must not insert a wait cycle. 0001 - 1111: The target may insert up to TIMOUT wait states before acknowledging a transaction until a timeout is asserted

#### 4.37.3.2.3 D2DI Status Register 0 (D2DSTAT0)

This register reflects the status of the D2DI transactions.

**Table 397. D2DI Status Register 0 (D2DSTAT0)**

0x00DA

Access: User read/write

	7	6	5	4	3	2	1	0
R	ERRIF	ACKERF	CNCLF	TIMEF	TERRF	PARF	PAR1	PAR0
W								
Reset	0	0	0	0	0	0	0	0

**Table 398. D2DI Status Register 0 Field Descriptions**

Field	Description
7 ERRIF	<b>D2DI error interrupt flag</b> — This status bit indicates the D2D initiator has detected an error condition (summary of the following five flags). This interrupt is not locally maskable. Write a 1 to clear the flag. Writing a 0 has no effect. 0 D2DI has not detected an error during a transaction. 1 D2DI has detected an error during a transaction.
6 ACKERF	<b>Acknowledge Error Flag</b> — This read-only flag indicates that in the acknowledge cycle not all data inputs are sampled high, indicating a potential broken wire. This flag is cleared when the ERRIF bit is cleared by writing a 1 to the ERRIF bit.
5 CNCLF	<b>CNCLF</b> — This read-only flag indicates the initiator has canceled a transaction and replaced it by an IDLE command due to a pending error flag (ERRIF). This flag is cleared when the ERRIF bit is cleared by writing a 1 to the ERRIF bit.
4 TIMEF	<b>Time Out Error Flag</b> — This read-only flag indicates the initiator has detected a timeout error. This flag is cleared when the ERRIF bit is cleared by writing a 1 to the ERRIF bit.
3 TERRF	<b>Transaction Error Flag</b> — This read-only flag indicates the initiator has detected the error signal during the acknowledge cycle of the transaction. This flag is cleared when the ERRIF bit is cleared by writing a 1 to the ERRIF bit.
2 PARF	<b>Parity Error Flag</b> — This read-only flag indicates the initiator has detected a parity error. Parity bits[1:0] contain further information. This flag is cleared when the ERRIF bit is cleared by writing a 1 to the ERRIF bit.
1 PAR1	<b>Parity Bit</b> — P[1] as received by the D2DI
0 PAR0	<b>Parity Bit</b> — P[0] as received by the D2DI

**4.37.3.2.4 D2DI Status Register 1 (D2DSTAT1)**

This register holds the status of the external interrupt pin and an indicator about the D2DI transaction status.

**Table 399. D2DI Status Register 1 (D2DSTAT1)**

0x00DB								Access: User read
	7	6	5	4	3	2	1	0
R	D2DIF	D2DBSY	0	0	0	0	0	0
W								
Reset	0	0	0	0	0	0	0	0

**Table 400. D2DSTAT1 Register Field Descriptions**

Field	Description
7 D2DIF	<b>D2D Interrupt Flag</b> — This read-only flag reflects the status of the D2DINT Pin. The D2D interrupt flag can only be cleared by a target specific interrupt acknowledge sequence. 0 External Interrupt is negated 1 External Interrupt is asserted
6 D2DBSY	<b>D2D Initiator Busy</b> — This read-only status bit indicates a D2D transaction is ongoing. 0 D2D initiator idle. 1 D2D initiator transaction ongoing.
5:0	Reserved, should be masked to ensure compatibility with future versions of this interface.

**4.37.3.2.5 D2DI Address Buffer Register (D2DADR)**

This read-only register contains information about the ongoing D2D interface transaction. The register content is updated when a new transaction starts. In error cases the user can track back, which transaction failed.

**Table 401. D2DI Address Buffer Register (D2DADR)**

0x00DC / 0x00DD																Access: User read
	15	14	13	12	11	10	9	8	7	6	5	4	3	2	1	0
R	RWB	SZ8	0	NBLK	0	0	0	0	ADR[7:0]							
W																
Reset	0	0	0	0	0	0	0	0	0	0	0	0	0	0	0	0

**Table 402. D2DI Address Buffer Register Bit Descriptions**

Field	Description
15 RWB	<b>Transaction Read-Write Direction</b> — This read-only bit reflects the direction of the transaction 0 Write Transaction 1 Read Transaction
14 SZ8	<b>Transaction Size</b> — This read-only bit reflects the data size of the transaction 0 16-bit transaction. 1 8-bit transaction.
13	Reserved, should be masked to ensure compatibility with future versions of this interface.
12 NBLK	<b>Transaction Mode</b> — This read-only bit reflects the mode of the transaction 0 Blocking transaction. 1 Non-blocking transaction.

**Table 402. D2DI Address Buffer Register Bit Descriptions (continued)**

Field	Description
11:8	Reserved, should be masked to ensure compatibility with future versions of this interface.
7:0 ADR[7:0]	<b>Transaction Address</b> — Those read-only bits contain the address of the transaction

#### 4.37.3.2.6 D2DI Data Buffer Register (D2DDATA)

This read-only register contains information about the ongoing D2D interface transaction. For a write transaction, the data becomes valid at the begin of the transaction. For a read transaction, the data is updated during the transaction, and is finalized when the transaction is acknowledged by the target. In error cases, the user can track back what has happened.

**Table 403. D2DI Data Buffer Register (D2DDATA)**

0x00DE / 0x00DF																Access: User read
	15	14	13	12	11	10	9	8	7	6	5	4	3	2	1	0
R	DATA15:0															
W																
Reset	0	0	0	0	0	0	0	0	0	0	0	0	0	0	0	0

**Table 404. D2DI Data Buffer Register Bit Descriptions**

Field	Description
15:0 DATA	<b>Transaction Data</b> — Those read-only bits contain the data of the transaction

Both D2DDATA and D2DADR can be read with byte accesses.

### 4.37.4 Functional Description

#### 4.37.4.1 Initialization

Out of reset the interface is disabled. The interface must be initialized by setting the interface clock speed, the timeout value, the transfer width, and finally enabling the interface. This should be done using a 16-bit write, or if using 8-bit write, D2DCTL1 must be written before D2D2CTL0.D2DEN = 1 is written. Once it is enabled in normal modes, only a reset can disable it again (write once feature).

#### 4.37.4.2 Transactions

A transaction on the D2D Interface is triggered by writing to either the 256 byte address window or reading from the address window (see STAA/LDAA 0/1 in the next figure). Depending on which address window is used, a blocking or a non-blocking transaction is performed. The address for the transaction is the 8-bit wide window relative address. The data width of the CPU read or write instructions determines if 8-bit or 16-bit wide data are transferred. There is always only one transaction active. [Figure 94](#) shows the various types of transactions explained in more detail below.

For all 16-bit read/write accesses of the CPU, the addresses are assigned according the big-endian model:

word [15:8]: addr                      word[7:0]: addr+1

addr: byte-address (8 bit wide) inside the blocking or non-blocking window, as provided by the CPU and transferred to the D2D target

word: CPU data, to be transferred from/to the D2D target

The application must care for the stretched CPU cycles (limited by the TIMEOUT value, caused by blocking or consecutive accesses), which could affect time limits, including COP (computer operates properly) supervision. The stretched CPU cycles cause the “CPU halted” phases (see [Figure 94](#)).

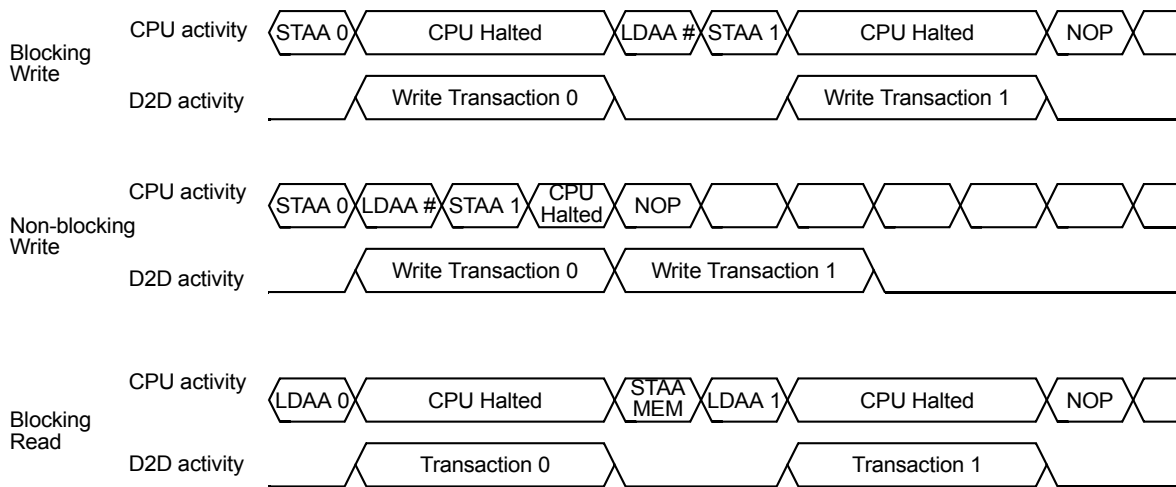

**Figure 94. Blocking and Non-blocking Transfers.**

**4.37.4.2.1 Blocking Writes**

When writing to the address window associated with blocking transactions, the CPU is held until the transaction is completed, before completing the instruction. Figure 94 shows the behavior of the CPU for a blocking write transaction shown in the following example.

```

STAA   BLK_WINDOW+OFFS0 ; WRITE0 8-bit as a blocking transaction
LDAA   #BYTE1
STAA   BLK_WINDOW+OFFS1 ; WRITE1 is executed after WRITE0 transaction is completed
NOP
    
```

Blocking writes should be used when clearing interrupt flags located in the target, or other writes which require the operation at the target is completed before proceeding with the CPU instruction stream.

**4.37.4.2.2 Non-blocking Writes**

When writing to the address window associated with non-blocking transactions, the CPU can continue before the transaction is completed. However, if there was a transaction ongoing when doing the 2nd write, the CPU is held until the first one is completed before executing the 2nd one. Figure 94 shows the behavior of the CPU for a blocking write transaction shown in the following example.

```

STAA   NONBLK_WINDOW+OFFS0; write 8-bit as a blocking transaction
LDAA   #BYTE1                ; load next byte
STAA   NONBLK_WINDOW+OFFS1; executed right after the first
NOP
    
```

As Figure 94 illustrates, non-blocking writes have a performance advantage, but care must be taken the following instructions are not affected by the change in the target caused by the previous transaction.

**4.37.4.2.3 Blocking Read**

When reading from the address window associated with blocking transactions, the CPU is held until the data is returned from the target, before completing the instruction. Figure 94 shows the behavior of the CPU for a blocking read transaction shown in the following example.

```

LDAA   BLK_WINDOW+OFFS0 ; Read 8-bit as a blocking transaction
STAA   MEM                ; Store result to local Memory
LDAA   BLK_WINDOW+OFFS1 ; Read 8-bit as a blocking transaction
    
```

**4.37.4.2.4 Non-blocking Read**

Read access to the non-blocking window is reserved for future use. When reading from the address window associated with non-blocking writes, the read returns an all 0s data byte or word. This behavior can change in future revisions.

### 4.37.4.3 Transfer Width

8-bit wide writes or reads are translated into 8-bit wide interface transactions. 16-bit wide, aligned writes or reads are translated into 16-bit wide interface transactions. 16-bit wide, misaligned writes or reads are split up into two consecutive 8-bit transactions, with the transaction on the odd address first followed by the transaction on the next higher even address. Due to the much more complex error handling (by the MCU), misaligned 16-bit transfers should be avoided.

### 4.37.4.4 Error Conditions and Handling faults

Since the S12 CPU (as well as the S08) do not provide a method to abort a transfer once started, the D2DI asserts an D2DERRINT. The ERRIF Flag is set in the D2DSTAT0 register. Depending on the error condition, further error flags are set as described below. The content of the address and data buffers are frozen, and all transactions are replaced by an IDLE command, until the error flag is cleared. If an error is detected during the read transaction of a read-modify-write instruction, or a non-blocking write transaction was followed by another write or read transaction, the second transaction is cancelled. The CNCLF is set in the D2DSTAT0 register to indicate a transaction has been cancelled. The D2DERRINT handler can read the address and data buffer register to assess the error situation. Any further transaction is replaced by IDLE until the ERRIF is cleared.

#### 4.37.4.4.1 Missing Acknowledge

If the target detects a wrong command, it does not send back an acknowledge. The same situation occurs if the acknowledge is corrupted. The D2DI detects this missing acknowledge after the timeout period configured in the TIMEOUT parameter of the D2DCTL1 register. In case of a timeout, the ERRIF and the TIMEF flags in the D2DSTAT0 register are set.

#### 4.37.4.4.2 Parity error

In the final acknowledge cycle of a transaction, the target sends two parity bits. If this parity does not match the parity calculated by the initiator, the ERRIF and the PARF flags in the D2DSTAT0 register are set. The PAR[1:0] bits contain the parity value received by the D2DI.

#### 4.37.4.4.3 Error Signal

During the acknowledge cycle the target can signal a target specific error condition. If the D2DI finds the error signal asserted during a transaction, the ERRIF and the TERRF flags in the D2DSTAT0 register are set.

### 4.37.4.5 Low Power Mode Options

#### 4.37.4.5.1 D2DI in Run Mode

In run mode with the D2D Interface enable (D2DEN) bit in the D2D control register 0 clear, the D2DI system is in a low-power, disabled state. D2D registers remain accessible, but clocks to the core of this module are disabled. On D2D lines the GPIO function is activated.

#### 4.37.4.5.2 D2DI in Wait Mode

D2DI operation in wait mode depends upon the state of the D2DSWAI bit in D2D control register 0.

- If D2DSWAI is clear, the D2DI operates normally when the CPU is in the wait mode
- If D2DSWAI is set and the CPU enters the wait mode, any pending transmission is completed. When the D2DCLK output is driven low, the clock generation is stopped, all internal clocks to the D2DI module are stopped, and the module enters a power saving state.

#### 4.37.4.5.3 D2DI in Stop Mode

If the CPU enters the STOP mode, the D2DI shows the same behavior as with the wait mode with an activated D2DSWAI bit.

### 4.37.4.6 Reset

In case of reset, any transaction is immediately stopped and the D2DI module is disabled.

### 4.37.4.7 Interrupts

The D2DI only originates interrupt requests, when D2DI is enabled (D2DIE bit in D2DCTL0 set). There are two different interrupt requests from the D2D module. The interrupt vector offset and interrupt priority are chip dependent.

#### 4.37.4.7.1 D2D External Interrupt

This is a level sensitive active high external interrupt driven by the D2DINT input. This interrupt is enabled if the D2DIE bit in the D2DCTL1 register is set. The interrupt must be cleared using a target specific clearing sequence. The status of the D2D input pin can be observed by reading the D2DIF bit in the D2DSTAT1 register.

The D2DINIT signal is asserted also in the wait and stop mode; it can be used to leave these modes.

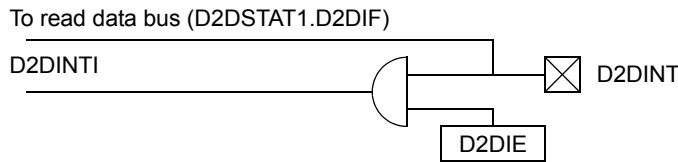

**Figure 95. D2D External Interrupt Scheme**

#### 4.37.4.7.2 D2D Error Interrupt

Those D2D interface specific interrupts are level sensitive and are all cleared by writing a 1 to the ERRIF flag in the D2DSTAT0 register. This interrupt is not locally maskable and should be tied to the highest possible interrupt level in the system, on an S12 architecture to the XIRQ. See the chapter “Vectors” of the MCU description for details.

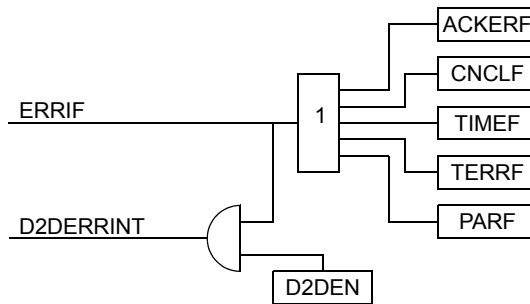

**Figure 96. D2D Internal Interrupts**

### 4.37.5 Initialization Information

During initialization the transfer width, clock divider and timeout value must be set according to the capabilities of the target device before starting any transaction. See the D2D Target specification for details.

### 4.37.6 Application Information

#### 4.37.6.1 Entering low power mode

The D2DI module is typically used on a microcontroller along with an analog companion device containing the D2D target interface and supplying the power. Interface specification does not provide special wires for signalling low power modes to the target device. The CPU should determine when it is time to enter one of the above power modes. The basic flow is as follows:

1. CPU determines there is no more work pending.
2. CPU writes a byte to a register on the analog die using blocking write configuring which mode to enter.
3. Analog die acknowledges that write sending back an acknowledge symbol on the interface.
4. CPU executes WAIT or STOP command.
5. Analog die can enter low-power mode - (S12 needs some more cycles to stack data)

```

; Example shows S12 code
SEI          ; disable interrupts during test
; check is there is work pending?
; if yes, branch off and re-enable interrupt
; else
LDAA        #STOP_ENTRY
STAA        MODE_REG          ; store to the analog die mode reg (use blocking write here)
CLI         ; re-enable right before the STOP instruction
STOP        ; stack and turn off all clocks inc. interface clock
    
```

For wake-up from STOP the basic flow is as follows:

1. Analog die detects a wake-up condition e.g. on a switch input or start bit of a LIN message.
2. Analog die exits Voltage Regulator low-power mode.
3. Analog die asserts the interrupt signal D2DINT.
4. CPU starts clock generation.
5. CPU enters interrupt handler routine.
6. CPU services interrupt and acknowledges the source on the analog die.

**NOTE**

Entering STOP mode or WAIT mode with D2DSWAI asserted, the clock completes the high duty cycle portion and settle at low level.

## 4.38 Serial Peripheral Interface (S12SPIV4)

### 4.38.1 Introduction

The SPI module allows a duplex, synchronous, serial communication between the MCU and peripheral devices. Software can poll the SPI status flags or the SPI operation can be interrupt driven.

#### 4.38.1.1 Glossary of Terms

SPI — Serial Peripheral Interface

SS — Slave Select

SCK — Serial Clock

MOSI — Master Output, Slave Input

MISO — Master Input, Slave Output

MOMI — Master Output, Master Input

SISO — Slave Input, Slave Output

#### 4.38.1.2 Features

The S12SPIV4 includes these distinctive features:

- Master mode and slave mode
- Bi-directional mode
- Slave select output
- Mode fault error flag with CPU interrupt capability
- Double-buffered data register
- Serial clock with programmable polarity and phase
- Control of SPI operation during wait mode

### 4.38.1.3 Modes of Operation

The SPI functions in three modes: run, wait, and stop.

- Run mode  
This is the basic mode of operation.
- Wait mode  
SPI operation in wait mode is a configurable low-power mode, controlled by the SPISWAI bit located in the SPICR2 register. In wait mode, if the SPISWAI bit is clear, the SPI operates like in run mode. If the SPISWAI bit is set, the SPI goes into a power conservative state, with the SPI clock generation turned off. If the SPI is configured as a master, any transmission in progress stops, but is resumed after CPU goes into run mode. If the SPI is configured as a slave, reception and transmission of a byte continues, so the slave stays synchronized to the master.
- Stop mode  
The SPI is inactive in stop mode for reduced power consumption. If the SPI is configured as a master, any transmission in progress stops, but is resumed after CPU goes into run mode. If the SPI is configured as a slave, reception and transmission of a byte continues, so the slave stays synchronized to the master.

This is a high level description only, detailed descriptions of operating modes are contained in [Section 4.38.4.7, "Low Power Mode Options"](#).

#### 4.38.1.4 Block Diagram

Figure 97 gives an overview on the SPI architecture. The main parts of the SPI are status, control and data registers, shifter logic, baud rate generator, master/slave control logic, and port control logic.

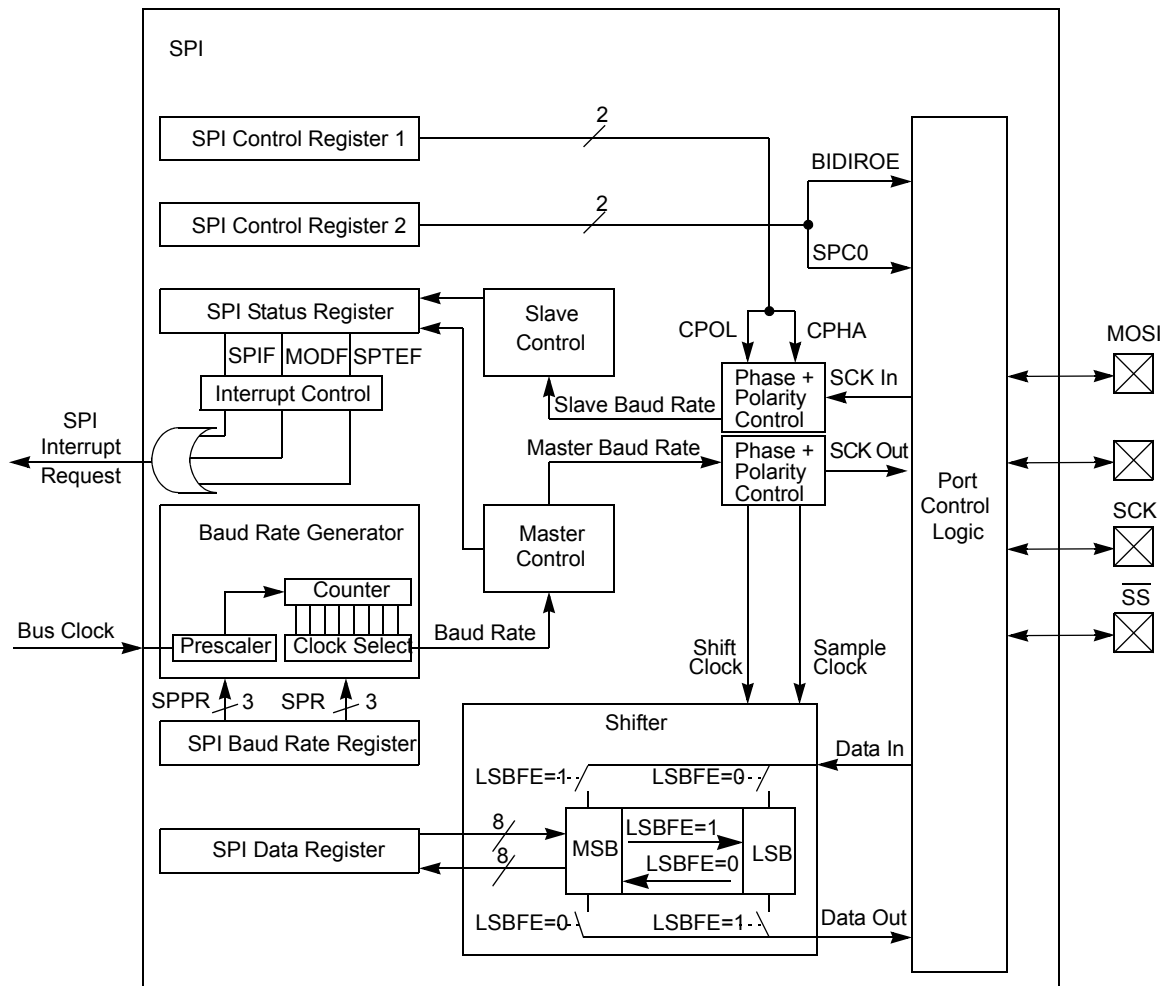

Figure 97. SPI Block Diagram

#### 4.38.2 External Signal Description

This section lists the name and description of all ports including inputs and outputs which do, or may, connect off chip. The S12SPIV4 module has a total of four external pins.

##### 4.38.2.1 MOSI — Master Out/Slave In Pin

This pin is used to transmit data out of the SPI module when it is configured as a master and receive data when it is configured as slave.

##### 4.38.2.2 MISO — Master In/Slave Out Pin

This pin is used to transmit data out of the SPI module when it is configured as a slave and receive data when it is configured as master.

##### 4.38.2.3 $\overline{SS}$ — Slave Select Pin

This pin is used to output the select signal from the SPI module to another peripheral with which a data transfer is to take place when it is configured as a master and it is used as an input to receive the slave select signal when the SPI is configured as slave.

**4.38.2.4 SCK — Serial Clock Pin**

In master mode, this is the synchronous output clock. In slave mode, this is the synchronous input clock.

**4.38.3 Memory Map and Register Definition**

This section provides a detailed description of address space and registers used by the SPI.

**4.38.3.1 Module Memory Map**

The memory map for the S12SPIV4 is given in [Table 405](#).

**Table 405. SPI Register Summary**

Register Name		Bit 7	6	5	4	3	2	1	Bit 0
0x00E8 SPICR1	R	SPIE	SPE	SPTIE	MSTR	CPOL	CPHA	SSOE	LSBFE
	W								
0x00E9 SPICR2	R	0	0	0	MODFEN	BIDIROE	0	SPISWAI	SPC0
	W								
0x00EA SPIBR	R	0	SPPR2	SPPR1	SPPR0	0	SPR2	SPR1	SPR0
	W								
0x00EB SPISR	R	SPIF	0	SPTIEF	MODF	0	0	0	0
	W								
0x00EC Reserved	R								
	W								
0x00ED SPIDR	R	Bit 7	6	5	4	3	2	1	Bit 0
	W								
0x00EE Reserved	R								
	W								
0x00EF Reserved	R								
	W								

**4.38.3.2 Register Descriptions**

This section consists of register descriptions in address order. Each description includes a standard register diagram with an associated figure number. Details of register bit and field function follow the register diagrams, in bit order.

**4.38.3.2.1 SPI Control Register 1 (SPICR1)**

**Table 406. SPI Control Register 1 (SPICR1)**

0x00E8

	7	6	5	4	3	2	1	0
R	SPIE	SPE	SPTIE	MSTR	CPOL	CPHA	SSOE	LSBFE
W								
Reset	0	0	0	0	0	1	0	0

Read: Anytime  
Write: Anytime

**Table 407. SPICR1 Field Descriptions**

Field	Description
7 SPIE	<b>SPI Interrupt Enable Bit</b> — This bit enables SPI interrupt requests, if the SPIF or MODF status flag is set. 0 SPI interrupts disabled. 1 SPI interrupts enabled.
6 SPE	<b>SPI System Enable Bit</b> — This bit enables the SPI system and dedicates the SPI port pins to SPI system functions. If SPE is cleared, SPI is disabled and forced into idle state, status bits in SPISR register are reset. 0 SPI disabled (lower power consumption). 1 SPI enabled, port pins are dedicated to SPI functions.
5 SPTIE	<b>SPI Transmit Interrupt Enable</b> — This bit enables SPI interrupt requests, if the SPTEF flag is set. 0 SPTEF interrupt disabled. 1 SPTEF interrupt enabled.
4 MSTR	<b>SPI Master/Slave Mode Select Bit</b> — This bit selects whether the SPI operates in master or slave mode. Switching the SPI from master to slave or vice versa forces the SPI system into idle state. 0 SPI is in slave mode. 1 SPI is in master mode.
3 CPOL	<b>SPI Clock Polarity Bit</b> — This bit selects an inverted or non-inverted SPI clock. To transmit data between SPI modules, the SPI modules must have identical CPOL values. In master mode, a change of this bit aborts a transmission in progress and force the SPI system into idle state. 0 Active-high clocks selected. In idle state SCK is low. 1 Active-low clocks selected. In idle state SCK is high.
2 CPHA	<b>SPI Clock Phase Bit</b> — This bit is used to select the SPI clock format. In master mode, a change of this bit aborts a transmission in progress and force the SPI system into idle state. 0 Sampling of data occurs at odd edges (1,3,5,...,15) of the SCK clock. 1 Sampling of data occurs at even edges (2,4,6,...,16) of the SCK clock.
1 SSOE	<b>Slave Select Output Enable</b> — The $\overline{SS}$ output feature is enabled only in master mode, if MODFEN is set, by asserting the SSOE as shown in Table 408. In master mode, a change of this bit aborts a transmission in progress and force the SPI system into idle state.
0 LSBFE	<b>LSB-First Enable</b> — This bit does not affect the position of the MSB and LSB in the data register. Reads and writes of the data register always have the MSB in bit 7. In master mode, a change of this bit aborts a transmission in progress and force the SPI system into idle state. 0 Data is transferred most significant bit first. 1 Data is transferred least significant bit first.

**Table 408.  $\overline{SS}$  Input / Output Selection**

MODFEN	SSOE	Master Mode	Slave Mode
0	0	$\overline{SS}$ not used by the SPI	$\overline{SS}$ input
0	1	$\overline{SS}$ not used by the SPI	$\overline{SS}$ input
1	0	$\overline{SS}$ input with MODF feature	$\overline{SS}$ input
1	1	$\overline{SS}$ is slave select output	$\overline{SS}$ input

#### 4.38.3.2.2 SPI Control Register 2 (SPICR2)

**Table 409. SPI Control Register 2 (SPICR2)**

0x00E9

	7	6	5	4	3	2	1	0
R	0	0	0	MODFEN	BIDIROE	0	SPISWAI	SPC0
W								
Reset	0	0	0	0	0	0	0	0

Read: Anytime

Write: Anytime; writes to the reserved bits have no effect

**Table 410. SPICR2 Field Descriptions**

Field	Description
4 MODFEN	<b>Mode Fault Enable Bit</b> — This bit allows the MODF failure to be detected. If the SPI is in master mode and MODFEN is cleared, then the SS port pin is not used by the SPI. In slave mode, the SS is available only as an input regardless of the value of MODFEN. For an overview on the impact of the MODFEN bit on the SS port pin configuration, refer to <a href="#">Table 411</a> . In master mode, a change of this bit aborts a transmission in progress and force the SPI system into idle state. 0 SS port pin is not used by the SPI. 1 SS port pin with MODF feature.
3 BIDIROE	<b>Output Enable in the Bidirectional Mode of Operation</b> — This bit controls the MOSI and MISO output buffer of the SPI, when in bidirectional mode of operation (SPC0 is set). In master mode, this bit controls the output buffer of the MOSI port, and in slave mode it controls the output buffer of the MISO port. In master mode, with SPC0 set, a change of this bit aborts a transmission in progress and force the SPI into idle state. 0 Output buffer disabled. 1 Output buffer enabled.
1 SPISWAI	<b>SPI Stop in Wait Mode Bit</b> — This bit is used for power conservation while in wait mode. 0 SPI clock operates normally in wait mode. 1 Stop SPI clock generation when in wait mode.
0 SPC0	<b>Serial Pin Control Bit 0</b> — This bit enables bidirectional pin configurations as shown in <a href="#">Table 411</a> . In master mode, a change of this bit aborts a transmission in progress and force the SPI system into idle state.

**Table 411. Bidirectional Pin Configurations**

Pin Mode	SPC0	BIDIROE	MISO	MOSI
<b>Master Mode of Operation</b>				
Normal	0	X	Master In	Master Out
Bidirectional	1	0	MISO not used by SPI	Master In
		1		Master I/O
<b>Slave Mode of Operation</b>				
Normal	0	X	Slave Out	Slave In
Bidirectional	1	0	Slave In	MOSI not used by SPI
		1	Slave I/O	

#### 4.38.3.2.3 SPI Baud Rate Register (SPIBR)

**NOTE**

For maximum allowed baud rates, refer to [Section 3.6.2.4, "SPI Timing"](#) in this data sheet.

**Table 412. SPI Baud Rate Register (SPIBR)**

0x00EA

	7	6	5	4	3	2	1	0
R	0	SPPR2	SPPR1	SPPR0	0	SPR2	SPR1	SPR0
W								
Reset	0	0	0	0	0	0	0	0

Read: Anytime

Write: Anytime; writes to the reserved bits have no effect

**Table 413. SPIBR Field Descriptions**

Field	Description
6–4 SPPR[2:0]	<b>SPI Baud Rate Preselection Bits</b> — These bits specify the SPI baud rates as shown in <a href="#">Table 414</a> . In master mode, a change of these bits aborts a transmission in progress and force the SPI system into idle state.
2–0 SPR[2:0]	<b>SPI Baud Rate Selection Bits</b> — These bits specify the SPI baud rates as shown in <a href="#">Table 414</a> . In master mode, a change of these bits aborts a transmission in progress and force the SPI system into idle state.

The baud rate divisor equation is as follows:

$$\text{BaudRateDivisor} = (\text{SPPR} + 1) \cdot 2^{(\text{SPR} + 1)} \quad \text{Eqn. 2}$$

The baud rate can be calculated with the following equation:

$$\text{Baud Rate} = \text{BusClock} / \text{BaudRateDivisor} \quad \text{Eqn. 3}$$

**Table 414. Example SPI Baud Rate Selection (20 MHz Bus Clock)**

SPPR2	SPPR1	SPPR0	SPR2	SPR1	SPR0	Baud Rate Divisor	Baud Rate
0	0	0	0	0	0	2	10.0 MHz
0	0	0	0	0	1	4	5.00 MHz
0	0	0	0	1	0	8	2.50 MHz
0	0	0	0	1	1	16	1.25 MHz
0	0	0	1	0	0	32	625.00 kHz
0	0	0	1	0	1	64	312.50 kHz
0	0	0	1	1	0	128	156.25 kHz
0	0	0	1	1	1	256	78.13 kHz
0	0	1	0	0	0	4	5.00 MHz
0	0	1	0	0	1	8	2.50 MHz
0	0	1	0	1	0	16	1.25 MHz
0	0	1	0	1	1	32	625.00 kHz
0	0	1	1	0	0	64	312.50 kHz
0	0	1	1	0	1	128	156.25 kHz
0	0	1	1	1	0	256	78.13 kHz
0	0	1	1	1	1	512	39.06 kHz
0	1	0	0	0	0	6	3.33 MHz
0	1	0	0	0	1	12	1.66 MHz
0	1	0	0	1	0	24	833.33 kHz
0	1	0	0	1	1	48	416.67 kHz
0	1	0	1	0	0	96	208.33 kHz
0	1	0	1	0	1	192	104.17 kHz
0	1	0	1	1	0	384	52.08 kHz
0	1	0	1	1	1	768	26.04 kHz
0	1	1	0	0	0	8	2.50 MHz

**Table 414. Example SPI Baud Rate Selection (20 MHz Bus Clock) (continued)**

SPPR2	SPPR1	SPPR0	SPR2	SPR1	SPR0	Baud Rate Divisor	Baud Rate
0	1	1	0	0	1	16	1.25 MHz
0	1	1	0	1	0	32	625.00 kHz
0	1	1	0	1	1	64	312.50 kHz
0	1	1	1	0	0	128	156.25 kHz
0	1	1	1	0	1	256	78.13 kHz
0	1	1	1	1	0	512	39.06 kHz
0	1	1	1	1	1	1024	19.53 kHz
1	0	0	0	0	0	10	2.00 MHz
1	0	0	0	0	1	20	1.00 MHz
1	0	0	0	1	0	40	500.00 kHz
1	0	0	0	1	1	80	250.00 kHz
1	0	0	1	0	0	160	125.00 kHz
1	0	0	1	0	1	320	62.50 kHz
1	0	0	1	1	0	640	31.25 kHz
1	0	0	1	1	1	1280	15.63 kHz
1	0	1	0	0	0	12	1.66 kHz
1	0	1	0	0	1	24	833.33 kHz
1	0	1	0	1	0	48	416.67 kHz
1	0	1	0	1	1	96	208.33 kHz
1	0	1	1	0	0	192	104.17 kHz
1	0	1	1	0	1	384	52.08 kHz
1	0	1	1	1	0	768	26.04 kHz
1	0	1	1	1	1	1536	13.02 kHz
1	1	0	0	0	0	14	1.42 MHz
1	1	0	0	0	1	28	714.29 kHz
1	1	0	0	1	0	56	357.14 kHz
1	1	0	0	1	1	112	178.57 kHz
1	1	0	1	0	0	224	89.29 kHz
1	1	0	1	0	1	448	44.64 kHz
1	1	0	1	1	0	896	22.32 kHz
1	1	0	1	1	1	1792	11.16 kHz
1	1	1	0	0	0	16	1.25 MHz
1	1	1	0	0	1	32	625.00 kHz
1	1	1	0	1	0	64	312.50 kHz
1	1	1	0	1	1	128	156.25 kHz
1	1	1	1	0	0	256	39.13 kHz
1	1	1	1	0	1	512	39.06 kHz
1	1	1	1	1	0	1024	19.53 kHz
1	1	1	1	1	1	2048	9.77 kHz

### 4.38.3.2.4 SPI Status Register (SPISR)

**Table 415. SPI Status Register (SPISR)**

0x00EB

	7	6	5	4	3	2	1	0
R	SPIF	0	SPTEF	MODF	0	0	0	0
W								
Reset	0	0	1	0	0	0	0	0

Read: Anytime

Write: Has no effect

**Table 416. SPISR Field Descriptions**

Field	Description
7 SPIF	<b>SPIF Interrupt Flag</b> — This bit is set after a received data byte has been transferred into the SPI data register. This bit is cleared by reading the SPISR register (with SPIF set) followed by a read access to the SPI data register. 0 Transfer not yet complete. 1 New data copied to SPIDR.
5 SPTEF	<b>SPI Transmit Empty Interrupt Flag</b> — If set, this bit indicates the transmit data register is empty. To clear this bit and place data into the transmit data register, SPISR must be read with SPTEF = 1, followed by a write to SPIDR. Any write to the SPI data register without reading SPTEF = 1, is effectively ignored. 0 SPI data register not empty. 1 SPI data register empty.
4 MODF	<b>Mode Fault Flag</b> — This bit is set if the SS input becomes low, while the SPI is configured as a master and mode fault detection is enabled, the MODFEN bit of SPICR2 register is set. Refer to MODFEN bit description in <a href="#">Section 4.38.3.2.2, "SPI Control Register 2 (SPICR2)"</a> . The flag is cleared automatically by a read of the SPI status register (with MODF set) followed by a write to the SPI control register 1. 0 Mode fault has not occurred. 1 Mode fault has occurred.

### 4.38.3.2.5 SPI Data Register (SPIDR)

**Table 417. SPI Data Register (SPIDR)**

0x00ED

	7	6	5	4	3	2	1	0
R	Bit 7	6	5	4	3	2	2	Bit 0
W								
Reset	0	0	0	0	0	0	0	0

Read: Anytime; normally read only when SPIF is set

Write: Anytime

The SPI data register is both the input and output register for SPI data. A write to this register allows a data byte to be queued and transmitted. For an SPI configured as a master, a queued data byte is transmitted immediately after the previous transmission has completed. The SPI transmitter empty flag SPTEF in the SPISR register indicates when the SPI data register is ready to accept new data.

Received data in the SPIDR is valid when SPIF is set. If SPIF is cleared and a byte has been received, the received byte is transferred from the receive shift register to the SPIDR and SPIF is set. If SPIF is set and not serviced, and a second byte has been received, the second received byte is kept as valid byte in the receive shift register until the start of another transmission. The byte in the SPIDR does not change.

If SPIF is set and a valid byte is in the receive shift register, and SPIF is serviced before the start of a third transmission, the byte in the receive shift register is transferred into the SPIDR and SPIF remains set (see Figure 98). If SPIF is set and a valid byte is in the receive shift register, and SPIF is serviced after the start of a third transmission, the byte in the receive shift register has become invalid and is not transferred into the SPIDR (see Figure 99).

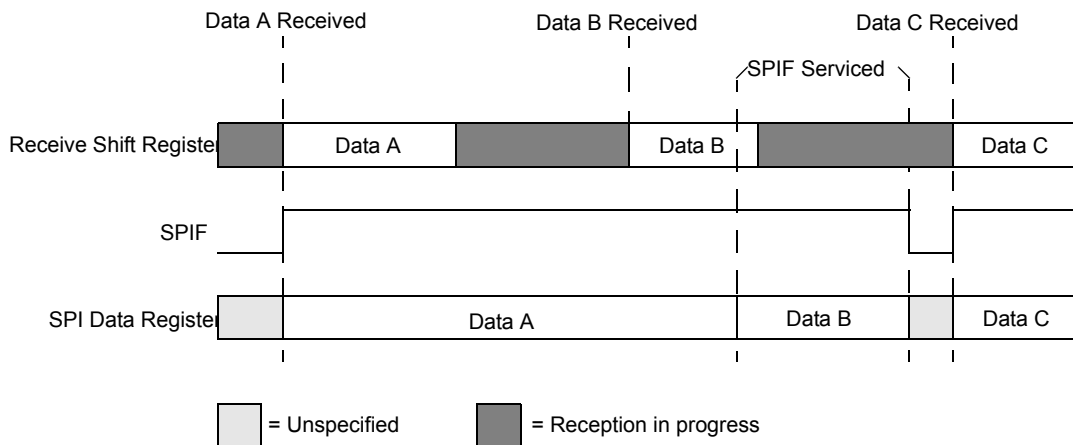

**Figure 98. Reception with SPIF Serviced in Time**

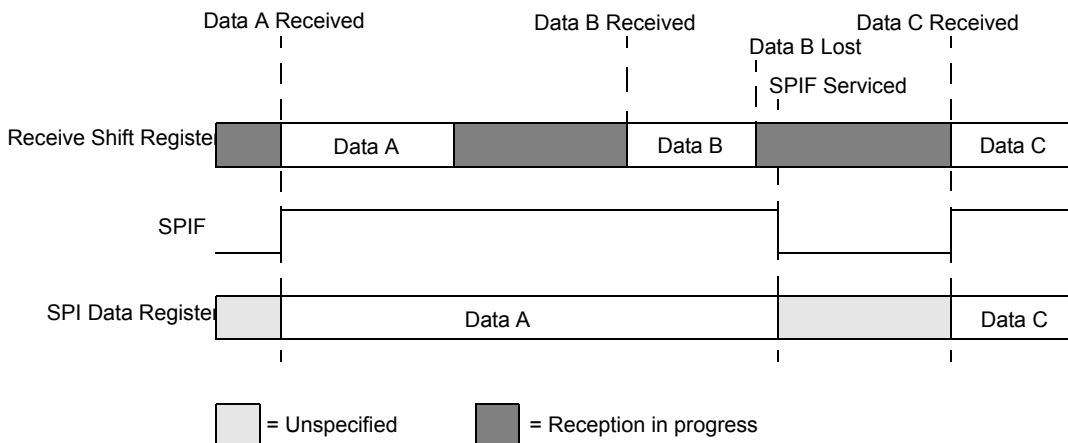

**Figure 99. Reception with SPIF Serviced Too Late**

#### 4.38.4 Functional Description

The SPI module allows a duplex, synchronous, serial communication between the MCU and peripheral devices. Software can poll the SPI status flags or SPI operation can be interrupt driven.

The SPI system is enabled by setting the SPI enable (SPE) bit in SPI control register 1. While SPE is set, the four associated SPI port pins are dedicated to the SPI function as:

- Slave select ( $\overline{SS}$ )
- Serial clock (SCK)
- Master out/slave in (MOSI)
- Master in/slave out (MISO)

The main element of the SPI system is the SPI data register. The 8-bit data register in the master and the 8-bit data register in the slave are linked by the MOSI and MISO pins to form a distributed 16-bit register. When a data transfer operation is performed, this 16-bit register is serially shifted eight bit positions by the S-clock from the master, so data is exchanged between the master and the slave. Data written to the master SPI data register becomes the output data for the slave, and data read from the master SPI data register after a transfer operation is the input data from the slave.

A read of SPISR with SPTEF = 1 followed by a write to SPIDR puts data into the transmit data register. When a transfer is complete and SPIF is cleared, received data is moved into the receive data register. This 8-bit data register acts as the SPI receive data register for reads and as the SPI transmit data register for writes. A single SPI register address is used for reading data from the read data buffer and for writing data to the transmit data register.

The clock phase control bit (CPHA) and a clock polarity control bit (CPOL) in the SPI control register 1 (SPICR1) select one of four possible clock formats to be used by the SPI system. The CPOL bit simply selects a non-inverted or inverted clock. The CPHA bit is used to accommodate two fundamentally different protocols by sampling data on odd numbered SCK edges or on even numbered SCK edges (see [Section 4.38.4.3, "Transmission Formats"](#)).

#### NOTE

A change of CPOL or MSTR bit while there is a received byte pending in the receive shift register destroys the received byte and must be avoided.

The SPI can be configured to operate as a master or as a slave. When the MSTR bit in SPI control register1 is set, master mode is selected, when the MSTR bit is clear, slave mode is selected.

#### 4.38.4.1 Master Mode

#### NOTE

A change of the bits CPOL, CPHA, SSOE, LSBFE, MODFEN, SPC0, or BIDIROE with SPC0 set, SPPR2-SPPR0 and SPR2-SPR0 in master mode aborts a transmission in progress and force the SPI into idle state. The remote slave cannot detect this, therefore the master must ensure the remote slave is returned to idle state.

The SPI operates in master mode when the MSTR bit is set. Only a master SPI module can initiate transmissions. A transmission begins by writing to the master SPI data register. If the shift register is empty, the byte immediately transfers to the shift register. The byte begins shifting out on the MOSI pin under the control of the serial clock.

- Serial clock

The SPR2, SPR1, and SPR0 baud rate selection bits, in conjunction with the SPPR2, SPPR1, and SPPR0 baud rate preselection bits in the SPI baud rate register, control the baud rate generator and determine the speed of the transmission. The SCK pin is the SPI clock output. Through the SCK pin, the baud rate generator of the master controls the shift register of the slave peripheral.

- MOSI, MISO pin

In master mode, the function of the serial data output pin (MOSI) and the serial data input pin (MISO) is determined by the SPC0 and BIDIROE control bits.

- $\overline{SS}$  pin

If MODFEN and SSOE are set, the  $\overline{SS}$  pin is configured as slave select output. The  $\overline{SS}$  output becomes low during each transmission and is high when the SPI is in idle state.

If MODFEN is set and SSOE is cleared, the  $\overline{SS}$  pin is configured as input for detecting mode fault error. If the  $\overline{SS}$  input becomes low, this indicates a mode fault error, where another master tries to drive the MOSI and SCK lines. In this case, the SPI immediately switches to slave mode, by clearing the MSTR bit and also disables the slave output buffer MISO (or SISO in bidirectional mode). The result is all outputs are disabled, and SCK, MOSI, and MISO are inputs. If a transmission is in progress when the mode fault occurs, the transmission is aborted and the SPI is forced into idle state.

This mode fault error also sets the mode fault (MODF) flag in the SPI status register (SPISR). If the SPI interrupt enable bit (SPIE) is set when the MODF flag becomes set, then an SPI interrupt sequence is also requested.

When a write to the SPI data register in the master occurs, there is a half SCK-cycle delay. After the delay, SCK is started within the master. The rest of the transfer operation differs slightly, depending on the clock format specified by the SPI clock phase bit, CPHA, in SPI control register 1 (see [Section 4.38.4.3, "Transmission Formats"](#)).

#### 4.38.4.2 Slave Mode

##### NOTE

When peripherals with duplex capability are used, take care not to simultaneously enable two receivers whose serial outputs drive the same system slave's serial data output line.

The SPI operates in slave mode when the MSTR bit in SPI control register 1 is clear.

- Serial clock  
In slave mode, SCK is the SPI clock input from the master.
- MISO, MOSI pin  
In slave mode, the function of the serial data output pin (MISO) and serial data input pin (MOSI) is determined by the SPC0 bit and BIDIROE bit in SPI control register 2.
- $\overline{SS}$  pin  
The  $\overline{SS}$  pin is the slave select input. Before a data transmission occurs, the  $\overline{SS}$  pin of the slave SPI must be low.  $\overline{SS}$  must remain low until the transmission is complete. If  $\overline{SS}$  goes high, the SPI is forced into idle state.  
The  $\overline{SS}$  input also controls the serial data output pin, if  $\overline{SS}$  is high (not selected), the serial data output pin is high impedance, and, if  $\overline{SS}$  is low, the first bit in the SPI data register is driven out of the serial data output pin. Also, if the slave is not selected ( $\overline{SS}$  is high), then the SCK input is ignored and no internal shifting of the SPI shift register occurs.  
Although the SPI is capable of duplex operation, some SPI peripherals are capable of only receiving SPI data in a slave mode. For these simpler devices, there is no serial data out pin.

As long as no more than one slave device drives the system slave's serial data output line, it is possible for several slaves to receive the same transmission from a master, although the master would not receive return information from all of the receiving slaves.

If the CPHA bit in SPI control register 1 is clear, odd numbered edges on the SCK input cause the data at the serial data input pin to be latched. Even numbered edges cause the value previously latched from the serial data input pin to shift into the LSB or MSB of the SPI shift register, depending on the LSBFE bit.

If the CPHA bit is set, even numbered edges on the SCK input cause the data at the serial data input pin to be latched. Odd numbered edges cause the value previously latched from the serial data input pin to shift into the LSB or MSB of the SPI shift register, depending on the LSBFE bit.

##### NOTE

A change of the CPOL, CPHA, SSOE, LSBFE, MODFEN, SPC0, or BIDIROE bits with SPC0 set in slave mode corrupts a transmission in progress and must be avoided.

When CPHA is set, the first edge is used to get the first data bit onto the serial data output pin. When CPHA is clear and the  $\overline{SS}$  input is low (slave selected), the first bit of the SPI data is driven out of the serial data output pin. After the eighth shift, the transfer is considered complete and the received data is transferred into the SPI data register. To indicate transfer is complete, the SPIF flag in the SPI status register is set.

#### 4.38.4.3 Transmission Formats

During a SPI transmission, data is transmitted (shifted out serially) and received (shifted in serially) simultaneously. The serial clock (SCK) synchronizes shifting and sampling of the information on the two serial data lines. A slave select line allows selection of an individual slave SPI device; slave devices which are not selected do not interfere with SPI bus activities. Optionally, on a master SPI device, the slave select line can be used to indicate multiple-master bus contention.

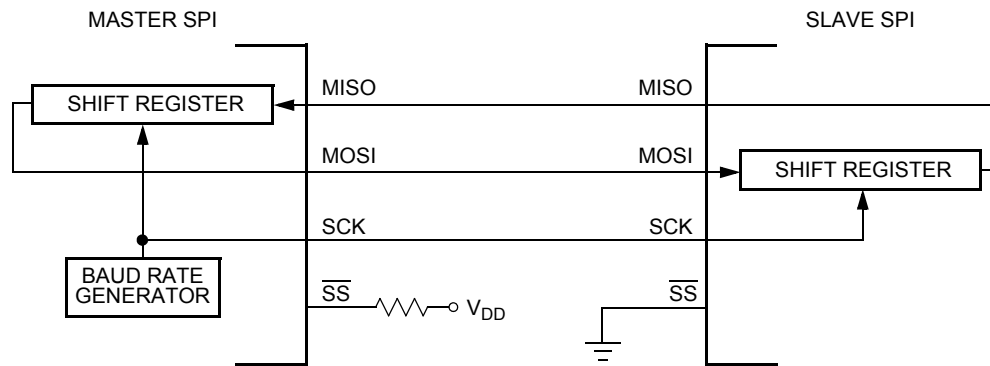

Figure 100. Master/Slave Transfer Block Diagram

#### 4.38.4.3.1 Clock Phase and Polarity Controls

Using two bits in the SPI control register 1, software selects one of four combinations of serial clock phase and polarity. The CPOL clock polarity control bit specifies an active high or low clock and has no significant effect on the transmission format. The CPHA clock phase control bit selects one of two fundamentally different transmission formats.

Clock phase and polarity should be identical for the master SPI device and the communicating slave device. In some cases, the phase and polarity are changed between transmissions to allow a master device to communicate with peripheral slaves having different requirements.

#### 4.38.4.3.2 CPHA = 0 Transfer Format

The first edge on the SCK line is used to clock the first data bit of the slave into the master, and the first data bit of the master into the slave. In some peripherals, the first bit of the slave's data is available at the slave's data out pin as soon as the slave is selected. In this format, the first SCK edge is issued a half cycle after  $\overline{SS}$  has become low.

A half SCK cycle later, the second edge appears on the SCK line. When this second edge occurs, the value previously latched from the serial data input pin is shifted into the LSB or MSB of the shift register, depending on LSBFE bit.

After this second edge, the next bit of the SPI master data is transmitted out of the serial data output pin of the master to the serial input pin on the slave. This process continues for a total of 16 edges on the SCK line, with data being latched on odd numbered edges and shifted on even numbered edges.

Data reception is double buffered. Data is shifted serially into the SPI shift register during the transfer, and is transferred to the parallel SPI data register after the last bit is shifted in. After the 16th (last) SCK edge:

- Data previously in the master SPI data register should now be in the slave data register, and the data in the slave data register should be in the master.
- The SPIF flag in the SPI status register is set, indicating the transfer is complete.

Figure 101 is a timing diagram of an SPI transfer where CPHA = 0. SCK waveforms are shown for CPOL = 0 and CPOL = 1. The diagram may be interpreted as a master or slave timing diagram because the SCK, MISO, and MOSI pins are connected directly between the master and the slave. The MISO signal is the output from the slave and the MOSI signal is the output from the master. The  $\overline{SS}$  pin of the master must be either high or reconfigured as a general purpose output not affecting the SPI.

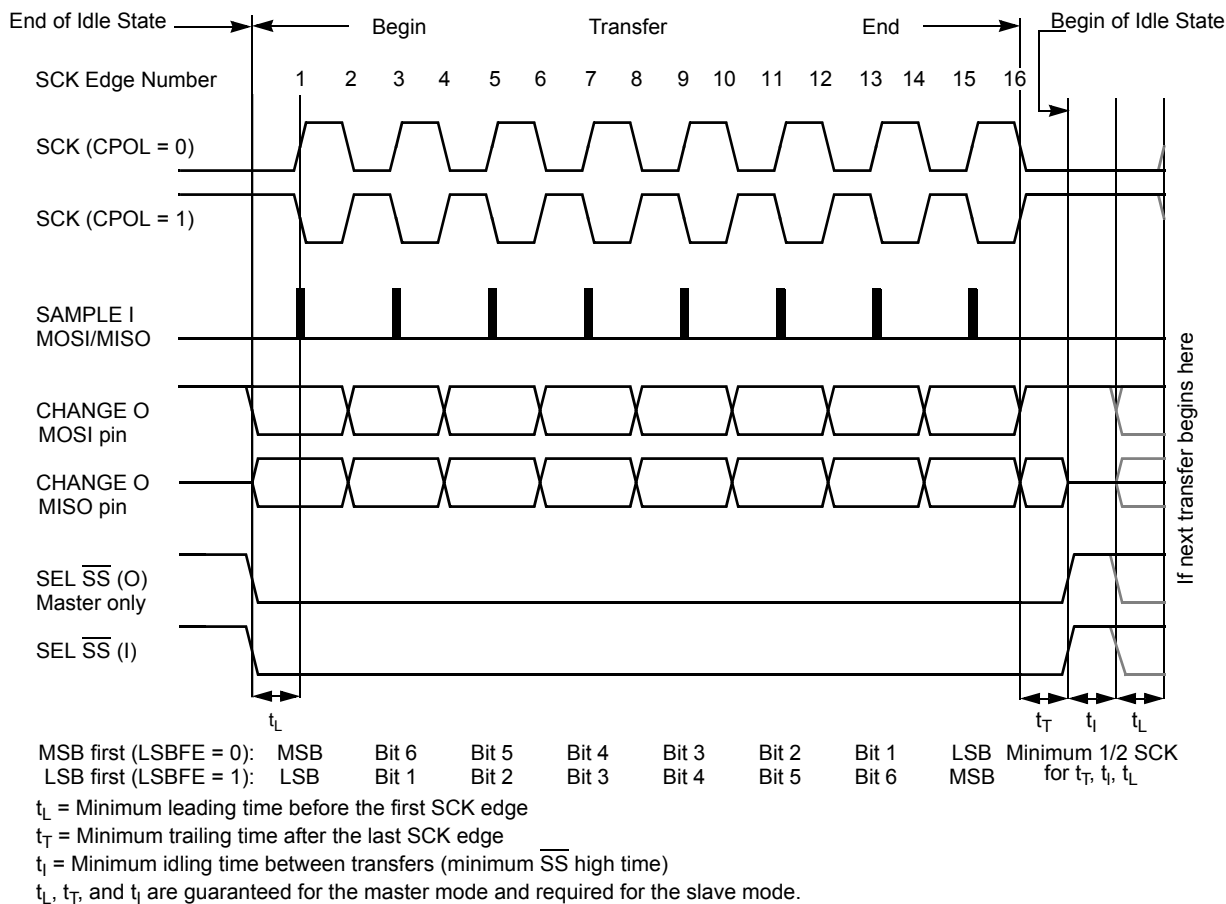

**Figure 101. SPI Clock Format 0 (CPHA = 0)**

In slave mode, if the  $\overline{SS}$  line is not de-asserted between the successive transmissions, then the content of the SPI data register is not transmitted. Instead, the last received byte is transmitted. If the  $\overline{SS}$  line is de-asserted for at least minimum idle time (half SCK cycle) between successive transmissions, then the content of the SPI data register is transmitted.

In master mode, with slave select output enabled the  $\overline{SS}$  line is always de-asserted and reasserted between successive transfers for at least minimum idle time.

**4.38.4.3.3 CPHA = 1 Transfer Format**

Some peripherals require the first SCK edge before the first data bit becomes available at the data out pin, the second edge clocks data into the system. In this format, the first SCK edge is issued by setting the CPHA bit at the beginning of the 8-cycle transfer operation. The first edge of SCK occurs immediately after the half SCK clock cycle synchronization delay. This first edge commands the slave to transfer its first data bit to the serial data input pin of the master. A half SCK cycle later, the second edge appears on the SCK pin. This is the latching edge for both the master and slave.

When the third edge occurs, the value previously latched from the serial data input pin is shifted into the LSB or MSB of the SPI shift register, depending on LSBFE bit. After this edge, the next bit of the master data is coupled out of the serial data output pin of the master to the serial input pin on the slave.

This process continues for a total of 16 edges on the SCK line with data being latched on even numbered edges and shifting taking place on odd numbered edges. Data reception is double buffered, data is serially shifted into the SPI shift register during the transfer and is transferred to the parallel SPI data register after the last bit is shifted in. After the 16th SCK edge:

- Data previously in the SPI data register of the master is now in the data register of the slave, and data in the data register of the slave is in the master.
- The SPIF flag bit in SPISR is set indicating the transfer is complete.

Figure 102 shows two clocking variations for CPHA = 1. The diagram may be interpreted as a master or slave timing diagram because the SCK, MISO, and MOSI pins are connected directly between the master and the slave. The MISO signal is the output from the slave, and the MOSI signal is the output from the master. The  $\overline{SS}$  line is the slave select input to the slave. The  $\overline{SS}$  pin of the master must be either high or reconfigured as a general-purpose output not affecting the SPI.

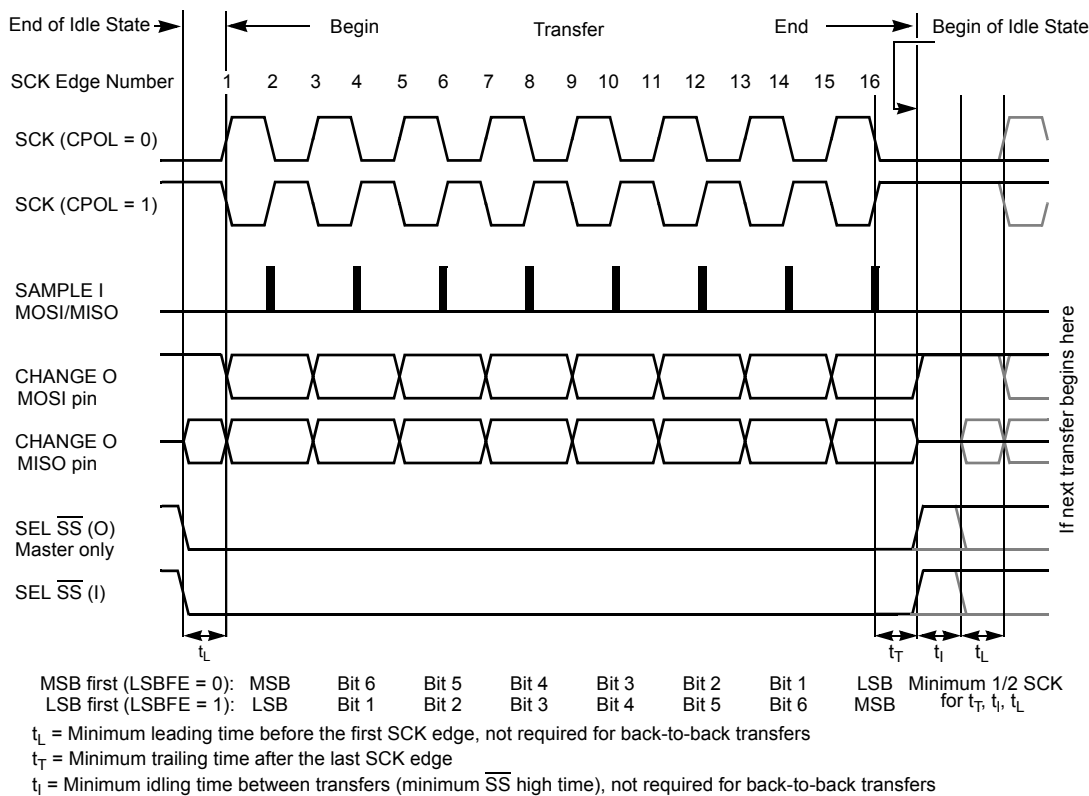

Figure 102. SPI Clock Format 1 (CPHA = 1)

The  $\overline{SS}$  line can remain active low between successive transfers (can be tied low at all times). This format is sometimes preferred in systems having a single fixed master and a single slave which drives the MISO data line.

- Back-to-back transfers in master mode

In master mode, if a transmission has completed and a new data byte is available in the SPI data register, this byte is sent out immediately without a trailing and minimum idle time.

The SPI interrupt request flag (SPIF) is common to both the master and slave modes. SPIF gets set one half SCK cycle after the last SCK edge.

#### 4.38.4.4 SPI Baud Rate Generation

**NOTE**

For maximum allowed baud rates, refer to [Section 3.6.2.4, "SPI Timing"](#) in this data sheet.

Baud rate generation consists of a series of divider stages. Six bits in the SPI baud rate register (SPPR2, SPPR1, SPPR0, SPR2, SPR1, and SPR0) determine the divisor to the SPI module clock which results in the SPI baud rate.

The SPI clock rate is determined by the product of the value in the baud rate preselection bits (SPPR2–SPPR0) and the value in the baud rate selection bits (SPR2–SPR0). The module clock divisor equation is shown in [Equation 4](#).

$$\text{BaudRateDivisor} = (\text{SPPR} + 1) \cdot 2^{(\text{SPR} + 1)}$$

Eqn. 4

When all bits are clear (the default condition), the SPI module clock is divided by 2. When the selection bits (SPR2–SPR0) are 001 and the preselection bits (SPPR2–SPPR0) are 000, the module clock divisor becomes 4. When the selection bits are 010, the module clock divisor becomes 8, etc.

When the preselection bits are 001, the divisor determined by the selection bits is multiplied by 2. When the preselection bits are 010, the divisor is multiplied by 3, etc. See Table 414 for baud rate calculations for all bit conditions, based on a 20 MHz bus clock. The two sets of selects allows the clock to be divided by a non-power of two to achieve other baud rates such as divide by 6, divide by 10, etc.

The baud rate generator is activated only when the SPI is in master mode and a serial transfer is taking place. In the other cases, the divider is disabled to decrease I<sub>DD</sub> current.

**4.38.4.5 Special Features**

**4.38.4.5.1  $\overline{SS}$  Output**

**NOTE**

Care must be taken when using the  $\overline{SS}$  output feature in a multi master system because the mode fault feature is not available for detecting system errors between masters.

The  $\overline{SS}$  output feature automatically drives the  $\overline{SS}$  pin low during transmission to select external devices and drives it high during idle to deselect external devices. When  $\overline{SS}$  output is selected, the  $\overline{SS}$  output pin is connected to the  $\overline{SS}$  input pin of the external device. The  $\overline{SS}$  output is available only in master mode during normal SPI operation by asserting SSOE and MODFEN bit as shown in Table 408. The mode fault feature is disabled while  $\overline{SS}$  output is enabled.

**4.38.4.5.2 Bidirectional Mode (MOMI or SISO)**

**NOTE**

In bidirectional master mode, with mode fault enabled, both MISO and MOSI data pins can be occupied by the SPI, though MOSI is normally used for transmissions in bidirectional mode, and MISO is not used by the SPI. If a mode fault occurs, the SPI is automatically switched to slave mode. In this case, MISO becomes occupied by the SPI and MOSI is not used. This must be considered if the MISO pin is used for another purpose.

The bidirectional mode is selected when the SPC0 bit is set in SPI control register 2 (see Table 418). In this mode, the SPI uses only one serial data pin for the interface with external device(s). The MSTR bit decides which pin to use. The MOSI pin becomes the serial data I/O (MOMI) pin for the master mode, and the MISO pin becomes serial data I/O (SISO) pin for the slave mode. The MISO pin in master mode and MOSI pin in slave mode are not used by the SPI.

**Table 418. Normal Mode and Bidirectional Mode**

When SPE = 1	Master Mode MSTR = 1	Slave Mode MSTR = 0
Normal Mode SPC0 = 0		
Bidirectional Mode SPC0 = 1		

The direction of each serial I/O pin depends on the BIDIROE bit. If the pin is configured as an output, serial data from the shift register is driven out on the pin. The same pin is also the serial input to the shift register.

- The  $\overline{\text{SCK}}$  is output for the master mode and input for the slave mode.
- The  $\overline{\text{SS}}$  is the input or output for the master mode, and it is always the input for the slave mode.
- The bidirectional mode does not affect  $\overline{\text{SCK}}$  and  $\overline{\text{SS}}$  functions.

#### 4.38.4.6 Error Conditions

The SPI has one error condition:

- Mode fault error

##### 4.38.4.6.1 Mode Fault Error

#### NOTE

If a mode fault error occurs and a received data byte is pending in the receive shift register, this data byte is lost.

If the  $\overline{\text{SS}}$  input becomes low while the SPI is configured as a master, it indicates a system error where more than one master may be trying to drive the MOSI and  $\overline{\text{SCK}}$  lines simultaneously. This condition is not permitted in normal operation. The  $\text{MODF}$  bit in the SPI status register is set automatically, provided the  $\text{MODFEN}$  bit is set.

In the special case where the SPI is in master mode and  $\text{MODFEN}$  bit is cleared, the  $\overline{\text{SS}}$  pin is not used by the SPI. In this case, the mode fault error function is inhibited and  $\text{MODF}$  remains cleared. In case the SPI system is configured as a slave, the  $\overline{\text{SS}}$  pin is a dedicated input pin. Mode fault error doesn't occur in slave mode.

If a mode fault error occurs, the SPI is switched to slave mode, with the exception that the slave output buffer is disabled. So  $\overline{\text{SCK}}$ ,  $\overline{\text{MISO}}$ , and  $\overline{\text{MOSI}}$  pins are forced to be high-impedance inputs, to avoid any possibility of conflict with another output driver. A transmission in progress is aborted and the SPI is forced into idle state.

If the mode fault error occurs in the bidirectional mode for a SPI system configured in master mode, output enable of the  $\overline{\text{MOSI}}$  (MOSI in bidirectional mode) is cleared if it was set. No mode fault error occurs in the bidirectional mode for SPI system configured in slave mode.

The mode fault flag is cleared automatically by a read of the SPI status register (with  $\text{MODF}$  set), followed by a write to the SPI control register 1. If the mode fault flag is cleared, the SPI becomes a normal master or slave again.

#### 4.38.4.7 Low Power Mode Options

##### 4.38.4.7.1 SPI in Run Mode

In run mode with the SPI system enable ( $\text{SPE}$ ) bit in the SPI control register clear, the SPI system is in a low-power, disabled state. SPI registers remain accessible, but clocks to the core of this module are disabled.

##### 4.38.4.7.2 SPI in Wait Mode

#### NOTE

Care must be taken when expecting data from a master while the slave is in wait or stop mode. Even though the shift register continues to operate, the rest of the SPI is shut down (i.e., a  $\text{SPIF}$  interrupt is **not** generated until exiting stop or wait mode). Also, the byte from the shift register is not copied into the  $\text{SPIDR}$  register until after the slave SPI has exited wait or stop mode. In slave mode, a received byte pending in the receive shift register is lost when entering wait or stop mode. An  $\text{SPIF}$  flag and  $\text{SPIDR}$  copy is generated only if wait mode is entered or exited during a transmission. If the slave enters wait mode in idle mode and exits wait mode in idle mode, neither a  $\text{SPIF}$  nor a  $\text{SPIDR}$  copy occurs.

SPI operation in wait mode depends upon the state of the  $\text{SPISWAI}$  bit in SPI control register 2.

- If  $\text{SPISWAI}$  is clear, the SPI operates normally when the CPU is in wait mode
- If  $\text{SPISWAI}$  is set, SPI clock generation ceases and the SPI module enters a power conservation state when the CPU is in wait mode.
- If  $\text{SPISWAI}$  is set and the SPI is configured for master, any transmission and reception in progress stops at wait mode entry. The transmission and reception resumes when the SPI exits wait mode.

- If SPISWAI is set and the SPI is configured as a slave, any transmission and reception in progress continues if the SCK continues to be driven from the master. This keeps the slave synchronized to the master and the SCK.
- If the master transmits several bytes while the slave is in wait mode, the slave continues to send out bytes consistent with the operation mode at the start of wait mode (i.e., if the slave is currently sending its SPIDR to the master, it continues to send the same byte. Else, if the slave is currently sending the last received byte from the master, it continues to send each previous master byte).

#### 4.38.4.7.3 SPI in Stop Mode

Stop mode is dependent on the system. The SPI enters stop mode when the module clock is disabled (held high or low). If the SPI is in master mode and exchanging data when the CPU enters stop mode, the transmission is frozen until the CPU exits stop mode. After stop, data to and from the external SPI is exchanged correctly. In slave mode, the SPI stays synchronized with the master. The stop mode is not dependent on the SPISWAI bit.

#### 4.38.4.7.4 Reset

The reset values of registers and signals are described in [Section 4.28.2, "Memory Map and Registers"](#), which details the registers and their bit fields.

- If a data transmission occurs in slave mode after reset without a write to SPIDR, it transmits garbage, or the byte last received from the master before the reset.
- Reading from the SPIDR after reset always reads a byte of zeros.

#### 4.38.4.7.5 Interrupts

The S12SPIV4 only originates interrupt requests when the SPI is enabled (SPE bit in SPICR1 set). The following is a description of how the S12SPIV4 makes a request, and how the MCU should acknowledge this request. The interrupt vector offset and interrupt priority are chip dependent. The interrupt flags MODF, SPIF, and SPTEF are logically ORED to generate an interrupt request.

##### 4.38.4.7.5.1 MODF

MODF occurs when the master detects an error on the  $\overline{SS}$  pin. The master SPI must be configured for the MODF feature (see [Table 408](#)). After MODF is set, the current transfer is aborted and the following bit is changed:

- MSTR = 0, The master bit in SPICR1 resets.

The MODF interrupt is reflected in the status register MODF flag. Clearing the flag also clears the interrupt. This interrupt stays active while the MODF flag is set. MODF has an automatic clearing process which is described in [Section 4.38.3.2.4, "SPI Status Register \(SPISR\)"](#).

##### 4.38.4.7.5.2 SPIF

SPIF occurs when new data has been received and copied to the SPI data register. After SPIF is set, it does not clear until it is serviced. SPIF has an automatic clearing process, which is described in [Section 4.38.3.2.4, "SPI Status Register \(SPISR\)"](#).

##### 4.38.4.7.5.3 SPTEF

SPTEF occurs when the SPI data register is ready to accept new data. After SPTEF is set, it does not clear until it is serviced. SPTEF has an automatic clearing process, which is described in [Section 4.38.3.2.4, "SPI Status Register \(SPISR\)"](#).

## 5 Packaging

### 5.1 Package Dimensions

For the most current package revision, visit [www.freescale.com](http://www.freescale.com) and perform a keyword search using the “98A” listed below.

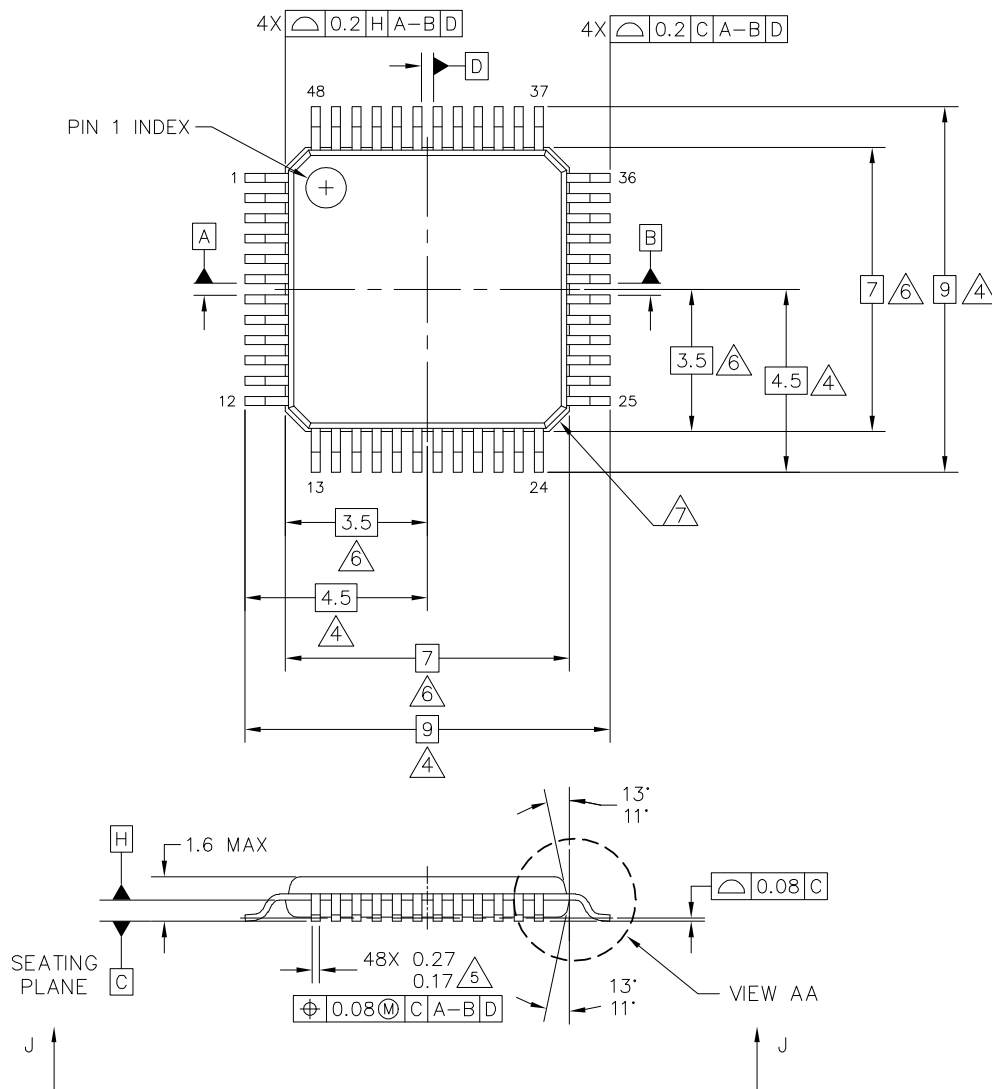

© FREESCALE SEMICONDUCTOR, INC. ALL RIGHTS RESERVED.	<b>MECHANICAL OUTLINE</b>	PRINT VERSION NOT TO SCALE	
TITLE: 48 LEAD LQFP, 7X7X1.4 PKG, 0.5 PITCH, 4.5X4.5 EXPOSED PAD		DOCUMENT NO: 98ASA00173D	REV: A
		CASE NUMBER: 2003-02	30 JUN 2011
		STANDARD: JEDEC MS-026 BBC	

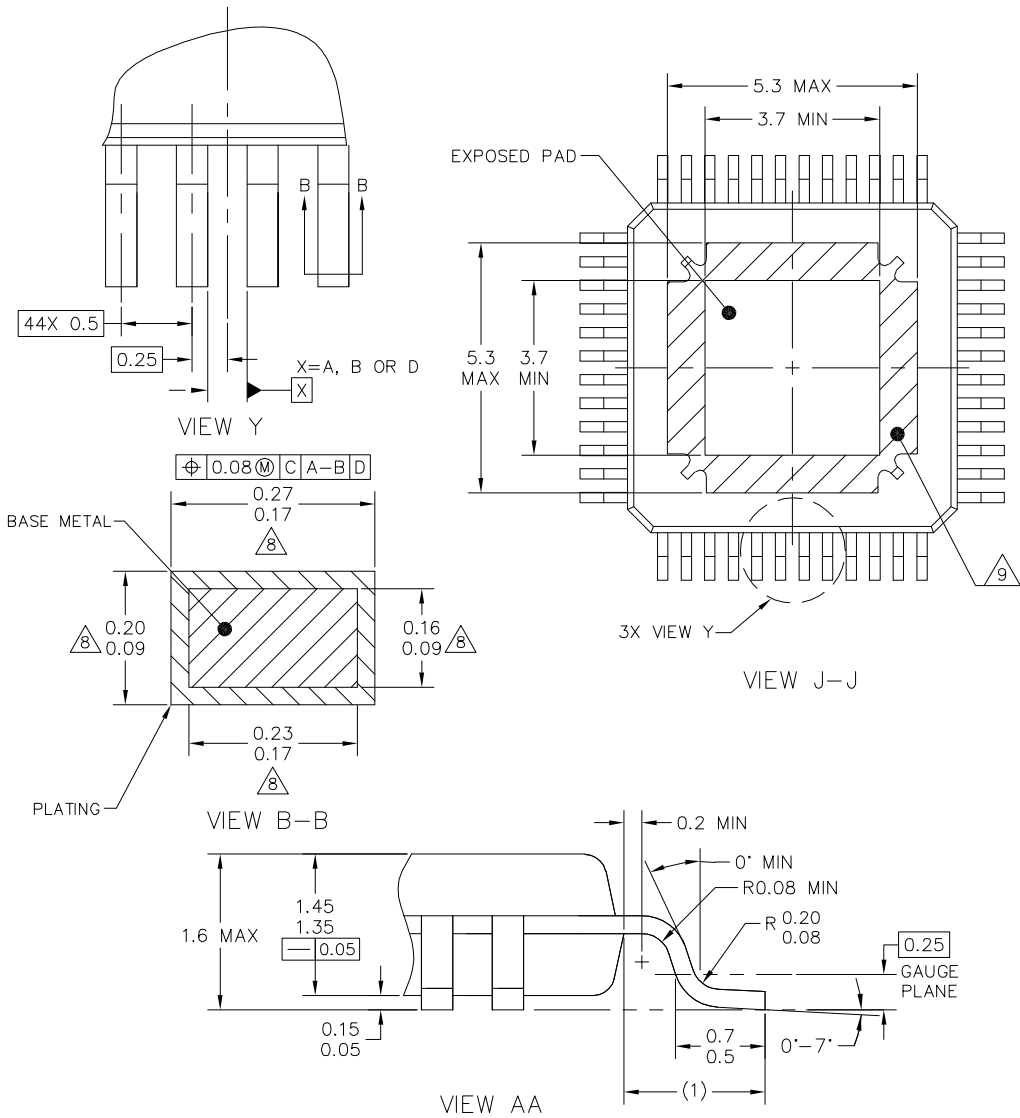

© FREESCALE SEMICONDUCTOR, INC. ALL RIGHTS RESERVED.	<b>MECHANICAL OUTLINE</b>	PRINT VERSION NOT TO SCALE
<b>TITLE:</b> 48 LEAD LQFP, 7X7X1.4 PKG, 0.5 PITCH, 4.5X4.5 EXPOSED PAD	DOCUMENT NO: 98ASA00173D	REV: A
	CASE NUMBER: 2003-02	30 JUN 2011
	STANDARD: JEDEC MS-026 BBC	

NOTES:

1. DIMENSIONS ARE IN MILLIMETERS.
2. DIMENSIONING AND TOLERANCING PER ASME Y14.5M-1994.
3. DATUMS A, B AND D TO BE DETERMINED AT DATUM PLANE H.
4. DIMENSION TO BE DETERMINED AT SEATING PLANE C.
5. THIS DIMENSION DOES NOT INCLUDE DAMBAR PROTRUSION. ALLOWABLE DAMBAR PROTRUSION SHALL NOT CAUSE THE LEAD WIDTH TO EXCEED THE UPPER LIMIT BY MORE THAN 0.08MM AT MAXIMUM MATERIAL CONDITION. DAMBAR CANNOT BE LOCATED ON THE LOWER RADIUS OR THE FOOT. MINIMUM SPACE BETWEEN PROTRUSION AND ADJACENT LEAD SHALL NOT BE LESS THAN 0.07MM.
6. THIS DIMENSION DOES NOT INCLUDE MOLD PROTRUSION. ALLOWABLE PROTRUSION IS 0.25MM PER SIDE. THIS DIMENSION IS MAXIMUM PLASTIC BODY SIZE DIMENSION INCLUDING MOLD MISMATCH.
7. EXACT SHAPE OF EACH CORNER IS OPTIONAL.
8. THESE DIMENSIONS APPLY TO THE FLAT SECTION OF THE LEAD BETWEEN 0.1MM AND 0.25MM FROM THE LEAD TIP.
9. HATCHED AREA TO BE KEEP OUT ZONE FOR PCB ROUTING.

© FREESCALE SEMICONDUCTOR, INC. ALL RIGHTS RESERVED.	<b>MECHANICAL OUTLINE</b>	PRINT VERSION NOT TO SCALE	
TITLE: 48 LEAD LQFP, 7X7X1.4 PKG, 0.5 PITCH, 4.5X4.5 EXPOSED PAD	DOCUMENT NO: 98ASA00173D	REV: A	
	CASE NUMBER: 2003-02	30 JUN 2011	
	STANDARD: JEDEC MS-026 BBC		

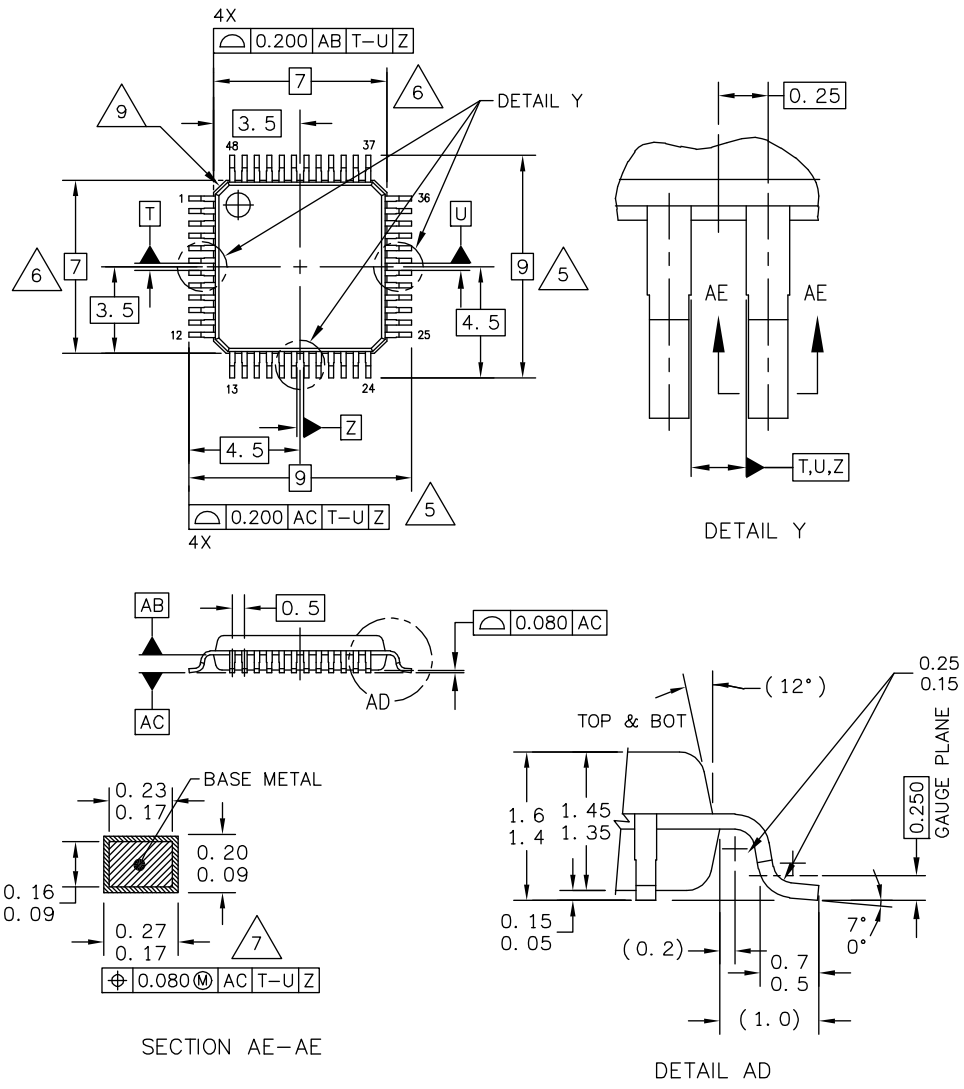

© FREESCALE SEMICONDUCTOR, INC. ALL RIGHTS RESERVED.	<b>MECHANICAL OUTLINE</b>	PRINT VERSION NOT TO SCALE
TITLE: LQFP, 48 LEAD, 0.50 PITCH (7.0 X 7.0 X 1.4)	DOCUMENT NO: 98ASH00962A	REV: G
	CASE NUMBER: 932-03	14 APR 2005
	STANDARD: JEDEC MS-026-BBC	

NOTES:

1. DIMENSIONS AND TOLERANCING PER ASME Y14.5M-1994.
2. CONTROLLING DIMENSION: MILLIMETER.
3. DATUM PLANE AB IS LOCATED AT BOTTOM OF LEAD AND IS COINCIDENT WITH THE LEAD WHERE THE LEAD EXITS THE PLASTIC BODY AT THE BOTTOM OF THE PARTING LINE.
4. DATUMS T, U, AND Z TO BE DETERMINED AT DATUM PLANE AB.
5. DIMENSIONS TO BE DETERMINED AT SEATING PLANE AC.
6. DIMENSIONS DO NOT INCLUDE MOLD PROTRUSION. ALLOWABLE PROTRUSION IS 0.250 PER SIDE. DIMENSIONS DO INCLUDE MOLD MISMATCH AND ARE DETERMINED AT DATUM PLANE AB.
7. THIS DIMENSION DOES NOT INCLUDE DAMBAR PROTRUSION. DAMBAR PROTRUSION SHALL NOT CAUSE THE LEAD WIDTH TO EXCEED 0.350.
8. MINIMUM SOLDER PLATE THICKNESS SHALL BE 0.0076.
9. EXACT SHAPE OF EACH CORNER IS OPTIONAL.

© FREESCALE SEMICONDUCTOR, INC. ALL RIGHTS RESERVED.	<b>MECHANICAL OUTLINE</b>	PRINT VERSION NOT TO SCALE	
TITLE: LQFP, 48 LEAD, 0.50 PITCH (7.0 X 7.0 X 1.4)	DOCUMENT NO: 98ASH00962A	REV: G	
	CASE NUMBER: 932-03	14 APR 2005	
	STANDARD: JEDEC MS-026-BBC		

## 6 Revision History

Revision	Date	Description
1.0	05/2010	<ul style="list-style-type: none"> <li>Initial release.</li> </ul>
2.0	7/2010	<ul style="list-style-type: none"> <li>MM912F634Cxxxx (Revision C) Introduced</li> <li>MM912F634Cxxxx (Revision C) Lx Input Threshold / Hysteresis Limit added. See Table 23, Static Electrical Characteristics - High Voltage Inputs - Lx</li> <li><math>V_{DDXSTOP}</math> minimum value deleted. See Table 17, Static Electrical Characteristics - Voltage Regulator 5.0 V (VDDX)</li> <li><math>I_{VDDLIMXSTOP}</math> ratings changed. See Table 17, Static Electrical Characteristics - Voltage Regulator 5.0 V (VDDX)</li> <li><math>I_{VDDLIMRUN}</math> minimum value deleted for all values of <math>T_J</math>. See Table 18, Static Electrical Characteristics - Voltage Regulator 2.5 V (VDD)</li> <li><math>I_{VDDLIMSTOP}</math> minimum value deleted. See Table 18, Static Electrical Characteristics - Voltage Regulator 2.5 V (VDD)</li> <li>TSg typical value changed to 9.17 mV/k. See Table 27, Static Electrical Characteristics - Temperature Sensor - TSENSE</li> <li>Deleted devices MM912F634BC1AE, MM912F634BV2AE, MM912F634BC2AE, MM912F634BV3AE, MM912F634BC3AE, MM912F634CC1AE, MM912F634CC2AE, MM912F634CV3AE, MM912F634CC3AE from Table 1, Ordering Information, as well as references to these devices in sections 3.5, 3.6 &amp; 3.7</li> <li>Deleted "Data Flash" column in Table 1, Ordering Information, since this feature is not available for the MM912F634</li> <li>Deleted all references to Analog Options "A3" &amp; "A4" in Section 4.1.3, Analog Die Options</li> <li>Changed Analog Option designations from "A1" &amp; "A2" to "1" &amp; "2", respectively, in Table 1, Ordering Information, and Table 2, Analog Options</li> <li>Clarified instructions on use of unused pins in devices with Analog Option "2"</li> <li>Changed MM912F634Cxxxx Lx High Detection Threshold <math>V_{THH(min)}</math> from 2.7 V to 2.6 V for the range <math>7.0 V \leq VSUP \leq 27 V</math>. Changed max &amp; typical Hysteresis <math>V_{HYS}</math> for MM912F634Cxxxx. Applied these new values to the full range of <math>5.5 V \leq VSUP \leq 27 V</math>. See Table 19, Static Electrical Characteristics - High Voltage Inputs - Lx</li> <li>Added separate HBM ESD rating (<math>V_{HBM}</math>) for HSx pins of +/-3000V. See Table 46, ESD and Latch-up Protection Characteristics</li> </ul>
3.0	10/2010	<ul style="list-style-type: none"> <li>Added MM912F634CV2AP to the ordering information</li> <li>Updated to standard form and style</li> <li>Added the 98ASA00173D (48-PIN LQFP) package drawing to the Packaging section</li> <li>Added symbol <math>f_{BUSMAX}</math> to Max. Bus Frequency (MHz) column in Table 1.</li> <li>Replaced all references to 20 MHz bus frequency with <math>f_{BUSMAX}</math>, and added a note referring to Table 1. See Table 8 - Operating Conditions, Table 9 - Supply Currents, Table 28 - Dynamic Electrical Characteristics - Die to Die Interface - D2D.</li> <li>Added reference to 16 MHz maximum CPU Bus Frequency for MM912F634CV2AP to section 4.25.1.1 (MM912F634 - MCU Die Overview: Features)</li> <li>Changed Baud Rate data to reflect a 20 MHz Bus Clock in Table 409 - Example SPI Baud Rate Selection.</li> </ul>
4.0	10/2010	<ul style="list-style-type: none"> <li>Removed part number MM912F634BV1AE from data sheet.</li> </ul>
5.0	11/2010	<ul style="list-style-type: none"> <li>Corrected several typos throughout the document - No technical changes</li> </ul>
6.0	9/2012	<ul style="list-style-type: none"> <li>Added MM912F634DV1AE, MM912F634DV2AE, MM912F634DV2AP to the ordering information.</li> <li>Redefined <math>R_{\theta JA}</math> for both LQFP packages.</li> </ul>
7.0	5/2013	<ul style="list-style-type: none"> <li>Updated <a href="#">Package Thermal Resistance - LQFP48-EP</a> and <a href="#">Package Thermal Resistance - LQFP48</a> to add JEDEC board information.</li> <li>Added <a href="#">Section 4.36.3.4.9, "Flash Option Register (FOPT)"</a>, and fixed associated links.</li> </ul>

Revision	Date	Description
8.0	5/2015	<ul style="list-style-type: none"> <li>• Changed Low-side frequency + added condition + added note guaranteed by design</li> <li>• Corrected typo <math>V_{LVR}</math> and <math>V_{ROV}</math></li> <li>• Added <a href="#">Section 4.12.6, "Low-side Driver in Reverse Polarity"</a></li> <li>• Added the sentence in the general description to <a href="#">Section 4.25, "MM912F634 - Analog Die Trimming"</a></li> <li>• Removed the Note at beginning of 4.25.1.1</li> <li>• Added explanation on SLPBG_Lock bit (4.25.1.2.3) + note to refer to errata</li> <li>• Added comment regarding D2D not bonded in <a href="#">Section 4.37.2.2, "D2DDAT[7:4]"</a></li> <li>• Added note <sup>(199)</sup></li> <li>• Updated case outline</li> <li>• Removed the C part numbers in <a href="#">1 Ordering Information</a> (obsolete)</li> <li>• Reformatted document to new form and style</li> </ul>
9.0	6/2015	<ul style="list-style-type: none"> <li>• Updated the max. value for Output Drain-to-Source On resistance in <a href="#">Table 15</a></li> <li>• Corrected references in Revision History</li> <li>• Updated module names.</li> </ul>

**How to Reach Us:**

**Home Page:**  
freescale.com

**Web Support:**  
freescale.com/support

Information in this document is provided solely to enable system and software implementers to use Freescale products. There are no express or implied copyright licenses granted hereunder to design or fabricate any integrated circuits based on the information in this document.

Freescale reserves the right to make changes without further notice to any products herein. Freescale makes no warranty, representation, or guarantee regarding the suitability of its products for any particular purpose, nor does Freescale assume any liability arising out of the application or use of any product or circuit, and specifically disclaims any and all liability, including without limitation consequential or incidental damages. "Typical" parameters that may be provided in Freescale data sheets and/or specifications can and do vary in different applications, and actual performance may vary over time. All operating parameters, including "typicals," must be validated for each customer application by customer's technical experts. Freescale does not convey any license under its patent rights nor the rights of others. Freescale sells products pursuant to standard terms and conditions of sale, which can be found at the following address: [freescale.com/SalesTermsandConditions](http://freescale.com/SalesTermsandConditions).

Freescale and the Freescale logo, are trademarks of Freescale Semiconductor, Inc., Reg. U.S. Pat. & Tm. Off. SMARTMOS is a trademark of Freescale Semiconductor, Inc. All other product or service names are the property of their respective owners.

© 2015 Freescale Semiconductor, Inc.

Document Number: MM912F634  
Rev. 9.0  
6/2015

## Looking for pricing, stock, or lifecycle information?

Click below to explore more details on WIN SOURCE:

 [View MM912F634BV1AE on WIN SOURCE](#)

 [NXP / Nexperia Information](#)

## Optimize Your Supply Chain with WIN SOURCE Solutions

-  Global Sourcing Solution
-  Obsolete Management
-  Cost Control Management
-  Shortage Management
-  Alternative Solution
-  Excess Inventory Management