



**THE DATASHEET OF  
MP2388GQEU-Z**



## DESCRIPTION

The MP2388 is a high-frequency, synchronous, rectified, step-down, switch-mode converter with built-in, internal power MOSFETs. It offers a very compact solution that achieves 1A of continuous output current over a wide input supply range with excellent load and line regulation. Current mode operation provides fast transient response and eases loop stabilization.

Full protection features include over-current protection (OCP) and thermal shutdown.

The MP2388 requires a minimum number of readily available, standard, external components and is available in a space-saving QFN-8 (1.5mmx2.5mm) package.

## FEATURES

- Wide 4.5V to 21V Operating Input Range
- 1A Load Current
- 110mΩ/50mΩ Low  $R_{DS(ON)}$  Internal Power MOSFETs
- Low Quiescent Current
- High-Efficiency Synchronous Mode Operation
- Fixed 2MHz Switching Frequency
- AAM Power Save Mode
- Internal Soft Start
- Over-Current Protection (OCP) and Hiccup
- Thermal Shutdown
- Output Adjustable from 0.8V
- Available in a QFN-8 (1.5mmx2.5mm) Package

## APPLICATIONS

- Notebook Systems and I/O Power
- Digital Set-Top Boxes
- Flat-Panel Televisions and Monitors

All MPS parts are lead-free, halogen-free, and adhere to the RoHS directive. For MPS green status, please visit the MPS website under Quality Assurance. "MPS" and "The Future of Analog IC Technology" are registered trademarks of Monolithic Power Systems, Inc.

## TYPICAL APPLICATION

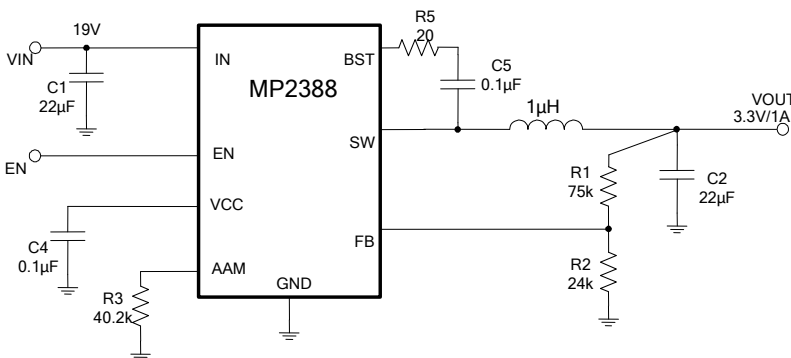

### Efficiency vs. Output Current

$V_{OUT}=3.3V$ ,  $L=1\mu H$ ,  $I_{OUT}=0.01A$  to  $1A$   
 $R_{AAM}=40.2k$  @  $V_{IN}=12V$  to  $21V$ ,  
 $R_{AAM}=80.6k$  @  $V_{IN}=5V$

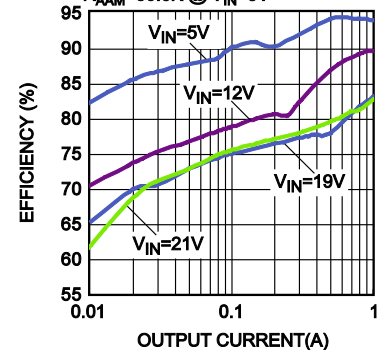

### ORDERING INFORMATION

Part Number*	Package	Top Marking
MP2388GQEU	QFN-8 (1.5mmx2.5mm)	See Below

For Tape & Reel, add suffix -Z (e.g. MP2388GQEU-Z)

### TOP MARKING

—  
**EL**  
**YW**  
**LL**

EL: Product code of MP2388GQEU  
 Y: Year code  
 W: Week code  
 LL: Lot number

### PACKAGE REFERENCE

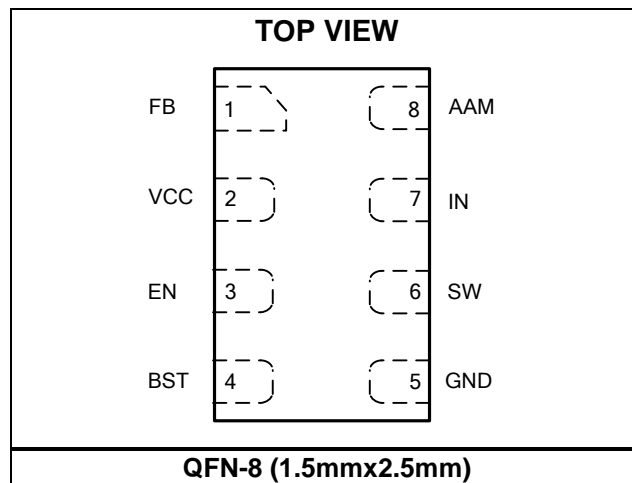

**ABSOLUTE MAXIMUM RATINGS<sup>(1)</sup>**

$V_{IN}$ .....	-0.3V to +28V
$V_{SW}$ ....	-0.3V (-5V < 10ns) to +28V (30V < 10ns)
$V_{BST}$ .....	$V_{SW} + 6V$
All other pins <sup>(2)</sup> .....	-0.3V to +6V
Continuous power dissipation ( $T_A = +25^\circ C$ ) <sup>(3)</sup>	1.25W
Junction temperature .....	150°C
Lead temperature .....	260°C
Storage temperature.....	-65°C to 150°C

**Recommended Operating Conditions<sup>(4)</sup>**

Supply voltage ( $V_{IN}$ ) .....	4.5 to 21V
Output voltage ( $V_{OUT}$ ).....	0.8V to $V_{IN} * D_{MAX}$
Operating junction temp ( $T_J$ ). ...	-40°C to +125°C

<b>Thermal Resistance<sup>(5)</sup></b>	$\theta_{JA}$	$\theta_{JC}$
QFN-8 (1.5mmx2.5mm).....	100.....	20.....°C/W

**NOTES:**

- 1) Exceeding these ratings may damage the device.
- 2) For details of EN's ABS MAX rating, please refer to the EN control section on page 11.
- 3) The maximum allowable power dissipation is a function of the maximum junction temperature  $T_J$  (MAX), the junction-to-ambient thermal resistance  $\theta_{JA}$ , and the ambient temperature  $T_A$ . The maximum allowable continuous power dissipation at any ambient temperature is calculated by  $P_D$  (MAX) =  $(T_J$  (MAX) -  $T_A$ ) /  $\theta_{JA}$ . Exceeding the maximum allowable power dissipation produces an excessive die temperature, causing the regulator to go into thermal shutdown. Internal thermal shutdown circuitry protects the device from permanent damage.
- 4) The device is not guaranteed to function outside of its operating conditions.
- 5) Measured on JESD51-7, 4-layer PCB.

## ELECTRICAL CHARACTERISTICS

$V_{IN} = 12V$ ,  $T_A = 25^\circ C$ , unless otherwise noted.

Parameter	Symbol	Condition	Min	Typ	Max	Units
Supply current (shutdown)	$I_{IN}$	$V_{EN} = 0V$			1	$\mu A$
Supply current (quiescent)	$I_q$	$V_{EN} = 2V$ , $V_{FB} = 1V$ , $AAM = 0.5V$		0.2		mA
		$V_{EN} = 2V$ , $V_{FB} = 1V$ , $AAM = 5V$		0.7		
HS switch on resistance	$HS_{RDS-ON}$	$V_{BST-SW} = 5V$		110		m $\Omega$
LS switch on resistance	$LS_{RDS-ON}$	$V_{CC} = 5V$		50		m $\Omega$
Switch leakage	$SW_{LKG}$	$V_{EN} = 0V$ , $V_{SW} = 12V$			1	$\mu A$
Current limit	$I_{LIMIT}$	Duty cycle = 40%	2.4	3		A
Oscillator frequency	$f_{SW}$	$V_{FB} = 750mV$	1700	2000	2400	kHz
Foldback frequency	$f_{FB}$	$V_{FB} < 400mV$		0.3		$f_{SW}$
Maximum duty cycle	$D_{MAX}$	$V_{FB} = 700mV$	78	83		%
Minimum on time <sup>(6)</sup>	$T_{ON\ MIN}$			35		ns
Feedback voltage	$V_{FB}$	$T_A = 25^\circ C$	786	798	810	mV
Feedback current	$I_{FB}$	$V_{FB} = 820mV$		10	50	nA
EN rising threshold	$V_{EN\ RISING}$		1.2	1.4	1.6	V
EN hysteresis	$V_{EN\ HYS}$		80	150	220	mV
EN input current	$I_{EN}$	$V_{EN} = 2V$		2		$\mu A$
		$V_{EN} = 0$		0		nA
VIN under-voltage lockout threshold rising	$INUV_{Vth}$		3.7	3.9	4.1	V
VIN under-voltage lockout threshold hysteresis	$INUV_{HYS}$			620		mV
VCC regulator	$V_{CC}$			4.9		V
VCC load regulation		$I_{CC} = 5mA$		1.5		%
Soft-start period	$T_{SS}$	$V_{OUT}$ from 10% to 90%	0.8	1.5	2.2	ms
Thermal shutdown <sup>(6)</sup>				150		$^\circ C$
Thermal hysteresis <sup>(6)</sup>				20		$^\circ C$
AAM source current	$I_{AAM}$		5.6	6.2	6.8	$\mu A$

**NOTE:**

6) Guaranteed by design

## TYPICAL PERFORMANCE CHARACTERISTICS

$V_{IN} = 19V$ ,  $V_{OUT} = 3.3V$ ,  $L = 1\mu H$ ,  $T_A = 25^\circ C$ , unless otherwise noted.

### Case Temperature Rise vs. Output Current

$V_{OUT} = 3.3V$ ,  $I_{OUT} = 0.5A$  to  $1A$ ,  
2 Layers PCB

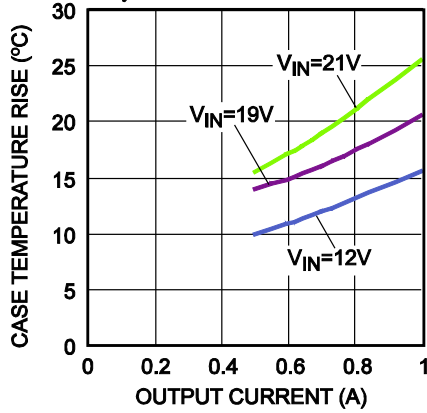

### Load Regulation

$V_{IN} = 5V$  to  $21V$ ,  $I_{OUT} = 0.1A$  to  $1A$

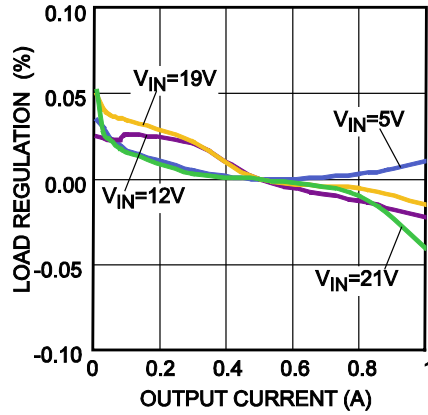

### Line Regulation

$V_{IN} = 5V$  to  $21V$ ,  $I_{OUT} = 0A$  to  $1A$

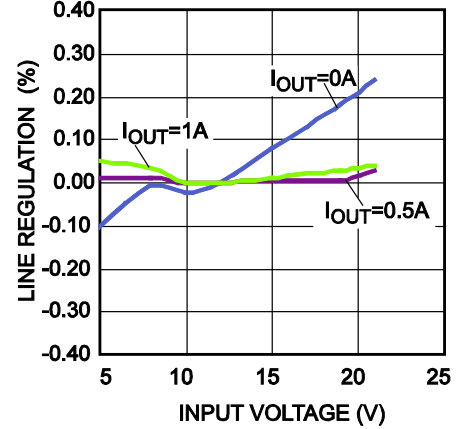

### Peak Current Limit vs. Duty Cycle

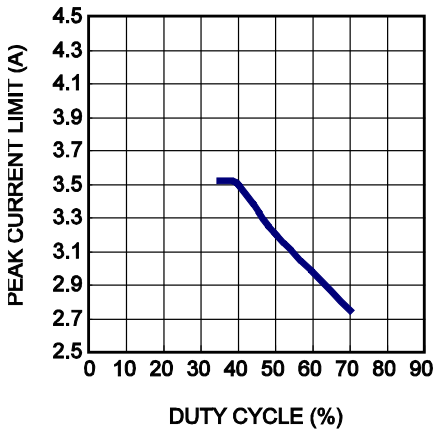

### Feedback Voltage vs. Temperature

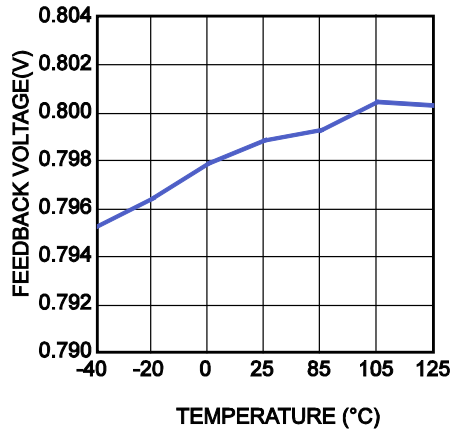

### Enabled Supply Current vs. Input Voltage

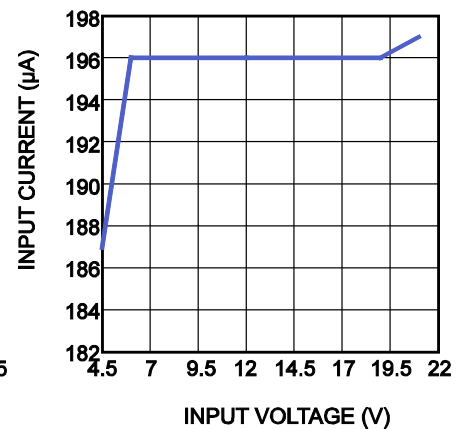

**TYPICAL PERFORMANCE CHARACTERISTICS** *(continued)*
 $V_{IN} = 19V$ ,  $V_{OUT} = 3.3V$ ,  $L = 1\mu H$ ,  $T_A = 25^\circ C$ , unless otherwise noted.

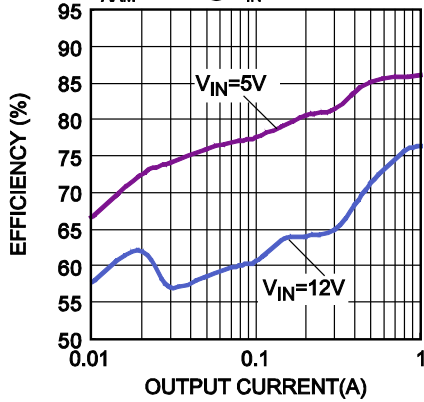
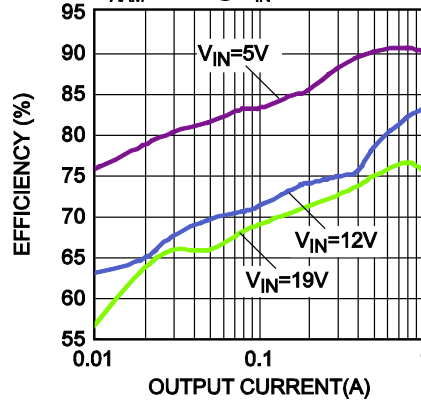
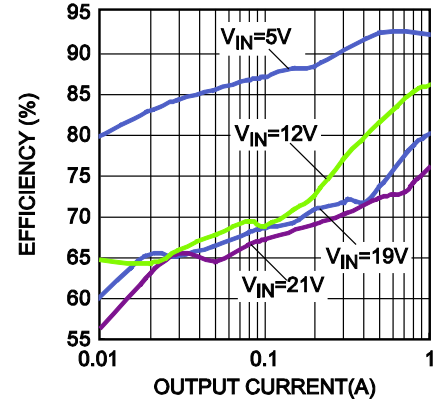
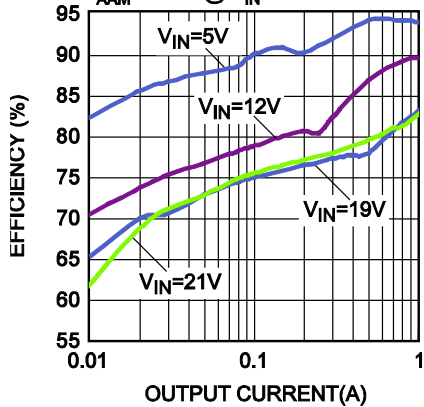
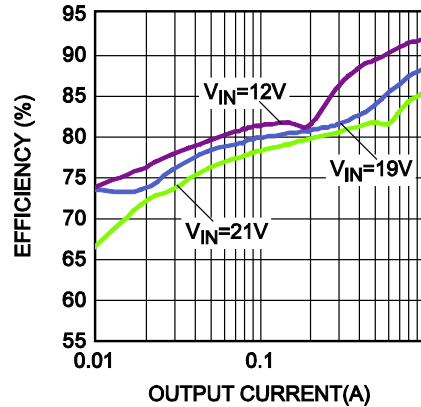
**Efficiency vs. Output Current**
 $V_{OUT}=1.2V$ ,  $L=0.68\mu H$ ,  $I_{OUT}=0.01A$  to  $1A$   
 $R_{AAM}=19.1k$  @  $V_{IN}=12V$ ,  
 $R_{AAM}=41.2k$  @  $V_{IN}=5V$ 

**Efficiency vs. Output Current**
 $V_{OUT}=1.8V$ ,  $L=0.82\mu H$ ,  $I_{OUT}=0.01A$  to  $1A$   
 $R_{AAM}=32.4k$  @  $V_{IN}=12V$  to  $19V$   
 $R_{AAM}=51.1k$  @  $V_{IN}=5V$ 

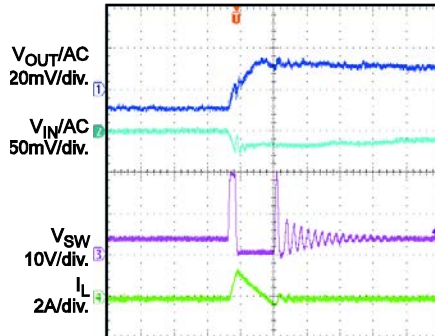
**Efficiency vs. Output Current**
 $V_{OUT}=2.5V$ ,  $L=0.82\mu H$ ,  $I_{OUT}=0.01A$  to  $1A$   
 $R_{AAM}=28.7k$  @  $V_{IN}=12V$  to  $21V$ ,  
 $R_{AAM}=63.4k$  @  $V_{IN}=5V$ 

**Efficiency vs. Output Current**
 $V_{OUT}=3.3V$ ,  $L=1\mu H$ ,  $I_{OUT}=0.01A$  to  $1A$   
 $R_{AAM}=40.2k$  @  $V_{IN}=12V$  to  $21V$ ,  
 $R_{AAM}=80.6k$  @  $V_{IN}=5V$ 

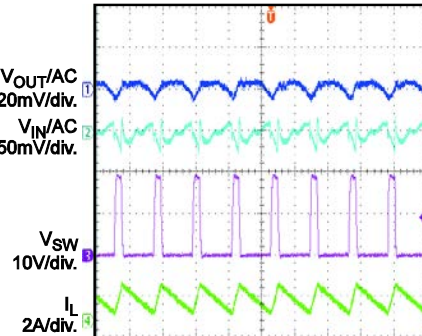
**Efficiency vs. Output Current**
 $V_{OUT}=5V$ ,  $L=1.5\mu H$ ,  $I_{OUT}=0.01A$  to  $1A$   
 $R_{AAM}=54.9k$  @  $V_{IN}=12V$  to  $21V$ 

**TYPICAL PERFORMANCE CHARACTERISTICS** *(continued)*
 $V_{IN} = 19V$ ,  $V_{OUT} = 3.3V$ ,  $L = 1\mu H$ ,  $T_A = 25^\circ C$ , unless otherwise noted.

**Input/Output Ripple**
 $I_{OUT} = 0A$ 

400ns/div.

**Input/Output Ripple**
 $I_{OUT} = 1A$ 

400ns/div.

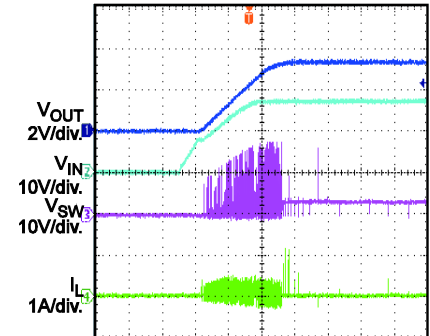
**Start-Up through Input Voltage**
 $I_{OUT} = 0A$ 

1ms/div.

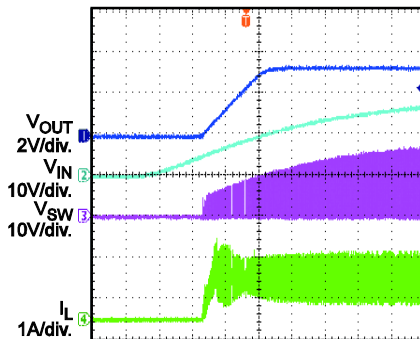
**Start-Up through Input Voltage**
 $I_{OUT} = 1A$ 

1ms/div.

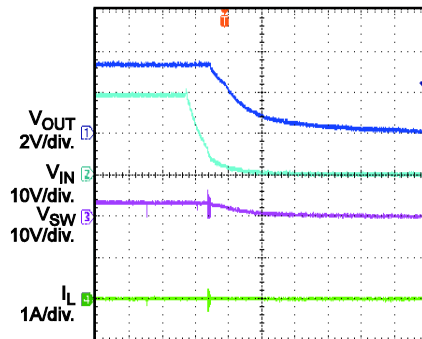
**Shutdown through Input Voltage**
 $I_{OUT} = 0A$ 

400ms/div.

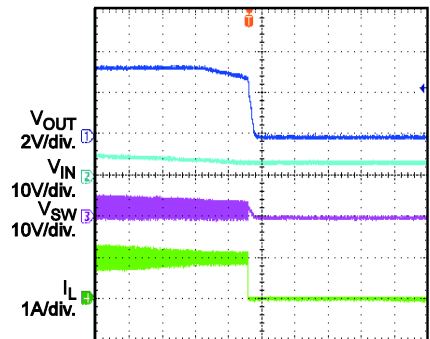
**Shutdown through Input Voltage**
 $I_{OUT} = 1A$ 

400µs/div.

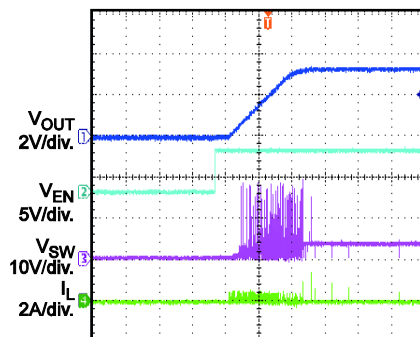
**Start-Up through Enable**
 $I_{OUT} = 0A$ 

1ms/div.

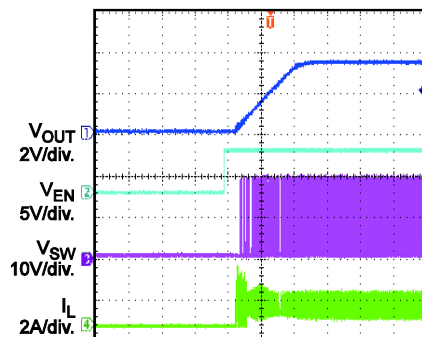
**Start-Up through Enable**
 $I_{OUT} = 1A$ 

1ms/div.

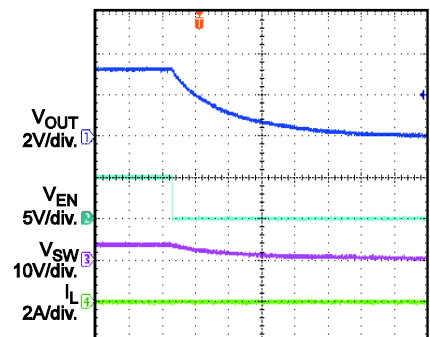
**Shutdown through Enable**
 $I_{OUT} = 0A$ 

400ms/div.

**TYPICAL PERFORMANCE CHARACTERISTICS** *(continued)*
 $V_{IN} = 19V$ ,  $V_{OUT} = 3.3V$ ,  $L = 1\mu H$ ,  $T_A = 25^\circ C$ , unless otherwise noted.

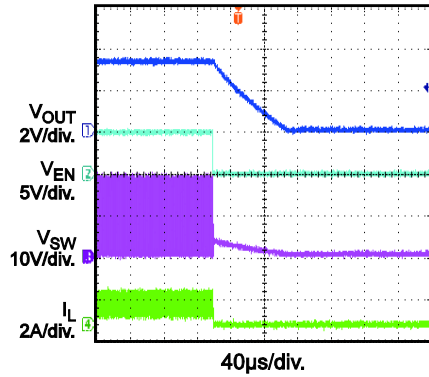
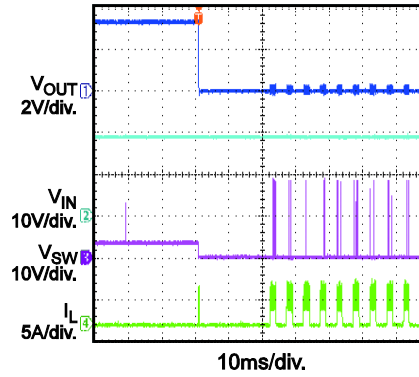
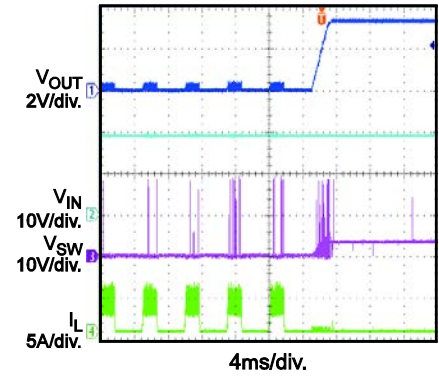
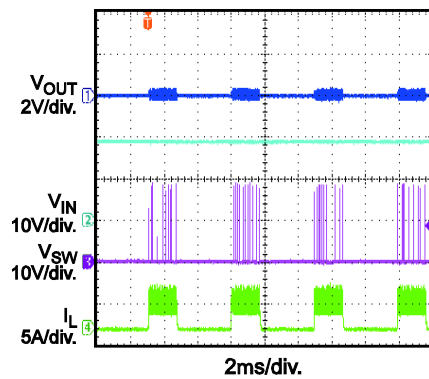
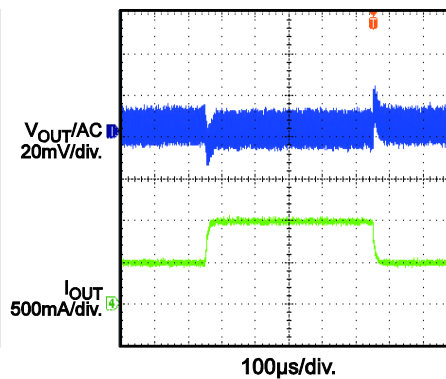
**Shutdown through Enable**
 $I_{OUT} = 1A$ 

**Short-Circuit Entry**
 $I_{OUT} = 0A$ 

**Short-Circuit Recovery**
 $I_{OUT} = 0A$ 

**Short-Circuit Steady**
 $I_{OUT} = 0A$ 

**Load Transient**
 $I_{OUT} = 0.5A$  to  $1A$ ,  $2.5A/\mu s$ 

## PIN FUNCTIONS

Package Pin #	Name	Description
1	FB	<b>Feedback.</b> An external resistor divider from the output to GND tapped to FB sets the output voltage. To prevent current limit runaway during a short-circuit fault condition, the frequency foldback comparator lowers the oscillator frequency when the FB voltage is below 400mV.
2	VCC	<b>Bias supply.</b> Decouple VCC with a 0.1 $\mu$ F - 0.22 $\mu$ F capacitor. The capacitance should be no more than 0.22 $\mu$ F.
3	EN	<b>Enable.</b> Set EN to 1 to enable the MP2388.
4	BST	<b>Bootstrap.</b> A capacitor and a 20 $\Omega$ resistor connected between SW and BST are required to form a floating supply across the high-side switch driver.
5	GND	<b>System ground.</b> GND is the reference ground of the regulated output voltage and requires careful consideration during PCB layout. Connect GND with coppers and vias.
6	SW	<b>Switch output.</b> Use wide PCB traces to make the connection.
7	IN	<b>Supply voltage.</b> The MP2388 operates on a 4.5V-to-21V input rail. C1 is needed to decouple the input rail. Use wide PCB traces to make the connection.
8	AAM	<b>Advanced asynchronous modulation.</b> A resistor connected from AAM to ground sets an AAM voltage to force the MP2388 into non-synchronous mode when the load is small. Drive AAM high when connected to VCC or float AAM to force the MP2388 into continuous conduction mode (CCM).

**BLOCK DIAGRAM**

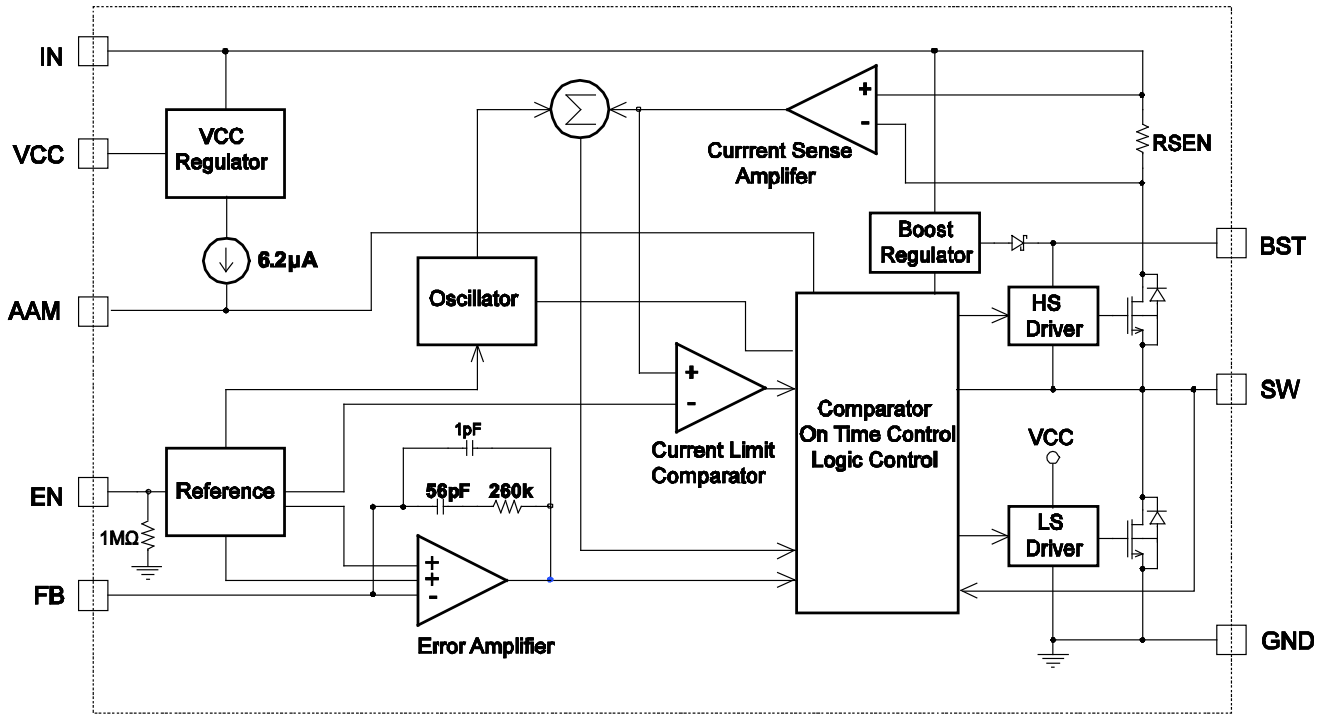

Figure 1: Functional Block Diagram



### Internal Soft Start (SS)

A soft start (SS) is implemented to prevent the converter output voltage from overshooting during start-up. When the chip starts up, the internal circuitry generates a soft-start voltage that ramps up from 0V. The soft-start period lasts until the voltage on the soft-start capacitor exceeds the reference voltage (0.798V). At this point, the reference voltage takes over. The soft-start time is internally set to around 1.5ms.

### Over-Current Protection (OCP) and Hiccup

The MP2388 uses a cycle-by-cycle over-current limit when the inductor current peak value exceeds the set current-limit threshold. Meanwhile, the output voltage drops until FB is below the under-voltage (UV) threshold, typically 50% below the reference. Once UV is triggered, the MP2388 enters hiccup mode to restart the part periodically. This protection mode is especially useful when the output is dead-shortened to ground. The average short-circuit current is greatly reduced to alleviate thermal issues and protect the regulator. The MP2388 exits hiccup mode once the over-current condition is removed.

### Thermal Shutdown

Thermal shutdown is implemented to prevent the chip from operating at exceedingly high temperatures. When the silicon die temperature is higher than 150°C, the entire chip shuts down. When the temperature is below its lower threshold (typically 130°C), the chip is enabled again.

### Floating Driver and Bootstrap Charging

The floating power MOSFET driver is powered by an external bootstrap capacitor. This floating driver has its own UVLO protection. The UVLO rising threshold is 2.2V with a hysteresis of 150mV. The bootstrap capacitor voltage is regulated internally by  $V_{IN}$  through D1, R5, C5, L1, and C2 (see Figure 4). If  $V_{IN} - V_{SW}$  is more than 5V, U1 regulates M1 to maintain a 5V BST voltage across C5.

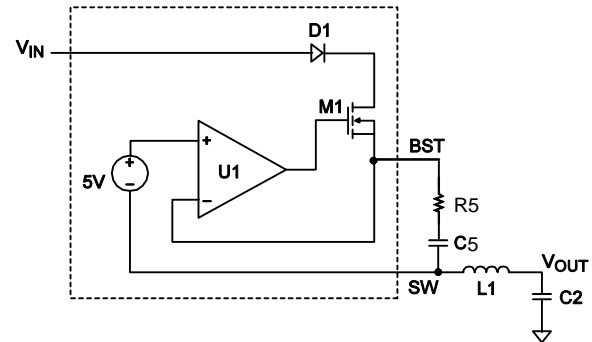

**Figure 4: Internal Bootstrap Charging Circuit**

### Start-Up and Shutdown

If both  $V_{IN}$  and EN are higher than their appropriate thresholds, the chip starts. The reference block starts first, generating a stable reference voltage and current, and then the internal regulator is enabled. The regulator provides a stable supply for the remaining circuitries.

Three events can shut down the chip: EN low,  $V_{IN}$  low, and thermal shutdown. In the shutdown procedure, the signaling path is first blocked to prevent any fault triggering.  $V_{COMP}$  and the internal supply rail are then pulled down. The floating driver is not subject to this shutdown command.

## APPLICATION INFORMATION

### Setting the Output Voltage

The external resistor divider is used to set the output voltage (see Typical Application on page 1). The feedback resistor R1 also sets the feedback loop bandwidth with the internal compensation capacitor (see the Typical Application on page 1). R2 can then be calculated with Equation (1):

$$R2 = \frac{R1}{\frac{V_{OUT}}{0.798V} - 1} \quad (1)$$

The feedback network is shown in Figure 5.

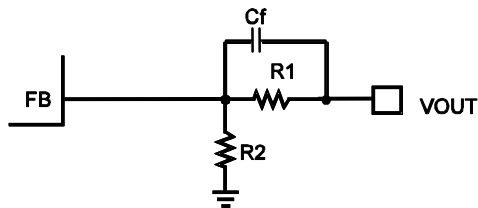

**Figure 5: Feedback Network**

Table 1 lists the recommended feedback resistor values for common output voltages.

**Table 1: Resistor Selection for Common Output Voltages**

V <sub>OUT</sub> (V)	R1 (kΩ)	R2 (kΩ)
1.05	191	604
1.2	191	383
1.8	102	82
2.5	102	47.5
3.3	75	24
5	100	19.1

### Selecting the Inductor

A 0.47μH-to-4.7μH inductor with a DC current rating at least 25% percent higher than the maximum load current is recommended for most applications. For the highest efficiency, the inductor DC resistance should be less than 15mΩ. For most designs, the inductance value can be derived from Equation (2):

$$L_1 = \frac{V_{OUT} \times (V_{IN} - V_{OUT})}{V_{IN} \times \Delta I_L \times f_{OSC}} \quad (2)$$

Where ΔI<sub>L</sub> is the inductor ripple current.

Choose the inductor current to be approximately 30% of the maximum load current. The maximum inductor peak current can be calculated with Equation (3):

$$I_{L(MAX)} = I_{LOAD} + \frac{\Delta I_L}{2} \quad (3)$$

Under light-load conditions below 100mA, a larger inductance is recommended for improved efficiency.

### Setting the AAM Voltage

The AAM voltage is used to set the transition point from AAM to PWM. It should be chosen to provide the best combination of efficiency, stability, ripple, and transient.

If the AAM voltage is set lower, then stability and ripple improve, but efficiency during AAM mode and transient degrade. Likewise, if the AAM voltage is set higher, then the efficiency during AAM and transient improve, but stability and ripple degrade.

Adjust the AAM threshold by connecting a resistor from AAM to ground (see Figure 6). An internal 6.2μA current source charges the external resistor.

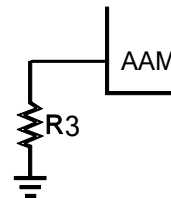
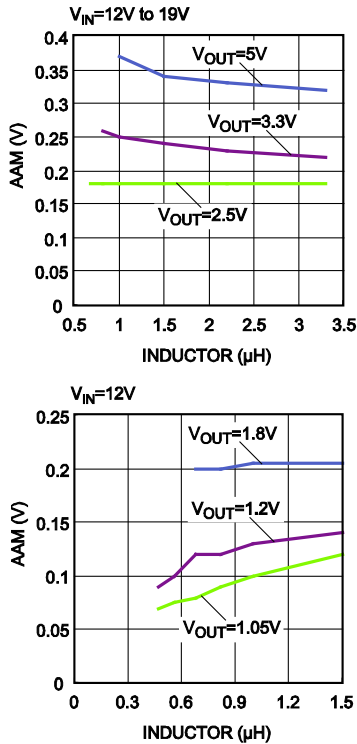

**Figure 6: AAM Network**

Generally, R3 is can be calculated with Equation (4):

$$V_{AAM} = R3 \times 6.2 \mu A \quad (4)$$

The optimized AAM is shown in Figure 7.



**Figure 7: AAM Selection for Common Output Voltages**

### Selecting the Input Capacitor

The input current to the step-down converter is discontinuous, and therefore requires a capacitor to supply AC current to the step-down converter while maintaining the DC input voltage. Use low ESR capacitors for best performance. Ceramic capacitors with X5R or X7R dielectrics are highly recommended because of their low ESR and small temperature coefficients. For most applications, a 22μF capacitor is sufficient.

Since the input capacitor (C1) absorbs the input switching current, it requires an adequate ripple current rating. The RMS current in the input capacitor can be estimated with Equation (5):

$$I_{C1} = I_{LOAD} \times \sqrt{\frac{V_{OUT}}{V_{IN}} \times \left(1 - \frac{V_{OUT}}{V_{IN}}\right)} \quad (5)$$

The worst-case condition occurs at  $V_{IN} = 2V_{OUT}$ , shown in Equation (6):

$$I_{C1} = \frac{I_{LOAD}}{2} \quad (6)$$

For simplification, choose an input capacitor with an RMS current rating greater than half of the maximum load current.

The input capacitor can be electrolytic, tantalum, or ceramic. When using electrolytic or tantalum capacitors, a small, high-quality ceramic capacitor (i.e.: 0.1μF) should be placed as close to the IC as possible. When using ceramic capacitors, ensure that they have enough capacitance to provide a sufficient charge to prevent excessive voltage ripple at input. The input voltage ripple caused by capacitance can be estimated with Equation (7):

$$\Delta V_{IN} = \frac{I_{LOAD}}{f_s \times C1} \times \frac{V_{OUT}}{V_{IN}} \times \left(1 - \frac{V_{OUT}}{V_{IN}}\right) \quad (7)$$

### Selecting the Output Capacitor

The output capacitor (C2) is required to maintain the DC output voltage. Ceramic, tantalum, or low ESR electrolytic capacitors are recommended. Use low ESR capacitors to keep the output voltage ripple low. The output voltage ripple can be estimated with Equation (8):

$$\Delta V_{OUT} = \frac{V_{OUT}}{f_s \times L_1} \times \left(1 - \frac{V_{OUT}}{V_{IN}}\right) \times \left(R_{ESR} + \frac{1}{8 \times f_s \times C2}\right) \quad (8)$$

Where  $L_1$  is the inductor value and  $R_{ESR}$  is the equivalent series resistance (ESR) value of the output capacitor.

In the case of ceramic capacitors, the impedance at the switching frequency is dominated by the capacitance. The output voltage ripple is mainly caused by the capacitance. For simplification, the output voltage ripple can be estimated with Equation (9):

$$\Delta V_{OUT} = \frac{V_{OUT}}{8 \times f_s^2 \times L_1 \times C2} \times \left(1 - \frac{V_{OUT}}{V_{IN}}\right) \quad (9)$$

In the case of tantalum or electrolytic capacitors, the ESR dominates the impedance at the switching frequency. For simplification, the output ripple can be approximated with Equation (10):

$$\Delta V_{OUT} = \frac{V_{OUT}}{f_s \times L_1} \times \left(1 - \frac{V_{OUT}}{V_{IN}}\right) \times R_{ESR} \quad (10)$$

The characteristics of the output capacitor also affect the stability of the regulation system. The MP2388 can be optimized for a wide range of capacitance and ESR values.

### External Bootstrap Diode

An external bootstrap diode may enhance the efficiency of the regulator. The applicable conditions of the external BST diode are:

- $V_{OUT}$  is 5V or 3.3V
- Duty cycle is high:  $D = \frac{V_{OUT}}{V_{IN}} > 65\%$

In these cases, an external BST diode is recommended from VCC to BST (see Figure 8).

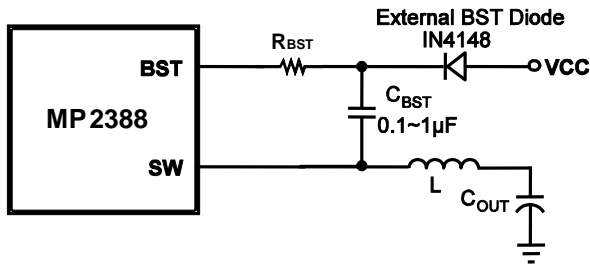

**Figure 8: Optional External Bootstrap Diode Added to Enhance Efficiency**

The recommended external BST diode is IN4148, and the recommended BST cap is 0.1 - 1µF.

### PCB Layout Guidelines<sup>(7)</sup>

Efficient PCB layout is critical for stable operation. For best results, refer to Figure 9 and follow the guidelines below.

1. Keep the connection of the input ground and GND as short and wide as possible.
2. Keep the connection of the input capacitor and IN as short and wide as possible.
3. Ensure that all feedback connections are short and direct.
4. Place the feedback resistors and compensation components as close to the chip as possible.
5. Route SW away from sensitive analog areas, such as FB.

**NOTE:**

7) The recommended layout is based on the Typical Application Circuit on page 16.

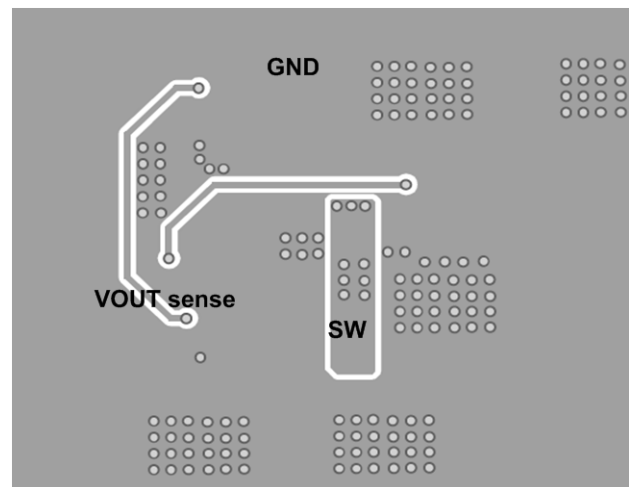
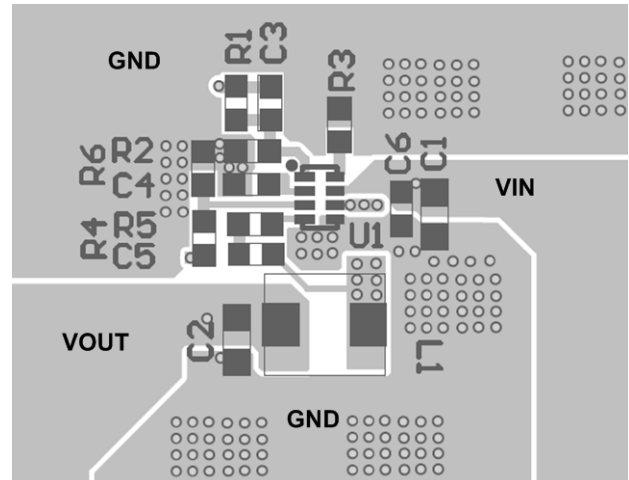

**Figure 9: Sample Board Layout**

### Design Example

Table 2 is a design example following the application guidelines for the specifications below:

**Table 2: Design Example**

$V_{IN}$	19V
$V_{OUT}$	3.3V
$I_O$	1A

The detailed application schematics are shown in Figure 10 through Figure 15. The typical performance and circuit waveforms are shown in the Typical Performance Characteristics section. For more device applications, please refer to the related evaluation board datasheets.

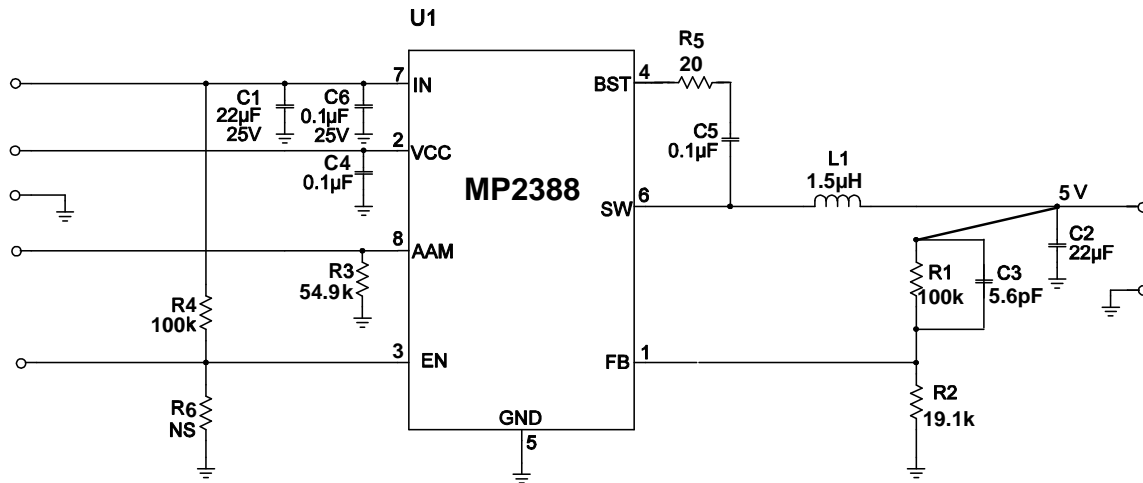
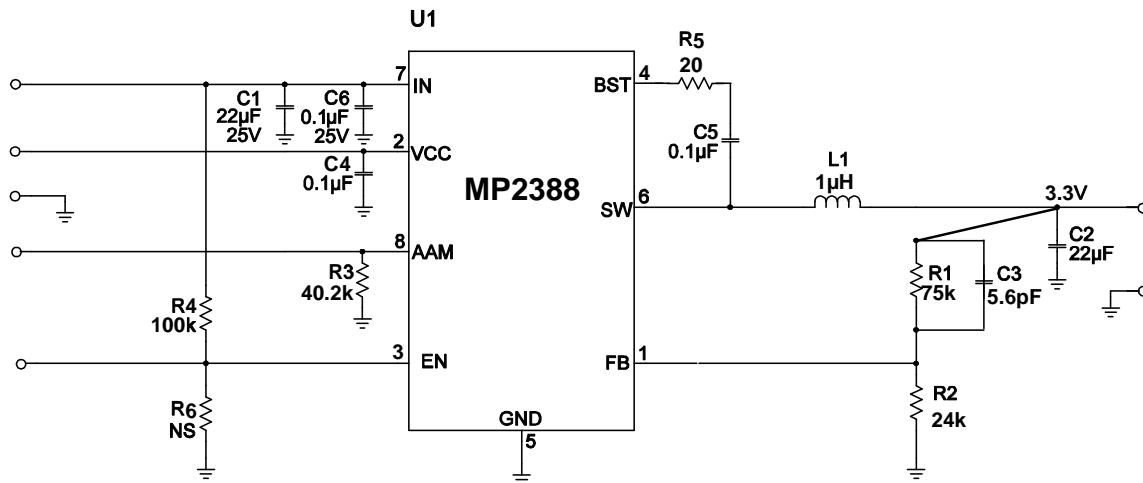
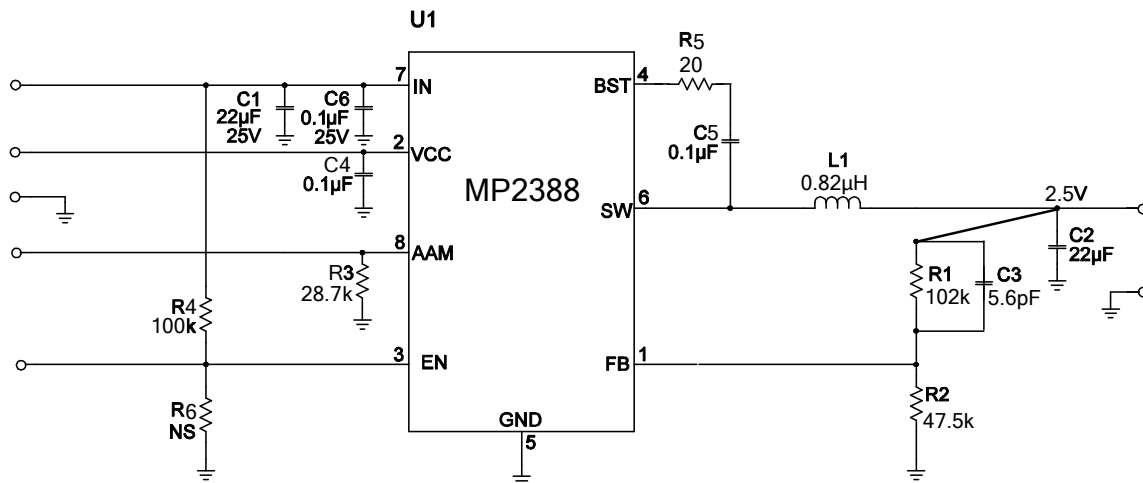
**TYPICAL APPLICATION CIRCUITS <sup>(8)</sup>**

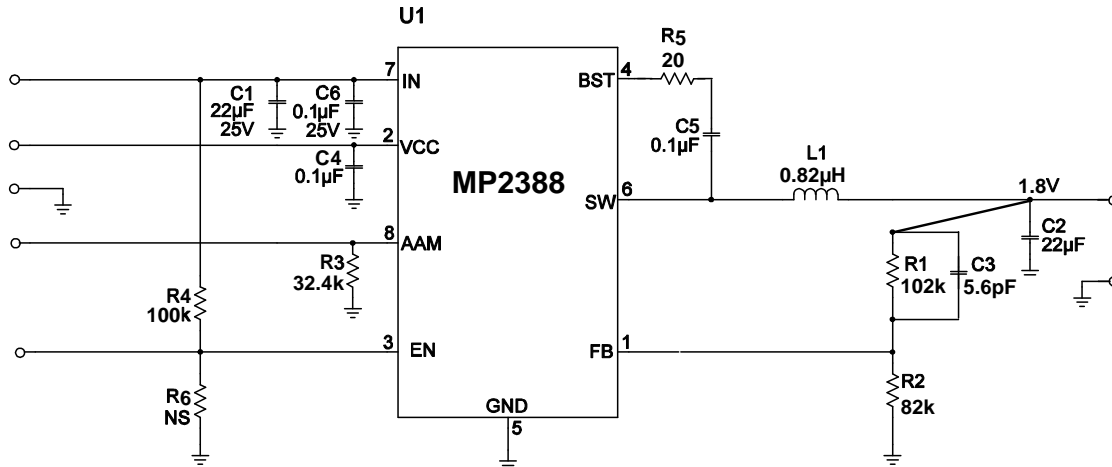
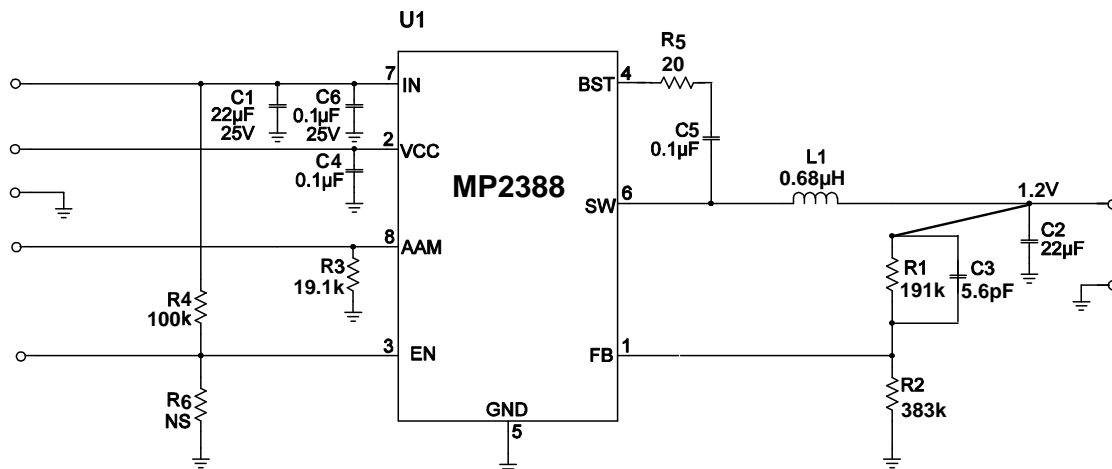
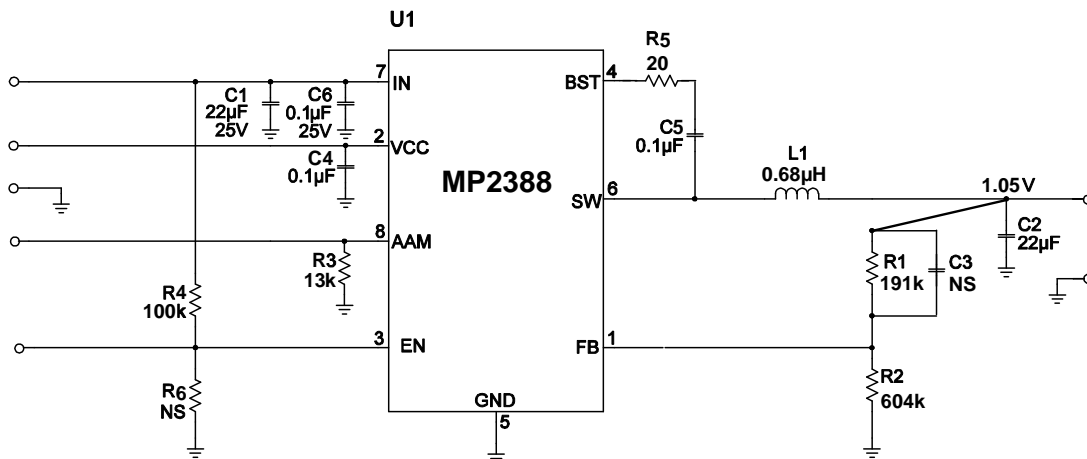
**Figure 10:  $V_{IN} = 19V$ ,  $V_o = 5V$ ,  $I_o = 1A$** 

**Figure 11:  $V_{IN} = 19V$ ,  $V_o = 3.3V$ ,  $I_o = 1A$** 

**Figure 12:  $V_{IN} = 19V$ ,  $V_o = 2.5V$ ,  $I_o = 1A$** 
**TYPICAL APPLICATION CIRCUITS (continued)**

**Figure 13:  $V_{IN} = 12V$ ,  $V_o = 1.8V$ ,  $I_o = 1A$** 

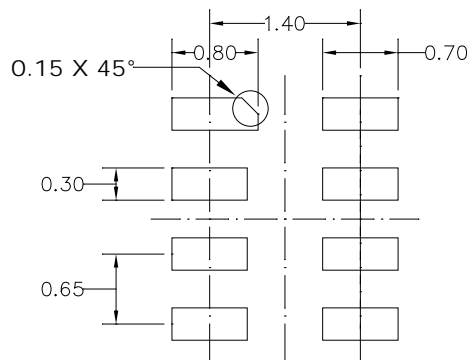
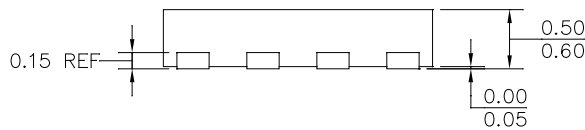
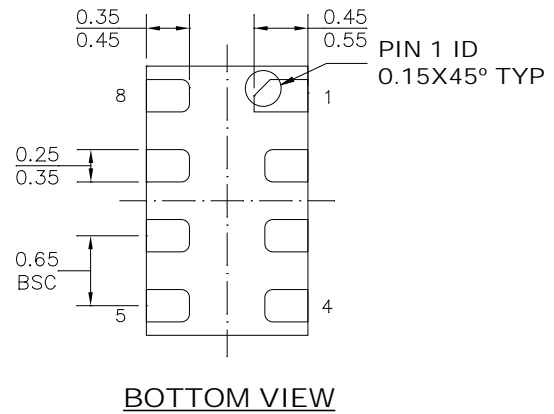
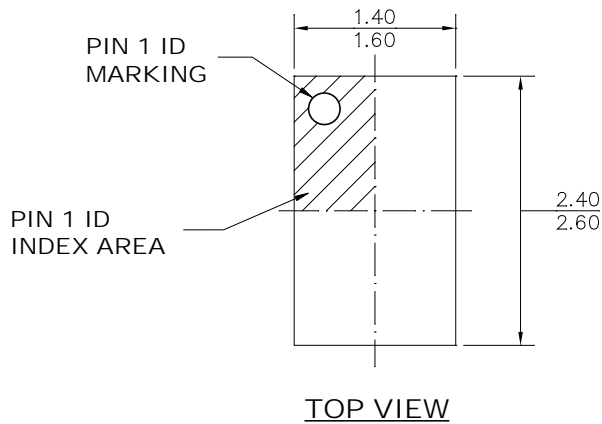
**Figure 14:  $V_{IN} = 12V$ ,  $V_o = 1.2V$ ,  $I_o = 1A$** 

**Figure 15:  $V_{IN} = 12V$ ,  $V_o = 1.05V$ ,  $I_o = 1A$** 
**NOTE:**

8) In  $12V_{IN}$  to  $1.05V_{OUT}$  applications, the HS-FET's on time is close to the minimum on time. Although the SW may have a little jitter, the output voltage ripple is smaller than 15mV in PWM mode.

## PACKAGE INFORMATION

### QFN-8 (1.5mmx2.5mm)



#### NOTE:

- 1) ALL DIMENSIONS ARE IN MILLIMETERS.
- 2) LEAD COPLANARITY SHALL BE 0.10 MILLIMETERS MAX.
- 3) JEDEC REFERENCE IS MO-220.
- 4) DRAWING IS NOT TO SCALE.

**NOTICE:** The information in this document is subject to change without notice. Users should warrant and guarantee that third party Intellectual Property rights are not infringed upon when integrating MPS products into any application. MPS will not assume any legal responsibility for any said applications.

## Looking for pricing, stock, or lifecycle information?

Click below to explore more details on WIN SOURCE:

- ⊖ [View MP2388GQEU-Z on WIN SOURCE](#)
- ⊖ [Monolithic Power Systems Inc. Information](#)

## Optimize Your Supply Chain with WIN SOURCE Solutions

- ✓ Global Sourcing Solution
- ✓ Obsolete Management
- ✓ Cost Control Management
- ✓ Shortage Management
- ✓ Alternative Solution
- ✓ Excess Inventory Management