



**THE DATASHEET OF
NB3N501DG**



NB3N501

3.3V / 5.0V 13 MHz to 160 MHz PLL Clock Multiplier



ON Semiconductor®

<http://onsemi.com>

Description

The NB3N501 is a clock multiplier that will generate one of nine selectable output multiples of an input frequency via two 3-level select inputs (S0, S1). It accepts a standard fundamental mode crystal or an external reference clock signal. Phase-Locked-Loop (PLL) design techniques are used to produce a low jitter, TTL level clock output up to 160 MHz with a 50% duty cycle. An Output Enable (OE) pin is provided, and when asserted low, the clock output goes into tri-state (high impedance). The NB3N501 is commonly used in electronic systems as a cost efficient replacement for crystal oscillators

Features

- Clock Output Frequencies up to 160 MHz
- Nine Selectable Multipliers of the Input Frequency
- Operating Range: $V_{DD} = 3.3\text{ V} \pm 10\%$ or $5.0\text{ V} \pm 5\%$
- Low Jitter Output of 25 ps One Sigma (rms)
- Zero ppm Clock Multiplication Error
- 45% – 55% Output Duty Cycle
- TTL/CMOS Output with 25 mA TTL Level Drive
- Crystal Reference Input Range of 5 – 27 MHz
- Input Clock Frequency Range of 2 – 50 MHz
- OE, Output Enable with Tri-State Output
- 8-Pin SOIC
- Industrial Temperature Range -40°C to $+85^{\circ}\text{C}$
- These are Pb-Free Devices

MARKING DIAGRAM

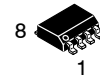

SOIC-8
D SUFFIX
CASE 751

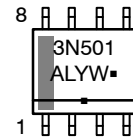

3N501 = Specific Device Code
A = Assembly Location
L = Wafer Lot
Y = Year
W = Work Week
▪ = Pb-Free Package

ORDERING INFORMATION

See detailed ordering and shipping information in the package dimensions section on page 5 of this data sheet.

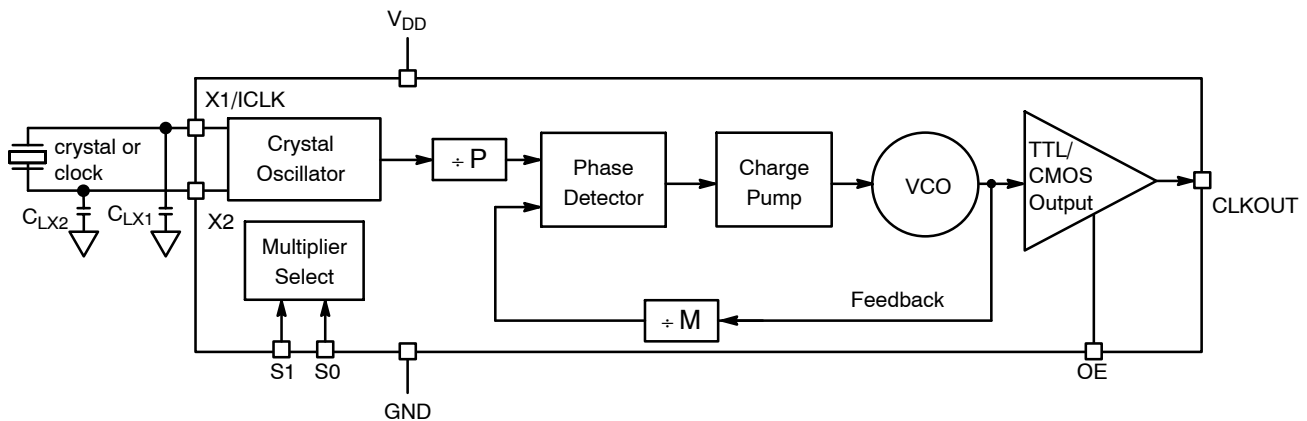

Figure 1. NB3N501 Logic Diagram

NB3N501

Table 1. CLOCK MULTIPLIER SELECT TABLE

S1*	S0*	CLKOUT Multiplier
L	L	4X Input
L	M	5.3125X Input
L	H	5X Input
M	L	6.25X Input
M	M	2X Input
M	H	3.125X Input
H	L	6X Input
H	M	3X Input
H	H	8X Input

*Pins S1 and S0 default to M when open
 L = GND
 H = VDD
 M = OPEN (unconnected; will default to VDD/2)

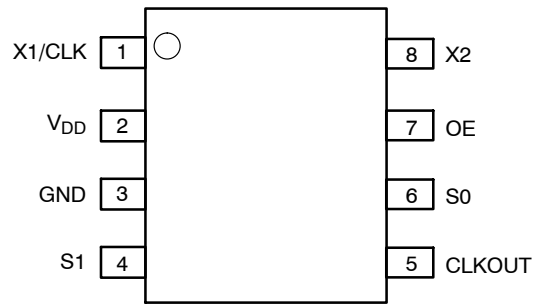

Figure 2. NB3N501 Package Pinout, 8-Pin (150 mil) SOIC

Table 2. PIN DESCRIPTION

Pin #	Name	I/O	Description
1	X1/CLK	Input	Crystal or external reference clock input
2	VDD	Power supply	Positive supply voltage
3	GND	Power supply	0 V. Ground.
4	S1	Three level Input	Multiplier select pin – connect to V _{DD} , GND or float
5	CLKOUT	CMOS/TTL Output	Clock output
6	S0	Three level Input	Multiplier select pin – connect to V _{DD} , GND or float
7	OE	CMOS/TTL Input	Output Enable. CLKOUT is high impedance when OE is low. Internal pullup
8	X2	Crystal	Crystal input – Leave open when providing an external clock reference

Table 3. COMMON OUTPUT FREQUENCY EXAMPLES

Output Frequency (MHz)	Input Frequency (MHz)	S1, S0
20	10	M, M
24	12	M, M
30	10	1, M
32	16	M, M
33.33	16.66	M, M
37.5	12	M, 1
40	10	0, 0
48	12	0, 0
50	16.66	1, M
60	10	1, 0
62.5	20	M, 1

Table 3. COMMON OUTPUT FREQUENCY EXAMPLES

Output Frequency (MHz)	Input Frequency (MHz)	S1, S0
64	16	0, 0
66.66	16.66	0, 0
72	12	1, 0
75	12	M, 0
80	10	1, 1
83.33	16.66	0, 1
90	15	1, 0
100	20	0, 1
106.25	20	0, M
120	15	1, 1
125	20	M, 0

NB3N501

Table 4. ATTRIBUTES

Characteristics		Value
ESD Protection	Human Body Model	> 1 kV
	Machine Model	> 150 V
	Charged Device Model	> 1 kV
Moisture Sensitivity (Note 1)	SOIC-8	Level 1
Flammability Rating	Oxygen Index: 28 to 34	UL 94 V 0 @ 0.125 in
Transistor Count		9727
Meets or exceeds JEDEC Spec EIA/JESD78 IC Latchup Test		

1. For additional information, see Application Note AND8003/D.

Table 5. MAXIMUM RATINGS

Symbol	Parameter	Condition 1	Condition 2	Rating	Unit
V _{DD}	Positive Power Supply	GND = 0 V		7	V
V _{IO}	Input and Output Voltages			$-0.5\text{ V} \leq V_{IO} \leq V_{DD} + 0.5$	V
T _A	Operating Temperature Range			-40 to +85	°C
T _{stg}	Storage Temperature Range			-65 to +150	°C
θ _{JA}	Thermal Resistance (Junction-to-Ambient)	0 lfpm 500 lfpm	SOIC-8 SOIC-8	190 130	°C/W
θ _{JC}	Thermal Resistance (Junction-to-Case)	(Note 2)	SOIC-8	41 to 44	°C/W
T _{sol}	Wave Solder Pb-Free			265	°C

Stresses exceeding Maximum Ratings may damage the device. Maximum Ratings are stress ratings only. Functional operation above the Recommended Operating Conditions is not implied. Extended exposure to stresses above the Recommended Operating Conditions may affect device reliability.

2. JEDEC standard multilayer board – 2S2P (2 signal, 2 power) with 8 filled thermal vias under exposed pad.

NB3N501

Table 6. DC CHARACTERISTICS $V_{DD} = 3.3\text{ V} \pm 10\%$ or $5.0\text{ V} \pm 5\%$ unless otherwise noted, $GND = 0\text{ V}$, $T_A = -40^\circ\text{C}$ to $+85^\circ\text{C}$

Symbol	Characteristic	Min	Typ	Max	Unit
V_{DD}	Operating Voltage at 100 MHz (with 20 MHz crystal) $V_{CC} = 5\text{ V}$ $V_{CC} = 3.3\text{ V}$	4.75 3.0		5.25 3.6	V
I_{DD}	Power Supply Current – Inputs and outputs open, CLKOUT operating at 100 MHz (with 20 MHz crystal) $V_{CC} = 5\text{ V}$ $V_{CC} = 3.3\text{ V}$		20 15		mA
V_{OH}	Output HIGH Voltage $I_{OH} = -4\text{ mA}$ CMOS High	$V_{DD} - 0.4$			V
V_{OH}	Output HIGH Voltage $I_{OH} = -25\text{ mA}$ TTL High	2.4			V
V_{OL}	Output LOW Voltage $I_{OL} = 25\text{ mA}$			0.4	V
V_{IH}	Input HIGH Voltage, CLK only (pin 1)	$(V_{DD} / 2) + 1$			V
V_{IL}	Input LOW Voltage, CLK only (pin 1)			$(V_{DD} / 2) - 1$	V
V_{IH}	Input HIGH Voltage, S0, S1	$V_{DD} - 0.5$			V
V_{IL}	Input LOW Voltage, S0, S1			0.5	V
V_{IH}	Input HIGH Voltage, OE (pin 7)	2.0			V
V_{IL}	Input LOW Voltage, OE (pin 7)			0.8	V
C_{in}	Input Capacitance, S0, S1 and OE		4		pF
I_{SC}	Output Short Circuit Current		± 70		mA
RPU	On Chip Pullup Resistor		270		$k\Omega$
	Nominal Output Impedance		20		Ω

3. The crystal should be fundamental mode, parallel resonant. Do not use third overtone. For exact tuning when using a crystal, capacitors should be connected from pins X1/CLK to GND and X2 to GND. The value of these capacitors is given by the following equation, where C_L is the specified crystal load capacitance: Crystal capacitance (pF) = $(C_L - 5) \times 2$. So, for a crystal with 16 pF load capacitance, use two 22 pF capacitors.

Table 7. AC CHARACTERISTICS $V_{DD} = 3.3\text{ V} \pm 10\%$ or $5.0\text{ V} \pm 5\%$ unless otherwise noted, $GND = 0\text{ V}$, $T_A = -40^\circ\text{C}$ to $+85^\circ\text{C}$

Symbol	Characteristic	Min	Typ	Max	Unit
f_{Xtal}	Crystal Input Frequency (Note 4)	5		27	MHz
f_{CLKIN}	Clock Input Frequency	2		50	MHz
f_{OUT}	Output Frequency Range $f_{OUTMIN} \leq f_{IN} \times \text{Multiplier} \leq f_{OUTMAX}$ $V_{DD} = 4.75\text{ to }5.25\text{ V (}5.0\text{ V} \pm 5\%)$ $V_{DD} = 3.0\text{ to }3.6\text{ V (}3.3\text{ V} \pm 10\%)$	13 13		160 100	MHz
DC	Output Clock Duty Cycle at $V_{DD} / 2$	45	50	55	%
OE_H	Output enable time, OE high to output on		50		ns
OE_L	Output disable time, OE low to tri-state		50		ns
$t_{jitter (rms)}$	Period Jitter (rms, 1 σ)		25		ps
$t_{jitter (pk-to-pk)}$	Total Period Jitter, (peak-to-peak)		± 70		ps
t_r/t_f	Output rise/fall time (0.8 V to 2.0 V) (measured with 15 pF load)		1		ns

4. The crystal should be fundamental mode, parallel resonant. Do not use third overtone. For exact tuning when using a crystal, capacitors should be connected from pins X1/CLK to GND and X2 to GND. The value of these capacitors is given by the following equation, where C_L is the specified crystal load capacitance: Crystal capacitance (pF) = $(C_L - 12) \times 2$. So, for a crystal with 16 pF load capacitance, use two 8 pF capacitors.

NB3N501

APPLICATIONS INFORMATION

High Frequency CMOS/TTL Oscillators

The NB3N501, along with a low frequency fundamental mode crystal, can build a high frequency TTL output oscillator. For example, a 20 MHz crystal connected to the NB3N501 with the 5X output selected (S1 = L, S0 = H) produces an 100 MHz CMOS/TTL output clock.

Decoupling and External Components

The NB3N501 requires a 0.01 μ F decoupling capacitor to be connected between V_{DD} and GND on pins 2 and 3. It must be connected close to the NB3N501 to minimize lead inductance. Control input pins can be connected to device pins V_{DD} or GND, or to the V_{DD} and GND planes on the board.

Series Termination Resistor

A 33 Ω terminating resistor can be used next to the CLK pin for trace lengths over one inch.

Crystal Load Capacitors

The total on chip capacitance is approximately 12 pF. A parallel resonant, fundamental mode crystal should be used. The device crystal connections should include pads for small capacitors from X1 to ground and from X2 to ground. These capacitors are used to adjust the stray capacitance of the board to match the nominally required crystal load capacitance. Because load capacitance can only be increased in this trimming process, it is important to keep stray capacitance to a minimum by using very short PCB traces (and no vias) between the crystal and device. Crystal capacitors, if needed, must be connected from each of the pins X1 and X2 to ground. The value (in pF) of these crystal caps should equal $(C_L - 12 \text{ pF}) * 2$. In this equation, C_L = crystal load capacitance in pF. Example: For a crystal with a 16 pF load capacitance, each crystal capacitor would be 8 pF $[(16 - 12) \times 2 = 8]$.

ORDERING INFORMATION

Device	Package	Shipping [†]
NB3N501DG	SOIC-8 (Pb-Free)	98 Units / Rail
NB3N501DR2G	SOIC-8 (Pb-Free)	2500 / Tape & Reel

[†]For information on tape and reel specifications, including part orientation and tape sizes, please refer to our Tape and Reel Packaging Specification Brochure, BRD8011/D.

NB3N501

PACKAGE DIMENSIONS

SOIC-8 NB CASE 751-07 ISSUE AK

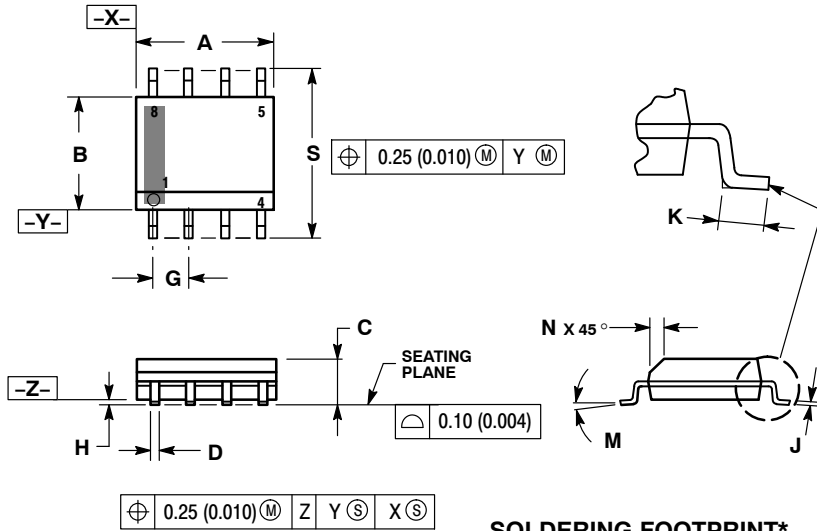

NOTES:

1. DIMENSIONING AND TOLERANCING PER ANSI Y14.5M, 1982.
2. CONTROLLING DIMENSION: MILLIMETER.
3. DIMENSION A AND B DO NOT INCLUDE MOLD PROTRUSION.
4. MAXIMUM MOLD PROTRUSION 0.15 (0.006) PER SIDE.
5. DIMENSION D DOES NOT INCLUDE DAMBAR PROTRUSION. ALLOWABLE DAMBAR PROTRUSION SHALL BE 0.127 (0.005) TOTAL IN EXCESS OF THE D DIMENSION AT MAXIMUM MATERIAL CONDITION.
6. 751-01 THRU 751-06 ARE OBSOLETE. NEW STANDARD IS 751-07.

DIM	MILLIMETERS		INCHES	
	MIN	MAX	MIN	MAX
A	4.80	5.00	0.189	0.197
B	3.80	4.00	0.150	0.157
C	1.35	1.75	0.053	0.069
D	0.33	0.51	0.013	0.020
G	1.27 BSC		0.050 BSC	
H	0.10	0.25	0.004	0.010
J	0.19	0.25	0.007	0.010
K	0.40	1.27	0.016	0.050
M	0°	8°	0°	8°
N	0.25	0.50	0.010	0.020
S	5.80	6.20	0.228	0.244

SOLDERING FOOTPRINT*

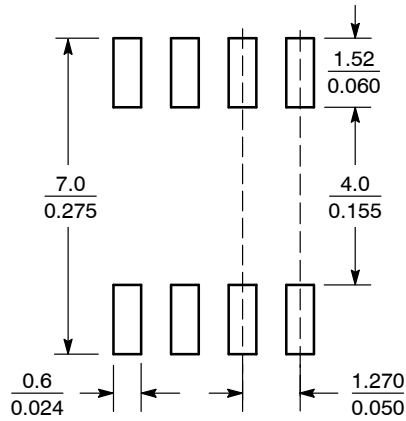

SCALE 6:1 $\left(\frac{\text{mm}}{\text{inches}}\right)$

*For additional information on our Pb-Free strategy and soldering details, please download the ON Semiconductor Soldering and Mounting Techniques Reference Manual, SOLDERRM/D.

ON Semiconductor and are registered trademarks of Semiconductor Components Industries, LLC (SCILLC). SCILLC reserves the right to make changes without further notice to any products herein. SCILLC makes no warranty, representation or guarantee regarding the suitability of its products for any particular purpose, nor does SCILLC assume any liability arising out of the application or use of any product or circuit, and specifically disclaims any and all liability, including without limitation special, consequential or incidental damages. "Typical" parameters which may be provided in SCILLC data sheets and/or specifications can and do vary in different applications and actual performance may vary over time. All operating parameters, including "Typicals" must be validated for each customer application by customer's technical experts. SCILLC does not convey any license under its patent rights nor the rights of others. SCILLC products are not designed, intended, or authorized for use as components in systems intended for surgical implant into the body, or other applications intended to support or sustain life, or for any other application in which the failure of the SCILLC product could create a situation where personal injury or death may occur. Should Buyer purchase or use SCILLC products for any such unintended or unauthorized application, Buyer shall indemnify and hold SCILLC and its officers, employees, subsidiaries, affiliates, and distributors harmless against all claims, costs, damages, and expenses, and reasonable attorney fees arising out of, directly or indirectly, any claim of personal injury or death associated with such unintended or unauthorized use, even if such claim alleges that SCILLC was negligent regarding the design or manufacture of the part. SCILLC is an Equal Opportunity/Affirmative Action Employer. This literature is subject to all applicable copyright laws and is not for resale in any manner.

PUBLICATION ORDERING INFORMATION

LITERATURE FULFILLMENT:

Literature Distribution Center for ON Semiconductor
P.O. Box 5163, Denver, Colorado 80217 USA
Phone: 303-675-2175 or 800-344-3860 Toll Free USA/Canada
Fax: 303-675-2176 or 800-344-3867 Toll Free USA/Canada
Email: orderlit@onsemi.com

N. American Technical Support: 800-282-9855 Toll Free
USA/Canada
Europe, Middle East and Africa Technical Support:
Phone: 421 33 790 2910
Japan Customer Focus Center
Phone: 81-3-5817-1050

ON Semiconductor Website: www.onsemi.com

Order Literature: <http://www.onsemi.com/orderlit>

For additional information, please contact your local Sales Representative

Looking for pricing, stock, or lifecycle information?

Click below to explore more details on WIN SOURCE:

 [View NB3N501DG on WIN SOURCE](#)

 [ON Semiconductor](#) Information

Optimize Your Supply Chain with WIN SOURCE Solutions

-  Global Sourcing Solution
-  Obsolete Management
-  Cost Control Management
-  Shortage Management
-  Alternative Solution
-  Excess Inventory Management