



**THE DATASHEET OF
NB4N507ADG**



3.3 V/5 V, 50 MHz to 200 MHz PECL Clock Synthesizer

NB4N507A

Description

The NB4N507A is a precision clock synthesizer which generates a very low jitter differential PECL output clock. It produces a clock output based on an integer multiple of an input reference frequency.

The NB4N507A accepts a standard fundamental mode crystal, using Phase-Locked-Loop (PLL) techniques, will produce output clocks up to 200 MHz. In addition, the PLL circuitry will produce a 50% duty cycle square-wave clock output (see Figure 7).

The NB4N507A can be programmed to generate a selection of input reference frequency multiples. An exact 155.52 MHz output clock can be generated from a 19.44 MHz crystal and the x8 multiplier selection. The NB4N507A is intended for low output jitter clock generation.

The PECL outputs are 15 mA open collector and must be DC loaded and AC terminated. See Figures 4 and 6.

Features

- Input Crystal Frequency of 10 – 27 MHz
- Enable Usage of Common Low-Cost Crystal
- Differential PECL Output Clock Frequencies up to 200 MHz
- Duty Cycle of 48%/52%
- Operating Range: $V_{CC} = 3.0\text{ V to }5.5\text{ V}$
- Ideal for SONET Applications and Oscillator Manufacturers
- Available in Die Form
- Packaged in 16-Pin Narrow SOIC
- Pb-Free Packages are Available*

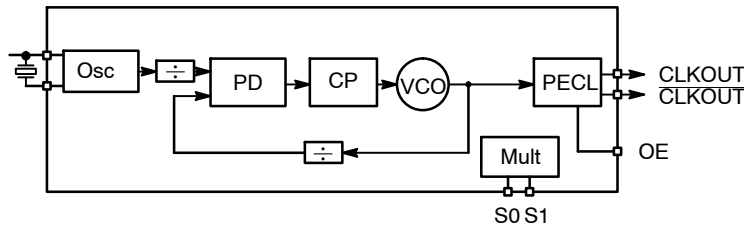
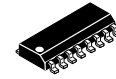
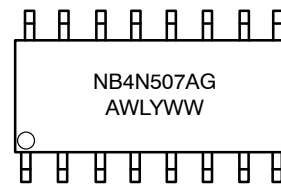

Figure 1. Simplified Logic Block Diagram



SOIC-16
D SUFFIX
CASE 751B-05

MARKING DIAGRAM



A = Assembly Location
WL = Wafer Lot
Y = Year
WW = Work Week
G = Pb-Free Package

ORDERING INFORMATION

See detailed ordering and shipping information in the package dimensions section on page 6 of this data sheet.

NOTE: Some of the devices on this data sheet have been **DISCONTINUED**. Please refer to the table on page 6.

*For additional information on our Pb-Free strategy and soldering details, please download the onsemi Soldering and Mounting Techniques Reference Manual, SOLDERRM/D.

NB4N507A

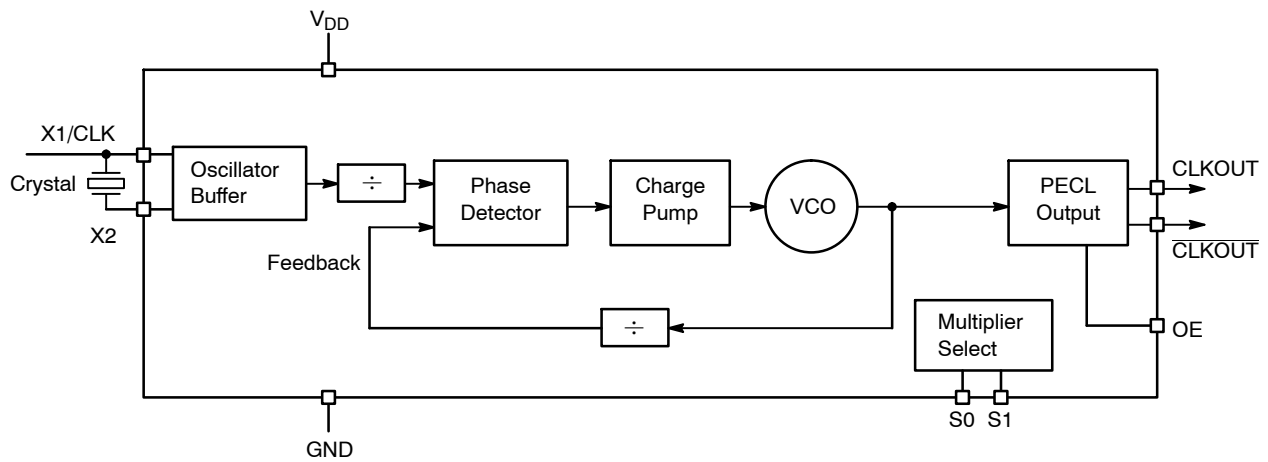

Figure 2. NB4N507A Logic Diagram

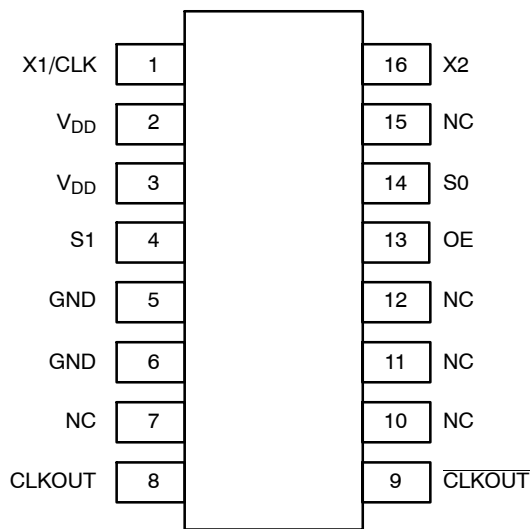

Figure 3. 16-Pin SOIC (Top View)

Table 1. CLOCK MULTIPLIER SELECT TABLE

S1	S0	Multiplier
L	L	9.72X*
L	M	10X
L	H	12X
M	L	6.25X
M	M	8X
M	H	5X
H	L	NA
H	M	3X
H	H	4X

*Example Crystal = 16 MHz, $f_{CLKOUT} = 155.52$ MHz
 L = GND
 H = V_{DD}
 M = OPEN

Table 2. OE, OUTPUT ENABLE FUNCTION

OE	Function
0	Disable
1	Enable

NB4N507A

Table 3. PIN DESCRIPTION

Pin # SOIC-16	Name	I/O	Description
1	X1/CLK	Crystal Input	Crystal or Clock Input
2,3	V _{DD}	Power Supply	Positive Supply Voltage (3.0 V to 5.5 V)
4	S1	Tri-Level Input	Multiplier Select Pin; When Left Open, Defaults to V _{DD} ÷ 2
5,6	GND	Power Supply	Negative Supply Voltage
7,10,11,12, 15	NC	No Connect	Pin 10 does not require an external resistor. The NB4N507A will function with or without a resistor on Pin 10.
8	CLKOUT	PECL Output*	Non-inverted differential PECL clock output.
9	$\overline{\text{CLKOUT}}$	PECL Output*	Inverted differential PECL clock output.
13	OE	(LV)CMOS/(LV)TTL Input	Output Enable for the CLKOUT/CLKOUT Outputs. Outputs are enabled when HIGH or when left open; OE pin has internal pullup resistor. Disables both outputs when LOW. CLKOUT goes LOW, $\overline{\text{CLKOUT}}$ goes HIGH.
14	S0	Tri-Level Input	Multiplier Select Pin; When Left Open, Defaults to V _{DD} ÷ 2
16	X2	Crystal Input	Crystal Input

*The PECL Outputs are 15 mA open collector and must be DC loaded and AC terminated. See Figures 4, 5 and 6.

Table 4. ATTRIBUTES

Characteristics	Value
ESD Protection Human Body Model	> 1 kV
Machine Model	> 150 V
Charged Device Model	> 1 kV
Moisture Sensitivity, Indefinite Time Out of Drypack (Note 1)	Level 1
Flammability Rating Oxygen Index: 28 to 34	UL 94 V-0 @ 0.125 in
Transistor Count	1145 Devices
Meets or exceeds JEDEC Spec EIA/JESD78 IC Latchup Test	

1. For additional information, see Application Note AND8003/D.

Table 5. MAXIMUM RATINGS

Symbol	Parameter	Condition 1	Condition 2	Rating	Unit
V _{CC}	Positive Power Supply	GND = 0 V		6	V
V _I	Input Voltage			GND - 0.5 ≤ V _I ≤ V _{DD} + 0.5	V
T _A	Operating Temperature Range			-40 to +85	°C
T _{stg}	Storage Temperature Range			-65 to +150	°C
θ _{JA}	Thermal Resistance (Junction-to-Ambient)	0 lfpm 500 lfpm	SOIC-16	100 60	°C/W °C/W
θ _{JC}	Thermal Resistance (Junction-to-Case)	(Note 2)	SOIC-16	33 to 36	°C/W
T _{sol}	Wave Solder Pb Pb-Free	< 3 sec @ 248°C < 3 sec @ 260°C		265 265	°C

Stresses exceeding those listed in the Maximum Ratings table may damage the device. If any of these limits are exceeded, device functionality should not be assumed, damage may occur and reliability may be affected.

2. JEDEC standard multilayer board – 2S2P (2 signal, 2 power).

NB4N507A

Table 6. DC CHARACTERISTICS ($V_{DD} = 3.0\text{ V to }5.5\text{ V}$, $GND = 0\text{ V}$, $T_A = -40^\circ\text{C to }+85^\circ\text{C}$ (Note 3))

Symbol	Characteristic	Min	Typ	Max	Unit
I_{DD}	Power Supply Current $V_{DD} = 5\text{ V}$ (does not include output load resistor current) $V_{DD} = 3.3\text{ V}$	15 10	27 23	35 30	mA mA
V_{OH}	Output HIGH Voltage (Notes 5 & 6) $V_{DD} = 3.3\text{ V}$	3.95 2.57	4.05 2.67	4.15 2.77	V
V_{OL}	Output LOW Voltage (Notes 5 & 6) $V_{DD} = 3.3\text{ V}$	3.12 1.90	3.20 2.00	3.30 2.10	V
V_{IH}	Input HIGH Voltage (Note 4) S0, S1, X1/CLK OE	$V_{DD} - 0.5$ 2.0		V_{DD}	V
V_{IL}	Input LOW Voltage, (Note 4) S0, S1, X1/CLK OE	0		0.5 0.8	V
C_x	Internal Crystal Capacitance, X1 & X2		0		pF
C_{in}	Input Capacitance, S0, S1, OE		5.0		pF

NOTE: Device will meet the specifications after thermal equilibrium has been established when mounted in a test socket or printed circuit board with maintained transverse airflow greater than 500 lfm.

- PECL output parameters vary 1:1 with V_{DD} .
- S0 and S1 default to $V_{DD} \div 2$ when left open.

Table 7. AC CHARACTERISTICS ($V_{DD} = 3.0\text{ V to }5.5\text{ V}$, $GND = 0\text{ V}$, $T_A = -40^\circ\text{C to }+85^\circ\text{C}$ (Note 5))

Symbol	Characteristic	Min	Typ	Max	Unit
f_{xtal}	Crystal Input Frequency (Note 7)	10		27	MHz
f_{CLK}	Input Clock Frequency (Note 8)	5		52	MHz
f_{OUT}	Output Frequency Range	50		200	MHz
$V_{out\ pk-pk}$	Output Amplitude	550	680		mV
DC	Clock Output Duty Cycle (Note 8)	48		52	%
PLL _{BW}	PLL Bandwidth (Note 8)	10			kHz
$t_{jitter\ (pd)}$	Period Jitter (RMS, 1 σ , 10,000 Cycles)			10	ps
$t_{jitter\ (pd)}$	Period Jitter (Peak-to-Peak, 10,000 Cycles)			± 20	ps
t_r/t_f	Output Rise and Fall Times (Note 8)	50	270	500	ps

NOTE: Device will meet the specifications after thermal equilibrium has been established when mounted in a test socket or printed circuit board with maintained transverse airflow greater than 500 lfm.

- PECL outputs loaded with external resistors for proper operation (see Figures 4, 5 and 6).
- V_{OH} and V_{OL} can be set by the external resistors, which can be modified.
- The crystal should be fundamental mode, parallel resonant. Do not use third overtone. For exact tuning when using a crystal, capacitors should be connected from pins X1 to ground and X2 to ground. The value of these capacitors is given by the following equation, where CL is the specified crystal load capacitance: Crystal caps (pF) = $(CL - 5) \times 2$. So, for a crystal with 16 pF load capacitance, use two 22 pF caps, including board trace capacitance (see Figure 7).
- Guaranteed by design and characterization.

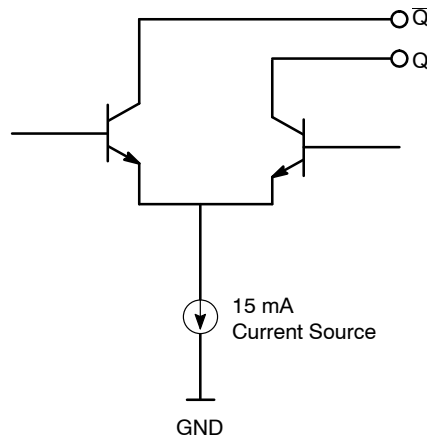

Figure 4. Output Structure

NB4N507A

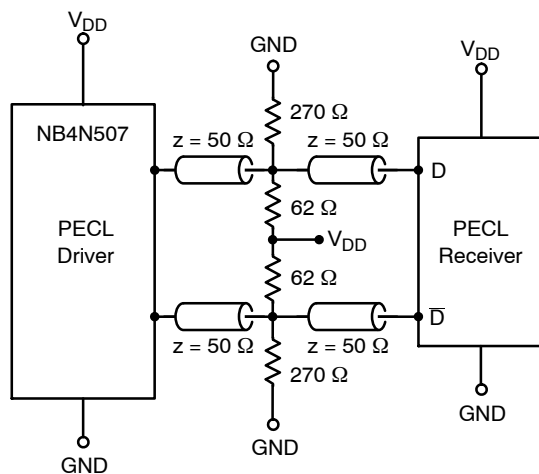

Figure 5. Evaluation Test Load for the NB4N507A

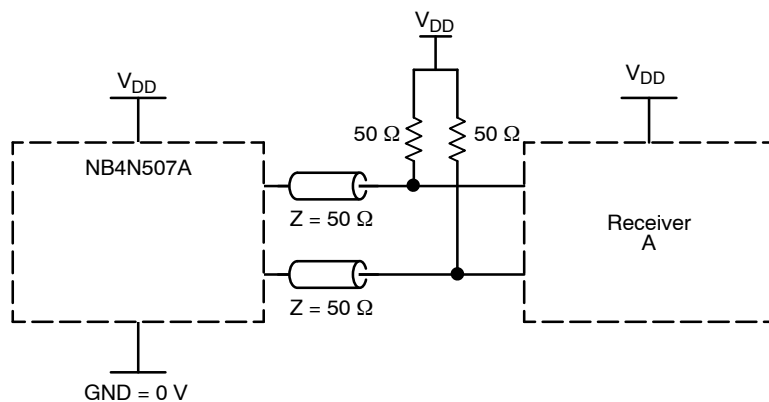

Figure 6. Alternate Termination for Output Driver and Device Evaluation

NB4N507A

APPLICATIONS INFORMATION

High Frequency Differential PECL Oscillators: The NB4N507A, along with a low frequency fundamental mode crystal, can build a high frequency differential PECL output oscillator. For example, a 10 MHz crystal connected to the NB4N507A with the 12X output selected (S1 = 0, S0 = 1) produces a 120 MHz PECL output clock.

Crystal Oscillator Input Interface

The NB4N507A features an integrated crystal oscillator to minimize system implementation costs. The oscillator circuit is a parallel resonant circuit and thus, for optimum performance, a parallel resonant crystal should be used.

As the oscillator is somewhat sensitive to loading on its inputs, the user is advised to mount the crystal as close to the NB4N507A as possible to avoid any board level parasitics. Surface mount crystals are recommended, but not required.

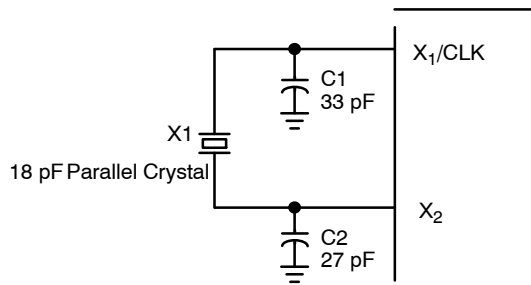

Figure 7. Crystal Input Interface

High Frequency VCXO: The bandwidth of the PLL is guaranteed to be greater than 10 kHz. This means that the PLL will track any modulation on the input with a frequency of less than 10 kHz. By using this property, a low frequency VCXO can be built. The output can then be multiplied by the NB4N507A, thereby producing a high frequency VCXO.

High Frequency TCXO: Extending the previous application, an inexpensive, low frequency TCXO can be built and the output frequency can be multiplied using the NB4N507A. Since the output of the chip is phase-locked to the input, the NB4N507A has no temperature dependence, and the temperature coefficient of the combined system is the same as that of the low frequency TCXO.

Decoupling and External Components

The NB4N507A requires a 0.01 μ F decoupling capacitor to be connected between V_{DD} and GND on pins 2 and 5. It must be connected close to the NB4N507A. Other V_{DD} and GND connections should be connected to those pins, or to the V_{DD} and GND planes on the board. Another four resistors are needed for the PECL outputs as shown in Figure 4. Suggested values of these resistors are shown, but they can be varied to change the differential pair output swing, and the DC level.

ORDERING INFORMATION

Device	Package	Shipping [†]
NB4N507ADR2G	SOIC-16 (Pb-Free)	2500 / Tape & Reel

DISCONTINUED (Note 9)

NB4N507ADG	SOIC-16 (Pb-Free)	48 Units / Rail
------------	----------------------	-----------------

[†]For information on tape and reel specifications, including part orientation and tape sizes, please refer to our Tape and Reel Packaging Specifications Brochure, BRD8011/D.

9. **DISCONTINUED:** This device is not recommended for new design. Please contact your onsemi representative for information. The most current information on this device may be available on www.onsemi.com.

NB4N507A

Resource Reference of Application Notes

- AN1405/D** – ECL Clock Distribution Techniques
- AN1406/D** – Designing with PECL (ECL at +5.0 V)
- AN1503/D** – ECLinPS™ I/O SPiCE Modeling Kit
- AN1504/D** – Metastability and the ECLinPS Family
- AN1568/D** – Interfacing Between LVDS and ECL
- AN1672/D** – The ECL Translator Guide
- AND8001/D** – Odd Number Counters Design
- AND8002/D** – Marking and Date Codes
- AND8020/D** – Termination of ECL Logic Devices
- AND8066/D** – Interfacing with ECLinPS
- AND8090/D** – AC Characteristics of ECL Devices

ECLinPS is a trademark of Semiconductor Components Industries, LLC dba "onsemi" or its affiliates and/or subsidiaries in the United States and/or other countries.

MECHANICAL CASE OUTLINE

PACKAGE DIMENSIONS



SOIC-16 9.90x3.90x1.50 1.27P
CASE 751B
ISSUE L

DATE 29 MAY 2024

NOTES:

1. DIMENSIONING AND TOLERANCING PER ASME Y14.5M, 2018.
2. DIMENSION IN MILLIMETERS. ANGLE IN DEGREES.
3. DIMENSIONS D AND E1 DO NOT INCLUDE MOLD PROTRUSION.
4. MAXIMUM MOLD PROTRUSION 0.15mm PER SIDE.
5. DIMENSION b DOES NOT INCLUDE DAMBAR PROTRUSION. ALLOWABLE DAMBAR PROTRUSION SHALL BE 0.127mm TOTAL IN EXCESS OF THE b DIMENSION AT MAXIMUM MATERIAL CONDITION.

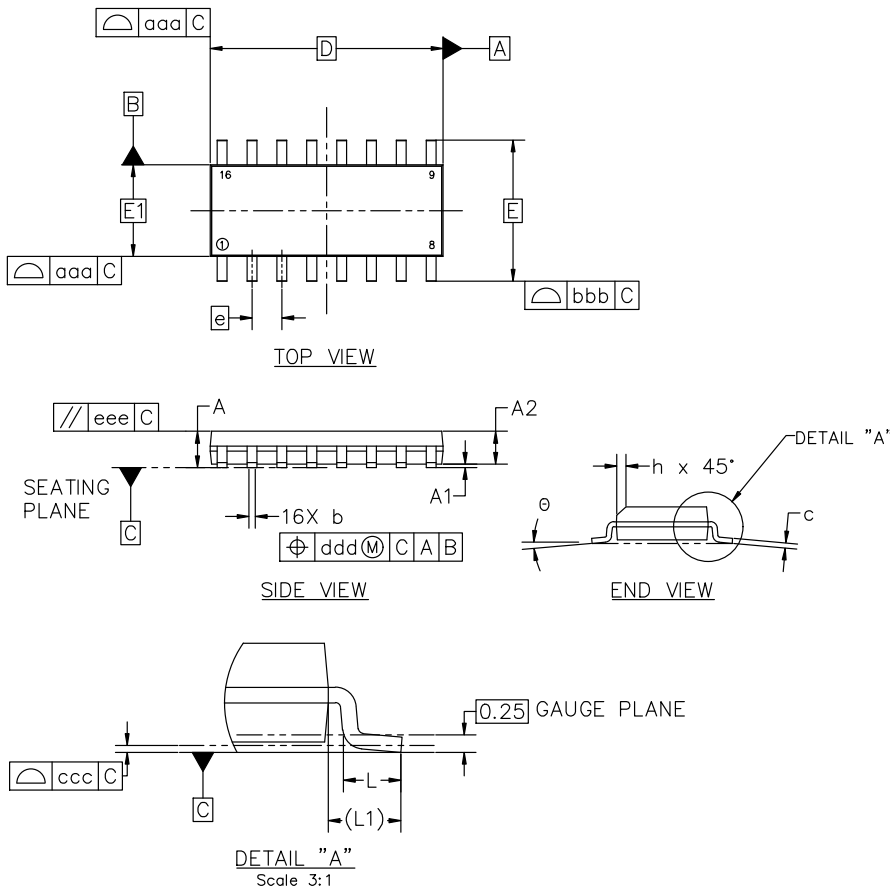

MILLIMETERS			
DIM	MIN	NOM	MAX
A	1.35	1.55	1.75
A1	0.00	0.05	0.10
A2	1.35	1.50	1.65
b	0.35	0.42	0.49
c	0.19	0.22	0.25
D	9.90 BSC		
E	6.00 BSC		
E1	3.90 BSC		
e	1.27 BSC		
h	0.25	---	0.50
L	0.40	0.83	1.25
L1	1.05 REF		
θ	0°	---	7°
TOLERANCE OF FORM AND POSITION			
aaa	0.10		
bbb	0.20		
ccc	0.10		
ddd	0.25		
eee	0.10		

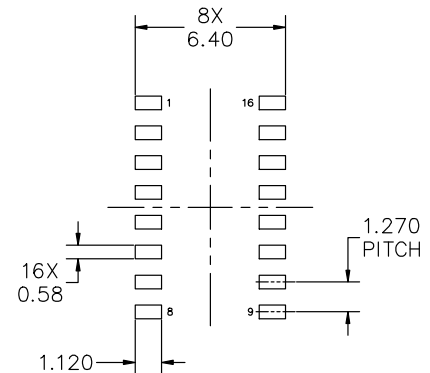

RECOMMENDED MOUNTING FOOTPRINT

*FOR ADDITIONAL INFORMATION ON OUR PB-FREE STRATEGY AND SOLDERING DETAILS, PLEASE DOWNLOAD THE onsemi SOLDERING AND MOUNTING TECHNIQUES REFERENCE MANUAL, SOLDERRM/D

DOCUMENT NUMBER:	98ASB42566B	Electronic versions are uncontrolled except when accessed directly from the Document Repository. Printed versions are uncontrolled except when stamped "CONTROLLED COPY" in red.
DESCRIPTION:	SOIC-16 9.90X3.90X1.50 1.27P	PAGE 1 OF 2

onsemi and onsemi are trademarks of Semiconductor Components Industries, LLC dba onsemi or its subsidiaries in the United States and/or other countries. onsemi reserves the right to make changes without further notice to any products herein. onsemi makes no warranty, representation or guarantee regarding the suitability of its products for any particular purpose, nor does onsemi assume any liability arising out of the application or use of any product or circuit, and specifically disclaims any and all liability, including without limitation special, consequential or incidental damages. onsemi does not convey any license under its patent rights nor the rights of others.

MECHANICAL CASE OUTLINE
PACKAGE DIMENSIONS



SOIC-16 9.90x3.90x1.50 1.27P
CASE 751B
ISSUE L

DATE 29 MAY 2024

GENERIC MARKING DIAGRAM*

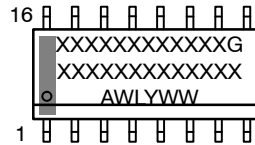

XXXXX = Specific Device Code
 A = Assembly Location
 WL = Wafer Lot
 Y = Year
 WW = Work Week
 G = Pb-Free Package

*This information is generic. Please refer to device data sheet for actual part marking. Pb-Free indicator, "G" or microdot "•", may or may not be present. Some products may not follow the Generic Marking.

<p>STYLE 1: PIN 1. COLLECTOR 2. BASE 3. EMITTER 4. NO CONNECTION 5. EMITTER 6. BASE 7. COLLECTOR 8. COLLECTOR 9. BASE 10. EMITTER 11. NO CONNECTION 12. EMITTER 13. BASE 14. COLLECTOR 15. EMITTER 16. COLLECTOR</p>	<p>STYLE 2: PIN 1. CATHODE 2. ANODE 3. NO CONNECTION 4. CATHODE 5. CATHODE 6. NO CONNECTION 7. ANODE 8. CATHODE 9. CATHODE 10. ANODE 11. NO CONNECTION 12. CATHODE 13. CATHODE 14. NO CONNECTION 15. ANODE 16. CATHODE</p>	<p>STYLE 3: PIN 1. COLLECTOR, DYE #1 2. BASE, #1 3. EMITTER, #1 4. COLLECTOR, #1 5. COLLECTOR, #2 6. BASE, #2 7. EMITTER, #2 8. COLLECTOR, #2 9. COLLECTOR, #3 10. BASE, #3 11. EMITTER, #3 12. COLLECTOR, #3 13. COLLECTOR, #4 14. BASE, #4 15. EMITTER, #4 16. COLLECTOR, #4</p>	<p>STYLE 4: PIN 1. COLLECTOR, DYE #1 2. COLLECTOR, #1 3. COLLECTOR, #2 4. COLLECTOR, #2 5. COLLECTOR, #3 6. COLLECTOR, #3 7. COLLECTOR, #4 8. COLLECTOR, #4 9. BASE, #4 10. EMITTER, #4 11. BASE, #3 12. EMITTER, #3 13. BASE, #2 14. EMITTER, #2 15. BASE, #1 16. EMITTER, #1</p>
<p>STYLE 5: PIN 1. DRAIN, DYE #1 2. DRAIN, #1 3. DRAIN, #2 4. DRAIN, #2 5. DRAIN, #3 6. DRAIN, #3 7. DRAIN, #4 8. DRAIN, #4 9. GATE, #4 10. SOURCE, #4 11. GATE, #3 12. SOURCE, #3 13. GATE, #2 14. SOURCE, #2 15. GATE, #1 16. SOURCE, #1</p>	<p>STYLE 6: PIN 1. CATHODE 2. CATHODE 3. CATHODE 4. CATHODE 5. CATHODE 6. CATHODE 7. CATHODE 8. CATHODE 9. ANODE 10. ANODE 11. ANODE 12. ANODE 13. ANODE 14. ANODE 15. ANODE 16. ANODE</p>	<p>STYLE 7: PIN 1. SOURCE N-CH 2. COMMON DRAIN (OUTPUT) 3. COMMON DRAIN (OUTPUT) 4. GATE P-CH 5. COMMON DRAIN (OUTPUT) 6. COMMON DRAIN (OUTPUT) 7. COMMON DRAIN (OUTPUT) 8. SOURCE P-CH 9. SOURCE P-CH 10. COMMON DRAIN (OUTPUT) 11. COMMON DRAIN (OUTPUT) 12. COMMON DRAIN (OUTPUT) 13. GATE N-CH 14. COMMON DRAIN (OUTPUT) 15. COMMON DRAIN (OUTPUT) 16. SOURCE N-CH</p>	

DOCUMENT NUMBER:	98ASB42566B	Electronic versions are uncontrolled except when accessed directly from the Document Repository. Printed versions are uncontrolled except when stamped "CONTROLLED COPY" in red.
DESCRIPTION:	SOIC-16 9.90X3.90X1.50 1.27P	PAGE 2 OF 2

onsemi and onsemi are trademarks of Semiconductor Components Industries, LLC dba onsemi or its subsidiaries in the United States and/or other countries. onsemi reserves the right to make changes without further notice to any products herein. onsemi makes no warranty, representation or guarantee regarding the suitability of its products for any particular purpose, nor does onsemi assume any liability arising out of the application or use of any product or circuit, and specifically disclaims any and all liability, including without limitation special, consequential or incidental damages. onsemi does not convey any license under its patent rights nor the rights of others.

onsemi, **Onsemi**, and other names, marks, and brands are registered and/or common law trademarks of Semiconductor Components Industries, LLC dba "**onsemi**" or its affiliates and/or subsidiaries in the United States and/or other countries. **onsemi** owns the rights to a number of patents, trademarks, copyrights, trade secrets, and other intellectual property. A listing of **onsemi**'s product/patent coverage may be accessed at www.onsemi.com/site/pdf/Patent-Marking.pdf. **onsemi** reserves the right to make changes at any time to any products or information herein, without notice. The information herein is provided "as-is" and **onsemi** makes no warranty, representation or guarantee regarding the accuracy of the information, product features, availability, functionality, or suitability of its products for any particular purpose, nor does **onsemi** assume any liability arising out of the application or use of any product or circuit, and specifically disclaims any and all liability, including without limitation special, consequential or incidental damages. Buyer is responsible for its products and applications using **onsemi** products, including compliance with all laws, regulations and safety requirements or standards, regardless of any support or applications information provided by **onsemi**. "Typical" parameters which may be provided in **onsemi** data sheets and/or specifications can and do vary in different applications and actual performance may vary over time. All operating parameters, including "Typicals" must be validated for each customer application by customer's technical experts. **onsemi** does not convey any license under any of its intellectual property rights nor the rights of others. **onsemi** products are not designed, intended, or authorized for use as a critical component in life support systems or any FDA Class 3 medical devices or medical devices with a same or similar classification in a foreign jurisdiction or any devices intended for implantation in the human body. Should Buyer purchase or use **onsemi** products for any such unintended or unauthorized application, Buyer shall indemnify and hold **onsemi** and its officers, employees, subsidiaries, affiliates, and distributors harmless against all claims, costs, damages, and expenses, and reasonable attorney fees arising out of, directly or indirectly, any claim of personal injury or death associated with such unintended or unauthorized use, even if such claim alleges that **onsemi** was negligent regarding the design or manufacture of the part. **onsemi** is an Equal Opportunity/Affirmative Action Employer. This literature is subject to all applicable copyright laws and is not for resale in any manner.

ADDITIONAL INFORMATION

TECHNICAL PUBLICATIONS:

Technical Library: www.onsemi.com/design/resources/technical-documentation
onsemi Website: www.onsemi.com

ONLINE SUPPORT: www.onsemi.com/support

For additional information, please contact your local Sales Representative at www.onsemi.com/support/sales

Looking for pricing, stock, or lifecycle information?

Click below to explore more details on WIN SOURCE:

 [View NB4N507ADG](#) on WIN SOURCE

 [ON Semiconductor](#) Information

Optimize Your Supply Chain with WIN SOURCE Solutions

-  Global Sourcing Solution
-  Obsolete Management
-  Cost Control Management
-  Shortage Management
-  Alternative Solution
-  Excess Inventory Management