



**THE DATASHEET OF  
PCM2707CPJT**



# PCM270xC Stereo Audio DAC With USB Interface, Single-Ended Headphone Output and S/PDIF Output

## 1 Features

- On-Chip USB Interface:
  - No Dedicated Device Driver Needed
  - Full-Speed Transceivers
  - Fully Compliant With USB 2.0 Specification
    - USB 1.1 Descriptors With USB Audio Class Support
  - Certified by USB-IF
  - Partially Programmable Descriptors
  - Adaptive Isochronous Transfer for Playback
  - Bus-Powered or Self-Powered Operation
- Sampling Rates: 32 kHz, 44.1 kHz, and 48 kHz
- On-Chip Clock Generator With Single 12-MHz Clock Source
- Single Power Supply:
  - Bus-Powered: 5 V, Typical ( $V_{BUS}$ )
  - Self-Powered: 3.3 V, Typical
- 16-Bit Delta-Sigma Stereo DAC
  - Analog Performance at 5 V (Bus-Powered), 3.3 V (Self-Powered):
    - THD + N: 0.006%  $R_L > 10\text{ k}\Omega$ , Self-Powered
    - THD + N: 0.025%  $R_L = 32\ \Omega$
    - SNR = 98 dB
    - Dynamic Range: 98 dB
    - $P_O = 12\text{ mW}$ ,  $R_L = 32\ \Omega$
  - Oversampling Digital Filter
    - Passband Ripple =  $\pm 0.04\text{ dB}$
    - Stop-Band Attenuation =  $-50\text{ dB}$
  - Single-Ended Voltage Output
  - Analog LPF Included
- Multiple Functions:
  - Up to Eight Human Interface Device (HID) Interfaces (Model and Setting Dependent)
  - Suspend Flag
  - S/PDIF Out With SCMS
  - External ROM Interface (PCM2704C/6C)
  - Serial Programming Interface (PCM2705C/7C)
  - I<sup>2</sup>S Interface (Selectable on PCM2706C/7C)

## 2 Applications

- USB Headphones
- USB Audio Speaker
- USB CRT/LCD Monitor
- USB Audio Interface Box
- USB-Featured Consumer Audio Product

## 3 Description

The PCM270xC are TI's single-chip USB stereo audio digital-to-analog converters (DACs) with USB 2.0 compliant full-speed protocol controller and S/PDIF. The USB-protocol controller works with no software code, but USB descriptors can be modified in some areas (for example, vendor ID/product ID) through the use of an external ROM (PCM2704C and PCM2706C) or serial peripheral interface (SPI) (PCM2705C and PCM2707C). The PCM270xC also employ SpAct™ architecture, TI's unique system that recovers the audio clock from USB packet data. On-chip analog phase-locked loops (PLLs) with SpAct enable playback with low clock jitter.

### Device Information<sup>(1)</sup>

PART NUMBER	PACKAGE	BODY SIZE (NOM)
PCM2704C	SSOP (28)	5.30 mm x 10.20 mm
PCM2705C		
PCM2706C	TQFP (32)	7.00 mm x 7.00 mm
PCM2707C		

(1) For all available packages, see the orderable addendum at the end of the data sheet.

### Block Diagram

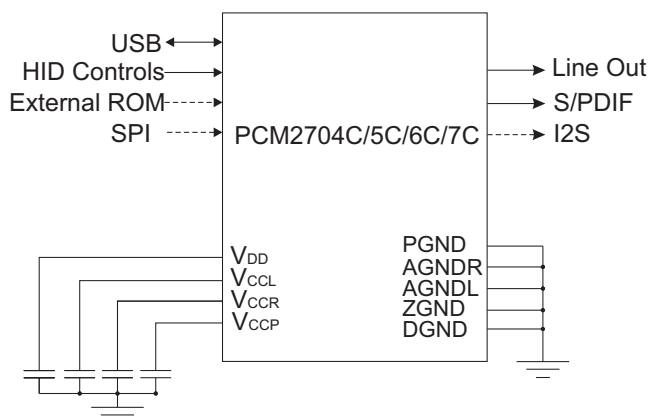

## Table of Contents

<b>1 Features</b> .....	<b>1</b>	9.1 Overview .....	<b>18</b>
<b>2 Applications</b> .....	<b>1</b>	9.2 Functional Block Diagrams .....	<b>18</b>
<b>3 Description</b> .....	<b>1</b>	9.3 Feature Description .....	<b>20</b>
<b>4 Revision History</b> .....	<b>2</b>	9.4 Device Functional Modes .....	<b>25</b>
<b>5 Device Comparison Table</b> .....	<b>3</b>	9.5 Programming .....	<b>26</b>
<b>6 Pin Configuration and Functions</b> .....	<b>4</b>	9.6 Register Maps .....	<b>29</b>
<b>7 Specifications</b> .....	<b>7</b>	<b>10 Application and Implementation</b> .....	<b>30</b>
7.1 Absolute Maximum Ratings .....	<b>7</b>	10.1 Application Information .....	<b>30</b>
7.2 ESD Ratings .....	<b>7</b>	10.2 Typical Application .....	<b>30</b>
7.3 Recommended Operating Conditions .....	<b>8</b>	<b>11 Power Supply Recommendations</b> .....	<b>37</b>
7.4 Thermal Information: PCM2704C, PCM2705C .....	<b>8</b>	<b>12 Layout</b> .....	<b>37</b>
7.5 Thermal Information: PCM2706C, PCM2707C .....	<b>8</b>	12.1 Layout Guidelines .....	<b>37</b>
7.6 Electrical Characteristics: PCM2704CDB, PCM2705CDB, PCM2706CPJT, PCM2707CPJT .....	<b>9</b>	12.2 Layout Example .....	<b>37</b>
7.7 Audio Interface Timing Characteristics .....	<b>11</b>	<b>13 Device and Documentation Support</b> .....	<b>40</b>
7.8 Audio Clock Timing Characteristics .....	<b>11</b>	13.1 Documentation Support .....	<b>40</b>
7.9 External ROM Read Interface Timing Characteristics .....	<b>11</b>	13.2 Related Links .....	<b>40</b>
7.10 SPI Timing Characteristics .....	<b>12</b>	13.3 Community Resources .....	<b>40</b>
7.11 Typical Characteristics .....	<b>14</b>	13.4 Trademarks .....	<b>40</b>
<b>8 Parameter Measurement Information</b> .....	<b>17</b>	13.5 Electrostatic Discharge Caution .....	<b>40</b>
<b>9 Detailed Description</b> .....	<b>18</b>	13.6 Glossary .....	<b>40</b>
		<b>14 Mechanical, Packaging, and Orderable Information</b> .....	<b>40</b>

## 4 Revision History

NOTE: Page numbers for previous revisions may differ from page numbers in the current version.

### Changes from Revision A (July 2012) to Revision B Page

<ul style="list-style-type: none"> <li>Added <i>Handling Ratings</i> table, <i>Feature Description</i> section, <i>Device Functional Modes</i>, <i>Application and Implementation</i> section, <i>Power Supply Recommendations</i> section, <i>Layout</i> section, <i>Device and Documentation Support</i> section, and <i>Mechanical, Packaging, and Orderable Information</i> section .....</li> </ul>	<b>1</b>
--	----------

### Changes from Original (August 2011) to Revision A Page

<ul style="list-style-type: none"> <li>Changed product status from Mixed Status to Production Data .....</li> <li>Changed <i>Features</i> section to show full compliance with USB2.0 Specification (but still using USB1.1 descriptors) .....</li> <li>Changed <i>Description</i> section to show USB2.0 compliance (USB1.1 was absorbed into 2.0 specification) .....</li> </ul>	<b>1</b>
--	----------

## 5 Device Comparison Table

FEATURE	PCM2704C	PCM2705C	PCM2706C	PCM2707C
Supply Voltage (V)	3.3, 5	3.3, 5	3.3, 5	3.3, 5
Control Interface	HID	HID, SPI	HID, SPI	HID, SPI
Additional Features	S/PDIF Output HP Output Ext. ROM I/F	S/PDIF Output HP Output	S/PDIF Output HP Output Ext. ROM I/F	S/PDIF Output HP Output
Package Group	SSOP	SSOP	TQFP	TQFP

## 6 Pin Configuration and Functions

**PCM2704C, PCM2705C DB Package  
28-Pin SSOP  
Top View**

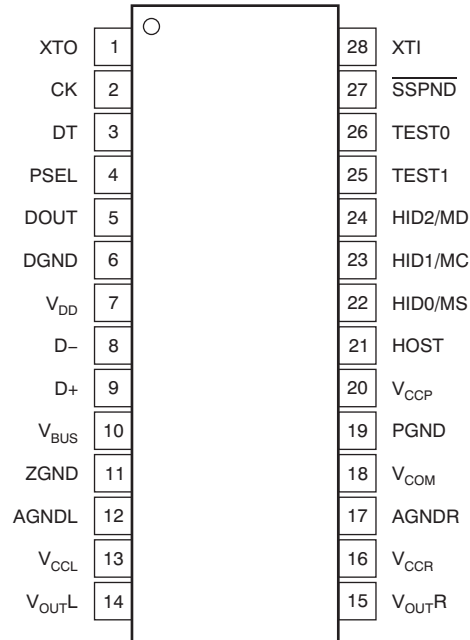

**Pin Functions: DB Package (PCM2704C/PCM2705C)**

PIN		I/O	DESCRIPTION
NAME	NO.		
AGNDL	12	—	Analog ground for headphone amplifier of L-channel
AGNDR	17	—	Analog ground for headphone amplifier of R-channel
CK	2	O	Clock output for external ROM (PCM2704C). Must be left open (PCM2705C).
D+	9	I/O	USB differential input/output plus <sup>(1)</sup>
D-	8	I/O	USB differential input/output minus <sup>(1)</sup>
DGND	6	—	Digital ground
DOUT	5	O	S/PDIF output
DT	3	I/O	Data input/output for external ROM (PCM2704C). Must be left open with pullup resistor (PCM2705C). <sup>(1)</sup>
HID0/MS	22	I	HID key state input (mute), active high (PCM2704C). MS input (PCM2705C) <sup>(2)</sup>
HID1/MC	23	I	HID key state input (volume up), active high (PCM2704C). MC input (PCM2705C) <sup>(2)</sup>
HID2/MD	24	I	HID key state input (volume down), active high (PCM2704C). MD input (PCM2705C) <sup>(2)</sup>
HOST	21	I	Host detection during self-powered operation (connect to V <sub>BUS</sub> ). Max power select during bus-powered operation (low: 100 mA, high: 500 mA). <sup>(3)</sup>
PGND	19	—	Analog ground for DAC, OSC, and PLL
PSEL	4	I	Power source select (low: self-power, high: bus-power) <sup>(1)</sup>
SSPND	27	O	Suspend flag, active low (low: suspend, high: operational)
TEST0	26	I	Test pin. Must be set high <sup>(1)</sup>
TEST1	25	I	Test pin. Must be set high <sup>(1)</sup>
V <sub>BUS</sub>	10	—	Connect to USB power (V <sub>BUS</sub> ) for bus-powered operation. Connect to V <sub>DD</sub> for self-powered operation.
V <sub>CCL</sub>	13	—	Analog power supply for headphone amplifier of L-channel <sup>(4)</sup>

(1) LV-TTL level.

(2) LV-TTL level with internal pulldown

(3) LV-TTL level, 5-V tolerant

(4) Connect decoupling capacitor to GND. Supply 3.3 V for self-powered applications.

**Pin Functions: DB Package (PCM2704C/PCM2705C) (continued)**

PIN		I/O	DESCRIPTION
NAME	NO.		
V <sub>CCP</sub>	20	—	Analog power supply for DAC, OSC, and PLL <sup>(4)</sup>
V <sub>CCR</sub>	16	—	Analog power supply for headphone amplifier of R-channel <sup>(4)</sup>
V <sub>COM</sub>	18	—	Common voltage for DAC (V <sub>CCP</sub> /2). Connect decoupling capacitor to PGND.
V <sub>DD</sub>	7	—	Digital power supply <sup>(4)</sup>
V <sub>OUTL</sub>	14	O	DAC analog output for L-channel
V <sub>OUTR</sub>	15	O	DAC analog output for R-channel
XTI	28	I	Crystal oscillator input <sup>(1)</sup>
XTO	1	O	Crystal oscillator output
ZGND	11	—	Ground for internal regulator

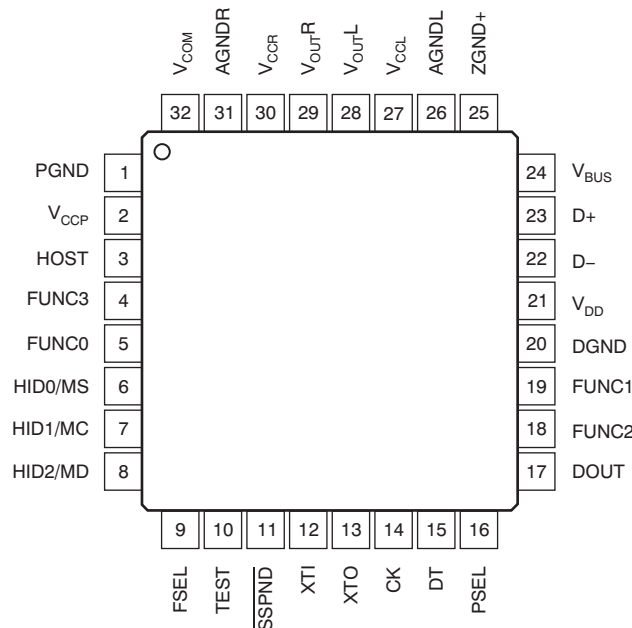
**PCM2706C, PCM2707C PJT Package  
32-Pin TQFP  
Top View**

**Pin Functions: PJT Package (PCM2706C/PCM2707C)**

PIN		I/O	DESCRIPTION
NAME	NO.		
AGNDL	26	—	Analog ground for headphone amplifier of L-channel
AGNDR	31	—	Analog ground for headphone amplifier of R-channel
CK	14	O	Clock output for external ROM (PCM2706C). Must be left open (PCM2707C).
D+	23	I/O	USB differential input/output plus <sup>(1)</sup>
D-	22	I/O	USB differential input/output minus <sup>(1)</sup>
DGND	20	—	Digital ground
DOUT	17	O	S/PDIF output/I <sup>2</sup> S data output
DT	15	I/O	Data input/output for external ROM (PCM2706C). Must be left open with pullup resistor (PCM2707C). <sup>(1)</sup>
FSEL	9	I	Function select (low: I <sup>2</sup> S data output, high: S/PDIF output) <sup>(2)</sup>
FUNC0	5	I/O	HID key state input (next track), active high (FSEL = 1). I <sup>2</sup> S LR clock output (FSEL = 0). <sup>(3)</sup>
FUNC1	19	I/O	HID key state input (previous track), active high (FSEL = 1). I <sup>2</sup> S bit clock output (FSEL = 0). <sup>(3)</sup>
FUNC2	18	I/O	HID key state input (stop), active high (FSEL = 1). I <sup>2</sup> S system clock output (FSEL = 0). <sup>(3)</sup>
FUNC3	4	I	HID key state input (play/pause), active high (FSEL = 1). I <sup>2</sup> S data input (FSEL = 0). <sup>(3)</sup>
HID0/MS	6	I	HID key state input (mute), active high (PCM2706C). MS input (PCM2707C). <sup>(3)</sup>
HID1/MC	7	I	HID key state input (volume up), active high (PCM2706C). MC input (PCM2707C). <sup>(3)</sup>
HID2/MD	8	I	HID key state input (volume down), active high (PCM2706C). MD input (PCM2707C). <sup>(3)</sup>
HOST	3	I	Host detection during self-powered operation (connect to V <sub>BUS</sub> ). Max power select during bus-powered operation. (low: 100 mA, high: 500 mA). <sup>(4)</sup>
PGND	1	—	Analog ground for DAC, OSC, and PLL
PSEL	16	I	Power source select (low: self-power, high: bus-power) <sup>(1)</sup>
SSPND	11	O	Suspend flag, active low (low: suspend, high: operational)
TEST	10	I	Test pin. Must be set high <sup>(1)</sup>

(1) LV-TTL level

(2) LV-TTL level.

(3) LV-TTL level with internal pulldown

(4) LV-TTL level, 5-V tolerant

**Pin Functions: PJT Package (PCM2706C/PCM2707C) (continued)**

PIN		I/O	DESCRIPTION
NAME	NO.		
V <sub>BUS</sub>	24	—	Connect to USB power (V <sub>BUS</sub> ) for bus-powered operation. Connect to V <sub>DD</sub> for self-powered operation.
V <sub>CCL</sub>	27	—	Analog power supply for headphone amplifier of L-channel <sup>(5)</sup>
V <sub>CCP</sub>	2	—	Analog power supply for DAC, OSC, and PLL <sup>(5)</sup>
V <sub>CCR</sub>	30	—	Analog power supply for headphone amplifier of R-channel <sup>(5)</sup>
V <sub>COM</sub>	32	—	Common voltage for DAC (V <sub>CCP</sub> /2). Connect decoupling capacitor to PGND.
V <sub>DD</sub>	21	—	Digital power supply <sup>(5)</sup>
V <sub>OUTL</sub>	28	O	DAC analog output for L-channel
V <sub>OUTR</sub>	29	O	DAC analog output for R-channel
XTI	12	I	Crystal oscillator input <sup>(1)</sup>
XTO	13	O	Crystal oscillator output
ZGND	25	—	Ground for internal regulator

(5) Connect decoupling capacitor to GND. Supply 3.3 V for self-powered applications.

## 7 Specifications

### 7.1 Absolute Maximum Ratings

Over operating free-air temperature range unless otherwise noted. <sup>(1)</sup>

		MIN	MAX	UNIT
Supply voltage	V <sub>BUS</sub>	−0.3	6.5	V
	V <sub>CCP</sub> , V <sub>CCL</sub> , V <sub>CCR</sub> , V <sub>DD</sub>	−0.3	4	V
Supply voltage differences	V <sub>CCP</sub> , V <sub>CCL</sub> , V <sub>CCR</sub> , V <sub>DD</sub>		±0.1	V
Ground voltage differences	PGND, AGNDL, AGNDR, DGND, ZGND		±0.1	V
Digital input voltage	HOST	−0.3	6.5	V
	D+, D−, HID0/MS, HID1/MC, HID2/MD, XTI, XTO, DOUT, SSPND, CK, DT, PSEL, FSEL, TEST, TEST0, TEST1, FUNC0, FUNC1, FUNC2, FUNC3	−0.3	(V <sub>DD</sub> + 0.3) < 4	V
Analog input voltage	V <sub>COM</sub>	−0.3	(V <sub>CCP</sub> + 0.3) < 4	V
	V <sub>OUTR</sub>	−0.3	(V <sub>CCR</sub> + 0.3) < 4	V
	V <sub>OUTL</sub>	−0.3	(V <sub>CCL</sub> + 0.3) < 4	V
Input current (any pins except supplies)		±10		mA
Ambient temperature under bias		−40	125	°C
Junction temperature			150	°C
Package temperature (IR reflow, peak)			260	°C
Storage temperature, T <sub>stg</sub>		−55	150	°C

(1) Stresses beyond those listed under *Absolute Maximum Ratings* may cause permanent damage to the device. These are stress ratings only, and functional operation of the device at these or any other conditions beyond those indicated under *Recommended Operating Conditions* is not implied. Exposure to absolute-maximum-rated conditions for extended periods may affect device reliability.

### 7.2 ESD Ratings

		MAX	UNIT
V <sub>(ESD)</sub>	Electrostatic discharge	Human body model (HBM), per ANSI/ESDA/JEDEC JS-001, all pins <sup>(1)</sup>	±3000
		Charged device model (CDM), per JEDEC specification JESD22-C101, all pins <sup>(2)</sup>	±1500

(1) JEDEC document JEP155 states that 500-V HBM allows safe manufacturing with a standard ESD control process.

(2) JEDEC document JEP157 states that 250-V CDM allows safe manufacturing with a standard ESD control process.

### 7.3 Recommended Operating Conditions

Over operating free-air temperature range.

		MIN	NOM	MAX	UNIT
Supply voltage	V <sub>BUS</sub>	4.35	5	5.25	V
	V <sub>CCP</sub> , V <sub>CCL</sub> , V <sub>CCR</sub> , V <sub>DD</sub>	3	3.3	3.6	
Digital input logic level		TTL-compatible			
Digital input clock frequency		11.994	12	12.006	MHz
Analog output load resistance		16	32		Ω
Analog output load capacitance				100	pF
Digital output load capacitance				20	pF
Operating free-air temperature, T <sub>A</sub>		-25		85	°C

### 7.4 Thermal Information: PCM2704C, PCM2705C

THERMAL METRIC <sup>(1)</sup>		PCM2704C, PCM2705C		UNIT
		DB (SSOP)		
		28 PINS		
R <sub>θJA</sub>	Junction-to-ambient thermal resistance	68.2		°C/W
R <sub>θJC(top)</sub>	Junction-to-case (top) thermal resistance	27.2		°C/W
R <sub>θJB</sub>	Junction-to-board thermal resistance	29.5		°C/W
ψ <sub>JT</sub>	Junction-to-top characterization parameter	2.7		°C/W
ψ <sub>JB</sub>	Junction-to-board characterization parameter	29.1		°C/W

(1) For more information about traditional and new thermal metrics, see the *Semiconductor and IC Package Thermal Metrics* application report, [SPRA953](#).

### 7.5 Thermal Information: PCM2706C, PCM2707C

THERMAL METRIC <sup>(1)</sup>		PCM2706C, PCM2707C		UNIT
		PJT (TQFP)		
		32 PINS		
R <sub>θJA</sub>	Junction-to-ambient thermal resistance	68.2		°C/W
R <sub>θJC(top)</sub>	Junction-to-case (top) thermal resistance	27.2		°C/W
R <sub>θJB</sub>	Junction-to-board thermal resistance	29.5		°C/W
ψ <sub>JT</sub>	Junction-to-top characterization parameter	2.7		°C/W
ψ <sub>JB</sub>	Junction-to-board characterization parameter	29.1		°C/W

(1) For more information about traditional and new thermal metrics, see the *Semiconductor and IC Package Thermal Metrics* application report, [SPRA953](#).

## 7.6 Electrical Characteristics: PCM2704CDB, PCM2705CDB, PCM2706CPJT, PCM2707CPJT

All specifications at  $T_A = 25^\circ\text{C}$ ,  $V_{\text{BUS}} = 5\text{ V}$ ,  $f_S = 44.1\text{ kHz}$ ,  $f_{\text{IN}} = 1\text{ kHz}$ , and 16-bit data (unless otherwise noted). For the Host interface, apply USB revision 1.1, full-speed. For audio data format, use USB isochronous data format.

PARAMETER		TEST CONDITIONS	MIN	TYP	MAX	UNIT
<b>INPUT LOGIC</b>						
$V_{\text{IH}}$	Input logic high level		2		3.3	$V_{\text{DC}}$
	Input logic high level <sup>(1)</sup>		2		5.5	
$V_{\text{IL}}$	Input logic low level		-0.3		0.8	$V_{\text{DC}}$
	Input logic low level <sup>(1)</sup>		-0.3		0.8	
$I_{\text{IH}}$	Input logic high current <sup>(2)</sup>	$V_{\text{IN}} = 3.3\text{ V}$			$\pm 10$	$\mu\text{A}$
	Input logic high current	$V_{\text{IN}} = 3.3\text{ V}$		65	100	
$I_{\text{IL}}$	Input logic low current <sup>(2)</sup>	$V_{\text{IN}} = 0\text{ V}$			$\pm 10$	$\mu\text{A}$
	Input logic low current	$V_{\text{IN}} = 0\text{ V}$			$\pm 10$	
<b>OUTPUT LOGIC</b>						
$V_{\text{OH}}$	Output logic high level <sup>(3)</sup>	$I_{\text{OH}} = -2\text{ mA}$	2.8			$V_{\text{DC}}$
	Output logic high level	$I_{\text{OH}} = -2\text{ mA}$	2.4			
$V_{\text{OL}}$	Output logic low level <sup>(3)</sup>	$I_{\text{OL}} = 2\text{ mA}$			0.3	$V_{\text{DC}}$
	Output logic low level	$I_{\text{OL}} = 2\text{ mA}$			0.4	
<b>CLOCK FREQUENCY</b>						
	Input clock frequency, XTI		11.994	12	12.006	MHz
$f_S$	Sampling frequency			32 44.1 48		kHz
<b>DAC CHARACTERISTICS</b>						
	Resolution			16		bits
	Audio data channel			1, 2		channel
<b>DC ACCURACY</b>						
	Gain mismatch, channel-to-channel			$\pm 2$	$\pm 8$	% of FSR
	Gain error			$\pm 2$	$\pm 8$	% of FSR
	Bipolar zero error			$\pm 3$	$\pm 6$	% of FSR
<b>DYNAMIC PERFORMANCE <sup>(4)</sup></b>						
THD + N	Total harmonic distortion + noise	Line <sup>(5)</sup>	$R_L > 10\text{ k}\Omega$ , self-powered, $V_{\text{OUT}} = 0\text{ dB}$	0.006%	0.01%	
			$R_L > 10\text{ k}\Omega$ , bus-powered, $V_{\text{OUT}} = 0\text{ dB}$	0.012%	0.02%	
		Headphone	$R_L = 32\ \Omega$ , self- or bus-powered, $V_{\text{OUT}} = 0\text{ dB}$	0.025%		
THD + N	Total harmonic distortion + noise	$V_{\text{OUT}} = -60\text{ dB}$		2%		
	Dynamic range	EIAJ, A-weighted	90	98		dB
SNR	Signal-to-noise ratio	EIAJ, A-weighted	90	98		dB
	Channel separation		60	70		dB

(1) HOST pin.

(2) D+, D-, HOST, TEST, TEST0, TEST1, DT, PSEL, FSEL, XTI pins.

(3) FUNC0, FUNC1, and FUNC2 pins.

(4)  $f_{\text{IN}} = 1\text{ kHz}$ , using the System Two Cascade™ audio measurement system by Audio Precision® in RMS mode with a 20-kHz low-pass filter (LPF) and 400-Hz high-pass filter (HPF).

(5) THD + N performance varies slightly, depending on the effective output load, including dummy load R7 and R8 in [Figure 35](#).

**Electrical Characteristics: PCM2704CDB, PCM2705CDB, PCM2706CPJT, PCM2707CPJT (continued)**

All specifications at  $T_A = 25^\circ\text{C}$ ,  $V_{\text{BUS}} = 5\text{ V}$ ,  $f_S = 44.1\text{ kHz}$ ,  $f_{\text{IN}} = 1\text{ kHz}$ , and 16-bit data (unless otherwise noted). For the Host interface, apply USB revision 1.1, full-speed. For audio data format, use USB isochronous data format.

PARAMETER		TEST CONDITIONS	MIN	TYP	MAX	UNIT
<b>ANALOG OUTPUT</b>						
Output voltage			0.55 $V_{\text{CCL}}$ 0.55 $V_{\text{CCR}}$			$V_{\text{PP}}$
Center voltage			0.5 $V_{\text{CCP}}$			V
Load impedance	Line	AC-coupling	10			k $\Omega$
	Headphone	AC-coupling	16	32		$\Omega$
LPF frequency response		-3 dB		140		kHz
		$f = 20\text{ kHz}$		-0.1		dB
<b>DIGITAL FILTER PERFORMANCE</b>						
Passband					0.454 $f_S$	Hz
Stop band			0.546 $f_S$			Hz
Passband ripple					$\pm 0.04$	dB
Stop band attenuation			-50			dB
Delay time				20 / $f_S$		s
<b>POWER SUPPLY REQUIREMENTS</b>						
Voltage range	$V_{\text{BUS}}$	Bus-powered	4.35	5	5.25	$V_{\text{DC}}$
	$V_{\text{CCP}}, V_{\text{CCL}}, V_{\text{CCR}}, V_{\text{DD}}$	Self-powered	3	3.3	3.6	
Supply current	Line	DAC operation		23	30	mA
	Headphone	DAC operation ( $R_L = 32\ \Omega$ )		35	46	
	Line/headphone	Suspend mode <sup>(6)</sup>		150	190	$\mu\text{A}$
Power dissipation (self-powered)	Line	DAC operation		76	108	mW
	Headphone	DAC operation ( $R_L = 32\ \Omega$ )		116	166	
	Line/headphone	Suspend mode <sup>(6)</sup>		495	684	$\mu\text{W}$
Power dissipation (bus-powered)	Line	DAC operation		115	158	mW
	Headphone	DAC operation ( $R_L = 32\ \Omega$ )		175	242	
	Line/headphone	Suspend mode <sup>(6)</sup>		750	998	$\mu\text{W}$
Internal power-supply voltage <sup>(7)</sup>	$V_{\text{CCP}}, V_{\text{CCL}}, V_{\text{CCR}}, V_{\text{DD}}$	Bus-powered	3.2	3.35	3.5	$V_{\text{DC}}$
<b>TEMPERATURE RANGE</b>						
Operating temperature			-25		85	$^\circ\text{C}$

(6) In USB suspended state

(7)  $V_{\text{DD}}, V_{\text{CCP}}, V_{\text{CCL}}, V_{\text{CCR}}$  pins. These pins work as output pins of internal power supply for bus-powered operation.

## 7.7 Audio Interface Timing Characteristics

Load capacitance of LRCK, BCK, and DOUT is 20 pF. For timing diagrams, see [Figure 1](#) and [Figure 2](#).

		MIN	MAX	UNIT
$t_{(BCY)}$	BCK pulse cycle time	300		ns
$t_{(BCH)}$	BCK pulse duration, high	100		ns
$t_{(BCL)}$	BCK pulse duration, low	100		ns
$t_{(BL)}$	LRCK delay time from BCK falling edge	-20	40	ns
$t_{(BD)}$	DOUT delay time from BCK falling edge	-20	40	ns
$t_{(LD)}$	DOUT delay time from LRCK edge	-20	40	ns
$t_{(DS)}$	DIN setup time	20		ns
$t_{(DH)}$	DIN hold time	20		ns

## 7.8 Audio Clock Timing Characteristics

Load capacitance is 20 pF. For timing diagrams, see [Figure 3](#).

		MIN	MAX	UNIT
$t_{(SLL)}, t_{(SLH)}$	LRCK delay time from SYSCK rising edge	-5	10	ns
$t_{(SBL)}, t_{(SBH)}$	BCK delay time from SYSCK rising edge	-5	10	ns

## 7.9 External ROM Read Interface Timing Characteristics

For timing diagrams, see [Figure 4](#).

		MIN	MAX	UNIT
$f_{(CK)}$	CK clock frequency		100	kHz
$t_{(BUF)}$	Bus free time between a STOP and a START condition	4.7		$\mu$ s
$t_{(LOW)}$	Low period of the CK clock	4.7		$\mu$ s
$t_{(HI)}$	High period of the CK clock	4		$\mu$ s
$t_{(RS-SU)}$	Setup time for START/repeated START condition	4.7		$\mu$ s
$t_{(S-HD)}$ $t_{(RS-HD)}$	Hold time for START/repeated START condition	4		$\mu$ s
$t_{(D-SU)}$	Data setup time	250		ns
$t_{(D-HD)}$	Data hold time	0	900	ns
$t_{(CK-R)}$	Rise time of CK signal	$20 + 0.1 C_B$	1000	ns
$t_{(CK-F)}$	Fall time of CK signal	$20 + 0.1 C_B$	1000	ns
$t_{(DT-R)}$	Rise time of DT signal	$20 + 0.1 C_B$	1000	ns
$t_{(DT-F)}$	Fall time of DT signal	$20 + 0.1 C_B$	1000	ns
$t_{(P-SU)}$	Setup time for STOP condition	4		$\mu$ s
$C_B$	Capacitive load for DT and CK lines		400	pF
$V_{NH}$	Noise margin at high level for each connected device (including hysteresis)	$0.2 V_{DD}$		V

### 7.10 SPI Timing Characteristics

For timing diagrams, see [Figure 5](#).

		MIN	MAX	UNIT
$t_{(MCY)}$	MC pulse cycle time	100		ns
$t_{(MCL)}$	MC low-level time	50		ns
$t_{(MCH)}$	MC high-level time	50		ns
$t_{(MHH)}$	MS high-level time	100		ns
$t_{(MLS)}$	MS falling edge to MC rising edge	20		ns
$t_{(MLH)}$	MS hold time	20		ns
$t_{(MDH)}$	MD hold time	15		ns
$t_{(MDS)}$	MD setup time	20		ns

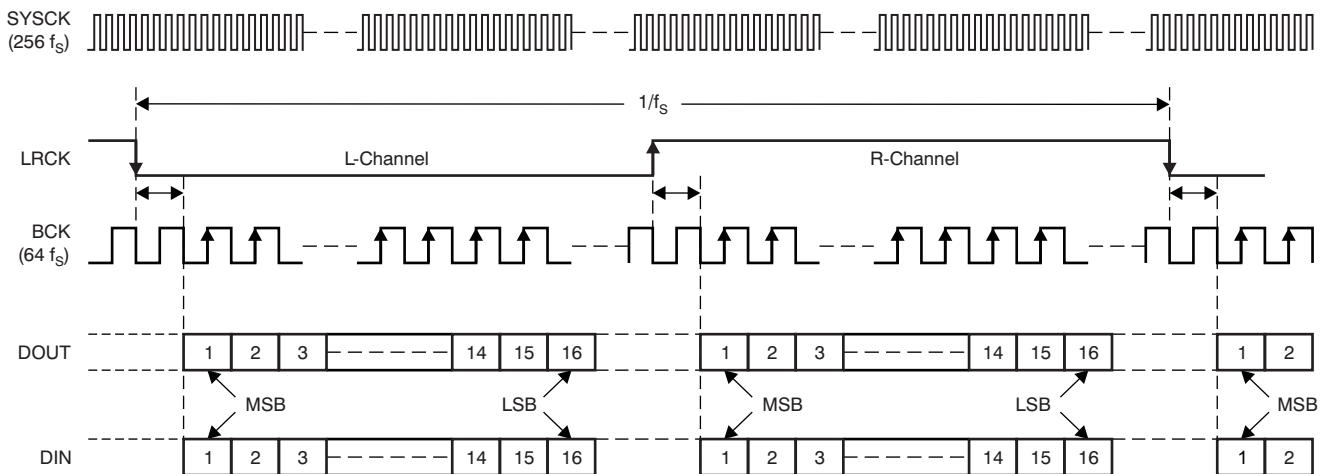

Figure 1. Audio Data Interface Format

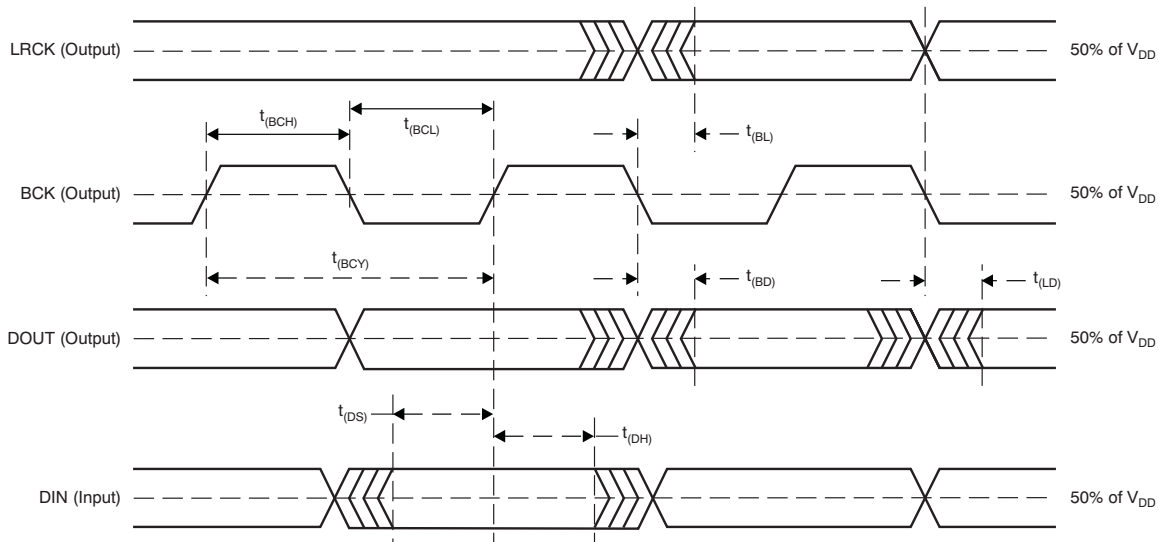

Figure 2. Audio Interface Timing

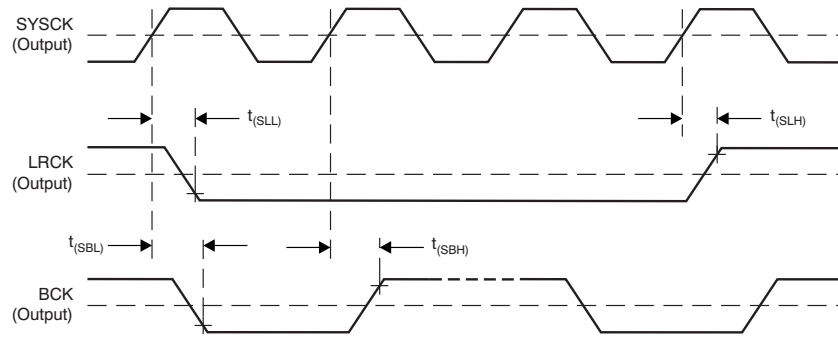

Figure 3. Audio Clock Timing

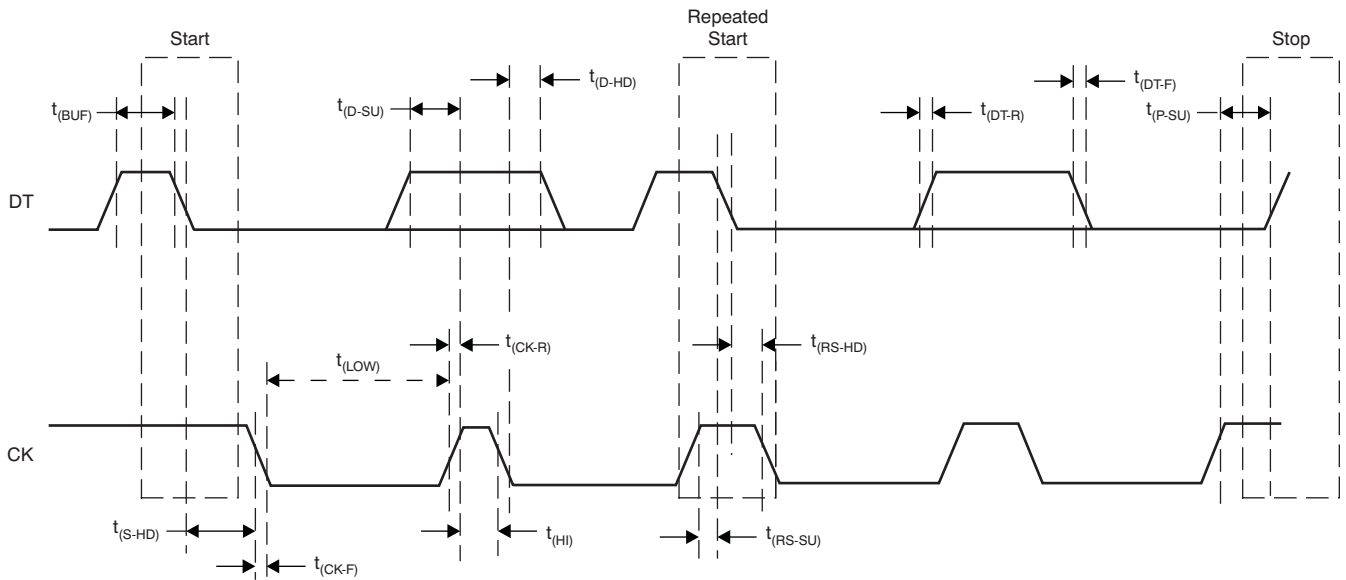

Figure 4. External ROM Read Interface Timing Requirements

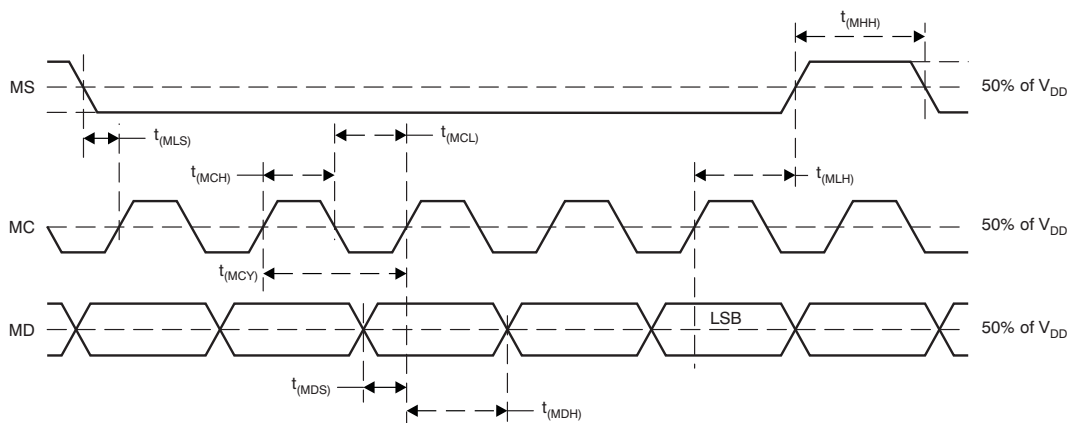
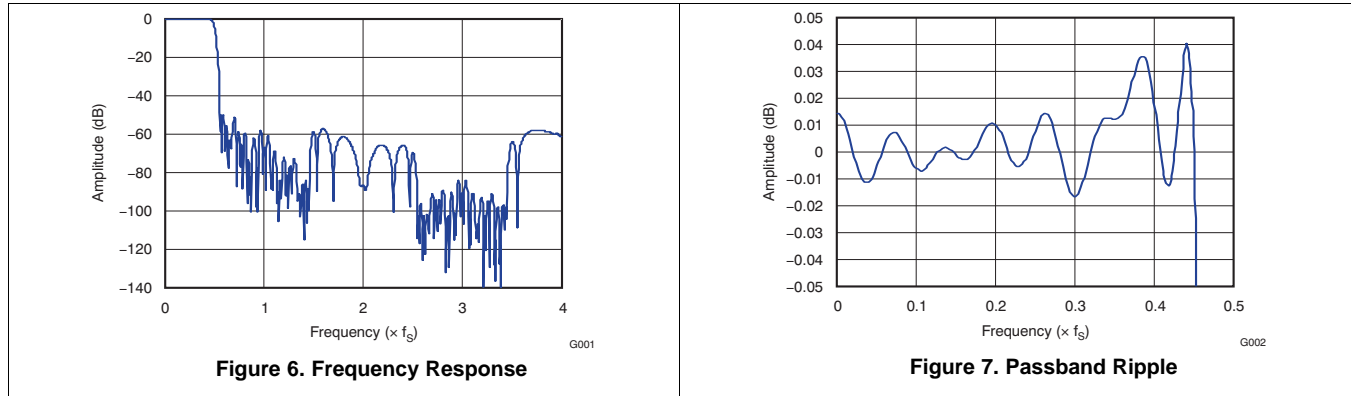

Figure 5. SPI Timing Diagram

## 7.11 Typical Characteristics

### 7.11.1 Internal Filter: DAC Digital Interpolation Filter Frequency Response

All specifications at  $T_A = 25^\circ\text{C}$ ,  $V_{\text{BUS}} = 5\text{ V}$ ,  $f_S = 44.1\text{ kHz}$ ,  $f_{\text{IN}} = 1\text{ kHz}$ , 16-bit data (unless otherwise noted).



### 7.11.2 Internal Filter: DAC Analog Low-Pass Filter Frequency Response

All specifications at  $T_A = 25^\circ\text{C}$ ,  $V_{\text{BUS}} = 5\text{ V}$ ,  $f_S = 44.1\text{ kHz}$ ,  $f_{\text{IN}} = 1\text{ kHz}$ , 16-bit data (unless otherwise noted).

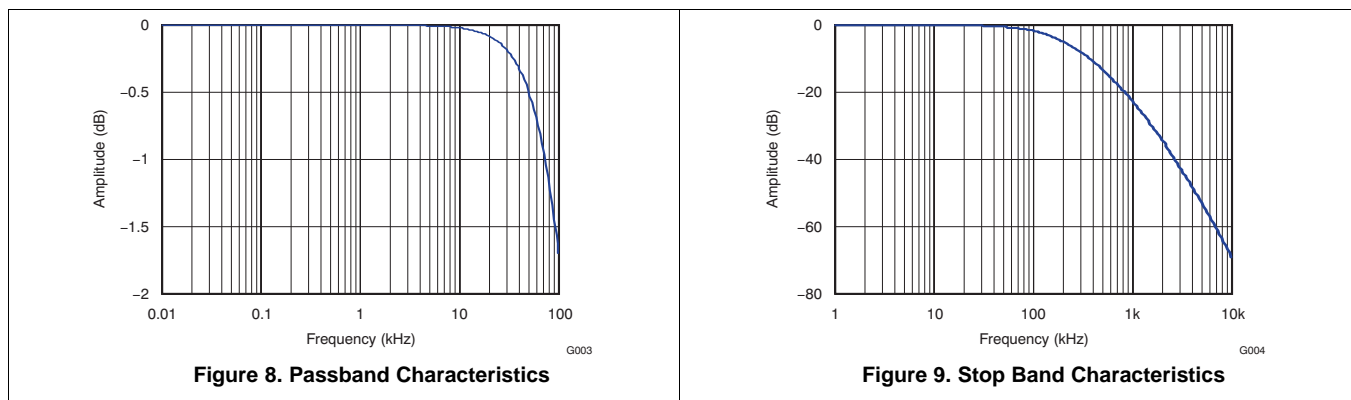

### 7.11.3 General Characteristics

All specifications at  $T_A = 25^\circ\text{C}$ ,  $V_{\text{BUS}} = 5\text{ V}$ ,  $f_S = 44.1\text{ kHz}$ ,  $f_{\text{IN}} = 1\text{ kHz}$ , 16-bit data (unless otherwise noted).

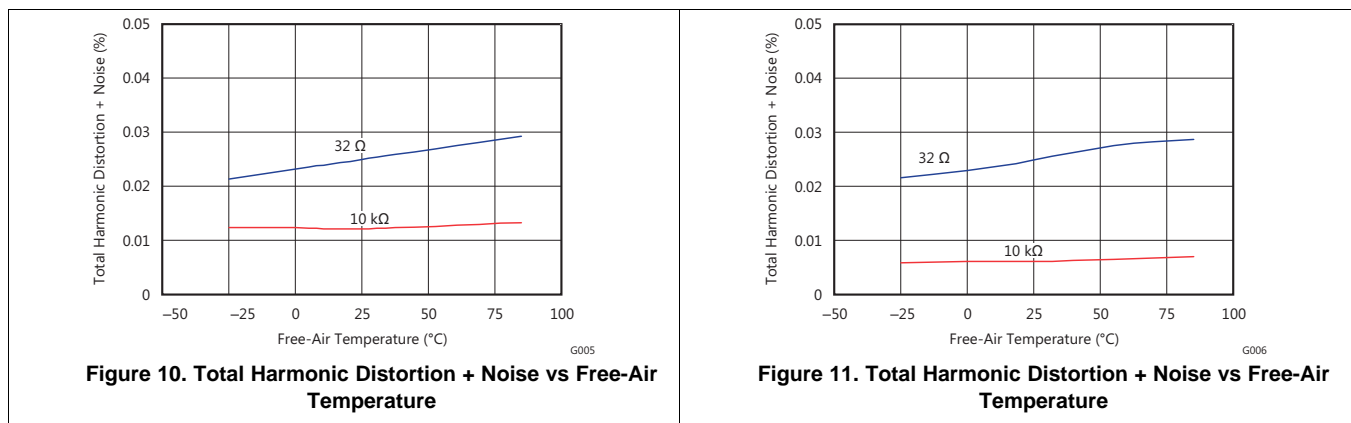

General Characteristics (continued)

All specifications at  $T_A = 25^\circ\text{C}$ ,  $V_{\text{BUS}} = 5\text{ V}$ ,  $f_S = 44.1\text{ kHz}$ ,  $f_{\text{IN}} = 1\text{ kHz}$ , 16-bit data (unless otherwise noted).

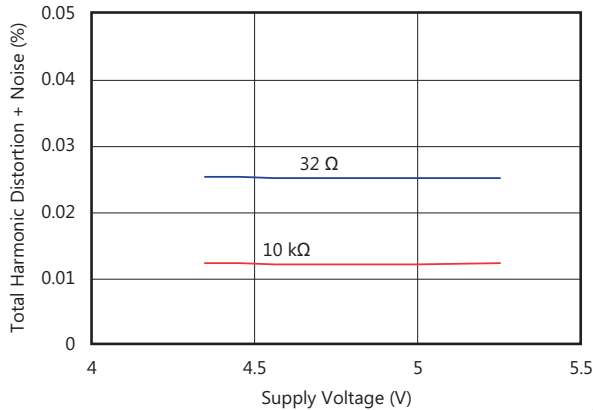

Figure 12. Total Harmonic Distortion + Noise vs Supply Voltage

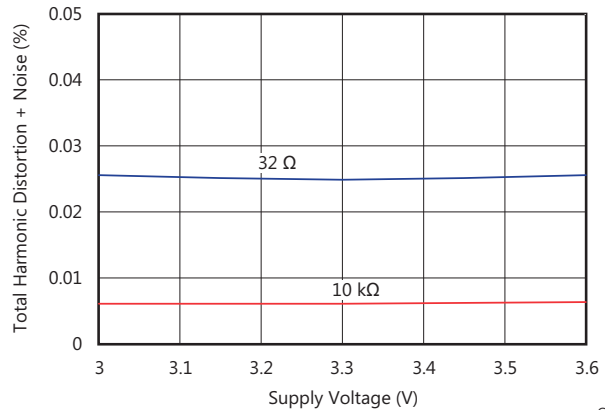

Figure 13. Total Harmonic Distortion + Noise vs Supply Voltage

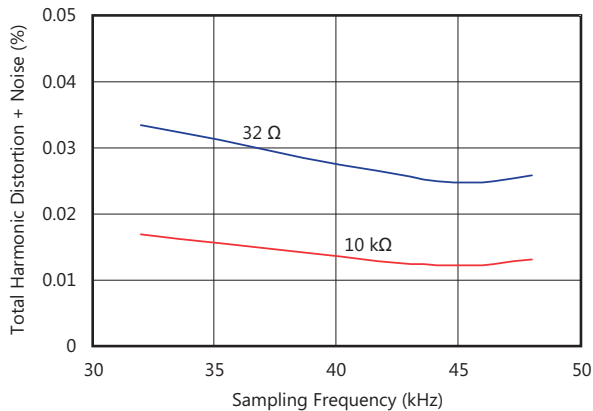

Figure 14. Total Harmonic Distortion + Noise vs Sampling Frequency

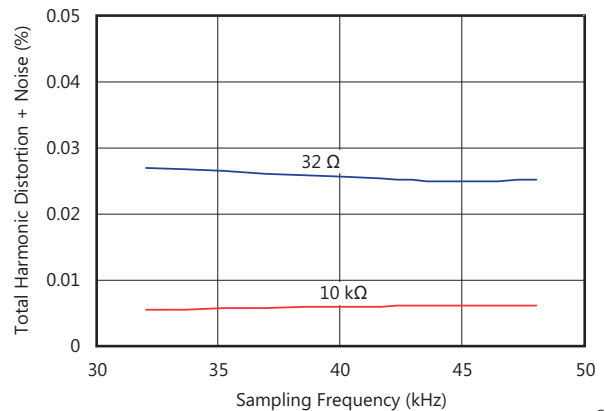

Figure 15. Total Harmonic Distortion + Noise vs Sampling Frequency

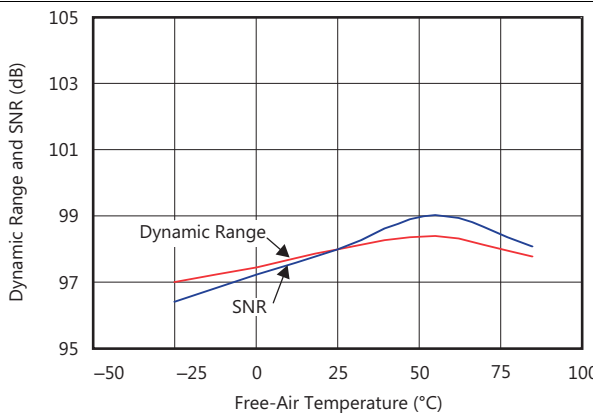

Figure 16. Dynamic Range and SNR vs Free-Air Temperature

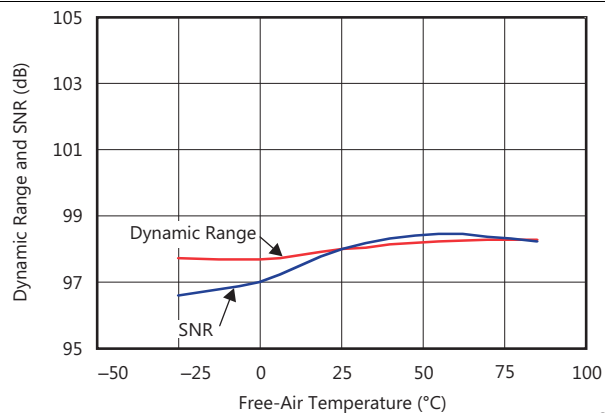

Figure 17. Dynamic Range and SNR vs Free-Air Temperature

### General Characteristics (continued)

All specifications at  $T_A = 25^\circ\text{C}$ ,  $V_{\text{BUS}} = 5\text{ V}$ ,  $f_S = 44.1\text{ kHz}$ ,  $f_{\text{IN}} = 1\text{ kHz}$ , 16-bit data (unless otherwise noted).

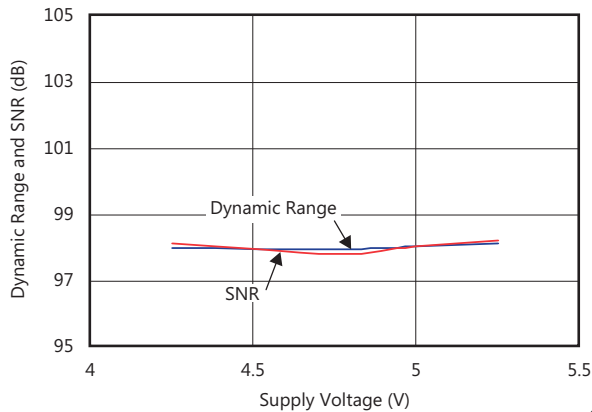

Figure 18. Dynamic Range and SNR vs Supply Voltage

G013

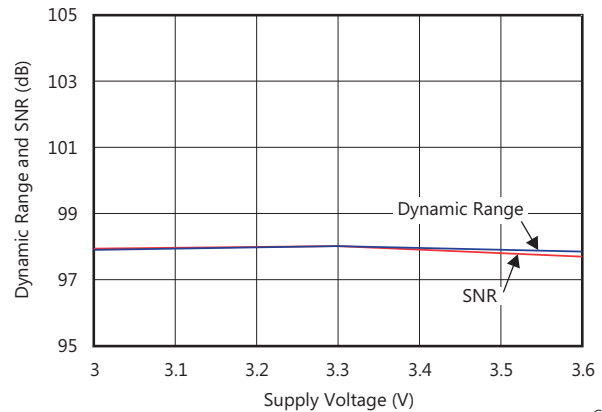

Figure 19. Dynamic Range and SNR vs Supply Voltage

G014

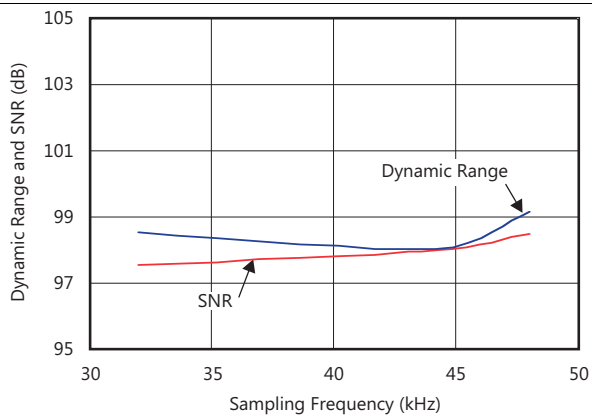

Figure 20. Dynamic Range and SNR vs Sampling Frequency

G015

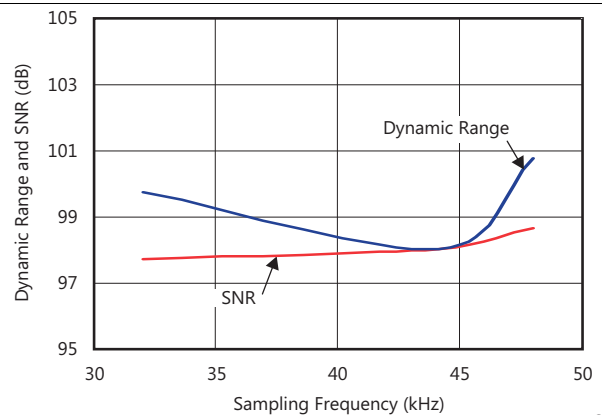

Figure 21. Dynamic Range and SNR vs Sampling Frequency

G016

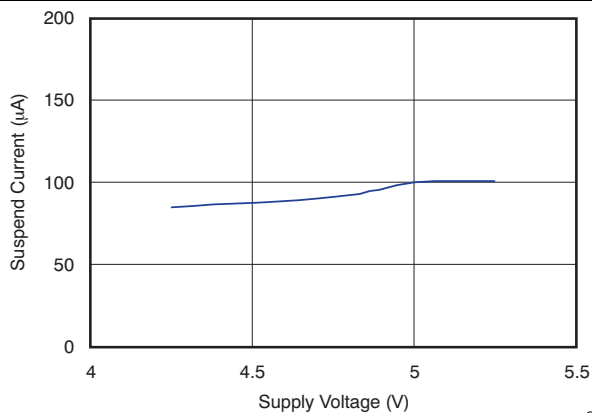

Figure 22. Suspend Current vs Supply Voltage

G017

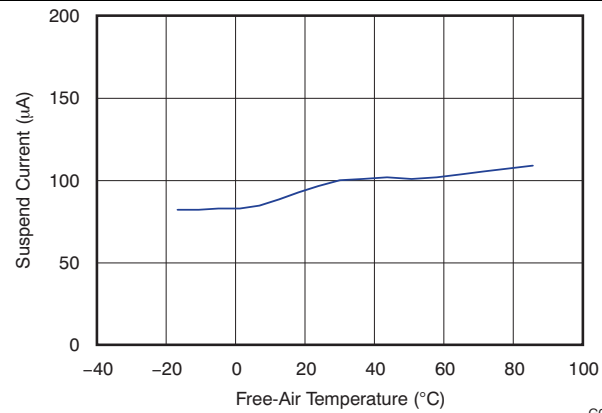
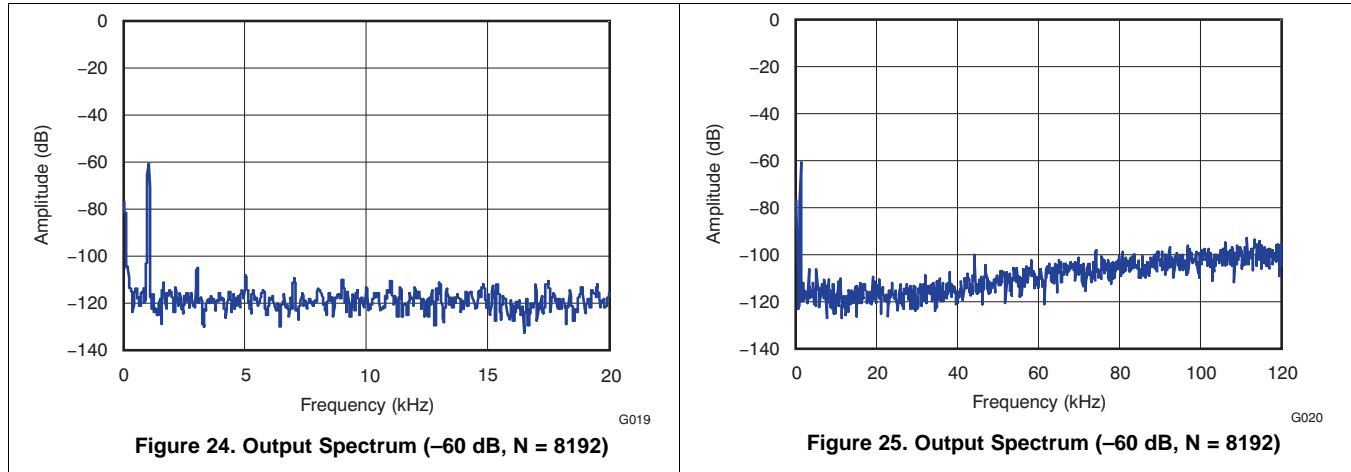

Figure 23. Suspend Current vs Free-Air Temperature

G018

**General Characteristics (continued)**

All specifications at  $T_A = 25^\circ\text{C}$ ,  $V_{\text{BUS}} = 5\text{ V}$ ,  $f_S = 44.1\text{ kHz}$ ,  $f_{\text{IN}} = 1\text{ kHz}$ , 16-bit data (unless otherwise noted).



**8 Parameter Measurement Information**

All parameters are measured according to the conditions described in [Specifications](#).

## 9 Detailed Description

### 9.1 Overview

The PCM2704C/5C/6C/7C is a stereo audio digital-to-analog converter (DAC) with USB connection capability and a S/PDIF digital interface.

The PCM2704C/5C/6C/7C can be used in self-powered and bus-powered modes. These devices meet the requirements of USB2.0 standard connection. The PCM2704C/5C/6C/7C has digital input from the USB port. The PCM2704C/5C provides two different paths for the audio data, one of which goes to the digital S/PDIF output, and the other to the analog output through the DAC. The PCM2706C/7C provides three different paths for the audio data; to the digital S/PDIF output, to the analog output through the DAC, and leading the audio data to the I2S digital output (the I2S path is selectable through FSEL pin 9).

The PCM2704C has 3 external interrupts (HID) which control the Mute, Volume Up, and Volume Down; these control inputs are active High. The PCM2706C has 7 external interrupts (I2S/HID control is selectable through FSEL pin 9) which control the Mute, Volume Up, Volume Down, Next track, Previous track, Play/Pause, and Stop; these control inputs are active High. The PCM2704C/5C/6C/7C requires a 12-MHz clock, which can be provided by an external clock or generated by a built-in crystal resonator.

### 9.2 Functional Block Diagrams

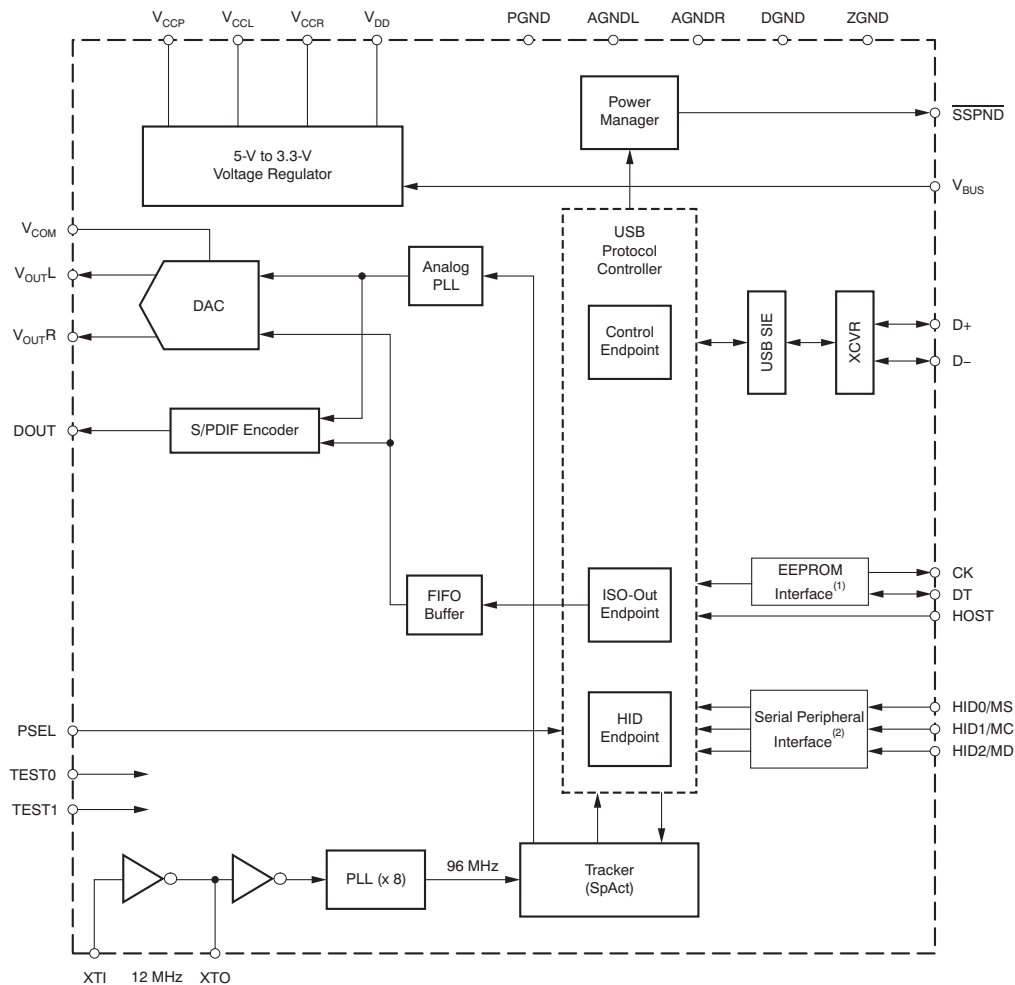

(1) Applies to PCM2704CDB

(2) Applies to PCM2705CDB

**Figure 26. PCM2704C/PCM2705C**



## 9.3 Feature Description

### 9.3.1 Clock and Reset

For both USB and audio functions, the PCM2704C/5C/6C/7C require a 12-MHz ( $\pm 500$  ppm) clock that can be generated by the onboard oscillator using a 12-MHz crystal resonator. The 12-MHz crystal resonator must be connected to the XTI pin (pin 28 for the PCM2704C/5C, pin 12 for the PCM2706C/7C) and the XTO pin (pin 1 for the PCM2704C/5C, pin 13 for the PCM2706C/7C) with one large (1-M $\Omega$ ) resistor and two small capacitors; the capacitance of these components depends on the specified load capacitance of the crystal resonator. An external clock can be supplied from XTI (pin 28 for the PCM2704C/5C, pin 12 for the PCM2706C/7C). If an external clock is supplied, XTO (pin 1 for the PCM2704C/5C, pin 13 for the PCM2706C/7C) must be left open. No clock disabling pin is provided; therefore, TI does not recommend to use the external clock supply. SSPND (pin 27 for the PCM2704C/5C, pin 11 for the PCM2706C/7C) cannot use clock disabling.

The PCM2704C/5C/6C/7C have an internal power-on reset circuit, which works automatically when  $V_{DD}$  (pin 7 for the PCM2704C/5C, pin 21 for the PCM2706C/7C) exceeds 2-V typical (1.6 to 2.4 V), which is equivalent to  $V_{BUS}$  (pin 10 for the PCM2704C/5C, pin 24 for the PCM2706C/7C) exceeding 3-V typical for bus-powered applications. Approximately 700  $\mu$ s is required until an internal reset release occurs.

### 9.3.2 Operation Mode Selection

The PCM2704C/5C/6C/7C have the following mode-select pins.

#### 9.3.2.1 Power Configuration Select/Host Detection

PSEL (pin 4 for the PCM2704C/5C, pin 16 for the PCM2706C/7C) is dedicated to selecting the power source. This selection affects the configuration descriptor. While in bus-powered operation, the maximum power consumption from  $V_{BUS}$  is determined by the HOST pin (pin 21 for the PCM2704C/5C, pin 3 for the PCM2706C/7C). For self-powered operation, the HOST pin must be connected to  $V_{BUS}$  of the USB bus with a pulldown resistor to detect attach and detach. (To avoid excessive suspend current, the pulldown should be a high-value resistor.) [Table 1](#) summarizes the power configuration select options.

**Table 1. Power Configuration Select**

PSEL	DESCRIPTION
0	Self-powered
1	Bus-powered
HOST	DESCRIPTION
0	Detached from USB (self-powered)/100 mA (bus-powered)
1	Attached to USB (self-powered)/500 mA (bus-powered)

#### 9.3.2.2 Function Select (PCM2706C/7C Only)

FSEL (pin 9) determines the function of the FUNC0 through FUNC3 pins (pins 4, 5, 18, and 19) and DOUT (pin 17). When the I<sup>2</sup>S interface is required, FSEL must be low. Otherwise, FSEL must be high. [Table 2](#) lists the functionality of the FUNC0 through FUNC3 pins, based on the FSEL pin.

**Table 2. Function Select**

FSEL	DOUT	FUNC0	FUNC1	FUNC2	FUNC3
0	Data out (I <sup>2</sup> S)	LRCK (I <sup>2</sup> S)	BCK (I <sup>2</sup> S)	SYSCK (I <sup>2</sup> S)	Data in (I <sup>2</sup> S)
1	S/PDIF data	Next track (HID) <sup>(1)</sup>	Previous track (HID) <sup>(1)</sup>	Stop (HID) <sup>(1)</sup>	Play/pause (HID) <sup>(1)</sup>

(1) Valid on the PCM2706C only; no function assigned on the PCM2707C.

### 9.3.3 DAC

The PCM2704C/5C/6C/7C have a DAC that uses an oversampling technique with  $128\text{-}f_s$ , second-order, multi-bit noise shaping. This technique provides extremely-low quantization noise in the audio band, and the built-in analog low-pass filter removes the high-frequency components of the noise-shaping signal. The DAC analog outputs,  $V_{OUTL}$  and  $V_{OUTR}$ , are sent through the headphone amplifier and can provide 12 mW at 32  $\Omega$  as well as 1.8  $V_{PP}$  into a 10-k $\Omega$  load.

### 9.3.4 Digital Audio Interface: S/PDIF Output

The PCM2704C/5C/6C/7C employ S/PDIF output. Isochronous-out data from the host are encoded to S/PDIF output DOUT, as well as to DAC analog outputs  $V_{OUTL}$  and  $V_{OUTR}$ . The interface format and timing follow the IEC-60958 standard. Monaural data are converted to the stereo format at the same data rate. S/PDIF output is not supported in the I<sup>2</sup>S I/F enable mode. The implementation of this feature is optional.

#### NOTE

It is the responsibility of the user to determine whether or not to implement this feature in the end application.

#### 9.3.4.1 Channel Status Information

Channel status information is fixed, and includes consumer application, PCM mode, copyright, and digital/digital converter data. All other bits are fixed as 0s, except for the sample frequency, which is set automatically according to the data received through the USB.

#### 9.3.4.2 Copyright Management

Digital audio data output is always encoded as original with SCMS control. Only one generation of digital duplication is allowed.

### 9.3.5 Digital Audio Interface: I<sup>2</sup>S Interface Output (PCM2706C/7C)

The PCM2706C and PCM2707C can support the I<sup>2</sup>S interface, which is enabled by the FSEL pin (pin 9). In the I<sup>2</sup>S interface-enabled mode, pins 4, 18, 19, 5, and 17 are assigned as DIN, SYSCK, BCK, LRCK, and DOUT, respectively. These pins provide digital output/input data in the 16-bit I<sup>2</sup>S format, which is also accepted by the internal DAC. [Figure 1](#), [Figure 2](#), and [Figure 3](#) show the I<sup>2</sup>S interface format and timing. [Audio Interface Timing Characteristics](#) and [Audio Clock Timing Characteristics](#) list the audio interface timing and audio clock timing characteristics, respectively.

### 9.3.6 Descriptor Data Modification

The descriptor data can be modified through the I<sup>2</sup>C port by external ROM (PCM2704C/6C) or through the SPI port by an SPI host such as an MCU (PCM2705C/7C) under a particular configuration of the PSEL and HOST pins. Setting both the PSEL and the HOST pins high is necessary to modify the descriptor data; the D+ pin pullup resistor must not be activated before programming the descriptor data through the external ROM or SPI port is completed. The descriptor data must be sent from an external ROM to the PCM2704C/6C or from the SPI host to the PCM2705C/7C in LSB first format, with a specified byte order. Additionally, the power attribute and max power contents must be consistent with the PSEL setting and the power usage from the USB  $V_{BUS}$  of the end application. Therefore, the device does not support descriptor data modification in self-powered configuration (PSEL = low).

### 9.3.7 External ROM Descriptor (PCM2704C/6C)

The PCM2704C/6C support an external ROM interface to override internal descriptors. Pin 3 (for the PCM2704C) or pin 15 (for the PCM2706C) is assigned as DT (serial data), and pin 2 (for the PCM2704C) or pin 14 (for the PCM2706C) is assigned as CK (serial clock) of the I<sup>2</sup>C interface when using the external ROM descriptor. Descriptor data are transferred from the external ROM to the PCM2704C/6C through the I<sup>2</sup>C interface the first time when the device is activated after a power-on reset. Before completing a read of the external ROM, the PCM2704C/6C reply with *NACK* for any USB command request from the host to the device itself. The descriptor data, which can be in the external ROM, must meet these parameters:

- String descriptors must be described in ANSI ASCII code (1 byte for each character).
- String descriptors are converted automatically to unicode strings for transmission to the host.
- The device address of the external ROM is fixed as 0xA0.

The data bits must be sent from LSB to MSB on the I<sup>2</sup>C bus. This condition means that each byte of data must be stored with its bits in reverse order. A read operation is performed at a frequency of XTI/384 (approximately 30 kHz). The power attribute and max power contents must be consistent with the end application circuit configuration (the PSEL setting and the actual power usage from  $V_{BUS}$  of the USB connector); otherwise, it may cause improper or unexpected PCM2704C/6C operation.

The data must be stored from address 0x00 and must consist of 57 bytes, according to these listed parameters:

- Vendor ID (2 bytes)
- Product ID (2 bytes)
- Product string (16 bytes in ANSI ASCII code)
- Vendor string (32 bytes in ANSI ASCII code)
- Power attribute (1 byte)
- Max power (1 byte)
- Auxiliary HID usage ID in report descriptor (3 bytes)

Figure 28 shows the timing for an external ROM read operation. Table 3 summarizes the timing characteristics.

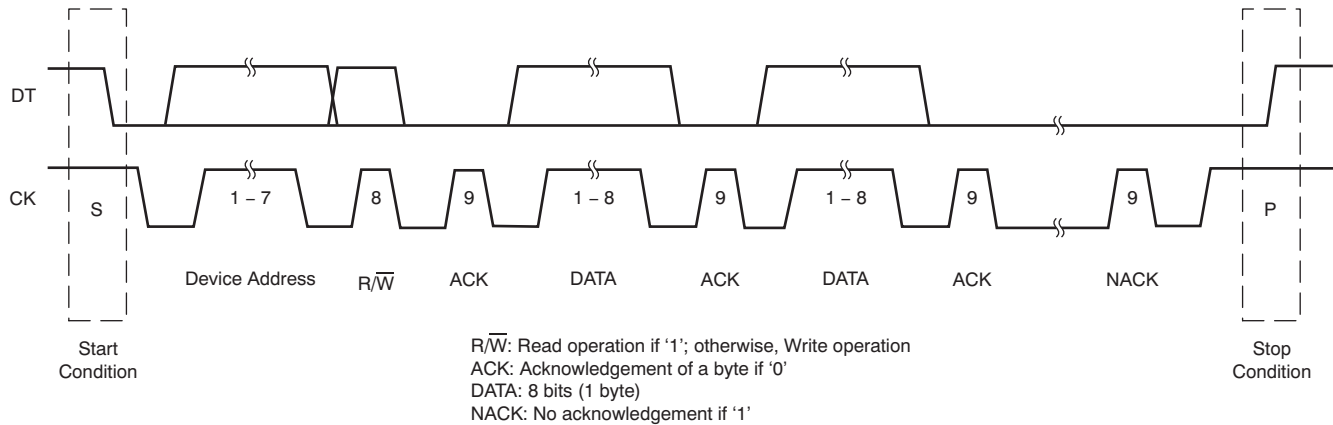

**Figure 28. External ROM Read Operation**

**Table 3. External ROM Read Operation Characteristics**

M	M	M	S	S	M	S	M	S	M	M
S	Device address	$R/\overline{W}$	ACK	DATA	ACK	DATA	ACK	...	NACK	P

### 9.3.8 External ROM Example

#### External ROM data (sample set)

```

0xBB, 0x08, 0x04, 0x27,
0x50, 0x72, 0x6F, 0x64, 0x75, 0x63, 0x74, 0x20, 0x73, 0x74, 0x72, 0x69, 0x6E, 0x67, 0x73, 0x2E,
0x56, 0x65, 0x6E, 0x64, 0x6F, 0x72, 0x20, 0x73, 0x74, 0x72, 0x69, 0x6E, 0x67, 0x73, 0x20, 0x61,
0x72, 0x65, 0x20, 0x70, 0x6C, 0x61, 0x63, 0x65, 0x64, 0x20, 0x68, 0x65, 0x72, 0x65, 0x2E, 0x20,
0x80,
0x7D,
0x0A, 0x93, 0x01
    
```

#### Explanation

Data are stored beginning at address 0x00

**Vendor ID:** 0x08BB

**Product ID:** 0x2704

**Product string:** Product strings (16 bytes)

**Vendor string:** Vendor strings are placed here (32 bytes, 31 visible characters are followed by 1 space).

**Power attribute (bmAttribute):** 0x80 (bus-powered)

**Max power (maxPower):** 0x7D (250 mA)

**Auxiliary HID usage ID:** 0x0A, 0x93, 0x01 (AL A/V capture)

Note that the data bits must be sent from LSB to MSB on the I<sup>2</sup>C bus. Therefore, each data byte must be stored with its bits in reverse order.

### 9.3.9 Serial Programming Interface (PCM2705C/7C)

The PCM2705C/7C supports a SPI to program the descriptor and to set the HID state. [External ROM Descriptor \(PCM2704C/6C\)](#) describes descriptor data. [Figure 5](#) shows the SPI timing; [SPI Timing Characteristics](#) lists the respective timing characteristics.

[Figure 29](#) shows the SPI write timing sequence.

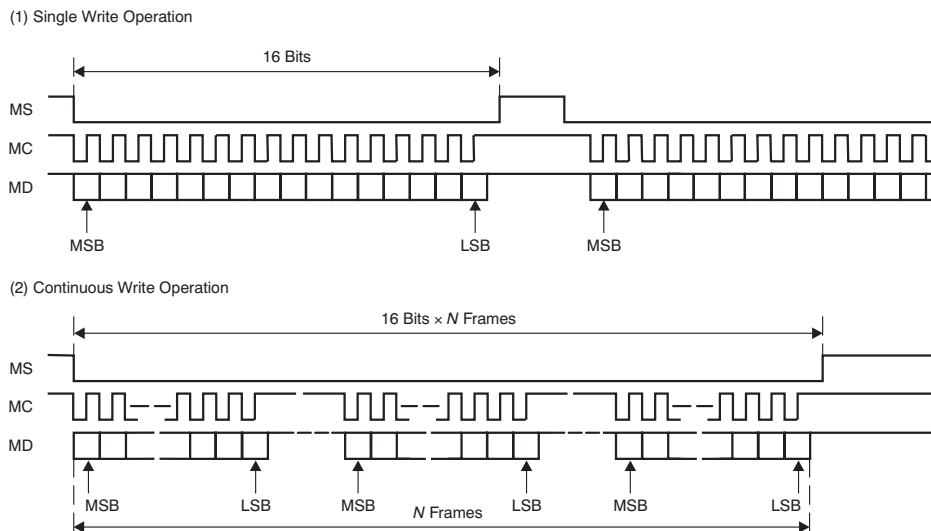

Figure 29. SPI Write Operation

### 9.3.10 USB Host Interface Sequence

#### 9.3.10.1 Power-On, Attach, and Playback Sequence

The PCM2704C/5C/6C/7C are ready for setup when the reset sequence has finished and the USB bus is attached. After a connection has been established (through the setup process), the PCM2704C/5C/6C/7C are ready to accept USB audio data. While waiting for the audio data (that is, the device is in an idle state), the analog output is set to bipolar zero (BPZ).

Upon receiving the audio data, the PCM2704C/5C/6C/7C stores the first audio packet in the internal storage buffer. The packet contains 1 ms of audio data. The PCM2704C/5C/6C/7C start playing the audio data after detecting the next subsequent start-of-frame (SOF) packet. Figure 30 shows the initial operation sequence for the device.

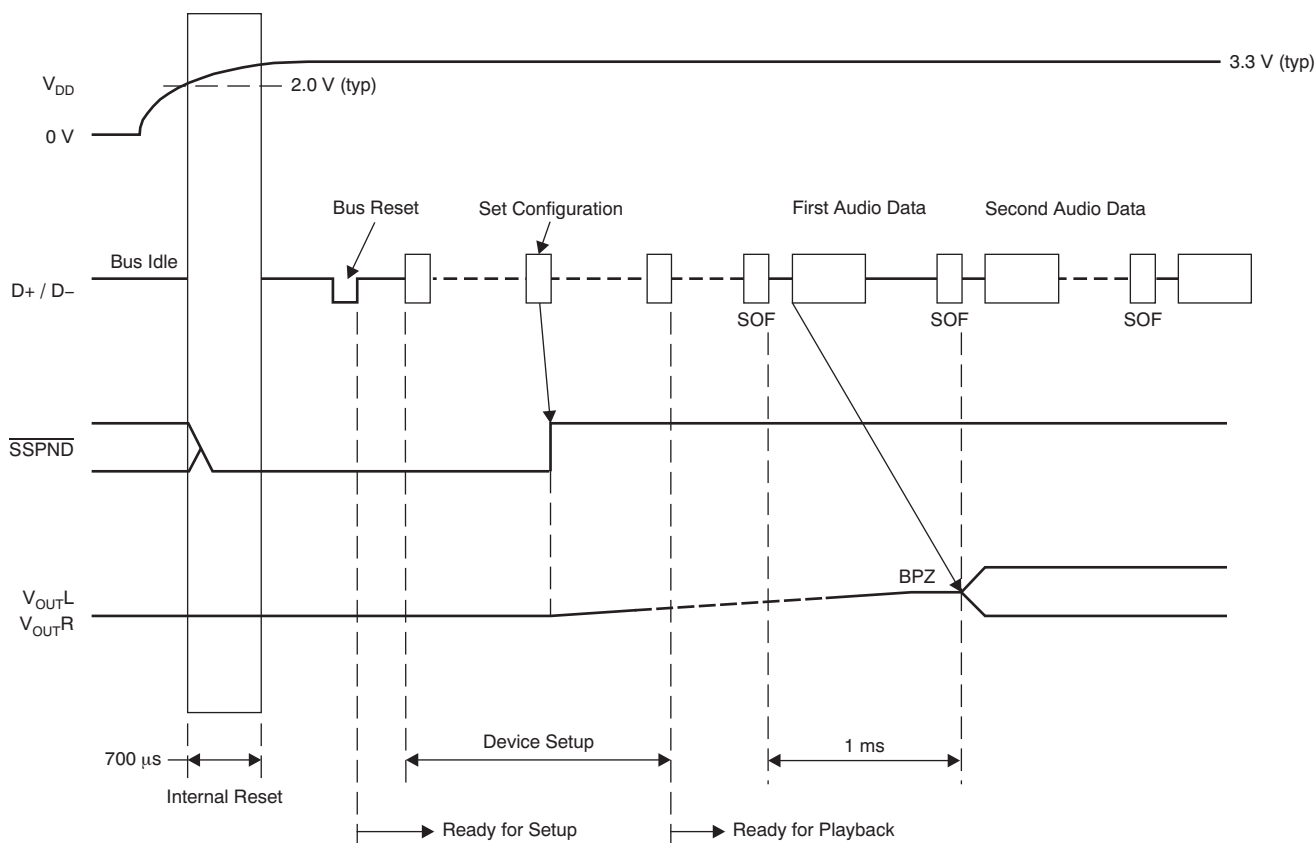

**Figure 30. Initial Sequence**

#### 9.3.10.2 Play, Stop, and Detach Sequence

When the host finishes or aborts playback, the PCM2704C/5C/6C/7C stop playing after the last audio data output is complete. Figure 31 shows the play, stop, and detach sequence.

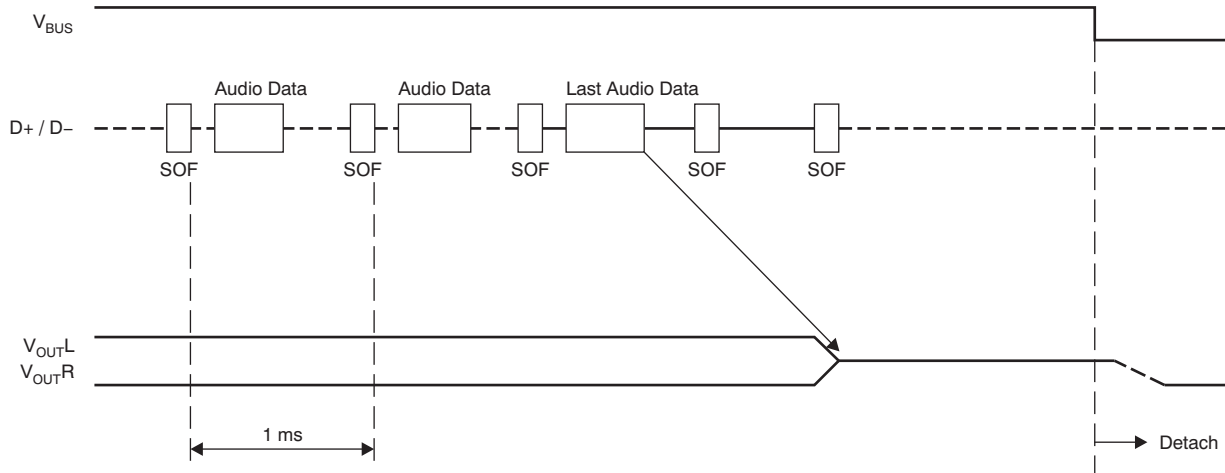

Figure 31. Play, Stop, and Detach Sequence

### 9.3.10.3 Suspend and Resume Sequence

The PCM2704C/5C/6C/7C enter a suspended state after the USB bus has been in a constant idle state for approximately 5 ms. While the PCM2704C/5C/6C/7C are in this suspended state, the  $\overline{\text{SSPND}}$  flag (pin 27 for the PCM2704C/5C, pin 11 for the PCM2706C/7C) is asserted. The PCM2704C/5C/6C/7C wake up immediately when detecting a non-idle state on the USB bus. Figure 32 shows the operating sequence for the suspend and resume process.

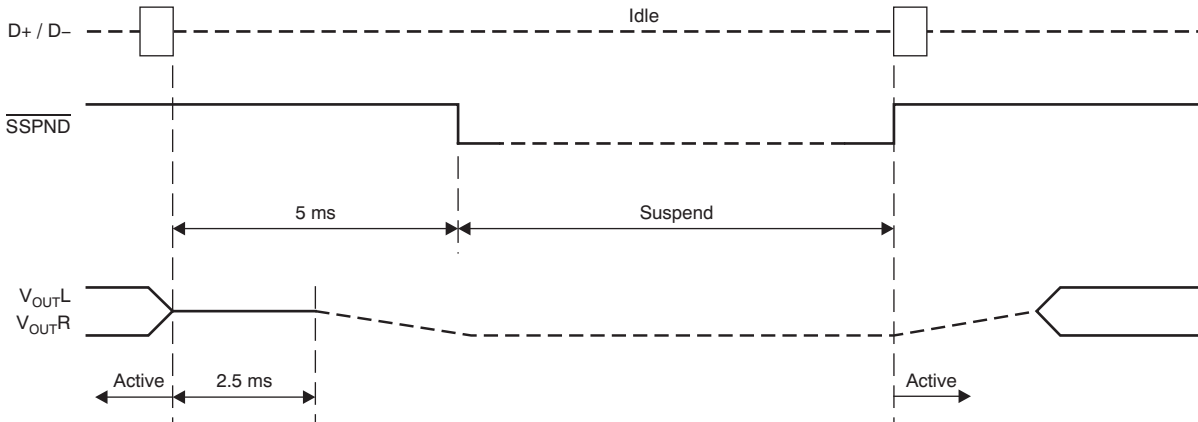

Figure 32. Suspend and Resume

### 9.3.11 Operating Environment

For current information on the PCM2704C/2705C/2706C/2707C operating environments, see the *Updated Operating Environments for PCM270X, PCM290X Applications* application report, [SLAA374](#), available through the TI website at [www.ti.com](#).

## 9.4 Device Functional Modes

The PCM2903C is a USB-controlled device. The PCM2903C is a digital-to-analog converter (DAC), with digital input (that goes to a D/A converter) and analog output, alongside the digital path to USB and S/PDIF and I2S (only in PCM2706C/7C). A wider explanation of these operational modes is shown in [Feature Description](#).

## 9.5 Programming

### 9.5.1 USB Interface

Control data and audio data are transferred to the PCM2704C/5C/6C/7C through the D+ pin (pin 9 for the PCM2704C/5C, pin 23 for the PCM2706C/7C) and D– pin (pin 8 for the PCM2704C/5C, pin 22 for the PCM2706C/7C). D+ should be pulled up with a 1.5-k $\Omega$  ( $\pm 5\%$ ) resistor. To avoid back voltage in self-powered operation, the device must not provide power to the pullup resistor on D+ while  $V_{BUS}$  of the USB port is inactive.

All data to/from the PCM2704C/5C/6C/7C are transferred at full speed. Table 4 shows the information that is provided in the device descriptor. Some parts of the device descriptor can be modified through external ROM (PCM2704C/6C) or SPI (PCM2705C/7C).

**Table 4. Device Descriptor**

DEVICE DESCRIPTOR	DESCRIPTION
USB revision	1.1 compliant
Device class	0x00 (device defined interface level)
Device subclass	0x00 (not specified)
Device protocol	0x00 (not specified)
Max packet size for endpoint 0	8 bytes
Vendor ID	0x08BB (default value, can be modified)
Product ID	0x27C4/0x27C5/0x27C6/0x27C7 (These values correspond to the model number, and the value can be modified.)
Device release number	1.0 (0x0100)
Number of configurations	1
Vendor strings	BurrBrown from Texas Instruments (default value, can be modified)
Product strings	USB AUDIO DAC (default value, can be modified)
Serial number	Not supported

Table 5 shows the information contained in the configuration descriptor. Some parts of the configuration descriptor can be modified through external ROM (PCM2704C/6C) or SPI (PCM2705C/7C).

**Table 5. Configuration Descriptor**

CONFIGURATION DESCRIPTOR	DESCRIPTION
Interface	Three interfaces
Power attribute	0x80 or 0xC0 (bus-powered or self-powered, depending on PSEL; no remote wake up. This value can be modified.)
Max power	0x0A, 0x32, or 0xFA (20 mA for self-powered, 100 mA or 500 mA for bus-powered, depending on PSEL and HOST. This value can be modified.)

Table 6 shows the information contained in the string descriptor. Some parts of the string descriptor can be modified through external ROM (PCM2704C/6C) or SPI (PCM2705C/7C).

**Table 6. String Descriptor**

STRING DESCRIPTOR	DESCRIPTION
0	0x0409
1	BurrBrown from Texas Instruments (default value, can be modified)
2	USB AUDIO DAC (default value, can be modified)

### 9.5.1.1 Device Configuration

Figure 33 shows the USB audio function topology. The PCM2704C/5C/6C/7C have three interfaces. Each interface is enabled by different alternative settings.

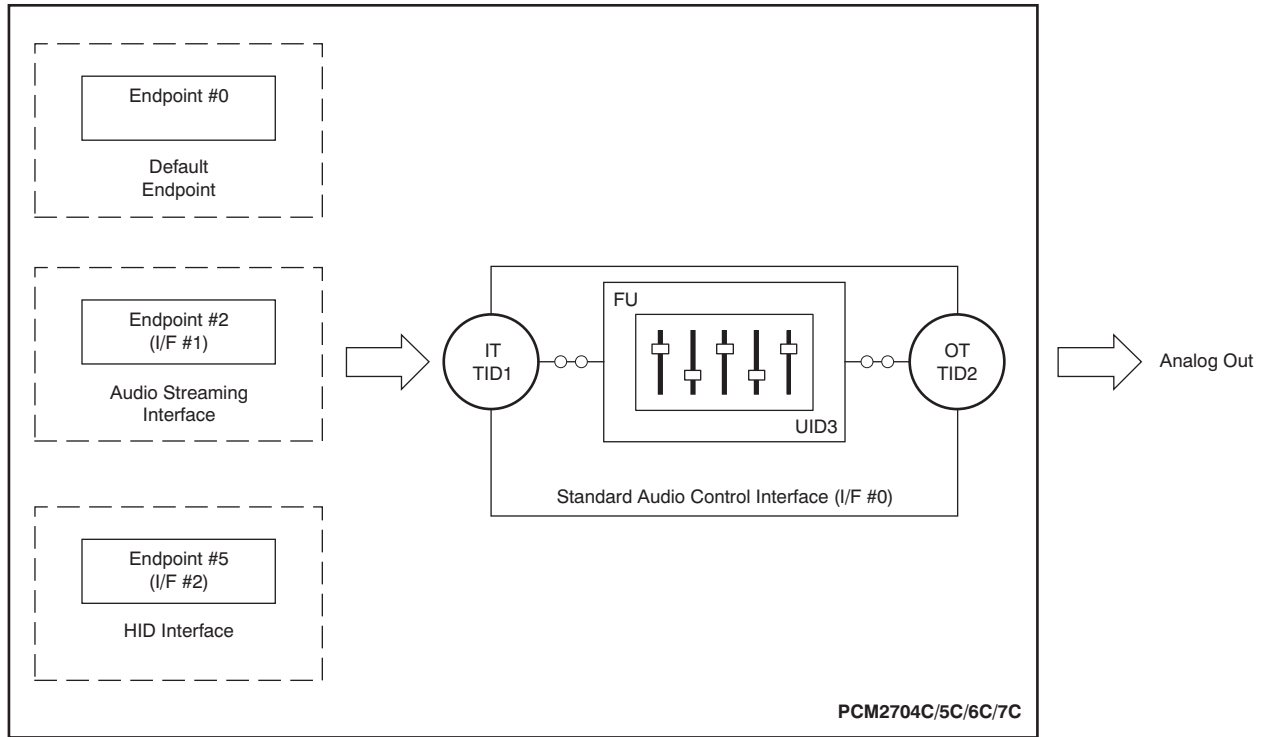

**Figure 33. USB Audio Function Topology**

### 9.5.1.2 Interface Number 0 (Default/Control Interface)

Interface number 0 is the control interface. Setting number 0 is the only possible setting for interface number 0. Setting number 0 describes the standard audio control interface. The audio control interface consists of a terminal. The PCM2704C/5C/6C/7C have three terminals:

- Input terminal (IT number 1) for isochronous-out stream
- Output terminal (OT number 2) for audio analog output
- Feature unit (FU number 3) for DAC digital attenuator

Input terminal number 1 is defined as a USB stream (terminal type 0x0101). Input terminal number 1 can accept two-channel audio streams consisting of left and right channels. Output terminal number 2 is defined as a speaker (terminal type 0x0301). Feature unit number 3 supports these sound control features:

- Volume control
- Mute control

The built-in digital volume controller can be manipulated by an audio-class-specific request from 0 to –64 dB in steps of 1 dB. Changes are made by incrementing or decrementing one step (that is, 1 dB) for every  $1 / f_s$  time interval, until the volume level reaches the requested value. Each channel can be set to a separate value. The master volume control is not supported. A request to the master volume is stalled and ignored. The built-in digital mute controller can be manipulated by an audio-class-specific request. A master mute control request is acceptable. A mute control request to an individual channel is stalled and ignored. The digital volume control does not affect either the S/PDIF or I<sup>2</sup>S outputs (PCM2706C/7C only).

### 9.5.1.3 Interface Number 1 (Isochronous-Out Interface)

Interface number 1 is for the audio-streaming data-out interface. Interface number 1 has the alternative settings described in Table 7. Alternative setting number 0 is the zero-bandwidth setting. All other alternative settings are operational settings.

**Table 7. Interface Number 1 Parameters**

ALTERNATIVE SETTING	DATA FORMAT			TRANSFER MODE	SAMPLING RATE (kHz)
00	Zero bandwidth				
01	16-bit	Stereo	2's complement (PCM)	Adaptive	32, 44.1, 48
02	16-bit	Mono	2's complement (PCM)	Adaptive	32, 44.1, 48

### 9.5.1.4 Interface Number 2 (HID Interface)

Interface number 2 is the interrupt-data-in interface. The HID consumer control device consists of interface number 2. Alternative setting number 0 is the only possible setting for interface number 2.

On the HID device descriptor, eight HID items are reported for any model, in any configuration.

#### 9.5.1.4.1 HID Items Reported

##### 9.5.1.4.1.1 Basic HID Operation

Interface number 2 can report these three key statuses for any model. These statuses can be set by the HID0 through HID2 pins (PCM2704C/6C) or the SPI port (PCM2705C/7C).

- Mute (0xE2)
- Volume up (0xE9)
- Volume down (0xEA)

##### 9.5.1.4.1.2 Extended HID Operation (PCM2705/6/7)

By using the FUNC0 through FUNC3 pins (PCM2706C) or the SPI port (PCM2705C/7C), these additional conditions can be reported to the host.

- Play/Pause (0xCD)
- Stop (0xB7)
- Previous (0xB6)
- Next (0xB5)

##### 9.5.1.4.1.3 Auxiliary HID Status Report (PCM2705C/7C)

One additional HID status can be reported to the host through the SPI port. This status flag is defined by SPI command or external ROM. This definition must be described as on the report descriptor with a three-byte usage ID. *AL A/V Capture* (0x0193) is assigned as the default value for this status flag.

### 9.5.1.5 Endpoints

The PCM2704C/5C/6C/7C has three endpoints:

- Control endpoint (EP number 0)
- Isochronous-out audio data-stream endpoint (EP number 2)
- HID endpoint (EP number 5)

The control endpoint is a default endpoint. The control endpoint controls all functions of the PCM2704C/5C/6C/7C by standard USB request and USB audio-class-specific request from the host. The isochronous-out audio data-stream endpoint is an audio sink endpoint that receives the PCM audio data. The isochronous-out audio data-stream endpoint accepts the adaptive transfer mode. The HID endpoint is an interrupt-in endpoint. The HID endpoint reports HID status every 10 ms.

The HID endpoint is defined as a consumer-control device. The HID function is designed as an independent endpoint from the isochronous-out endpoint. This configuration means that the effect of HID operation depends on the host software. Typically, the HID function controls the primary audio-out device.

## 9.6 Register Maps

### 9.6.1 SPI Register (PCM2705C/7C)

#### NOTE

Contents of the power attribute and max power must be consistent with the actual application circuit configuration (the PSEL setting and the actual power usage from  $V_{BUS}$  of the USB connector); otherwise, it may cause improper or unexpected PCM2705C/7C operation.

**Figure 34. SPI Register Description**

15	14	13	12	11	10	9	8	7	6	5	4	3	2	1	0
0	0	0	0	ST	0	ADDR	0	D0	D1	D2	D3	D4	D5	D6	D7

LEGEND: R/W = Read/Write; R = Read only; -n = value after reset

**Table 8. SPI Register Field Descriptions<sup>(1)</sup>**

Bit	Field	Type	Reset	Description
11	ST			<b>Determines the function of the lower 8-bit data.</b> Table 9 summarizes the functionality of ST and ADDR bit combinations. 0: HID status write 1: Descriptor ROM data write
9	ADDR			<b>Starts write operation for internal descriptor reprogramming (active high)</b> This bit resets the descriptor ROM address counter and indicates that subsequent words should be ROM data (described in <a href="#">External ROM Example</a> ). 456 bits of ROM data must be continuously followed after this bit has been asserted. The data bits must be sent from LSB (D0) to MSB (D7). To set ADDR high, ST must be set low. Note that the lower 8 bits are still active as an HID status write when ST is set low.
7	D0			ST = 0 (HID status write); Reports extended command status to the host (active high) ST = 1 (ROM data write); Internal descriptor ROM data, D0:LSB
6	D1			ST = 0 (HID status write); Reports play/pause HID status to the host (active high) ST = 1 (ROM data write); Internal descriptor ROM data
5	D2			ST = 0 (HID status write); Reports stop HID status to the host (active high) ST = 1 (ROM data write); Internal descriptor ROM data
4	D3			ST = 0 (HID status write); Reports previous-track HID status to the host (active high) ST = 1 (ROM data write); Internal descriptor ROM data
3	D4			ST = 0 (HID status write); Reports next-track HID status to the host (active high) ST = 1 (ROM data write); Internal descriptor ROM data
2	D5			ST = 0 (HID status write); Reports volume-down HID status to the host (active high) ST = 1 (ROM data write); Internal descriptor ROM data
1	D6			ST = 0 (HID status write); Reports volume-up HID status to the host (active high) ST = 1 (ROM data write); Internal descriptor ROM data
0	D7			ST = 0 (HID status write); Reports MUTE HID status to the host (active high) ST = 1 (ROM data write); Internal descriptor ROM data, D7:MSB

(1) D[7:0] – Function of the lower 8 bits depends on the value of the ST (B11) bit.

**Table 9. Functionality of ST and ADDR Bit Combinations**

ST	ADDR	FUNCTION
0	0	HIS status write
0	1	HIS status write and descriptor ROM address reset
1	0	Descriptor ROM data write
1	1	Reserved

## 10 Application and Implementation

---

### NOTE

Information in the following applications sections is not part of the TI component specification, and TI does not warrant its accuracy or completeness. TI's customers are responsible for determining suitability of components for their purposes. Customers should validate and test their design implementation to confirm system functionality.

---

### 10.1 Application Information

The PSEL allows the device to configure for bus-powered mode (High) or self-powered mode (Low). The HOST pin configures the maximum current consumption of the device during bus-powered mode (low: 100 mA, high: 500 mA), or can be used as host detector during self-powered mode. The SSPND flag notifies when the USB input is idle for at least 5 ms; this flag can be used to control or notify subsequent circuits. The device descriptor can be modified by using an external ROM (PCM2704C/6C) or through the SPI port (PCM2705C/7C); this descriptor programming function is only available when PSEL and HOST are high. More functional details can be found in [USB Interface](#).

### 10.2 Typical Application

#### 10.2.1 Typical Circuit Connection 1: USB Speaker

[Figure 35](#) shows a typical circuit connection for an internal-descriptor, bus-powered, 500-mA application.



## Typical Application (continued)

### 10.2.1.1 Design Requirements

For this design example, use the parameters listed in [Table 10](#).

**Table 10. Design Parameters**

DESIGN PARAMETER	EXAMPLE VALUE
Input voltage range	4.35 V to 5.25 V (USB power)
Current	500 mA (Bus-Powered Max power)
Input clock frequency	11.994 MHz to 12.006 MHz

### 10.2.1.2 Detailed Design Procedure

The PCM2704C/5C/6C/7C is a simple design device that can connect directly to a USB port. Only a 3.3-V external regulator is needed (in self-powered mode), and an external ROM for the descriptor programming function (PCM2704C/6C). The switches connected to the HID ports must be normally open. TI recommends placing an output filter such as the one shown in [Figure 35](#). The PCM2704C/5C/6C/7C requires decoupling capacitors on the voltage source pins.

### 10.2.1.3 Application Curves

For the application curves, see the graphs listed in [Table 11](#).

**Table 11. Table of Graphs**

		FIGURE
DAC Digital Interpolation Filter Frequency Response	Frequency Response	<a href="#">Figure 6</a>
	Passband Ripple	<a href="#">Figure 7</a>
DAC Analog Low-Pass Filter Frequency Response	Passband Characteristics	<a href="#">Figure 8</a>
	Stop Band Characteristics	<a href="#">Figure 9</a>

10.2.2 Typical Circuit Connection 2: Remote Headphone

Figure 36 shows a typical circuit connection for a bus-powered, 100-mA headphone with seven HIDs.

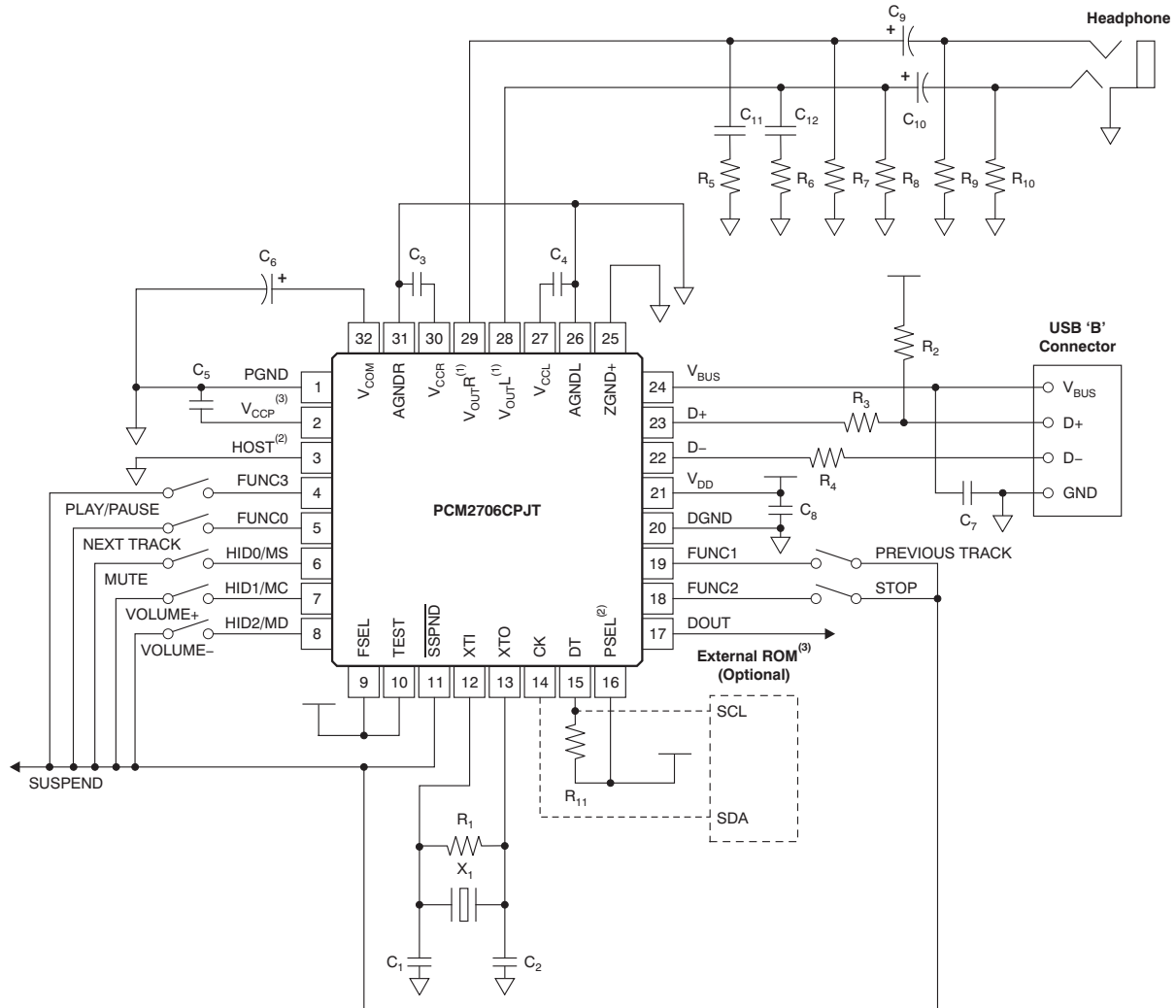

NOTE: X<sub>1</sub>: 12-MHz crystal resonator. C<sub>1</sub>, C<sub>2</sub>: 10- to 33-pF capacitors (depending on load capacitance of crystal resonator). C<sub>3</sub> to C<sub>5</sub>, C<sub>7</sub>, C<sub>8</sub>: 1-μF ceramic capacitors. C<sub>6</sub>: 10-μF electrolytic capacitor. C<sub>9</sub>, C<sub>10</sub>: 100-μF electrolytic capacitors (depending on required frequency response). C<sub>11</sub>, C<sub>12</sub>: 0.022-μF ceramic capacitors. R<sub>1</sub>: 1-MΩ resistor. R<sub>2</sub>, R<sub>11</sub>: 1.5-kΩ resistors. R<sub>3</sub>, R<sub>4</sub>: 22-Ω resistors. R<sub>5</sub>, R<sub>6</sub>: 16-Ω resistors. R<sub>7</sub> to R<sub>10</sub>: 3.3-kΩ resistors.

- (1) Output impedance of V<sub>OUTL</sub> and V<sub>OUTR</sub> during suspend mode or lack of power supply is 26 kΩ ±20%, which is the discharge path for C<sub>9</sub> and C<sub>10</sub>.
- (2) Descriptor programming through external ROM is only available when PSEL and HOST are high.
- (3) External ROM power can be supplied from V<sub>CCP</sub>, but any other active component must not use V<sub>CCP</sub>, V<sub>CCL</sub>, V<sub>CCL</sub>, or V<sub>DD</sub> as a power source.

Figure 36. Bus-Powered Application

NOTE

The circuit shown in Figure 36 is for information only. The entire board design should be considered to meet the USB specification as a USB-compliant product.

### 10.2.2.1 Design Requirements

For this design example, use the parameters listed in [Table 12](#).

**Table 12. Design Parameters**

DESIGN PARAMETER	EXAMPLE VALUE
Input voltage range	4.35 V to 5.25 V (USB power)
Current	100 mA (Bus-Powered Max power)
Input clock frequency	11.994 MHz to 12.006 MHz

### 10.2.2.2 Detailed Design Procedure

A general detailed design procedure is explained in [Detailed Design Procedure](#).

### 10.2.2.3 Application Curves

For the application curves, see the graphs listed in [Table 11](#).

### 10.2.3 Typical Circuit Connection 3: DSP Surround Processing Amplifier

Figure 37 shows a typical circuit connection for an I<sup>2</sup>S- and SPI-enabled self-powered application.

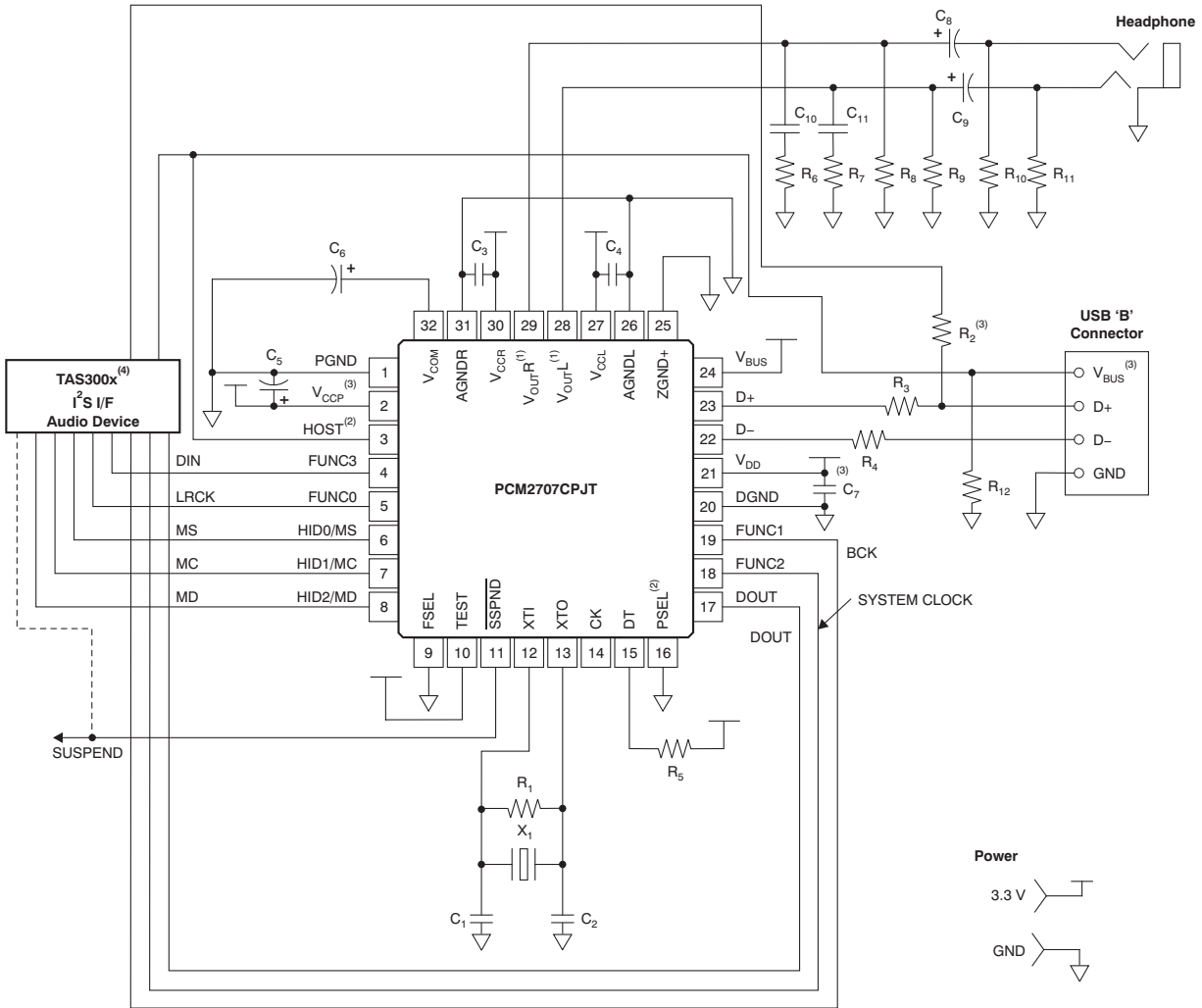

NOTE: X<sub>1</sub>: 12-MHz crystal resonator. C<sub>1</sub>, C<sub>2</sub>: 10- to 33-pF capacitors (depending on load capacitance of crystal resonator). C<sub>3</sub>, C<sub>4</sub>: 1-μF ceramic capacitors. C<sub>5</sub>, C<sub>7</sub>: 0.1-μF ceramic capacitor and 10-μF electrolytic capacitor. C<sub>6</sub>: 10-μF electrolytic capacitors. C<sub>8</sub>, C<sub>9</sub>: 100-μF electrolytic capacitors (depending on required frequency response). C<sub>10</sub>, C<sub>11</sub>: 0.022-μF ceramic capacitors. R<sub>1</sub>, R<sub>12</sub>: 1-MΩ resistors. R<sub>2</sub>, R<sub>5</sub>: 1.5-kΩ resistors. R<sub>3</sub>, R<sub>4</sub>: 22-Ω resistors. R<sub>6</sub>, R<sub>7</sub>: 16-Ω resistors. R<sub>8</sub> to R<sub>11</sub>: 3.3-kΩ resistors.

(1) Output impedance of V<sub>OUTL</sub> and V<sub>OUTR</sub> during suspend mode or lack of power supply is 26 kΩ ±20%, which is the discharge path for C<sub>8</sub> and C<sub>9</sub>.

(2) Descriptor programming through SPI is only available when PSEL and HOST are high.

(3) D+ pullup must not be activated (high: 3.3 V) while the device is detached from USB or power supply is not applied on V<sub>DD</sub> and V<sub>CCx</sub>. V<sub>BUS</sub> of USB (5 V) can be used to detect USB power status.

(4) MS must be high until the PCM2707C power supply is ready and the SPI host (the DSP) is ready to send data. Also, the SPI host must handle the D+ pullup if the descriptor is programmed through the SPI. D+ pullup must not be activated (high = 3.3 V) before programming of the PCM2707C through the SPI is complete.

**Figure 37. Self-Powered Application**

#### NOTE

The circuit shown in Figure 37 is for information only. The entire board design should be considered to meet the USB specification as a USB-compliant product.

### 10.2.3.1 Design Requirements

For this design example, use the parameters listed in [Table 13](#).

**Table 13. Design Parameters**

DESIGN PARAMETER	EXAMPLE VALUE
Input voltage range	3 V to 3.6 V
Current	100 mA
Input clock frequency	11.994 MHz to 12.006 MHz

### 10.2.3.2 Detailed Design Procedure

A general detailed design procedure is explained in [Detailed Design Procedure](#).

### 10.2.3.3 Application Curves

For the application curves, see the graphs listed in [Table 11](#).

## 11 Power Supply Recommendations

The voltage source required to power the PCM2704C/5C/6C/7C must be between 3 V and 3.6 V for proper operation (self-powered mode). TI recommends placing a decoupling capacitor in every voltage source pin. This helps filter lower frequency power supply noise. Place these decoupling capacitors as close as possible to the PCM2704C/5C/6C/7C.

## 12 Layout

### 12.1 Layout Guidelines

The decoupling capacitors must be as close as possible to the PCM2704C/5C/6C/7C pins. TI recommends placing an output filter such as the one shown in [Detailed Design Procedure](#). The PCM2704C/5C/6C/7C is a low power device, so there is no need for a special heat sink PCB design.

### 12.2 Layout Example

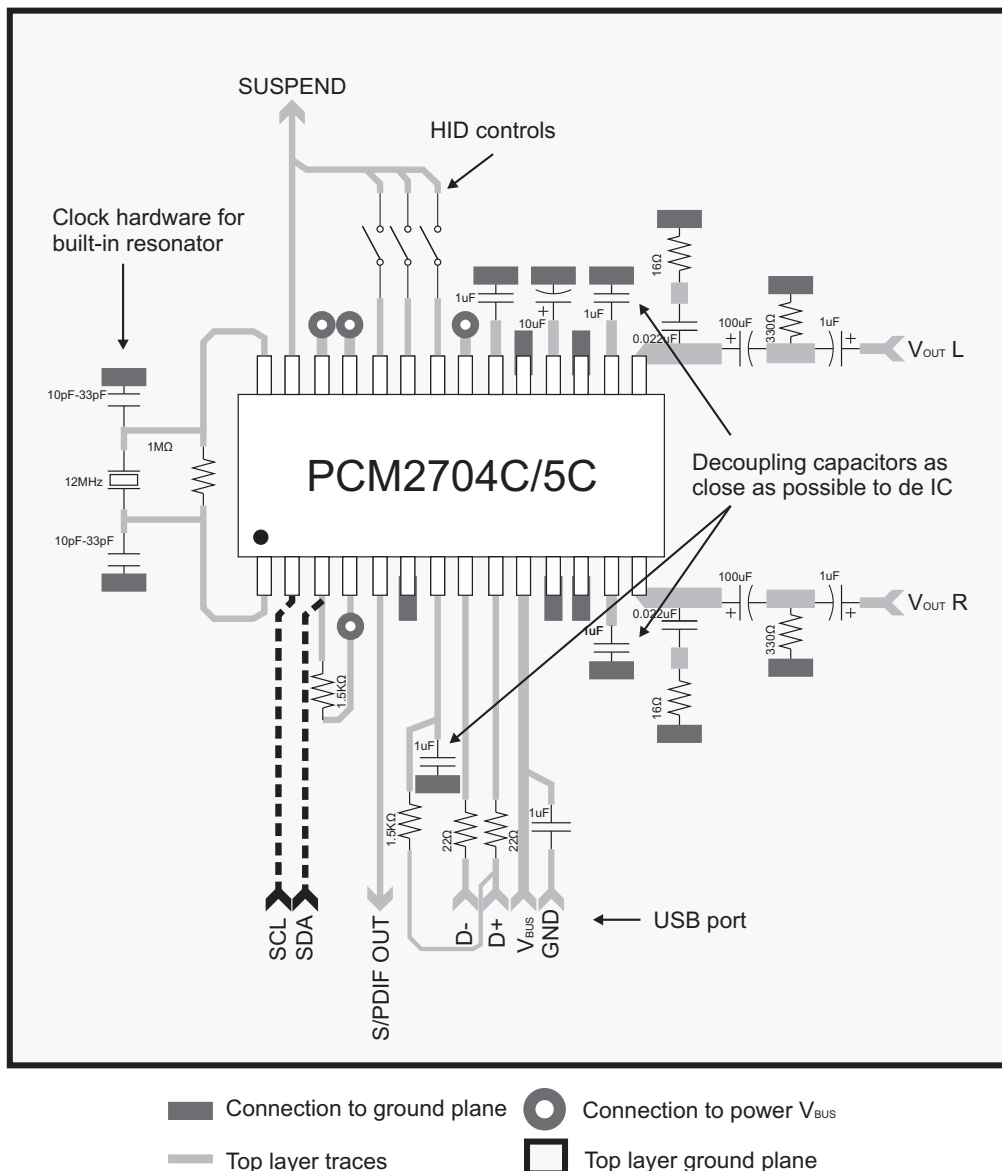
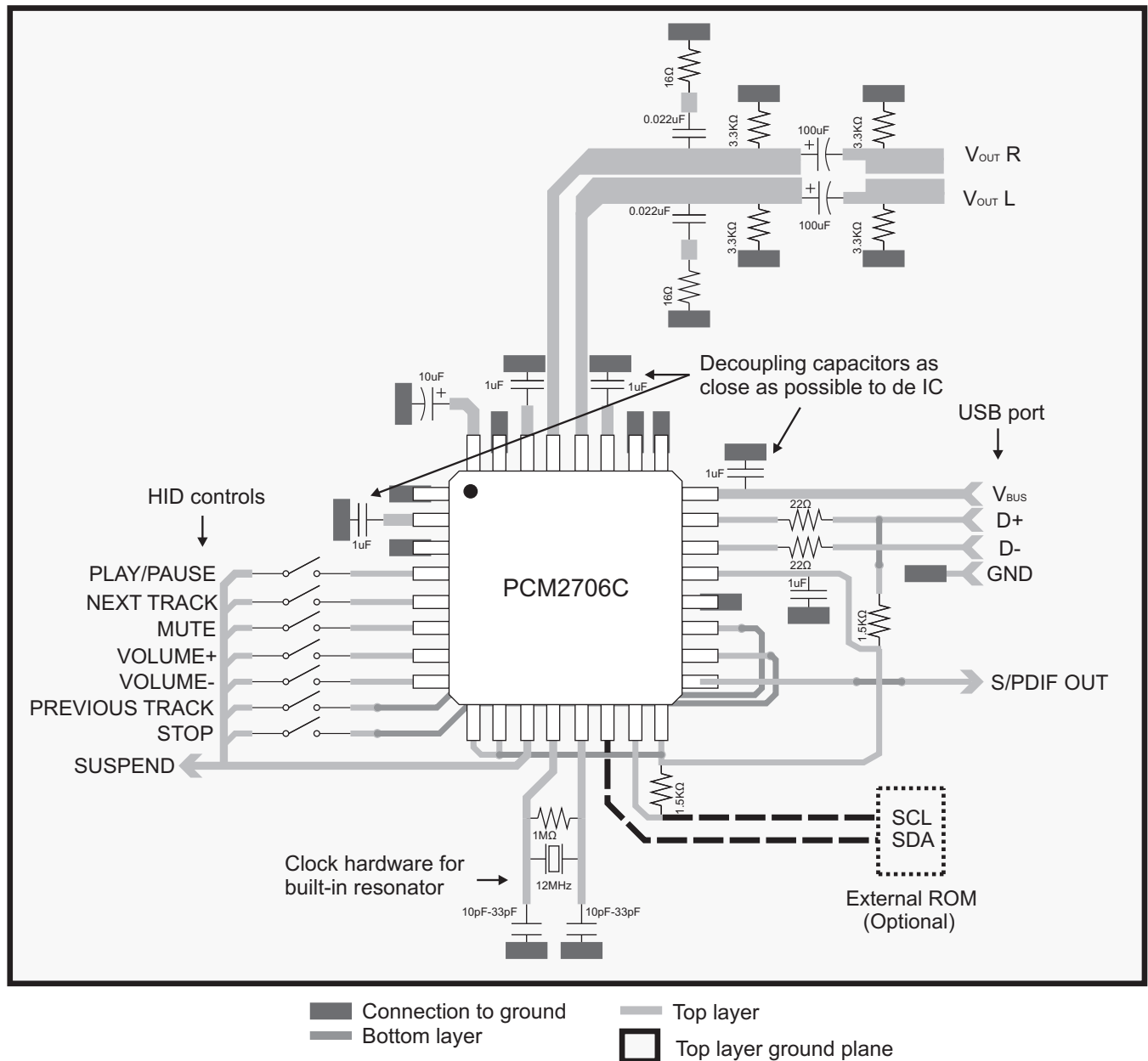

Figure 38. Layout Example 1

**Layout Example (continued)**



**Figure 39. Layout Example 2**

Layout Example (continued)

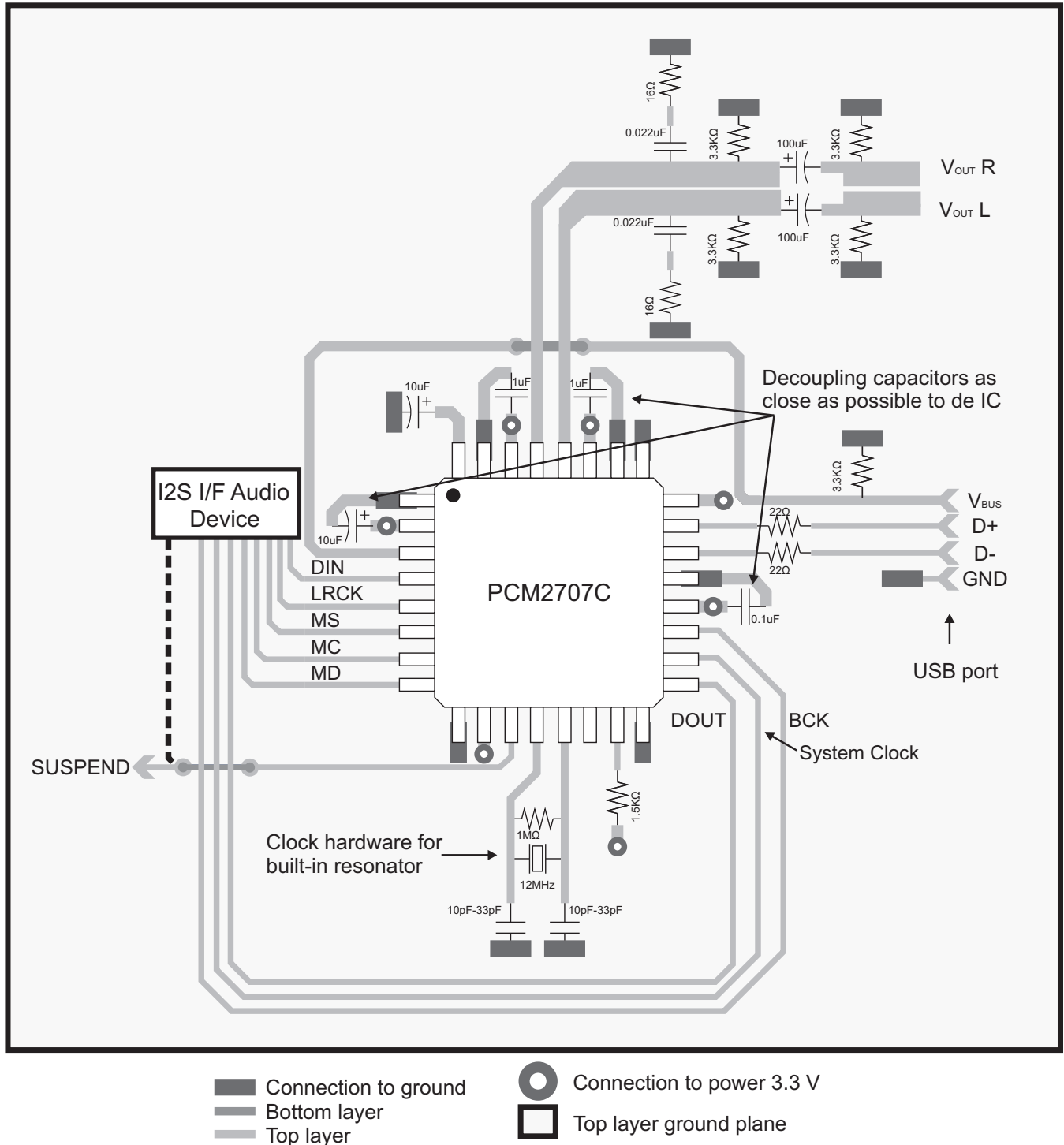

Figure 40. Layout Example 3

## 13 Device and Documentation Support

### 13.1 Documentation Support

#### 13.1.1 Related Documentation

For related documentation, see the *Updated Operating Environments for PCM270x, PCM290x Applications, SLAA374*.

### 13.2 Related Links

The table below lists quick access links. Categories include technical documents, support and community resources, tools and software, and quick access to sample or buy.

**Table 14. Related Links**

PARTS	PRODUCT FOLDER	SAMPLE & BUY	TECHNICAL DOCUMENTS	TOOLS & SOFTWARE	SUPPORT & COMMUNITY
PCM2704C	<a href="#">Click here</a>	<a href="#">Click here</a>	<a href="#">Click here</a>	<a href="#">Click here</a>	<a href="#">Click here</a>
PCM2705C	<a href="#">Click here</a>	<a href="#">Click here</a>	<a href="#">Click here</a>	<a href="#">Click here</a>	<a href="#">Click here</a>
PCM2706C	<a href="#">Click here</a>	<a href="#">Click here</a>	<a href="#">Click here</a>	<a href="#">Click here</a>	<a href="#">Click here</a>
PCM2707C	<a href="#">Click here</a>	<a href="#">Click here</a>	<a href="#">Click here</a>	<a href="#">Click here</a>	<a href="#">Click here</a>

### 13.3 Community Resources

The following links connect to TI community resources. Linked contents are provided "AS IS" by the respective contributors. They do not constitute TI specifications and do not necessarily reflect TI's views; see TI's [Terms of Use](#).

**TI E2E™ Online Community** *TI's Engineer-to-Engineer (E2E) Community*. Created to foster collaboration among engineers. At [e2e.ti.com](http://e2e.ti.com), you can ask questions, share knowledge, explore ideas and help solve problems with fellow engineers.

**Design Support** *TI's Design Support* Quickly find helpful E2E forums along with design support tools and contact information for technical support.

### 13.4 Trademarks

SpAct, E2E are trademarks of Texas Instruments.  
 System Two Cascade is a trademark of Audio Precision, Inc.  
 Audio Precision is a registered trademark of Audio Precision, Inc.  
 All other trademarks are the property of their respective owners.

### 13.5 Electrostatic Discharge Caution



These devices have limited built-in ESD protection. The leads should be shorted together or the device placed in conductive foam during storage or handling to prevent electrostatic damage to the MOS gates.

### 13.6 Glossary

[SLYZ022](#) — *TI Glossary*.

This glossary lists and explains terms, acronyms, and definitions.

## 14 Mechanical, Packaging, and Orderable Information

The following pages include mechanical, packaging, and orderable information. This information is the most current data available for the designated devices. This data is subject to change without notice and revision of this document. For browser-based versions of this data sheet, refer to the left-hand navigation.

**PACKAGING INFORMATION**

Orderable Device	Status (1)	Package Type	Package Drawing	Pins	Package Qty	Eco Plan (2)	Lead/Ball Finish (6)	MSL Peak Temp (3)	Op Temp (°C)	Device Marking (4/5)	Samples
PCM2704CDB	ACTIVE	SSOP	DB	28	50	Green (RoHS & no Sb/Br)	CU NIPDAU	Level-1-260C-UNLIM	-25 to 85	PCM2704C	<a href="#">Samples</a>
PCM2704CDBR	ACTIVE	SSOP	DB	28	2000	Green (RoHS & no Sb/Br)	CU NIPDAU	Level-1-260C-UNLIM	-25 to 85	PCM2704C	<a href="#">Samples</a>
PCM2705CDB	ACTIVE	SSOP	DB	28	50	Green (RoHS & no Sb/Br)	CU NIPDAU	Level-1-260C-UNLIM	-25 to 85	PCM2705C	<a href="#">Samples</a>
PCM2705CDBR	ACTIVE	SSOP	DB	28	2000	Green (RoHS & no Sb/Br)	CU NIPDAU	Level-1-260C-UNLIM	-25 to 85	PCM2705C	<a href="#">Samples</a>
PCM2706CPJT	ACTIVE	TQFP	PJT	32	250	Green (RoHS & no Sb/Br)	CU NIPDAU	Level-1-260C-UNLIM	-25 to 85	PCM2706C	<a href="#">Samples</a>
PCM2706CPJTR	ACTIVE	TQFP	PJT	32	1000	Green (RoHS & no Sb/Br)	CU NIPDAU	Level-1-260C-UNLIM	-25 to 85	PCM2706C	<a href="#">Samples</a>
PCM2707CPJTR	ACTIVE	TQFP	PJT	32	1000	Green (RoHS & no Sb/Br)	CU NIPDAU	Level-1-260C-UNLIM	-25 to 85	PCM2707C	<a href="#">Samples</a>

(1) The marketing status values are defined as follows:

**ACTIVE:** Product device recommended for new designs.

**LIFEBUY:** TI has announced that the device will be discontinued, and a lifetime-buy period is in effect.

**NRND:** Not recommended for new designs. Device is in production to support existing customers, but TI does not recommend using this part in a new design.

**PREVIEW:** Device has been announced but is not in production. Samples may or may not be available.

**OBSELETE:** TI has discontinued the production of the device.

(2) **RoHS:** TI defines "RoHS" to mean semiconductor products that are compliant with the current EU RoHS requirements for all 10 RoHS substances, including the requirement that RoHS substance do not exceed 0.1% by weight in homogeneous materials. Where designed to be soldered at high temperatures, "RoHS" products are suitable for use in specified lead-free processes. TI may reference these types of products as "Pb-Free".

**RoHS Exempt:** TI defines "RoHS Exempt" to mean products that contain lead but are compliant with EU RoHS pursuant to a specific EU RoHS exemption.

**Green:** TI defines "Green" to mean the content of Chlorine (Cl) and Bromine (Br) based flame retardants meet JS709B low halogen requirements of <=100ppm threshold. Antimony trioxide based flame retardants must also meet the <=1000ppm threshold requirement.

(3) MSL, Peak Temp. - The Moisture Sensitivity Level rating according to the JEDEC industry standard classifications, and peak solder temperature.

(4) There may be additional marking, which relates to the logo, the lot trace code information, or the environmental category on the device.

(5) Multiple Device Markings will be inside parentheses. Only one Device Marking contained in parentheses and separated by a "-" will appear on a device. If a line is indented then it is a continuation of the previous line and the two combined represent the entire Device Marking for that device.

<sup>(6)</sup> Lead/Ball Finish - Orderable Devices may have multiple material finish options. Finish options are separated by a vertical ruled line. Lead/Ball Finish values may wrap to two lines if the finish value exceeds the maximum column width.

**Important Information and Disclaimer:** The information provided on this page represents TI's knowledge and belief as of the date that it is provided. TI bases its knowledge and belief on information provided by third parties, and makes no representation or warranty as to the accuracy of such information. Efforts are underway to better integrate information from third parties. TI has taken and continues to take reasonable steps to provide representative and accurate information but may not have conducted destructive testing or chemical analysis on incoming materials and chemicals. TI and TI suppliers consider certain information to be proprietary, and thus CAS numbers and other limited information may not be available for release.

In no event shall TI's liability arising out of such information exceed the total purchase price of the TI part(s) at issue in this document sold by TI to Customer on an annual basis.

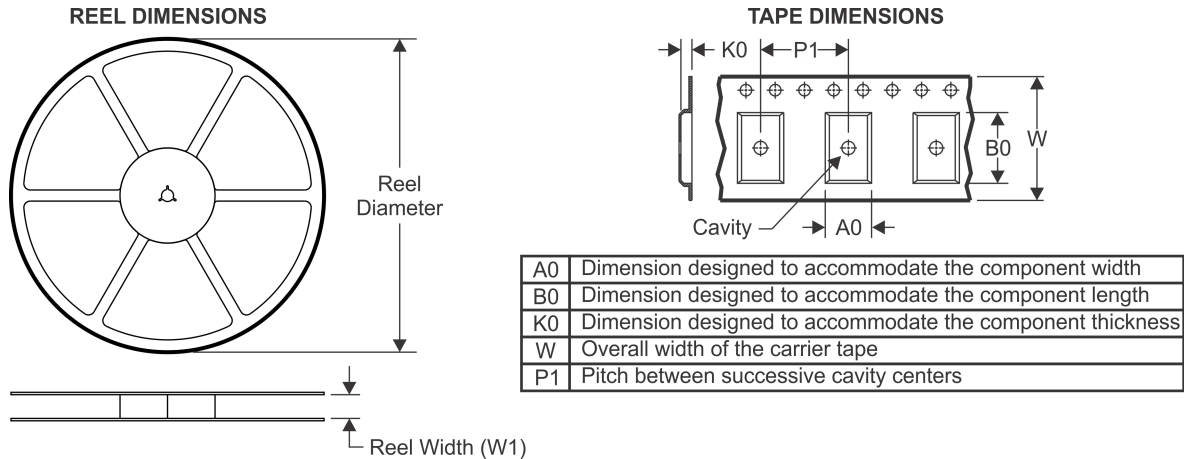
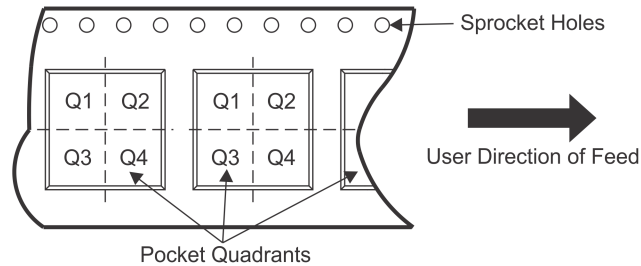
**TAPE AND REEL INFORMATION**

**QUADRANT ASSIGNMENTS FOR PIN 1 ORIENTATION IN TAPE**

\*All dimensions are nominal

Device	Package Type	Package Drawing	Pins	SPQ	Reel Diameter (mm)	Reel Width W1 (mm)	A0 (mm)	B0 (mm)	K0 (mm)	P1 (mm)	W (mm)	Pin1 Quadrant
PCM2705CDBR	SSOP	DB	28	2000	330.0	16.4	8.2	10.5	2.5	12.0	16.0	Q1
PCM2706CPJTR	TQFP	PJT	32	1000	330.0	16.8	9.6	9.6	1.5	12.0	16.0	Q2
PCM2707CPJTR	TQFP	PJT	32	1000	330.0	16.8	9.6	9.6	1.5	12.0	16.0	Q2

**TAPE AND REEL BOX DIMENSIONS**

\*All dimensions are nominal

Device	Package Type	Package Drawing	Pins	SPQ	Length (mm)	Width (mm)	Height (mm)
PCM2705CDBR	SSOP	DB	28	2000	367.0	367.0	38.0
PCM2706CPJTR	TQFP	PJT	32	1000	367.0	367.0	38.0
PCM2707CPJTR	TQFP	PJT	32	1000	367.0	367.0	38.0

# DB0028A



# PACKAGE OUTLINE

## SSOP - 2 mm max height

SMALL OUTLINE PACKAGE

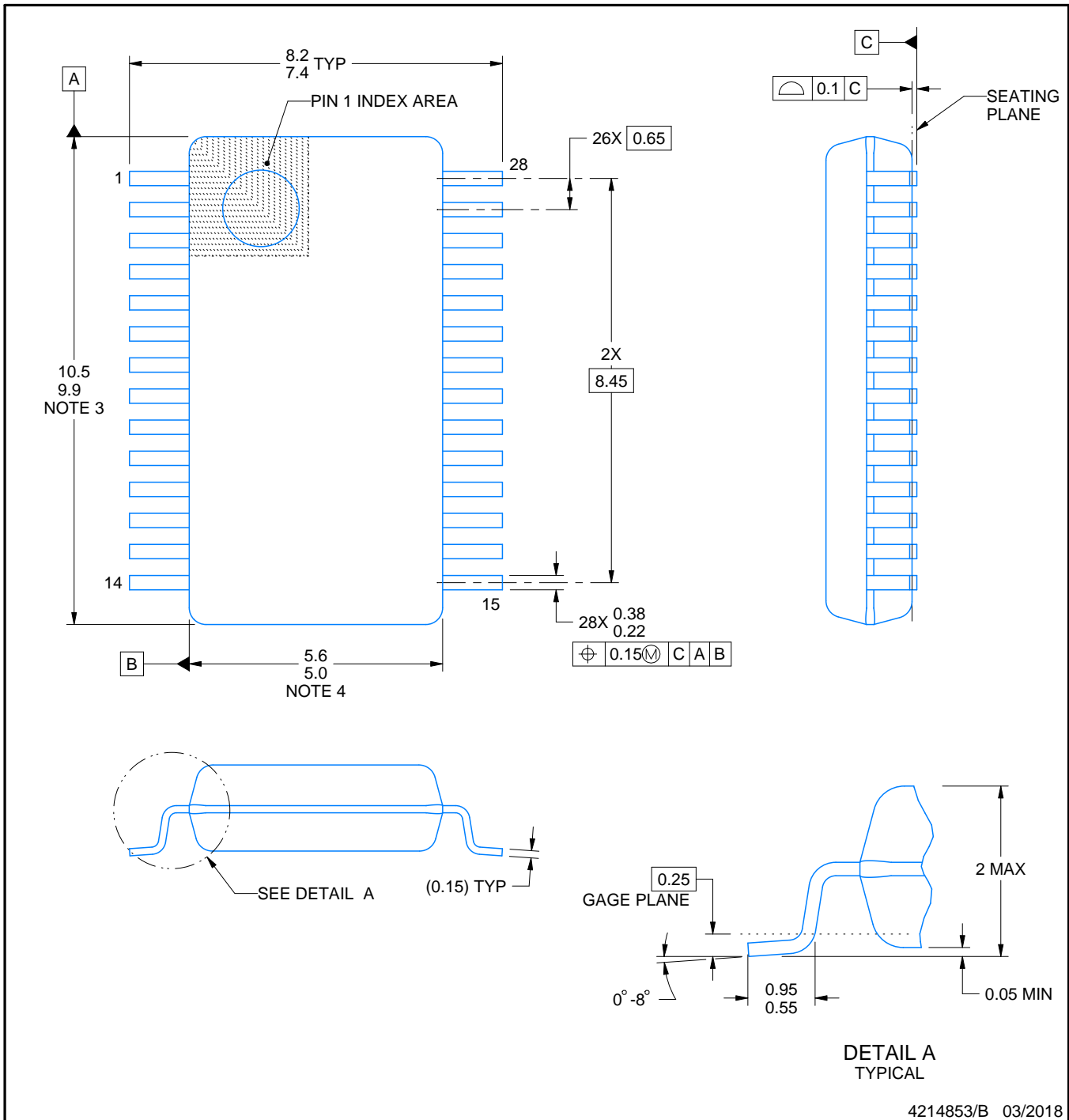

4214853/B 03/2018

### NOTES:

1. All linear dimensions are in millimeters. Any dimensions in parenthesis are for reference only. Dimensioning and tolerancing per ASME Y14.5M.
2. This drawing is subject to change without notice.
3. This dimension does not include mold flash, protrusions, or gate burrs. Mold flash, protrusions, or gate burrs shall not exceed 0.15 mm per side.
4. This dimension does not include interlead flash. Interlead flash shall not exceed 0.25 mm per side.
5. Reference JEDEC registration MO-150.

# EXAMPLE BOARD LAYOUT

DB0028A

SSOP - 2 mm max height

SMALL OUTLINE PACKAGE

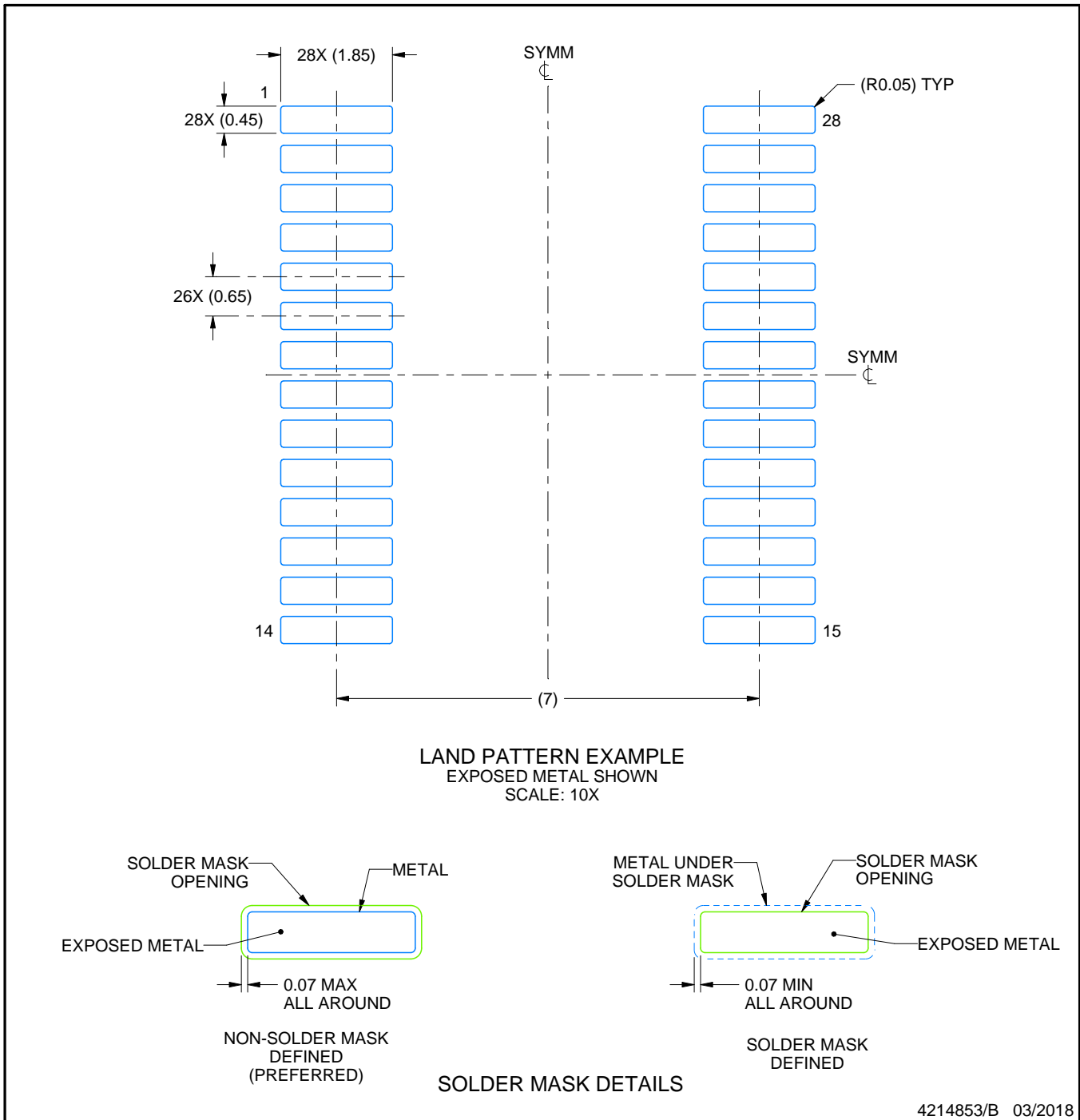

NOTES: (continued)

6. Publication IPC-7351 may have alternate designs.
7. Solder mask tolerances between and around signal pads can vary based on board fabrication site.

# EXAMPLE STENCIL DESIGN

DB0028A

SSOP - 2 mm max height

SMALL OUTLINE PACKAGE

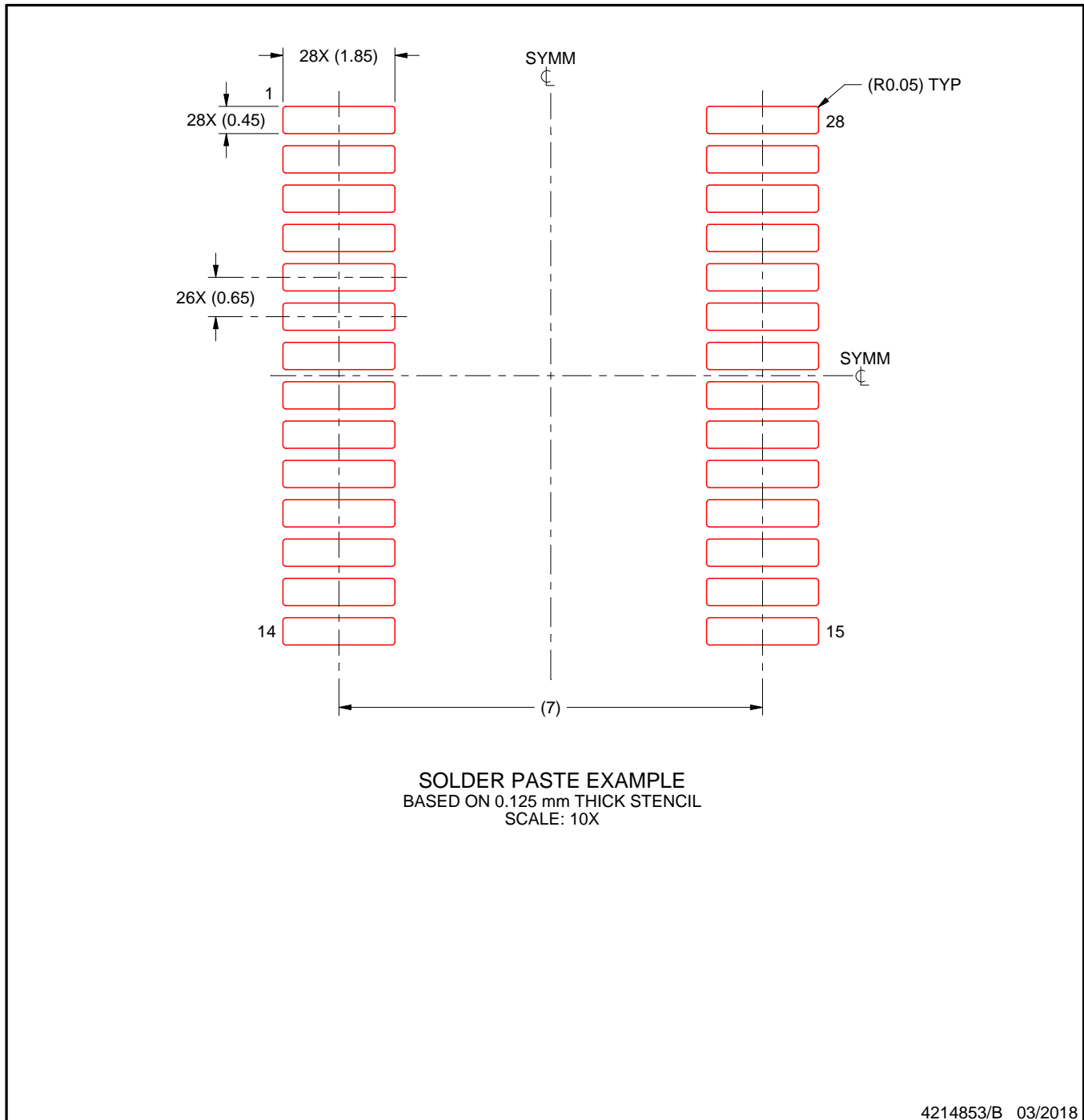

NOTES: (continued)

8. Laser cutting apertures with trapezoidal walls and rounded corners may offer better paste release. IPC-7525 may have alternate design recommendations.
9. Board assembly site may have different recommendations for stencil design.

PJT (S-PQFP-N32)

PLASTIC QUAD FLATPACK

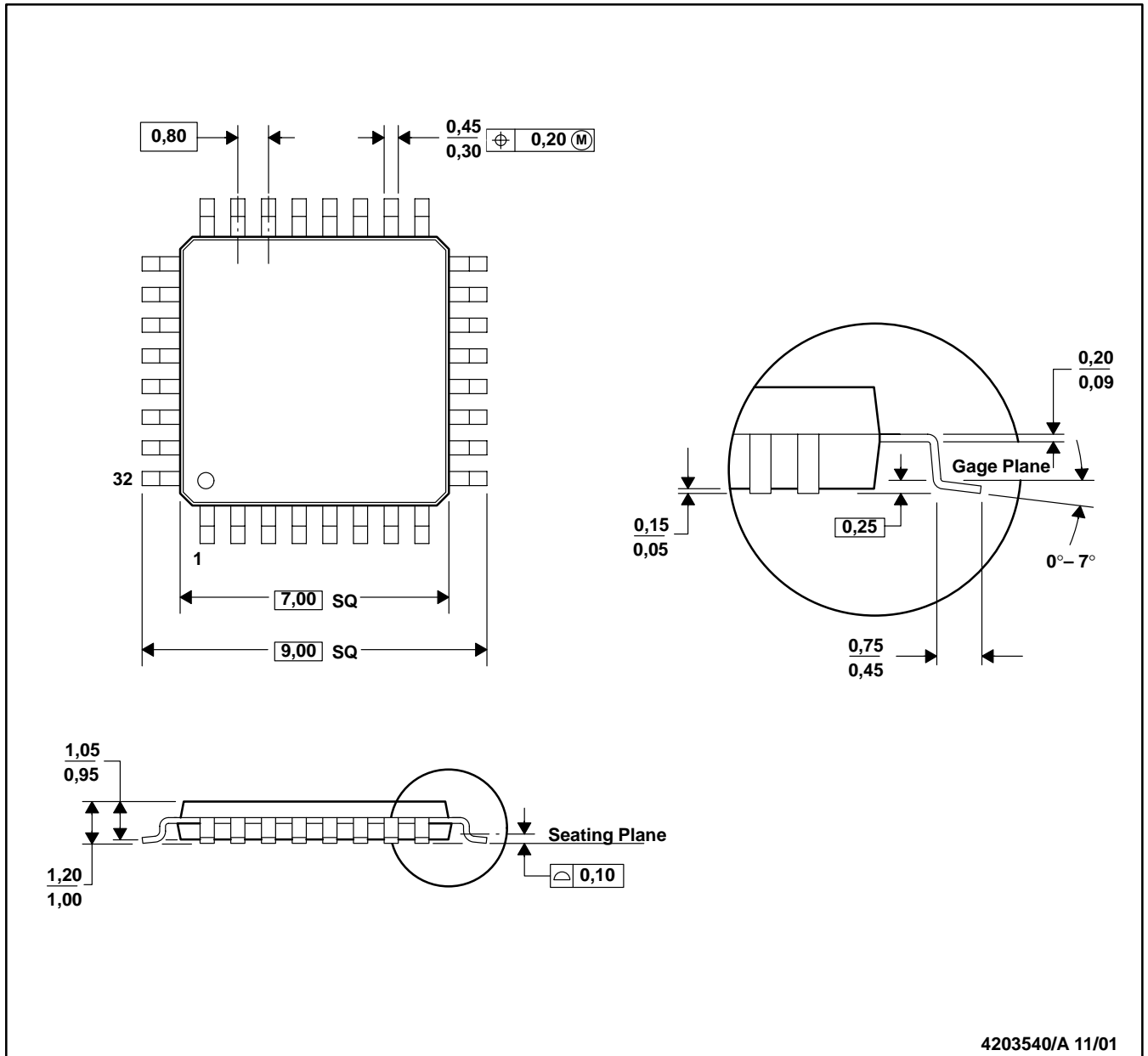

- NOTES: A. All linear dimensions are in millimeters.  
 B. This drawing is subject to change without notice.  
 C. Falls within JEDEC MS-026

## IMPORTANT NOTICE AND DISCLAIMER

TI PROVIDES TECHNICAL AND RELIABILITY DATA (INCLUDING DATASHEETS), DESIGN RESOURCES (INCLUDING REFERENCE DESIGNS), APPLICATION OR OTHER DESIGN ADVICE, WEB TOOLS, SAFETY INFORMATION, AND OTHER RESOURCES "AS IS" AND WITH ALL FAULTS, AND DISCLAIMS ALL WARRANTIES, EXPRESS AND IMPLIED, INCLUDING WITHOUT LIMITATION ANY IMPLIED WARRANTIES OF MERCHANTABILITY, FITNESS FOR A PARTICULAR PURPOSE OR NON-INFRINGEMENT OF THIRD PARTY INTELLECTUAL PROPERTY RIGHTS.

These resources are intended for skilled developers designing with TI products. You are solely responsible for (1) selecting the appropriate TI products for your application, (2) designing, validating and testing your application, and (3) ensuring your application meets applicable standards, and any other safety, security, or other requirements. These resources are subject to change without notice. TI grants you permission to use these resources only for development of an application that uses the TI products described in the resource. Other reproduction and display of these resources is prohibited. No license is granted to any other TI intellectual property right or to any third party intellectual property right. TI disclaims responsibility for, and you will fully indemnify TI and its representatives against, any claims, damages, costs, losses, and liabilities arising out of your use of these resources.

TI's products are provided subject to TI's Terms of Sale ([www.ti.com/legal/termsofsale.html](http://www.ti.com/legal/termsofsale.html)) or other applicable terms available either on [ti.com](http://ti.com) or provided in conjunction with such TI products. TI's provision of these resources does not expand or otherwise alter TI's applicable warranties or warranty disclaimers for TI products.

Mailing Address: Texas Instruments, Post Office Box 655303, Dallas, Texas 75265  
Copyright © 2019, Texas Instruments Incorporated

## Looking for pricing, stock, or lifecycle information?

Click below to explore more details on WIN SOURCE:

 [View PCM2707CPJT](#) on WIN SOURCE

 [Texas Instruments](#) Information

## Optimize Your Supply Chain with WIN SOURCE Solutions

-  Global Sourcing Solution
-  Obsolete Management
-  Cost Control Management
-  Shortage Management
-  Alternative Solution
-  Excess Inventory Management