

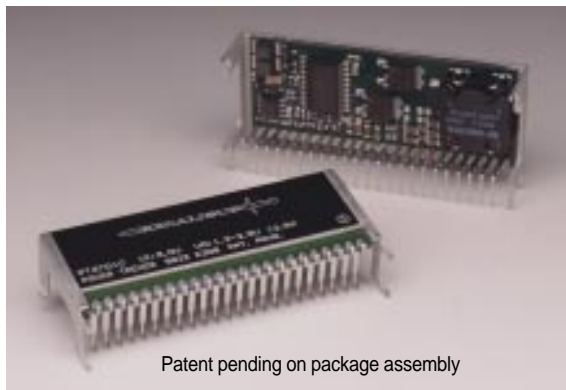

**THE DATASHEET OF
PT6721C**





Patent pending on package assembly

- +12V input
- 5-bit Programmable: 1.3V to 3.5V@14A
- High Efficiency
- Input Voltage Range: 10.8V to 13.2V
- Differential Remote Sense
- 23-pin Space Saving Package
- Solderable Copper Case
- Short Circuit Protection
- Over-Voltage Drive
- Power Good Signal

The PT6721 is a new high-performance, 14 Amp Integrated Switching Regulators (ISRs) housed in a unique, 23-pin space-saving package. The PT6721 operates from a standard 12V power bus to provide a high performance low-voltage power source for the industry's latest high-speed, low-voltage μ Ps and bus drivers. The output voltage of the PT6721 can be easily programmed from 1.3V to 3.5V with a 5-bit input compatible with Intel's Pentium[®] Processor family.

Standard Application

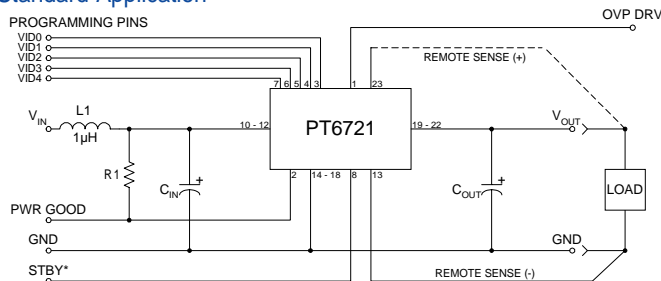

- C_{in} = Required 1000 μ F electrolytic (See footnotes)
- C_{out} = Required 330 μ F electrolytic (See footnotes)
- L1 = Optional 1 μ H input choke (See footnotes)
- R1 = Required 10k Ω pull-up when using Pwr Good signal. Pwr good output is high when the output voltage is within specification.

PT6700 Product Family

	Input Voltage	Vout Adjust	OVP/ PWRGD	Needs 12VBias
PT6701	5V	VID	✓	
PT6702	3.3V	VID	✓	
PT6705	5V	Resistor		✓
PT6715	5V	Resistor		
PT6721	12V	VID	✓	
PT6725	12V	Resistor		

Specifications

Characteristics ($T_a = 25^\circ\text{C}$ unless noted)	Symbols	Conditions	PT6721 SERIES				
			Min	Typ	Max	Units	
Output Current	I_o	$T_a = +60^\circ\text{C}$, 200 LFM, pkg N $T_a = +25^\circ\text{C}$, natural convection	0.1 (1) 0.1 (1)	—	14 14	A	
Input Voltage Range	V_{in}	$0.1A \leq I_o \leq 14A$	10.8	—	13.2	V	
Output Voltage Tolerance	ΔV_o	$V_{in} = +12V$, $I_o = 14A$ $-40^\circ\text{C} \leq T_a \leq +85^\circ\text{C}$	$V_o - 0.03$	—	$V_o + 0.03$	V	
Short-Circuit Threshold	I_{sc}	$V_{in} = +12V$	—	20	30	A	
Line Regulation	Reg_{line}	$10.8V \leq V_{in} \leq 13.2V$, $I_o = 14A$	—	± 5	—	mV	
Load Regulation	Reg_{load}	$V_{in} = +12V$, $0.1 \leq I_o \leq 14A$	—	± 10	—	mV	
V_o Ripple/Noise	V_n	$V_{in} = +12V$, $I_o = 14A$	—	35	—	mV	
Transient Response with $C_{out} = 330\mu\text{F}$	t_{tr} V_{os}	I_o step between 7A and 14A V_o over/undershoot	—	50 70	—	μSec mV	
Efficiency	η	$V_{in} = +12V$, $I_o = 9A$	$V_o = 3.3V$ $V_o = 2.5V$ $V_o = 1.8V$ $V_o = 1.5V$	— — — —	90 88 83 81	— — — —	%
Switching Frequency	f_o	$10.8V \leq V_{in} \leq 13.2V$ $0.1A \leq I_o \leq 14.0A$	300	350	400	kHz	
Absolute Maximum Operating Temperature Range	T_a	—	-40 (2)	—	+85 (3)	$^\circ\text{C}$	
Storage Temperature	T_s	—	-40	—	+125	$^\circ\text{C}$	
Mechanical Shock		Per Mil-STD-883D, Method 2002.3 1 msec, Half Sine, mounted to a fixture	—	500	—	G's	
Mechanical Vibration		Per Mil-STD-883D, Method 2007.2, 20-2000 Hz, Soldered in a PC board	—	15	—	G's	
Weight	—	—	—	26	—	grams	

- Notes: (1) ISR-will operate down to no load with reduced specifications.
 (2) For operation below 0°C , C_{in} and C_{out} must have stable characteristics. Use either low ESR tantalum or Oscon[®] capacitors.
 (3) See Safe Operating Area curves, or contact the factory for appropriate derating.
 (4) If the Remote Sense Ground is not used, pin 13 must be connected to pin 14 for optimum output voltage accuracy.

External Capacitors: The PT6721 requires a minimum output capacitance of 330 μF , with a maximum ESR of 50m Ω @100kHz for proper operation. The maximum allowable output capacitance is 15,000 μF . The input capacitance must be rated for a minimum of 1.6Arms of ripple current. For transient or dynamic load applications, additional capacitance may be required. For more information refer to the application note regarding capacitor selection for this product.

Input Filter: An input filter inductor is optional for most applications. The inductor must be sized to handle 5ADC with a typical value of 1 μH .

PT6721—12V

14 Amp Programmable Integrated Switching Regulator

Pin-Out Information

Pin	Function	Pin	Function
1	OVP Drive	13	Remote Sense Gnd (4)
2	Pwr Good	14	GND
3	VID0	15	GND
4	VID1	16	GND
5	VID2	17	GND
6	VID3	18	GND
7	VID4	19	V _{out}
8	STBY#	20	V _{out}
9	Do not connect	21	V _{out}
10	V _{in}	22	V _{out}
11	V _{in}	23	Remote Sense V _{out}
12	V _{in}		

#For STBY pin:-
 open =output enabled
 ground =output disabled.

Programming Information

VID3	VID2	VID1	VID0	VID4=1 V _{out}	VID4=0 V _{out}
1	1	1	1	2.0V	1.30V
1	1	1	0	2.1V	1.35V
1	1	0	1	2.2V	1.40V
1	1	0	0	2.3V	1.45V
1	0	1	1	2.4V	1.50V
1	0	1	0	2.5V	1.55V
1	0	0	1	2.6V	1.60V
1	0	0	0	2.7V	1.65V
0	1	1	1	2.8V	1.70V
0	1	1	0	2.9V	1.75V
0	1	0	1	3.0V	1.80V
0	1	0	0	3.1V	1.85V
0	0	1	1	3.2V	1.90V
0	0	1	0	3.3V	1.95V
0	0	0	1	3.4V	2.00V
0	0	0	0	3.5V	2.05V

Logic 0 = Pin 13 potential (remote sense gnd)
 Logic 1 = Open circuit (no pull-up resistors)
 VID3 and VID4 may not be changed while the unit is operating.

Ordering Information

PT6721□ = 1.3 to 3.5 Volts
 (For dimensions and PC board layout, see Package Styles 1300 and 1310.)

PT Series Suffix (PT1234X)

Case/Pin Configuration	
Vertical Through-Hole	N
Horizontal Through-Hole	A
Horizontal Surface Mount	C

TYPICAL CHARACTERISTICS

12.0V Input Voltage (Note A)

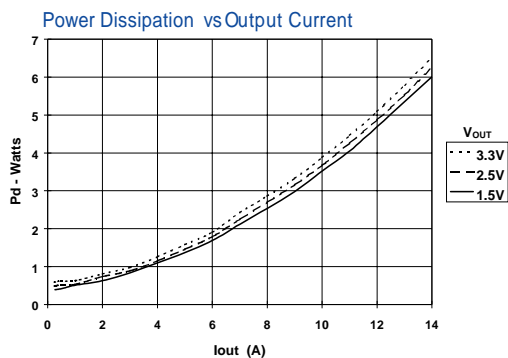
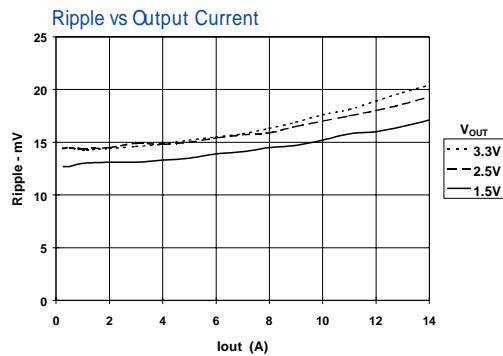
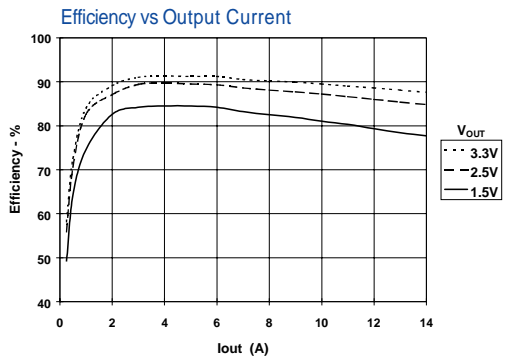

Safe Operating Area Curves (Note B)

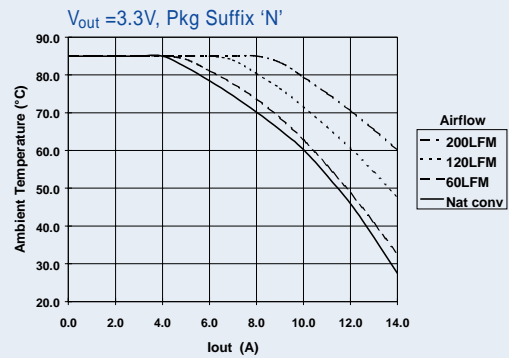

Note: A All data listed in the above graphs has been developed from actual products tested at 25°C. This data is considered typical data for the ISR.
 Note: B SOA Curves represent the conditions at which internal components are at or below manufacturer's maximum operating temperatures.

PT6701/PT6702/PT6721

Operating Features of the Programmable PT6700 "Excalibur™" Series ISRs

Power Good

Programmable versions of the PT6700 Series regulators incorporate a *PWR Good* output (pin 2). This output is open-drain and generates an active-high signal when the sensed output from the ISR is within a nominal $\pm 10\%$ of the programmed set point. When the regulated output is outside this range, pin 2 asserts a logic low (typically $< 0.1V$). A $10k\Omega$ pull-up resistor to a valid bus voltage is required. If the power good feature is not used, the pull-up resistor can be omitted. The maximum voltage that may be applied to the pull-up resistor is 15V.

Over-Voltage Protection (OVP)

The PT6700 programmable regulators also incorporate an OVP function. The *OVP DRV* (pin 1) normally has a logic low output (typically $< 0.1V$). When the ISR's sensed output exceeds the programmed output setting by 15%, pin 1 produces a 60mA, +12V drive signal. This drive signal can trigger an SCR, which can be used to disable the input voltage, or alternatively interface to another external monitoring device. When the ISR output voltage returns to within 15% of its programmed setting, pin 1 reverts back to its low state. If the OVP function is not used, pin 1 may be left open circuit.

Stand-By Function

The PT6700 series ISRs incorporate a standby function. This feature may be used for power-up sequencing, or wherever there is a requirement for the output voltage to be controlled by external circuitry.

If the *STBY** input (pin 8) is left open-circuit the regulator operates normally, providing a regulated output when a valid supply voltage is applied to V_{in} (pins 10-12) with respect to GND (pins 14-18). Connecting pin 8 to ground¹ places the regulator in standby mode, and reduces the input current to typically 20mA (30mA max). Applying a ground signal to pin 8 prior to power-up, will disable the output during the period that input power is applied. To ensure that the regulator output is fully enabled, pin 8 must be allowed to rise to a minimum of 3.0V.

Notes:

1. The standby on the PT6700 series is ideally controlled with an open-collector (or open-drain) discrete transistor (See fig. 1). Table 1 gives the threshold requirements. *Do Not* use a pull-up resistor. The control input has an open-circuit voltage of about 4.0Vdc. To set the regulator output to zero, the control pin must be "pulled" to less than 1.0Vdc with a sink to ground.

2. The Standby input can also be interfaced to TTL or other bi-directional output device using a schottky diode. See Figure 1.
3. When placed in the standby mode, the regulator output may assert a low impedance to ground. If an external voltage is applied to the output, it will sink current and possibly over-stress the part.

Table 1 Inhibit Control Threshold^{2,3}

Parameter	Min	Typ	Max
Enable (V_{IH})	3.0V		
Disable (V_{IL})	-0.1V	0.4V	1.0V
I_{stby}		0.01mA	

Figure 1

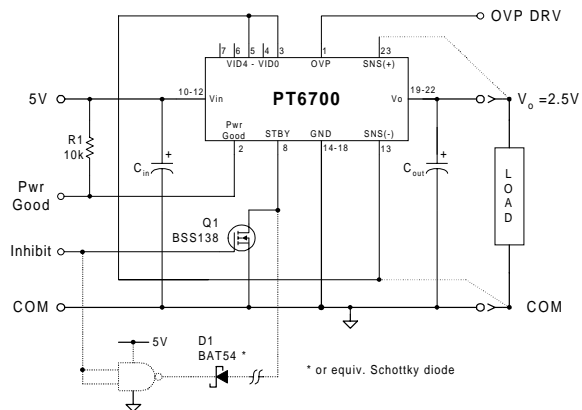

Turn-On Time

Turning Q_1 in Figure 1 off, removes the low-voltage signal at pin 8 and enables the output. Following a brief delay of 10-15ms, the output voltage of the PT6700 regulator rises to full regulation within 30ms. Figure 2 shows the typical output voltage waveform of a PT6701 following the prompt turn-off of Q_1 at time $t = 0$ secs. The output voltage was set to 2.5V. The waveforms were measured with a 5V input source voltage, and 10A resistive load.

Figure 2

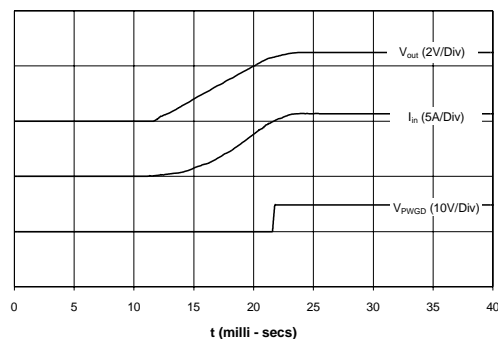

Pin-Coded Output Voltage Adjustment on Non-Isolated “Excalibur™” Series ISRs

The PT6701/6702/6721 Excalibur™ ISRs incorporate a pin-coded voltage control to adjust the output voltage. The control pins are identified VID0 - VID4 (pins 3-7) respectively. When these control pins are left open-circuit the ISR output will regulate at its factory trimmed output voltage. Each pin is internally connected to a precision resistor, which when grounded changes the output voltage by a set amount. By selectively grounding VID0-VID4, the output voltage these ISRs can be programmed in incremental steps over the specified output voltage range. The program code and output voltage range of these ISRs is compatible with the voltage ID specification defined by Intel Corporation. The code is used in conjunction with voltage regulator modules (VRMs) that are used to power Intel's Pentium® microprocessors. Refer to Figure 1 below for the connection schematic, and the respective device Data Sheet for the appropriate programming code information.

Notes:

- The programming convention is as follows:-
 - Logic 0: Connect to pin13 (Remote Sense Ground).
 - Logic 1: Open circuit/open drain (See notes 2, & 4)
- Do not connect pull-up resistors to the voltage programming pins.
- To minimize output voltage error, always use pin 13 (Remote Sense Ground) as the logic “0” reference. While the regular ground (pins 14-18) can also be used for programming, doing so will degrade the load regulation of the product.

- If active devices are used to ground the voltage control pins, low-level open drain MOSFET devices should be used over bipolar transistors. The inherent $V_{ce(sat)}$ in bipolar devices introduces errors in the device's internal voltage control circuit. Discrete transistors such as the BSS138, 2N7002, IRLML2402, or the 74C906 hex open-drain buffer are examples of appropriate devices.

Active Voltage Programming:

Special precautions should be taken when making changes to the voltage control program code while the unit is powered. It is highly recommended that the ISR be either powered down or held in standby. Changes made to the program code while V_{out} is enabled induces high current transients through the device. This is the result of the electrolytic output capacitors being either charged or discharged to the new output voltage set-point. The transient current can be minimized by making only incremental changes to the binary code, i.e. one LSB at a time. A minimum of 100 μ s settling time between each program state is also recommended. Making non-incremental changes to VID3 and VID4 with the output enabled is discouraged. If they are changed, the transients induced can overstress the device resulting in a permanent drop in efficiency. If the use of active devices prevents the program code being asserted prior to power-up, pull pin 8 (STBY) to the device GND during the period that the input voltage is applied to V_{in} . Releasing pin 8 will then allow the device output to initiate a soft-start power-up to the programmed voltage.

Figure 1

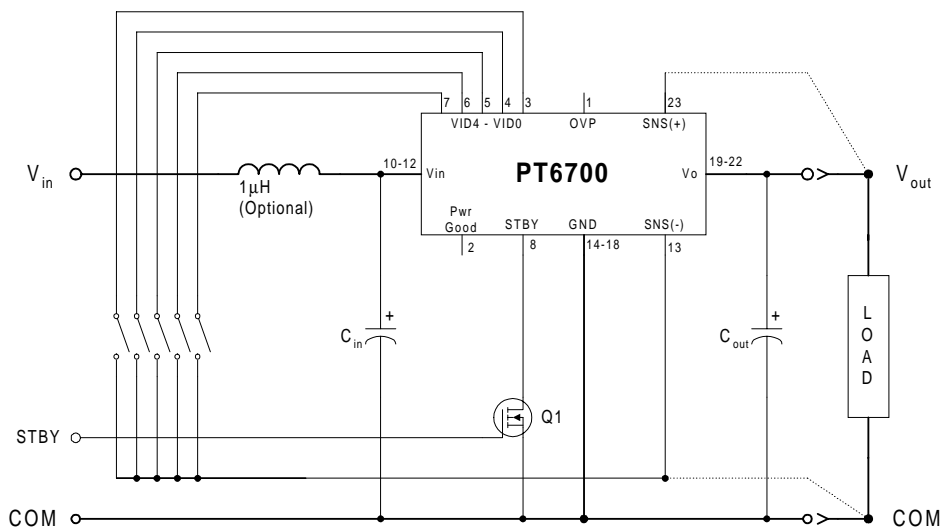

PT6721/6725 Series

Capacitor Recommendations for the PT6721 and PT6725 Series Regulators

Input Capacitors

The recommended input capacitance is determined by 1.6 ampere minimum ripple current rating and 1000µF minimum capacitance. Tantalum capacitors listed below cannot be used on the input bus since they are not rated for 12V operation. Ripple current and Equivalent Series Resistance (ESR) values are the major considerations along with temperature when selecting the proper capacitor.

Output Capacitors

The minimum required output capacitance is 330µF with a maximum ESR less than or equal to 50mΩ. Failure to observe this requirement may lead to regulator instability or oscillation. Electrolytic capacitors have poor ripple performance at frequencies greater than 400kHz, but excellent low frequency transient response. Above the ripple frequency ceramic decoupling capacitors are necessary to improve the transient response and reduce any microprocessor high frequency noise components apparent during higher current excursions. Preferred low ESR type capacitor part numbers are identified in the Table 1 below.

Tantalum Characteristics

Tantalum capacitors are recommended on the output bus but only TPS Series, Sprague 593D/594/595 Series, or Kemet T495/T510 Series. The AVX TPS Series, Sprague Series or Kemet Series tantalum capacitors are recommended over other manufacturer's due to their higher surge current, excellent power dissipation and ripple current ratings. As an example, the TAJ Series by AVX is not recommended. This series exhibits considerably higher ESR, reduced power dissipation and lower ripple current capability. The TAJ Series is a less reliable compared to the TPS series when comparing power dissipation capability.

Capacitor Table

Table 1 identifies the characteristics of capacitors from a number of vendors with acceptable ESR and ripple current (rms) ratings. The suggested minimum quantities per regulator for both the input and output buses are identified.

This is not an extensive capacitor list. The table below is a selection guide for input and output capacitors. Other capacitor vendors are available with comparable RMS ripple current rating and ESR (Equivalent Series Resistance at 100kHz). These critical parameters are necessary to insure both optimum regulator performance and long capacitor life.

Table 1 Capacitors Characteristic Data

Capacitor Vendor/ Series	Capacitor Characteristics					Quantity		Vendor Number
	Working Voltage	Value(µF)	(ESR) Equivalent Series Resistance	105°C Maximum Ripple Current(Irms)	Physical Size(mm)	Input Bus	Output Bus	
Panasonic FC Series FA Series	35V	680	0.043Ω	1655mA	12.5x20	2	1	EEUFC1V681 EEUFC1E102 EEUFC1E102S
	25V	1000	0.038Ω	1655mA	12.5x20	1	2	
	25V	1000	0.038Ω	1690mA	16x15	1	1	
United Chem -con LFV Series	35V	680	0.034Ω	1690mA	12.5x25	2	1	LXV35VB680M12X25LL LXV35VB102M16X20LL LXV16VB471M10X16LL
	35V	1000	0.038Ω	1630mA	16x20	1	1	
	16V	470	0.084Ω/2=0.42Ω	825mA x2	10x16	N/R(1)	2	
Nichicon PL Series PM Series	35V	680	0.036Ω	1660mA	12.5x25	2	1	UPL1V681MHH UPL1E122MHH6 UPM1V102MHH6
	25V	1200	0.039Ω	1600mA	18x15	1	1	
	35V	1000	0.034Ω	1770mA	16x20	1	1	
Panasonic FC Series Surface Mtg	35V	1000	0.038Ω	2000mA	18x16.5	1	1	EEVFC1V102N EEVFC1E102N EEVFC1V471N
	25V	1000	0.038Ω	2000mA	18x16.5	1	1	
	35V	470	0.0430Ω	1690mA	16x16.5	2	1	
Oscon- SS/SV Series	10V	330	0.025Ω	3500mA	10x10.5	N/R(1)	1	10SS330M(If Output <5V) 10SV330(If Output <5V) Surface Mount(SV)
	10V	330	0.020Ω	3800mA	10.3x10.3	N/R(1)	1	
AVX Tantalum TPS Series	10V	330	0.100Ω/2=0.050Ω	>2500mA	7.3L x 5.7W x 4.1H	N/R(1)	2	TPSE337M010R0100 TPSV337M010R0060 Surface Mount
	10V	330	0.060Ω/2=0.030Ω	>3000mA		N/R(1)	2	
Kemet Tantalum T510/T495 Series	10V	330	0.033Ω	1400mA	4.3Wx7.3L x4.0H	N/R(1)	1	510X337M010AS T495X227M0100AS Surface Mount
	10V	220	0.070Ω/2=0.035Ω	>2000mA		N/R(1)	2	
Sprague Tantalum 594D Series	10V	330	0.045Ω	2360mA	7.2L x 6W x 4.1H	N/R(1)	1	594D337X0010R2T Surface Mount

Note: (N/R) 10V tantalums are not recommend for the input bus.

IMPORTANT NOTICE

Texas Instruments and its subsidiaries (TI) reserve the right to make changes to their products or to discontinue any product or service without notice, and advise customers to obtain the latest version of relevant information to verify, before placing orders, that information being relied on is current and complete. All products are sold subject to the terms and conditions of sale supplied at the time of order acknowledgment, including those pertaining to warranty, patent infringement, and limitation of liability.

TI warrants performance of its semiconductor products to the specifications applicable at the time of sale in accordance with TI's standard warranty. Testing and other quality control techniques are utilized to the extent TI deems necessary to support this warranty. Specific testing of all parameters of each device is not necessarily performed, except those mandated by government requirements.

Customers are responsible for their applications using TI components.

In order to minimize risks associated with the customer's applications, adequate design and operating safeguards must be provided by the customer to minimize inherent or procedural hazards.

TI assumes no liability for applications assistance or customer product design. TI does not warrant or represent that any license, either express or implied, is granted under any patent right, copyright, mask work right, or other intellectual property right of TI covering or relating to any combination, machine, or process in which such semiconductor products or services might be or are used. TI's publication of information regarding any third party's products or services does not constitute TI's approval, warranty or endorsement thereof.

Looking for pricing, stock, or lifecycle information?

Click below to explore more details on WIN SOURCE:

 [View PT6721C on WIN SOURCE](#)

 [Texas Instruments](#) Information

Optimize Your Supply Chain with WIN SOURCE Solutions

-  Global Sourcing Solution
-  Obsolete Management
-  Cost Control Management
-  Shortage Management
-  Alternative Solution
-  Excess Inventory Management