

- Dual Outputs:
+3.3V/6A
+2.5V/2.2A or +1.8V/1.5A
- Adjustable Output Voltage
- Remote Sense (both outputs)
- Standby Function
- Over-Temperature Protection
- Soft-Start
- Internal Sequencing
- 23-pin SIPPackage

The PT6920 is a series of 25W dual output ISRs that were purposely designed to power the latest generation DSP chips. Both output voltages are independently adjustable, allowing either output voltages to be changed to accommodate a DSP upgrade. The internal power sequencing of both outputs meet the requirements of TI's 'C6000 series DSPs.

Patent Pending*

Standard Application

C₁ = Req'd 560µF electrolytic (1)
C₂ = Req'd 330µF electrolytic (1)
C₃ = Optional 100µF electrolytic

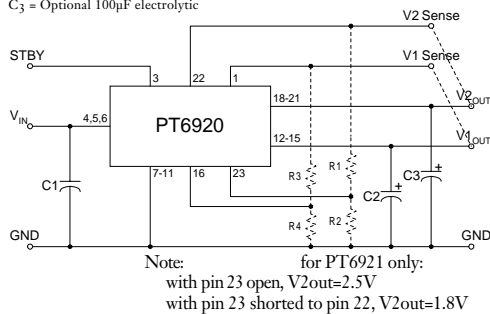

Pin-Out Information

Pin	Function	Pin	Function
1	V ₁ Remote Sense	13	V _{1out}
2	Do Not Connect	14	V _{1out}
3	STBY	15	V _{1out}
4	V _{in}	16	V ₁ Adjust
5	V _{in}	17	Do Not Connect
6	V _{in}	18	V _{2out}
7	GND	19	V _{2out}
8	GND	20	V _{2out}
9	GND	21	V _{2out}
10	GND	22	V ₂ Remote Sense
11	GND	23	V ₂ Adjust*
12	V _{1out}		

Ordering Information

PT6921□ = +3.3 Volts
+2.5/+1.8 Volts
PT6922□ = +3.3 Volts
+1.5 Volts

PT Series Suffix (PT1234X)

Case/Pin Configuration

Vertical Through-Hole	N
Horizontal Through-Hole	A
Horizontal Surface Mount	C

(For dimensions and PC board layout, see Package Styles 1100 and 1110.)

Specifications

Characteristics (T _a = 25°C unless noted)	Symbols	Conditions	PT6920 SERIES			Units	
			Min	Typ	Max		
Output Current	I _o	T _a = +60°C, 200 LFM, pkg N	V ₁ = 3.3V	0.1 (2)	—	5.5 (3)	A
			V ₂ = 2.5V	0	—	2.2 (3)	
			V ₂ = 1.8V	0	—	1.75(3)	
		T _a = +25°C, natural convection	V ₁ = 3.3V	0.1	—	6.0	
			V ₂ = 2.5V	0	—	2.2	
			V ₂ = 1.8V	0	—	1.75	
Input Voltage Range	V _{in}	0.1A ≤ I _o ≤ I _{max}	4.5	—	5.5	V	
			Output Voltage Tolerance	ΔV _o	V _{in} = +5V, I _o = I _{max} , both outputs 0°C ≤ T _a ≤ +65°C	V _o -0.1	—
Line Regulation	Reg _{line}	4.5V ≤ V _{in} ≤ 5.5V, I _o = I _{max}	V ₁ = 3.3V	—	±7	±17	mV
			V ₂ = 2.5V	—	±7	±13	
Load Regulation	Reg _{load}	V _{in} = +5V, 0.1 ≤ I _o ≤ I _{max}	V ₁ = 3.3V	—	±17	±33	mV
			V ₂ = 2.5V	—	±4	±10	
V _o Ripple/Noise	V _n	V _{in} = +5V, I _o = I _{max}	V ₁ = 3.3V	—	50	—	mV
			V ₂ = 2.5V	—	25	—	
Transient Response with C ₂ = 330µF	t _{tr} V _{os}	I _o step between 0.5xI _{max} and I _{max} V _o over/undershoot	V ₁ = 3.3V	—	25	—	µSec
			V ₂ = 2.5V	—	60	—	
Efficiency	η	V _{in} = +5V, I _o = 4A total	—	75	—	%	
Switching Frequency	f _o	4.5V ≤ V _{in} ≤ 5.5V	475	600	725	kHz	
		0.1A ≤ I _o ≤ I _{max}	—	—	—		
Absolute Maximum Operating Temperature Range	T _a	Over V _{in} Range	-40 (4)	—	+85 (5)	°C	
			Storage Temperature	T _s	—		-40
Weight	—	Vertical/Horizontal	—	29	—	grams	

- Notes:** (1) The PT6920 series requires a 560µF electrolytic capacitor on the input and a 330µF electrolytic capacitor on the output for proper operation in all applications.
(2) I_{gmin} current of 0.1A can be divided between both outputs; V₁, or V₂. The ISR will operate down to no-load with reduced specifications.
(3) I_{gmax} listed for each output assumes the maximum current drawn simultaneously on both outputs. Consult the factory for the absolute maximum.
(4) For operating temperatures below 0°C, use tantalum type capacitors on both the input and output.
(5) See Safe Operating Area curves for appropriate derating.

25 Watt 5V Input Dual Output
Integrated Switching Regulator

PT6921, $V_{2out} = 2.5V$, $I_{2out} = 2.2A$ (See Note A)

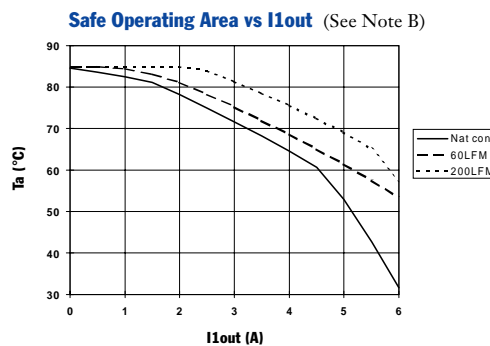
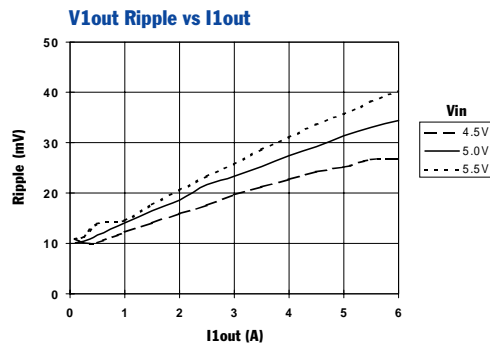
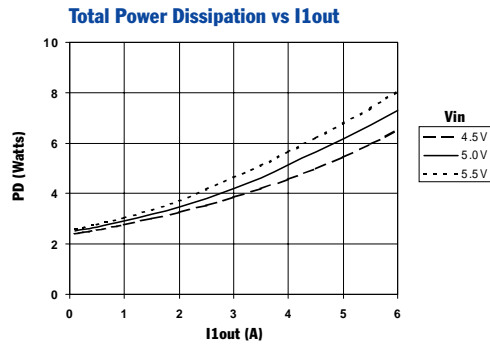
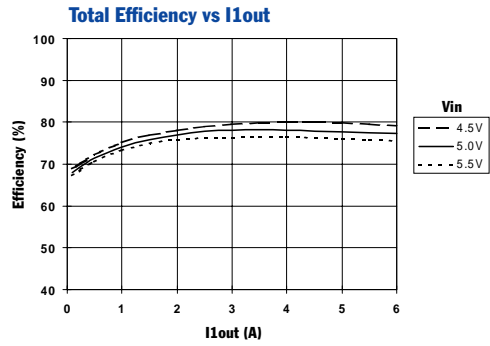

Note A: All characteristic data listed in the above graphs has been developed from actual products tested at 25°C. This data is considered typical data for the ISR.
Note B: SOA curves represent operating conditions at which internal components are at or below manufacturer's maximum rated operating conditions.

PT6920/PT6930 Series

Adjusting the Output Voltage of the PT6920 and PT6930 Dual Output Voltage ISRs

Each output voltage from the PT6920 and PT6930 series of ISRs can be independently adjusted higher or lower than the factory trimmed pre-set voltage. V_1 (the voltage at V_{1out}), or V_2 (the voltage at V_{2out}) may each be adjusted either up or down using a single external resistor². Table 1 gives the adjustment range for both V_1 and V_2 for each model in the series as V_a (min) and V_a (max). Note that V_2 must always be lower than V_1 ³.

V_1 Adjust Up: To increase the output, add a resistor R4 between pin 16 (V_1 Adjust) and pins 7-11 (GND)².

V_1 Adjust Down: Add a resistor (R3), between pin 16 (V_1 Adjust) and pin 1 (V_1 Remote Sense)².

V_2 Adjust Up: Add a resistor R2 between pin 23 (V_2 Adjust) and pins 7-11 (GND)².

V_2 Adjust Down: Add a resistor (R1) between pin 23 (V_2 Adjust) and pin 22 (V_2 Remote Sense)².

Refer to Figure 1 and Table 2 for both the placement and value of the required resistor.

Notes:

1. The output voltages, V_{1out} and V_{2out} , may be adjusted independently.
2. Use only a single 1% resistor in either the (R3) or R4 location to adjust V_1 , and in the (R1) or R2 location to adjust V_2 . Place the resistor as close to the ISR as possible.
3. V_2 must always be at least 0.2V lower than V_1 .
4. V_2 on both the PT6921 and PT6931 models may be adjusted from 2.5V to 1.8V by simply connecting pin 22 (V_2 Remote Sense) to pin 23 (V_2 Adjust). For more details, consult the data sheet.

5. If V_1 is increased above 3.3V, the minimum input voltage to the ISR must also be increased. The minimum required input voltage must be $(V_1 + 1.2)V$ or 4.5V, whichever is greater. Do not exceed 5.5V
6. Never connect capacitors to either the V_1 Adjust or V_2 Adjust pins. Any capacitance added to these control pins will affect the stability of the respective regulated output.
7. Adjusting either voltage (V_1 or V_2) may increase the power dissipation in the regulator, and correspondingly change the maximum current available at either output. Consult the factory for application assistance.

The adjust up and adjust down resistor values can also be calculated using the following formulas. Be sure to select the correct formula parameter from Table 1 for the output and model being adjusted.

$$(R1) \text{ or } (R3) = \frac{R_o (V_a - 1)}{V_o - V_a} - R_s \quad \text{k}\Omega$$

$$R2 \text{ or } R4 = \frac{R_o}{V_a - V_o} - R_s \quad \text{k}\Omega$$

Where: V_o = Original output voltage, (V_1 or V_2)
 V_a = Adjusted output voltage
 R_o = The resistance value from Table 1
 R_s = The series resistance from Table 1

Table 1

PT6920 ADJUSTMENT RANGE AND FORMULA PARAMETERS			
Output Bus	V_1 out	V_2 out	
Series Pt #			
Standard Case	PT6921/22	PT6921	PT6922
Excalibur Case	PT6931/32	PT6931	PT6932
Adj. Resistor	(R3)/R4	(R1)/R2	(R1)/R2
V_o (nom)	3.3V	2.5V	1.5
V_a (min)	2.3V	1.8V	1.2
V_a (max)	3.6V	3.0V	3.0
R_o (k Ω)	12.1	10.0	9.76
R_s (k Ω)	12.1	11.5	6.49

Figure 1

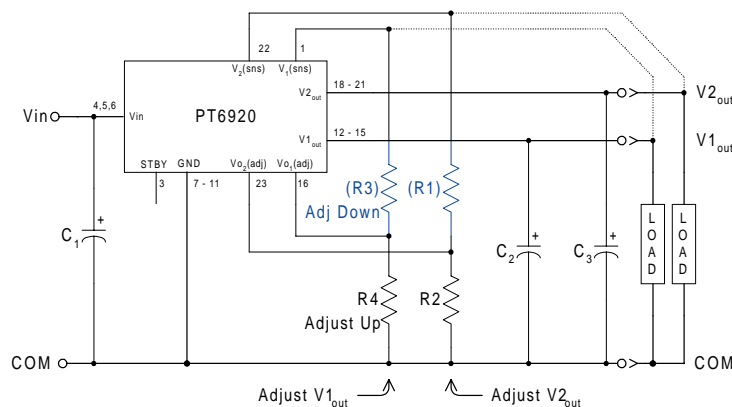

PT6920/PT6930 Series

Table 2

PT6920/PT6930 ADJUSTMENT RESISTOR VALUES			
Output Bus	V ₁ out	V ₂ out	
Series Pt#			
Standard Case	PT6921/6922	PT6921	PT6922
Excalibur Case	PT6931/6932	PT6931	PT6932
Adj Resistor	(R3)/R4	(R1)/R2	(R1)/R2
V _o (nom)	3.3Vdc	2.5Vdc	1.5Vdc
V _a (req'd)			
1.2			(0.0)kΩ
1.25			(3.3)kΩ
1.3			(8.2)kΩ
1.35			(16.3)kΩ
1.4			(32.6)kΩ
1.45			(81.4)kΩ
1.5			
1.55			189.0kΩ
1.6			91.1kΩ
1.65			58.6kΩ
1.7			42.3kΩ
1.75			32.6kΩ
1.8		(0.0)kΩ	26.0kΩ
1.85		(1.6)kΩ	21.4kΩ
1.9		(3.5)kΩ	17.9kΩ
1.95		(5.8)kΩ	15.2kΩ
2.0		(8.5)kΩ	13.0kΩ
2.05		(11.8)kΩ	11.3kΩ
2.1		(16.0)kΩ	9.8kΩ
2.15		(21.4)kΩ	8.5kΩ
2.2		(28.5)kΩ	7.5kΩ
2.25		(38.5)kΩ	6.5kΩ
2.3	(3.6)kΩ	(53.5)kΩ	5.7kΩ
2.35	(5.1)kΩ	(78.5)kΩ	5.0kΩ
2.4	(6.7)kΩ	(129.0)kΩ	4.4kΩ
2.45	(8.5)kΩ	(279.0)kΩ	3.8kΩ
2.5	(10.6)kΩ		3.3kΩ
2.55	(12.9)kΩ	189.0kΩ	2.8kΩ
2.6	(15.6)kΩ	88.5kΩ	2.4kΩ
2.65	(18.6)kΩ	55.2kΩ	2.0kΩ
2.7	(22.2)kΩ See Note 3	38.5kΩ	1.6kΩ
2.75	(26.4)kΩ	28.5kΩ	1.3kΩ
2.8	(31.5)kΩ	21.8kΩ	1.0kΩ
2.85	(37.6)kΩ	17.1kΩ	0.7kΩ
2.9	(45.4)kΩ	13.5kΩ	0.5kΩ
2.95	(55.3)kΩ	10.7kΩ	0.2kΩ
3.0	(68.6)kΩ	8.5kΩ	0.0kΩ
3.05	(87.1)kΩ		
3.1	(115.0)kΩ		
3.15	(161.0)kΩ		
3.2	(254.0)kΩ		
3.25	(532.0)kΩ		
3.3			
3.4	109.0kΩ See Note 5		
3.5	48.4kΩ		
3.6	28.2kΩ		

R1/R3 = (Blue) R2/R4 = Black

PT6920/PT6930 Series

Using the Standby Function on the PT6920 and PT6930 Dual Output Voltage Converters

Both output voltages of the 23-pin PT6920/6930 dual output converter may be disabled using the regulator's standby function. This function may be used in applications that require power-up/shutdown sequencing, or wherever there is a requirement to control the output voltage On/Off status with external circuitry.

The standby function is provided by the *STBY** control, pin 3. If pin 3 is left open-circuit the regulator operates normally, and provides a regulated output at both $V_{1,out}$ (pins 12–15) and $V_{2,out}$ (pins 18–21) whenever a valid supply voltage is applied to V_{in} (pins 4, 5, & 6) with respect to GND (pins 7–11). If a low voltage² is then applied to pin-3 both regulator outputs will be simultaneously disabled and the input current drawn by the ISR will typically drop to less than 30mA (50mA max). The standby control may also be used to hold-off both regulator outputs during the period that input power is applied.

The standby pin is ideally controlled using an open-collector (or open-drain) discrete transistor (See Figure 1). It may also be driven directly from a dedicated TTL³ compatible gate. Table 1 provides details of the threshold requirements.

Table 1 Inhibit Control Thresholds^{2,3}

Parameter	Min	Max
Enable (V_{IH})	1.8V	V_{in}
Disable (V_{IL})	-0.1V	0.8V

Notes:

1. The Standby/Inhibit control logic is similar for all Power Trends' modules, but the flexibility and threshold tolerances will be different. For specific information on this function for other regulator models, consult the applicable application note.
2. The Standby control pin is ideally controlled using an open-collector (or open-drain) discrete transistor and requires no external pull-up resistor. To disable the regulator output, the control pin must be pulled to less than 0.8Vdc with a low-level 0.5mA sink to ground.
3. The Standby input on the PT6920/6930 series may be driven by a differential output device, making it directly compatible with TTL logic. The control input has an internal pull-up to the input voltage V_{in} . A voltage of 1.8V or greater ensures that the regulator is enabled. *Do not* use devices that can drive the Standby control input above 5.5V or V_{in} .

Figure 1

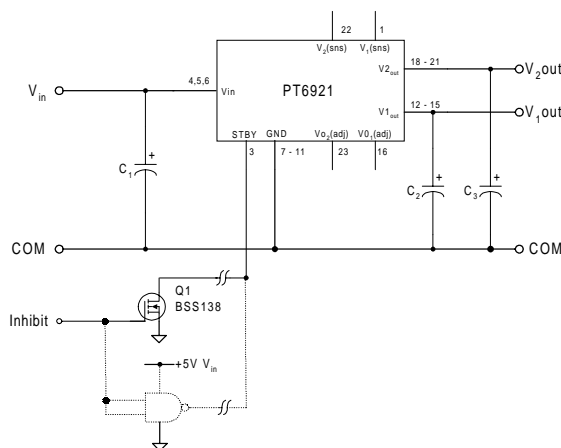

Turn-On Time: Turning Q_1 in Figure 1 off removes the low-voltage signal at pin 3 and enables both outputs from the PT6920/6930 regulator. Following a delay of about 5–10ms, $V_{1,out}$ and $V_{2,out}$ rise together until the lower voltage, $V_{2,out}$, reaches its set output. $V_{1,out}$ then continues to rise until both outputs reach full regulation voltage. The total power-up time is less than 15ms, and is relatively independent of load, temperature, and output capacitance. Figure 2 shows waveforms of the input current I_{in} , and output voltages $V_{1,out}$ and $V_{2,out}$, for a PT6921 (3.3V/2.5V). The turn-off of Q_1 corresponds to $t = 0$ secs. The waveforms were measured with a 5Vdc input voltage, and with resistive loads of 5.5A and 2.2A at the $V_{1,out}$ and $V_{2,out}$ outputs respectively.

Figure 2

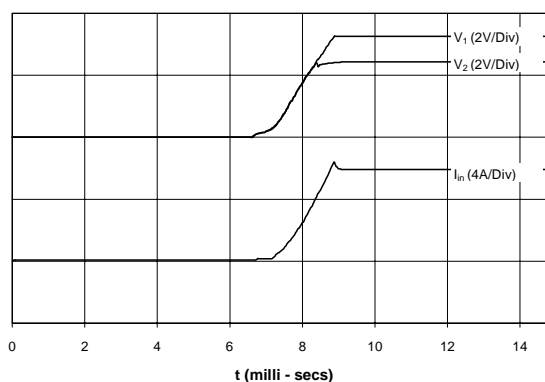

IMPORTANT NOTICE

Texas Instruments and its subsidiaries (TI) reserve the right to make changes to their products or to discontinue any product or service without notice, and advise customers to obtain the latest version of relevant information to verify, before placing orders, that information being relied on is current and complete. All products are sold subject to the terms and conditions of sale supplied at the time of order acknowledgment, including those pertaining to warranty, patent infringement, and limitation of liability.

TI warrants performance of its semiconductor products to the specifications applicable at the time of sale in accordance with TI's standard warranty. Testing and other quality control techniques are utilized to the extent TI deems necessary to support this warranty. Specific testing of all parameters of each device is not necessarily performed, except those mandated by government requirements.

Customers are responsible for their applications using TI components.

In order to minimize risks associated with the customer's applications, adequate design and operating safeguards must be provided by the customer to minimize inherent or procedural hazards.

TI assumes no liability for applications assistance or customer product design. TI does not warrant or represent that any license, either express or implied, is granted under any patent right, copyright, mask work right, or other intellectual property right of TI covering or relating to any combination, machine, or process in which such semiconductor products or services might be or are used. TI's publication of information regarding any third party's products or services does not constitute TI's approval, warranty or endorsement thereof.

PACKAGING INFORMATION

Orderable Device	Status ⁽¹⁾	Package Type	Package Drawing	Pins	Package Qty	Eco Plan ⁽²⁾	Lead/Ball Finish	MSL Peak Temp ⁽³⁾
PT6921A	NRND	SIP MOD ULE	EJJ	23	8	Pb-Free (RoHS)	Call TI	N / A for Pkg Type
PT6921C	NRND	SIP MOD ULE	EJK	23	8	Pb-Free (RoHS)	Call TI	Level-1-215C-UNLIM
PT6921N	NRND	SIP MOD ULE	EJH	23	10	Pb-Free (RoHS)	Call TI	N / A for Pkg Type
PT6922A	NRND	SIP MOD ULE	EJJ	23	8	Pb-Free (RoHS)	Call TI	N / A for Pkg Type
PT6922C	NRND	SIP MOD ULE	EJK	23	8	Pb-Free (RoHS)	Call TI	Level-1-215C-UNLIM
PT6922N	NRND	SIP MOD ULE	EJH	23	10	Pb-Free (RoHS)	Call TI	N / A for Pkg Type

⁽¹⁾ The marketing status values are defined as follows:

ACTIVE: Product device recommended for new designs.

LIFEBUY: TI has announced that the device will be discontinued, and a lifetime-buy period is in effect.

NRND: Not recommended for new designs. Device is in production to support existing customers, but TI does not recommend using this part in a new design.

PREVIEW: Device has been announced but is not in production. Samples may or may not be available.

OBSOLETE: TI has discontinued the production of the device.

⁽²⁾ Eco Plan - The planned eco-friendly classification: Pb-Free (RoHS), Pb-Free (RoHS Exempt), or Green (RoHS & no Sb/Br) - please check <http://www.ti.com/productcontent> for the latest availability information and additional product content details.

TBD: The Pb-Free/Green conversion plan has not been defined.

Pb-Free (RoHS): TI's terms "Lead-Free" or "Pb-Free" mean semiconductor products that are compatible with the current RoHS requirements for all 6 substances, including the requirement that lead not exceed 0.1% by weight in homogeneous materials. Where designed to be soldered at high temperatures, TI Pb-Free products are suitable for use in specified lead-free processes.

Pb-Free (RoHS Exempt): This component has a RoHS exemption for either 1) lead-based flip-chip solder bumps used between the die and package, or 2) lead-based die adhesive used between the die and leadframe. The component is otherwise considered Pb-Free (RoHS compatible) as defined above.

Green (RoHS & no Sb/Br): TI defines "Green" to mean Pb-Free (RoHS compatible), and free of Bromine (Br) and Antimony (Sb) based flame retardants (Br or Sb do not exceed 0.1% by weight in homogeneous material)

⁽³⁾ MSL, Peak Temp. -- The Moisture Sensitivity Level rating according to the JEDEC industry standard classifications, and peak solder temperature.

Important Information and Disclaimer:The information provided on this page represents TI's knowledge and belief as of the date that it is provided. TI bases its knowledge and belief on information provided by third parties, and makes no representation or warranty as to the accuracy of such information. Efforts are underway to better integrate information from third parties. TI has taken and continues to take reasonable steps to provide representative and accurate information but may not have conducted destructive testing or chemical analysis on incoming materials and chemicals. TI and TI suppliers consider certain information to be proprietary, and thus CAS numbers and other limited information may not be available for release.

In no event shall TI's liability arising out of such information exceed the total purchase price of the TI part(s) at issue in this document sold by TI to Customer on an annual basis.

IMPORTANT NOTICE

Texas Instruments Incorporated and its subsidiaries (TI) reserve the right to make corrections, modifications, enhancements, improvements, and other changes to its products and services at any time and to discontinue any product or service without notice. Customers should obtain the latest relevant information before placing orders and should verify that such information is current and complete. All products are sold subject to TI's terms and conditions of sale supplied at the time of order acknowledgment.

TI warrants performance of its hardware products to the specifications applicable at the time of sale in accordance with TI's standard warranty. Testing and other quality control techniques are used to the extent TI deems necessary to support this warranty. Except where mandated by government requirements, testing of all parameters of each product is not necessarily performed.

TI assumes no liability for applications assistance or customer product design. Customers are responsible for their products and applications using TI components. To minimize the risks associated with customer products and applications, customers should provide adequate design and operating safeguards.

TI does not warrant or represent that any license, either express or implied, is granted under any TI patent right, copyright, mask work right, or other TI intellectual property right relating to any combination, machine, or process in which TI products or services are used. Information published by TI regarding third-party products or services does not constitute a license from TI to use such products or services or a warranty or endorsement thereof. Use of such information may require a license from a third party under the patents or other intellectual property of the third party, or a license from TI under the patents or other intellectual property of TI.

Reproduction of TI information in TI data books or data sheets is permissible only if reproduction is without alteration and is accompanied by all associated warranties, conditions, limitations, and notices. Reproduction of this information with alteration is an unfair and deceptive business practice. TI is not responsible or liable for such altered documentation. Information of third parties may be subject to additional restrictions.

Resale of TI products or services with statements different from or beyond the parameters stated by TI for that product or service voids all express and any implied warranties for the associated TI product or service and is an unfair and deceptive business practice. TI is not responsible or liable for any such statements.

TI products are not authorized for use in safety-critical applications (such as life support) where a failure of the TI product would reasonably be expected to cause severe personal injury or death, unless officers of the parties have executed an agreement specifically governing such use. Buyers represent that they have all necessary expertise in the safety and regulatory ramifications of their applications, and acknowledge and agree that they are solely responsible for all legal, regulatory and safety-related requirements concerning their products and any use of TI products in such safety-critical applications, notwithstanding any applications-related information or support that may be provided by TI. Further, Buyers must fully indemnify TI and its representatives against any damages arising out of the use of TI products in such safety-critical applications.

TI products are neither designed nor intended for use in military/aerospace applications or environments unless the TI products are specifically designated by TI as military-grade or "enhanced plastic." Only products designated by TI as military-grade meet military specifications. Buyers acknowledge and agree that any such use of TI products which TI has not designated as military-grade is solely at the Buyer's risk, and that they are solely responsible for compliance with all legal and regulatory requirements in connection with such use.

TI products are neither designed nor intended for use in automotive applications or environments unless the specific TI products are designated by TI as compliant with ISO/TS 16949 requirements. Buyers acknowledge and agree that, if they use any non-designated products in automotive applications, TI will not be responsible for any failure to meet such requirements.

Following are URLs where you can obtain information on other Texas Instruments products and application solutions:

Products		Applications	
Amplifiers	amplifier.ti.com	Audio	www.ti.com/audio
Data Converters	dataconverter.ti.com	Automotive	www.ti.com/automotive
DSP	dsp.ti.com	Broadband	www.ti.com/broadband
Interface	interface.ti.com	Digital Control	www.ti.com/digitalcontrol
Logic	logic.ti.com	Military	www.ti.com/military
Power Mgmt	power.ti.com	Optical Networking	www.ti.com/opticalnetwork
Microcontrollers	microcontroller.ti.com	Security	www.ti.com/security
RFID	www.ti-rfid.com	Telephony	www.ti.com/telephony
Low Power Wireless	www.ti.com/lpw	Video & Imaging	www.ti.com/video
		Wireless	www.ti.com/wireless

Mailing Address: Texas Instruments, Post Office Box 655303, Dallas, Texas 75265
Copyright © 2007, Texas Instruments Incorporated

Looking for pricing, stock, or lifecycle information?

Click below to explore more details on WIN SOURCE:

 [View PT6921A on WIN SOURCE](#)

 [Texas Instruments](#) Information

Optimize Your Supply Chain with WIN SOURCE Solutions

-  Global Sourcing Solution
-  Obsolete Management
-  Cost Control Management
-  Shortage Management
-  Alternative Solution
-  Excess Inventory Management