



**THE DATASHEET OF
PTFM04BE222Q2N34BS**



Posistor® For Overheat Sensing

1. Part Numbering (Part Number)

<u>PT</u>	<u>FM</u>	<u>04</u>	<u>BH</u>	<u>471</u>	<u>Q</u>	<u>2N34</u>	<u>BS</u>
Product ID	Series	Dimensions	Temperature Characteristics	Resistance	Resistance Tolerance	Individual Specifications	Packaging

2. Ratings

Part Number	Temp. Char. (C.P.)	Resistance Value			Max. Voltage	Max. Current
		25°C	TS-10°C	※ TS		
PTFM04BH471Q2N34BS	BH	100ohm max.	330ohm max./50°C	470ohm min./60°C	16V DC.	0.1A
PTFM04BG471Q2N34BS	BG		330ohm max./60°C	470ohm min./70°C		
PTFM04BF471Q2N34BS	BF		330ohm max./70°C	470ohm min./80°C		
PTFM04BE471Q2N34BS	BE		330ohm max./80°C	470ohm min./90°C		
PTFM04BD471Q2N34BS	BD		330ohm max./90°C	470ohm min./100°C		
PTFM04BC471Q2N34BS	BC		330ohm max./100°C	470ohm min./110°C		
PTFM04BB471Q2N34BS	BB		330ohm max./110°C	470ohm min./120°C		
PTFM04BH222Q2N34BS	BH	330ohm max.	1.5kohm max./50°C	2.2kohm min./60°C	16V DC.	0.1A
PTFM04BG222Q2N34BS	BG		1.5kohm max./60°C	2.2kohm min./70°C		
PTFM04BF222Q2N34BS	BF		1.5kohm max./70°C	2.2kohm min./80°C		
PTFM04BE222Q2N34BS	BE		1.5kohm max./80°C	2.2kohm min./90°C		
PTFM04BD222Q2N34BS	BD		1.5kohm max./90°C	2.2kohm min./100°C		
PTFM04BC222Q2N34BS	BC		1.5kohm max./100°C	2.2kohm min./110°C		
PTFM04BB222Q2N34BS	BB		1.5kohm max./110°C	2.2kohm min./120°C		

※ TS = Sensing Temperature

• External dielectric withstand voltage between metallic terminal and lead wire. : 500 VDC / 5±1 sec.

3. Dimensions (mm)

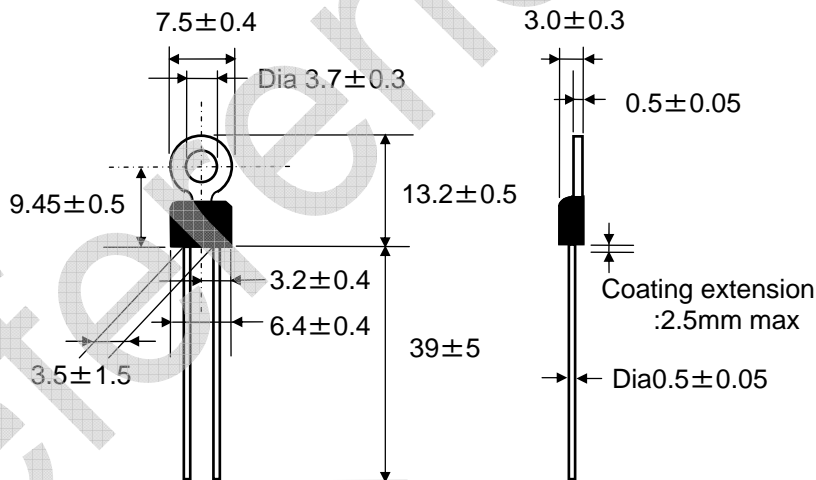

4. Quantity (Standard Quantity)

200pcs./unit bag.

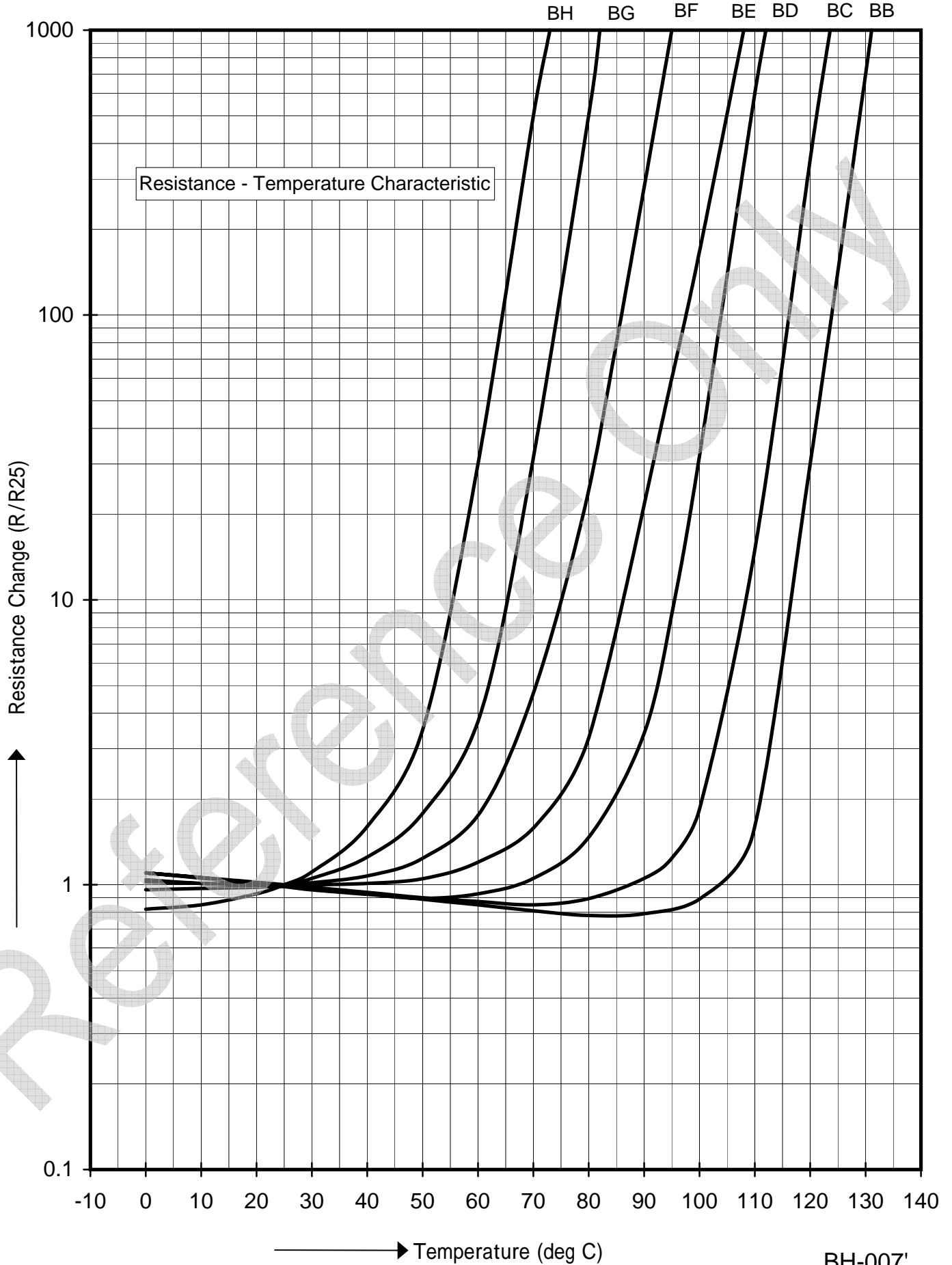

BH-007'

Notice for use

Caution

1. This product is designed for application which is used under ordinary environment.(room temperature, normal humidity, normal pressure) Do not expose this to the following environments, because all these factor can deteriorate the characteristic of this and can cause failure or burn out.
 - (1)Corrosive gas or deoxidizing gas (Cl₂, H₂S, NH₃, SO_x, NO_x etc.)
 - (2)Volatile, flammable gas
 - (3)Dusty place
 - (4)Place in a vacuum, reducing or putting pressure
 - (5)Place in splashed water, or high humidity and dewing place
 - (6)Salt water, oil, chemical liquid and solvent
 - (7)Vibratile place
 - (8)Other place equivalent to the above
2. Limitation of Applications
Please contact us before using our products for the under-mentioned applications requiring especially high reliability in order to prevent defects which might directly cause damage to other party's life body or property (listed below).
 - (1)Aircraft equipment
 - (2)Aerospace equipment
 - (3)Undersea equipment
 - (4)Power plant control equipment
 - (5)Medical equipment
 - (6)Transportation equipment (automobiles, trains, ships, etc.)
 - (7)Traffic signal equipment
 - (8)Disaster prevention / Crime prevention equipment
 - (9)Data-processing equipment
 - (10) Applications of similar complexity or with reliability requirements comparable to the applications listed in the above.
3. Be sure to provide an appropriate fail-safe function on your product to prevent a second damage that may be caused by the abnormal function or the failure of our product.

Notice

1. Do not apply abnormal voltage/current exceeding the specified maximum value. Because they may deteriorate or destroy PTC element.
2. Use this product within the specified temperature. A higher temperature may deteriorate the characteristic or material.
3. In case of mounting this product with screw , please do not apply an excessive tensile stress(9.8N) between resin case and lead.
4. Do not apply an excessive force(9.8N) to the lead. Otherwise, it may cause break off the junction between lead and element, may crack element or element may comes off resin case. Therefore, hold of element side lead wire is recommended when lead wire is bent or cut.
5. This product does not have waterproof construction. A splashed water may cause failure mode such as deterioration of characteristic or current leak.
So, Do NOT apply cleaning to immerse it into water or any solvent.
6. If you coat this product by resin, please evaluate the qualityl of this product before you use it. The stress of fource which is caused by coating materials or heat cycles may cause failure mode such as deterioration of characteristic or current leak in worst case.
7. This product is using the solder of 221+/-5 °C of melting points, in order to connect ceramics with a lead wire. Do not heat up a terminal area of this product over 180 °C.
8. The ceramic element of this product is fragile, and care must be taken not to load a excessive press-force or not to give a shock at handling. Such forces may cause cracking or chipping.

9. When the lead of this product is soldered, pay attention as follows to avoid the decline of element characteristic or break down the element.

- (1) Use Rosin type flux or non-activated flux(the content of chlorine shall be less than 0.2%)
- (2) Do not dip the body into flux. (Flux shall be coated to lead wire only for soldering.)
- (3) The pre-heat up should be conducted without melting the soldering of this product.

10. Do not apply tensile force or separating force to lead wire at soldering.

11. Do not touch the resin case by soldering iron. The soldering point shall be min. 5 mm away from the root of lead wire. Please solder the following conditions.

- Iron Tip Temperature : 360 degree C max.
- Soldering Time : 4 seconds max. / 1 terminal
- Number of Soldering : 1

12. To keep solderability of product from declining, following storage condition is recommended.

- (1) Storage condition : Temperature : -10 to +40°C
Humidity : less than 75%RH (not dewing condition)
- (2) Term: Please use this product within 6 months after shipment by first-in and first-out stocking system.
- (3) Handling after seal open: After unpacking of the minimum package, reseal it promptly or store it inside a sealed container with a drying agent.
- (4) Place: Do not store this product in corrosive gas(SO_x, Cl etc) or under sun-light.

13. This product is to be mounted to the part where heat should be detected as shown below.

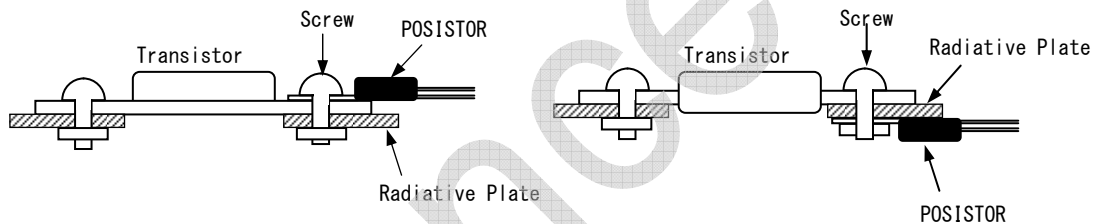

As it happen that detected heat will change after this product would be mounted, please make sure that your product has been evaluated confirmed after this product will be mounted.

14. The lag terminal plate is inserted into resin case. Incase of mounting this product with screw, please do not give strength to resin case.

15. Please do not use adhesive to mounting.

Looking for pricing, stock, or lifecycle information?

Click below to explore more details on WIN SOURCE:

- [View PTFM04BE222Q2N34BS on WIN SOURCE](#)
- [Murata Electronics North America Information](#)

Optimize Your Supply Chain with WIN SOURCE Solutions

- ✓ Global Sourcing Solution
- ✓ Obsolete Management
- ✓ Cost Control Management
- ✓ Shortage Management
- ✓ Alternative Solution
- ✓ Excess Inventory Management