



**THE DATASHEET OF
PX1004-1**



PX1004-1

**82.2 MHz
SAW Filter**

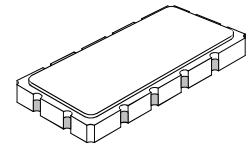

SM13365-12

- **Low Insertion Loss**
- **Excellent Selectivity**
- **Hermetic 13.3 X 6.5 mm Surface-mount Case**
- **Single-ended Input and Output**
- **Complies with Directive 2002/95/EC (RoHS)**
- **Moisture Sensitivity Level: 1**

Absolute Maximum Ratings

Rating	Value	Units
Maximum Incident Power in Passband	+10	dBm
Maximum DC Voltage Between any 2 Terminals	30	VDC
Storage Temperature Range	-40 to +85	°C
Suitable for Lead-free Soldering - Maximum Soldering Profile	260°C for 30 s	

Electrical Characteristics

Characteristic	Sym	Notes	Min	Typ	Max	Units
Nominal Center Frequency	f_C		82.20			MHz
Passband Insertion Loss at f_C 3 dB Passband Amplitude Ripple over $f_C \pm 15$ kHz Group Delay Variation over $f_C \pm 17$ kHz	IL			3.0	5.5	dB
	BW_3		± 25	± 42		kHz
					1.0	dB _{P-P}
		GDV			6.0	μ s _{P-P}
Third-Order Intermod. for -20 dBm tones at $f_C \pm 100$ & 200 kHz					-95	dBm
Rejection $f_C \pm 100$ kHz $f_C - 1500$ kHz to $f_C - 1600$ kHz Ultimate			11	16		dB
			65			
				65		
Operating Temperature Range	T_A		-20		+70	°C

Impedance Matching to 50 Ω unbalanced	External L-C
Case Style	SM13365-12 13.3 X 6.5 mm Nominal Footprint

 **CAUTION: Electrostatic Sensitive Device. Observe precautions for handling.**
NOTES:

1. The design, manufacturing process, and specifications of this device are subject to change.
2. US or International patents may apply.
3. RoHS compliant from the first date of manufacture.

Amplitude and Group Delay Plots

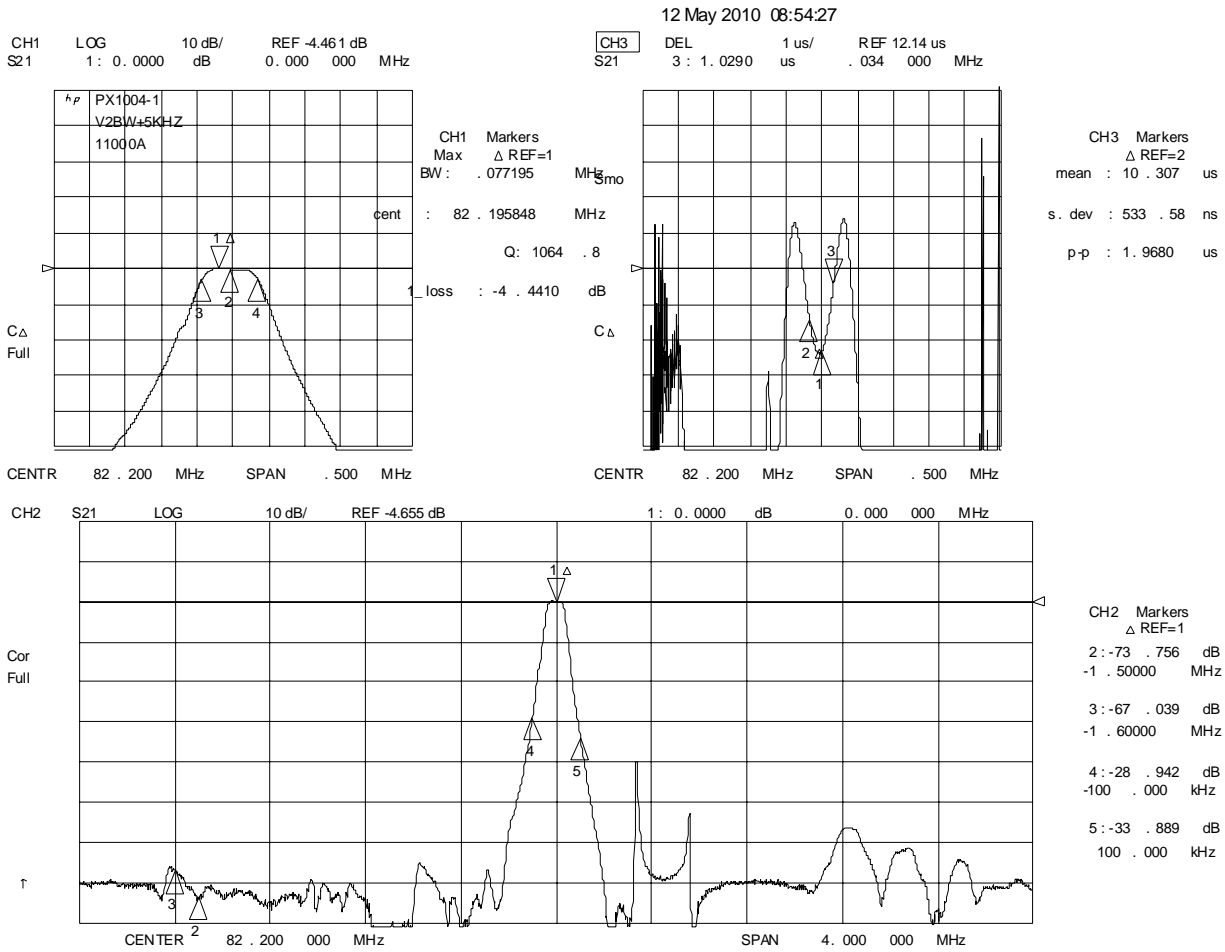

Input/Output Impedance and Passband Amplitude Plots

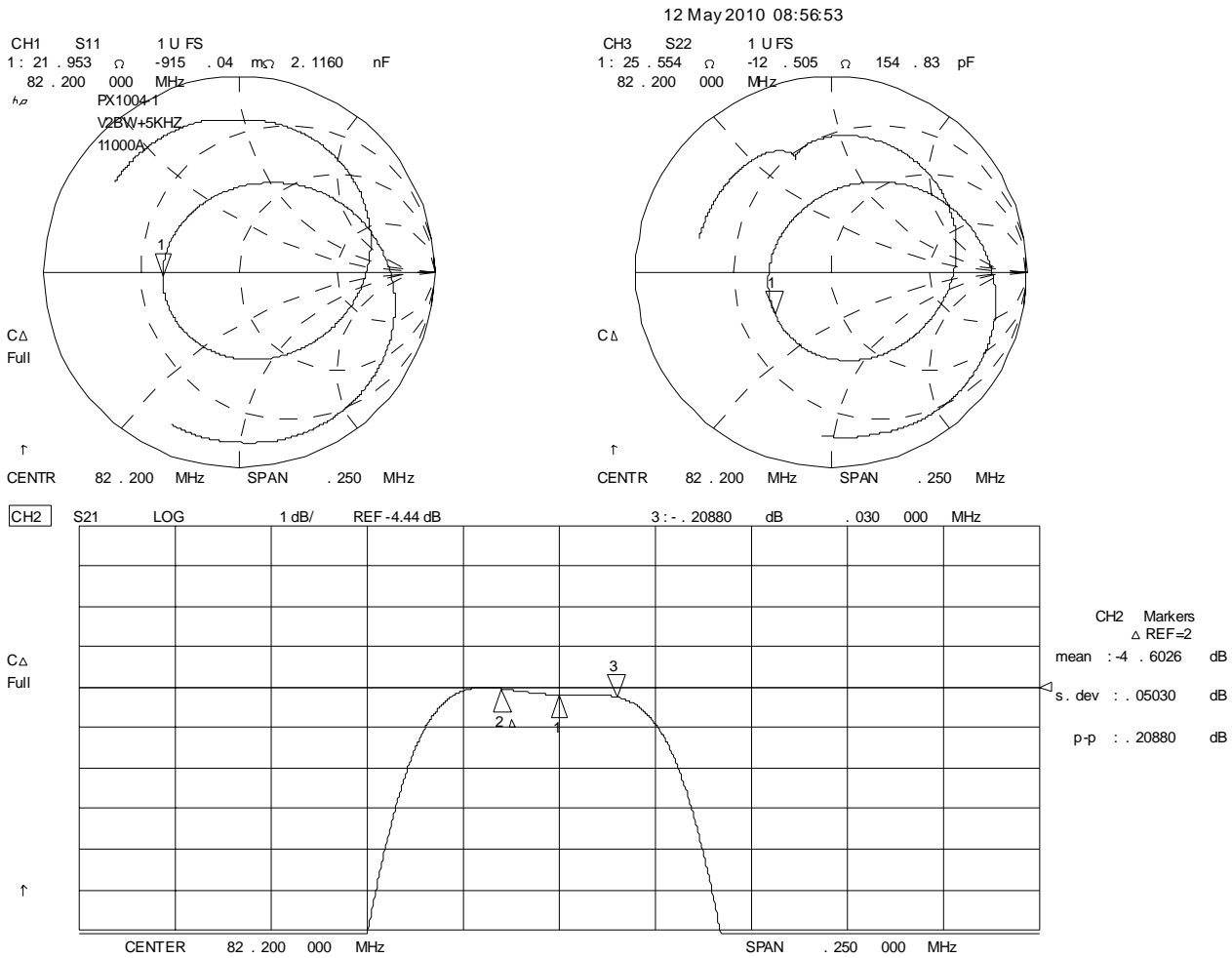

Filter Test Circuit

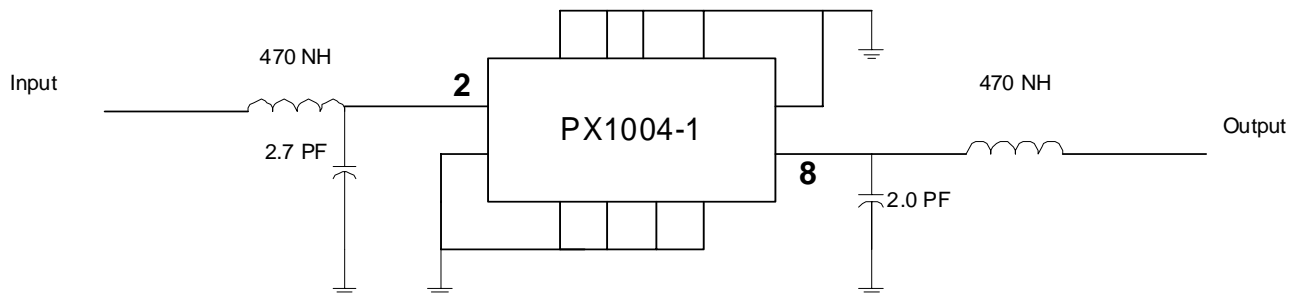

SM13365-12 Case

12-Terminal Ceramic Surface-Mount Case
13.3 x 6.5 mm Nominal Footprint

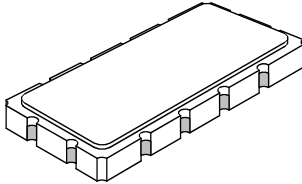

Case Dimensions						
Dimension	mm			Inches		
	Min	Nom	Max	Min	Nom	Max
A	13.08	13.31	13.60	0.515	0.524	0.535
B	6.27	6.50	6.80	0.247	0.256	0.268
C		1.91	2.00		0.075	0.079
D		1.50			0.059	
E		0.79			0.031	
H		1.0			0.039	
P		2.54			0.100	

Materials	
Solder Pad Termination	Au plating 30 - 60 ulnches (76.2-152 uM) over 80-200 ulnches (203-508 uM) Ni.
Lid	Fe-Ni-Co Alloy Electroless Nickel Plate (8-11% Phosphorus) 100-200 ulnches Thick
Body	Al ₂ O ₃ Ceramic

Symbolization:
 YY = Year
 WW = Week
 S = Shift
 ## = Sequence Code

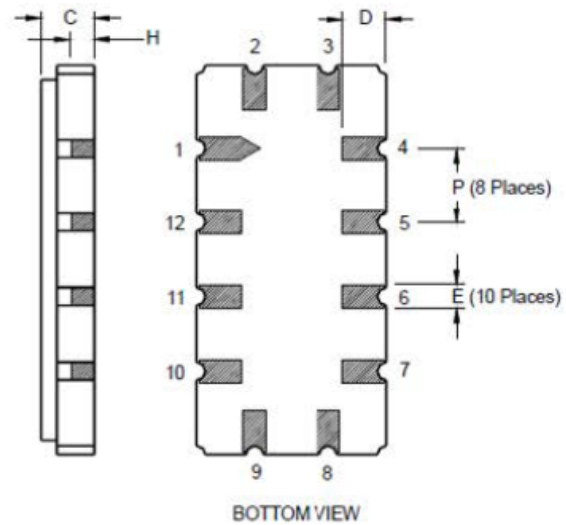
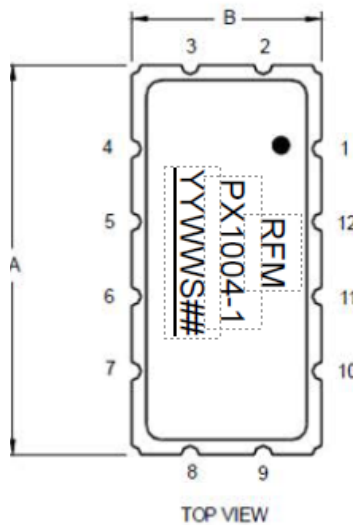
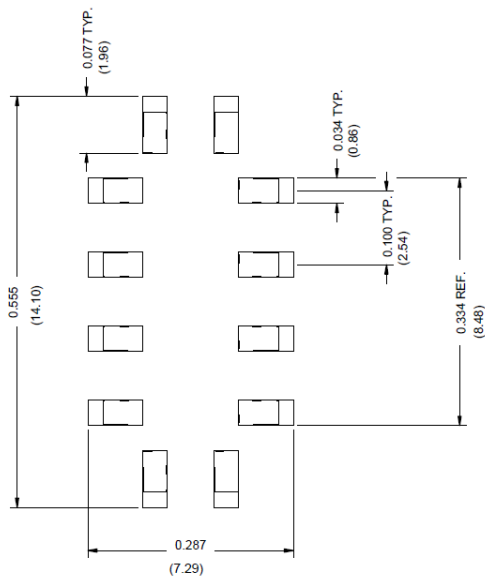

Tape and Reel Specifications

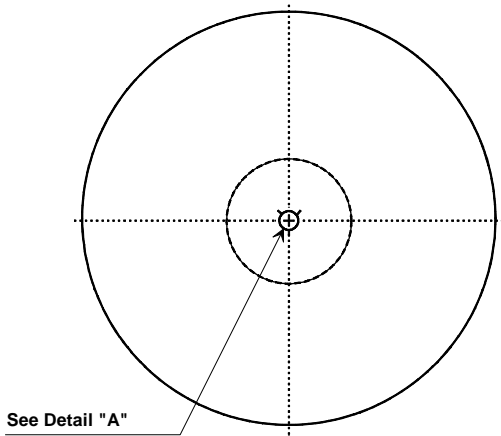

See Detail "A"

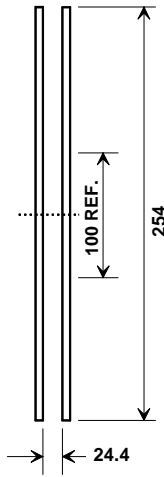

Tape and Reel Standard per ANSI/EIA-481

Quantity Per Reel
1000

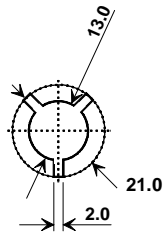

COMPONENT ORIENTATION and DIMENSIONS

Carrier Tape Dimensions	
Ao	7.0 mm
Bo	13.8 mm
Ko	2.0 mm
Pitch	12.0 mm
W	24.0 mm

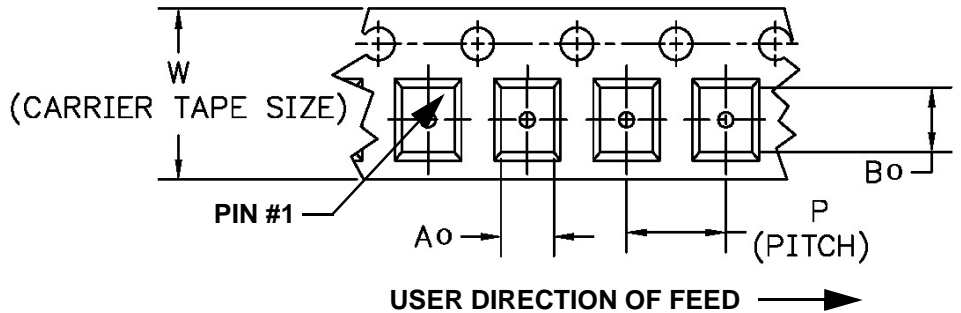
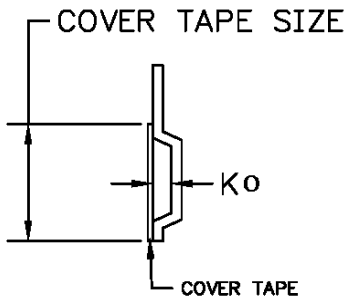

Recommended Reflow Profile

1. Preheating shall be fixed at 150~180°C for 60~90 seconds.
2. Ascending time to preheating temperature 150°C shall be 30 seconds min.
3. Heating shall be fixed at 220°C for 50~80 seconds and at 260°C +0/-5°C peak (10 seconds).
4. Time: 5 times maximum.

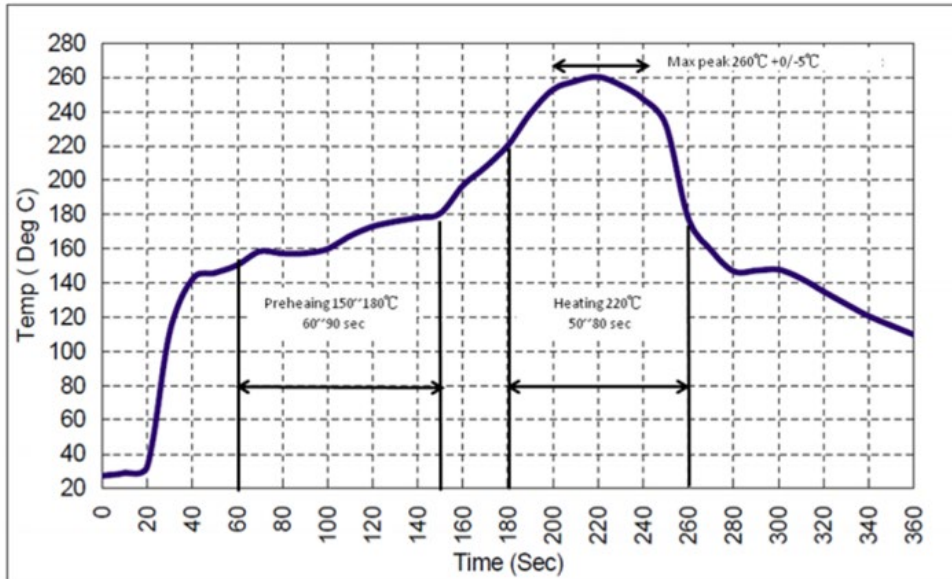

Looking for pricing, stock, or lifecycle information?

Click below to explore more details on WIN SOURCE:

 [View PX1004-1 on WIN SOURCE](#)

 [RF Monolithics, Inc Information](#)

Optimize Your Supply Chain with WIN SOURCE Solutions

-  Global Sourcing Solution
-  Obsolete Management
-  Cost Control Management
-  Shortage Management
-  Alternative Solution
-  Excess Inventory Management