



**THE DATASHEET OF
QS20.241**





POWER SUPPLY

- AC 100-240V Wide-range Input
- Width only 82mm
- Efficiency up to 93.9%
- ATEX and IECEx Approved (-A1 Version)
- -C1 Version with Conformal Coating PC-board
- 150% (720W) Peak Load Capability
- Safe Hiccup^{PLUS} Overload Mode
- Easy Fuse Tripping due to High Overload Current
- Active Power Factor Correction (PFC)
- Negligible low Inrush Current Surge
- Short-term Operation down to 60Vac and up to 300Vac
- Full Power Between -25°C and +60°C
- DC-OK Relay Contact
- Quick-connect Spring-clamp Terminals
- 3 Year Warranty

PRODUCT DESCRIPTION

The most outstanding features of this Dimension Q-Series DIN rail power supply are the high efficiency and the small size, which are achieved by a synchronous rectification and further novel design details.

With short-term peak power capability of 150% and built-in large sized output capacitors, these features help start motors, charge capacitors and absorb reverse energy and often allow a unit of a lower wattage class to be used.

High immunity to transients and power surges as well as low electromagnetic emission makes usage in nearly every environment possible.

The integrated output power manager, a wide range input voltage design and virtually no input inrush current make installation and usage simple. Diagnostics are easy due to the dry DC-OK contact, a green DC-OK LED and red overload LED.

Unique quick-connect spring-clamp terminals allow a safe and fast installation and a large international approval package for a variety of applications makes this unit suitable for nearly every situation.

SHORT-FORM DATA

Output voltage	DC 24V	
Adjustment range	24 - 28V	
Output current	20 – 17A	continuous
	30 – 26A	for typ. 4s
Output power	480W	continuous
	720W	for typ. 4s
Output ripple	< 100mVpp	20Hz to 20MHz
Input voltage	AC 100-240V	±15%
Mains frequency	50-60Hz	±6%
AC Input current	4.56 / 2.48A	at 120 / 230Vac
Power factor	0.95 / 0.90	at 120 / 230Vac
AC Inrush current	typ. 9 / 7A peak	at 120 / 230Vac
Efficiency	92.4 / 93.9%	at 120 / 230Vac
Losses	39.6 / 31.4W	at 120 / 230Vac
Temperature range	-25°C to +70°C	operational
Derating	12W/°C	+60 to +70°C
Hold-up time	typ. 32 / 51ms	at 120 / 230Vac
Dimensions	82x124x127mm	WxHxD

ORDER NUMBERS

Power Supply	QS20.241	24-28V Standard unit
	QS20.241-A1	ATEX approved unit
	QS20.241-C1	Conformal coating unit
Accessory	ZM2.WALL	Wall mount bracket
	ZM15.SIDE	Side mount bracket
	YR40.242	Redundancy module
	YR40.245	Redundancy module

MAIN APPROVALS

For details and the complete approval list, see chapter 19.



UL 508



UL 60950-1



ATEX



IECEX



Marine





Marine

INDEX

	Page		Page
1. Intended Use.....	3	22. Accessories.....	22
2. Installation Instructions.....	3	22.1. ZM2.WALL-Wall Mounting Bracket.....	22
3. AC-Input.....	5	22.2. ZM15.SIDE-Side Mounting Bracket.....	22
4. DC-Input.....	6	22.3. -YR40.242 - Redundancy Modules.....	23
5. Input Inrush Current.....	6	22.4. YR40.245 - Redundancy Modules.....	23
6. Output.....	7	23. Application Notes.....	24
7. Hold-up Time.....	9	23.1. Repetitive Pulse Loading.....	24
8. DC-OK Relay Contact.....	9	23.2. Peak Current Capability.....	25
9. Efficiency and Power Losses.....	10	23.3. Back-feeding Loads.....	25
10. Lifetime Expectancy and MTBF.....	11	23.4. External Input Protection.....	25
11. Functional Diagram.....	11	23.5. Charging of Batteries.....	26
12. Terminals and Wiring.....	12	23.6. Output Circuit Breakers.....	26
13. Front Side and User Elements.....	13	23.7. Parallel Use to Increase Output Power.....	27
14. EMC.....	14	23.8. Parallel Use for Redundancy.....	27
15. Environment.....	15	23.9. Series Operation.....	28
16. Protection Features.....	16	23.10. Inductive and Capacitive Loads.....	28
17. Safety Features.....	16	23.11. Operation on Two Phases.....	28
18. Dielectric Strength.....	17	23.12. Use in a Tightly Sealed Enclosure.....	28
19. Approved, Fulfilled or Tested Standards.....	18	23.13. Mounting Orientations.....	29
20. Regulatory Product Compliance.....	20		
21. Physical Dimensions and Weight.....	21		

The information presented in this document is believed to be accurate and reliable and may change without notice.
 No part of this document may be reproduced or utilized in any form without permission in writing from the publisher.

TERMINOLOGY AND ABBREVIATIONS

PE and  symbol	PE is the abbreviation for Protective Earth and has the same meaning as the symbol  .
Earth, Ground	This document uses the term “earth” which is the same as the U.S. term “ground”.
t.b.d.	To be defined, value or description will follow later.
AC 230V	A figure displayed with the AC or DC before the value represents a nominal voltage with standard tolerances (usually ±15%) included. E.g.: DC 12V describes a 12V battery disregarding whether it is full (13.7V) or flat (10V)
230Vac	A figure with the unit (Vac) at the end is a momentary figure without any additional tolerances included.
50Hz vs. 60Hz	As long as not otherwise stated, AC 230V parameters are valid at 50Hz mains frequency.
may	A key word indicate flexibility of choice with no implied preference.
shall	A key word indicate a mandatory requirement.
should	A key word indicate flexibility of choice with a strongly preferred implementation.

1. INTENDED USE

This device is designed for installation in an enclosure and is intended for commercial use, such as in industrial control, process control, monitoring and measurement equipment or the like.

Do not use this device in equipment, where malfunctioning may cause severe personal injury or threaten human life without additional appropriate safety devices, that are suited for the end-application.

If this device is used in a manner outside of its specification, the protection provided by the device may be impaired.

2. INSTALLATION INSTRUCTIONS

⚠ WARNING Risk of electrical shock, fire, personal injury or death.

- Turn power off before working on the device and protect against inadvertent re-powering.
- Do not open, modify or repair the device.
- Use caution to prevent any foreign objects from entering into the housing.
- Do not use in wet locations or in areas where moisture or condensation can be expected.
- Do not touch during power-on, and immediately after power-off. Hot surface may cause burns.

Obey the following installation instructions:

This device may only be installed and put into operation by qualified personnel.

This device does not contain serviceable parts. The tripping of an internal fuse is caused by an internal defect.

If damage or malfunction should occur during installation or operation, immediately turn power off and send unit to the factory for inspection.

Install device in an enclosure providing protection against electrical, mechanical and fire hazards.

Install the device onto a DIN rail according to EN 60715 with the input terminals on the bottom of the device. Other mounting orientations require a reduction in output current.

Make sure that the wiring is correct by following all local and national codes. Use appropriate copper cables that are designed for a minimum operating temperature of 60°C for ambient temperatures up to +45°C, 75°C for ambient temperatures up to +60°C and 90°C for ambient temperatures up to +70°C.

Ensure that all strands of a stranded wire enter the terminal connection. Use ferrules for wires on the input terminals.

The device is designed for pollution degree 2 areas in controlled environments. No condensation or frost is allowed.

The enclosure of the device provides a degree of protection of IP20. The housing does not provide protection against spilled liquids.

The device is designed for overvoltage category II zones. Below 2000m altitude the device is tested for impulse withstand voltages up to 4kV, which corresponds to OVC III according to IEC 60664-1.

The device is designed as "Class of Protection I" equipment according to IEC 61140. Do not use without a proper PE (Protective Earth) connection.

The device is suitable to be supplied from TN, TT or IT mains networks. The continuous voltage between the input terminal and the PE potential must not exceed 276Vac.

The input can also be powered from batteries or similar DC sources. The continuous voltage between the supply voltage and the PE/ground potential must not exceed 375Vdc.

A disconnecting means shall be provided for the input of the device.

The device is designed for convection cooling and does not require an external fan. Do not obstruct airflow and do not cover ventilation grid!

The device is designed for altitudes up to 5000m. Above 2000m a reduction in output current is required.

Keep the following minimum installation clearances: 40mm on top, 20mm on the bottom, 5mm left and right side. Increase the 5mm to 15mm in case the adjacent device is a heat source. When the device is permanently loaded with less than 50%, the 5mm can be reduced to zero.

The device is designed, tested and approved for branch circuits up to 20A without additional protection device. If an external fuse is utilized, do not use circuit breakers smaller than 10A B- or C-Characteristic to avoid a nuisance tripping of the circuit breaker.

The maximum surrounding air temperature is +70°C. The operational temperature is the same as the ambient or surrounding air temperature and is defined 2cm below the device.

The device is designed to operate in areas between 5% and 95% relative humidity.

Only QS20.241 and QS20.241-C1

Installation Instructions for Hazardous Location Areas

The device is suitable for use in Class I Division 2 Groups A, B, C, D locations.

Substitution of components may impair suitability for this environment.

Do not disconnect the device or operate the voltage adjustment unless power has been switched off or the area is known to be non-hazardous.

Only QS20.241-A1

Installation Instructions for Hazardous Location Areas

The device is suitable for use in Class I Division 2 Groups A, B, C, D locations and for use in Group II Category 3 (Zone 2) environments.

Classification: ATEX: EPS 09 ATEX 1 236 X, II 3G Ex ec nC IIC T3 Gc / IECEx EPS 12.0031X

Do not use in mounting orientations other than the input terminals on bottom of the unit. Do not use with DC input voltages or above +60°C ambient.

WARNING EXPLOSION HAZARDS!

Substitution of components may impair suitability for this environment.

Do not disconnect the device or operate the voltage adjustment unless power has been switched off or the area is known to be non-hazardous.

A suitable enclosure must be provided for the end product which has a minimum protection of IP54 and fulfils the requirements of the EN 60079-0.

3. AC-INPUT

AC input	nom.	AC 100-240V	suitable for TN-, TT- and IT mains networks
AC input range		85-276Vac	
		60-85Vac	full power for 200ms, no damage between 0 and 85Vac
		276-300Vac	< 500ms
Allowed voltage L or N to earth	max.	276Vac	continuous, IEC 62103
Input frequency	nom.	50–60Hz	±6%
Turn-on voltage	typ.	77Vac	steady-state value, see Fig. 3-1
Shut-down voltage	typ.	73Vac	steady-state value, see Fig. 3-1
	typ.	53Vac	dynamic value

		AC 100V	AC 120V	AC 230V	
Input current	typ.	5.47A	4.56A	2.48A	at 24V, 20A, see Fig. 3-3
Power factor *)	typ.	0.96	0.95	0.90	at 24V, 20A, see Fig. 3-4
Crest factor **)	typ.	1.6	1.7	2.05	at 24V, 20A
Start-up delay	typ.	640ms	610ms	660ms	see Fig. 3-2
Rise time	typ.	80ms	80ms	80ms	0mF, 24V, 20A, see Fig. 3-2
	typ.	85ms	85ms	85ms	20mF, 24V, 20A, see Fig. 3-2
Turn-on overshoot	max.	100mV	100mV	100mV	see Fig. 3-2

*) The power factor is the ratio of the true (or real) power to the apparent power in an AC circuit.

***) The crest factor is the mathematical ratio of the peak value to RMS value of the input current waveform.

Fig. 3-1 Input voltage range

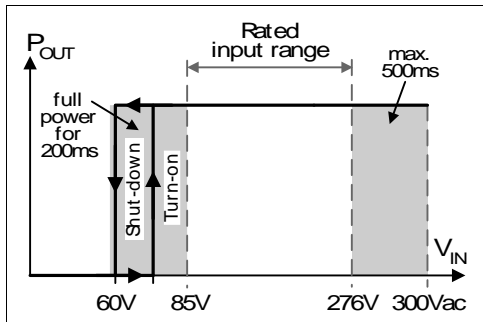

Fig. 3-2 Turn-on behaviour, definitions

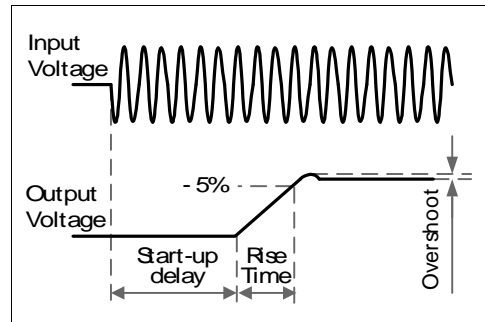

Fig. 3-3 Input current vs. output load at 24V

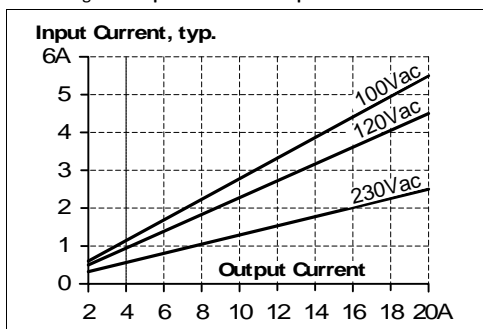
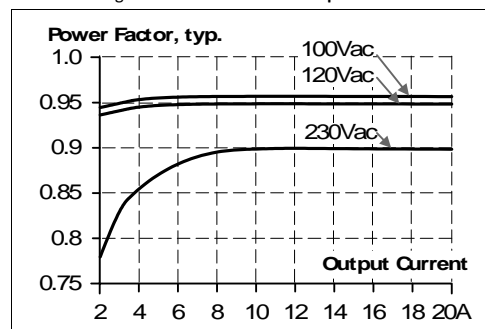

Fig. 3-4 Power factor vs. output load



4. DC-INPUT

DC input	nom.	DC 110-150V	-20%/+25%
DC input range		88-187Vdc	
DC input current	typ.	4.6A	110Vdc, at 24V, 20A
Allowed Voltage L/N to Earth	max.	375Vdc	IEC 62103
Turn-on voltage	typ.	74Vdc	steady state value
Shut-down voltage	typ.	69Vdc	steady state value

Fig. 4-1 Wiring for DC Input

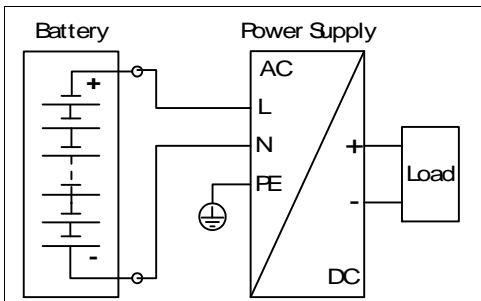

Instructions for DC use:

- Use a battery or similar DC source. For other sources contact PULS
- Connect +pole to L and -pole to N.
- Connect the PE terminal to an earth wire or to the machine ground.

5. INPUT INRUSH CURRENT

An active inrush limitation circuit limits the input inrush current after turn-on of the input voltage and after short input voltage interruptions.

The charging current into EMI suppression capacitors is disregarded in the first microseconds after switch-on.

		AC 100V	AC 120V	AC 230V	
Inrush current	max.	13A _{peak}	13A _{peak}	13A _{peak}	over entire temperature range; mains interruptions > 750ms
	typ.	11A _{peak}	9A _{peak}	7A _{peak}	over entire temperature range; mains interruptions > 750ms
Inrush energy	max.	5A ² s	5A ² s	5A ² s	over entire temperature range; mains interruptions > 750ms
Inrush delay (A)	typ.	400ms	400ms	650ms	see (A) in Fig. 5-1

Fig. 5-1 Input inrush current, typical behaviour

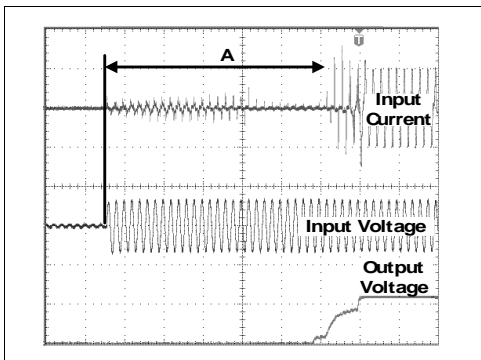

A.... Inrush delay

Input: 230Vac
 Output: 24V, 20A
 Ambient: 25°C
 Upper curve: Input current 5A / DIV
 Middle curve: Input voltage 500V / DIV
 Lower curve: Output voltage 20V / DIV
 Time basis: 100ms / DIV

6. OUTPUT

Output voltage	nom.	24V	
Adjustment range		24-28V	guaranteed
	max.	30V ****)	at clockwise end position of potentiometer
Factory setting	typ.	24.1V	±0.2%, at full load, cold unit
Line regulation	max.	10mV	60-300Vac
Load regulation	max.	100mV	static value, 0A → 20A
Ripple and noise voltage	max.	100mVpp	20Hz to 20MHz, 50Ohm
Output current	nom.	20A	continuously available at 24V, see Fig. 6-1
	nom.	17A	continuously available at 28V, see Fig. 6-1
	nom.	30A *)	short term available BonusPower *), at 24V, for typical 4s, see Fig. 6-1
	nom.	26A *)	short term available BonusPower *), at 28V, for typical 4s, see Fig. 6-1
Output power	nom.	480W	continuously available
	nom.	720W *)	short term available BonusPower *)
BonusPower time	typ.	4s	duration until the output voltage dips, see Fig. 6-2
	min.	3.5s	
	max.	4.5s	
BonusPower recovery time	typ.	7s	overload free time to reset power manager Fig. 6-4
Overload behaviour		cont. current	output voltage > 20Vdc, see Fig. 6-1
		Hiccup ^{PLUS} mode**)	output voltage < 20Vdc, see Fig. 6-1
Short-circuit current	min.	30A ***)	load impedance 50mOhm, see Fig. 6-3
	max.	40A ***)	load impedance 50mOhm, see Fig. 6-3
	max.	14A ***)	average (R.M.S.) current, load impedance <10mOhm, see Fig. 6-3
Output capacitance	typ.	8 500µF	included inside the power supply

*) **BonusPower, short term power capability (up to typ. 4s)**
 The power supply is designed to support loads with a higher short-term power requirement without damage or shutdown. The short-term duration is hardware controlled by an output power manager. This BonusPower is repeatedly available. Detailed information can be found in chapter 23.1. If the power supply is loaded longer with the BonusPower than shown in the Bonus-time diagram (see Fig. 6-2), the max. output power is automatically reduced to 480W. If the power requirement is continuously above 480W and the voltage falls below approx. 20V (due to the current regulating mode at overload), the unit shuts-off and makes periodical restart attempts. This behaviour is called hiccup mode, which is described below. If the voltage is above 20V, the unit continuously delivers current.

***) **Hiccup^{PLUS} Mode**
 At heavy overloads (when output voltage falls below 20V), the power supply delivers continuous output current for 2s. After this, the output is switched off for approx. 17s before a new start attempt is automatically performed. This cycle is repeated as long as the overload exists. If the overload has been cleared, the device will operate normally. See also Fig. 6-3.
 During the off-period a small rest voltage and rest current is present on the output.

***) Discharge current of output capacitors is not included.

****) This is the maximum output voltage which can occur at the clockwise end position of the potentiometer due to tolerances. It is not guaranteed value which can be achieved. The typical value is about 28.5V.

Peak current capability (up to several milliseconds)

The power supply can deliver a peak current which is higher than the specified short term current. This helps to start current demanding loads or to safely operate subsequent circuit breakers.

The extra current is supplied by the output capacitors inside the power supply. During this event, the capacitors will be discharged and causes a voltage dip on the output. Detailed curves can be found in chapter 23.2.

Peak current voltage dips	typ.	from 24V to 20V	at 40A for 50ms, resistive load
	typ.	from 24V to 17V	at 100A for 2ms, resistive load
	typ.	from 24V to 16V	at 100A for 5ms, resistive load

Fig. 6-1 Output voltage vs. output current, typ.

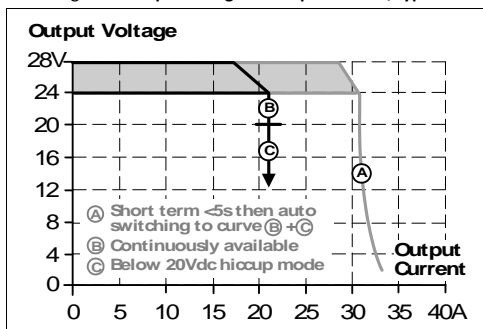

Fig. 6-2 Bonus time vs. output power

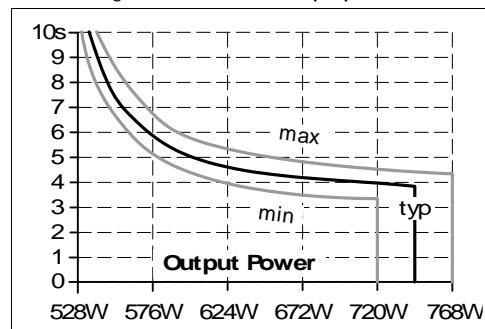

Fig. 6-3 Short-circuit on output, hiccup mode (typ.)

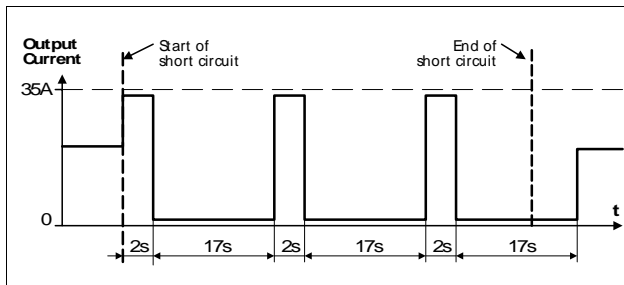
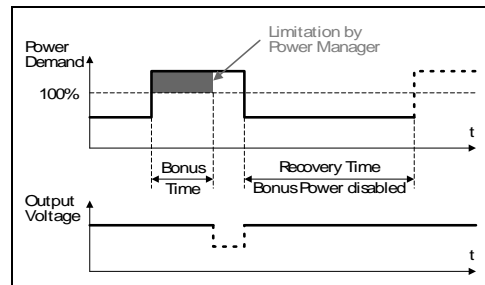

Fig. 6-4 BonusPower recovery time



The BonusPower is available as soon as power comes on and immediately after the end of an output short circuit or output overload.

Fig. 6-5 BonusPower after input turn-on

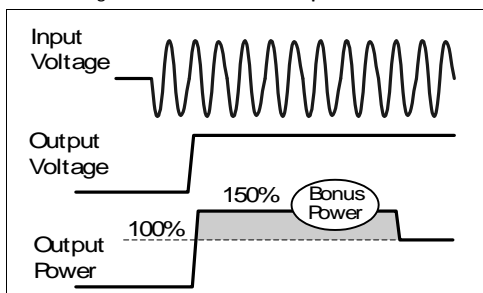
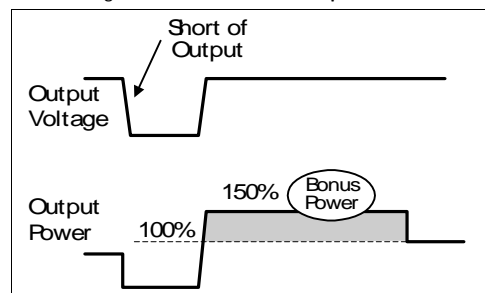

Fig. 6-6 BonusPower after output short



7. HOLD-UP TIME

		AC 100V	AC 120V	AC 230V	
Hold-up Time	typ.	64ms	64ms	99ms	at 24V, 10A, see Fig. 7-1
	typ.	32ms	32ms	51ms	at 24V, 20A, see Fig. 7-1

Fig. 7-1 Hold-up time vs. input voltage

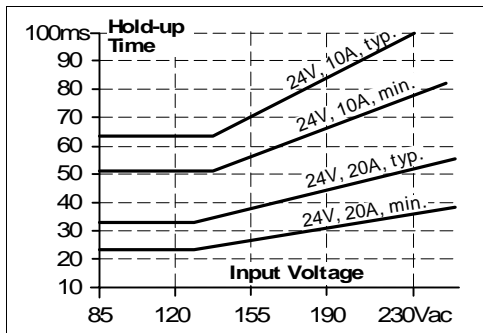
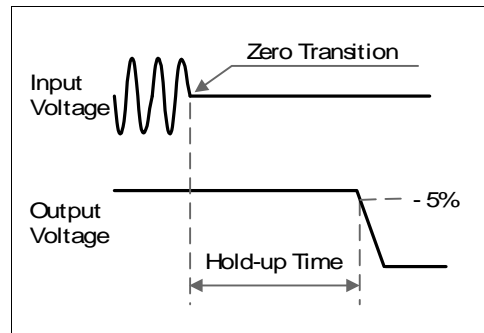

Fig. 7-2 Shut-down behaviour, definitions



8. DC-OK RELAY CONTACT

This feature monitors the output voltage, which is produced by the power supply itself. It is independent of a back-fed voltage from a unit connected in parallel to the power supply output.

Contact closes	As soon as the output voltage reaches the adjusted output voltage level.		
Contact opens	As soon as the output voltage dips more than 10% below the adjusted output voltage. Short dips will be extended to a signal length of 250ms. Dips shorter than 1ms will be ignored.		
Contact re-closes	As soon as the output voltage exceeds 90% of the adjusted voltage.		
Contact ratings	max.	60Vdc 0.3A, 30Vdc 1A, 30Vac 0.5A	resistive load
	min.	1mA at 5Vdc	min. permissible load
Isolation voltage	See dielectric strength table in chapter 18.		

Fig. 8-1 DC-OK relay contact behavior

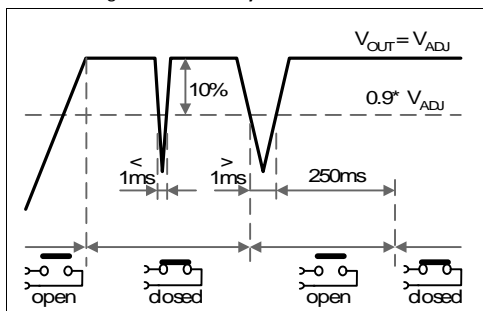

Note: The DC-OK feature requires that the output voltage reaches the nominal (=adjusted) level after turn-on in order to function according to specification. If this level cannot be achieved, the overload LED will be on and the DC-OK contact will be open. The overload signal will only shut off as soon as the adjusted voltage is reached. This is an important condition to consider particularly, if the load is a battery, the power supply is used in parallel or the power supply is used for N+1 redundant system.

9. EFFICIENCY AND POWER LOSSES

		AC 100V	AC 120V	AC 230V	
Efficiency	typ.	91.6%	92.4%	93.9%	at 24V, 20A
Average efficiency *)	typ.	91.0%	91.8%	92.9%	25% at 5A, 25% at 10A, 25% at 15A. 25% at 20A
Power losses	typ.	9.0W	9.2W	10.0W	at 24V, 0A
	typ.	44.0W	39.6W	31.4W	at 24V, 20A

*) The average efficiency is an assumption for a typical application where the power supply is loaded with 25% of the nominal load for 25% of the time, 50% of the nominal load for another 25% of the time, 75% of the nominal load for another 25% of the time and with 100% of the nominal load for the rest of the time.

Fig. 9-1 Efficiency vs. output current at 24V, typ

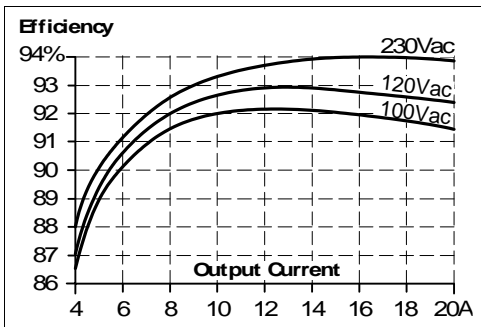

Fig. 9-2 Losses vs. output current at 24V, typ.

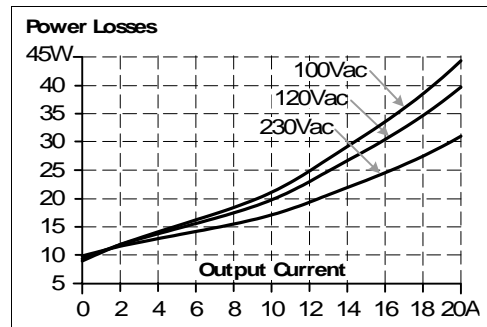

Fig. 9-3 Efficiency vs. input voltage at 24V, 20A, typ.

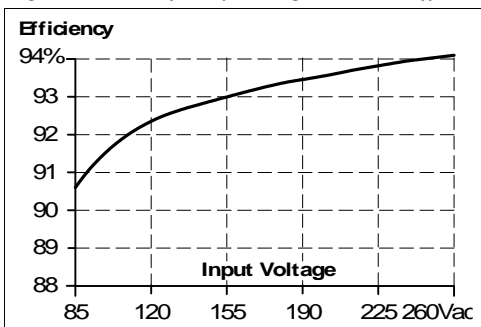
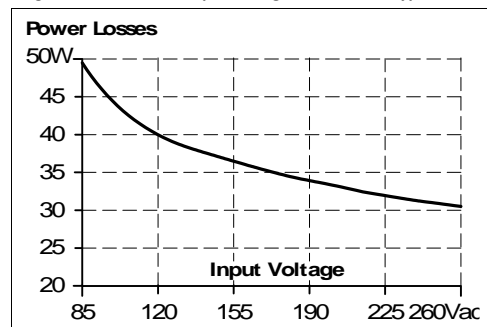

Fig. 9-4 Losses vs. input voltage at 24V, 20A, typ.



10. LIFETIME EXPECTANCY AND MTBF

	AC 100V	AC 120V	AC 230V	
Lifetime expectancy *)	54 000h	59 000h	71 000h	at 24V, 20A and 40°C
	135 000h	143 000h	164 000h	at 24V, 10A and 40°C
	153 000h *)	165 000h *)	200 000h *)	at 24V, 20A and 25°C
MTBF **) SN 29500, IEC 61709	407 000h	441 000h	469 000h	at 24V, 20A and 40°C
	749 000h	799 000h	840 000h	at 24V, 20A and 25°C
MTBF **) MIL HDBK 217F	204 000h	215 000h	229 000h	at 24V, 20A and 40°C; Ground Benign GB40
	273 000h	288 000h	308 000h	at 24V, 20A and 25°C; Ground Benign GB25

*) The **Lifetime expectancy** shown in the table indicates the minimum operating hours (service life) and is determined by the lifetime expectancy of the built-in electrolytic capacitors. Lifetime expectancy is specified in operational hours and is calculated according to the capacitor's manufacturer specification. The manufacturer of the electrolytic capacitors only guarantees a maximum life of up to 15 years (131 400h). Any number exceeding this value is a calculated theoretical lifetime which can be used to compare devices.

) **MTBF stands for **Mean Time Between Failure**, which is calculated according to statistical device failures, and indicates reliability of a device. It is the statistical representation of the likelihood of a unit to fail and does not necessarily represent the life of a product.

The MTBF figure is a statistical representation of the likelihood of a device to fail. A MTBF figure of e.g. 1 000 000h means that statistically one unit will fail every 100 hours if 10 000 units are installed in the field. However, it can not be determined if the failed unit has been running for 50 000h or only for 100h.

11. FUNCTIONAL DIAGRAM

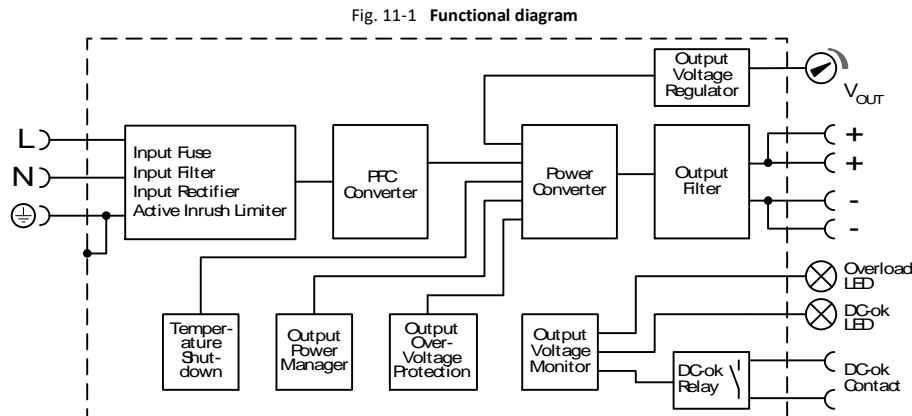

12. TERMINALS AND WIRING

Bi-stable, quick-connect spring clamp terminals. Shipped in open position.

- IP20 Finger safe construction.
- Suitable for field- and factory installation.

	Input	Output	DC-OK signal
Type	spring-clamp terminal	spring-clamp terminal	spring-clamp terminal
Solid wire	0.5-6mm ²	0.5-6mm ²	0.3-4mm ²
Stranded wire	0.5-4mm ²	0.5-4mm ²	0.3-2.5mm ²
American Wire Gauge	20-10 AWG	20-10 AWG	26-12 AWG
Wire stripping length	10mm	10mm	6mm
Max. wire diameter (including ferrules)	2.8mm	2.8mm	2.25mm

Instructions:

- Use appropriate copper cables that are designed for minimum operating temperatures of:
 - 60°C for ambient up to 45°C and
 - 75°C for ambient up to 60°C minimum
 - 90°C for ambient up to 70°C minimum.
- Follow national installation codes and installation regulations!
- Ensure that all strands of a stranded wire enter the terminal connection!
- Do not use the unit without PE connection.
- Unused terminal compartments should be securely tightened.
- Ferrules are allowed.

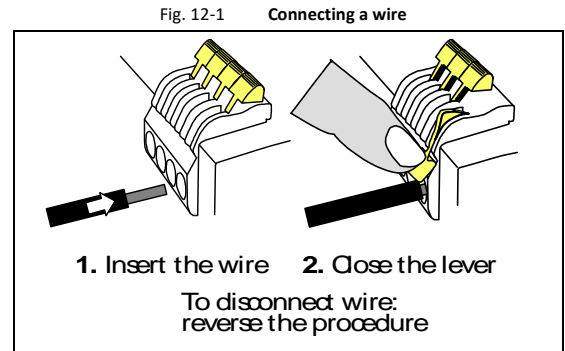

Daisy Chaining of Outputs:

Daisy chaining (jumping from one power supply output to the next) is allowed as long as the average output current through one terminal pin does not exceed 25A. If the current is higher, use a separate distribution terminal block as shown in Fig. 12-3.

Fig. 12-2 Daisy chaining of outputs

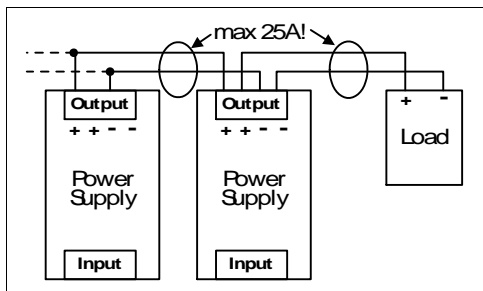
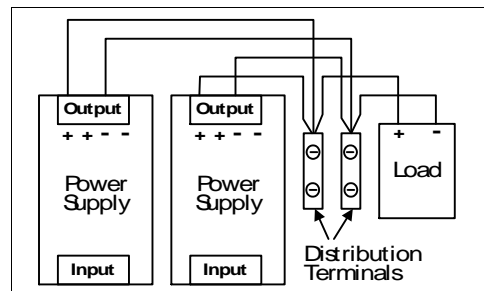

Fig. 12-3 Using distribution terminals



13. FRONT SIDE AND USER ELEMENTS

Fig. 13-1 Front side



- A Input Terminals** (Quick-connect spring-clamp terminals)
 - N, L Line input
 - ⊕ PE (Protective Earth) input
- B Output Terminals** (Quick-connect spring-clamp terminals, two pins per pole)
 - + Positive output
 - Negative (return) output
- C DC-OK Relay Contact** (Quick-connect spring-clamp terminals)

The DC-OK relay contact is synchronized with the DC-OK LED. See chapter 8 for details.
- D Output voltage potentiometer**

Open the flap to adjust the output voltage. Factory set: 24.1V
- E DC-OK LED** (green)

On, when the output voltage is >90% of the adjusted output voltage
- F Overload LED** (red)

On, when the voltage on the output terminals is <90% of the adjusted output voltage, or in case of a short circuit in the output. Input voltage is required.

Indicators, LEDs

	Overload LED	DC-OK LED	DC-OK Contact
Normal mode	OFF	ON	Closed
During BonusPower	OFF	ON	Closed
Overload ($V_{OUT} < 90\%$)	*)	OFF	Open
Output short circuit	*)	OFF	Open
Temperature Shut-down	*)	OFF	Open
No input power	OFF	OFF	Open

*) Up to 4s of overloading, the power supply delivers continuous output current. After this, the output power is reduced to nearly zero for approx. 17s before a new start attempt is automatically performed. If the overload has been cleared, the device will operate normally. If the overload still exists, the output current will be delivered for 2 to 4s (depending on the overload) again followed by a 17s rest time. This cycle is repeated as long as the overload exists. The red overload LED is permanently on when the overload current is continuously flowing. During the 17s rest period, the red LED is flashing with a frequency of approx. 1.3Hz.

14. EMC

The power supply is suitable for applications in industrial environment as well as in residential, commercial and light industry environment without any restrictions. A detailed EMC report is available on request.

EMC Immunity	According generic standards: EN 61000-6-1 and EN 61000-6-2			
Electrostatic discharge	EN 61000-4-2	contact discharge	8kV	Criterion A
		air discharge	15kV	Criterion A
Electromagnetic RF field	EN 61000-4-3	80MHz-2.7GHz	10V/m	Criterion A
Fast transients (Burst)	EN 61000-4-4	input lines	4kV	Criterion A
		output lines	2kV	Criterion A
		DC-OK signal (coupling clamp)	1kV	Criterion A
Surge voltage on input	EN 61000-4-5	L → N	2kV	Criterion A
		L → PE, N → PE	4kV	Criterion A
Surge voltage on output	EN 61000-4-5	+ → -	1kV	Criterion A
		+ / - → PE	1kV	Criterion A
Surge voltage on DC-OK	EN 61000-4-5	DC-OK signal → PE	1kV	Criterion A
Conducted disturbance	EN 61000-4-6	0.15-80MHz	10V	Criterion A
Mains voltage dips	EN 61000-4-11	0% of 100Vac	0Vac, 20ms	Criterion A
		40% of 100Vac	40Vac, 200ms	Criterion C
		70% of 100Vac	70Vac, 500ms	Criterion A
		0% of 200Vac	0Vac, 20ms	Criterion A
		40% of 200Vac	80Vac, 200ms	Criterion A
		70% of 200Vac	140Vac, 500ms	Criterion A
Voltage interruptions	EN 61000-4-11	0% of 200Vac (=0V)	5000ms	Criterion C
Voltage sags	SEMI F47	dips on the input voltage according to SEMI F47 standard		
		80% of 120Vac (96Vac)	1000ms	Criterion A
		70% of 120Vac (84Vac)	500ms	Criterion A
		50% of 120Vac (60Vac)	200ms	Criterion A
Powerful transients	VDE 0160	over entire load range	750V, 1.3ms	Criterion C

Criteria:

- A:** Power supply shows normal operation behavior within the defined limits.
- C:** Temporary loss of function is possible. Power supply may shut-down and restarts by itself. No damage or hazards for the power supply will occur.

EMC Emission	According generic standards: EN 61000-6-3 and EN 61000-6-4		
Conducted emission input lines	EN 55011, EN 55032, FCC Part 15, CISPR 11, CISPR 32	Class B	
Conducted emission output lines (**)	IEC/CISPR 16-1-2, IEC/CISPR 16-2-1	limits for DC power port acc. EN 61000-6-3 not fulfilled (***)	
Radiated emission	EN 55011, EN 55032	Class B	
Harmonic input current	EN 61000-3-2	fulfilled for class A equipment	
Voltage fluctuations, flicker	EN 61000-3-3	fulfilled *)	

This device complies with FCC Part 15 rules.

Operation is subjected to following two conditions: (1) this device may not cause harmful interference, and (2) this device must accept any interference received, including interference that may cause undesired operation.

*) tested with constant current loads, non pulsing
 **) for information only, not mandatory for EN 61000-6-3
 ***) Quasi-peak values fulfilled, average values +5dB

Switching Frequencies	The power supply has four converters with four different switching frequencies included. One is nearly constant. The others are input voltage and load dependent.	
Switching frequency 1	100kHz	Resonant converter, nearly constant
Switching frequency 2	110kHz to 500kHz	Boost converter, input voltage and load dependent
Switching frequency 3	73kHz to 114kHz	PFC converter, input voltage and load dependent
Switching frequency 4	35kHz to 45kHz	Aux. converter, input voltage and load dependent

15. ENVIRONMENT

Operational temperature *)	-25°C to +70°C	reduce output power according Fig. 15-1
Storage temperature	-40 to +85°C	for storage and transportation
Output derating	12W/°C	60-70°C
Humidity **)	5 to 95% r.H.	IEC 60068-2-30
Vibration sinusoidal	2-17.8Hz: ±1.6mm; 17.8-500Hz: 2g 2 hours / axis	IEC 60068-2-6
Shock	15g 6ms, 10g 11ms 3 bumps / direction, 18 bumps in total	IEC 60068-2-27, DIN rail mounting
	30g 6ms, 20g 11ms 3 bumps / direction, 18 bumps in total	IEC 60068-2-27, with wall mounting bracket ZM2.WALL
Altitude	0 to 2000m	without any restrictions
	2000 to 6000m	reduce output power or ambient temperature, see Fig. 15-2 IEC 62103, EN 50178, overvoltage category II
Altitude derating	30W/1000m or 5°C/1000m	> 2000m, see Fig. 15-2
Over-voltage category	III	IEC 62103, EN 50178, altitudes up to 2000m
	II	altitudes from 2000m to 6000m
Degree of pollution	2	IEC 62103, EN 50178, not conductive

*) Operational temperature is the same as the ambient temperature and is defined as the air temperature 2cm below the unit.

***) Do not energize while condensation is present

Fig. 15-1 Output current vs. ambient temp.

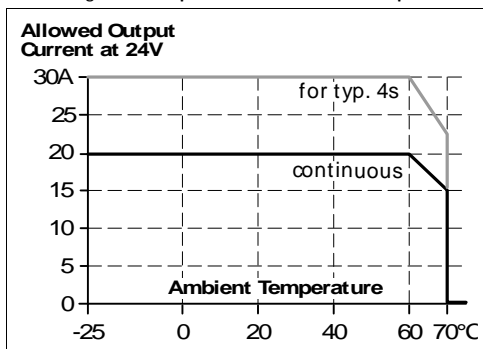
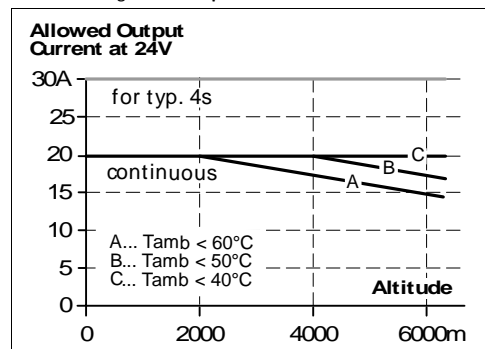

Fig. 15-2 Output current vs. altitude



16. PROTECTION FEATURES

Output protection	Electronically protected against overload, no-load and short-circuits *)	
Output over-voltage protection	typ. 32Vdc max. 37Vdc	In case of an internal power supply defect, a redundant circuit limits the maximum output voltage. The output shuts down and automatically attempts to restart.
Degree of protection	IP 20	EN/IEC 60529
Penetration protection	> 3.5mm / > 5mm	top side / bottom side, e.g. screws, small parts
Over-temperature protection	yes	Output shut-down with automatic restart
Input transient protection	MOV (Metal Oxide Varistor)	
Internal input fuse	included	not user replaceable

*) In case of a protection event, audible noise may occur.

17. SAFETY FEATURES

Input / output separation *)	SELV PELV double or reinforced insulation	IEC/EN 60950-1 IEC/EN 60204-1, EN 50178, IEC 62103, IEC 60364-4-41
Class of protection	I	PE (Protective Earth) connection required
Isolation resistance	> 5MΩ	input to output, 500Vdc
PE resistance	< 0.10Ω	
Touch current (leakage current)	typ. 0.23mA / 0.63mA typ. 0.34mA / 0.93mA typ. 0.58mA / 1.56mA < 0.31mA / 0.77mA < 0.45mA / 1.13mA < 0.80mA / 2.00mA	100Vac, 50Hz, TN-,TT-mains / IT-mains 120Vac, 60Hz, TN-,TT-mains / IT-mains 230Vac, 50Hz, TN-,TT-mains / IT-mains 110Vac, 50Hz, TN-,TT-mains / IT-mains 132Vac, 60Hz, TN-,TT-mains / IT-mains 264Vac, 50Hz, TN-,TT-mains / IT-mains

*) double or reinforced insulation

18. DIELECTRIC STRENGTH

The output voltage is floating and has no ohmic connection to the ground. Type and factory tests are conducted by the manufacturer. Field tests may be conducted in the field using the appropriate test equipment which applies the voltage with a slow ramp (2s up and 2s down). Connect all input-terminals together as well as all output poles before conducting the test. When testing, set the cut-off current settings to the value in the table below.

Fig. 18-1 Dielectric strength

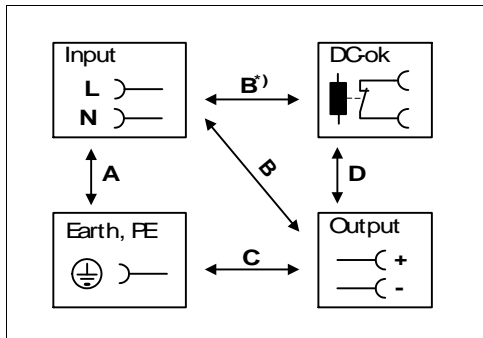

		A	B	C	D
Type test	60s	2500Vac	3000Vac	500Vac	500Vac
Factory test	5s	2500Vac	2500Vac	500Vac	500Vac
Field test	5s	2000Vac	2000Vac	500Vac	500Vac
Cut-off current setting		> 15mA	> 15mA	> 40mA	> 1mA

To fulfil the PELV requirements according to EN60204-1 § 6.4.1, we recommend that either the + pole, the – pole or any other part of the output circuit shall be connected to the protective earth system. This helps to avoid situations in which a load starts unexpectedly or can not be switched off when unnoticed earth faults occur.

B*) When testing input to DC-OK ensure that the max. voltage between DC-OK and the output is not exceeded (column D). We recommend connecting DC-OK pins and the output pins together when performing the test.

19. APPROVED, FULFILLED OR TESTED STANDARDS

UL 508		<p>UL Certificate Listed equipment for category NMTR - Industrial Control Equipment Applicable for US and Canada E-File: E198865</p>
IEC 61010-2-201		<p>Manufacturer's Declaration Electrical Equipment for Measurement, Control and Laboratory Use - Particular requirements for control equipment</p>
IEC 60950-1		<p>CB Scheme Certificate General safety requirements for Information Technology Equipment (ITE)</p>
IEC 62368-1		<p>CB Scheme Certificate IEC 62368-1 Audio/video, information and communication technology equipment - Safety requirements Output safety level: ES1</p>
UL 60950-1		<p>UL Certificate Recognized component for category QQQQ - Information Technology Equipment (ITE) Applicable for US and Canada E-File: E137006</p>
ATEX (only QS20.241-A1)		<p>Agency Certificate (Bureau Veritas) EN 60079-0 Explosive atmospheres - General requirements EN 60079-7, EN 60079-15 Equipment protection by type of protection "e" and "n" Certificate: EPS 09 ATEX 1 236 X Temperature Code: T3 Type of Protection: ec nC</p>
IECEx (only QS20.241-A1)		<p>IECEx Certificate IEC 60079-0 Explosive atmospheres - General requirements IEC 60079-7, IEC 60079-15 Equipment protection by type of protection "e" and "n" Certificate: IECEx EPS 12.0031X Temperature Code: T3 Type of Protection: ec nC</p>
Class I Div 2		<p>CSA Certificate Power Supplies for Hazardous Location Applicable for Canada and US CSA Class: 5318-01 (Canada), 5318-81 (USA) Temperature Code: T3 Groups: A, B, C and D</p>
Marine (DNV) (only QS20.241, QS20.241-C1)		<p>DNV Certificate DNV Type approved product Certificate: TAA00001ST Temperature: Class D Humidity: Class B Vibration: Class C EMC: Class A Enclosure: Class A</p>

Marine (DNV)
(only QS20.241-A1)



DNV Certificate
DNV Type approved product
Certificate: TAA00002YX
Temperature: Class D
Humidity: Class B
Vibration: Class C
EMC: Class A
Enclosure: Class A

Marine (ABS)
(only QS20.241, QS20.241-C1)



ABS Design Assessment Certificate
ABS (American Bureau of Shipment) assessed product
Certificate: 22-2231447-PDA

IEC 61558-2-16
(only QS20.241)



Test Certificate
Safety of transformers, reactors, power supply units and similar products for supply voltages up to 1100 V
Particular requirements and tests for switch mode power supply units and transformers for switch mode power supply units

SEMI F47



Test Report
Voltage Sag Immunity for Semiconductor Processing Equipment
Tested for AC 120V and 208V L-L or L-N mains voltages, nominal output voltage and nominal output load

IEC 60068-2-60
(only QS20.241, QS20.241-A1)



Manufacturer's Declaration (Online Document)
Environmental Tests, Flowing Mixed Gas Corrosion Test
Test Ke - Method 4
H2S: 10ppb
NO2: 200ppb
Cl2: 10ppb
SO2: 200ppb
Test Duration: 3 weeks, which simulates a service life of 10 years.

ISA-71.04-1985
(only QS20.241, QS20.241-A1)



Manufacturer's Declaration (Online Document)
Airborne Contaminants Corrosion Test
Severity Level: G3 Harsh
H2S: 100ppb
NOx: 1250ppb
Cl2: 20ppb
SO2: 300ppb
Test Duration: 3 weeks, which simulates a service life of 10 years.

VDMA 24364



Paint Wetting Impairment Substances Test (or LABS-Test)
Tested for Zone 2 and test class C1 according to VDMA 24364-C1-L/W for solvents and water-based paints

20. REGULATORY PRODUCT COMPLIANCE

EU Declaration of Conformity



The CE mark indicates conformance with the

- EMC directive
- Low-voltage directive (LVD) (only QS20.241, QS20.241-C1)
- RoHS directive
- ATEX directive (only QS20.241-A1)

REACH Regulation (EU)



Manufacturer's Declaration

EU regulation regarding the Registration, Evaluation, Authorisation and Restriction of Chemicals (REACH) fulfilled.

EU Regulation (EC) 1907/2006.

WEEE Regulation



Manufacturer's Declaration

EU Regulation on Waste Electrical and Electronic Equipment

Registered as business to business (B2B) products.

EU Regulation 2012/19/EU

UKCA



UKCA Declaration of Conformity

Trade conformity assessment for England, Scotland and Wales

The UKCA mark indicates conformity with the UK Statutory Instruments

2016 No.1101 (only QS20.241, QS20.241-C1),

2016 No. 1107 (only QS20.241-A1)

2016 No.1091,

2012 No.3032

CCC

(only QS20.241-A1)



CCC Certificate

China Compulsory Certification (CNCA-C23-01:2019)

Certificate for devices made in Suzhou/China (PULS Electronics):

2021122303114740

Certificate for devices made in Chomutov/Czech Republic (PULS investiční):

2021122303114741

CCC-Ex

KC



KC Korean Certification

Korean - Registration of Broadcasting and Communication Equipment

Registered under Clause3, Article 58-2 of Radio Waves Act.

Registration No. R-R-PUG-QS20_241.

21. PHYSICAL DIMENSIONS AND WEIGHT

Weight	1200g
DIN rail	Use 35mm DIN rails according to EN 60715 or EN 50022 with a height of 7.5 or 15mm. The DIN rail depth must be added to the unit depth (127mm) to calculate the total required installation depth.
Installation Clearances	See chapter 2

Fig. 21-1 Front view

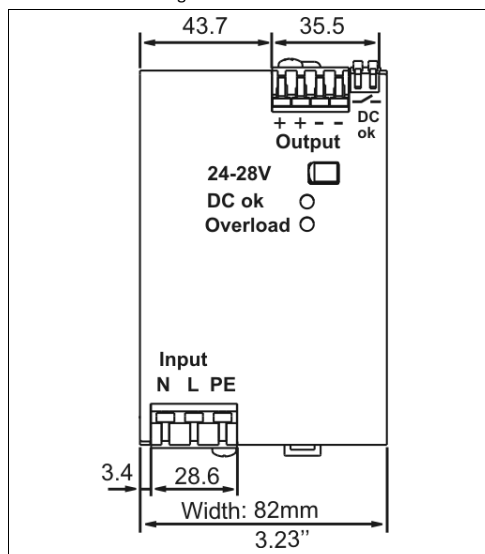
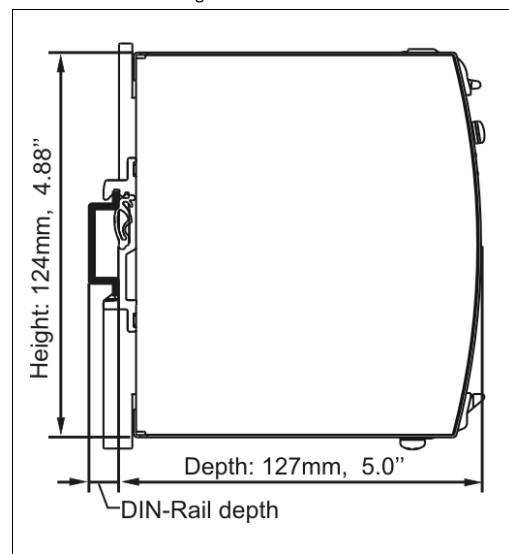

Fig. 21-2 Side view



22. ACCESSORIES

22.1. ZM2.WALL-WALL MOUNTING BRACKET

This bracket is used to mount the power supply onto a flat surface without utilizing a DIN rail.

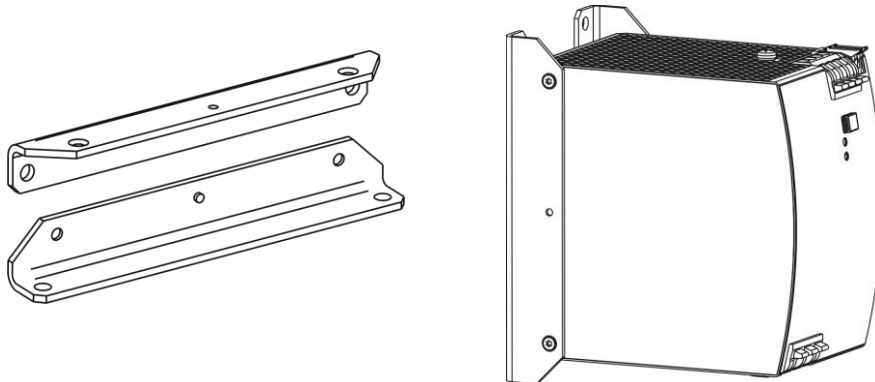

22.2. ZM15.SIDE-SIDE MOUNTING BRACKET

This bracket is used to mount Dimension units sideways with or without utilizing a DIN rail. The two aluminum brackets and the black plastic slider of the unit have to be detached, so that the steel brackets can be mounted.

For sideways DIN rail mounting, the removed aluminum brackets and the black plastic slider need to be mounted on the steel bracket.

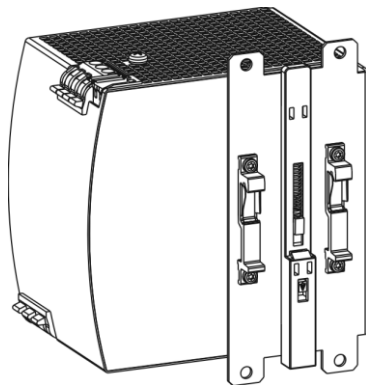

Side mounting with DIN rail brackets

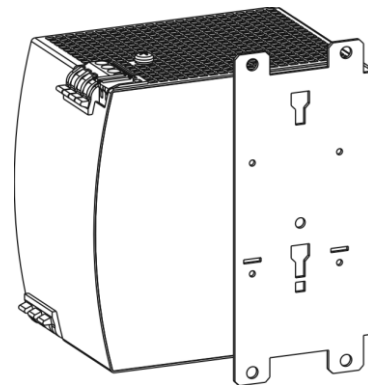

Side mounting without DIN rail brackets

22.3. -YR40.242 - REDUNDANCY MODULES

(2x 20A Inputs, 1x 40A output)



The YR40.242 is equipped with two input channels, which are individually decoupled by utilizing mosfet technology. Using mosfets instead of diodes reduces the heat generation and the voltage drop between input and output. The YR40.242 does not require an additional auxiliary voltage and is self-powered even in case of a short circuit across the output.

Due to the low power losses, the unit is very slender and only requires 36mm width on the DIN rail.

22.4. YR40.245 - REDUNDANCY MODULES

(1x 40A input, 1x 40A output)



The YR40.245 is a 40A single channel redundancy module, which is equipped with a plug connector on the output. The plug connector allows replacing the power supply or the redundancy module while the system is running. The plug connector avoids that the output wires can touch and short the load circuit.

The YR40.245 is very slender and only requires 46mm width on the DIN rail. It also utilizes mosfet technology instead of diodes for low heat generation and a minimal voltage drop between input and output. It does not require an additional auxiliary voltage and is self-powered even in case of a short circuit across the output.

Fig. 22-1 Typical 1+1 Redundant configuration for 20A with a dual redundancy module

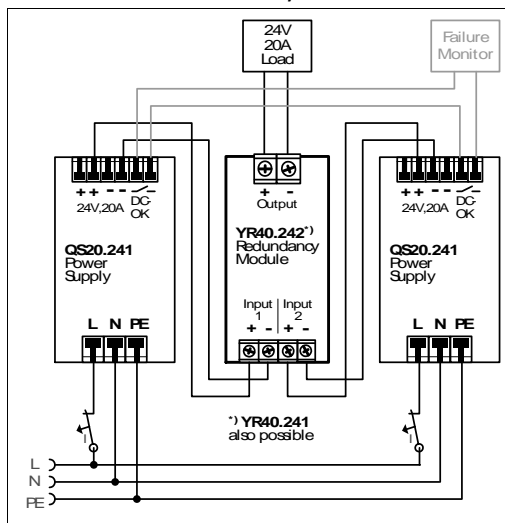
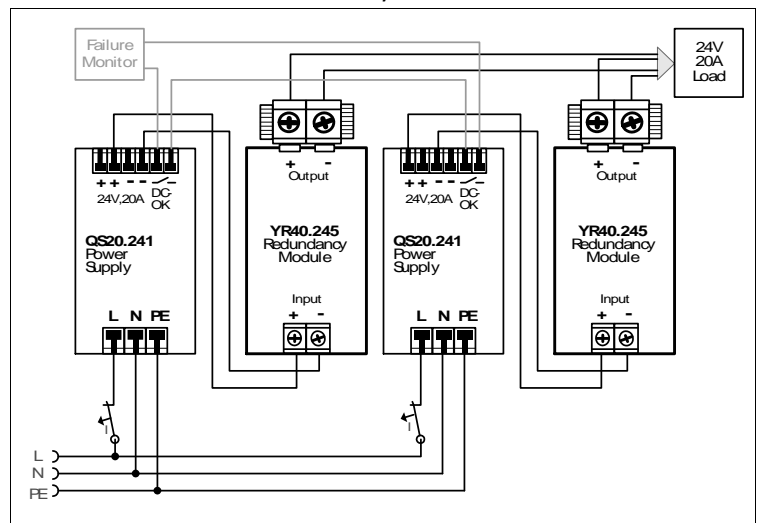

Fig. 22-2 Typical N+1 or 1+1 Redundant configuration for 20A with multiple YR40.245 redundancy modules



23. APPLICATION NOTES

23.1. REPETITIVE PULSE LOADING

Typically, a load current is not constant and varies over time. This power supply is designed to support loads with a higher short-term power demand (=BonusPower). The short-term duration is hardware controlled by an output power manager and is available on a repeated basis. If the BonusPower load lasts longer than the hardware controller allows it, the output voltage will dip and the next BonusPower is available after the BonusPower recovery time (see chapter 6) has elapsed.

To avoid this, the following rules must be met:

- The power demand of the pulse must be below 150% of the nominal output power.
- The duration of the pulse power must be shorter than the allowed BonusPower time. (see output chapter)
- The average (R.M.S.) output current must be below the specified continuous output current.
If the R.M.S. current is higher, the unit will respond with a thermal shut-down after a period of time. Use the maximum duty cycle curve (Fig. 23-2) to check if the average output current is below the nominal current.

Fig. 23-1 Repetitive pulse loads, definitions

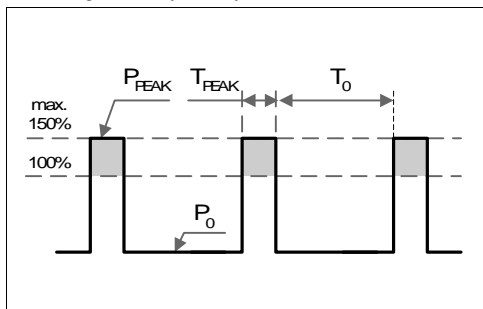

- P_0 Base load (W)
- P_{PEAK} Pulse load (above 100%)
- T_0 Duration between pulses (s)
- T_{PEAK} Pulse duration (s)

Fig. 23-2 Max. duty cycle curve

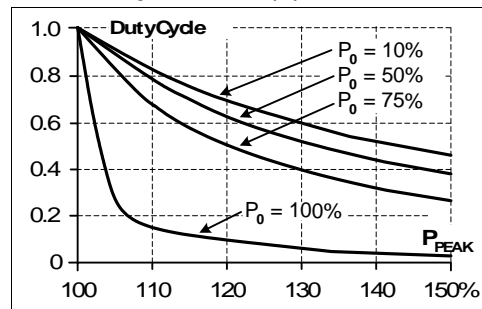

$$\text{DutyCycle} = \frac{T_{\text{peak}}}{T_{\text{peak}} + T_0}$$

$$T_0 = \frac{T_{\text{peak}} - (\text{DutyCycle} \times T_{\text{peak}})}{\text{DutyCycle}}$$

Example: A load is powered continuously with 240W (= 50% of the rated output load). From time to time a peak power of 720W (= 150% of the rated output load) is needed for 1 second.

The question is: How often can this pulse be supplied without overloading the power supply?

- Make a vertical line at $P_{PEAK} = 150\%$ and a horizontal line where the vertical line crosses the $P_0 = 50\%$ curve. Read the max. duty cycle from the duty cycle-axis (= 0.37)
- Calculate the required pause (base load) length T_0 :
- Result: The required pause length = 1.7s
- Max. repetition rate = pulse + pause length = **2.7s**

$$T_0 = \frac{T_{\text{peak}} - (\text{DutyCycle} \times T_{\text{peak}})}{\text{DutyCycle}} = \frac{1\text{s} - (0.37 \times 1\text{s})}{0.37} = \underline{\underline{1.7\text{s}}}$$

More examples for pulse load compatibility:

P_{PEAK}	P_0	T_{PEAK}	T_0
720W	480W	1s	>25s
720W	0W	1s	>1.3s
600W	240W	1s	> 0.75s

P_{PEAK}	P_0	T_{PEAK}	T_0
720W	240W	0.1s	>0.16s
720W	240W	1s	>1.6s
720W	240W	3s	>4.9s

23.2. PEAK CURRENT CAPABILITY

Solenoids, contactors and pneumatic modules often have a steady state coil and a pick-up coil. The inrush current demand of the pick-up coil is several times higher than the steady-state current and usually exceeds the nominal output current (including the PowerBoost). The same situation applies when starting a capacitive load.

Branch circuits are often protected with circuit breakers or fuses. In case of a short or an overload in the branch circuit, the fuse needs a certain amount of over-current to trip or to blow. The peak current capability ensures the safe operation of subsequent circuit breakers.

Assuming the input voltage is turned on before such an event, the built-in large sized output capacitors inside the power supply can deliver extra current. Discharging this capacitor causes a voltage dip on the output. The following two examples show typical voltage dips:

Fig. 23-3 Peak load with 2x the nominal current for 50ms, typ.

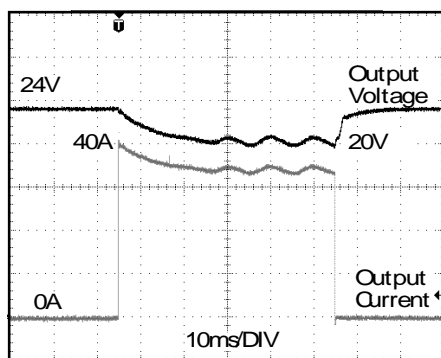

Peak load 40A (resistive) for 50ms
Output voltage dips from 24V to 20V.

Fig. 23-4 Peak load with 5x the nominal current for 5ms, typ.

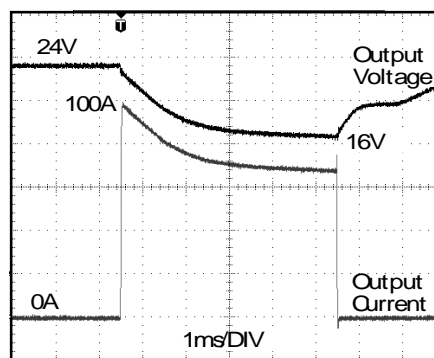

Peak load 100A (resistive) for 5ms
Output voltage dips from 24V to 16V.

Please note: The DC-OK relay triggers when the voltage dips more than 10% for longer than 1ms.

23.3. BACK-FEEDING LOADS

Loads such as decelerating motors and inductors can feed voltage back to the power supply. This feature is also called return voltage immunity or resistance against Back- E.M.F. (Electro Magnetic Force).

This power supply is resistant and does not show malfunctioning when a load feeds back voltage to the power supply. It does not matter whether the power supply is on or off.

The maximum allowed feed-back-voltage is 34Vdc. The absorbing energy can be calculated according to the built-in large sized output capacitor which is specified in chapter 6.

23.4. EXTERNAL INPUT PROTECTION

The unit is tested and approved for branch circuits up to 20A. An external protection is only required if the supplying branch has an ampacity greater than this. Check also local codes and local requirements. In some countries local regulations might apply.

If an external fuse is necessary or utilized, minimum requirements need to be considered to avoid nuisance tripping of the circuit breaker. A minimum value of 10A B- or C-Characteristic breaker should be used

23.5. CHARGING OF BATTERIES

The power supply can be used to charge lead-acid or maintenance free batteries. (Two 12V batteries in series)

Instructions for charging batteries:

- a) Set output voltage (measured at no load and at the battery end of the cable) very precisely to the end-of-charge voltage.

End-of-charge voltage	27.8V	27.5V	27.15V	26.8V
Battery temperature	10°C	20°C	30°C	40°C

- b) Use a 30A or 32A circuit breaker (or blocking diode) between the power supply and the battery.
- c) Ensure that the output current of the power supply is below the allowed charging current of the battery.
- d) Use only matched batteries when putting 12V types in series.
- e) The return current to the power supply (battery discharge current) is typ. 9mA when the power supply is switched off (except in case a blocking diode is utilized).

23.6. OUTPUT CIRCUIT BREAKERS

Standard miniature circuit breakers (MCB's or UL1077 circuit breakers) are commonly used for AC-supply systems and may also be used on 24V branches.

MCB's are designed to protect wires and circuits. If the ampere value and the characteristics of the MCB are adapted to the wire size that is used, the wiring is considered as thermally safe regardless of whether the MCB opens or not.

To avoid voltage dips and under-voltage situations in adjacent 24V branches which are supplied by the same source, a fast (magnetic) tripping of the MCB is desired. A quick shutdown within 10ms is necessary corresponding roughly to the ride-through time of PLC's. This requires power supplies with high current reserves and large output capacitors. Furthermore, the impedance of the faulty branch must be sufficiently small in order for the current to actually flow. The best current reserve in the power supply does not help if Ohm's law does not permit current flow. The following table has typical test results showing which B- and C-Characteristic MCBs magnetically trip depending on the wire cross chapter and wire length.

Fig. 23-5 Test circuit

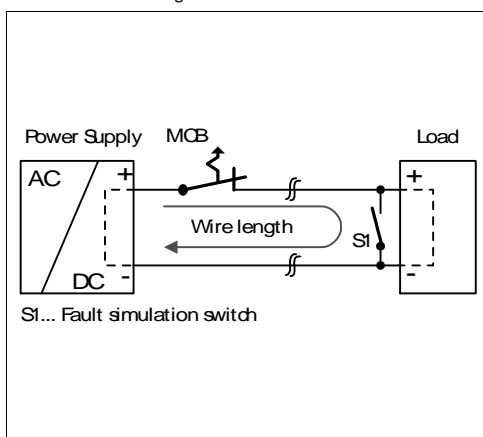

Maximal wire length*) for a fast (magnetic) tripping:

	0.75mm ²	1.0mm ²	1.5mm ²	2.5mm ²
C-2A	26m	35m	62m	82m
C-3A	23m	29m	54m	72m
C-4A	15m	19m	31m	51m
C-6A	7m	10m	15m	26m
C-8A	5m	7m	10m	16m
C-10A	2m	3m	5m	7m
C-13A	-	-	1m	2m
B-6A	19m	27m	38m	57m
B-10A	7m	11m	14m	23m
B-13A	1m	2m	3m	5m

*) Don't forget to consider twice the distance to the load (or cable length) when calculating the total wire length (+ and - wire).

23.7. PARALLEL USE TO INCREASE OUTPUT POWER

Power supplies from the same series (Q-Series) can be paralleled to increase the output power. The output voltage shall be adjusted to the same value ($\pm 100\text{mV}$) with the same load conditions on all units, or the units can be left with the factory settings.

If more than three units are connected in parallel, a fuse or circuit breaker with a rating of 30A or 32A is required on each output. Alternatively, a diode or redundancy module can also be utilized.

Keep an installation clearance of 15mm (left / right) between two power supplies and avoid installing the power supplies on top of each other. Do not use power supplies in parallel in mounting orientations other than the standard mounting orientation (input terminals on bottom and output terminals on the top of the unit) or in any other condition where a derating of the output current is required (e.g. altitude, above 60°C, ...).

Pay attention that leakage current, EMI, inrush current, harmonics will increase when using multiple power supplies.

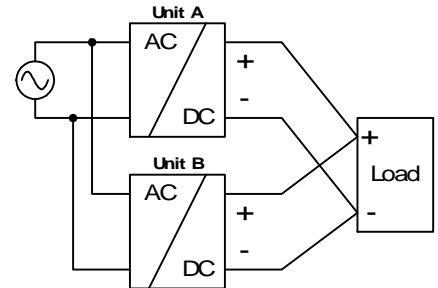

23.8. PARALLEL USE FOR REDUNDANCY

Power supplies can be paralleled for redundancy to gain higher system availability. Redundant systems require a certain amount of extra power to support the load in case one power supply unit fails. The simplest way is to put two power supplies in parallel. This is called a 1+1 redundancy. In case one power supply unit fails, the other one is automatically able to support the load current without any interruption. Redundant systems for a higher power demand are usually built in a N+1 method. E.g. five power supplies, each rated for 20A are paralleled to build an 80A redundant system. For N+1 redundancy the same restrictions apply as for increasing the output power, see also chapter 23.7.

Please note: This simple way to build a redundant system does not cover failures such as an internal short circuit in the secondary side of the power supply. In such a case, the defective unit becomes a load for the other power supplies and the output voltage can not be maintained any more. This can be avoided by utilizing decoupling diodes or Mosfets, which are included in the redundancy module YR40.241 or YR40.242.

Recommendations for building redundant power systems:

- Use separate input fuses for each power supply.
- Monitor the individual power supply units. Therefore, use the DC-OK relay contact of the QS20 power supply.
- It is desirable to set the output voltages of all units to the same value ($\pm 100\text{mV}$) or leave it at the factory setting.

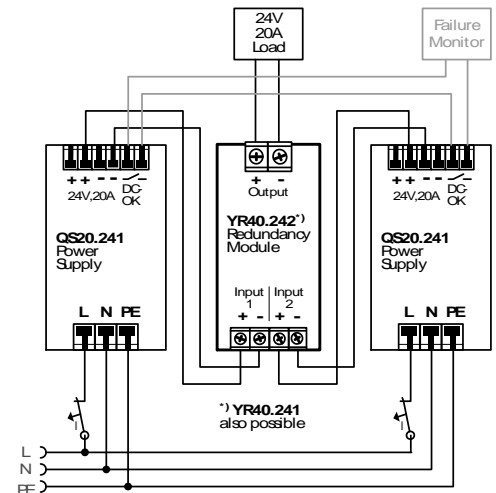

23.9. SERIES OPERATION

Power supplies of the same type can be connected in series for higher output voltages. It is possible to connect as many units in series as needed, providing the sum of the output voltage does not exceed 150Vdc. Voltages with a potential above 60Vdc are not SELV anymore and can be dangerous. Such voltages must be installed with a protection against touching.

Earthing of the output is required when the sum of the output voltage is above 60Vdc.

Avoid return voltage (e.g. from a decelerating motor or battery) which is applied to the output terminals.

Keep an installation clearance of 15mm (left / right) between two power supplies and avoid installing the power supplies on top of each other. Do not use power supplies in series in mounting orientations other than the standard mounting orientation (input terminals on bottom and output terminals on the top of the unit).

Pay attention that leakage current, EMI, inrush current, harmonics will increase when using multiple power supplies.

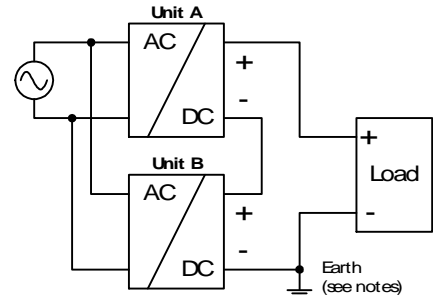

23.10. INDUCTIVE AND CAPACITIVE LOADS

The unit is designed to supply any kind of loads, including unlimited capacitive and inductive loads.

23.11. OPERATION ON TWO PHASES

The power supply can also be used on two-phases of a three-phase-system. Such a phase-to-phase connection is allowed as long as the supplying voltage is below 240V^{+15%}. Use a fuse or a circuit breaker to protect the N input. The N input is internally not protected and is in this case connected to a hot wire. Appropriate fuses or circuit breakers are specified in chapter 23.4 "External Input Protection".

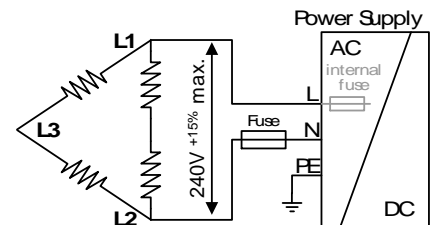

23.12. USE IN A TIGHTLY SEALED ENCLOSURE

When the power supply is installed in a tightly sealed enclosure, the temperature inside the enclosure will be higher than outside. In such situations, the inside temperature defines the ambient temperature for the power supply.

The following measurement results can be used as a reference to estimate the temperature rise inside the enclosure.

The power supply is placed in the middle of the box, no other heat producing items are inside the box

Enclosure:	Rittal Typ IP66 Box PK 9522 100, plastic, 254x180x165mm
Load:	24V, 16A; (=80%) load is placed outside the box
Input:	230Vac
Temperature inside enclosure:	49.2°C (in the middle of the right side of the power supply with a distance of 2cm)
Temperature outside enclosure:	24.4°C
Temperature rise:	24.8K

23.13. MOUNTING ORIENTATIONS

Mounting orientations other than input terminals on the bottom and output on the top require a reduction in continuous output power or a limitation in the maximum allowed ambient temperature. The amount of reduction influences the lifetime expectancy of the power supply. Therefore, two different derating curves for continuous operation can be found below:

Curve A1 Recommended output current.

Curve A2 Max. allowed output current (results in approximately half the lifetime expectancy of A1).

Fig. 23-6
Mounting
Orientation A
(Standard
orientation)

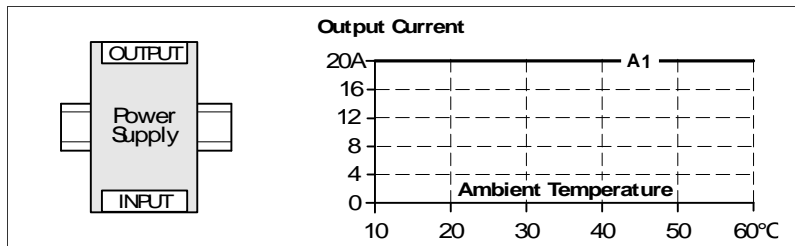

Fig. 23-7
Mounting
Orientation B
(Upside down)

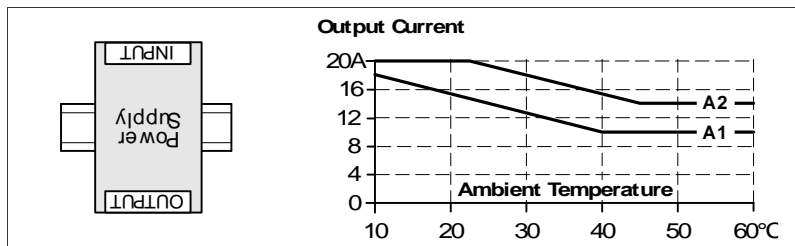

Fig. 23-8
Mounting
Orientation C
(Table-top
mounting)

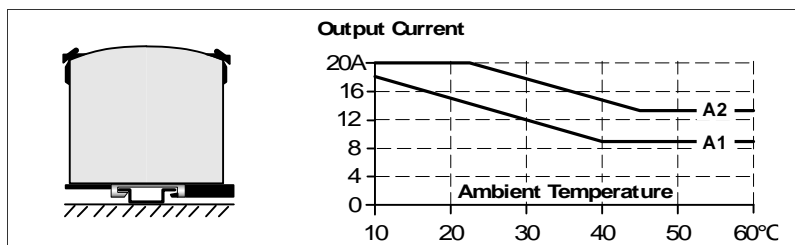

Fig. 23-9
Mounting
Orientation D
(Horizontal cw)

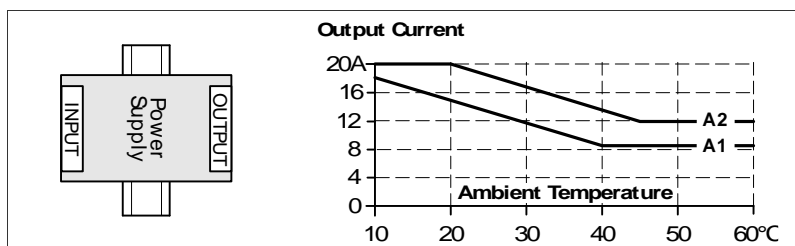
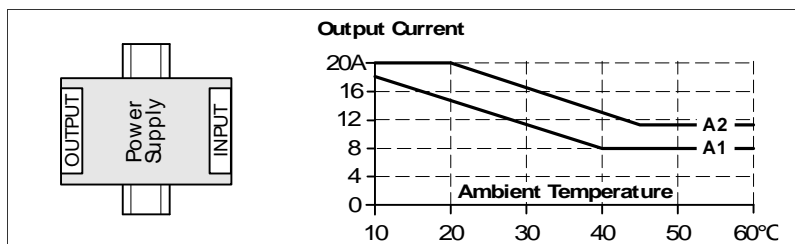



Fig. 23-10
Mounting
Orientation E
(Horizontal ccw)







Looking for pricing, stock, or lifecycle information?

Click below to explore more details on WIN SOURCE:

-  [View QS20.241 on WIN SOURCE](#)
-  [PULS, LP Information](#)

Optimize Your Supply Chain with WIN SOURCE Solutions

-  Global Sourcing Solution
-  Obsolete Management
-  Cost Control Management
-  Shortage Management
-  Alternative Solution
-  Excess Inventory Management