



**THE DATASHEET OF
TC74LVX4245FS(EL,F**



TOSHIBA CMOS DIGITAL INTEGRATED CIRCUIT SILICON MONOLITHIC

TC74LVX4245FS**OCTAL DUAL SUPPLY BUS TRANSCEIVER**

The TC74LVX4245 is a dual supply, advanced high speed CMOS OCTAL BUS TRANSCEIVER fabricated with silicon gate CMOS technology.

Designed for use as an interface between a 5V bus and a 3.3V bus in mixed 5V/3.3V supply systems' it achieves high speed operation while maintaining the CMOS low power dissipation.

It is intended for 2 way asynchronous communication between data busses. The direction of data transmission is determined by the level of the DIR input.

The enable input (\overline{OE}) can be used to disable the device so that the busses are effectively isolated.

The A-port interfaces with the 5V bus, the B-port with the 3.3V bus.

All inputs are equipped with protection circuits against static discharge or transient excess voltage.

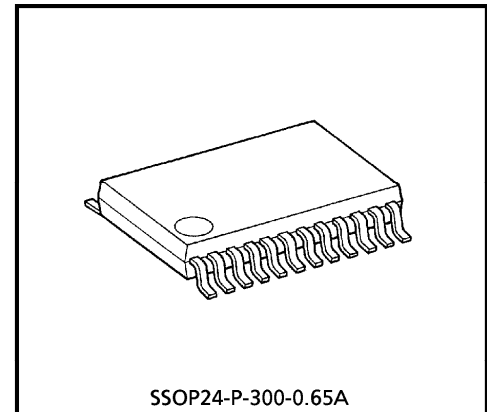

Weight : 0.14g (Typ.)

FEATURES

- Bidirectional interface between 5V and 3V buses
- High speed : $t_{pd} = 6.0\text{ns}$ (Typ.)
($V_{CCA} = 5.0\text{V} / V_{CCB} = 3.3\text{V}$)
- Low power dissipation : $I_{CC} = 8\mu\text{A}$ (Max.) ($T_a = 25^\circ\text{C}$)
- Symmetrical output impedance : $I_{OUTA} = \pm 24\text{mA}$ (Min.)
 $I_{OUTB} = \pm 12\text{mA}$ (Min.)
($V_{CCA} = 4.5\text{V} / V_{CCB} = 3.0\text{V}$)
- Low noise : $V_{OLP} = 1.5\text{V}$ (Max.)
- Available in SSOP package

APPLICATION NOTES

Do not apply a signal to any bus terminal when it is in the output mode. Damage may result.

All floating (high impedance) bus terminals must have their input levels fixed by means of pull up or pull down resistors.

961001EBA2

- TOSHIBA is continually working to improve the quality and the reliability of its products. Nevertheless, semiconductor devices in general can malfunction or fail due to their inherent electrical sensitivity and vulnerability to physical stress. It is the responsibility of the buyer, when utilizing TOSHIBA products, to observe standards of safety, and to avoid situations in which a malfunction or failure of a TOSHIBA product could cause loss of human life, bodily injury or damage to property. In developing your designs, please ensure that TOSHIBA products are used within specified operating ranges as set forth in the most recent products specifications. Also, please keep in mind the precautions and conditions set forth in the TOSHIBA Semiconductor Reliability Handbook.

PIN ASSIGNMENT

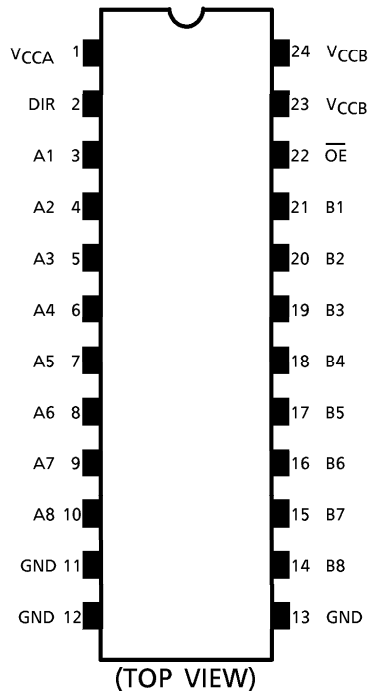

IEC LOGIC SYMBOL

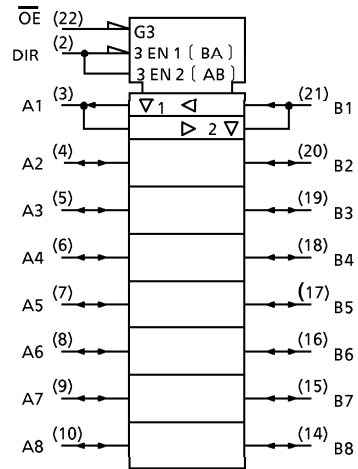

TRUTH TABLE

INPUTS		OUTPUTS	FUNCTION	
\overline{G}	DIR		A-BUS	B-BUS
L	L	A = B	OUTPUT	INPUT
L	H	B = A	INPUT	OUTPUT
H	X	Z	High Impedance	

X : Don't Care
 Z : High Impedance

961001EBA2'

- The products described in this document are subject to foreign exchange and foreign trade control laws.
- The information contained herein is presented only as a guide for the applications of our products. No responsibility is assumed by TOSHIBA CORPORATION for any infringements of intellectual property or other rights of the third parties which may result from its use. No license is granted by implication or otherwise under any intellectual property or other rights of TOSHIBA CORPORATION or others.
- The information contained herein is subject to change without notice.

BLOCK DIAGRAM

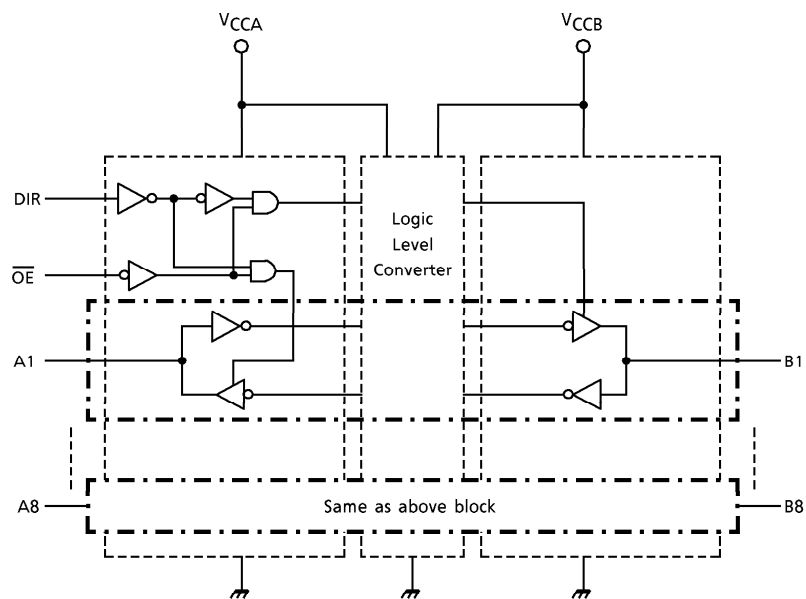

MAXIMUM RATINGS

PARAMETER	SYMBOL	RATING	UNIT
Supply Voltage Range*	V_{CCA}	-0.5~7.0	V
	V_{CCB}	-0.5~ V_{CCA}	
DC Input Voltage (\overline{OE}, DIR)	V_{IN}	-0.5~ $V_{CCA} + 0.5$	V
DC Bus I/O Voltage	$V_{I/OA}$	-0.5~ $V_{CCA} + 0.5$	V
	$V_{I/OB}$	-0.5~ $V_{CCB} + 0.5$	
Input Diode Current	I_{IK}	-20	mA
Output Diode Current	I_{OK}	± 50	mA
DC Output Current	I_{OUTA}	± 50	mA
	I_{OUTB}	± 50	
DC V_{CC} / Ground Current	I_{CCA}	± 200	mA
	I_{CCB}	± 100	
Power Dissipation	P_D	180	mW
Storage Temperature	T_{stg}	-65~150	$^{\circ}C$

* : $V_{CCA} > V_{CCB}$, Don't use under the condition that V_{CCB} is 0V.

RECOMMENDED OPERATING CONDITIONS

PARAMETER	SYMBOL	RATING	UNIT
Supply Voltage	V_{CCA}	4.5~5.5	V
	V_{CCB}	2.7~3.6	
Input Voltage (\overline{OE} ,DIR)	V_{IN}	0~ V_{CCA}	V
Bus I/O Voltage	$V_{I/OA}$	0~ V_{CCA}	V
	$V_{I/OB}$	0~ V_{CCB}	
Operating Temperature	T_{opr}	-40~85	°C
Input Rise And Fall Time	dt/dv	0~8 ($V_{CCA} = 4.5\sim 5.5V$)	ns/V
		0~8 ($V_{CCB} = 2.7\sim 3.6V$)	

ELECTRICAL CHARACTERISTICS

DC characteristics (V_{CCA}) $V_{CCB} = 2.7 \sim 3.6V$

PARAMETER		SYM-BOL	TEST CONDITION		V_{CCA} (V)	Ta = 25°C			Ta = -40~85°C		UNIT
						MIN.	TYP.	MAX.	MIN.	MAX.	
Input Voltage	"H" Level	V_{IHA}	DIR, \bar{G} , An		4.5 ~ 5.5	2.0	—	—	2.0	—	V
	"L" Level	V_{ILA}	DIR, \bar{G} , An		4.5 ~ 5.5	—	—	0.8	—	0.8	
Output Voltage	"H" Level	V_{OHA}	$V_{INA} = V_{IHA}$ or V_{ILA} $V_{INB} = V_{IHB}$ or V_{ILB}	$I_{OH} = -100\mu A$	4.5	4.4	4.5	—	4.4	—	V
				$I_{OH} = -24mA$	4.5	3.86	—	—	3.76	—	
	"L" Level	V_{OLA}	$V_{INA} = V_{IHA}$ or V_{ILA} $V_{INB} = V_{IHB}$ or V_{ILB}	$I_{OL} = 100\mu A$	4.5	—	0.0	0.1	—	0.1	
				$I_{OL} = 24mA$	4.5	—	—	0.36	—	0.44	
3-State Output Off-State Current		I_{OZA}	$V_{INA} = V_{IHA}$ or V_{ILA} $V_{INB} = V_{IHB}$ or V_{ILB} $V_{I/OA} = V_{CCA}$ or GND		5.5	—	—	± 0.5	—	± 5.0	μA
Input Leakage Current		I_{INA}	$V_{IN} (DIR, \bar{G}) = V_{CCA}$ or GND		5.5	—	—	± 0.1	—	± 1.0	μA
Quiescent Supply Current		I_{CCA}	$V_{INA} = V_{CCA}$ or GND $V_{INB} = V_{CCB}$ or GND		5.5	—	—	8.0	—	80.0	μA
		I_{CCTA}	PER INPUT : $V_{INA} = 3.4V$ OTHER INPUT : V_{CCA} or GND		5.5	—	—	2.3	—	2.5	mA

DC characteristics (V_{CCB}) $V_{CCA} = 4.5 \sim 5.5V$

PARAMETER		SYM-BOL	TEST CONDITION	V_{CCB} (V)	Ta = 25°C			Ta = -40~85°C		UNIT	
					MIN.	TYP.	MAX.	MIN.	MAX.		
Input Voltage	"H" Level	V_{IHB}	Bn	2.7	2.0	—	—	2.0	—	V	
				3.6	2.2	—	—	2.2	—		
	"L" Level	V_{ILB}	Bn	2.7	—	—	0.8	—	0.8		
				3.6	—	—	0.8	—	0.8		
Output Voltage	"H" Level	V_{OHB}	$V_{INA} = V_{IHA}$ or V_{ILA}	$I_{OH} = -100\mu A$	3.0	2.9	3.0	—	2.9	—	V
				$I_{OH} = -8mA$	2.7	2.26	—	—	2.20	—	
				$I_{OH} = -12mA$	3.0	2.48	—	—	2.40	—	
	"L" Level	V_{OLB}	$V_{INA} = V_{IHA}$ or V_{ILA}	$I_{OL} = 100\mu A$	3.0	—	0.0	0.1	—	0.1	
				$I_{OL} = 8mA$	2.7	—	—	0.31	—	0.40	
				$I_{OL} = 12mA$	3.0	—	—	0.31	—	0.40	
3-State Output Off-State Current		I_{OZB}	$V_{INA} = V_{IHA}$ or V_{ILA} $V_{I/OB} = V_{CCB}$ or GND	3.6	—	—	± 0.5	—	± 5.0	μA	
Quiescent Supply Current		I_{CCB}	$V_{INA} = V_{CCA}$ or GND $V_{INB} = V_{CCB}$ or GND	3.6	—	—	5.0	—	50.0	μA	
		I_{CCTB}	PER INPUT : $V_{INB} = 3.0V$ OTHER INPUT : V_{CCB} or GND	3.6	—	—	0.35	—	0.50	mA	

AC characteristics (Input $t_r = t_f = 3\text{ns}$, $C_L = 50\text{pF}$, $R_L = 500\Omega$, $V_{CCA} = 5.0 \pm 0.5\text{V}$)

PARAMETER	SYMBOL	TEST CONDITION	Ta = 25°C			Ta = -40~85°C		UNIT	
			V _{CCB} (V)	MIN.	TYP.	MAX.	MIN.		MAX.
Propagation Delay Time (An⇒Bn)	t _{pLH}	Input : An Output : Bn (DIR = "H")	2.7	—	7.1	9.5	1.0	10.5	ns
	t _{pHL}		3.3 ± 0.3	—	6.5	8.6	1.0	9.5	
3-State Output Enable Time (\bar{G} ⇒Bn)	t _{pZL}		2.7	—	9.5	12.5	1.0	13.8	ns
	t _{pZH}		3.3 ± 0.3	—	8.6	11.4	1.0	12.5	
3-State Output Disable Time (\bar{G} ⇒Bn)	t _{pLZ}		2.7	—	5.3	9.1	1.0	10.0	ns
	t _{pHZ}		3.3 ± 0.3	—	5.3	9.1	1.0	10.0	
Propagation Delay Time (Bn⇒An)	t _{pLH}	Input : Bn Output : An (DIR = "L")	2.7	—	7.0	9.5	1.0	10.5	ns
	t _{pHL}		3.3 ± 0.3	—	6.4	8.6	1.0	9.5	
3-State Output Enable Time (\bar{G} ⇒An)	t _{pZL}		2.7	—	8.5	11.6	1.0	12.7	ns
	t _{pZH}		3.3 ± 0.3	—	7.7	10.5	1.0	11.5	
3-State Output Disable Time (\bar{G} ⇒An)	t _{pLZ}		2.7	—	5.1	6.8	1.0	7.5	ns
	t _{pHZ}		3.3 ± 0.3	—	5.1	6.8	1.0	7.5	
Output To Output Skew	t _{osLH}	(Note 1)	2.7	—	—	1.5	—	1.5	ns
	t _{osHL}		3.3 ± 0.3	—	—	1.5	—	1.5	
Input Capacitance	C _{INA}	DIR, \bar{G}	3.3 ± 0.3	—	5	10	—	10	pF
Bus Input Capacitance	C _{I/O}	An, Bn	3.3 ± 0.3	—	13	—	—	—	pF
Power Dissipation Capacitance (Note 2)	C _{pDA}	A⇒B (DIR = "H")	3.3 ± 0.3	—	17	—	—	—	pF
		B⇒A (DIR = "L")	3.3 ± 0.3	—	25	—	—	—	
	C _{pDB}	A⇒B (DIR = "H")	3.3 ± 0.3	—	4	—	—	—	
		B⇒A (DIR = "L")	3.3 ± 0.3	—	4	—	—	—	

(Note 1) Parameter guaranteed by design.

$$(t_{osLH} = |t_{pLHm} - t_{pLHn}|, t_{osHL} = |t_{pHLm} - t_{pHLn}|)$$

(Note 2) C_{pD} is defined as the value of the internal equivalent capacitance which is calculated from the operating current consumption without load.

Average operating current can be obtained by the equation :

$$I_{CC}(\text{opr.}) = C_{pD} \cdot V_{CC} \cdot f_{IN} + I_{CC}/8 \text{ (per bit)}$$

Noise characteristics (Ta = 25°C, Input $t_r = t_f = 3\text{ns}$, $C_L = 50\text{pF}$, $R_L = 500\Omega$)

PARAMETER	SYMBOL	TEST CONDITION	VCC (V)		TYP.	LIMIT	UNIT
			VCCA (V)	VCCB (V)			
Quiet Output Maximum Dynamic $V_{OL(A)}$	V_{OLPA}	Input : Bn Output : An (DIR = "L")	5.0	3.3	1.0	1.5	V
Quiet Output Minimum Dynamic $V_{OL(A)}$	V_{OLVA}		5.0	3.3	-0.6	-1.2	V
Quiet Output Maximum Dynamic $V_{OL(B)}$	V_{OLPB}	Input : An Output : Bn (DIR = "H")	5.0	3.3	0.8	1.2	V
Quiet Output Minimum Dynamic $V_{OL(B)}$	V_{OLVB}		5.0	3.3	-0.5	-0.8	V
Minimum High Level Dynamic Input Voltage	V_{IHDA}	Input : An	5.0	3.3	—	2.0	V
Maximum Low Level Dynamic Input Voltage	V_{ILDA}	Input : An	5.0	3.3	—	0.8	V
Minimum High Level Dynamic Input Voltage	V_{IHDB}	Input : Bn	5.0	3.3	—	2.0	V
Maximum Low Level Dynamic Input Voltage	V_{ILDB}	Input : Bn	5.0	3.3	—	0.8	V

OUTLINE DRAWING
SSOP24-P-300-0.65A

Unit : mm

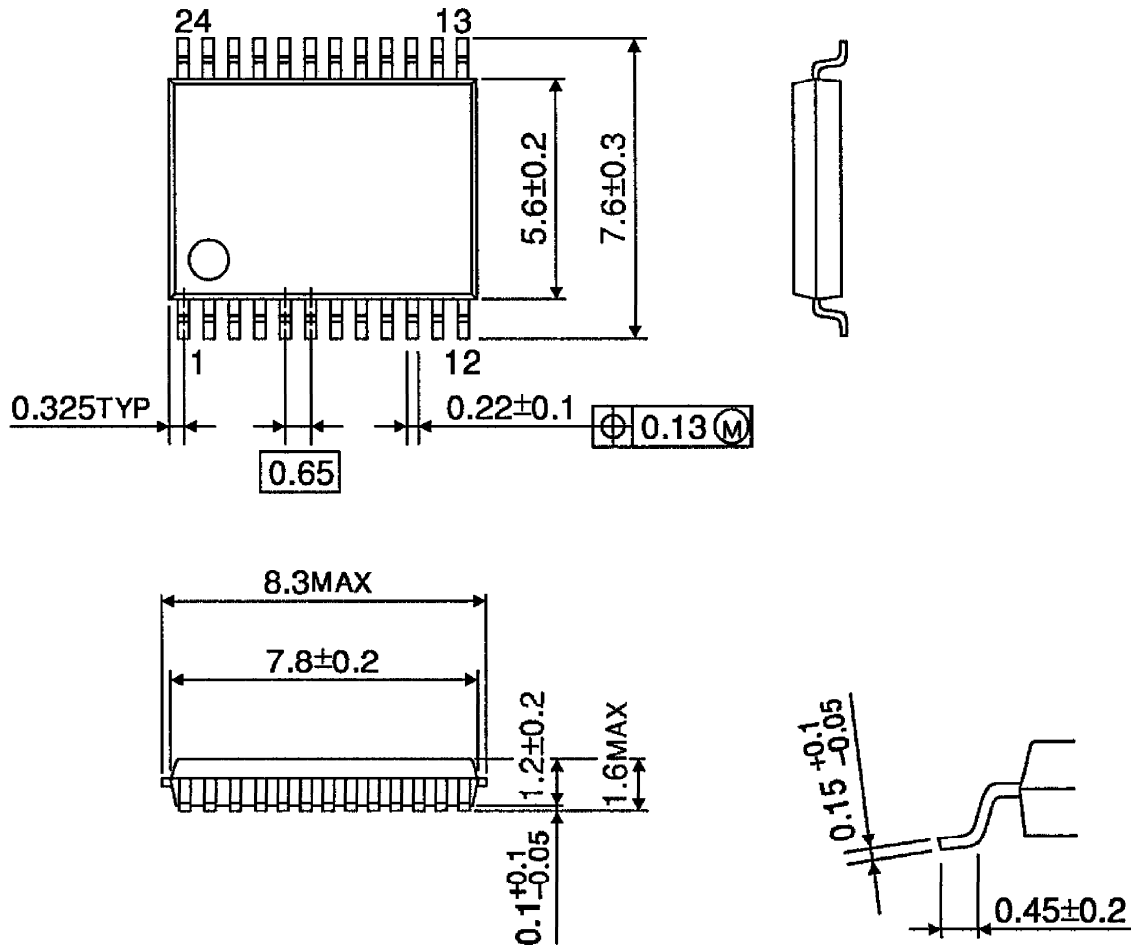

Weight : 0.14g (Typ.)

Looking for pricing, stock, or lifecycle information?

Click below to explore more details on WIN SOURCE:

- ⊖ [View TC74LVX4245FS\(EL,F on WIN SOURCE](#)
- ⊖ [Toshiba Semiconductor and Storage Information](#)

Optimize Your Supply Chain with WIN SOURCE Solutions

- ✓ Global Sourcing Solution
- ✓ Obsolete Management
- ✓ Cost Control Management
- ✓ Shortage Management
- ✓ Alternative Solution
- ✓ Excess Inventory Management