



**THE DATASHEET OF
BFR750L3RHE6327XTSA1**



NPN Silicon Germanium RF Transistor*

- High gain ultra low noise RF transistor
- Provides outstanding performance for a wide range of wireless applications up to 10 GHz
- Ideal for WLAN and all 5-6 GHz applications
- High OIP_3 and P_{-1dB} for driver stages
- High maximum stable and available gain
 $G_{ms} = 21$ dB at 1.8 GHz, $G_{ma} = 11.5$ dB at 6 GHz
- 150 GHz f_T -Silicon Germanium technology
- Extremely small and flat leadless package, reduced height 0.32 mm max.
- Pb-free (RoHS compliant) package¹⁾
- Qualified according AEC Q101

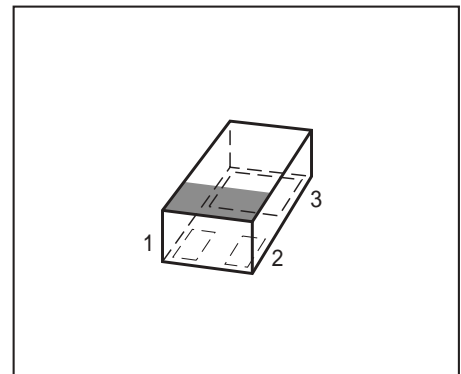

* Short term description



ESD (Electrostatic discharge) sensitive device, observe handling precaution!

Type	Marking	Pin Configuration			Package
BFR750L3RH	R8	1=B	2=C	3=E	TSLP-3-9

¹Pb-containing package may be available upon special request

Maximum Ratings

Parameter	Symbol	Value	Unit
Collector-emitter voltage $T_A > 0^\circ\text{C}$ $T_A \leq 0^\circ\text{C}$	V_{CEO}	4 3.5	V
Collector-emitter voltage	V_{CES}	13	
Collector-base voltage	V_{CBO}	13	
Emitter-base voltage	V_{EBO}	1.2	
Collector current	I_{C}	90	mA
Base current	I_{B}	9	
Total power dissipation ¹⁾ $T_{\text{S}} \leq 96^\circ\text{C}$	P_{tot}	360	mW
Junction temperature	T_{j}	150	$^\circ\text{C}$
Ambient temperature	T_{A}	-65 ... 150	
Storage temperature	T_{stg}	-65 ... 150	

Thermal Resistance

Parameter	Symbol	Value	Unit
Junction - soldering point ²⁾	R_{thJS}	≤ 150	K/W

Electrical Characteristics at $T_{\text{A}} = 25^\circ\text{C}$, unless otherwise specified

Parameter	Symbol	Values			Unit
		min.	typ.	max.	

DC Characteristics

Collector-emitter breakdown voltage $I_{\text{C}} = 3 \text{ mA}$, $I_{\text{B}} = 0$	$V_{(\text{BR})\text{CEO}}$	4	4.7	-	V
Collector-emitter cutoff current $V_{\text{CE}} = 13 \text{ V}$, $V_{\text{BE}} = 0$	I_{CES}	-	-	100	μA
Collector-base cutoff current $V_{\text{CB}} = 5 \text{ V}$, $I_{\text{E}} = 0$	I_{CBO}	-	-	100	nA
Emitter-base cutoff current $V_{\text{EB}} = 0.5 \text{ V}$, $I_{\text{C}} = 0$	I_{EBO}	-	-	10	μA
DC current gain $I_{\text{C}} = 60 \text{ mA}$, $V_{\text{CE}} = 3 \text{ V}$, pulse measured	h_{FE}	160	250	400	-

¹ T_{S} is measured on the collector lead at the soldering point to the pcb

² For calculation of R_{thJA} please refer to Application Note Thermal Resistance

 R_{thJS} demanded by P_{tot} and T_{S} , to be fulfilled by design

Electrical Characteristics at $T_A = 25^\circ\text{C}$, unless otherwise specified

Parameter	Symbol	Values			Unit
		min.	typ.	max.	
AC Characteristics (verified by random sampling)					
Transition frequency $I_C = 60\text{ mA}$, $V_{CE} = 3\text{ V}$, $f = 2\text{ GHz}$	f_T	-	37	-	GHz
Collector-base capacitance $V_{CB} = 3\text{ V}$, $f = 1\text{ MHz}$, emitter grounded	C_{cb}	-	0.24	0.42	pF
Collector emitter capacitance $V_{CE} = 3\text{ V}$, $f = 1\text{ MHz}$, base grounded	C_{ce}	-	0.31	-	
Emitter-base capacitance $V_{EB} = 0.5\text{ V}$, $f = 1\text{ MHz}$, collector grounded	C_{eb}	-	0.97	-	
Noise figure $I_C = 25\text{ mA}$, $V_{CE} = 3\text{ V}$, $f = 1.8\text{ GHz}$, $Z_S = Z_{Sopt}$ $I_C = 25\text{ mA}$, $V_{CE} = 3\text{ V}$, $f = 6\text{ GHz}$, $Z_S = Z_{Sopt}$	F	-	0.6 1.1	-	dB
Power gain, maximum stable ¹⁾ $I_C = 60\text{ mA}$, $V_{CE} = 3\text{ V}$, $Z_S = Z_{Sopt}$, $Z_L = Z_{Lopt}$, $f = 1.8\text{ GHz}$	G_{ms}	-	21	-	dB
Power gain, maximum available ¹⁾ $I_C = 60\text{ mA}$, $V_{CE} = 3\text{ V}$, $Z_S = Z_{Sopt}$, $Z_L = Z_{Lopt}$, $f = 6\text{ GHz}$	G_{ma}	-	11.5	-	dB
Transducer gain $I_C = 60\text{ mA}$, $V_{CE} = 3\text{ V}$, $Z_S = Z_L = 50\ \Omega$, $f = 1.8\text{ GHz}$ $I_C = 60\text{ mA}$, $V_{CE} = 3\text{ V}$, $Z_S = Z_L = 50\ \Omega$, $f = 6\text{ GHz}$	$ S_{21e} ^2$	-	18 8	-	dB
Third order intercept point at output ²⁾ $V_{CE} = 3\text{ V}$, $I_C = 60\text{ mA}$, $f = 1.8\text{ GHz}$, $Z_S = Z_L = 50\ \Omega$	IP_3	-	29.5	-	dBm
1dB Compression point at output $I_C = 60\text{ mA}$, $V_{CE} = 3\text{ V}$, $Z_S = Z_L = 50\ \Omega$, $f = 1.8\text{ GHz}$	P_{-1dB}	-	16.5	-	

¹⁾ $G_{ma} = |S_{21e} / S_{12e}| (k - (k^2 - 1)^{1/2})$, $G_{ms} = |S_{21e} / S_{12e}|$
²⁾ IP_3 value depends on termination of all intermodulation frequency components.
Termination used for this measurement is $50\ \Omega$ from 0.1 MHz to 6 GHz

SPICE Parameter (Gummel-Poon Model, Berkley-SPICE 2G.6 Syntax):
Transistor Chip Data:

IS =	2.66 e-12	mA	BF =	753	-	NF =	1.015	-
VAF =	95	V	IKF =	292	mA	ISE =	1.54 e-11	mA
NE =	1.8	-	BR =	76	-	NR =	1	-
VAR =	1.33	V	IKR =	1.33	mA	ISC =	1 e-27	mA
NC =	2	-	RB =	1	Ω	IRB =	1 e15	A
RBM =	0.9	Ω	RE =	20	m Ω	RC =	0.9	Ω
CJE =	0.475	pF	VJE =	0.69	V	MJE =	0.085	-
TF =	0.0021	ns	XTF =	3	-	VTF =	2.1	V
ITF =	2540	mA	PTF =	0.5	-	CJC =	0.173	pF
VJC =	0.45	V	MJC =	0.31	-	XCJC =	0.01	-
TR =	1.2	ns	CJS =	0.325	pF	VJS =	0.65	V
MJS =	0.25	-	XTB =	-2.2	-	EG =	1.11	-
XTI =	0.436	-	FC =	0.5	-	TNOM	25	$^{\circ}\text{C}$
AF =	1	-	KF =	0	-			

All parameters are ready to use, no scaling is necessary.

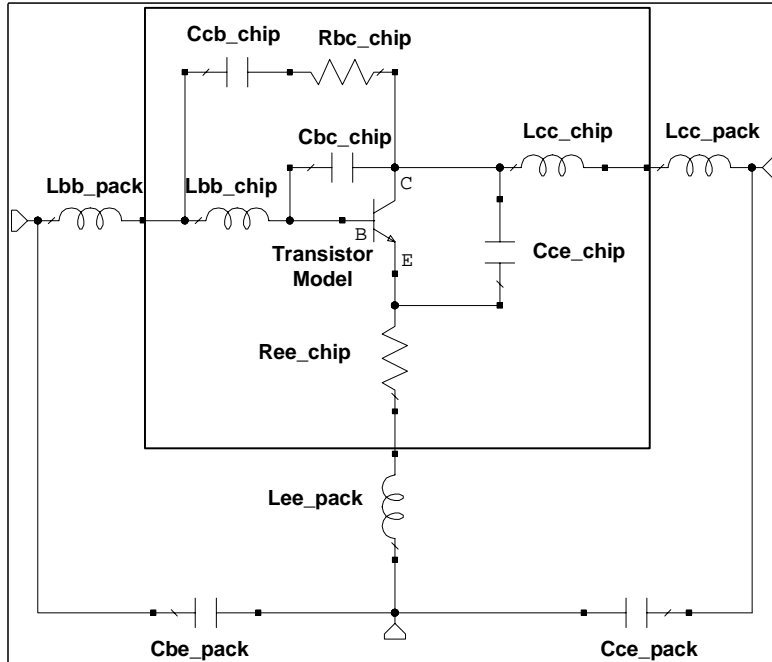
Package Equivalent Circuit:

L_{bb_chip}	=	0.212	nA
L_{cc_chip}	=	0.07472	nH
L_{bb_pack}	=	0.0184	nH
L_{cc_pack}	=	0.277	nH
L_{ee_pack}	=	0.239	nH
C_{bc_chip}	=	0.015	pF
C_{cb_chip}	=	0.013	pF
C_{ce_chip}	=	0.282	pF
C_{be_pack}	=	0.064	pF
C_{ce_pack}	=	0.0492	pF
R_{bc_chip}	=	7	Ω
R_{ee_chip}	=	0.566	Ω

Valid up to 6GHz

For examples and ready to use parameters please contact your local Infineon Technologies distributor or sales office to obtain a Infineon Technologies CD-ROM or see Internet: <http://www.infineon.com>

Total power dissipation $P_{tot} = f(T_S)$

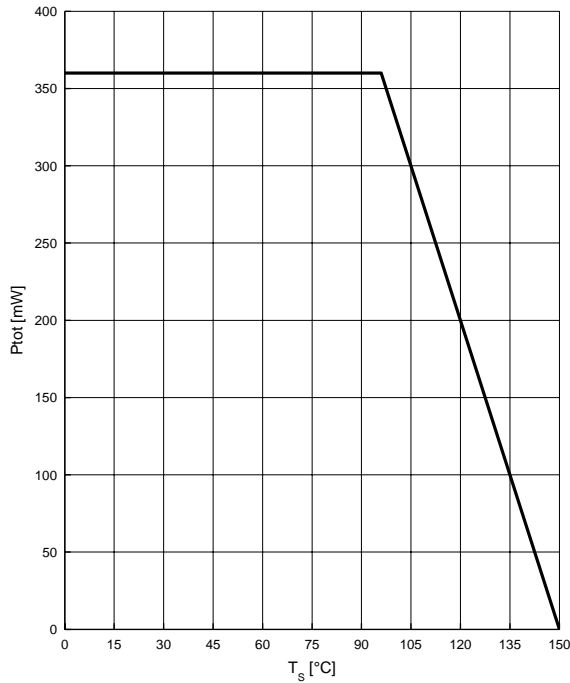

Permissible Puls Load $R_{thJS} = f(t_p)$

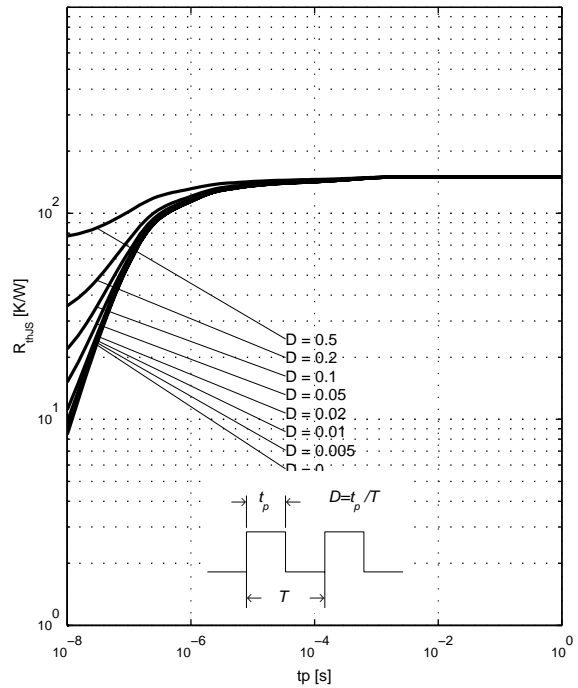

Permissible Pulse Load

$P_{totmax}/P_{totDC} = f(t_p)$

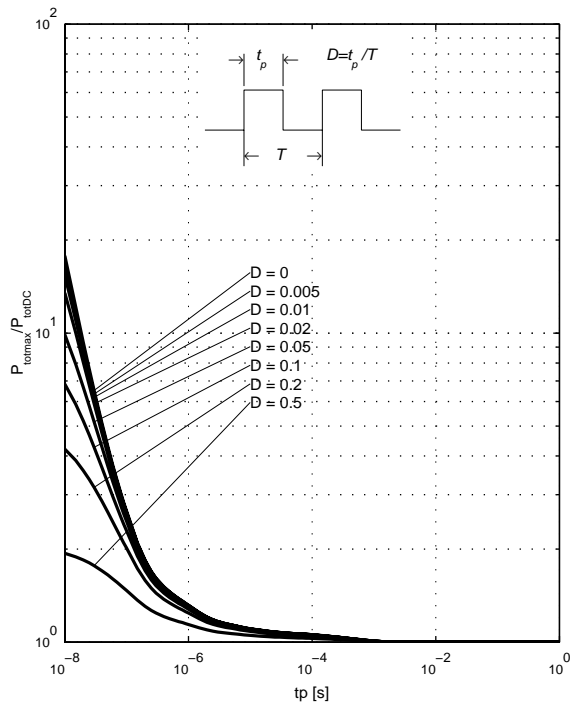

Collector-base capacitance $C_{cb} = f(V_{CB})$

$f = 1$ MHz

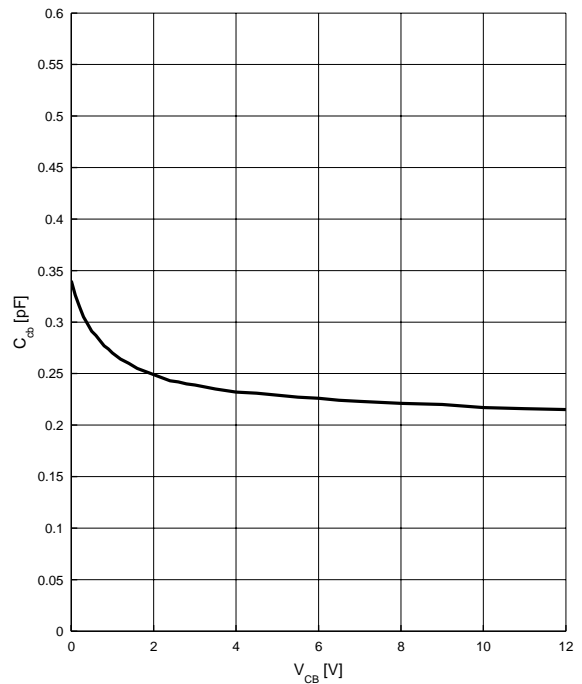

Transition frequency $f_T = f(I_C)$

$V_{CE} = \text{parameter}, f = 1 \text{ GHz}$

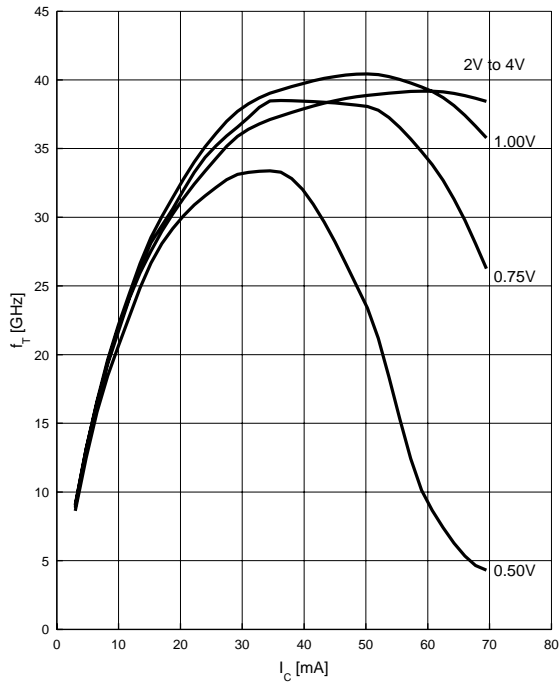

Power gain $G_{ma}, G_{ms} = f(f)$

$V_{CE} = 3 \text{ V}, I_C = 60 \text{ mA}$

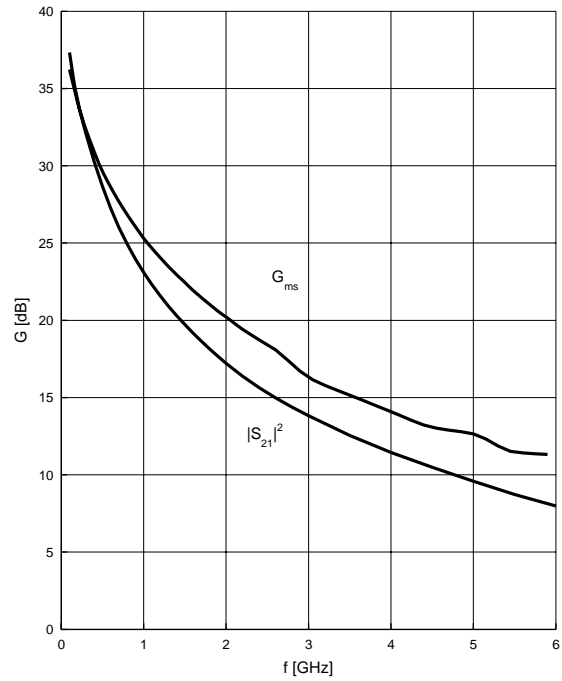

Power gain $G_{ma}, G_{ms} = f(I_C)$

$V_{CE} = 3 \text{ V}$

$f = \text{parameter}$

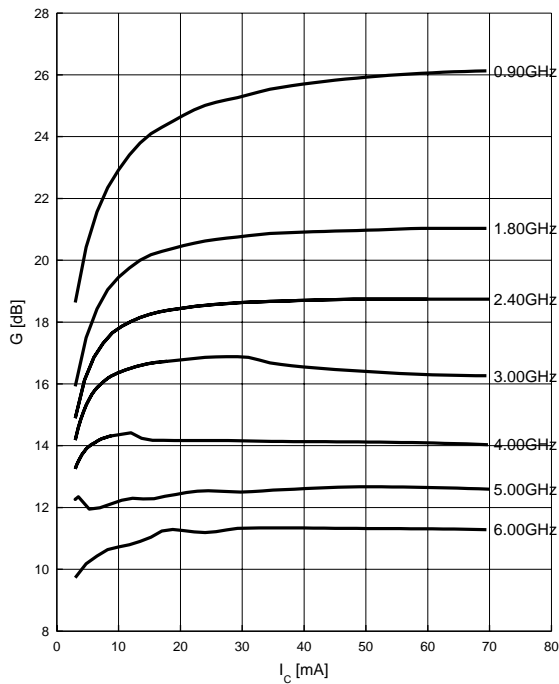

Power gain $G_{ma}, G_{ms} = f(V_{CE})$

$I_C = 60 \text{ mA}$

$f = \text{parameter}$

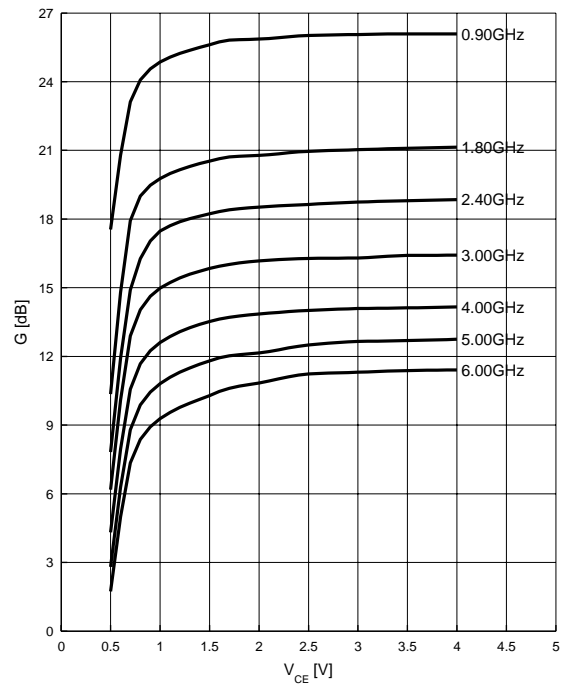

Package Outline

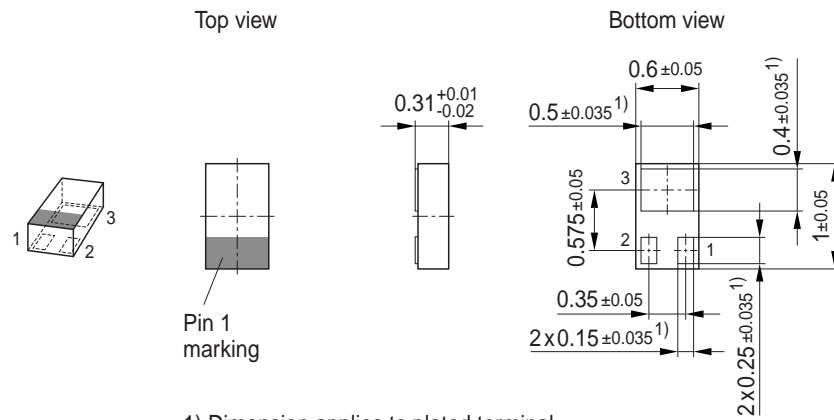

1) Dimension applies to plated terminal

Foot Print

For board assembly information please refer to Infineon website "Packages"

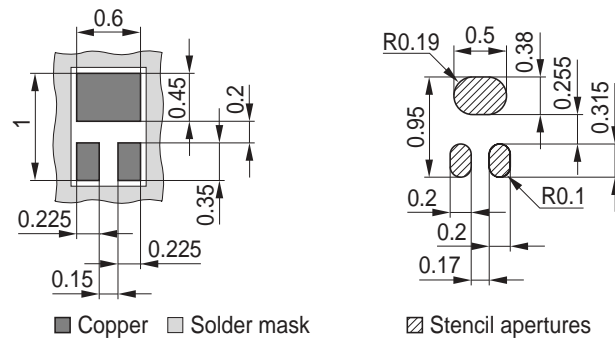

Marking Layout (Example)

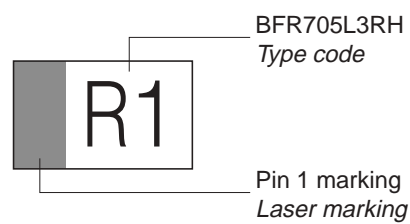

Standard Packing

Reel ø180 mm = 15.000 Pieces/Reel

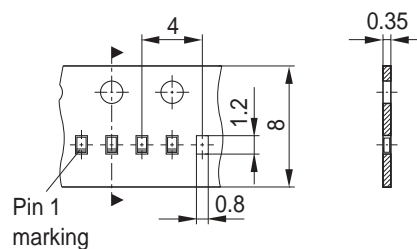

Edition 2006-02-01

Published by

Infineon Technologies AG

81726 München, Germany

© Infineon Technologies AG 2007.

All Rights Reserved.

Attention please!

The information given in this dokument shall in no event be regarded as a guarantee of conditions or characteristics ("Beschaffenheitsgarantie"). With respect to any examples or hints given herein, any typical values stated herein and/or any information regarding the application of the device, Infineon Technologies hereby disclaims any and all warranties and liabilities of any kind, including without limitation warranties of non-infringement of intellectual property rights of any third party.

Information

For further information on technology, delivery terms and conditions and prices please contact your nearest Infineon Technologies Office (www.infineon.com).

Warnings

Due to technical requirements components may contain dangerous substances. For information on the types in question please contact your nearest Infineon Technologies Office.

Infineon Technologies Components may only be used in life-support devices or systems with the express written approval of Infineon Technologies, if a failure of such components can reasonably be expected to cause the failure of that life-support device or system, or to affect the safety or effectiveness of that device or system.

Life support devices or systems are intended to be implanted in the human body, or to support and/or maintain and sustain and/or protect human life. If they fail, it is reasonable to assume that the health of the user or other persons may be endangered.

Looking for pricing, stock, or lifecycle information?

Click below to explore more details on WIN SOURCE:

- ⊖ [View BFR750L3RHE6327XTSA1 on WIN SOURCE](#)
- ⊖ [Infineon Technologies Information](#)

Optimize Your Supply Chain with WIN SOURCE Solutions

- ✓ Global Sourcing Solution
- ✓ Obsolete Management
- ✓ Cost Control Management
- ✓ Shortage Management
- ✓ Alternative Solution
- ✓ Excess Inventory Management