

BFR93AR

NPN 6 GHz wideband transistor

Rev. 01 — 30 November 2006

Product data sheet

1. Product profile

1.1 General description

NPN wideband transistor in a plastic SOT23 package.
PNP complement: BFT93.

1.2 Features

- Very high power gain
- Low noise figure
- Very low intermodulation distortion

1.3 Applications

- RF wideband amplifiers and oscillators

1.4 Quick reference data

Table 1. Quick reference data

Symbol	Parameter	Conditions	Min	Typ	Max	Unit
V_{CBO}	collector-base voltage	open emitter	-	-	15	V
V_{CEO}	collector-emitter voltage	open base	-	-	12	V
I_C	collector current		-	-	35	mA
P_{tot}	total power dissipation	$T_{sp} \leq 95\text{ °C}$	-	-	300	mW
C_{re}	feedback capacitance	$I_C = 0\text{ mA}; V_{CE} = 5\text{ V}; f = 1\text{ MHz};$	-	0.6	-	pF
f_T	transition frequency	$I_C = 30\text{ mA}; V_{CE} = 5\text{ V};$ $f = 500\text{ MHz};$	-	6	-	GHz
G_{UM}	unilateral power gain	$I_C = 30\text{ mA}; V_{CE} = 8\text{ V};$ $T_{amb} = 25\text{ °C}$				
		$f = 1\text{ GHz}$	-	13	-	dB
		$f = 2\text{ GHz}$	-	7	-	dB
NF	noise figure	$I_C = 5\text{ mA}; V_{CE} = 8\text{ V}; f = 1\text{ GHz};$ $\Gamma_S = \Gamma_{opt}; T_{amb} = 25\text{ °C}$	-	1.9	-	dB
V_O	output voltage	IMD = -60 dB; $I_C = 30\text{ mA};$ $V_{CE} = 8\text{ V}; R_L = 75\text{ }\Omega;$ $T_{amb} = 25\text{ °C};$ $f_p + f_q - f_r = 793.25\text{ MHz}$	-	425	-	mV

2. Pinning information

Table 2. Pinning

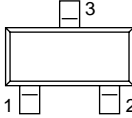
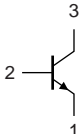
Pin	Description	Simplified outline	Symbol
1	emitter		
2	base		
3	collector		

sym026

3. Ordering information

Table 3. Ordering information

Type number	Package		
	Name	Description	Version
BFR93AR	-	plastic surface-mounted package; 3 leads	SOT23

4. Marking

Table 4. Marking

Type number	Marking code	Description
BFR93AR	*R5	* = p : made in Hong Kong * = w : made in China

5. Limiting values

Table 5. Limiting values

In accordance with the Absolute Maximum Rating System (IEC 60134).

Symbol	Parameter	Conditions	Min	Max	Unit
V_{CBO}	collector-base voltage	open emitter	-	15	V
V_{CEO}	collector-emitter voltage	open base	-	12	V
V_{EBO}	emitter-base voltage	open collector	-	2	V
I_C	collector current		-	35	mA
P_{tot}	total power dissipation	$T_{sp} \leq 95\text{ °C}$; see Figure 2	[1]	300	mW
T_{stg}	storage temperature		-65	+150	°C
T_j	junction temperature		-	+175	°C

[1] T_{sp} is the temperature at the solder point of the collector pin.

6. Thermal characteristics

Table 6. Thermal characteristics

Symbol	Parameter	Conditions	Typ	Unit
$R_{th(j-sp)}$	thermal resistance from junction to solder point	$T_{sp} \leq 95\text{ °C}$	[1] 260	K/W

[1] T_{sp} is the temperature at the solder point of the collector pin.

7. Characteristics

Table 7. Characteristics

Symbol	Parameter	Conditions	Min	Typ	Max	Unit
I_{CBO}	collector-base cut-off current	$I_E = 0\text{ A}; V_{CB} = 5\text{ V}$	-	-	50	nA
h_{FE}	DC current gain	$I_C = 30\text{ mA}; V_{CE} = 5\text{ V};$ see Figure 3	40	90	-	
C_c	collector capacitance	$I_E = i_e = 0\text{ A}; V_{CB} = 5\text{ V}; f = 1\text{ MHz};$ see Figure 4	-	0.7	-	pF
C_e	emitter capacitance	$I_C = i_c = 0\text{ A}; V_{EB} = 0.5\text{ V}; f = 1\text{ MHz}$	-	1.9	-	pF
C_{re}	feedback capacitance	$I_C = i_c = 0\text{ A}; V_{CE} = 5\text{ V}; f = 1\text{ MHz};$ $T_{amb} = 25\text{ °C}$	-	0.6	-	pF
f_T	transition frequency	$I_C = 30\text{ mA}; V_{CE} = 5\text{ V}; f = 500\text{ MHz};$ see Figure 5	4.5	6	-	GHz
G_{UM}	unilateral power gain	$I_C = 30\text{ mA}; V_{CE} = 8\text{ V}; T_{amb} = 25\text{ °C};$ see Figure 6 to Figure 9	[1]			
		$f = 1\text{ GHz}$	-	13	-	dB
		$f = 2\text{ GHz}$	-	7	-	dB
NF	noise figure	$I_C = 5\text{ mA}; V_{CE} = 8\text{ V}; \Gamma_S = \Gamma_{opt};$ $T_{amb} = 25\text{ °C};$ see Figure 12 and Figure 13				
		$f = 1\text{ GHz}$	-	1.9	-	dB
		$f = 2\text{ GHz}$	-	3	-	dB
V_O	output voltage		[2][3]	-	425	mV
IMD2	second-order intermodulation distortion	see Figure 15	[2][4]	-	-50	dB

[1] G_{UM} is the maximum unilateral power gain, assuming S_{12} is zero and

$$G_{UM} = 10 \log \frac{|S_{21}|^2}{(1 - |S_{11}|^2)(1 - |S_{22}|^2)} \text{ dB.}$$

[2] Measured on the same crystal in a SOT37 package (BFR91A).

[3] $IMD = -60\text{ dB}$ (DIN 45004B); $I_C = 30\text{ mA}; V_{CE} = 8\text{ V}; R_L = 75\text{ }\Omega; T_{amb} = 25\text{ °C};$

$V_p = V_O$ at $IMD = -60\text{ dB}; f_p = 795.25\text{ MHz};$

$V_q = V_O - 6\text{ dB}$ at $f_q = 803.25\text{ MHz};$

$V_r = V_O - 6\text{ dB}$ at $f_r = 805.25\text{ MHz};$

measured at $f_p + f_q - f_r = 793.25\text{ MHz}$

[4] $I_C = 30\text{ mA}; V_{CE} = 8\text{ V}; R_L = 75\text{ }\Omega; T_{amb} = 25\text{ °C};$

$V_p = 200\text{ mV}$ at $f_p = 250\text{ MHz};$

$V_q = 200\text{ mV}$ at $f_p = 560\text{ MHz};$

measured at $f_p + f_q = 810\text{ MHz}$

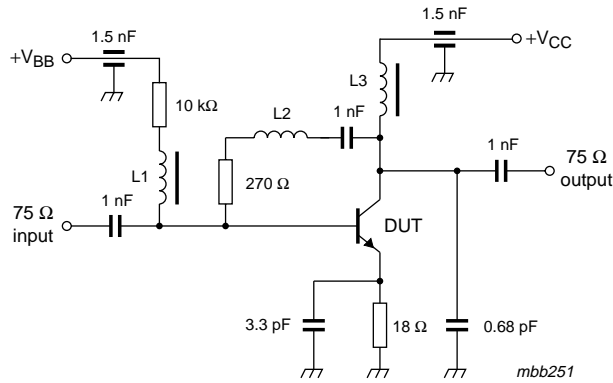

L1 = L3 = 5 μH choke.
 L2 = 3 turns 0.4 mm copper wire; winding pitch 1 mm; internal diameter 3 mm.

Fig 1. Intermodulation distortion and second harmonic MATV test circuit

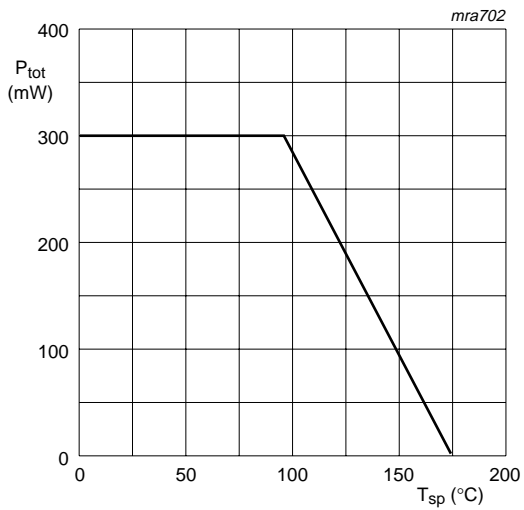
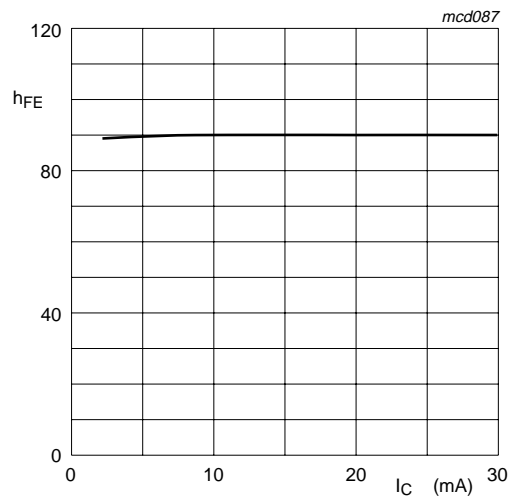
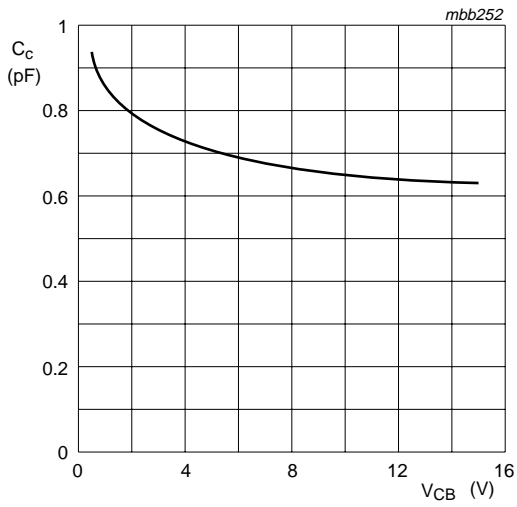

Fig 2. Power derating curve



V_{CE} = 5 V; T_j = 25 °C.

Fig 3. DC current gain as a function of collector current



$I_E = I_E = 0 \text{ mA}$; $f = 1 \text{ MHz}$; $T_j = 25 \text{ }^\circ\text{C}$.

Fig. 4. Collector capacitance as a function of collector-base voltage; typical values

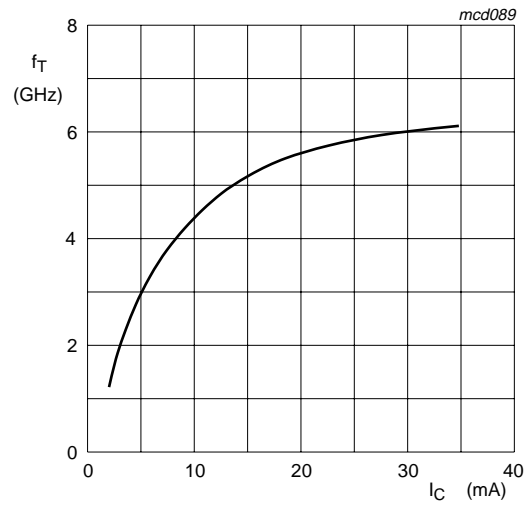

$V_{CE} = 2 \text{ V}$; $f = 500 \text{ MHz}$; $T_j = 25 \text{ }^\circ\text{C}$.

Fig. 5. Transition frequency as a function of collector current; typical values

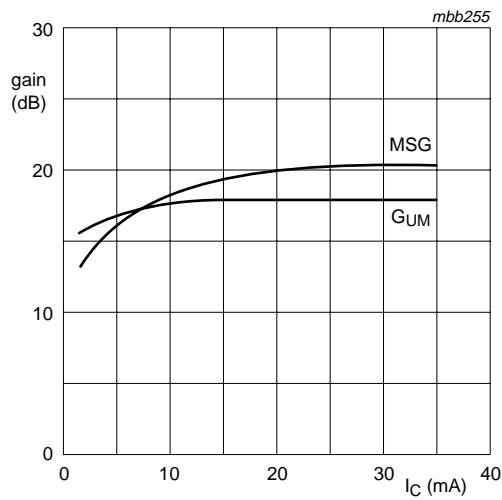

$V_{CE} = 8 \text{ V}$; $f = 500 \text{ MHz}$.

Fig. 6. Gain as a function of collector current; typical values

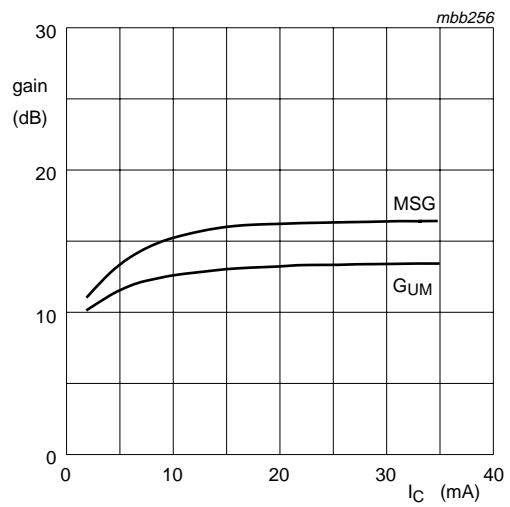

$V_{CE} = 8 \text{ V}$; $f = 1 \text{ GHz}$.

Fig. 7. Gain as a function of collector current; typical values

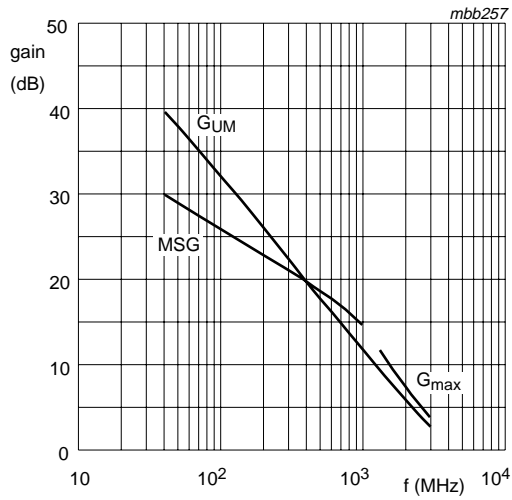

$I_C = 10 \text{ mA}; V_{CE} = 8 \text{ V}.$

Fig 8. Gain as a function of frequency; typical values

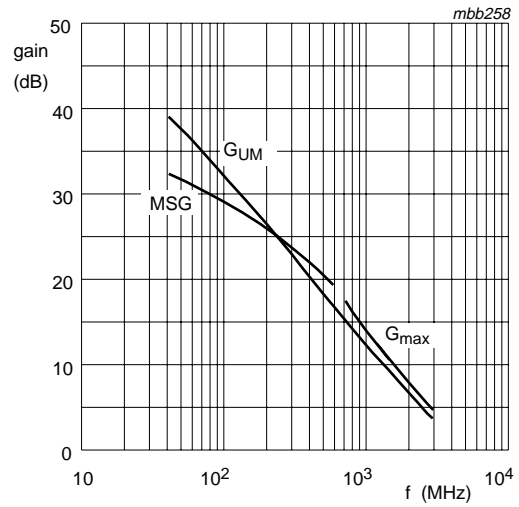

$I_C = 30 \text{ mA}; V_{CE} = 8 \text{ V}.$

Fig 9. Gain as a function of frequency; typical values

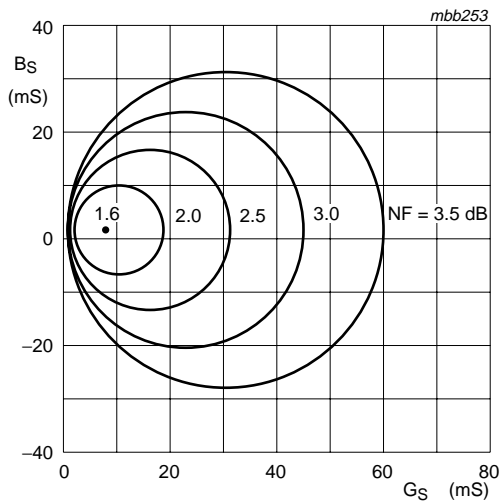

$I_C = 4 \text{ mA}; V_{CE} = 8 \text{ V}; f = 800 \text{ MHz}; T_{amb} = 25 \text{ }^\circ\text{C}.$

Fig 10. Circles of constant noise figure; typical values

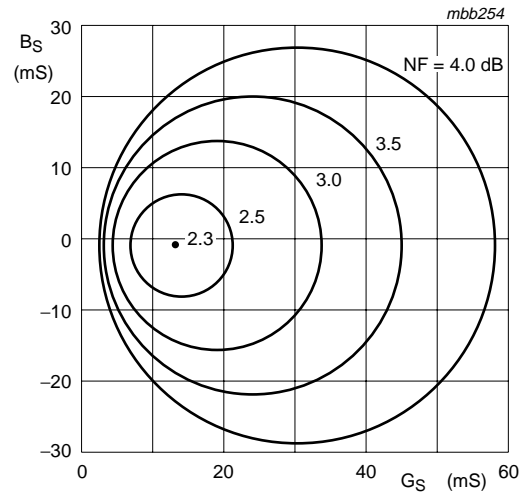

$I_C = 4 \text{ mA}; V_{CE} = 8 \text{ V}; f = 800 \text{ MHz}; T_{amb} = 25 \text{ }^\circ\text{C}.$

Fig 11. Circles of constant noise figure; typical values

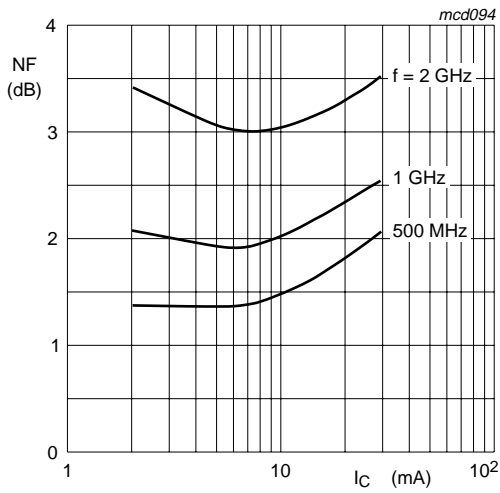

$V_{CE} = 8\text{ V}$.

Fig 12. Minimum noise figure as a function of collector current; typical values

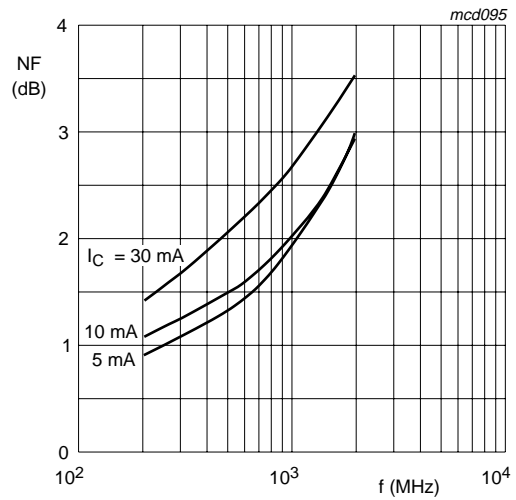

$V_{CE} = 8\text{ V}$.

Fig 13. Minimum noise figure as a function of frequency; typical values

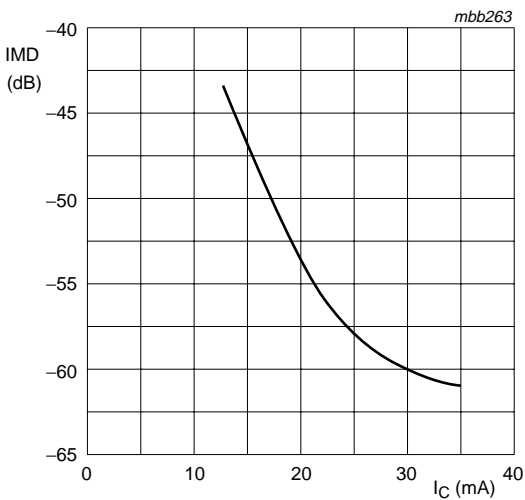

$V_{CE} = 8\text{ V}$; $V_O = 425\text{ mV}$ (52.6 dBmV);
 $f_p + f_q - f_r = 793.25\text{ MHz}$; $T_{amb} = 25\text{ }^\circ\text{C}$.
 Measured in MATV test circuit; see [Figure 1](#).

Fig 14. Intermodulation distortion; typical values

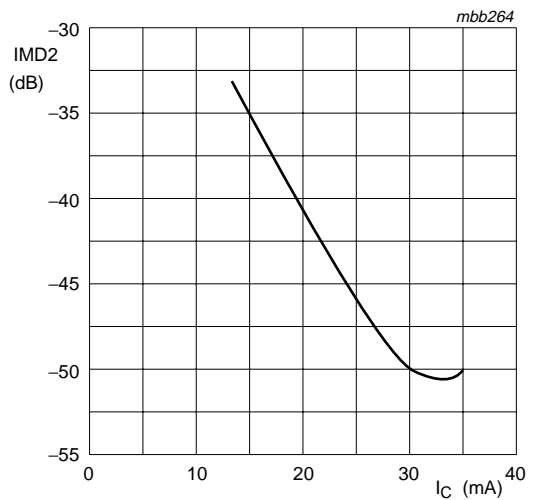

$V_{CE} = 8\text{ V}$; $V_O = 200\text{ mV}$ (46 dBmV);
 $f_p + f_q - f_r = 810\text{ MHz}$; $T_{amb} = 25\text{ }^\circ\text{C}$.
 Measured in MATV test circuit; see [Figure 1](#).

Fig 15. Second order intermodulation distortion; typical values

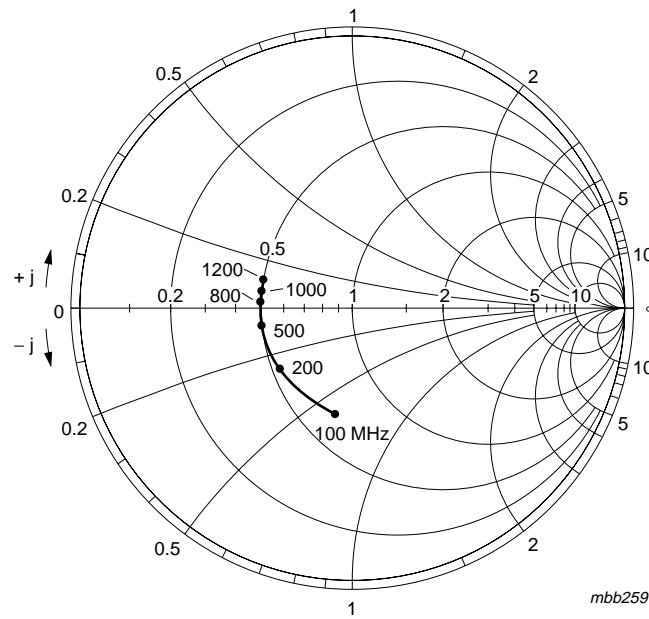

$I_C = 30 \text{ mA}; V_{CE} = 8 \text{ V}; Z_O = 50 \Omega; T_{amb} = 25 \text{ }^\circ\text{C}.$

Fig 16. Common emitter input reflection coefficient (S_{11})

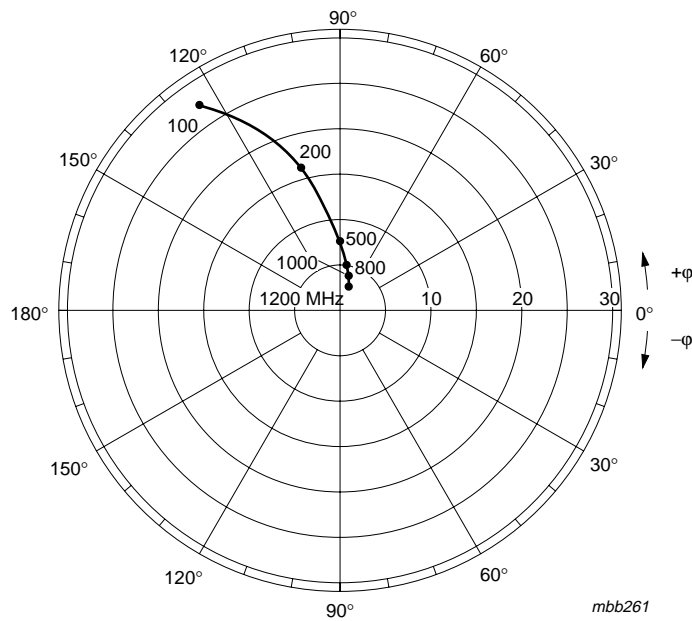

$I_C = 30 \text{ mA}; V_{CE} = 8 \text{ V}; T_{amb} = 25 \text{ }^\circ\text{C}.$

Fig 17. Common emitter forward transmission coefficient (S_{21})

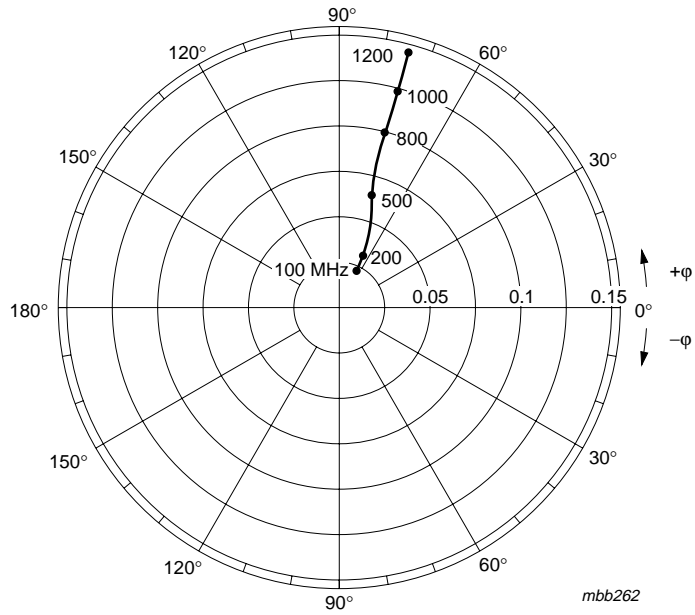

$I_C = 30 \text{ mA}$; $V_{CE} = 8 \text{ V}$; $T_{amb} = 25 \text{ }^\circ\text{C}$.

Fig 18. Common emitter reverse transmission coefficient (S_{12})

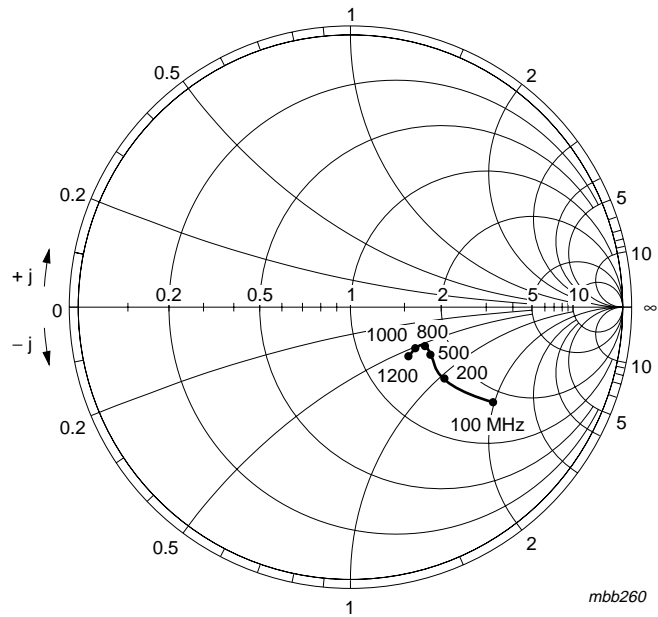

$I_C = 30 \text{ mA}$; $V_{CE} = 8 \text{ V}$; $Z_O = 50 \text{ } \Omega$; $T_{amb} = 25 \text{ }^\circ\text{C}$.

Fig 19. Common emitter output reflection coefficient (S_{22})

8. Package outline

Plastic surface-mounted package; 3 leads

SOT23

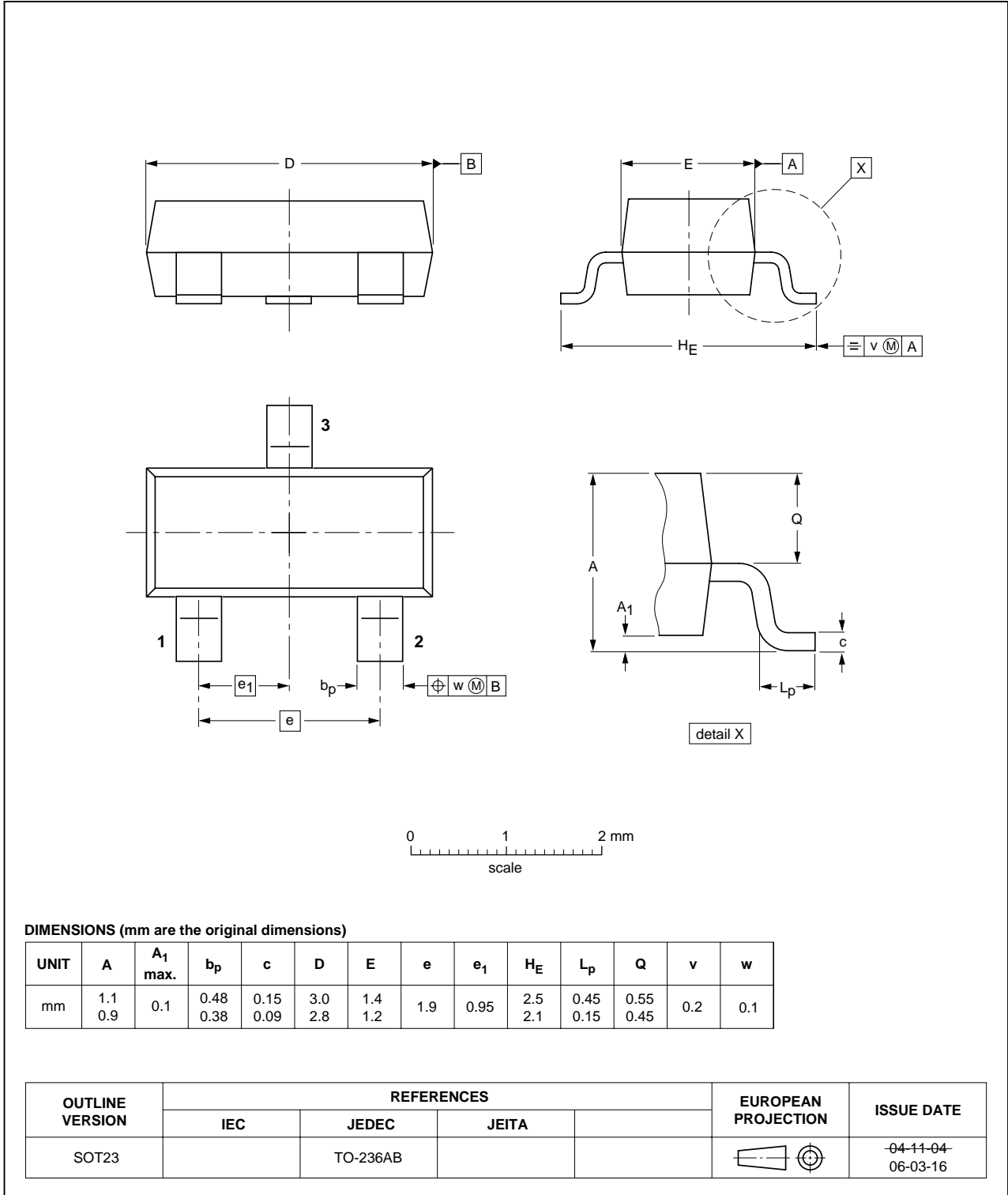

Fig 20. Package outline SOT23

9. Abbreviations

Table 8. Abbreviations

Acronym	Description
NPN	Negative Positive Negative
PNP	Positive Negative Positive
RF	Radio Frequency
MATV	Master Antenna Television

10. Revision history

Table 9. Revision history

Document ID	Release date	Data sheet status	Change notice	Supersedes
BFR93AR_1	20061130	Product data sheet	-	-

11. Legal information

11.1 Data sheet status

Document status ^{[1][2]}	Product status ^[3]	Definition
Objective [short] data sheet	Development	This document contains data from the objective specification for product development.
Preliminary [short] data sheet	Qualification	This document contains data from the preliminary specification.
Product [short] data sheet	Production	This document contains the product specification.

[1] Please consult the most recently issued document before initiating or completing a design.

[2] The term 'short data sheet' is explained in section "Definitions".

[3] The product status of device(s) described in this document may have changed since this document was published and may differ in case of multiple devices. The latest product status information is available on the Internet at URL <http://www.nxp.com>.

11.2 Definitions

Draft — The document is a draft version only. The content is still under internal review and subject to formal approval, which may result in modifications or additions. NXP Semiconductors does not give any representations or warranties as to the accuracy or completeness of information included herein and shall have no liability for the consequences of use of such information.

Short data sheet — A short data sheet is an extract from a full data sheet with the same product type number(s) and title. A short data sheet is intended for quick reference only and should not be relied upon to contain detailed and full information. For detailed and full information see the relevant full data sheet, which is available on request via the local NXP Semiconductors sales office. In case of any inconsistency or conflict with the short data sheet, the full data sheet shall prevail.

11.3 Disclaimers

General — Information in this document is believed to be accurate and reliable. However, NXP Semiconductors does not give any representations or warranties, expressed or implied, as to the accuracy or completeness of such information and shall have no liability for the consequences of use of such information.

Right to make changes — NXP Semiconductors reserves the right to make changes to information published in this document, including without limitation specifications and product descriptions, at any time and without notice. This document supersedes and replaces all information supplied prior to the publication hereof.

Suitability for use — NXP Semiconductors products are not designed, authorized or warranted to be suitable for use in medical, military, aircraft, space or life support equipment, nor in applications where failure or

malfunction of a NXP Semiconductors product can reasonably be expected to result in personal injury, death or severe property or environmental damage. NXP Semiconductors accepts no liability for inclusion and/or use of NXP Semiconductors products in such equipment or applications and therefore such inclusion and/or use is at the customer's own risk.

Applications — Applications that are described herein for any of these products are for illustrative purposes only. NXP Semiconductors makes no representation or warranty that such applications will be suitable for the specified use without further testing or modification.

Limiting values — Stress above one or more limiting values (as defined in the Absolute Maximum Ratings System of IEC 60134) may cause permanent damage to the device. Limiting values are stress ratings only and operation of the device at these or any other conditions above those given in the Characteristics sections of this document is not implied. Exposure to limiting values for extended periods may affect device reliability.

Terms and conditions of sale — NXP Semiconductors products are sold subject to the general terms and conditions of commercial sale, as published at <http://www.nxp.com/profile/terms>, including those pertaining to warranty, intellectual property rights infringement and limitation of liability, unless explicitly otherwise agreed to in writing by NXP Semiconductors. In case of any inconsistency or conflict between information in this document and such terms and conditions, the latter will prevail.

No offer to sell or license — Nothing in this document may be interpreted or construed as an offer to sell products that is open for acceptance or the grant, conveyance or implication of any license under any copyrights, patents or other industrial or intellectual property rights.

11.4 Trademarks

Notice: All referenced brands, product names, service names and trademarks are the property of their respective owners.

12. Contact information

For additional information, please visit: <http://www.nxp.com>

For sales office addresses, send an email to: salesaddresses@nxp.com

13. Contents

1	Product profile	1
1.1	General description	1
1.2	Features	1
1.3	Applications	1
1.4	Quick reference data	1
2	Pinning information	2
3	Ordering information	2
4	Marking	2
5	Limiting values	2
6	Thermal characteristics	3
7	Characteristics	3
8	Package outline	10
9	Abbreviations	11
10	Revision history	11
11	Legal information	12
11.1	Data sheet status	12
11.2	Definitions	12
11.3	Disclaimers	12
11.4	Trademarks	12
12	Contact information	12
13	Contents	13

Please be aware that important notices concerning this document and the product(s) described herein, have been included in section 'Legal information'.



© NXP B.V. 2006.

All rights reserved.

For more information, please visit: <http://www.nxp.com>



For sales office addresses, please send an email to: salesaddresses@nxp.com

Date of release: 30 November 2006

Document identifier: BFR93AR_1

Looking for pricing, stock, or lifecycle information?

Click below to explore more details on WIN SOURCE:

-  [View BFR93AR,215 on WIN SOURCE](#)
-  [NXP / Nexperia Information](#)

Optimize Your Supply Chain with WIN SOURCE Solutions

-  Global Sourcing Solution
-  Obsolete Management
-  Cost Control Management
-  Shortage Management
-  Alternative Solution
-  Excess Inventory Management