



**THE DATASHEET OF
BGB540E6327**



Data sheet, BGB540, Sept. 2002

BGB540

Active Biased RF Transistor

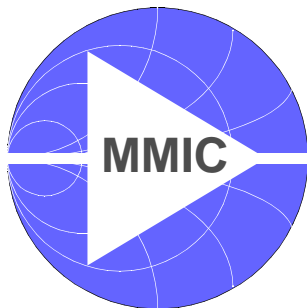

Wireless
Silicon Discretes



Never stop thinking.

Edition 2002-09-11

**Published by Infineon Technologies AG,
St.-Martin-Strasse 53,
D-81541 München**

**© Infineon Technologies AG 2002.
All Rights Reserved.**

Attention please!

The information herein is given to describe certain components and shall not be considered as warranted characteristics.

Terms of delivery and rights to technical change reserved.

We hereby disclaim any and all warranties, including but not limited to warranties of non-infringement, regarding circuits, descriptions and charts stated herein.

Infineon Technologies is an approved CECC manufacturer.

Information

For further information on technology, delivery terms and conditions and prices please contact your nearest Infineon Technologies Office in Germany or our Infineon Technologies Representatives worldwide (see address list).

Warnings

Due to technical requirements components may contain dangerous substances. For information on the types in question please contact your nearest Infineon Technologies Office.

Infineon Technologies Components may only be used in life-support devices or systems with the express written approval of Infineon Technologies, if a failure of such components can reasonably be expected to cause the failure of that life-support device or system, or to affect the safety or effectiveness of that device or system. Life support devices or systems are intended to be implanted in the human body, or to support and/or maintain and sustain and/or protect human life. If they fail, it is reasonable to assume that the health of the user or other persons may be endangered.

BGB540**Data sheet****Revision History: 2002-09-11**

Previous Version: 2001-08-16

Page	Subjects (major changes since last revision)
4-9	RF parameters and SPICE model updated
	Preliminary status removed

For questions on technology, delivery and prices please contact the Infineon Technologies Offices in Germany or the Infineon Technologies Companies and Representatives worldwide: see our webpage at <http://www.infineon.com>



Active Biased RF Transistor

BGB540

Features

- $G_{ms} = 18\text{dB}$ at 1.8GHz
- Small SOT343 package
- Current easy adjustable by an external resistor
- Open collector output
- Typical supply voltage: 1.4-4.3V
- SIEGET[®]-45 technology

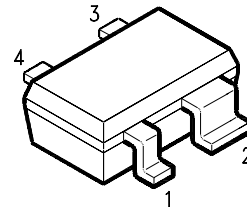

Applications

- For high gain low noise amplifiers
- Ideal for wideband applications, cellular phones, cordless telephones, SAT-TV and high frequency oscillators

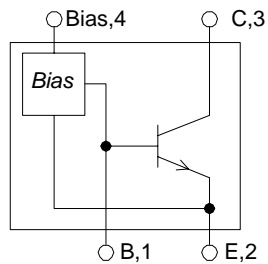

Description

SIEGET[®]-45 NPN Transistor with integrated biasing for high gain low noise figure applications. I_C can be controlled using I_{Bias} according to $I_C = 10 * I_{Bias}$.

ESD: Electrostatic discharge sensitive device, observe handling precaution!

Type	Package	Marking	Chip
BGB540	SOT343	MCs	T0559

Maximum Ratings

Parameter	Symbol	Value	Unit
Maximum collector-emitter voltage	V_{CE}	4.5	V
Maximum collector current	I_C	80	mA
Maximum bias current	I_{Bias}	8	mA
Maximum emitter-base voltage	V_{EB}	1.2	V
Maximum base current	I_B	0.7	mA
Total power dissipation, $T_S < 75^\circ\text{C}^{1)}$	P_{tot}	250	mW
Junction temperature	T_J	150	$^\circ\text{C}$
Ambient temperature	T_A	-65 ... +150	$^\circ\text{C}$
Storage temperature	T_{STG}	-65 ... +150	$^\circ\text{C}$
Thermal resistance: junction-soldering point	$R_{th JS}$	300	K/W

Notes:

For detailed symbol description refer to figure 1.

¹⁾ T_S is measured on the emitter lead at the soldering point to the PCB

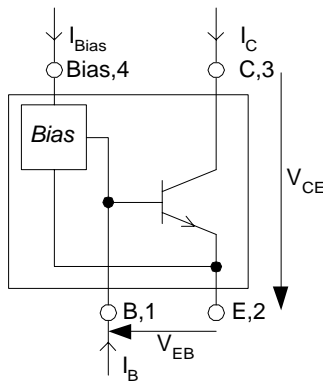

Fig. 1: Symbol definition

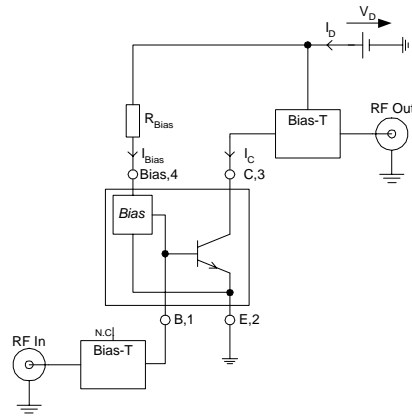

Fig. 2: Test Circuit for Electrical Characteristics and S-Parameter

Electrical Characteristics at $T_A=25^\circ\text{C}$ (measured in test circuit specified in fig. 2)

Parameter	Symbol	min.	typ.	max.	Unit
Maximum stable power gain $V_D=2\text{V}$, $I_C=20\text{mA}$, $f=1.8\text{GHz}$	G_{ms}		18		dB
Insertion power gain $V_D=2\text{V}$, $I_C=20\text{mA}$	$ S_{21} ^2$		21.5 16		dB
Insertion loss $V_D=2\text{V}$, $I_C=0\text{mA}$	IL		21 16		dB
Noise figure ($Z_S=50\Omega$) $V_D=2\text{V}$, $I_C=5\text{mA}$	$F_{50\Omega}$		1.15 1.3		dB
Output power at 1dB gain compression $V_D=2\text{V}$, $I_C=20\text{mA}$, $f=1.8\text{GHz}$ $Z_L=Z_{\text{LOPT}}$ $Z_L=50\Omega$	$P_{-1\text{dB}}$		12 10		dBm
Output third order intercept point $V_D=2\text{V}$, $I_C=20\text{mA}$, $f=1.8\text{GHz}$ $Z_{\text{L/S}}=Z_{\text{L/SOPT}}$ $Z_{\text{L/S}}=50\Omega$	OIP_3		22 20		dBm
Collector-base capacitance $V_{\text{CB}}=2\text{V}$, $f=1\text{MHz}$	C_{CB}		0.15		pF
Current ratio I_C/I_{Bias} $I_{\text{Bias}}=0.5\text{mA}$, $V_D=3\text{V}$	CR	7	10	13	

S-Parameter $V_D=2V$, $I_C=20mA$ (see Electrical Characteristics for conditions)

Frequency [GHz]	S11 Mag	S11 Ang	S21 Mag	S21 Ang	S12 Mag	S12 Ang	S22 Mag	S22 Ang
0.1	0.5387	-17.8	35.6280	158.9	0.0064	75.4	0.9334	-11.8
0.2	0.4744	-35.8	31.0390	142.8	0.0141	76.8	0.8357	-20.9
0.4	0.3724	-60.7	22.5520	120.2	0.0241	75.4	0.6670	-29.7
0.6	0.2992	-74.7	16.8920	108.1	0.0335	75.3	0.5672	-31.0
0.8	0.2453	-88.7	13.3320	98.2	0.0439	74.7	0.5066	-33.0
1.0	0.2205	-100.1	10.9000	91.2	0.0547	73.4	0.4675	-33.8
1.2	0.1900	-111.0	9.1938	85.5	0.0663	71.5	0.4406	-35.1
1.4	0.1765	-122.0	7.9452	80.6	0.0785	69.3	0.4209	-36.8
1.6	0.1648	-132.7	6.9615	76.3	0.0901	66.5	0.4013	-38.7
1.8	0.1660	-142.5	6.2388	72.2	0.1014	63.5	0.3822	-41.5
2.0	0.1737	-153.1	5.6320	68.2	0.1125	60.5	0.3519	-43.6
3.0	0.1966	175.9	3.8040	51.6	0.1655	44.9	0.2868	-57.0
4.0	0.2486	156.8	2.9394	36.2	0.2151	29.1	0.2398	-76.1
5.0	0.3451	136.5	2.4109	20.7	0.2439	9.1	0.1506	-111.0
6.0	0.4645	117.1	2.0318	5.5	0.2362	-7.1	0.1196	168.0

Device Current $I_D = f(V_D, R_{Bias})$

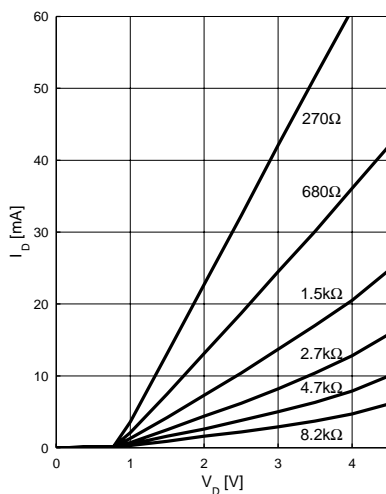

Power Gain $|S_{21}|^2, G_{ma}, G_{ms} = f(f)$
 $V_D = 3V, I_C = 20mA$

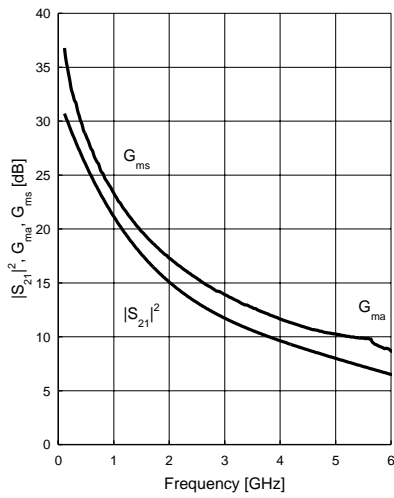

Power Gain $G_{ma}, G_{ms} = f(f)$
 $V_D = 3V$

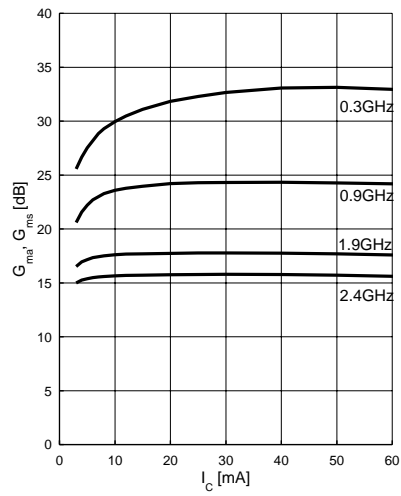

Matching $|S_{11}|, |S_{22}| = f(f)$
 $V_D = 3V, I_C = 20mA$

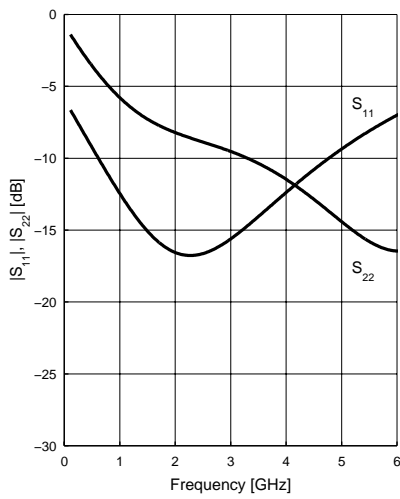

Output Compression Point
 $P_{-1dB} = f(I_C)$
 $V_D = 3V, f = 1.8GHz, Z_L = 50\Omega$

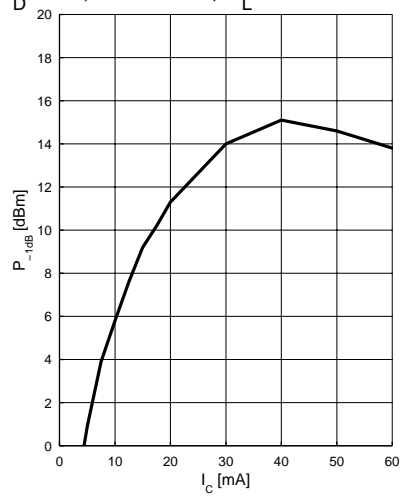

SPICE Model

BGB540-Chip

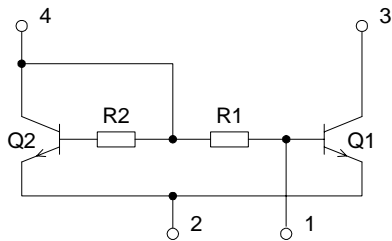

Q1	T513
Q2	T513 (area factor: 0.1)
R1	2.7kΩ
R2	27kΩ

Transistor Chip Data T513 (Berkley-SPICE 2G.6 Syntax)

```
.MODEL T513 NPN(
+ IS = 8.2840e-17      BF = 107.5      NF = 1.0      VAF = 28.383
+ IKF = 0.48731      ISE = 1.115e-11    NE = 3.19     BR = 5.5
+ NR = 1.0           VAR = 19.705      IKR = 0.02    ISC = 1.9237e-17
+ NC = 1.1720       RBM = 1.3      IRB = 0.00072983  RB = 5.4
+ RE = 0.31111     RC = 4.0      CJE = 1.8063e-15  VJE = 0.8051
+ MJE = 0.46576    TF = 6.76e-12  XTF = 0.4219     VTF = 0.23794
+ ITF = 0.001      PTF = 0       CJC = 2.34e-13   VJC = 0.81969
+ MJC = 0.30232    XCJC = 0.3    TR = 2.324E-09   CJS = 0
+ VJS = 0.75       MJS = 0       XTB = 0          EG = 1.11
+ XTI = 3          FC = 0.73234)
```

Package Equivalent Circuit

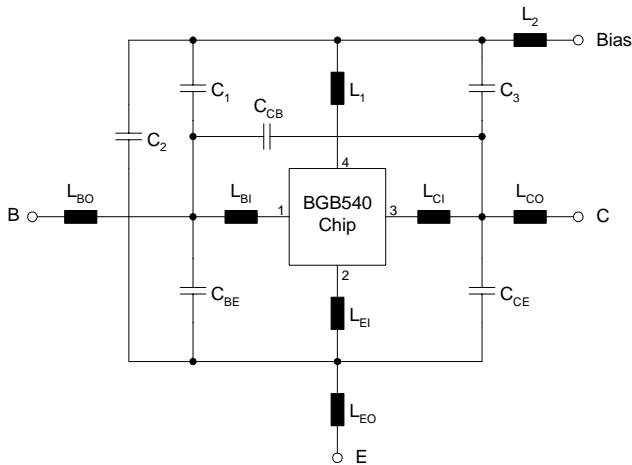

L _{BI}	0.36 nH
L _{BO}	0.42 nH
L _{EI}	0.35 nH
L _{EO}	0.27 nH
L _{CI}	0.56 nH
L _{CO}	0.58 nH
L ₁	0.5 nH
L ₂	0.58 nH
C _{BE}	120 fF
C _{CB}	6.9 fF
C _{CE}	134 fF
C ₁	90 fF
C ₂	120 fF
C ₃	15 fF

Valid up to 3GHz

Typical Application

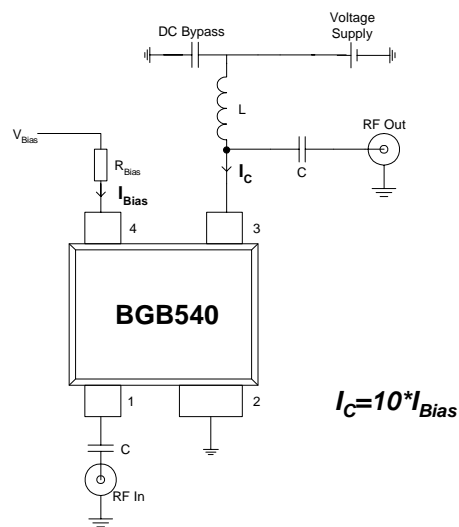

This proposal demonstrates how to use the BGB540 as a Self-Biased Transistor. As for a discrete Transistor matching circuits have to be applied. A good starting point for various applications are the Application Notes provided for the BFP540.

Fig. 3: Typical application circuit

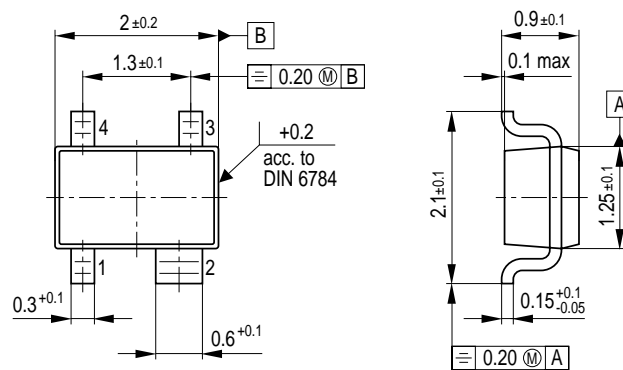

Package Outline



GPS05605

Looking for pricing, stock, or lifecycle information?

Click below to explore more details on WIN SOURCE:

-  [View BGB540E6327 on WIN SOURCE](#)
-  [Infineon Technologies](#) Information

Optimize Your Supply Chain with WIN SOURCE Solutions

-  Global Sourcing Solution
-  Obsolete Management
-  Cost Control Management
-  Shortage Management
-  Alternative Solution
-  Excess Inventory Management