



**THE DATASHEET OF  
AS1C2M16P-70BIN**



**Revision History**

**32M (2M x 16 bit) PSEUDO STATIC RAM**  
**48ball FPBGA Package**

Revision	Details	Date
Rev 1.0	Preliminary datasheet	Aug 2018

## 2Mb x16 Pseudo Static RAM Specification

### GENERAL DESCRIPTION

The AS1C2M16P-70BIN is 33,554,432 bits of Pseudo SRAM which uses DRAM type memory cells, but this device has refresh-free operation and extreme low power consumption technology. Furthermore the interface is compatible to a low power Asynchronous type SRAM. The AS1C2M16P-70BIN is organized as 2,097,152 Words x 16 bit.

### FEATURES

- Organization :2M x16
- Address access speed 70ns
- Power Supply Voltage : 2.6 ~ 3.3V
- Separated I/O power(VccQ) & Core power(Vcc)
- Three state outputs
- Byte read/write control by UB# / LB#
- Auto-TCSR for power saving
- Package type : 48ball-FPBGA (6.0x7.0)
- Operating Temperature
  - . Industrial : -40 °C ~ 85 °C

### PRODUCT FAMILY

Part Number	Operating Temp.	Power Supply	Speed (t <sub>RC</sub> )	Power Dissipation		
				Standby (I <sub>SB</sub> , Max.)	Operating I <sub>CC</sub> ( Max.)	
					I <sub>CC1</sub> ( f = 1MHz)	I <sub>CC2</sub> ( f = f <sub>max</sub> )
AS1C2M16P-70BIN	-40 °C to 85 °C	2.6V to 3.3V	70ns	120uA	5mA	25mA

### FUNCTION BLOCK DIAGRAM

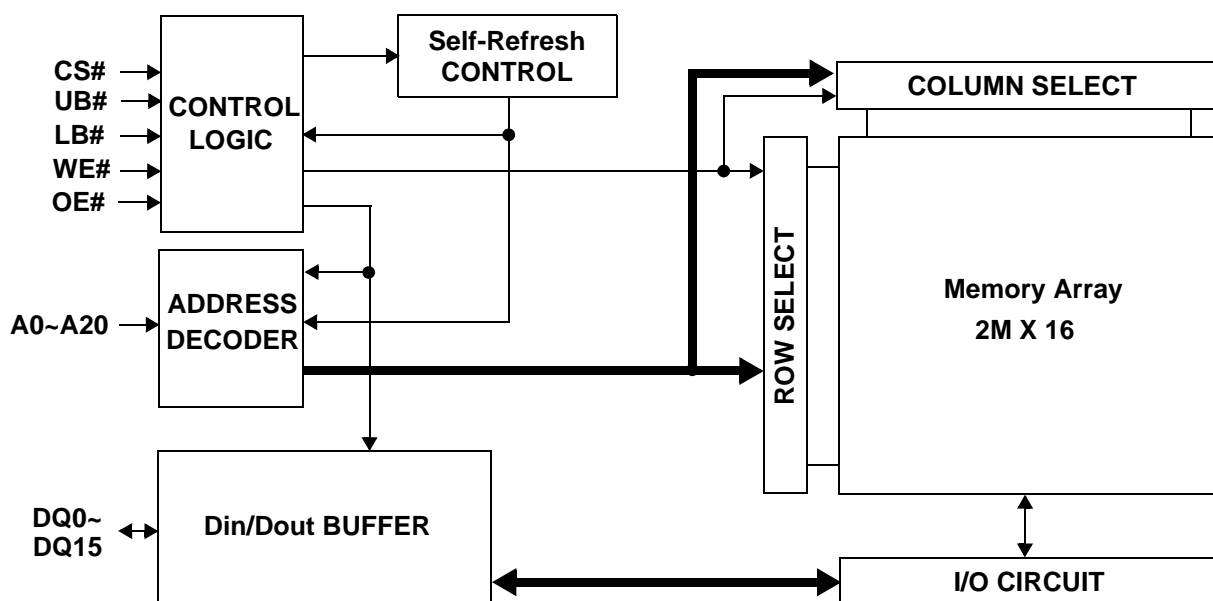

## PIN DESCRIPTION ( 48ball-FPBGA-6.00x7.00 )

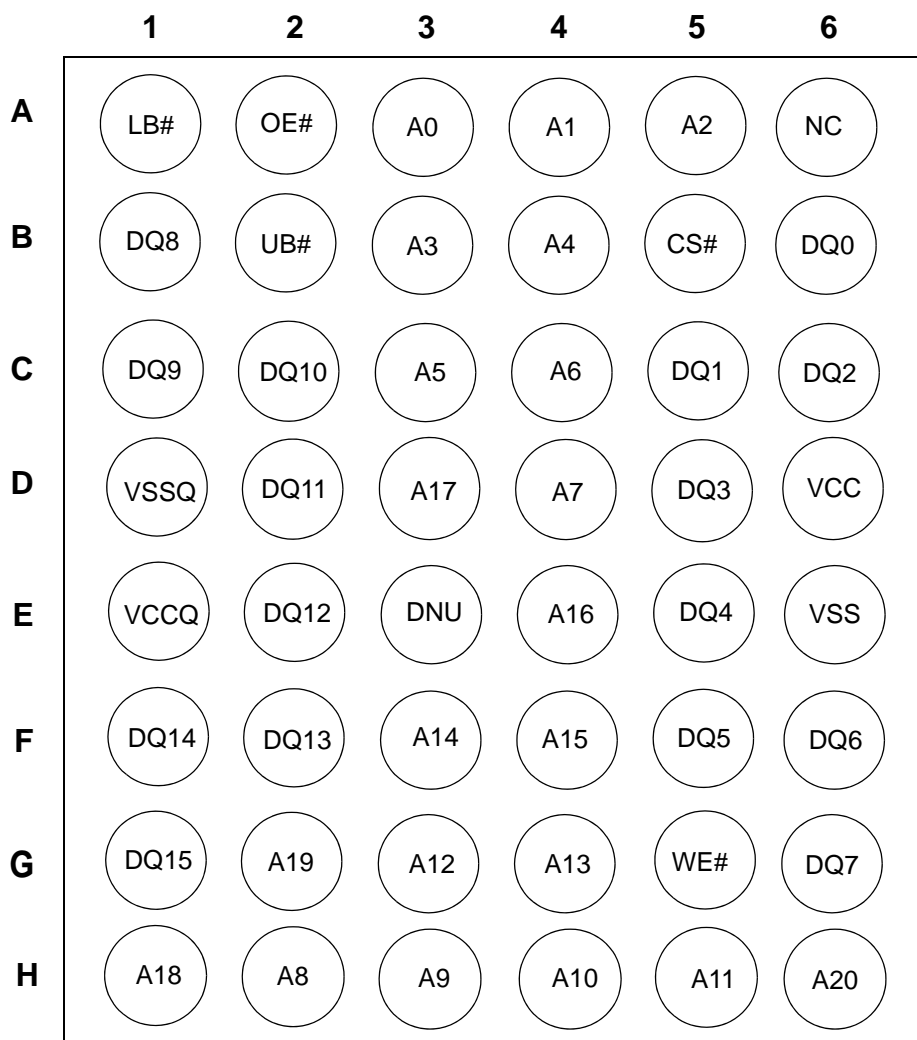

### TOP VIEW (Ball Down)

Name	Function	Name	Function
CS#	Chip select input	LB#	Lower byte (DQ <sub>0-7</sub> )
OE#	Output enable input	UB#	Upper byte (DQ <sub>8-15</sub> )
WE#	Write enable input	VCC	Power supply
DQ <sub>0-15</sub>	Data in-out	VCCQ	I/O power supply
A <sub>0-20</sub>	Address inputs	VSS(Q)	Ground
DNU	Do not use	NC	No connection

## ABSOLUTE MAXIMUM RATINGS <sup>1)</sup>

Parameter	Symbol	Ratings	Unit	
Voltage on Any Pin Relative to V <sub>SS</sub>	V <sub>IN</sub> , V <sub>OUT</sub>	-0.2 to V <sub>CCQ</sub> +0.3V	V	
Voltage on V <sub>CC</sub> supply relative to V <sub>SS</sub>	V <sub>CC</sub> , V <sub>CCQ</sub>	-0.2 <sup>2)</sup> V <sub>CCQ</sub> +0.3V	V	
Power Dissipation	P <sub>D</sub>	1.0	W	
Storage Temperature	T <sub>STG</sub>	-65 to 150	°C	
Operating Temperature	Industrial	T <sub>A</sub>	-40 to 85	°C

- Stresses greater than those listed above "Absolute Maximum Ratings" may cause permanent damage to the device. Functional operation should be restricted to recommended operating condition. Exposure to absolute maximum rating conditions for extended periods may affect reliability.
- Undershoot at power-off : -1.0V in case of pulse width  $\leq$  20ns

## FUNCTIONAL DESCRIPTION

CS#	OE#	WE#	LB#	UB#	DQ <sub>0-7</sub>	DQ <sub>8-15</sub>	Mode	Power
H	X	X	X	X	High-Z	High-Z	Deselected	Stand by
L	H	H	L	X	High-Z	High-Z	Output Disabled	Active
L	H	H	X	L	High-Z	High-Z	Output Disabled	Active
L	L	H	L	H	Data Out	High-Z	Lower Byte Read	Active
L	L	H	H	L	High-Z	Data Out	Upper Byte Read	Active
L	L	H	L	L	Data Out	Data Out	Word Read	Active
L	X	L	L	H	Data In	High-Z	Lower Byte Write	Active
L	X	L	H	L	High-Z	Data In	Upper Byte Write	Active
L	X	L	L	L	Data In	Data In	Word Write	Active

Note:

- X means don't care. (Must be low or high state)

## RECOMMENDED DC OPERATING CONDITIONS

Parameter	Symbol	Min	Typ	Max	Unit
Supply voltage	$V_{CC}$	2.6	3.0	3.3	V
	$V_{CCQ}$	2.6	3.0	3.3	V
Ground	$V_{SS}, V_{SSQ}$	0	0	0	V
Input high voltage	$V_{IH}$	$0.8 * V_{CCQ}$	-	$V_{CCQ} + 0.2^{1)}$	V
Input low voltage	$V_{IL}$	$-0.2^{2)}$	-	$0.2 * V_{CCQ}$	V

1. Overshoot:  $V_{CC} + 1.0$  V in case of pulse width  $\leq 20$ ns
2. Undershoot:  $-1.0$  V in case of pulse width  $\leq 20$ ns
3. Overshoot and undershoot are sampled, not 100% tested.

## CAPACITANCE<sup>1)</sup> ( $f=1$ MHz, $T_A=25^\circ$ C)

Item	Symbol	Test Condition	Min	Max	Unit
Input capacitance	$C_{IN}$	$V_{IN}=0$ V	-	8	pF
Input/Output capacitance	$C_{IO}$	$V_{IO}=0$ V	-	8	pF

1. Capacitance is sampled, not 100% tested

## DC AND OPERATING CHARACTERISTICS

Parameter	Symbol	Test Conditions	Min	Typ	Max	Unit
Input leakage current	$I_{LI}$	$V_{IN}=V_{SS}$ to $V_{CCQ}$ , $V_{CC}=V_{CCmax}$	-1	-	1	$\mu$ A
Output leakage current	$I_{LO}$	$CS\#=V_{IH}$ , $OE\#=V_{IH}$ or $WE\#=V_{IL}$ , $V_{IO}=V_{SS}$ to $V_{CCQ}$ , $V_{CC}=V_{CCmax}$	-1	-	1	$\mu$ A
Average operating current	$I_{CC1}$	Cycle time = 1 $\mu$ s, $I_{IO}=0$ mA, 100% duty, $CS\#\leq 0.2$ V, , $V_{IN}\leq 0.2$ V or $V_{IN}\geq V_{CCQ}-0.2$ V	-	-	5	mA
	$I_{CC2}$	Cycle time = Min, $I_{IO}=0$ mA, 100% duty, $CS\#=V_{IL}$ , $V_{IN}=V_{IL}$ or $V_{IH}$	-	-	25	mA
Output low voltage	$V_{OL}$	$I_{OL} = 0.5$ mA, $V_{CC}=V_{CCmin}$	-	-	$0.2 * V_{CCQ}$	V
Output high voltage	$V_{OH}$	$I_{OH} = -0.5$ mA, $V_{CC}=V_{CCmin}$	$0.8 * V_{CCQ}$	-	-	V
Standby current (CMOS)	$I_{SB}$	$CS\#\geq V_{CCQ}-0.2$ V, Other inputs = 0 ~ $V_{CCQ}$ (Typ. condition : $V_{CC}=3.0$ V @ $25^\circ$ C) (Max. condition : $V_{CC}=3.3$ V @ $85^\circ$ C)	-	-	120	$\mu$ A

1. Maximum  $I_{CC}$  specifications are tested with  $V_{CC} = V_{CCmax}$ .

## AC OPERATING CONDITIONS

Test Conditions (Test Load and Test Input/Output Reference)

Input Pulse Level : 0.2V to  $V_{CCQ}-0.2V$

Input Rise and Fall Time : 5ns

Input and Output reference Voltage :  $V_{CCQ}/2$

Output Load (See right) :  $CL^{(1)} = 30pF$

1. Including scope and Jig capacitance

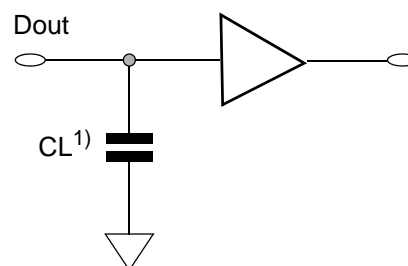

## AC CHARACTERISTICS

Parameter List		Symbol	Speed		Unit
			Min	Max	
Read	Read Cycle Time	$t_{RC}$	70	10k	ns
	Address access time	$t_{AA}$	-	70	ns
	Chip enable to data output	$t_{CO}$	-	70	ns
	Output enable to valid output	$t_{OE}$	-	25	ns
	UB#, LB# enable to data output	$t_{BA}$	-	25	ns
	Chip enable to low-Z output	$t_{LZ}$	10	-	ns
	UB#, LB# enable to low-Z output	$t_{BLZ}$	0	-	ns
	Output enable to low-Z output	$t_{OLZ}$	0	-	ns
	Chip disable to high-Z output	$t_{HZ}$	0	20	ns
	UB#, LB# disable to high-Z output	$t_{BHZ}$	0	20	ns
	Output disable to high-Z output	$t_{OHZ}$	0	20	ns
	Output hold from Address change	$t_{OH}$	5	-	ns
Write	Write Cycle Time	$t_{WC}$	70	10k	ns
	Chip enable to end of write	$t_{CW}$	60	-	ns
	Address setup time	$t_{AS}$	0	-	ns
	Address valid to end of write	$t_{AW}$	60	-	ns
	UB#, LB# valid to end of write	$t_{BW}$	60	-	ns
	Write pulse width	$t_{WP}$	50	-	ns
	Write recovery time	$t_{WR}$	0	-	ns
	Write to output high-Z	$t_{WHZ}$	0	20	ns
	Data to write time overlap	$t_{DW}$	20	-	ns
	Data hold from write time	$t_{DH}$	0	-	ns
	End write to output low-Z	$t_{OW}$	5	-	ns

## TIMING DIAGRAMS

**READ CYCLE (1)** (Address controlled, CS#=OE#=V<sub>IL</sub>, WE#=V<sub>IH</sub>, UB# or/and LB#=V<sub>IL</sub>)

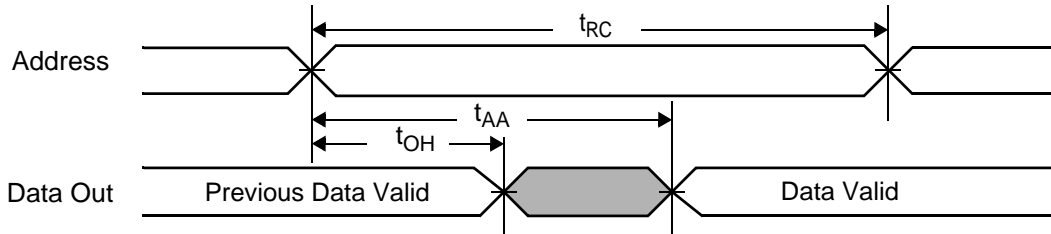

**READ CYCLE (2)** (WE#=V<sub>IH</sub>)

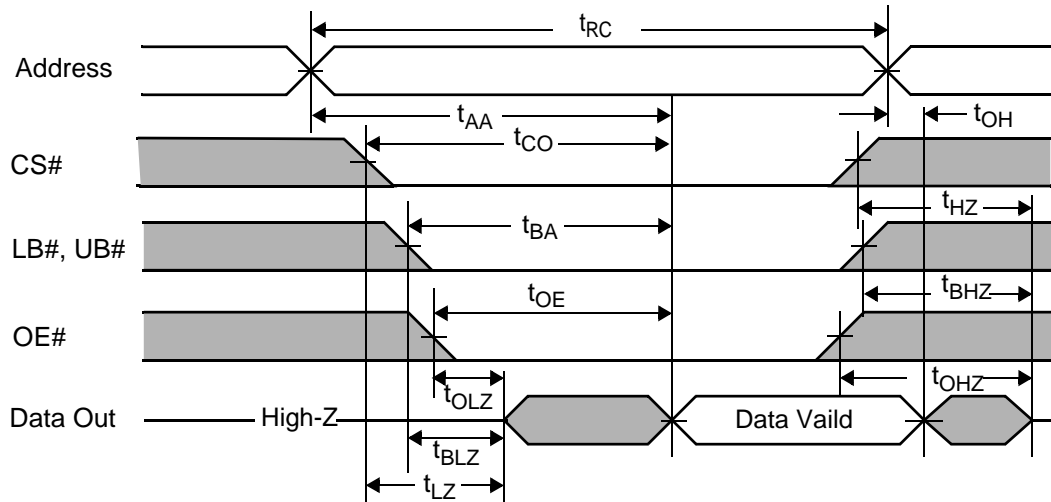

**NOTES (READ CYCLE)**

1.  $t_{HZ}$ ,  $t_{BHZ}$  and  $t_{OHZ}$  are defined as the time at which the outputs achieve the open circuit conditions and are not referenced to output voltage levels.
2. Do not Access device with cycle timing shorter than  $t_{RC}$  for continuous periods > 10 $\mu$ s.

### WRITE CYCLE (1) (WE# controlled)

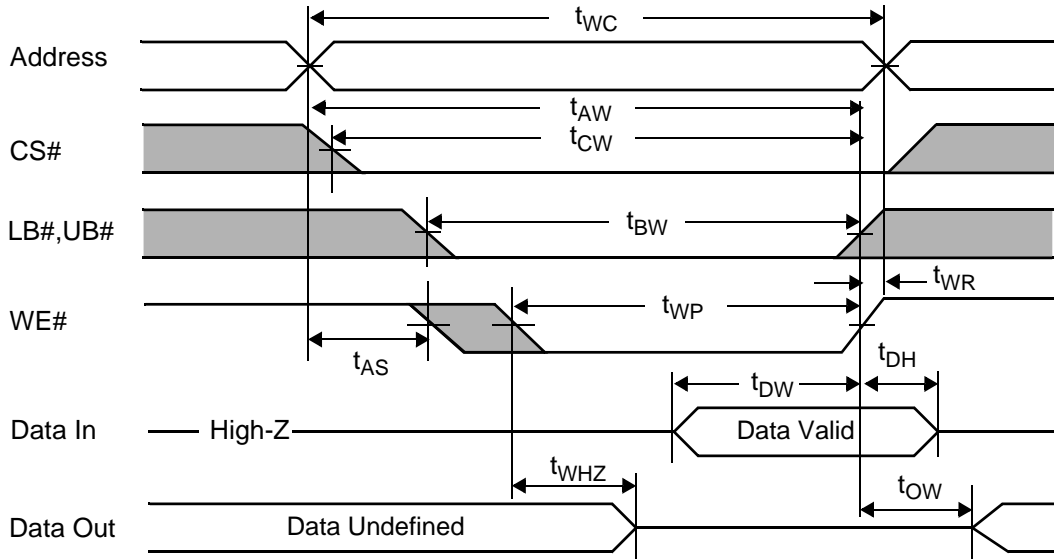

### WRITE CYCLE (2) (CS# controlled)

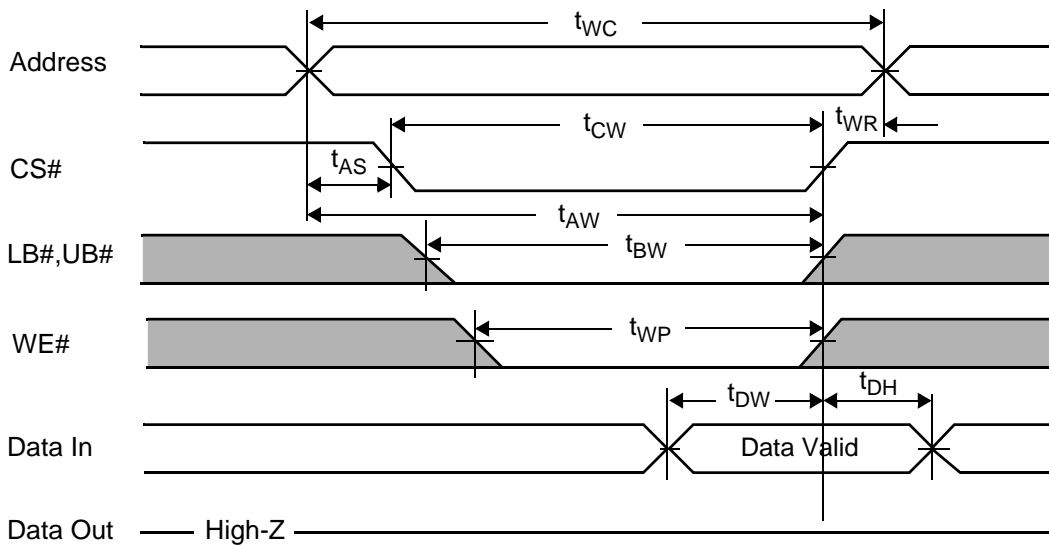

### WRITE CYCLE (3) (UB#/LB# controlled)

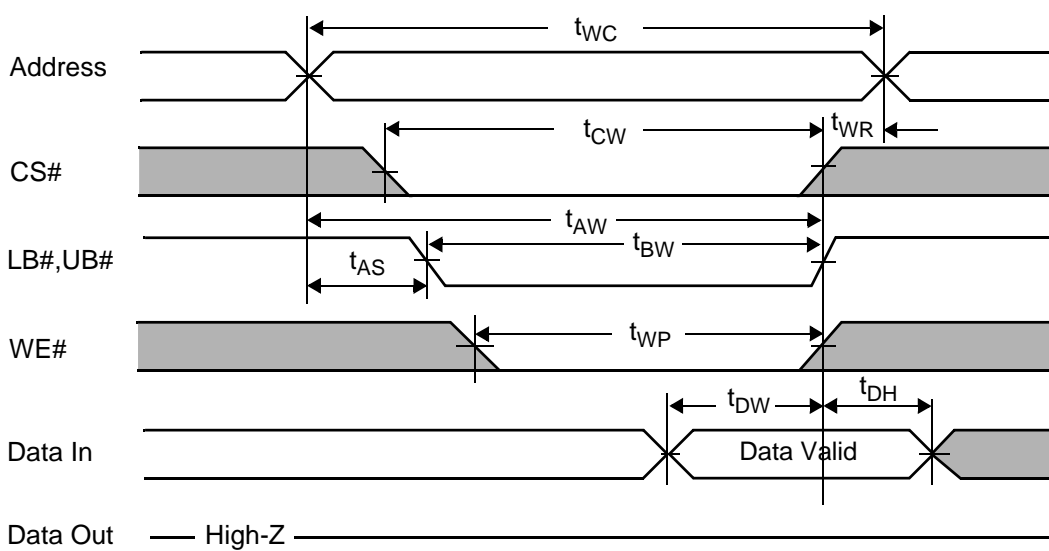

**NOTES (WRITE CYCLE)**

1. A write occurs during the overlap( $t_{WP}$ ) of low CS#, low WE# and low UB# or LB#. A write begins at the last transition among low CS# and low WE# with asserting UB# or LB# low for single byte operation or simultaneously asserting UB# and LB# low for word operation. A write ends at the earliest transition among high CS# and high WE#. The  $t_{WP}$  is measured from the beginning of write to the end of write.
2.  $t_{CW}$  is measured from CS# going low to end of write.
3.  $t_{AS}$  is measured from the address valid to the beginning of write.
4.  $t_{WR}$  is measured from the end of write to the address change.  $t_{WR}$  applied in case a write ends as CS# or WE# going high.
5. Do not access device with cycle timing shorter than  $t_{WC}$  for continuous periods > 10us.

## TIMING WAVEFORM OF POWER UP

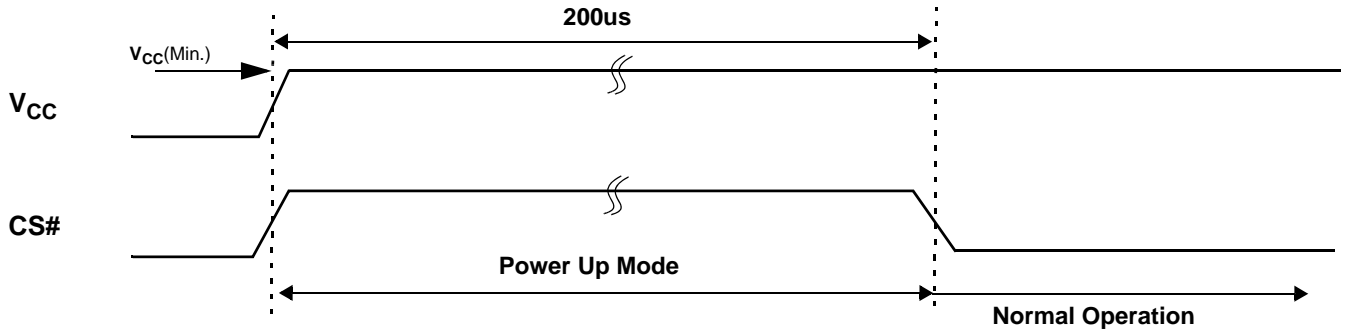

### NOTE ( POWER UP )

1. After  $V_{CC}$  reaches  $V_{CC}(\text{Min.})$  , wait 200us with  $CS\#$  high. Then you get into the normal operation.

## PACKAGE DIMENSION

48 Ball Fine Pitch BGA (0.75mm ball pitch)

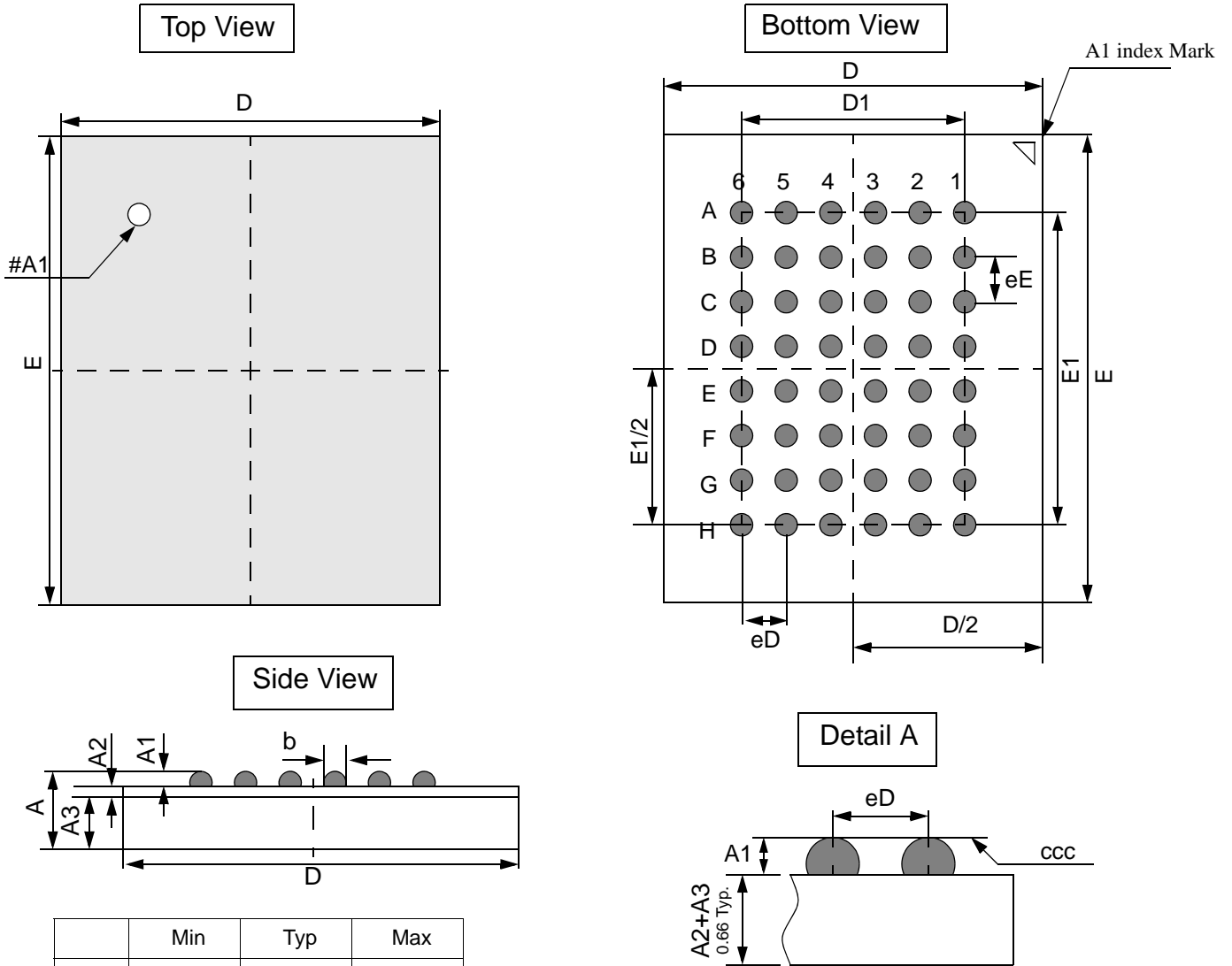

	Min	Typ	Max
A	-	0.87	1.00
A1	0.22	-	0.32
A2	-	0.21	-
A3	-	0.45	-
b	0.35	-	0.45
D	5.90	6.00	6.10
E	6.90	7.00	7.10
D1	-	3.75	-
E1	-	5.25	-
eE	-	0.75	-
eD	-	0.75	-
ccc	-	-	0.08

### NOTES.

1. Bump counts : 48(8row x 6column)
2. Bump pitch : (x,y)=(0.75x0.75) (typ.)
3. All tolerance are +/-0.050 unless otherwise specified.
4. Typ : Typical
5. ccc is coplanarity : 0.08(Max)
6. POST REFLOW ARE IN MILLIMETER.  
(Pre Reflow Diameter : 0.35 +\_ 0.02)
7. TOLERANCE INCLUDES WARPAGE.

## PART NUMBERING SYSTEM

AS1C	2M16P	-70	B	I	N	XX
PSEUDO SRAM	2M16=2Mx16 P=PSEUDO SRAM	70ns	B = FBGA	I=Industrial (-40° C~+85° C)	Indicates Pb and Halogen Free	PackingType None:Tray TR:Reel





Alliance Memory, Inc.  
 511 Taylor Way,  
 San Carlos, CA 94070  
 Tel: 650-610-6800  
 Fax: 650-620-9211  
[www.alliancememory.com](http://www.alliancememory.com)

Copyright © Alliance Memory  
 All Rights Reserved

© Copyright 2007 Alliance Memory, Inc. All rights reserved. Our three-point logo, our name and Intelliwatt are trademarks or registered trademarks of Alliance. All other brand and product names may be the trademarks of their respective companies. Alliance reserves the right to make changes to this document and its products at any time without notice. Alliance assumes no responsibility for any errors that may appear in this document. The data contained herein represents Alliance's best data and/or estimates at the time of issuance. Alliance reserves the right to change or correct this data at any time, without notice. If the product described herein is under development, significant changes to these specifications are possible. The information in this product data sheet is intended to be general descriptive information for potential customers and users, and is not intended to operate as, or provide, any guarantee or warrantee to any user or customer. Alliance does not assume any responsibility or liability arising out of the application or use of any product described herein, and disclaims any express or implied warranties related to the sale and/or use of Alliance products including liability or warranties related to fitness for a particular purpose, merchantability, or infringement of any intellectual property rights, except as express agreed to in Alliance's Terms and Conditions of Sale (which are available from Alliance). All sales of Alliance products are made exclusively according to Alliance's Terms and Conditions of Sale. The purchase of products from Alliance does not convey a license under any patent rights, copyrights; mask works rights, trademarks, or any other intellectual property rights of Alliance or third parties. Alliance does not authorize its products for use as critical components in life-supporting systems where a malfunction or failure may reasonably be expected to result in significant injury to the user, and the inclusion of Alliance products in such life-supporting systems implies that the manufacturer assumes all risk of such use and agrees to indemnify Alliance against all claims arising from such use.

## Looking for pricing, stock, or lifecycle information?

Click below to explore more details on WIN SOURCE:

-  [View AS1C2M16P-70BIN on WIN SOURCE](#)
-  [Alliance Memory, Inc. Information](#)

## Optimize Your Supply Chain with WIN SOURCE Solutions

-  Global Sourcing Solution
-  Obsolete Management
-  Cost Control Management
-  Shortage Management
-  Alternative Solution
-  Excess Inventory Management