



**THE DATASHEET OF
BLA31AG121SN4D**



Chip Ferrite Bead Array**BLA31****SN4****Reference Specification****1. Scope**

This reference specification applies to Chip Ferrite Bead Array BLA31 Series used for electronic machinery.

2. Part Numbering

(ex.)	<u>BL</u>	<u>A</u>	<u>31</u>	<u>AG</u>	<u>121</u>	<u>S</u>	<u>N</u>	<u>4</u>	<u>D</u>
	(1)	(2)	(3)	(4)	(5)	(6)	(7)	(8)	(9)
	(1)Product ID					(6)Performance			
	(2)Type					(7)Category			
	(3)Dimension (L×W)					(8)Numbers of Circuit			
	(4)Characteristics					(9)Packaging (D:Taping / B:Bulk)			
	(5)Typical Impedance at 100MHz								

3. Rating

Customer Part Number	MURATA Part Number	Impedance (Ω) at 100MHz, Under Standard Testing Condition)	Rated Current (mA)	DC Resistance (Ω max.)		Insulation Resistance between Elements	Remark
				Initial Values	Values After Testing		
	BLA31AG300SN4D	30±25%	200	0.10	0.20	100M Ω min.	For general use
	BLA31AG300SN4B						
	BLA31AG600SN4D	60±25%	200	0.15	0.25		
	BLA31AG600SN4B						
	BLA31AG121SN4D	120±25%	150	0.20	0.30		
	BLA31AG121SN4B						
	BLA31AG221SN4D	220±25%	150	0.25	0.35		
	BLA31AG221SN4B						
	BLA31AG601SN4D	600±25%	100	0.35	0.45		
	BLA31AG601SN4B						
	BLA31AG102SN4D	1000±25%	50	0.45	0.55		
	BLA31AG102SN4B						
	BLA31BD121SN4D	120±25%	150	0.30	0.40		For high speed signal line
	BLA31BD121SN4B						
	BLA31BD221SN4D	220±25%	150	0.35	0.45		
	BLA31BD221SN4B						
	BLA31BD471SN4D	470±25%	100	0.40	0.50		
	BLA31BD471SN4B						
	BLA31BD601SN4D	600±25%	100	0.45	0.55		
	BLA31BD601SN4B						
	BLA31BD102SN4D	1000±25%	50	0.55	0.65		
	BLA31BD102SN4B						

· Operating Temperature : -55°C to +125°C · Storage Temperature : -55°C to +125°C

4. Style and Dimensions

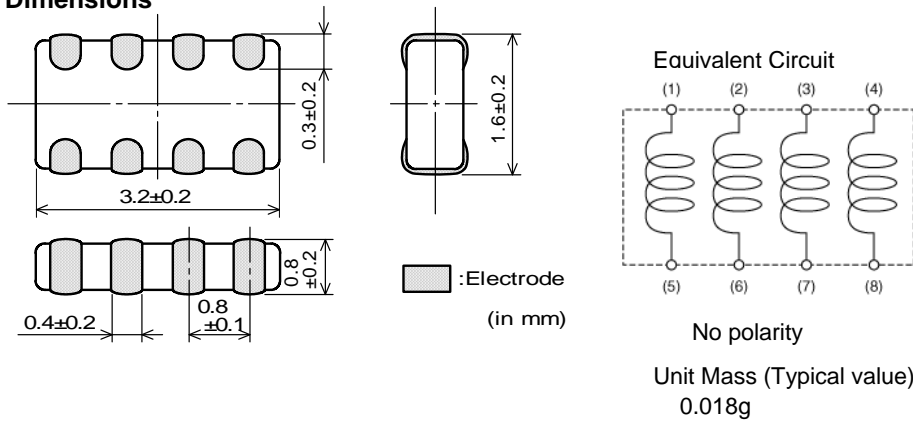

5. Marking

No marking.

6. Standard Testing Conditions

< Unless otherwise specified >

Temperature : Ordinary Temp. (15 °C to 35 °C)
Humidity : Ordinary Humidity (25%(RH) to 85%(RH))

< In case of doubt >

Temperature : 20°C±2 °C
Humidity : 60%(RH) to 70%(RH)
Atmospheric pressure : 86kPa to 106kPa

7. Electrical Performance

No.	Item	Specification	Test Method
7.1	Impedance	Meet item 3.	Measuring Frequency : 100 MHz ± 1 MHz Measuring Equipment : Agilent 4291A or the equivalent (OSC = 0.05 V) Test Fixture : Agilent 16192A
7.2	DC Resistance		Measuring Equipment : Digital multi meter
7.3	Insulation Resistance between Elements		Measuring Voltage : 5 V(DC) Measuring Time : 1 min max.

8. Mechanical Performance

No.	Item	Specification	Test Method						
8.1	Appearance and Dimensions	Meet item 4.	Visual Inspection and measured with Slide Calipers.						
8.2	Bonding Strength	Meet Table 1. <table border="1"> <caption>Table 1</caption> <tr> <td>Appearance</td> <td>No damage</td> </tr> <tr> <td>Impedance Change (at 100MHz)</td> <td>Within ±30%</td> </tr> <tr> <td>DC Resistance</td> <td>Meet item 3.</td> </tr> </table>	Appearance	No damage	Impedance Change (at 100MHz)	Within ±30%	DC Resistance	Meet item 3.	It shall be soldered on the substrate. Applying Force(F) : 9.8 N Applying Time : 5s ± 1s
Appearance	No damage								
Impedance Change (at 100MHz)	Within ±30%								
DC Resistance	Meet item 3.								
8.3	Bending Strength		It shall be soldered on the substrate. Substrate : Glass-epoxy substrate (100mm × 40mm × 1.0mm) Deflection : 2.0 mm Speed of Applying Force : 0.5 mm / s Keeping Time : 30 s 						

No.	Item	Specification	Test Method
8.4	Solderability	The electrodes shall be at least 95% covered with new solder coating.	Flux : Ethanol solution of rosin, 25 (wt)% Pre-Heating : 150 °C ± 10 °C, 60 s ~ 90 s Solder : Sn-3.0Ag-0.5Cu Solder Temperature : 240 °C ± 5 °C Immersion Time 3 s ± 1 s Immersion and emersion rates : 25mm / s
8.5	Resistance to Soldering Heat	Meet Table 1.	Flux : Ethanol solution of rosin, 25 (wt)% Pre-Heating : 150 °C ± 10 °C, 60 s ~ 90 s Solder Sn-3.0Ag-0.5Cu Solder Temperature : 270 °C ± 5 °C Immersion Time : 10 s ± 1 s Immersion and emersion rates : 25mm / s Then measured after exposure in the room condition for 48h ± 4h.
8.6	Vibration		It shall be soldered on the substrate. Oscillation Frequency : 10Hz to 55Hz to 10Hz for 1 min Total Amplitude : 1.5 mm Testing Time : A period of 2 hours in each of 3 mutually perpendicular directions.
8.7	Drop	Products shall be no failure after tested.	It shall be dropped on concrete or steel board. Method : free fall Height : 75 cm Attitude from which the product is dropped : 3 directions The Number of Time : 3 times for each direction (Total 9 times)

9. Environmental Performance (It shall be soldered on the substrate.)

No.	Item	Specification	Test Method
9.1	Temperature Cycle	Meet Table 1.	1 cycle: 1 step : -55 °C(+0 °C,-3 °C) / 30min ± 3min 2 step : Ordinary temp. / 10min to 15min 3 step : +125 °C(+3 °C,-0 °C) / 30min ± 3min 4 step:Ordinary temp. / 10min to 15min Total of 100 cycles Then measured after exposure in the room condition for 48h ± 4h.
9.2	Humidity		Temperature : 40 °C ± 2 °C Humidity : 90 %(RH) to 95 %(RH) Time : 1000h (+48h, -0h) Then measured after exposure in the room condition for 48h ± 4h.
9.3	Heat Life		Temperature : 125 °C ± 3 °C Applying Current : Rated Current Time : 1000h (+48h, -0h) Then measured after exposure in the room condition for 48h ± 4h.
9.4	Cold Resistance		Temperature : - 55 ± 2 °C Time : 1000h (+48h, -0h) Then measured after exposure in the room condition for 48h ± 4h.

(5) Outside package

These reels shall be packed in the corrugated cardboard package and the following items shall be marked on a label and the label is stuck on the box.

(Customer name, Purchasing Order Number, Customer Part Number, MURATA part number, RoHS marking (*2) , Quantity , etc)

(6) Dimensions of reel and taping(leader-tape, trailer-tape)

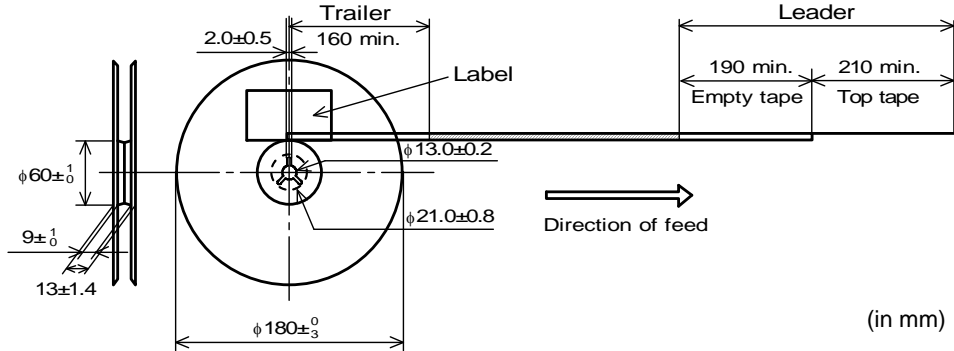

10-4. Specification of Outer Case

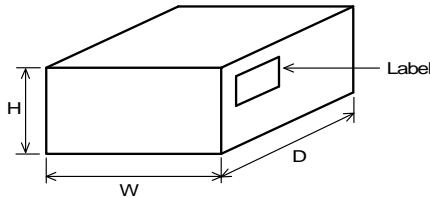

Outer Case Dimensions (mm)			Standard Reel Quantity in Outer Case (Reel)
W	D	H	
186	186	93	5

* Above Outer Case size is typical. It depends on a quantity of an order.

11. Caution

11.1. Surge current

Excessive surge current (pulse current or rush current) than specified rated current applied to the product may cause a critical failure, such as an open circuit, burnout caused by excessive temperature rise.

Please contact us in advance in case of applying the surge current.

11.2. Limitation of Applications

Please contact us before using our products for the applications listed below which require especially high reliability for the prevention of defects which might directly cause damage to the third party's life, body or property.

- | | |
|-----------------------------------|--|
| (1) Aircraft equipment | (6) Disaster prevention / crime prevention equipment |
| (2) Aerospace equipment | (7) Traffic signal equipment |
| (3) Undersea equipment | (8) Transportation equipment (vehicles, trains, ships, etc.) |
| (4) Power plant control equipment | (9) Data-processing equipment |
| (5) Medical equipment | (10) Application of similar complexity and/or with reliability requirements to the applications listed in the above. |

12. Notice

This product is designed for solder mounting.

Please consult us in advance for applying other mounting method such as conductive adhesive.

12.1. Land pattern designing

· Standard land dimensions (Flow and Reflow soldering)

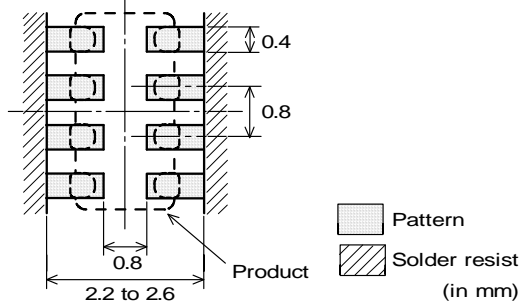

* The excessive heat by land pads may cause deterioration at joint of products with substrate.

12.2. Soldering Conditions

Products can be applied to reflow and flow soldering.

(1) Flux, Solder

Flux	Use rosin-based flux, but not highly acidic flux (with chlorine content exceeding 0.2(wt)%.) Do not use water-soluble flux.
Solder	Use Sn-3.0Ag-0.5Cu solder Standard thickness of solder paste : 100 μm to 200 μm Use of Sn-Zn based solder will deteriorate performance of products. In case of using Sn-Zn based solder, please contact Murata in advance.

(2) Soldering conditions

· Pre-heating should be in such a way that the temperature difference between solder and ferrite surface is limited to 150 °C max. Also cooling into solvent after soldering should be in such a way that the temperature difference is limited to 100 °C max.

Insufficient pre-heating may cause cracks on the ferrite, resulting in the deterioration of product quality.

· Standard soldering profile and the limit soldering profile is as follows.

The excessive limit soldering conditions may cause leaching of the electrode and / or resulting in the deterioration of product quality.

Flow soldering profile

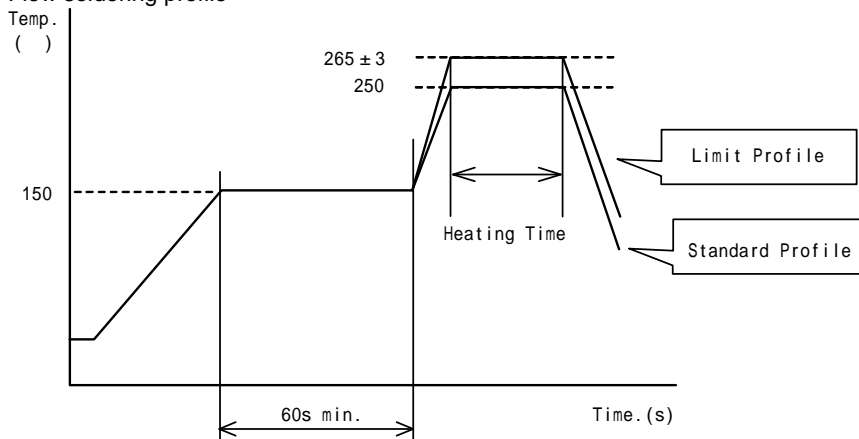

	Standard Profile	Limit Profile
Pre-heating	150°C , 60s min.	
Heating	250°C、 4~6s	265±3°C、 5s max.
Cycle of flow	2 times	2 times

Reflow soldering profile

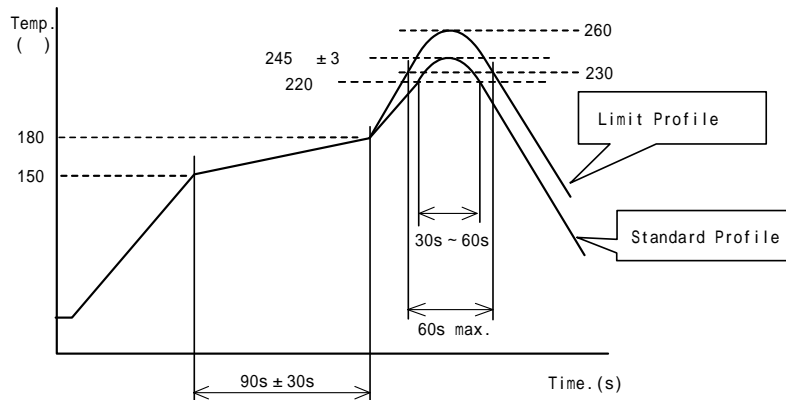

	Standard Profile	Limit Profile
Pre-heating	150 ~ 180°C、90s ± 30s	
Heating	above 220°C、30s ~ 60s	above 230°C、60s max.
Peak temperature	245 ± 3°C	260°C、10s
Cycle of reflow	2 times	2 times

12.3. Reworking with soldering iron

- Pre-heating : 150 °C , 1 min
- Soldering iron output : 80 W max.
- Tip temperature: 350°C max.
- Tip diameter : φ 3mm max.
- Soldering time : 3 (+1, -0) seconds.
- Times : 2times max.

Note : Do not directly touch the products with the tip of the soldering iron in order to prevent the crack on the ferrite material due to the thermal shock.

12.4. Solder Volume

Solder shall be used not to be exceeded as shown below.
Accordingly increasing the solder volume, the mechanical stress to product is also increased.
Exceeding solder volume may cause the failure of mechanical or electrical performance.

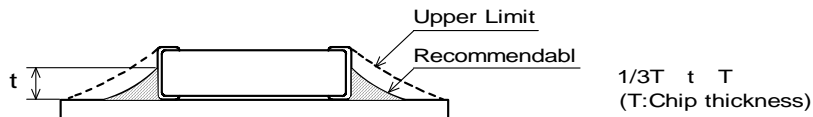

12.5. Attention regarding P.C.B. bending

The following shall be considered when designing and laying out P.C.B.'s.

- (1) P.C.B. shall be designed so that products are not subject to the mechanical stress for board warpage.
<Products direction>

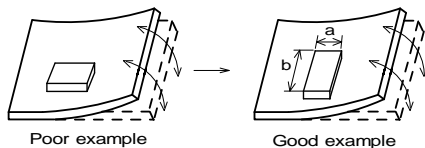

Products shall be located in the sideways direction (Length : a < b) to the mechanical stress.

- (2) Products location on P.C.B. separation.
Products (A,B,C,D) shall be located carefully so that products are not subject to the mechanical stress due to warping the board.
Because they may be subjected the mechanical stress in order of A > C > B ≅ D.

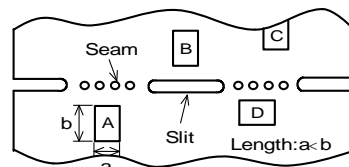

12.6. Potential between Elements

Products should be used within 5 V (DC) between elements.
When the products are used the excessive voltage over 5 V (DC) , it may cause breaking of inner electrode and / or decreasing of insulation resistance between elements.

12.7. Mounting density

Add special attention to radiating heat of products when mounting the inductor near the products with heating. The excessive heat by other products may cause deterioration at joint of this product with substrate.

12.8. Cleaning Conditions

Products shall be cleaned on the following conditions.

- (1) Cleaning temperature shall be limited to 60 °C max. (40 °C max. for IPA.)
- (2) Ultrasonic cleaning shall comply with the following conditions, avoiding the resonance phenomenon at the mounted products and P.C.B.
Power : 20 W / l max. Frequency : 28 kHz to 40 kHz Time : 5 min max.
- (3) Cleaner
 - 1.Cleaner
 - Isopropyl alcohol (IPA)
 - 2.Aqueous agent
 - PINE ALPHA ST-100S
- (4) There shall be no residual flux and residual cleaner after cleaning.
In the case of using aqueous agent, products shall be dried completely after rinse with de-ionized water in order to remove the cleaner.
- (5) Other cleaning
Please contact us.

12.9. Handling of a substrate

After mounting products on a substrate, do not apply any stress to the product caused by bending or twisting to the substrate when cropping the substrate, inserting and removing a connector from the substrate or tightening screw to the substrate.

Excessive mechanical stress may cause cracking in the product.

Bending

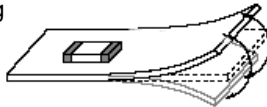

Twisting

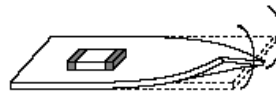
**12.10. Operating Environment**

Do not use this product under the following environmental conditions, on deterioration of the Insulation Resistance of the Ferrite material and/or corrosion of Inner Electrode may result from the use.

- (1) in the corrodible atmosphere (acidic gases, alkaline gases, chlorine, sulfur gases, organic gases and etc.)
- (2) in the atmosphere where liquid such as organic solvent, may splash on the products.
- (3) in the atmosphere where the temperature / humidity changes rapidly and it is easy to dew.

12.11. Resin coating

The impedance value may change and/or it may affect on the product's performance due to high cure-stress of resin to be used for coating / molding products. So please pay your careful attention when you select resin. In prior to use, please make the reliability evaluation with the product mounted in your application set.

12.12. Storage Conditions

- (1) Storage period
Use the products within 6 months after delivered.
Solderability should be checked if this period is exceeded.
- (2) Storage conditions
 - Products should be stored in the warehouse on the following conditions.
Temperature : - 10 °C to 40 °C
Humidity : 15 % to 85 % relative humidity
No rapid change on temperature and humidity
 - Don't keep products in corrosive gases such as sulfur, chlorine gas or acid, or it may cause oxidization of electrode, resulting in poor solderability.
 - Products should be stored on the palette for the prevention of the influence from humidity, dust and so on.
 - Products should be stored in the warehouse without heat shock, vibration, direct sunlight and so on.
 - Products should be stored under the airtight packaged condition.
- (3) Delivery
Care should be taken when transporting or handling product to avoid excessive vibration or mechanical shock.

13. ⚠ Notes

- (1) Please make sure that your product has been evaluated in view of your specifications with our product being mounted to your product.
- (2) You are requested not to use our product deviating from the reference specifications.
- (3) The contents of this reference specification are subject to change without advance notice. Please approve our product specifications or transact the approval sheet for product specifications before ordering.

Looking for pricing, stock, or lifecycle information?

Click below to explore more details on WIN SOURCE:

- [View BLA31AG121SN4D on WIN SOURCE](#)
- [Murata Electronics North America Information](#)

Optimize Your Supply Chain with WIN SOURCE Solutions

- ✓ Global Sourcing Solution
- ✓ Obsolete Management
- ✓ Cost Control Management
- ✓ Shortage Management
- ✓ Alternative Solution
- ✓ Excess Inventory Management