

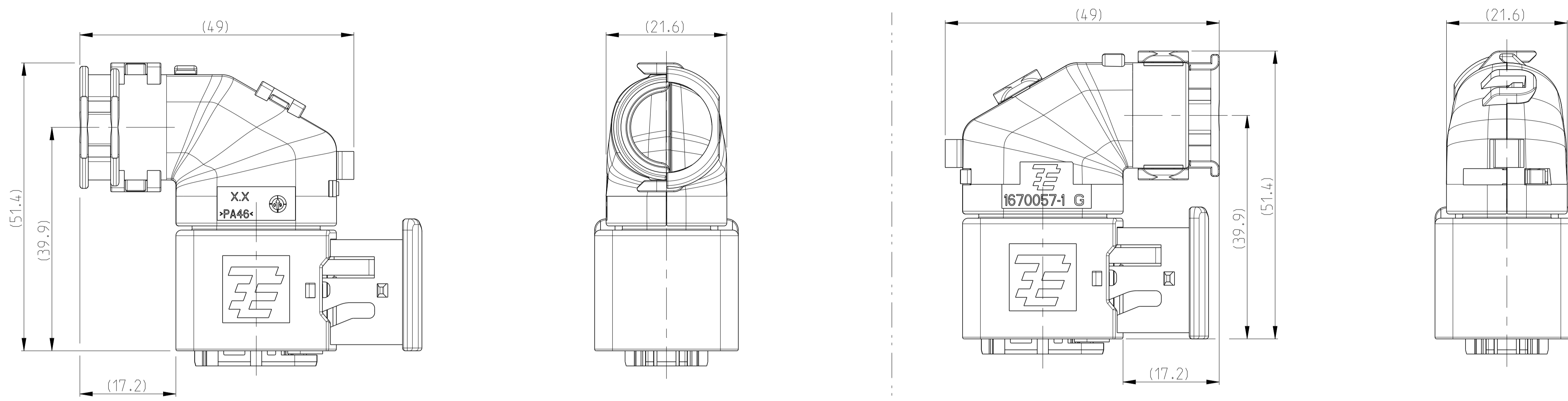

**THE DATASHEET OF**  
**1670057-1**



11 MOUNTED COVER OPTIONS  
 Befestigungsmoeglichkeiten der Kappe



REVISIONS					
P	LTN	DESCRIPTION	DATE	DMN	APVD
G		ECR-09-012157 (PCN E-09-005080 PART CHANG.)	04MAR2009	SJ	CE
G1		DETAILS SEE PCN E-10-002668	04FEB2010	SJ	JG
G2		New view added with TE Logo depending on mold	28NOV2017	MAH	GILC

NOTES  
 Bemerkungen

- 1 TE LOGO  
TE Logo
- 2 TE ORDER-NO.  
TE Bestell-Nr.
- 3 PRODUCTION DATE  
Produktionsdatum
- 4 LETTER-INSERT FOR THE REVISION STATUS OF THE MOLD  
Schriftsatz fuer Aenderungszustand des Werkzeuges  
ACTUAL STATUS: SEE TABLE  
Aktueller Stand: siehe Tabelle
- 5 MATERIAL MARKING ACCORDING TO VDA 260  
Werkstoffkennzeichnung nach VDA 260
- 6 BULK PACKAGING IN CORRUGATED BOX  
Schuetztgut im Versandkarton
- 7 CABLE EXIT DESIGNED FOR CORRUGATED TUBE NW 13  
Kabelabgang ausgelegt fuer Wellrohr NW 13
- 8 MALFUNCTION CAUSED BY LAQUER IS NOT COVERED  
BY TE WARRANTY  
Funktionsbeeintraechtigung durch Lackieren liegt nicht  
im Einfluss und Gewährleistungsumfang von TE
- 9 WARPAGE UP TO -1.0mm FROM NOM. DIMENSION PERMITTED  
Verzug zulaessig bis -1.0mm vom Nennmass
- 10 MAX. CABLE TIE WIDTH: 3.8mm  
max. Kabelbinderbreite: 3.8mm
- 11 SUITABLE FOR TAB AND RECEPTACLE HOUSING GROUP C  
SEE PRODUCT GROUP DRAWING 1563709  
Passend fuer Flachstecker- und Buchsengehäuse der Gruppe C  
siehe Produktgruppenzeichnung 1563709

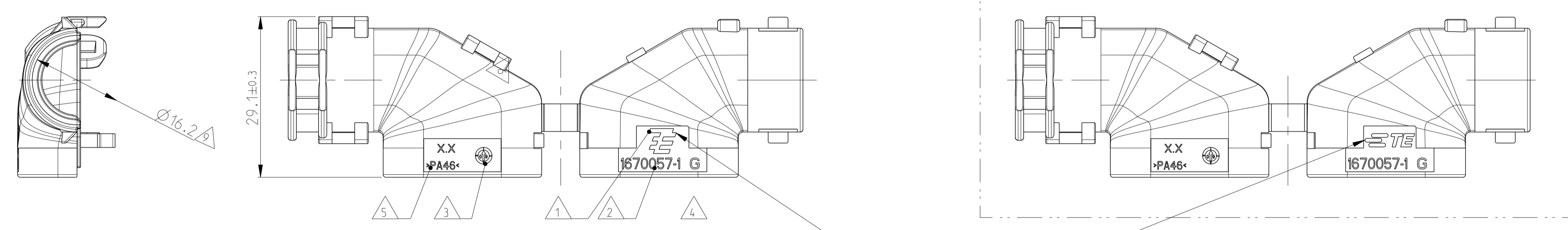

TE LOGO RELATED TO MOLDING TOOL  
 TE Logo abhaengig von Spritzgusswerkzeug

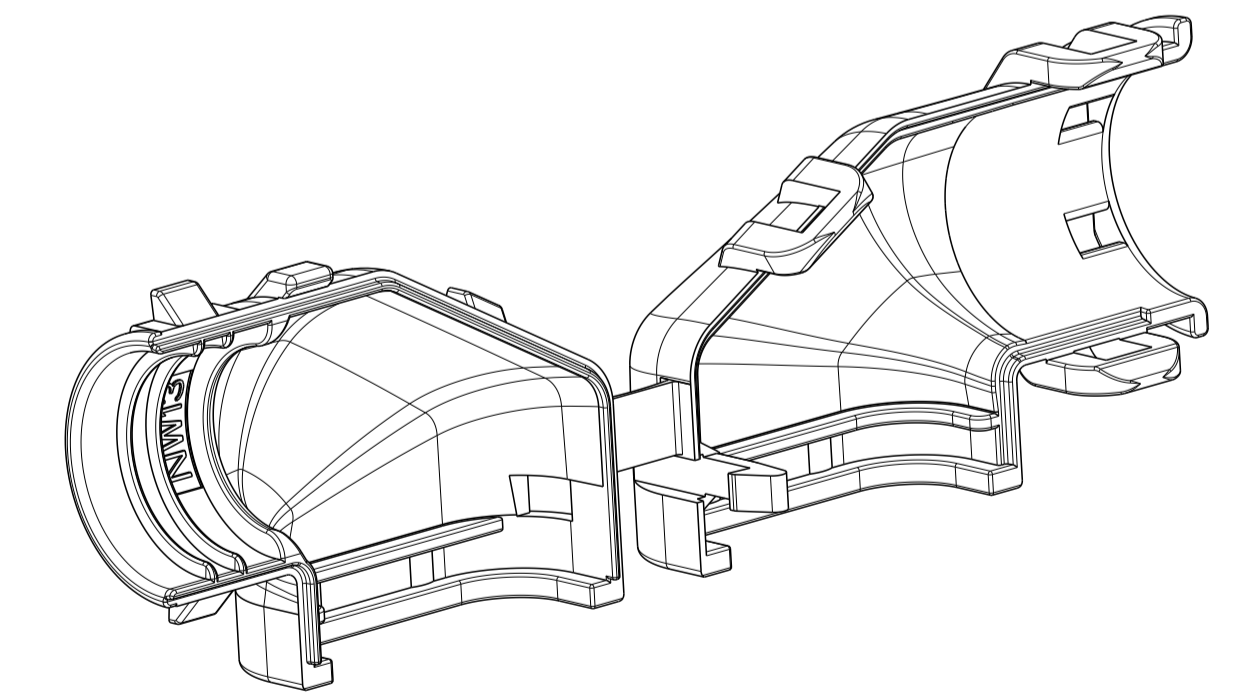
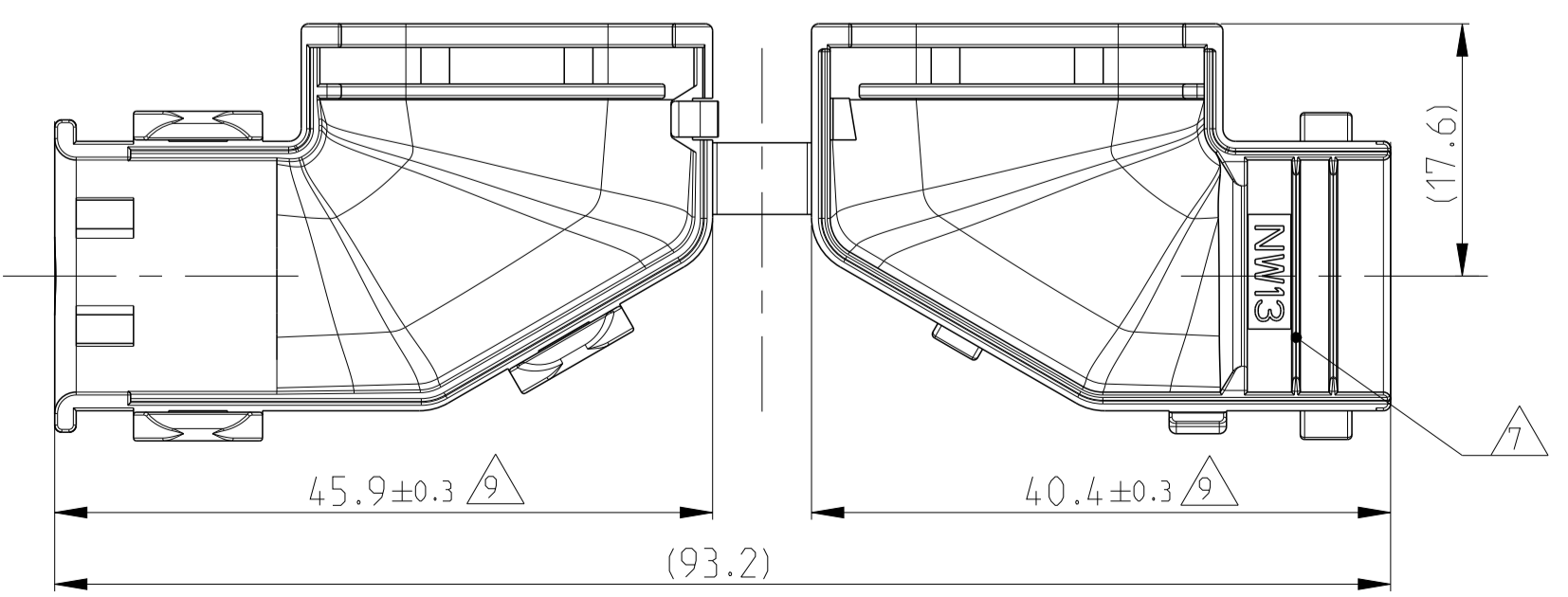
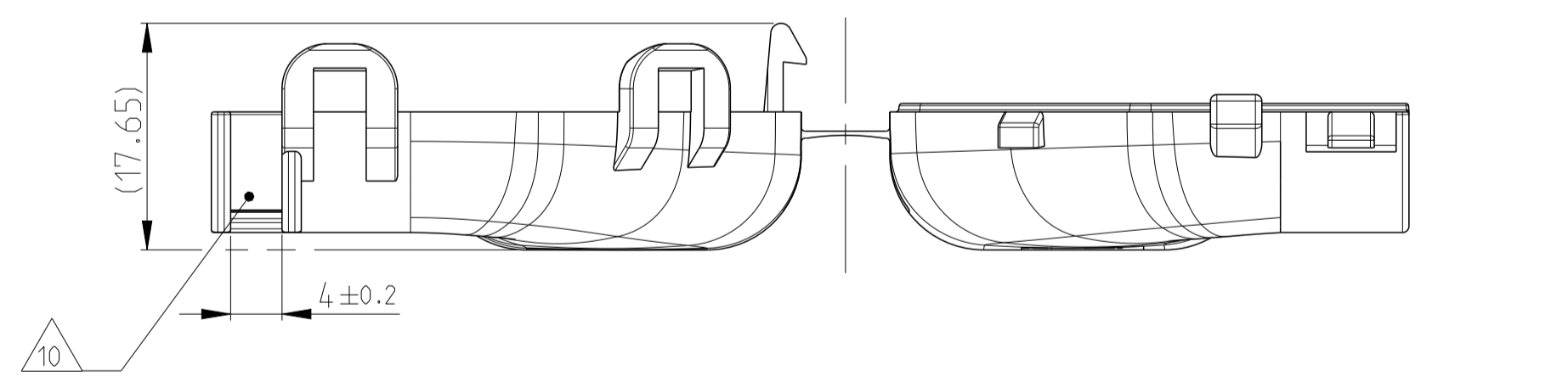

0-1670057-1	G	COVER 90° Kappe 90°	1
TE ORDER-NO. TE Bestell-Nr.	REV.	DESCRIPTION Beschreibung	ITEM

THIS DRAWING IS A CONTROLLED DOCUMENT.		DMN D.Bischoff	26OCT2006	TE Connectivity
DIMENSIONS: mm		CHK J.Grandzow	31OCT2006	
TOLERANCES UNLESS OTHERWISE SPECIFIED:		APVD C. Oberwein	02NOV2006	
0 PLC ±0.10 1 PLC ±0.15 2 PLC ±0.20 3 PLC ±0.25 4 PLC ±0.30 ANGLES ±0.5°		NAME COVER 90 DEG. Kappe 90 Grad HDSCS - GROUP C	PRODUCT SPEC 108-94.020 APPLICATION SPEC 116-18756	
MATERIAL PA66/6 (V-0)	FINISH BLACK schwarz	WEIGHT 5.2g	SIZE A1	RESTRICTED TO
CUSTOMER DRAWING		SCALE 5:1	SHEET 1 OF 1	REV. G2

## Looking for pricing, stock, or lifecycle information?

Click below to explore more details on WIN SOURCE:

 [View 1670057-1 on WIN SOURCE](#)

 [TE Connectivity](#) Information

## Optimize Your Supply Chain with WIN SOURCE Solutions

-  Global Sourcing Solution
-  Obsolete Management
-  Cost Control Management
-  Shortage Management
-  Alternative Solution
-  Excess Inventory Management