



**THE DATASHEET OF  
168102K100A-F**



# Type 168/185 Metallized Polyester Radial Lead Capacitors

## Radial Box Metallized Polyester Capacitors for Automatic Insertion

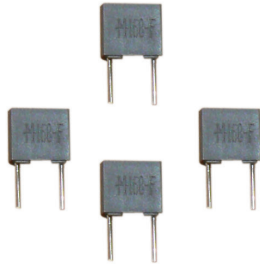

The Type 168/185 series radial lead metallized polyester box capacitors are available in bulk (Type 168) or on ammo pack or tape and reel (Type 185). These capacitors are constructed in rugged rectangular plastic cases and all come with 5.0 mm (0.197") lead spacing. They are good for general purpose applications such as bypass, decoupling, energy storage/discharge and arc suppression.

### Highlights

- Case and epoxy fill meets UL94V-0
- 5.0 mm (0.197") lead spacing
- Bulk, tape and reel or ammo pack
- Non-inductively wound
- Non-polar
- Low leakage
- Lead material: Tinned copper wire

### Specifications

Capacitance Range	0.001 $\mu$ F to 1.0 $\mu$ F																								
Capacitance Tolerance	$\pm$ 5%, $\pm$ 10%, $\pm$ 20%																								
Rated Voltage	50 to 400 Vdc																								
Operating Temperature Range	-55 $^{\circ}$ C to +125 $^{\circ}$ C (with 50% Vdc derating >85 $^{\circ}$ C)																								
Dielectric Withstand Voltage	1.6 x rated voltage for 2 s @ +25 $^{\circ}$ C $\pm$ 5 $^{\circ}$ C																								
Dissipation Factor @ 120 Hz, +25 $^{\circ}$ C	$\text{tg}\delta \times 10^{-4}$ at +25 $^{\circ}$ C $\pm$ 5 $^{\circ}$ C <table border="1" style="margin-left: 20px;"> <thead> <tr> <th>kHz</th> <th>C <math>\leq</math> 0.1 <math>\mu</math>F</th> <th>C &gt; 0.1 <math>\mu</math>F</th> </tr> </thead> <tbody> <tr> <td>1</td> <td><math>\leq</math>100</td> <td><math>\leq</math>100</td> </tr> <tr> <td>10</td> <td><math>\leq</math>150</td> <td><math>\leq</math>150</td> </tr> <tr> <td>100</td> <td><math>\leq</math>300</td> <td></td> </tr> </tbody> </table>	kHz	C $\leq$ 0.1 $\mu$ F	C > 0.1 $\mu$ F	1	$\leq$ 100	$\leq$ 100	10	$\leq$ 150	$\leq$ 150	100	$\leq$ 300													
kHz	C $\leq$ 0.1 $\mu$ F	C > 0.1 $\mu$ F																							
1	$\leq$ 100	$\leq$ 100																							
10	$\leq$ 150	$\leq$ 150																							
100	$\leq$ 300																								
Total Self Inductance (L)	Approximately 7nH																								
Maximum Pulse Rise Time (dv/dt)	<p>If the working voltage (V) is less than the nominal voltage (Vn), the capacitor can work at higher dv/dt. In this case, the maximum value allowed is obtained by multiplying the above value with the ratio Vn/V.</p> <table border="1" style="margin-left: 20px;"> <thead> <tr> <th>Vn</th> <th>Capacitance</th> <th>V/<math>\mu</math>s</th> </tr> </thead> <tbody> <tr> <td>50</td> <td></td> <td>4</td> </tr> <tr> <td>63</td> <td></td> <td>8</td> </tr> <tr> <td>100</td> <td>C &gt; .0068 <math>\mu</math>F</td> <td>10</td> </tr> <tr> <td></td> <td>.0033 <math>\mu</math>F &lt; C &lt; .0068 <math>\mu</math>F</td> <td>15</td> </tr> <tr> <td></td> <td>C <math>\leq</math> .0033 <math>\mu</math>F</td> <td>30</td> </tr> <tr> <td>250</td> <td></td> <td>44</td> </tr> <tr> <td>400</td> <td></td> <td>100</td> </tr> </tbody> </table>	Vn	Capacitance	V/ $\mu$ s	50		4	63		8	100	C > .0068 $\mu$ F	10		.0033 $\mu$ F < C < .0068 $\mu$ F	15		C $\leq$ .0033 $\mu$ F	30	250		44	400		100
Vn	Capacitance	V/ $\mu$ s																							
50		4																							
63		8																							
100	C > .0068 $\mu$ F	10																							
	.0033 $\mu$ F < C < .0068 $\mu$ F	15																							
	C $\leq$ .0033 $\mu$ F	30																							
250		44																							
400		100																							
Long Term Stability (after two years)	Capacitance change $\Delta$ C/C $\leq$ $\pm$ 3% under standard environmental conditions																								
<a href="#">Regulatory Information</a>																									

# Type 168/185 Metallized Polyester Radial Lead Capacitors

## Capacitor Outline Drawing

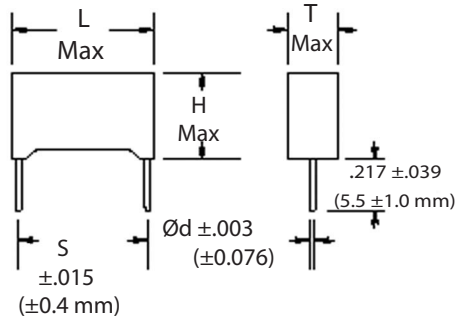

<b>Soldering</b>	
<b>Test Conditions</b>	
Soldering Temperature: 260 °C ± 5 °C	
Soldering Duration: 10 sec ± 1 sec	
<b>Performance</b>	
Capacitance Change $\Delta C/C$ : $\leq \pm 2\%$	
DF Change $\Delta tg\delta$ : $\leq 30 \times 10^{-4}$ at 10 kHz	
Insulation Resistance: $\geq$ limit value	

## Test Method and Performance

<b>Insulation Resistance</b>	
<b>Test Conditions</b>	
Temperature: 25 °C ± 5 °C	
Voltage Charge Time: 1 minute	
Voltage Charge: 10 Vdc for $V_n < 100$ Vdc 100 Vdc for $V_n \geq 100$ Vdc	
<b>Performance</b>	
For $V_n > 100$ Vdc: $C \leq 0.33 \mu F, \geq 15,000 M\Omega$ $C > 0.33 \mu F, \geq 5,000 S$	
For $V_n \leq 100$ Vdc: $C \leq 0.33 \mu F, 30,000 M\Omega$ $C > 0.33 \mu F, \geq 10,000 S$	
<b>Damp Heat Test</b>	
<b>Test Conditions</b>	
Temperature: +40 °C	
Relative Humidity: 95%	
Test Duration: 21 days	
<b>Performance</b>	
Capacitance Change $\Delta C/C$ : $\pm 5\%$	
DF Change $\Delta tg\delta$ : $\leq 0.005$ (10 KHz)	
Insulation Resistance: $\geq 50\%$ of limit value	
<b>Life Test</b>	
<b>Test Conditions</b>	
REF	
Temperature: +85 °C	
Test Duration: 2000 hrs	
Voltage Applied: 1.25 x $V_n$	
<b>Performance</b>	
Capacitance Change $\Delta C/C$ : $\leq \pm 2\%$	
DF Change $\Delta tg\delta$ : $\leq 30 \times 10^{-4}$ at 10 kHz	
Insulation Resistance: $\geq 50\%$ of limit value	

## Ratings

Catalog Part Number	Tape & Reel Ammo Pack	Cap ( $\mu F$ )	Inches					Millimeters				
			L	T	H	S	$\phi d$	L	T	H	S	$\phi d$
<b>50 Vdc</b>												
168104*50A-F	185104*50#A>-F	0.10	0.283	0.098	0.256	0.197	0.020	7.2	2.5	6.5	5.0	0.5
168154*50A-F	185154*50#A>-F	0.15	0.283	0.098	0.256	0.197	0.020	7.2	2.5	6.5	5.0	0.5
168224*50C-F	185224*50#C>-F	0.22	0.283	0.138	0.295	0.197	0.020	7.2	3.5	7.5	5.0	0.5
168334*50C-F	185334*50#C>-F	0.33	0.283	0.138	0.295	0.197	0.020	7.2	3.5	7.5	5.0	0.5
168474*50H-F	185474*50#H>-F	0.47	0.283	0.138	0.295	0.197	0.020	7.2	3.5	7.5	5.0	0.5
168684*50F-F	185684*50#F>-F	0.68	0.283	0.236	0.433	0.197	0.024	7.2	6.0	11.0	5.0	0.6
168824*50G-F	185824*50#G>-F	0.82	0.283	0.236	0.433	0.197	0.024	7.2	6.0	11.0	5.0	0.6
168105*50G-F	185105*50#G>-F	1.00	0.283	0.236	0.433	0.197	0.024	7.2	6.0	11.0	5.0	0.6
<b>63 Vdc</b>												
168473*63A-F	185473*63#A>-F	0.047	0.283	0.098	0.256	0.197	0.020	7.2	2.5	6.5	5.0	0.5
168563*63A-F	185563*63#A>-F	0.056	0.283	0.098	0.256	0.197	0.020	7.2	2.5	6.5	5.0	0.5
168683*63A-F	185683*63#A>-F	0.068	0.283	0.098	0.256	0.197	0.020	7.2	2.5	6.5	5.0	0.5
168823*63A-F	185823*63#A>-F	0.082	0.283	0.098	0.256	0.197	0.020	7.2	2.5	6.5	5.0	0.5
168104*63A-F	185104*63#A>-F	0.10	0.283	0.098	0.256	0.197	0.020	7.2	2.5	6.5	5.0	0.5
168154*63C-F	185154*63#C>-F	0.15	0.283	0.138	0.295	0.197	0.020	7.2	3.5	7.5	5.0	0.5
168184*63C-F	185184*63#C>-F	0.18	0.283	0.138	0.295	0.197	0.020	7.2	3.5	7.5	5.0	0.5
168224*63C-F	185224*63#C>-F	0.22	0.283	0.138	0.295	0.197	0.020	7.2	3.5	7.5	5.0	0.5
168274*63C-F	185274*63#C>-F	0.27	0.283	0.098	0.256	0.197	0.020	7.2	2.5	6.5	5.0	0.5
168334*63H-F	185334*63#H>-F	0.33	0.283	0.138	0.295	0.197	0.020	7.2	3.5	7.5	5.0	0.5
168474*63H-F	185474*63#H>-F	0.47	0.283	0.138	0.295	0.197	0.020	7.2	3.5	7.5	5.0	0.5
168684*63F-F	185684*63#F>-F	0.68	0.283	0.177	0.374	0.197	0.024	7.2	4.5	9.5	5.0	0.6
168105*63G-F	185105*63#G>-F	1.00	0.283	0.236	0.433	0.197	0.024	7.2	6.0	11.0	5.0	0.6

\* Indicates capacitance tolerance: J =  $\pm 5\%$ , K =  $\pm 10\%$ , M =  $\pm 20\%$

# Indicates packaging type: R = Tape and Reel, A = Ammo Pack

> Indicates tooling code: A = 16.5 mm, B = 18.5 mm (See H dimension in taping specifications)

# Type 168/185 Metallized Polyester Radial Lead Capacitors

Catalog Part Number	Tape & Reel Ammo Pack	Cap (µF)	Inches					Millimeters				
			L	T	H	S	Ød	L	T	H	S	Ød
<b>100 Vdc</b>												
168102*100A-F	185102*100#A>-F	0.0010	0.283	0.098	0.256	0.197	0.020	7.2	2.5	6.5	5.0	0.5
168152*100A-F	185152*100#A>-F	0.0015	0.283	0.098	0.256	0.197	0.020	7.2	2.5	6.5	5.0	0.5
168222*100A-F	185222*100#A>-F	0.0022	0.283	0.098	0.256	0.197	0.020	7.2	2.5	6.5	5.0	0.5
168272*100A-F	185272*100#A>-F	0.0027	0.283	0.098	0.256	0.197	0.020	7.2	2.5	6.5	5.0	0.5
168332*100A-F	185332*100#A>-F	0.0033	0.283	0.098	0.256	0.197	0.020	7.2	2.5	6.5	5.0	0.5
168392*100A-F	185392*100#A>-F	0.0039	0.283	0.098	0.256	0.197	0.020	7.2	2.5	6.5	5.0	0.5
168472*100A-F	185472*100#A>-F	0.0047	0.283	0.098	0.256	0.197	0.020	7.2	2.5	6.5	5.0	0.5
168562*100A-F	185562*100#A>-F	0.0056	0.283	0.098	0.256	0.197	0.020	7.2	2.5	6.5	5.0	0.5
168682*100A-F	185682*100#A>-F	0.0068	0.283	0.098	0.256	0.197	0.020	7.2	2.5	6.5	5.0	0.5
168822*100A-F	185822*100#A>-F	0.0082	0.283	0.098	0.256	0.197	0.020	7.2	2.5	6.5	5.0	0.5
168103*100A-F	185103*100#A>-F	0.010	0.283	0.098	0.256	0.197	0.020	7.2	2.5	6.5	5.0	0.5
168153*100A-F	185153*100#A>-F	0.015	0.283	0.098	0.256	0.197	0.020	7.2	2.5	6.5	5.0	0.5
168183*100A-F	185183*100#A>-F	0.018	0.283	0.098	0.256	0.197	0.020	7.2	2.5	6.5	5.0	0.5
168223*100A-F	185223*100#A>-F	0.022	0.283	0.098	0.256	0.197	0.020	7.2	2.5	6.5	5.0	0.5
168273*100A-F	185273*100#A>-F	0.027	0.283	0.098	0.256	0.197	0.020	7.2	2.5	6.5	5.0	0.5
168333*100C-F	185333*100#C>-F	0.033	0.283	0.098	0.256	0.197	0.020	7.2	2.5	6.5	5.0	0.5
168393*100C-F	185393*100#C>-F	0.039	0.283	0.098	0.256	0.197	0.020	7.2	2.5	6.5	5.0	0.5
168473*100C-F	185473*100#C>-F	0.047	0.283	0.098	0.256	0.197	0.020	7.2	2.5	6.5	5.0	0.5
168683*100H-F	185683*100#H>-F	0.068	0.283	0.098	0.256	0.197	0.020	7.2	2.5	6.5	5.0	0.5
168104*100H-F	185104*100#H>-F	0.10	0.283	0.098	0.256	0.197	0.020	7.2	2.5	6.5	5.0	0.5
168154*100F-F	185154*100#F>-F	0.15	0.283	0.177	0.374	0.197	0.024	7.2	4.5	9.5	5.0	0.6
168224*100G-F	185224*100#G>-F	0.22	0.283	0.197	0.394	0.197	0.024	7.2	5.0	10.0	5.0	0.6
<b>250 Vdc</b>												
168332*250A-F	185332*250#A>-F	0.0033	0.283	0.098	0.256	0.197	0.020	7.2	2.5	6.5	5.0	0.5
168472*250A-F	185472*250#A>-F	0.0047	0.283	0.098	0.256	0.197	0.020	7.2	2.5	6.5	5.0	0.5
168682*250A-F	185682*250#A>-F	0.0068	0.283	0.098	0.256	0.197	0.020	7.2	2.5	6.5	5.0	0.5
168103*250A-F	185103*250#A>-F	0.010	0.283	0.098	0.256	0.197	0.020	7.2	2.5	6.5	5.0	0.5
168153*250A-F	185153*250#A>-F	0.015	0.283	0.098	0.256	0.197	0.020	7.2	2.5	6.5	5.0	0.5
168223*250C-F	185223*250#C>-F	0.022	0.283	0.138	0.295	0.197	0.020	7.2	3.5	7.5	5.0	0.5
168333*250C-F	185333*250#C>-F	0.033	0.283	0.138	0.295	0.197	0.020	7.2	3.5	7.5	5.0	0.5
168473*250F-F	185473*250#F>-F	0.047	0.283	0.177	0.374	0.197	0.024	7.2	4.5	9.5	5.0	0.6
168683*250F-F	185683*250#F>-F	0.068	0.283	0.177	0.374	0.197	0.024	7.2	4.5	9.5	5.0	0.6
168104*250G-F	185104*250#G>-F	0.100	0.283	0.197	0.394	0.197	0.024	7.2	5.0	10	5.0	0.6
<b>400 Vdc</b>												
168102*400A-F	185102*400#A>-F	0.001	0.283	0.098	0.256	0.197	0.020	7.2	2.5	6.5	5.0	0.5
168152*400A-F	185152*400#A>-F	0.0015	0.283	0.098	0.256	0.197	0.020	7.2	2.5	6.5	5.0	0.5
168222*400A-F	185222*400#A>-F	0.0022	0.283	0.098	0.256	0.197	0.020	7.2	2.5	6.5	5.0	0.5
168332*400C-F	185332*400#C>-F	0.0033	0.283	0.098	0.256	0.197	0.020	7.2	2.5	6.5	5.0	0.5
168472*400C-F	185472*400#C>-F	0.0047	0.283	0.098	0.256	0.197	0.020	7.2	2.5	6.5	5.0	0.5
168682*400C-F	185682*400#C>-F	0.0068	0.283	0.138	0.295	0.197	0.020	7.2	3.5	7.5	5.0	0.5
168103*400F-F	185103*400#F>-F	0.010	0.283	0.138	0.295	0.197	0.020	7.2	3.5	7.5	5.0	0.5
168153*400F-F	185153*400#F>-F	0.015	0.283	0.177	0.374	0.197	0.024	7.2	4.5	9.5	5.0	0.6
168223*400G-F	185223*400#G>-F	0.022	0.283	0.197	0.394	0.197	0.024	7.2	5.0	10	5.0	0.6

\* Indicates capacitance tolerance: J = ±5%, K = ±10%, M = ±20%

# Indicates packaging type: R = Tape and Reel, A = Ammo Pack

> Indicates tooling code: A = 16.5 mm, B = 18.5 mm (See H dimension in taping specification)

# Type 168/185 Metallized Polyester Radial Lead Capacitors

## Tape Specification - 5.0 mm Lead Spacing

### Standard EIA-468-B

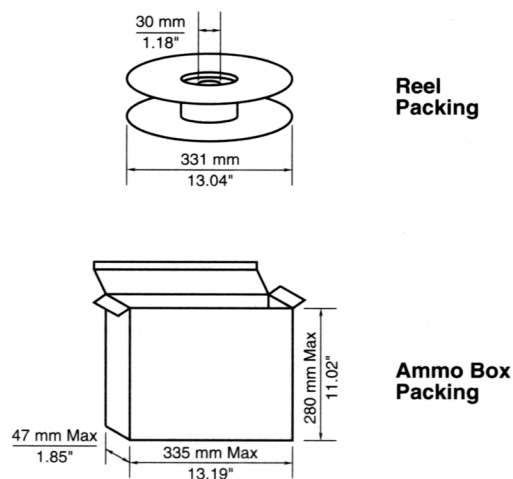
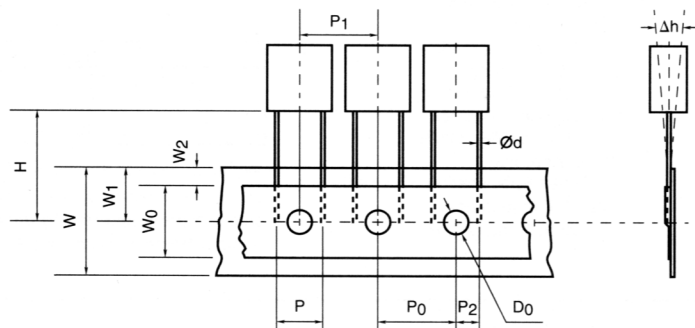

Item	Code	Millimeters	Inches
Lead-to-Lead Distance	P	5.0 <sup>+0.6 -0.2</sup>	.197 <sup>+0.024 -0.040</sup>
Feed Hole Pitch	P <sub>0</sub>	12.7 <sup>±0.3</sup>	.5 <sup>±0.12</sup>
Pitch of Component	P <sub>1</sub>	12.7 <sup>±1.0</sup>	.5 <sup>±0.39</sup>
Hole Center to Lead	P <sub>2</sub>	2.54 <sup>±0.7</sup>	.100 <sup>±0.28</sup>
Feed Hole Center to Component Center	P <sub>3</sub>	6.35 <sup>±1.3</sup>	.250 <sup>±0.51</sup>
Component Alignment, F-R	Δh	0 <sup>±2.0</sup>	0 <sup>±0.79</sup>
Tape Width	W	18 <sup>+1.0 -0.1</sup>	.709 <sup>+0.039 -0.004</sup>
Hold-down Tape Width	W <sub>0</sub>	6.0 min	.236 min
Hole Position	W <sub>1</sub>	9.0 <sup>+0.75 -0.05</sup>	.355 <sup>+0.030 -0.001</sup>
Hold-down Tape Position	W <sub>2</sub>	3.0 Max	.118 Max
Height of Component from Tape Center	H	>	>
Feed Hole Diameter	D <sub>0</sub>	4.0 <sup>±0.3</sup>	.157 <sup>±0.12</sup>

Case Thickness T	Quantity Reeled	Quantity Ammo Pack
2.5	2500	2000
3.5	1800	1500
4.5	1400	1300
5	1200	1000
6	1000	800

> The H dimension depends on the insertion equipment used. Specify the proper tooling code as indicated below.

Tooling Code	H Dimensions	
	Millimeters	Inches
A	16.5 <sup>±0.75</sup>	.679 <sup>±0.030</sup>
B	18.5 <sup>±0.75</sup>	.728 <sup>±0.030</sup>

## Part Numbering System for Auto Insertion

168/185	104	K	100	(#)	H	(>)	-F
Series	Capacitance	Tolerance	Voltage	Packaging Type	Internal Code	*Tooling Code	RoHS Compliant Designation
185	102 = .001 μF	J = ±5%	50 = 50 Vdc	A = Ammo	Letter	A	
	103 = .01 μF	K = ±10%	63 = 63 Vdc	R = Tape & Reel		B	
	104 = .1 μF	M = ±20%	100 = 100 Vdc	Blank = Bulk		Blank = Bulk	
	105 = 1.0 μF		250 = 250 Vdc				
			400 = 400 Vdc				

\* Tooling code (>) depends on the users insertion equipment requirements. See table for available options.

## Type 168/185 Metallized Polyester Radial Lead Capacitors

---

**Notice and Disclaimer:** All product drawings, descriptions, specifications, statements, information and data (collectively, the "Information") in this datasheet or other publication are subject to change. The customer is responsible for checking, confirming and verifying the extent to which the Information contained in this datasheet or other publication is applicable to an order at the time the order is placed. All Information given herein is believed to be accurate and reliable, but it is presented without any guarantee, warranty, representation or responsibility of any kind, expressed or implied. Statements of suitability for certain applications are based on the knowledge that the Cornell Dubilier company providing such statements ("Cornell Dubilier") has of operating conditions that such Cornell Dubilier company regards as typical for such applications, but are not intended to constitute any guarantee, warranty or representation regarding any such matter – and Cornell Dubilier specifically and expressly disclaims any guarantee, warranty or representation concerning the suitability for a specific customer application, use, storage, transportation, or operating environment. The Information is intended for use only by customers who have the requisite experience and capability to determine the correct products for their application. Any technical advice inferred from this Information or otherwise provided by Cornell Dubilier with reference to the use of any Cornell Dubilier products is given gratis (unless otherwise specified by Cornell Dubilier), and Cornell Dubilier assumes no obligation or liability for the advice given or results obtained. Although Cornell Dubilier strives to apply the most stringent quality and safety standards regarding the design and manufacturing of its products, in light of the current state of the art, isolated component failures may still occur. Accordingly, customer applications which require a high degree of reliability or safety should employ suitable designs or other safeguards (such as installation of protective circuitry or redundancies or other appropriate protective measures) in order to ensure that the failure of an electrical component does not result in a risk of personal injury or property damage. Although all product-related warnings, cautions and notes must be observed, the customer should not assume that all safety measures are indicated in such warnings, cautions and notes, or that other safety measures may not be required.

## Looking for pricing, stock, or lifecycle information?

Click below to explore more details on WIN SOURCE:

- [View 168102K100A-F on WIN SOURCE](#)
- [Cornell Dubilier Electronics \(CDE\) Information](#)

## Optimize Your Supply Chain with WIN SOURCE Solutions

- ✓ Global Sourcing Solution
- ✓ Obsolete Management
- ✓ Cost Control Management
- ✓ Shortage Management
- ✓ Alternative Solution
- ✓ Excess Inventory Management