



**THE DATASHEET OF
BQ500215RGCT**



bq500215 WPC v1.2 Compliant Wireless Power Transmitter Manager With Proprietary 10-W Power Delivery

1 Features

- Qi-Certified WPC v1.2 Solution for 5-W Operation and Proprietary 10-W Charging Capability With TI bq51025 Wireless Power Receiver
 - Proprietary Authentication Protocol With TI bq51025 Receiver
 - Faster Charging Time
 - Compatible With Standard 5-W WPC Receivers
- 12-V Input, Fixed Frequency, Rail Voltage Control Architecture
- Conforms to Wireless Power Consortium (WPC) A29 Transmitter Type Specification
- Enhanced Foreign Object Detection (FOD) Implementation With FOD Ping that Detects Metal Objects Prior to Power Transfer
- Low Standby Power During Idle and 'Charge Complete'
- 10 Configurable LED Modes Indicate Charging State and Fault Status
- Digital Demodulation Reduces Components and Simplifies Circuitry

2 Applications

- WPC v1.2 Wireless Chargers:
 - Qi-Certified Smart Phones, Tablets, and Other Handhelds
 - Point-of-Sale Devices
 - Custom Wireless Power Applications

Simplified Diagram

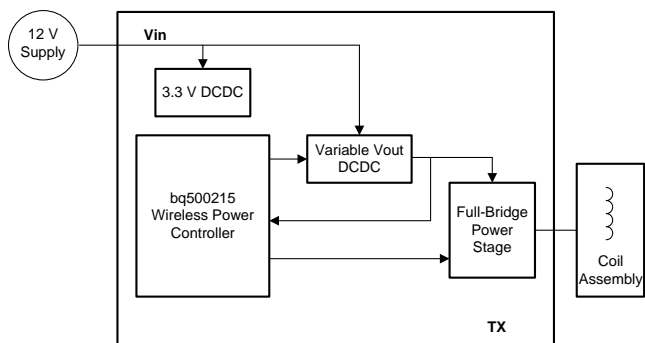

- See www.ti.com/wirelesspower for More Information on TI's Wireless Charging Solutions

3 Description

The bq500215 is a dedicated wireless power digital controller that integrates the logic functions required to control wireless power transfer to a single WPC-compliant receiver. The bq500215 complies with the WPC v1.2 standard for power delivery up to 5 W and uses a proprietary bidirectional communication protocol to allow charging at up to 10 W with the bq51025 wireless power receiver. The bq500215 is an intelligent device that periodically pings the surrounding environment for available devices to be powered, detects if a foreign metal object is present on the charging pad, monitors all communication from the device being wirelessly powered, and adjusts power applied to the transmitter coil per feedback received from the powered device. The bq500215 also manages the fault conditions associated with the power transfer and controls the operating mode status indicator. The bq500215 uses a rail voltage control scheme instead of the traditional frequency control to adjust the amount of power delivered to the receiver.

Device Information⁽¹⁾

PART NUMBER	PACKAGE	BODY SIZE (NOM)
bq500215	VQFN (64)	9.00 mm x 9.00 mm

(1) For all available packages, see the orderable addendum at the end of the data sheet.

Efficiency vs System Output Power With bq51025 Receiver

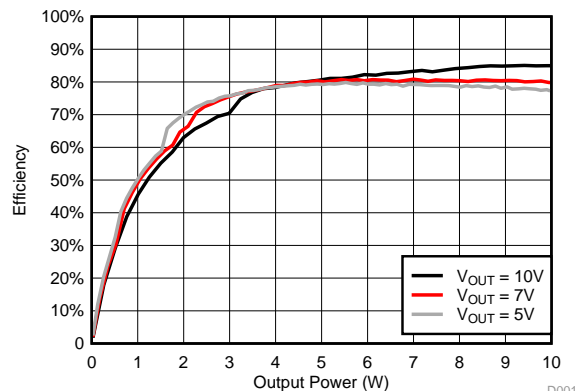

Table of Contents

1 Features	1	7.4 Device Functional Modes.....	15
2 Applications	1	8 Application and Implementation	18
3 Description	1	8.1 Application Information.....	18
4 Revision History	2	8.2 Typical Application	18
5 Pin Configuration and Functions	3	9 Power Supply Recommendations	21
6 Specifications	6	10 Layout	21
6.1 Absolute Maximum Ratings	6	10.1 Layout Guidelines	21
6.2 ESD Ratings.....	6	10.2 Layout Example	21
6.3 Recommended Operating Conditions.....	6	11 Device and Documentation Support	27
6.4 Thermal Information	6	11.1 Device Support.....	27
6.5 Electrical Characteristics.....	7	11.2 Receiving Notification of Documentation Updates	27
6.6 Typical Characteristics	8	11.3 Community Resources.....	27
7 Detailed Description	9	11.4 Trademarks	27
7.1 Overview	9	11.5 Electrostatic Discharge Caution.....	27
7.2 Functional Block Diagram	9	11.6 Glossary	27
7.3 Feature Description.....	10	12 Mechanical, Packaging, and Orderable Information	27

4 Revision History

Changes from Revision A (November 2014) to Revision B	Page
• Changed From: WPC v1.1 To: WPC v1.2 throughout the document	1
• Changed pin 65 to Thermal Pad in the <i>Pin Functions</i> table.....	5
• Moved the Storage temperature range to the <i>Absolute Maximum Ratings</i> table	6
• Changed Handling Ratings To: <i>ESD Ratings</i>	6

Changes from Original (October 2014) to Revision A	Page
• Updated device status to production data.....	1

5 Pin Configuration and Functions

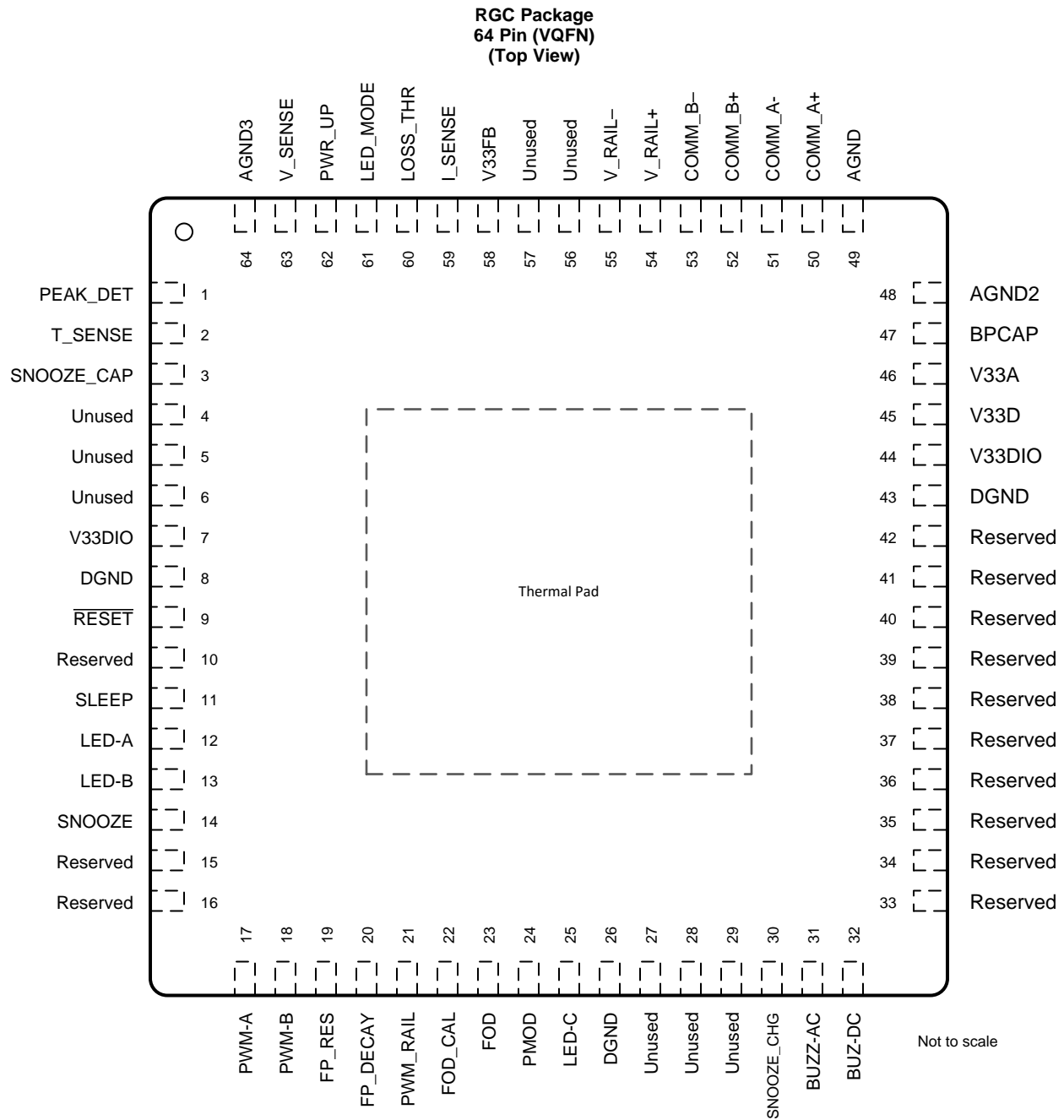

Pin Functions

PIN		I/O	DESCRIPTION
NAME	NO.		
PEAK_DET	1	I	Input from peak detect circuit
T_SENSE	2	I	Sensor input. Device shuts down when below 1 V. If not used, keep above 1 V by simply connecting to 3.3-V supply
SNOOZE_CAP	3	I	Indicates wake from SNOOZE (short) or SLEEP (long)
Unused	4	—	This pin can be either connected to GND or left open. Connecting to GND can improve layout grounding.
Unused	5	—	This pin can be either connected to GND or left open. Connecting to GND can improve layout grounding.
Unused	6	—	This pin can be either connected to GND or left open. Connecting to GND can improve layout grounding.
V33DIO	7	—	3.3-V IO power supply
DGND	8	—	GND
RESET	9	I	Device reset. Use 10- to 100-k Ω pullup resistor to 3.3-V supply
Reserved	10	—	Reserved, leave this pin open
SLEEP	11	O	Force SLEEP (5 s low power). Connected to 5-s interval circuit
LED-A	12	O	Connect to an LED with a 470- Ω resistor for status indication.
LED-B	13	O	Connect to an LED with a 470- Ω resistor for status indication.
SNOOZE	14	O	Force SNOOZE (500 ms low power)
Reserved	15	I	Reserved, connect to GND
Reserved	16	I/O	Reserved, connect to GND
PWM-A	17	O	PWM output A, controls one half of the full bridge in a phase-shifted full bridge. Switching dead times must be externally generated.
PWM-B	18	O	PWM output B, controls other half of the full bridge in a phase-shifted full bridge. Switching dead times must be externally generated.
FP_RES	19	O	Output to select the FOD ping calibration threshold
FP_DECAY	20	O	Output to select the FOD ping calibration threshold
PWM_RAIL	21	O	PWM control signal for full bridge rail voltage
FOD_CAL	22	O	Output to select the FOD calibration
FOD	23	O	Output to select the foreign object detection (FOD) threshold
PMOD	24	O	Output to select the PMOD threshold
LED-C	25	O	Connect to an LED with a 470- Ω resistor for status indication.
DGND	26	—	GND
Unused	27	—	This pin can be either connected to GND or left open. Connecting to GND can improve layout grounding.
Unused	28	—	This pin can be either connected to GND or left open. Connecting to GND can improve layout grounding.
Unused	29	—	This pin can be either connected to GND or left open. Connecting to GND can improve layout grounding.
SNOOZE_CH G	30	O	SNOOZE capacitor charging source. Connected to capacitor
BUZZ-AC	31	O	AC buzzer output. A 400-ms, 4-kHz AC pulse train when charging begins
BUZ-DC	32	O	DC buzzer output. A 400-ms DC pulse when charging begins. This could also be connected to an LED with a 470- Ω resistor.
Reserved	33	—	Reserved, leave this pin open
Reserved	34	—	Reserved, leave this pin open
Reserved	35	—	Reserved, leave this pin open
Reserved	36	—	Reserved, leave this pin open
Reserved	37	—	Reserved, leave this pin open
Reserved	38	—	Reserved, leave this pin open
Reserved	39	—	Reserved, leave this pin open
Reserved	40	—	Reserved, connect to 10-k Ω resistor to GND
Reserved	41	—	Reserved, leave this pin open
Reserved	42	—	Reserved, leave this pin open
DGND	43	—	GND

Pin Functions (continued)

PIN		I/O	DESCRIPTION
NAME	NO.		
V33DIO	44	—	3.3-V IO power supply
V33D	45	—	Digital core 3.3-V supply. Be sure to decouple with bypass capacitors as close to the part as possible.
V33A	46	—	Analog 3.3-V supply. This pin can be derived from V33D supply, decouple with 22-Ω resistor and additional bypass capacitors.
BPCAP	47	—	Connect to 1uF bypass capacitors to 3.3V supply and GND
AGND2	48	—	GND
AGND	49	—	GND
COMM_A+	50	I	Digital demodulation non-inverting input A. Connect parallel to input B+
COMM_A-	51	I	Digital demodulation inverting input A. Connect parallel to input B-
COMM_B+	52	I	Digital demodulation non-inverting input B. Connect parallel to input A+
COMM_B-	53	I	Digital demodulation inverting input B. Connect parallel to input A-
V_RAIL+	54	I	Feedback for full bridge rail voltage control +
V_RAIL-	55	I	Feedback for full bridge rail voltage control -
Unused	56	—	This pin can be either connected to GND or left open. Connecting to GND can improve layout grounding.
Unused	57	—	This pin can be either connected to GND or left open. Connecting to GND can improve layout grounding.
V33FB	58	I	Reserved, leave this pin open
I_SENSE	59	I	Full bridge input current sense
LOSS_THR	60	I	Input for FOD/PMOD calibration and configuration
LED_MODE	61	I	LED mode select
PWR_UP	62	I	First power-up indicator (pull high if unused)
V_SENSE	63	I	Transmitter rail voltage sense
AGND3	64	—	GND
Thermal Pad		—	Flood with copper GND plane and stitch vias to PCB internal GND plane.

6 Specifications

6.1 Absolute Maximum Ratings⁽¹⁾

over operating free-air temperature (unless otherwise noted)

	MIN	MAX	UNIT
Voltage applied at V33D to DGND	-0.3	3.6	V
Voltage applied at V33A to AGND	-0.3	3.6	
Voltage applied to any pin ⁽²⁾	-0.3	3.6	
Storage temperature range, T _{stg}	-40	150	°C

(1) Stresses beyond those listed under *Absolute Maximum Ratings* may cause permanent damage to the device. These are stress ratings only and functional operation of the device at these or any other conditions beyond those indicated under *Recommended Operating Conditions* is not implied. Exposure to absolute-maximum-rated conditions for extended periods may affect device reliability.

(2) All voltages referenced to GND.

6.2 ESD Ratings

			VALUE	UNIT
V _(ESD)	Electrostatic discharge	Human body model (HBM), per ANSI/ESDA/JEDEC JS-001, all pins ⁽¹⁾	±2000	V
		Charged device model (CDM), per JEDEC specification JESD22-C101, all pins ⁽²⁾	±7500	V

(1) JEDEC document JEP155 states that 500-V HBM allows safe manufacturing with a standard ESD control process.

(2) JEDEC document JEP157 states that 250-V CDM allows safe manufacturing with a standard ESD control process.

6.3 Recommended Operating Conditions

over operating free-air temperature range (unless otherwise noted)

	MIN	NOM	MAX	UNIT
V Supply voltage during operation, V33D, V33A	3.0	3.3	3.6	V
T _A Operating free-air temperature range	-40		85	°C
T _J Junction temperature			125	

6.4 Thermal Information

THERMAL METRIC ⁽¹⁾		bq500215	UNIT
		RGC (64 pins)	
R _{θJA}	Junction-to-ambient thermal resistance	29.5	°C/W
R _{θJC(top)}	Junction-to-case (top) thermal resistance	15.1	
R _{θJB}	Junction-to-board thermal resistance	8.4	
Ψ _{JT}	Junction-to-top characterization parameter	0.2	
Ψ _{JB}	Junction-to-board characterization parameter	8.3	
R _{θJC(bot)}	Junction-to-case (bottom) thermal resistance	1.2	

(1) For more information about traditional and new thermal metrics, see the [Semiconductor and IC Package Thermal Metrics](#) application report.

6.5 Electrical Characteristics

over operating free-air temperature range (unless otherwise noted)

PARAMETER		TEST CONDITIONS	MIN	TYP	MAX	UNIT
SUPPLY CURRENT						
I_{V33A}	Supply current	$V33A = 3.3\text{ V}$		8	15	mA
I_{V33D}		$V33D = 3.3\text{ V}$		44	55	
I_{Total}		$V33D = V33A = 3.3\text{ V}$		52	70	
EXTERNALLY SUPPLIED 3.3 V POWER						
V33D	Digital 3.3-V power	$T_A = 25^\circ\text{C}$	3		3.6	V
V33A	Analog 3.3-V power	$T_A = 25^\circ\text{C}$	3		3.6	
V33Slew	3.3-V slew rate	3.3-V slew rate between 2.3 and 2.9 V, $V33A = V33D$	0.25			V/ms
DIGITAL DEMODULATION INPUTS: COMM_A+, COMM_A-, COMM_B+, COMM_B-						
V_{CM}	Common mode voltage each pin		-0.15		1.631	V
COMM+, COMM-	Modulation voltage digital resolution			1		mV
R_{EA}	Input Impedance	Ground reference	0.5	1.5	3	$M\Omega$
I_{OFFSET}	Input offset current	1-k Ω source impedance	-5		5	μA
ANALOG INPUTS: V_SENSE, I_SENSE, T_SENSE, LED_MODE, LOSS_THR						
V_{ADC_OPEN}	Voltage indicating open pin	LED_MODE, LOSS_THR open	2.37			V
V_{ADC_SHORT}	Voltage indicating pin shorted to GND	LED_MODE, LOSS_THR shorted to ground			0.36	
V_{ADC_RANGE}	Measurement range for voltage monitoring	All analog inputs	0		2.5	
INL	ADC integral nonlinearity		-2.5		2.5	mV
I_{lkg}	Input leakage current	3 V applied to pin			100	nA
R_{IN}	Input impedance	Ground reference	8			$M\Omega$
C_{IN}	Input capacitance				10	pF
DIGITAL INPUTS/OUTPUTS						
V_{OL}	Low-level output voltage	$I_{OL} = 6\text{ mA}$, $V33D = 3\text{ V}$			DGND1 + 0.25	V
V_{OH}	High-level output voltage	$I_{OH} = -6\text{ mA}$, $V33D = 3\text{ V}$		$V33D - 0.6\text{ V}$		
V_{IH}	High-level input voltage	$V33D = 3\text{ V}$		2.1	3.6	
V_{IL}	Low-level input voltage	$V33D = 3.5\text{ V}$			1.4	
$I_{OH(MAX)}$	Output high-source current				4	mA
$I_{OL(MAX)}$	Output low-sink current				4	
SYSTEM PERFORMANCE						
V_{RESET}	Voltage where device comes out of reset	V33D pin			2.4	V
t_{RESET}	Pulse duration needed for reset	\overline{RESET} pin	2			μs
f_{SW}	Switching frequency (wireless power transfer)			130		kHz
t_{detect}	Time to detect presence of device requesting power				0.5	s
PWM RAIL						
f_{SW_RAIL}	Switching frequency			520		kHz

6.6 Typical Characteristics

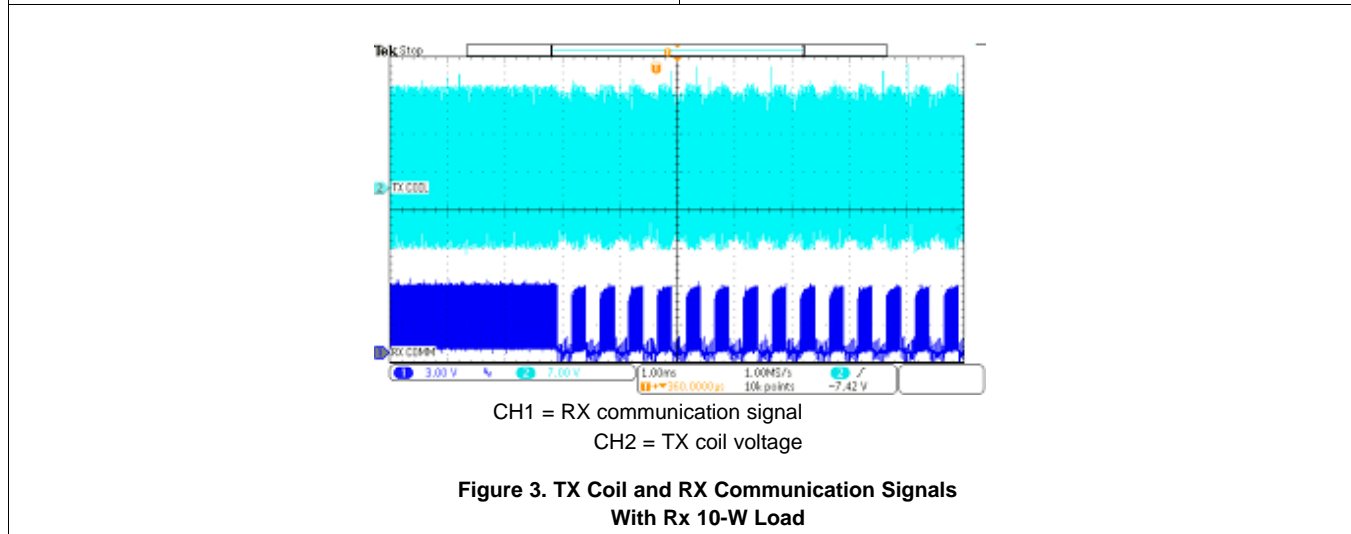
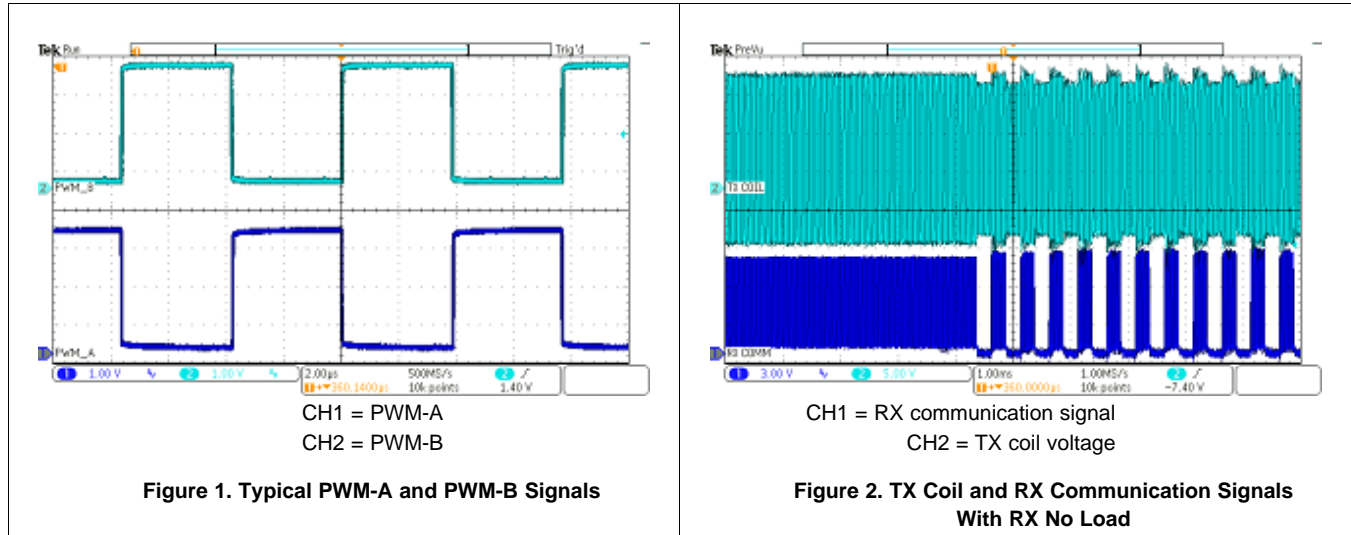

7 Detailed Description

7.1 Overview

The principle of wireless power transfer is simply an open-cored transformer consisting of a transmitter and receiver coils. The transmitter coil and electronics are typically built into a charger pad and the receiver coil and electronics are typically built into a portable device, such as a cell phone. When the receiver coil is positioned on the transmitter coil, magnetic coupling occurs when the transmitter coil is driven. The flux is coupled into the secondary coil, which induces a voltage and current flows. The secondary voltage is rectified, and power can be transferred effectively to a load, wirelessly. Power transfer can be managed through any of the various closed-loop control schemes.

After power is applied and the device comes out of reset, it can automatically begin the process of detecting and powering a receiver. The bq500215 sends a ping to detect the presence of a receiver on the pad. After a receiver is detected, the bq500215 attempts to establish communication and begin power transfer. If the transmitter detects the bq51025 receiver through its proprietary authentication protocol, the transmitter allows 10-W operation. If a standard 5-W WPC compliant receiver is detected, the transmitter allows 5-W of delivered power as per WPC specification. The bq500215 controls a full-bridge power stage to drive the primary coil. It regulates the power being delivered to the receiver by modulating the supply voltage of the power stage while operating at a constant frequency. The full bridge power stage allows for higher power delivery for a given supply voltage.

7.2 Functional Block Diagram

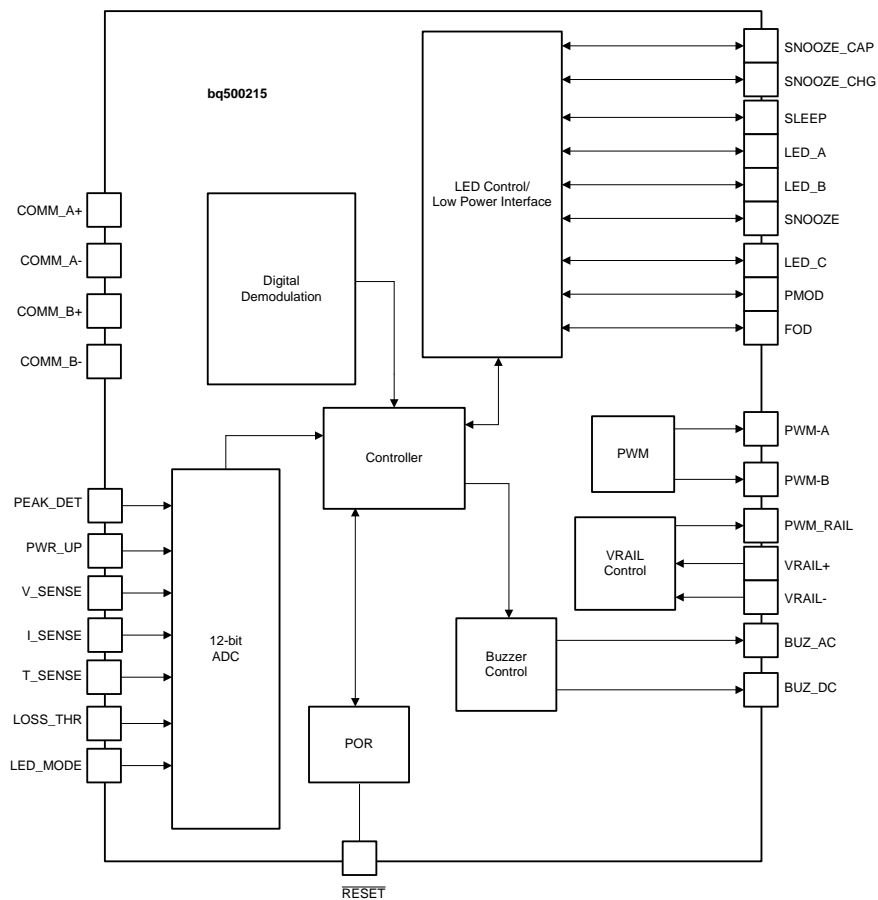

Copyright © 2017, Texas Instruments Incorporated

7.3 Feature Description

7.3.1 A29 Coil Specification

The bq500215 controller supports A29 TX coil type. The coil and matching capacitor specification for A29 transmitter has been established by the WPC Standard. This is fixed and cannot be changed on the transmitter side.

For a current list of coil vendors, see *bqTESLA Transmitter Coil Vendors*, [SLUA649](#).

7.3.2 Option Select Pins

There are two option select pins (pin 60, LOSS_THR, and pin 61, LED_MODE) on the bq500215 and five selector outputs (pins 19, 20, 22, 23, and 24) used to read multiple voltage thresholds. All the pin voltages will be read by bq500215 at power-up.

- Pin 60 is used to program the loss threshold and calibrate the FOD algorithms.
- Pin 61 is used to select the LED mode of the device.
- Pins 19, 20, 22, 23, and 24 are used to sequentially bias the five programming resistors shown in [Figure 4](#).

At power-up, a bias current is applied to pins LED_MODE and LOSS_THR, and the resulting voltage is measured to identify the value of the attached programming resistor. For LED_MODE, the selected bin determines the LED behavior based on [Table 1](#). For the LOSS_THR, the selected bin sets a threshold based on [Table 2](#). See [FOD and Parasitic Metal Object Detect \(PMOD\) Calibration](#) for more information.

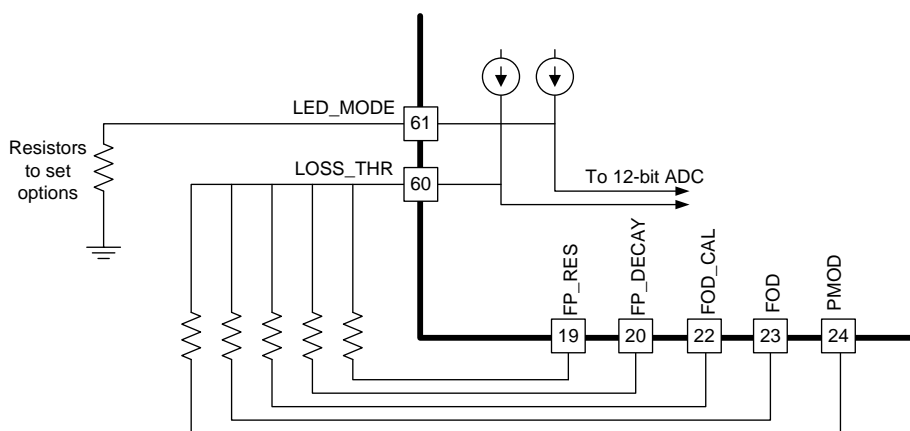

Figure 4. Pin 60 LOSS_THR and Pin 61 LED_MODE Connections

Feature Description (continued)

7.3.3 LED Modes

The bq500215 can directly drive three LED outputs (pin 12, pin 13, and pin 25) through a simple current limit resistor (typically 470 Ω), based on the mode selected. The three current limit resistors can be individually adjusted to tune or match the brightness of the LEDs. Do not exceed the maximum output current rating of the device.

The selection resistor, connected between pin 61 and GND, selects one of the desired LED indication schemes presented in [Table 1](#).

Table 1. LED Modes

LED CONTROL OPTION	LED SELECTION RESISTOR	DESCRIPTION	LED	OPERATIONAL STATES					
				STANDBY	POWER TRANSFER	CHARGE COMPLETE	FAULT	FOD Warning	High Power Transfer ⁽¹⁾
X	<36.5 kΩ	Reserved, do not use	LED_A, green	—	—	—	—	—	—
			LED_B, red						
			LED_C, amber						
1	42.2 kΩ	Choice number 1	LED_A, green	Off	Blink slow ⁽²⁾	On	Off	Off	Blink fast ⁽³⁾
			LED_B, red	Off	Off	Off	On	Blink fast ⁽³⁾	Off ⁽³⁾
			LED_C, amber	—	—	—	—	—	—
2	48.7 kΩ	Choice number 2	LED_A, green	On	Blink slow ⁽²⁾	On	Off	Off	Blink fast ⁽³⁾
			LED_B, red	On	Off	Off	On	Blink fast ⁽³⁾	Off ⁽³⁾
			LED_C, amber	—	—	—	—	—	—
3 ⁽⁴⁾	56.2 kΩ	Choice number 3	LED_A, green	Off	On	Off	Blink fast ⁽³⁾	On	On
			LED_B, red	—	—	—	—	—	—
			LED_C, amber	—	—	—	—	—	—
4	64.9 kΩ	Choice number 4	LED_A, green	Off	On	Off	Off	Off	On
			LED_B, red	Off	Off	Off	On	Blink fast ⁽³⁾	Off
			LED_C, amber	—	—	—	—	—	—
5	75 kΩ	Choice number 5	LED_A, green	Off	Off	On	Off	Off	Off
			LED_B, red	Off	On	Off	Off	On	On
			LED_C, amber	Off	Off	Off	Blink slow ⁽²⁾	Off	Off
6	86.6 kΩ	Choice number 6	LED_A, green	Off	Blink slow ⁽²⁾	On	Off	Off	Blink fast ⁽³⁾
			LED_B, red	Off	Off	Off	On	Blink fast ⁽³⁾	Off
			LED_C, amber	Off	Off	Off	Off	Off	Off
7	100 kΩ	Choice number 7	LED_A, green	Off	Blink slow ⁽²⁾	Off	Off	Off	Blink fast ⁽³⁾
			LED_B, red	Off	Off	On	Off	Off	Off
			LED_C, amber	Off	Off	Off	On	Blink fast ⁽³⁾	Off
8	115 kΩ	Choice number 8	LED_A, green	Off	Off	On	Blink slow ⁽²⁾	Off	Off
			LED_B, red	Off	On	Off	Blink slow ⁽²⁾	On	On
			LED_C, amber	—	—	—	—	—	—
9	133 kΩ	Choice number 9	LED_A, green	Off	Blink slow ⁽²⁾	On	Off	Off	Blink fast ⁽³⁾
			LED_B, red	Off	OFF	Off	On	Blink fast ⁽³⁾	Off
			LED_C, amber	—	—	—	—	—	—
10	154 kΩ	Choice number 10	LED_A, green	Off	On	Off	Blink fast ⁽³⁾	On	On
			LED_B, red	Off	Off	On	Off	Off	Off
			LED_C, amber	—	—	—	—	—	—

(1) Power transfer when operating with bq51025 wireless power receiver

(2) Blink slow = 0.625 Hz

(3) Blink fast = 2.5 Hz

(4) The indication of the shutdown after an negative temperature coefficient (NTC) event may experience a delay in the rapid LED blinking even though the power transfer has been disabled. The indication delay may persist up to as long as the entire NTC FAULT holdoff time.

7.3.4 FOD and Parasitic Metal Object Detect (PMOD) Calibration

The bq500215 supports multiple levels of protection against heating metal objects placed in the magnetic field. An initial analysis of the impulse response to a short ping (FOD ping) detects most metal objects before any power transfer is initiated. If a foreign metallic object is detected by the FOD ping, an FOD warning is issued (see [Table 1](#)) for up to 6 seconds after the object is removed. In the case where a bq51025 receiver with a potential foreign object is detected, the bq500215 transmitter will not configure the receiver in proprietary 10-W mode in order to limit the losses in the foreign object. After power transfer has started, improved FOD (WPC1.2) and enhanced PMOD (WPC 1.0) features continuously monitor input power, known losses, and the value of power reported by the RX device being charged. Using these inputs, the bq500215 can estimate how much power is unaccounted for and presumed lost due to metal objects placed in the wireless power transfer path. If this unexpected loss exceeds the threshold set by the FOD or PMOD resistors, a fault is indicated and power transfer is halted. The ID packet of the receiver being charged determines whether the FOD or PMOD algorithm is used. The ultimate goal of the FOD feature is safety, to protect misplaced metal objects from becoming hot. Reducing the loss threshold and making the system too sensitive leads to false trips and a bad user experience. Find the balance which best suits the application. If the application requires disabling one function or the other (or both), it is possible by leaving the respective FOD/PMOD terminal open. For example, to selectively disable the PMOD function, PMOD should be left open. A final level of protection is provided with an optional temperature sensor to detect any large increase in temperature in the system (see [Shut Down Through External Thermal Sensor or Trigger](#)).

NOTE

Disabling FOD results in a TX solution that is not WPC v1.2 compliant.

Resistors of 1% tolerance should be used for a reliable selection of the desired threshold. The FOD and PMOD resistors (pin 23 and pin 24) program the permitted power loss for the FOD and PMOD algorithms respectively. The FOD_CAL resistor (pin 22), can be used to compensate for any load-dependent effect on the power loss. Using a calibrated FOD reference receiver with no foreign objects present, the FOD_CAL resistor should be selected such that the calculated loss across the load range is substantially constant (within approximately 100 mW). After correcting for the load dependence, the FOD and PMOD thresholds should be re-set above the resulting average by approximately 400 mW for the transmitter to satisfy the WPC requirements on tolerated heating.

Contact TI for the TX tuning tool to set appropriate FOD, PMOD, and FOD_CAL resistor values for your design.

Table 2. Option Select Bins

Bin Number	Resistance (k Ω)	Loss Threshold (mW)
0	<36.5	250
1	42.2	300
2	48.7	350
3	56.2	400
4	64.9	450
5	75.0	500
6	86.6	550
7	100	600
8	115	650
9	133	700
10	154	750
11	178	800
12	205	850
13	>237	Feature disabled

7.3.5 FOD Ping Calibration

The bq500215 is able to detect most metal objects in the charging pad by analyzing the impulse response to a short ping (FOD ping) sent before any power transfer is initiated. The bq500215 does this analysis by measuring the change in resonant frequency and decay of the pulse response and comparing it to given threshold values that are set by resistor in FP_RES and FP_DECAY pins.

Resistors of 1% tolerance should be used for a reliable selection of the desired threshold. The FP_RES and FP_DECAY resistors (pin 19 and pin 20) program the boundary conditions to determine is a receiver or a metal object is detected. The recommended resistor value for both FP_RES and FP_DECAY pins is 86.6 kΩ.

Contact TI for inquiries regarding FOD ping calibration.

NOTE

Removing resistors in FP_DECAY and FP_RES pins disables FOD ping and hence foreign object detection prior to power transfer.

7.3.6 Shut Down Through External Thermal Sensor or Trigger

Typical applications of the bq500215 do not require additional thermal protection. This shutdown feature is provided for enhanced applications and is not limited to thermal shutdown. The key parameter is the 1-V threshold on pin 2, T_SENSE. Voltage below 1-V on pin 2 causes the device to shut down.

The application of thermal monitoring through a negative temperature coefficient (NTC) sensor, for example, is straightforward. The NTC forms the lower leg of a temperature-dependant voltage divider. The NTC leads are connected to the bq500215 device, pin 2 and GND. The threshold on pin 2 is set to 1-V, below which the system shuts down and a fault is indicated (depending on LED mode chosen).

To implement this feature follow these steps:

1. Consult the NTC data sheet and find the resistance versus temperature curve.
2. Determine the actual temperature where the NTC will be placed by using a thermal probe.
3. Read the NTC resistance at that temperature in the NTC data sheet, that is R_NTC.
4. Use the following formula to determine the upper leg resistor (R_Setpoint):

$$R_Setpoint = 2.3 \times R_NTC \tag{1}$$

The system restores normal operation after approximately five minutes or if the receiver is removed. If the feature is not used, this pin must be pulled high.

NOTE

Pin 2, T_SENSE, must always be terminated; otherwise, erratic behavior may occur.

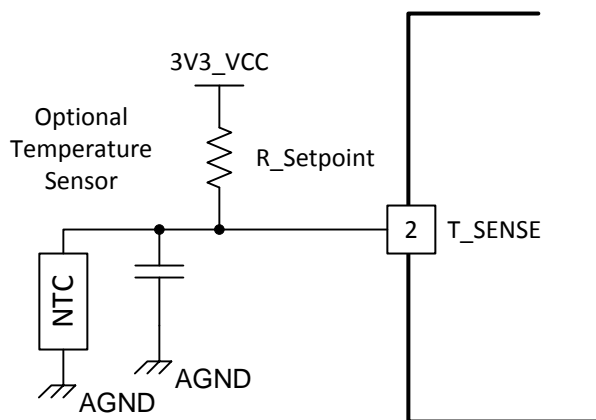

Figure 5. NTC Application

7.3.7 Fault Handling and Indication

Table 3 shows end power transfer (EPT) packet responses, fault conditions, and the duration of how long the condition lasts until a retry is attempted. The LED mode selected determines how the LED indicates the condition or fault.

Table 3. Fault Handling and Indication

CONDITION	DURATION ⁽¹⁾ (BEFORE RETRY)	HANDLING
EPT-00	Immediate ⁽²⁾	Unknown
EPT-01	up to 5 s ⁽³⁾	Charge complete
EPT-02	Infinite	Internal fault
EPT-03	5 minutes	Over temperature
EPT-04	Immediate ⁽²⁾	Over voltage
EPT-05	Immediate ⁽²⁾	Over current
EPT-06	Infinite	Battery failure
EPT-07	Not applicable	Reconfiguration
EPT-08	Immediate ⁽²⁾	No response
OVP (over voltage)	Immediate ⁽²⁾	
OC (over current)	1 minute	
NTC (external sensor)	5 minutes	
PMOD/FOD warning	6 s	4-s LED only, 2-s LED + buzzer
PMOD/FOD	5 minutes	

- (1) After a FAULT, the magnetic field is recharacterized to improve the ability to detect the removal of the at-fault receiver. If the receiver is removed in the first second immediately following the detection of this fault (before the re-characterization is complete), the field corresponding to an empty pad may be associated with the faulty receiver and the LED indication may continue to indicate a fault state even though no receiver is present. This indication persists until either the HOLDOFF time expires or a new receiver disturbs the field, at which time normal operation, with proper LED indication, is resumed.
- (2) Immediate is <1 s.
- (3) The TX may retry immediately (<1 s) to start power after first EPT-01 is received. If the receiver is continuously sending EPT-01, the TX holdoff time will be 5 seconds

7.3.8 Power Transfer Start Signal

The bq500215 features two signal outputs to indicate that power transfer has begun. Pin 31 BUZ_AC outputs a 400-ms duration, 4-kHz square wave for driving low cost AC type ceramic buzzers. Pin 32 BUZ_DC outputs logic high, also for 400-ms, which is suitable for DC type buzzers with built-in tone generators, or as a trigger for any type of customized indication scheme. Do not exceed 4-mA loading from either of these pins which is more than adequate for small signaling and actuation. If not used, these pins should be left open.

7.3.9 Power-On Reset

The bq500215 has an integrated power-on reset (POR) circuit which monitors the supply voltage and handles the correct device startup sequence. Additional supply voltage supervisor or reset circuits are not needed.

7.3.10 External Reset, $\overline{\text{RESET}}$ Pin

The bq500215 can be forced into a reset state by an external circuit connected to the $\overline{\text{RESET}}$ pin. A logic low voltage on this pin holds the device in reset. For normal operation, this pin is pulled up to 3.3-V supply with a 10-k Ω pullup resistor.

7.3.11 Trickle Charge and CS100

The WPC specification provides an EPT message (EPT-01) to indicate charge complete. Upon receipt of the charge complete message, the bq500215 disables the output and changes the LED indication. The exact indication depends on the LED_MODE chosen.

In some battery charging applications, there is a benefit to continue the charging process in trickle-charge mode to top off the battery. The WPC specification provides for an informational 'Charge Status' packet that conveys the level of battery charger. The bq500215 uses this command to enable top-off charging. The bq500215 changes the LED indication to reflect charge complete when a Charge Status message is 100% received, but unlike the response to an EPT, it will not halt power transfer while the LED indicates charge complete. The mobile device can use a CS100 packet to enable trickle charge mode.

If the reported charge status drops below 90%, normal charging indication is resumed.

7.4 Device Functional Modes

7.4.1 Power Transfer

Power transfer depends on coil coupling. Coupling depends on the distance between coils, alignment, coil dimensions, coil materials, number of turns, magnetic shielding, impedance matching, frequency, and duty cycle.

Most importantly, the receiver and transmitter coils must be aligned for best coupling and efficient power transfer. The smaller the space between the coils is, the better the coupling.

Shielding is added as a backing to both the transmitter and receiver coils to direct the magnetic field to the coupled zone. Magnetic fields outside the coupled zone do not transfer power. Thus, shielding also serves to contain the fields to avoid coupling to other adjacent system components.

Regulation can be achieved by controlling any one of the coil coupling parameters. However, for WPC compatibility, the transmitter-side coils and capacitance are specified and the resonant frequency point is fixed. Power transfer is regulated by changing the supply voltage to the full-bridge power stage; higher voltage delivers more power. Duty cycle remains constant at 50% throughout the power band and frequency also remains constant at 130 kHz.

The WPC standard describes the dimensions, materials of the coils, and information regarding the tuning of the coils to resonance. The value of the inductor and resonant capacitor are critical to proper operation and system efficiency.

7.4.2 Communication

Communication within the WPC is from the receiver to the transmitter, where the receiver tells the transmitter to send power and how much. To regulate, the receiver must communicate with the transmitter whether to increase or decrease frequency. The receiver monitors the rectifier output and using amplitude modulation (AM), sends packets of information to the transmitter. A packet is comprised of a preamble, a header, the actual message, and a checksum, as defined by the WPC standard.

The receiver sends a packet by modulating an impedance network. This AM signal reflects back as a change in the voltage amplitude on the transmitter coil. The signal is demodulated and decoded by the transmitter-side electronics and the voltage on the inverter is adjusted to close the regulation loop. The bq500215 features internal digital demodulation circuitry.

The modulated impedance network on the receiver can either be resistive or capacitive. [Figure 6](#) shows the resistive modulation approach, where a resistor is periodically added to the load, and the resulting amplitude change in the transmitter voltage. [Figure 7](#) shows the capacitive modulation approach, where a capacitor is periodically added to the load and the resulting amplitude change in the transmitter voltage.

Device Functional Modes (continued)

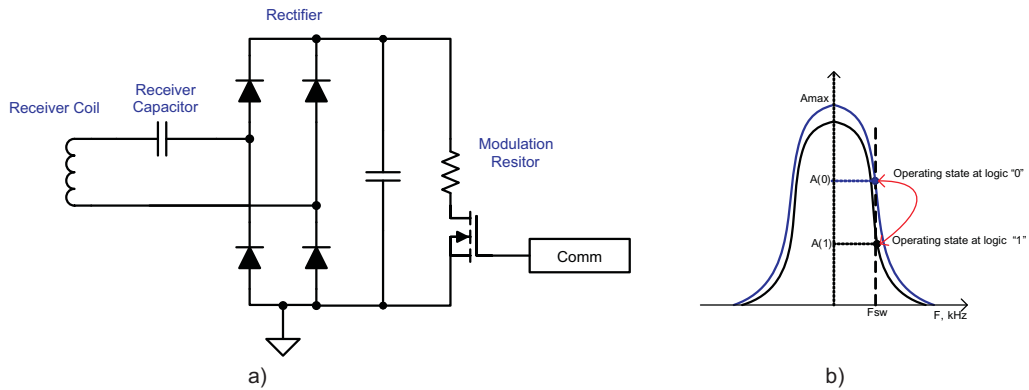

Figure 6. Receiver Resistive Modulation Circuit

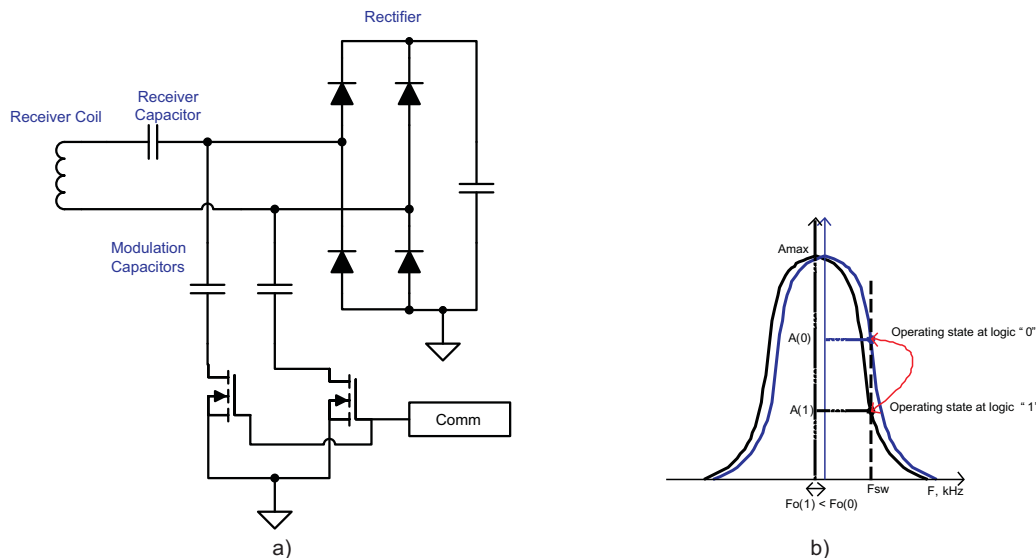

Figure 7. Receiver Capacitive Modulation Circuit

The bq500215 also supports a proprietary handshake with the bq51025 in which minimal communication from the TX to the RX is used. This proprietary handshake enables the bq500215 to deliver power to the bq51025 receiver at levels higher than 5 W. The transmitter-to-receiver communication is achieved through frequency modulation of the power signal.

7.4.3 Power Trains

The bq500215 drives a full-bridge power stage, which drives the coil assembly. TI recommends the CSD97374CQ4M as the driver-plus-MOSFET device for this application. The supply voltage (V_{rail}) is controlled by the bq500215 device.

7.4.4 Power Train Voltage Control

The bq500215 controls power delivery by modulating the supply voltage (V_{rail}) of the power stage driving the coil assembly. The bq500215 device generates a PWM control signal in the PWM_RAIL terminal that controls an external power stage circuit (TI recommends CSD97374CQ4M). The switching frequency for this DC-DC controller signal is 520 kHz.

Device Functional Modes (continued)

7.4.5 Signal Processing Components

The COMM signal used to control power transfer is derived from the coil voltage. The AC coupled coil voltage is scaled down to a manageable level and biased to a 1-V offset. Series connected diodes are provided for protection from any possible transients.

8 Application and Implementation

NOTE

Information in the following applications sections is not part of the TI component specification, and TI does not warrant its accuracy or completeness. TI's customers are responsible for determining suitability of components for their purposes. Customers should validate and test their design implementation to confirm system functionality.

8.1 Application Information

The bq500215 device is a wireless power transmitter controller designed for 5-W WPC compliant applications as well as up to 10-W applications (in combination with the bq51025 wireless receiver). It integrates all functions required to control wireless power transfer to a WPC v1.2 compliant receiver. Several tools are available for the design of the system. See the product folder on www.ti.com for more details. The following sections highlight some of the system design considerations.

8.2 Typical Application

Figure 8 shows the application block diagram for the transmitter.

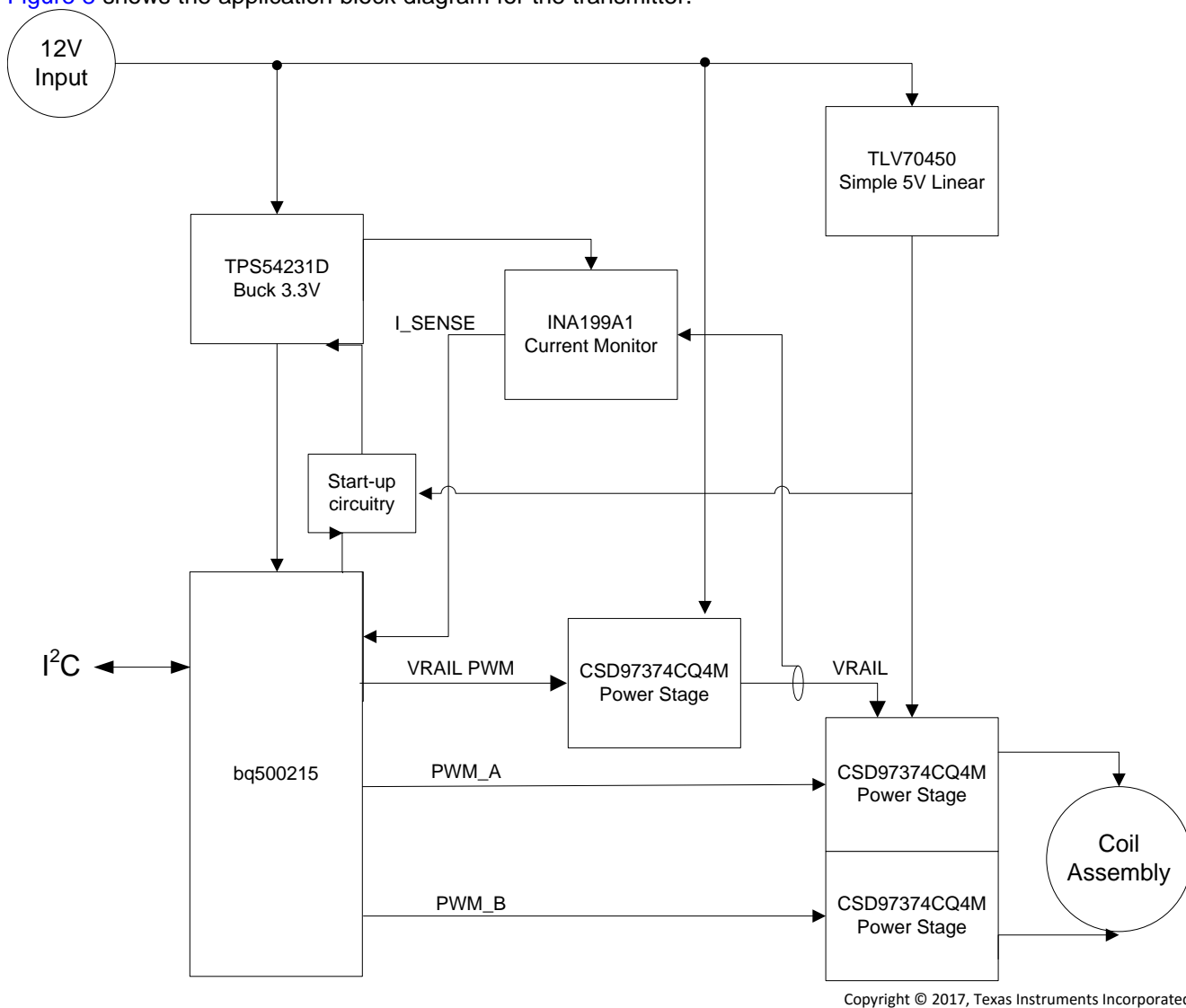

Figure 8. bq500215 System Diagram

Typical Application (continued)

8.2.1 Design Requirements

Table 4. Design Parameters

DESIGN PARAMETER	VALUE
WPC coil type	A29
Input voltage	12 V

8.2.2 Detailed Design Procedure

8.2.2.1 Capacitor Selection

Capacitor selection is critical to proper system operation. The total capacitance value of $2 \times 100 \text{ nF} + 47 \text{ nF}$ is required in the resonant tank. This is the WPC system compatibility requirement, not a guideline.

NOTE

A total capacitance value of $2 \times 100 \text{ nF} + 47 \text{ nF}$ (C0G dielectric type, 100-V rating) is required in the resonant tank to achieve the correct resonance frequency.

The capacitors chosen must be rated for at least 100 V and must be of a high-quality C0G dielectric (sometimes also called NPO). These are typically available in a 5% tolerance, which is adequate. TI does not recommend the use of X7R types or below if WPC compliance is required because critical WPC Certification Testing, such as the minimum modulation or guaranteed power test, might fail.

The designer can combine capacitors to achieve the desired capacitance value. Various combinations can work depending on market availability. All capacitors must be of C0G types (not mixed with any other dielectric types).

8.2.2.2 Current Monitoring Requirements

The bq500215 is WPC v1.2 ready. To enable the PMOD or FOD features, provide current monitoring in the design.

For proper scaling of the current monitor signal, the current sense resistor should be $20 \text{ m}\Omega$ and the current shunt amplifier should have a gain of 50, such as the INA199A1. For FOD accuracy, the current sense resistor must be a quality component with 0.5% tolerance, at least 1/4-W rating, and a temperature stability of $\pm 200 \text{ PPM}$. Proper current sensing techniques in the application hardware should also be observed.

8.2.2.3 All Unused Pins

All unused pins can be left open unless otherwise indicated. Refer to the table in [Pin Configuration and Functions](#). To improve PCB layout, ground unused pins, if it is an option.

8.2.2.4 Input Regulators

The bq500215 requires $3.3 \text{ V}_{\text{DC}}$ to operate. A buck converter is used to step down from the supply voltage, such as the TPS54231D used in this design.

8.2.2.5 Input Power Requirements

The design works with 12-V input voltage. A29 TX type requires 12-V system voltage.

8.2.2.6 LED Mode

bq500215 can directly drive three LED outputs (pin 12 (LED-A), pin 13 (LED-B), and pin 25 (LED-C)). Select one of the desired LED indication schemes by choosing the selection resistor connected between pin 61 (LED_MODE) and GND.

8.2.3 Application Curves

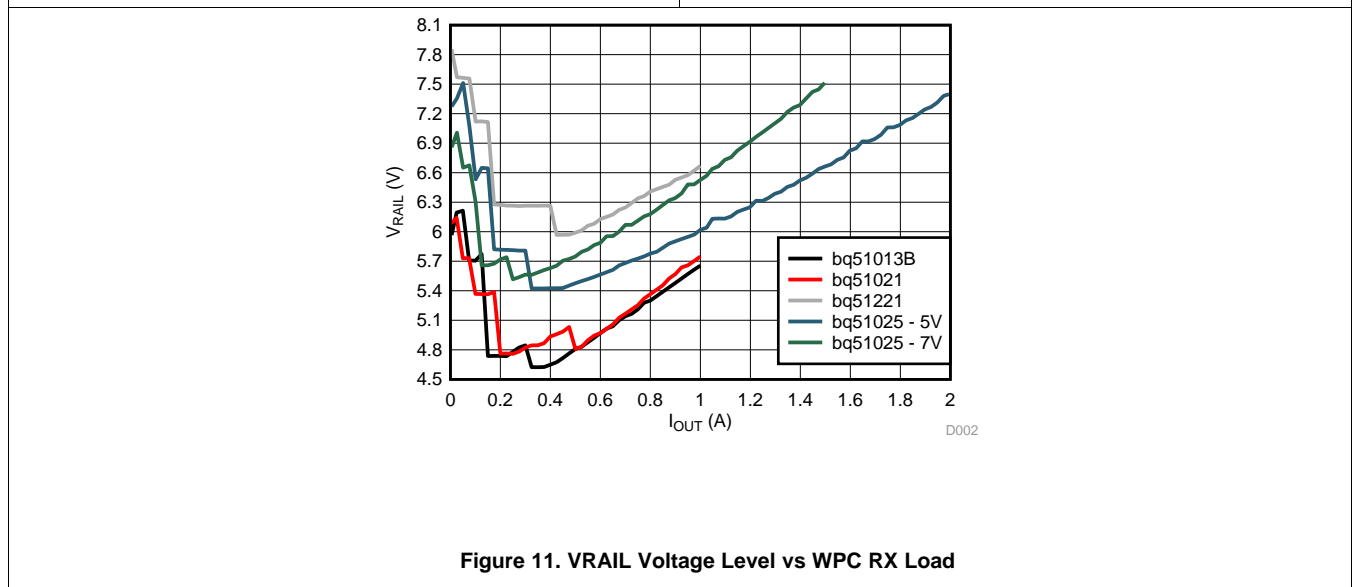
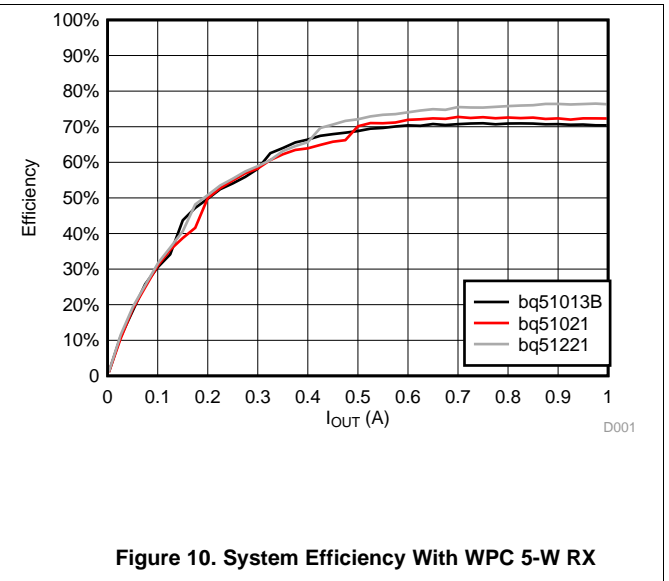
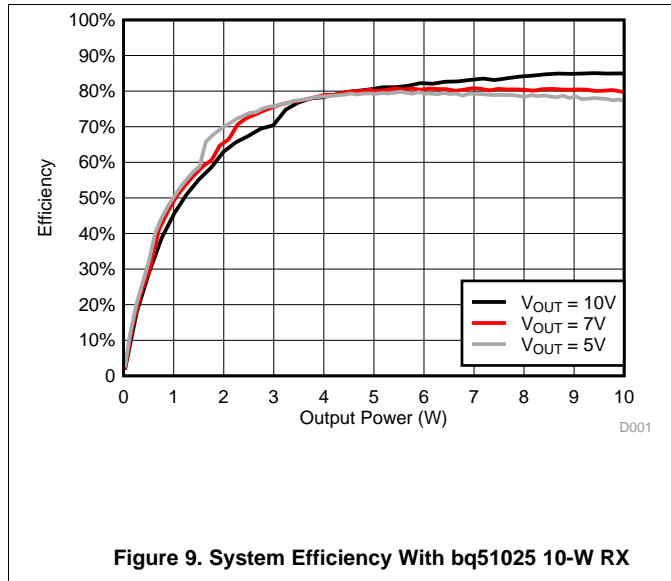

9 Power Supply Recommendations

This device is designed to operate from an input voltage supply range between 3- to 3.6-V, nominal 3.3-V. The A29 TX type requires a 12-V system voltage.

10 Layout

10.1 Layout Guidelines

Careful PCB layout practice is critical to proper system operation. Many references are available on proper PCB layout techniques. A few good tips are as follows:

The TX layout requires a 4-layer PCB layout for best ground plane technique. A 2-layer PCB layout can be achieved though not as easily. Ideally, the approach to the layer stack-up is:

- Layer 1 component placement and as much ground plane as possible
- Layer 2 clean ground
- Layer 3 finish routing
- Layer 4 clean ground

Thus, the circuitry is virtually sandwiched between grounds. This minimizes EMI noise emissions and also provides a noise-free voltage reference plane for device operation.

Keep as much copper as possible. Make sure the bq500215 GND pins and the EPAD GND power pad have a continuous flood connection to the ground plane. The power pad should also be stitched to the ground plane, which also acts as a heat sink for the bq500215. A good GND reference is necessary for proper bq500215 operation, such as analog-digital conversion, clock stability, and best overall EMI performance.

Separate the analog ground plane from the power ground plane and use only **one** tie point to connect grounds. Having several tie points defeats the purpose of separating the grounds.

The COMM return signal from the resonant tank should be routed as a differential pair. This is intended to reduce stray noise induction. The frequencies of concern warrant low-noise analog signaling techniques, such as differential routing and shielding, but the COMM signal lines do not need to be impedance matched.

The DC-DC buck regulator used from the 12-V input supplies the bq500215 with 3.3-V. Typically, the designer uses a single-chip controller solution with integrated power FET and synchronous rectifier or outboard diode. Pull in the buck inductor and power loop as close as possible to create a tight loop. Likewise, the power-train, full-bridge components should be pulled together as tight as possible. See the bq500215 EVM for an example of a good layout technique.

10.2 Layout Example

A DC-DC buck regulator is used to step down the system voltage to the 3.3-V supply to the bq500215. The system voltage is 12-V; with such a step-down ratio, switching duty-cycle is low and the regulator is mostly freewheeling. Therefore, place the freewheeling diode current loop as close to the switching regulator as possible and use wide traces. Place the buck inductor and power loop as close to that as possible to minimize current path.

Layout Example (continued)

Place 3.3-V buck regulator input bypass capacitors as close as possible to the buck IC.

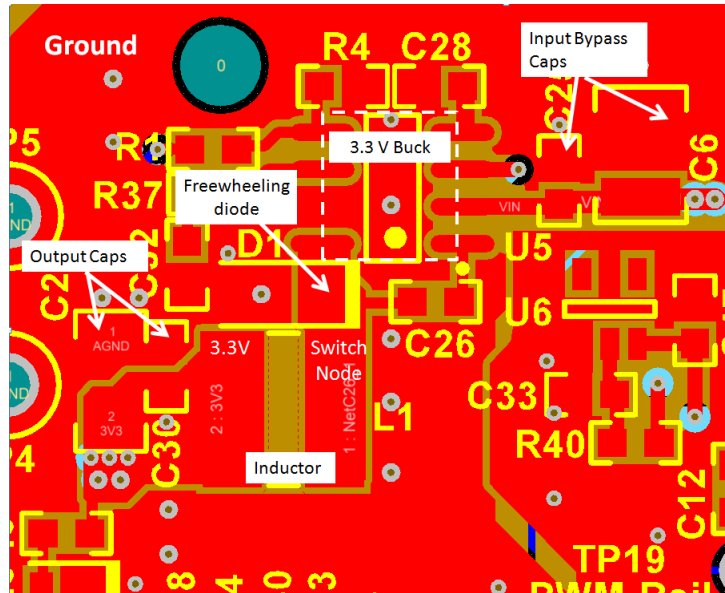

Figure 12. 3.3-V DC-DC Buck Regulator Layout

Make sure the bypass capacitors intended for the bq500215 3.3-V supply are actually bypassing these supply pins (pin 44, V33DIO, pin 45, V33D, and pin 46, V33A) to solid ground plane. This means they need to be placed as close to the device as possible and the traces must be as wide as possible.

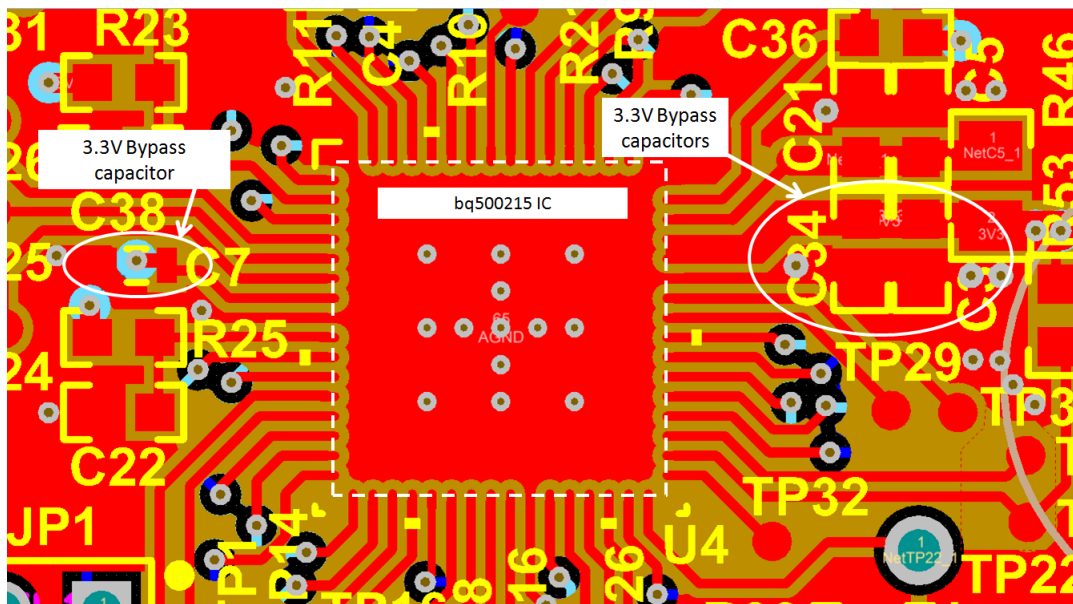

Figure 13. Bypass Capacitors Layout

Layout Example (continued)

Make sure the bq500215 has a continuous flood connection to the ground plane.

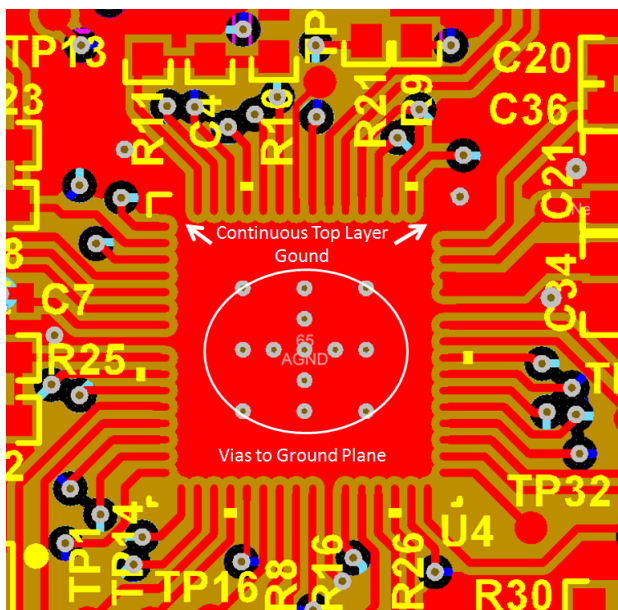

Figure 14. Continuous GND Layout

A buck regulator is used to regulate the supply voltage to the full bridge. The buck power stage IC is controlled by a PWM signal generated by the bq500215 IC, and it is directly powered from the 12-V input supply. Because the buck output voltage can operate at a wide voltage range, significant current low is expected in both the buck power stage input and ground connections. Make sure wide traces and continuous pours are used for input and ground. Place input bypass capacitors, output capacitor and inductor as close as possible to the buck power stage to make the current loop as small as possible.

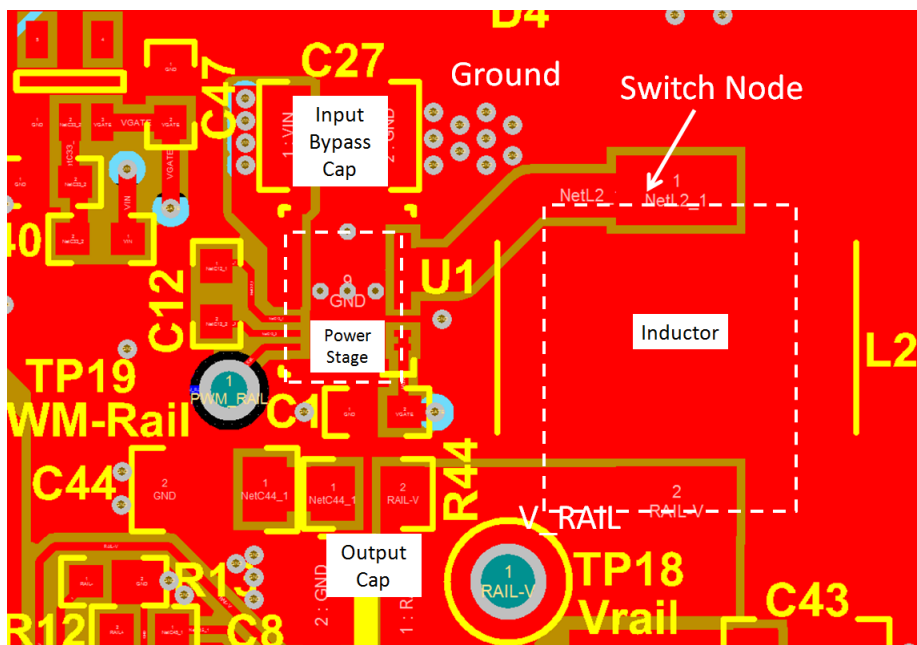

Figure 15. V_RAIL Power Stage Layout

Layout Example (continued)

The full-bridge power stage that drives the TX coil is composed of two half-bridge power stages and resonant capacitors. Inputs bypass capacitors should be placed as close as possible to the power stage ICs. The input and ground pours and traces should be made as wide as possible for better current flow. The trace to the coil and resonant capacitors should also be made as wide as possible.

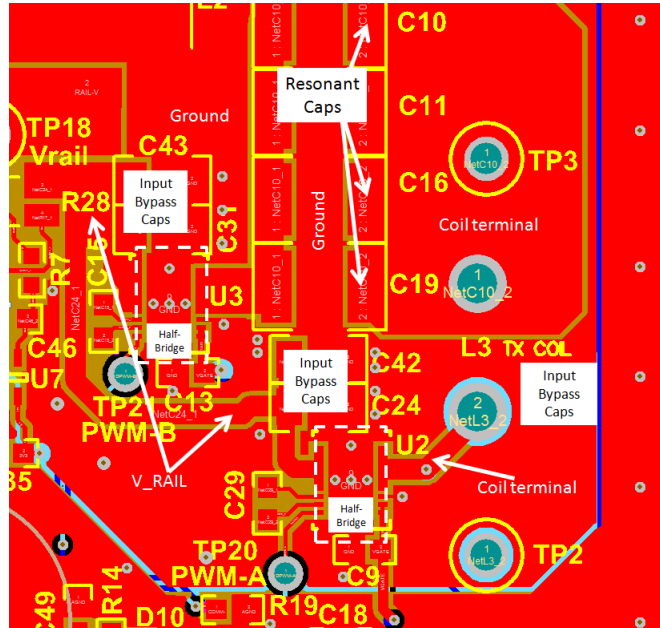

Figure 16. Ground Layout

To ensure proper operation, grounds conducting a large amount of current and switching noise must be isolated from low current, quiet grounds. Separate the ground pours for the power stages and the bq500215 IC. Connect all grounds to a single point at the main ground terminal.

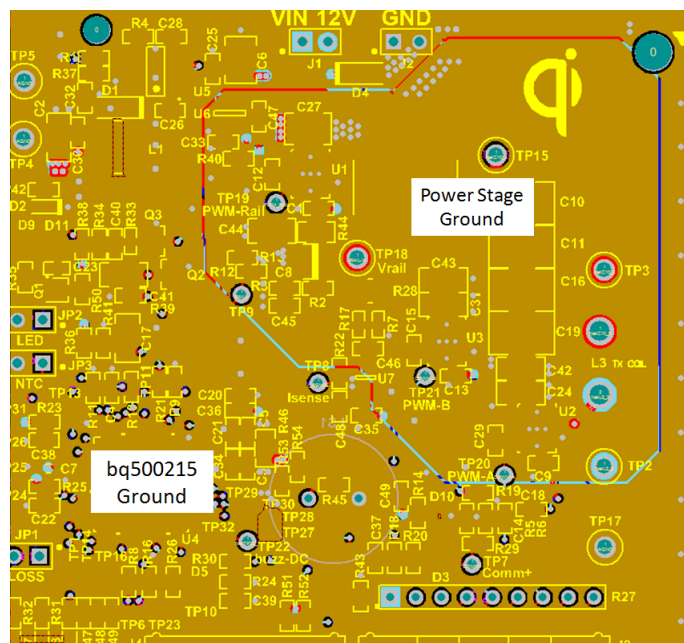

Figure 17. Ground Layout

Layout Example (continued)

A bypass capacitor needs to be connected between the point where the 3.3-V bias supply is connected to the COMM+ resistor divider and the divider/COMM– ground connection.

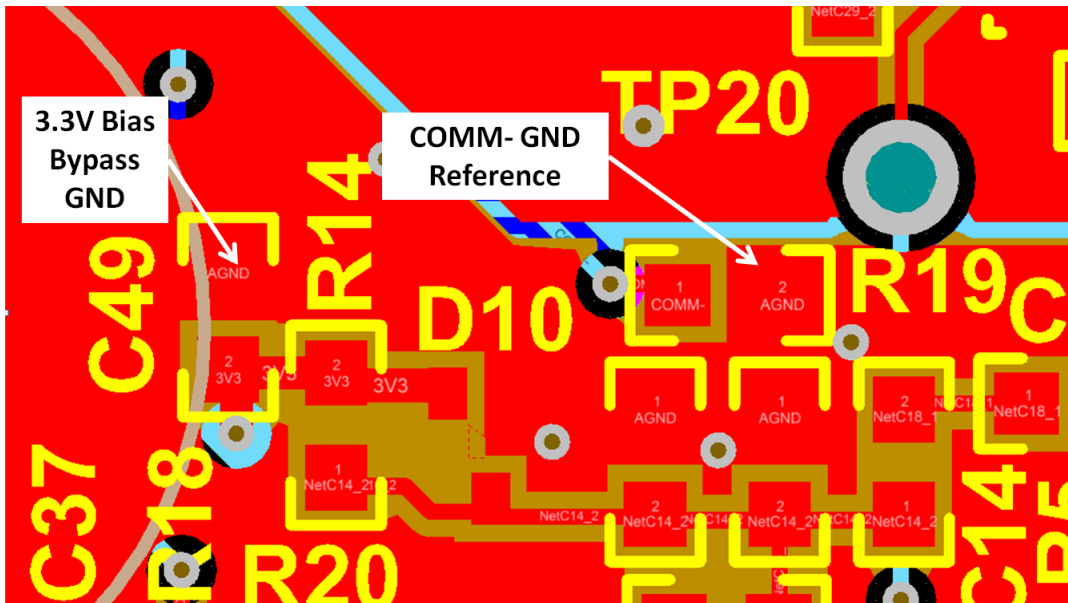

Figure 20. Bypass Capacitors Layout for COMM+ Resistor Divider 3.3-V Bias

11 Device and Documentation Support

11.1 Device Support

1. Technology, *Wireless Power Consortium*, www.wirelesspowerconsortium.com/
2. Analog applications journal, *An Introduction to the Wireless Power Consortium Standard and TI's Compliant Solutions*, Johns, Bill, [SLYT401](#)
3. Data sheet, *Qi Compliant Wireless Power Transmitter Manager*, [SLUSAL8](#)
4. Data sheet, *Integrated Wireless Power Supply Receiver, Qi (WPC) Compliant*, bq51011, bq51013, [SLVSAT9](#)
5. Data sheet, *bq51025 WPC v1.1 Compliant Single Chip Wireless Power Receiver With Proprietary 10-W Power Delivery*, [SLUSBX7](#)
6. Application note, *Building a Wireless Power Transmitter*, [SLUA635](#)
7. Application note, *bqTESLA Transmitter Coil Vendors*, [SLUA649](#)

11.2 Receiving Notification of Documentation Updates

To receive notification of documentation updates, navigate to the device product folder on ti.com. In the upper right corner, click on *Alert me* to register and receive a weekly digest of any product information that has changed. For change details, review the revision history included in any revised document.

11.3 Community Resources

The following links connect to TI community resources. Linked contents are provided "AS IS" by the respective contributors. They do not constitute TI specifications and do not necessarily reflect TI's views; see TI's [Terms of Use](#).

TI E2E™ Online Community *TI's Engineer-to-Engineer (E2E) Community*. Created to foster collaboration among engineers. At e2e.ti.com, you can ask questions, share knowledge, explore ideas and help solve problems with fellow engineers.

Design Support *TI's Design Support* Quickly find helpful E2E forums along with design support tools and contact information for technical support.

11.4 Trademarks

E2E is a trademark of Texas Instruments.
All other trademarks are the property of their respective owners.

11.5 Electrostatic Discharge Caution



These devices have limited built-in ESD protection. The leads should be shorted together or the device placed in conductive foam during storage or handling to prevent electrostatic damage to the MOS gates.

11.6 Glossary

[SLYZ022](#) — *TI Glossary*.

This glossary lists and explains terms, acronyms, and definitions.

12 Mechanical, Packaging, and Orderable Information

The following pages include mechanical, packaging, and orderable information. This information is the most current data available for the designated devices. This data is subject to change without notice and revision of this document. For browser-based versions of this data sheet, refer to the left-hand navigation.

PACKAGING INFORMATION

Orderable Device	Status (1)	Package Type	Package Drawing	Pins	Package Qty	Eco Plan (2)	Lead/Ball Finish (6)	MSL Peak Temp (3)	Op Temp (°C)	Device Marking (4/5)	Samples
BQ500215RGCR	NRND	VQFN	RGC	64	2000	Green (RoHS & no Sb/Br)	CU NIPDAU	Level-3-260C-168 HR	-40 to 85	BQ500215	
BQ500215RGCT	NRND	VQFN	RGC	64	250	Green (RoHS & no Sb/Br)	CU NIPDAU	Level-3-260C-168 HR	-40 to 85	BQ500215	

(1) The marketing status values are defined as follows:

ACTIVE: Product device recommended for new designs.

LIFEBUY: TI has announced that the device will be discontinued, and a lifetime-buy period is in effect.

NRND: Not recommended for new designs. Device is in production to support existing customers, but TI does not recommend using this part in a new design.

PREVIEW: Device has been announced but is not in production. Samples may or may not be available.

OBSOLETE: TI has discontinued the production of the device.

(2) **RoHS:** TI defines "RoHS" to mean semiconductor products that are compliant with the current EU RoHS requirements for all 10 RoHS substances, including the requirement that RoHS substance do not exceed 0.1% by weight in homogeneous materials. Where designed to be soldered at high temperatures, "RoHS" products are suitable for use in specified lead-free processes. TI may reference these types of products as "Pb-Free".

RoHS Exempt: TI defines "RoHS Exempt" to mean products that contain lead but are compliant with EU RoHS pursuant to a specific EU RoHS exemption.

Green: TI defines "Green" to mean the content of Chlorine (Cl) and Bromine (Br) based flame retardants meet JS709B low halogen requirements of <=1000ppm threshold. Antimony trioxide based flame retardants must also meet the <=1000ppm threshold requirement.

(3) MSL, Peak Temp. - The Moisture Sensitivity Level rating according to the JEDEC industry standard classifications, and peak solder temperature.

(4) There may be additional marking, which relates to the logo, the lot trace code information, or the environmental category on the device.

(5) Multiple Device Markings will be inside parentheses. Only one Device Marking contained in parentheses and separated by a "~" will appear on a device. If a line is indented then it is a continuation of the previous line and the two combined represent the entire Device Marking for that device.

(6) Lead/Ball Finish - Orderable Devices may have multiple material finish options. Finish options are separated by a vertical ruled line. Lead/Ball Finish values may wrap to two lines if the finish value exceeds the maximum column width.

Important Information and Disclaimer:The information provided on this page represents TI's knowledge and belief as of the date that it is provided. TI bases its knowledge and belief on information provided by third parties, and makes no representation or warranty as to the accuracy of such information. Efforts are underway to better integrate information from third parties. TI has taken and continues to take reasonable steps to provide representative and accurate information but may not have conducted destructive testing or chemical analysis on incoming materials and chemicals. TI and TI suppliers consider certain information to be proprietary, and thus CAS numbers and other limited information may not be available for release.

In no event shall TI's liability arising out of such information exceed the total purchase price of the TI part(s) at issue in this document sold by TI to Customer on an annual basis.

TAPE AND REEL INFORMATION

QUADRANT ASSIGNMENTS FOR PIN 1 ORIENTATION IN TAPE

*All dimensions are nominal

Device	Package Type	Package Drawing	Pins	SPQ	Reel Diameter (mm)	Reel Width W1 (mm)	A0 (mm)	B0 (mm)	K0 (mm)	P1 (mm)	W (mm)	Pin1 Quadrant
BQ500215RGCR	VQFN	RGC	64	2000	330.0	16.4	9.3	9.3	1.1	12.0	16.0	Q2
BQ500215RGCT	VQFN	RGC	64	250	180.0	16.4	9.3	9.3	1.1	12.0	16.0	Q2

TAPE AND REEL BOX DIMENSIONS

*All dimensions are nominal

Device	Package Type	Package Drawing	Pins	SPQ	Length (mm)	Width (mm)	Height (mm)
BQ500215RGCR	VQFN	RGC	64	2000	367.0	367.0	38.0
BQ500215RGCT	VQFN	RGC	64	250	210.0	185.0	35.0

GENERIC PACKAGE VIEW

RGC 64

VQFN - 1 mm max height

9 x 9, 0.5 mm pitch

PLASTIC QUAD FLATPACK - NO LEAD

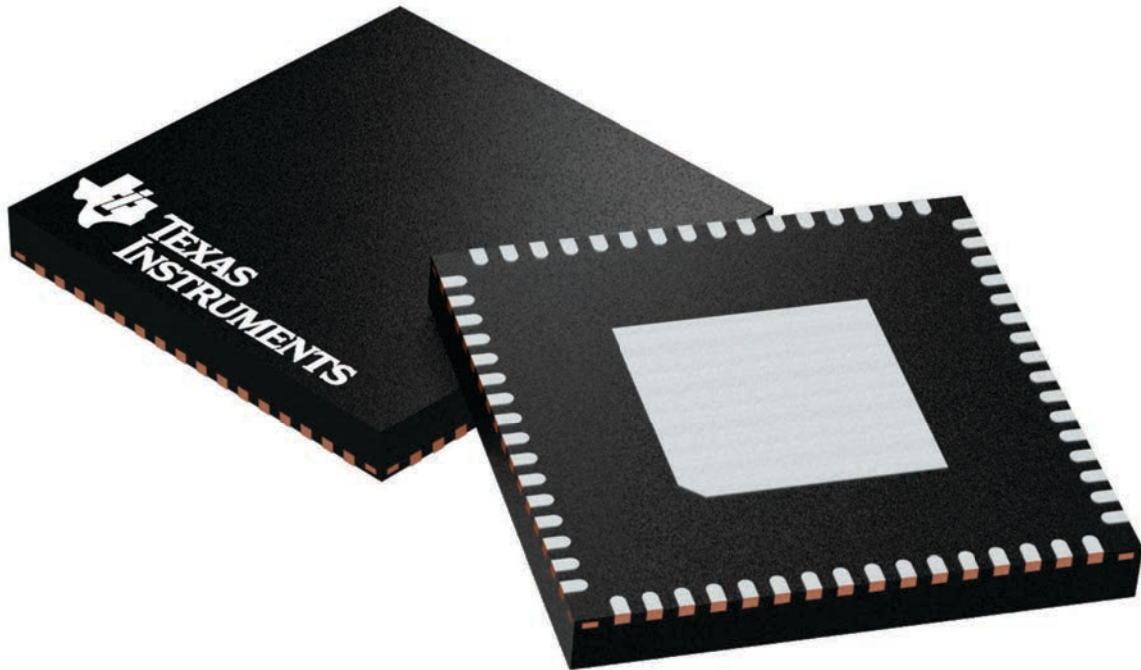

Images above are just a representation of the package family, actual package may vary.
Refer to the product data sheet for package details.

4224597/A

RGC0064B

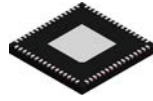

PACKAGE OUTLINE

VQFN - 1 mm max height

PLASTIC QUAD FLATPACK - NO LEAD

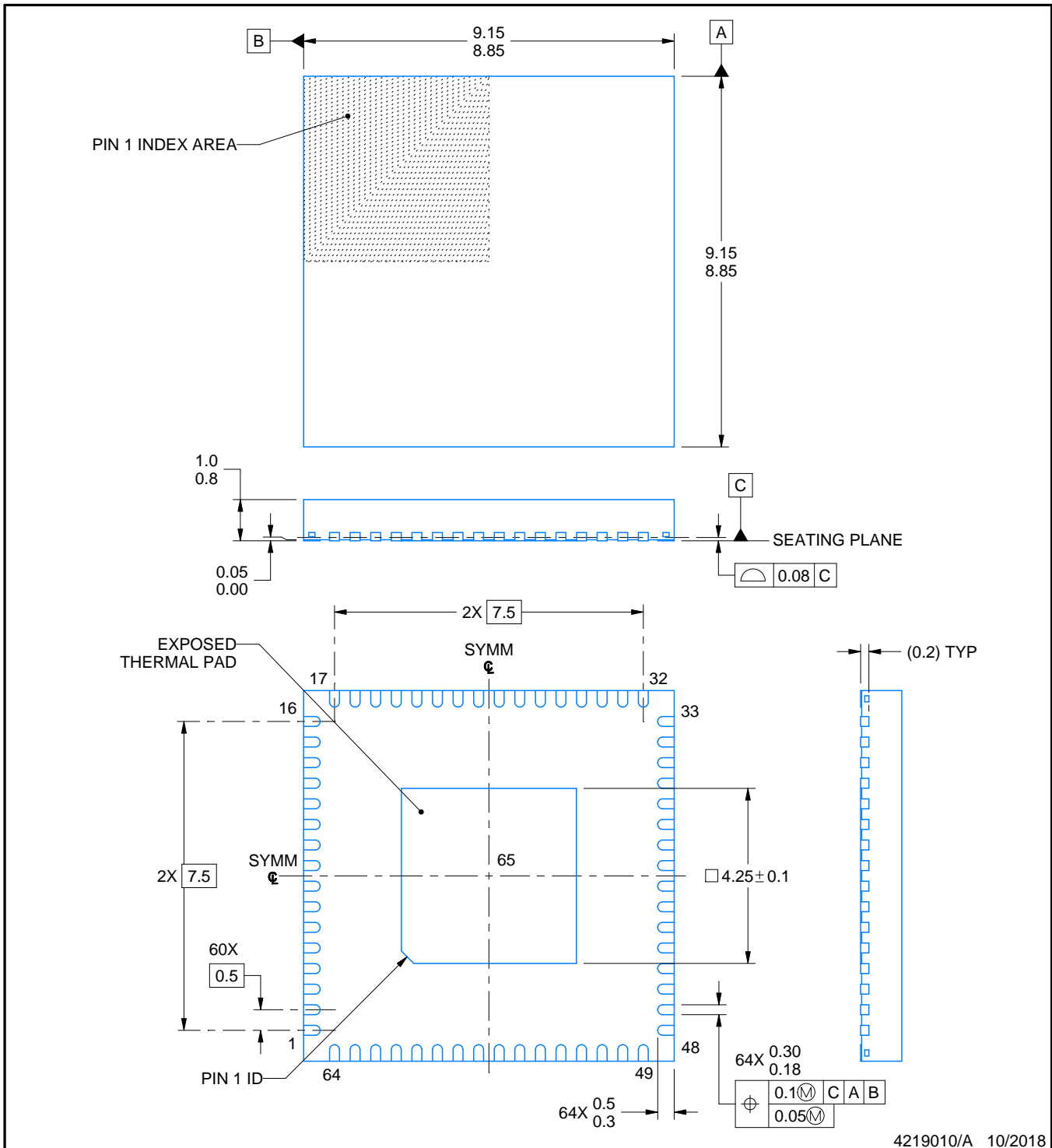

4219010/A 10/2018

NOTES:

1. All linear dimensions are in millimeters. Any dimensions in parenthesis are for reference only. Dimensioning and tolerancing per ASME Y14.5M.
2. This drawing is subject to change without notice.
3. The package thermal pad must be soldered to the printed circuit board for thermal and mechanical performance.

EXAMPLE BOARD LAYOUT

RGC0064B

VQFN - 1 mm max height

PLASTIC QUAD FLATPACK - NO LEAD

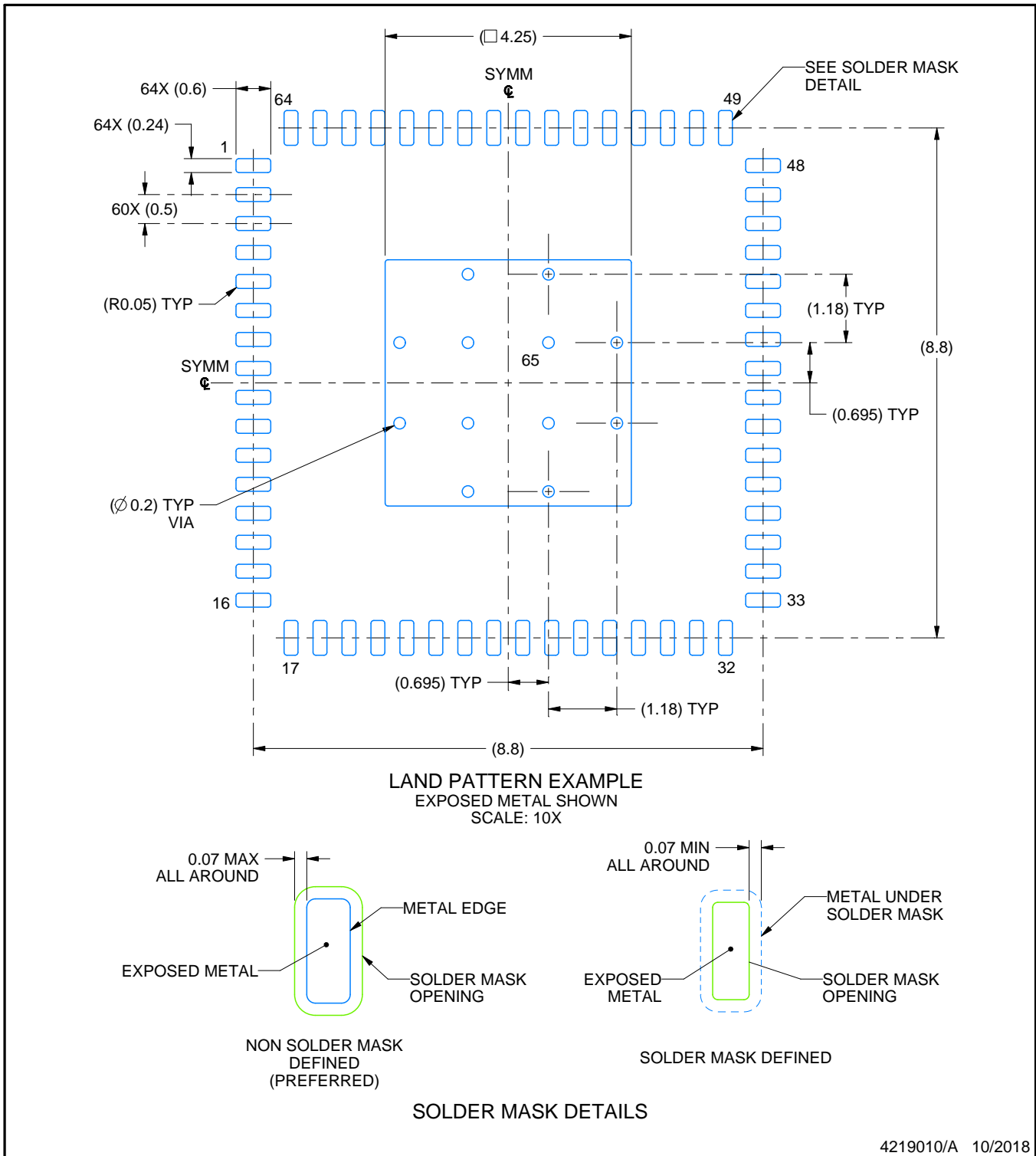

4219010/A 10/2018

NOTES: (continued)

4. This package is designed to be soldered to a thermal pad on the board. For more information, see Texas Instruments literature number SLUA271 (www.ti.com/lit/slue271).
5. Vias are optional depending on application, refer to device data sheet. If any vias are implemented, refer to their locations shown on this view. It is recommended that vias under paste be filled, plugged or tented.

IMPORTANT NOTICE AND DISCLAIMER

TI PROVIDES TECHNICAL AND RELIABILITY DATA (INCLUDING DATASHEETS), DESIGN RESOURCES (INCLUDING REFERENCE DESIGNS), APPLICATION OR OTHER DESIGN ADVICE, WEB TOOLS, SAFETY INFORMATION, AND OTHER RESOURCES "AS IS" AND WITH ALL FAULTS, AND DISCLAIMS ALL WARRANTIES, EXPRESS AND IMPLIED, INCLUDING WITHOUT LIMITATION ANY IMPLIED WARRANTIES OF MERCHANTABILITY, FITNESS FOR A PARTICULAR PURPOSE OR NON-INFRINGEMENT OF THIRD PARTY INTELLECTUAL PROPERTY RIGHTS.

These resources are intended for skilled developers designing with TI products. You are solely responsible for (1) selecting the appropriate TI products for your application, (2) designing, validating and testing your application, and (3) ensuring your application meets applicable standards, and any other safety, security, or other requirements. These resources are subject to change without notice. TI grants you permission to use these resources only for development of an application that uses the TI products described in the resource. Other reproduction and display of these resources is prohibited. No license is granted to any other TI intellectual property right or to any third party intellectual property right. TI disclaims responsibility for, and you will fully indemnify TI and its representatives against, any claims, damages, costs, losses, and liabilities arising out of your use of these resources.

TI's products are provided subject to TI's Terms of Sale (www.ti.com/legal/termsofsale.html) or other applicable terms available either on ti.com or provided in conjunction with such TI products. TI's provision of these resources does not expand or otherwise alter TI's applicable warranties or warranty disclaimers for TI products.

Mailing Address: Texas Instruments, Post Office Box 655303, Dallas, Texas 75265
Copyright © 2019, Texas Instruments Incorporated

Looking for pricing, stock, or lifecycle information?

Click below to explore more details on WIN SOURCE:

 [View BQ500215RGCT](#) on WIN SOURCE

 [Texas Instruments](#) Information

Optimize Your Supply Chain with WIN SOURCE Solutions

-  Global Sourcing Solution
-  Obsolete Management
-  Cost Control Management
-  Shortage Management
-  Alternative Solution
-  Excess Inventory Management