



**THE DATASHEET OF  
BQ51013AYFPT**



## INTEGRATED WIRELESS POWER SUPPLY RECEIVER, Qi (WIRELESS POWER CONSORTIUM) COMPLIANT

Check for Samples: [bq51013A](#), [bq51014](#)

### FEATURES

- **Integrated Wireless Power Receiver Solution with a 5V Regulated Supply**
  - 93% Overall Peak AC-DC Efficiency
  - Full Synchronous Rectifier
  - WPC v1.0 Compliant Communication Control
  - Output Voltage Conditioning
  - Only IC Required Between RX coil and 5V DC Output Voltage
- **Dynamic Rectifier Control** for Improved Load Transient Response
- **Dynamic Efficiency Scaling** for Optimized Performance Over any Range of Output Power
- **Adaptive Communication Limit** for Robust Communication During High Levels of Load Current Noise
- **Supports 20-V Maximum Input**
- **Low-power Dissipative Rectifier Overvoltage Clamp** ( $V_{OVP} = 15V$ )
- **Thermal Shutdown**
- **Multifunction NTC and Control Pin** for Temperature Monitoring, Done Charging and Fault Host Control
- **Stand-alone Digital Controller**
- **Programmable Termination Pin** for Charge Status 100% (CS100) Support
- **1.9 x 3mm DSBG or 4.5 x 3.5mm QFN Package**

### APPLICATIONS

- WPC Compliant Receivers
- Cell Phones, Smart Phones
- Headsets
- Digital Cameras
- Portable Media Players
- Hand-held Devices

### DESCRIPTION

The bq5101x is an advanced, integrated, receiver IC for wireless power transfer in portable applications. The device provides the AC/DC power conversion while integrating the digital control required to comply with the Qi v1.0 communication protocol. Together with the bq500210 transmitter controller, the bq5101x enables a complete contact-less power transfer system for a wireless power supply solution. By using near-field inductive power transfer, the receiver coil embedded in the portable device receives the power transmitted by the transmitter coil via mutually coupled inductors. The AC signal from the receiver coil is then rectified and regulated to be used as a power supply for down-system electronics. Global feedback is established from the secondary to the transmitter in order to stabilize the power transfer process via back-scatter modulation. This feedback is established by using the Qi v1.0 communication protocol supporting up to 5 W applications.

The device integrates a low-impedance full synchronous rectifier, low-dropout regulator, digital control, and accurate voltage and current loops. The entire power stage (rectifier and LDO) use low resistive NMOS FET's to ensures high efficiency and low power dissipation.

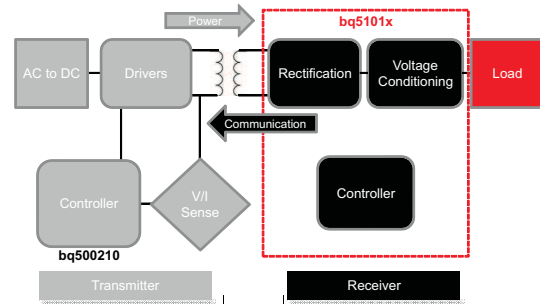

**Figure 1. Wireless Power Consortium (WPC or Qi) Inductive Power System**



Please be aware that an important notice concerning availability, standard warranty, and use in critical applications of Texas Instruments semiconductor products and disclaimers thereto appears at the end of this data sheet.

**bq51013A**  
**bq51014**

SLUSAY6B – MARCH 2012 – REVISED OCTOBER 2013

www.ti.com



These devices have limited built-in ESD protection. The leads should be shorted together or the device placed in conductive foam during storage or handling to prevent electrostatic damage to the MOS gates.

### ORDERING INFORMATION

Part NO	Marking	Function	Package	Ordering Number (Tape and Reel)	Quantity
bq51013A	bq51013A	5V Regulated Power Supply	DSBGA-YFP	bq51013AYFPR	3000
				bq51013AYFPT	250
			QFN-RHL	bq51013ARHLR	3000
				bq51013ARHLT	250
bq51014	bq51014	5V Regulated Power Supply	DSBGA-YFP	bq51014YFPR	3000
				bq51014YFPT	250

### AVAILABLE OPTIONS

Device	Function	WPC Version	V <sub>RECT-OVP</sub>	V <sub>OUT-(REG)</sub>	Over Current Shutdown	AD-OVP	Termination (CS100)	Communication Current Limit <sup>(1)</sup> (2)
bq51013A	5V Power Supply	v1.0	15V	5V	Disabled	Disabled	Disabled	Tracking + 1s Hold-Off
bq51014	5V Power Supply	v1.0	15V	5V	Enabled	12.5V	Enabled	Tracking + 1s Hold-Off

(1) Enabled if EN2 is low and disabled if EN2 is high

(2) Communication current limit is disabled for 1 second at startup

### ABSOLUTE MAXIMUM RATINGS<sup>(1)(2)</sup>

over operating free-air temperature range (unless otherwise noted)

PARAMETER	PIN	VALUES		UNITS
		MIN	MAX	
Input Voltage	AC1, AC2	-0.8	20	V
	RECT, COM1, COM2, OUT, $\overline{\text{CHG}}$ , CLAMP1, CLAMP2	-0.3	20	V
	AD, $\overline{\text{AD-EN}}$	-0.3	30	V
	BOOT1, BOOT2	-0.3	26	V
	EN1, EN2, TERM, FOD, TS-CTRL, ILIM	-0.3	7	V
Input Current	AC1, AC2		2	A(RMS)
Output Current	OUT		1.5	A
Output Sink Current	$\overline{\text{CHG}}$		15	mA
	COM1, COM2		1	A
Junction temperature, T <sub>J</sub>		-40	150	°C
Storage temperature, T <sub>STG</sub>		-65	150	°C
ESD Rating (HBM) (100pF, 1.5KΩ)	All	2		kV

(1) All voltages are with respect to the VSS terminal, unless otherwise noted.

(2) Stresses beyond those listed under absolute maximum ratings may cause permanent damage to the device. These are stress ratings only, and functional operation of the device at these or any other conditions beyond those indicated under recommended operating conditions is not implied. Exposure to absolute-maximum-rated conditions for extended periods may affect device reliability.

## THERMAL INFORMATION

THERMAL METRIC <sup>(1)</sup>		RHL	YFP	UNITS
		20 PINS	28 PINS	
$\theta_{JA}$	Junction-to-ambient thermal resistance	37.7	58.9	°C/W
$\theta_{JcTop}$	Junction-to-case (top) thermal resistance	35.5	0.2	
$\theta_{JB}$	Junction-to-board thermal resistance	13.6	9.1	
$\psi_{JT}$	Junction-to-top characterization parameter	0.5	1.4	
$\psi_{JB}$	Junction-to-board characterization parameter	13.5	8.9	
$\theta_{JcBot}$	Junction-to-case (bottom) thermal resistance	2.7	n/a	

(1) For more information about traditional and new thermal metrics, see the *IC Package Thermal Metrics* application report, [SPRA953](#).

## RECOMMENDED OPERATING CONDITIONS

over operating free-air temperature range (unless otherwise noted)

PARAMETER	PINS	MIN	MAX	UNITS
Input voltage range, $V_{IN}$	RECT	4	10	V
Input current, $I_{IN}$	RECT		1.5	A
Output current, $I_{OUT}$	OUT		1.5	A
Sink current, $I_{AD-EN}$	$\overline{AD-EN}$		1	mA
COMM sink current, $I_{COMM}$	COMM		500	mA
Junction Temperature, $T_J$		0	125	°C

**TYPICAL APPLICATION SCHEMATICS**

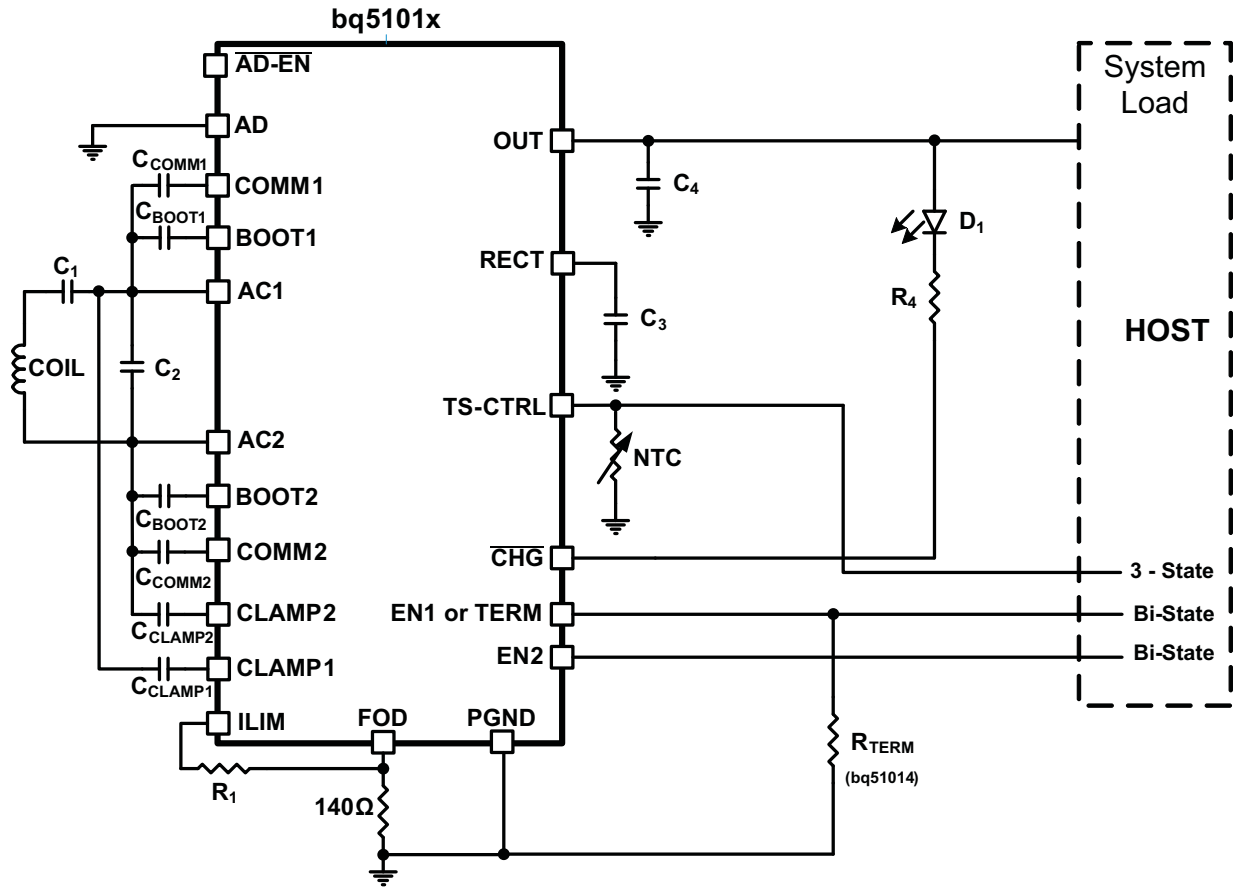

**Figure 2. bq5101x Used as a Wireless Power Receiver and Power Supply for System Loads**

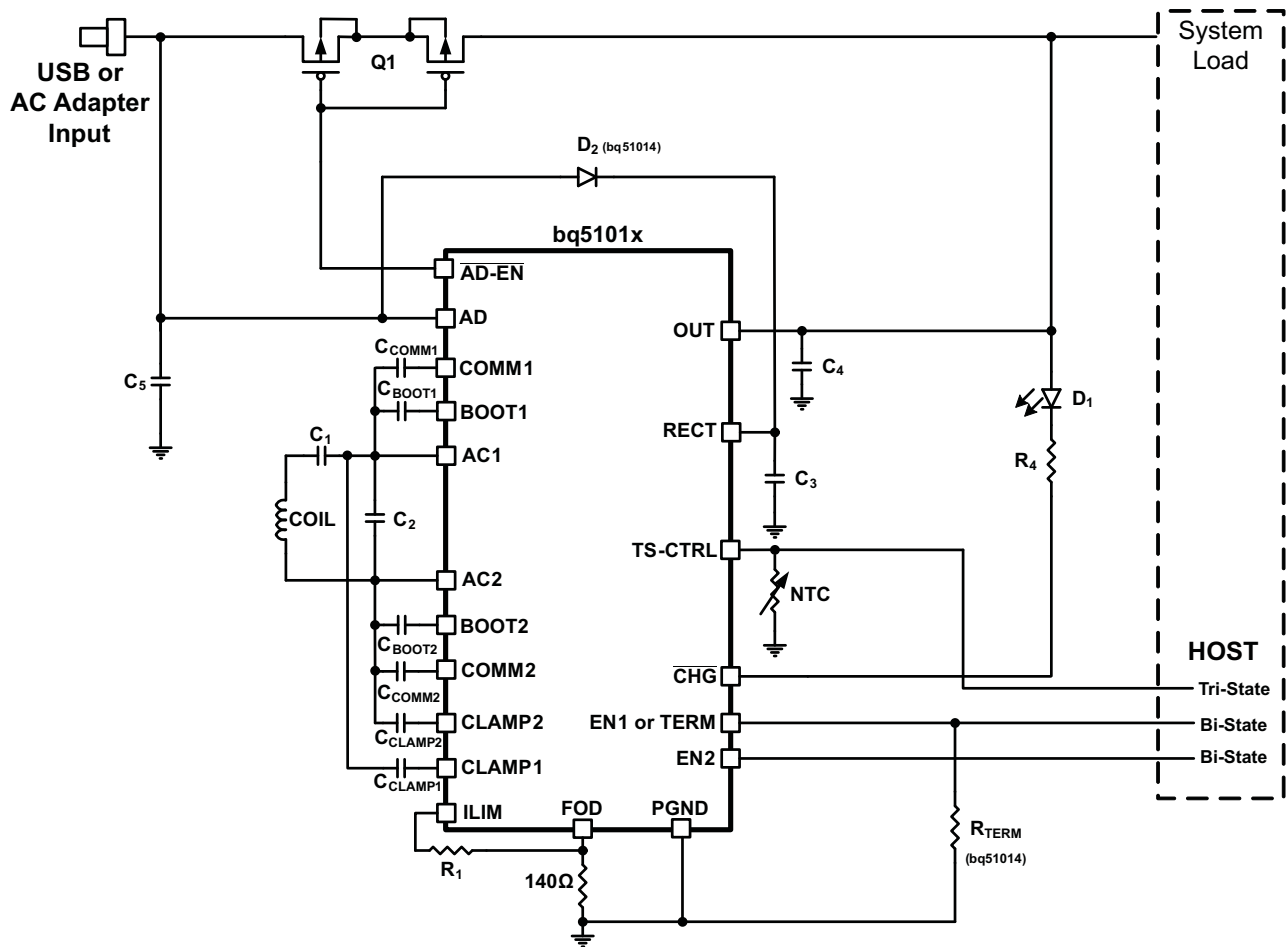

Figure 3. bq5101x Used as a Wireless Power Receiver and Power Supply for System Loads With Adapter Power-Path Multiplexing

**bq51013A  
bq51014**

SLUSAY6B – MARCH 2012 – REVISED OCTOBER 2013

www.ti.com

**ELECTRICAL CHARACTERISTICS**
over operating free-air temperature range,  $-40^{\circ}\text{C}$  to  $125^{\circ}\text{C}$  (unless otherwise noted)

PARAMETER		TEST CONDITIONS	MIN	TYP	MAX	UNIT
UVLO	Undervoltage lock-out	$V_{\text{RECT}}: 0\text{V} \rightarrow 3\text{V}$	2.5	2.7	2.8	V
$V_{\text{HYS}}$	Hysteresis on UVLO	$V_{\text{RECT}}: 3\text{V} \rightarrow 2\text{V}$		250		mV
	Hysteresis on OVP	$V_{\text{RECT}}: 16\text{V} \rightarrow 5\text{V}$		150		mV
$V_{\text{RECT}}$	Input overvoltage threshold	$V_{\text{RECT}}: 5\text{V} \rightarrow 16\text{V}$	14.5	15	15.5	V
$V_{\text{RECT-REG}}$	Dynamic $V_{\text{RECT}}$ Threshold 1	$I_{\text{LOAD}} < 0.1 \times I_{\text{LIM}}$ ( $I_{\text{LOAD}}$ rising)		7.08		V
	Dynamic $V_{\text{RECT}}$ Threshold 2	$0.1 \times I_{\text{LIM}} < I_{\text{LOAD}} < 0.2 \times I_{\text{LIM}}$ ( $I_{\text{LOAD}}$ rising)		6.28		
	Dynamic $V_{\text{RECT}}$ Threshold 3	$0.2 \times I_{\text{LIM}} < I_{\text{LOAD}} < 0.4 \times I_{\text{LIM}}$ ( $I_{\text{LOAD}}$ rising)		5.53		
	Dynamic $V_{\text{RECT}}$ Threshold 4	$I_{\text{LOAD}} > 0.4 \times I_{\text{LIM}}$ ( $I_{\text{LOAD}}$ rising)		5.11		
$I_{\text{LOAD}}$	$I_{\text{LOAD}}$ Hysteresis for dynamic $V_{\text{RECT}}$ thresholds as a % of $I_{\text{LIM}}$	$I_{\text{LOAD}}$ falling		4%		
$V_{\text{RECT-DPM}}$	Rectifier undervoltage protection, restricts $I_{\text{OUT}}$ at $V_{\text{RECT-DPM}}$		3	3.1	3.2	V
$V_{\text{RECT-REV}}$	Rectifier reverse voltage protection at the output	$V_{\text{RECT-REV}} = V_{\text{OUT}} - V_{\text{RECT}}$ , $V_{\text{OUT}} = 10\text{V}$		8	9	V
<b>Quiescent Current</b>						
$I_{\text{RECT}}$	Active chip quiescent current consumption from RECT	$I_{\text{LOAD}} = 0\text{ mA}$ , $0^{\circ}\text{C} \leq T_{\text{J}} \leq 85^{\circ}\text{C}$		8	10	mA
		$I_{\text{LOAD}} = 300\text{ mA}$ , $0^{\circ}\text{C} \leq T_{\text{J}} \leq 85^{\circ}\text{C}$		2	3.0	mA
$I_{\text{OUT}}$	Quiescent current at the output when wireless power is disabled (Standby)	$V_{\text{OUT}} = 5\text{ V}$ , $0^{\circ}\text{C} \leq T_{\text{J}} \leq 85^{\circ}\text{C}$		20	35	$\mu\text{A}$
<b><math>I_{\text{LIM}}</math> Short Circuit</b>						
$R_{\text{ILIM}}$	Highest value of $I_{\text{LIM}}$ resistor considered a fault (short). Monitored for $I_{\text{OUT}} > 100\text{ mA}$	$R_{\text{ILIM}}: 200\Omega \rightarrow 50\Omega$ . $I_{\text{OUT}}$ latches off, cycle power to reset			120	$\Omega$
$t_{\text{DGL}}$	Deglint time transition from $I_{\text{LIM}}$ short to $I_{\text{OUT}}$ disable			1		ms
$I_{\text{LIM\_SC}}$	$I_{\text{LIM\_SHORT\_OK}}$ enables the $I_{\text{LIM}}$ short comparator when $I_{\text{OUT}}$ is greater than this value	$I_{\text{LOAD}}: 0 \rightarrow 20\text{ mA}$	120	145	165	mA
	Hysteresis for $I_{\text{LIM\_SHORT\_OK}}$ comparator	$I_{\text{LOAD}}: 0 \rightarrow 200\text{ mA}$		30		mA
$I_{\text{OUT}}$	Maximum output current limit, $C_{\text{L}}$	Maximum $I_{\text{LOAD}}$ that will be delivered for 1 ms when $I_{\text{LIM}}$ is shorted			2.4	A
<b>OUTPUT</b>						
$V_{\text{OUT-REG}}$	Regulated output voltage	$I_{\text{LOAD}} = 1000\text{ mA}$	4.82	4.95	5	V
		$I_{\text{LOAD}} = 10\text{ mA}$	4.92	5	5.05	
$K_{\text{ILIM}}$	Current programming factor for hardware short circuit protection	$R_{\text{LIM}} = K_{\text{ILIM}} / I_{\text{LIM}}$ , where $I_{\text{LIM}}$ is the hardware current limit. $I_{\text{OUT}} = 1\text{ A}$	280	300	320	$\text{A}\Omega$
$K_{\text{IMAX}}$	Current programming factor for the nominal operating current	$I_{\text{IMAX}} = K_{\text{IMAX}} / R_{\text{LIM}}$ where $I_{\text{MAX}}$ is the maximum normal operating current. $I_{\text{OUT}} = 1\text{ A}$	230	250	270	$\text{A}\Omega$
$I_{\text{OUT}}$	Current limit programming range				1500	mA
$I_{\text{COMM}}$	Current limit during WPC communication	$I_{\text{OUT}} > 300\text{ mA}$		$I_{\text{OUT}} + 50$		mA
		$I_{\text{OUT}} < 300\text{ mA}$	350	390	435	mA
$t_{\text{HOLD}}$	Hold off time for the communication current limit during startup			1		s

**ELECTRICAL CHARACTERISTICS (continued)**

over operating free-air temperature range, –40°C to 125°C (unless otherwise noted)

PARAMETER		TEST CONDITIONS	MIN	TYP	MAX	UNIT
<b>TERMINATION (Charge Status 100%) – bq51014 ONLY</b>						
$K_{TERM}$	Programmable termination factor as a percentage of $I_{MAX}$	$R_{TERM} = \%I_{MAX} \times K_{TERM}$	160	200	240	$\Omega/\%$
$I_{TERM}$	High termination current threshold calculation	$I_{TERM-HI} = (R_{TERM} / K_{TERM}) \times 0.01 \times I_{MAX}$ , where $I_{MAX} = K_{IMAX} / R_{ILIM}$				
	Low termination current threshold			25		mA
	Constant current at the TERM pin to bias the termination resistor	$V_{TERM} = 0\text{ V}$	48	51	54	$\mu\text{A}$
$t_{TERM}$	High termination threshold deglitch	$I_{TERM-LOW} < I_{OUT} < I_{TERM-HI}$		180		sec
	High termination threshold deglitch	$I_{OUT} < I_{TERM-LOW}$		7		sec
<b>TS / CTRL</b>						
$V_{TS}$	Internal TS Bias Voltage	$I_{TS-Bias} < 100\ \mu\text{A}$ (periodically driven see $t_{TS-CTRL}$ )	2	2.2	2.4	V
$V_{COLD}$	Rising threshold	$V_{TS}: 50\% \rightarrow 60\%$	56.5	58.7	60.8	% $V_{TS-Bias}$
	Falling hysteresis	$V_{TS}: 60\% \rightarrow 50\%$		1		
$V_{HOT}$	Falling threshold	$V_{TS}: 20\% \rightarrow 15\%$	18.5	19.6	20.7	
	Rising hysteresis	$V_{TS}: 15\% \rightarrow 20\%$		1		
$V_{CTRL}$	CTRL pin threshold for a high	$V_{TS/CTRL}: 50 \rightarrow 150\text{mV}$	80	100	130	mV
	CTRL pin threshold for a low	$V_{TS/CTRL}: 150 \rightarrow 50\text{mV}$	50	80	100	mV
$t_{TS-CTRL}$	Time $V_{TS-Bias}$ is active when TS measurements occur	Synchronous to the communication period		24		ms
$t_{TS}$	Deglitch time for all TS comparators			10		ms
$R_{TS}$	Pull-up resistor for the NTC network. Pulled up to the voltage bias		18	20	22	k $\Omega$
<b>THERMAL PROTECTION</b>						
$T_J$	Thermal shutdown temperature			155		$^{\circ}\text{C}$
	Thermal shutdown hysteresis			20		$^{\circ}\text{C}$
<b>OUTPUT LOGIC LEVELS ON <math>\overline{\text{WPG}}</math></b>						
$V_{OL}$	Open drain $\overline{\text{WPG}}$ pin	$I_{SINK} = 5\text{ mA}$			500	mV
$I_{OFF}$	$\overline{\text{WPG}}$ leakage current when disabled	$V_{CHG} = 20\text{ V}$			1	$\mu\text{A}$
<b>COMM PIN</b>						
$R_{DS(ON)}$	COM1 and COM2	$V_{RECT} = 2.6\text{ V}$		1.5		$\Omega$
$f_{COMM}$	Signaling frequency on COMM pin			2.00		Kb/s
$I_{OFF}$	Comm pin leakage current	$V_{COM1} = 20\text{ V}, V_{COM2} = 20\text{ V}$			1	$\mu\text{A}$
<b>CLAMP PIN</b>						
$R_{DS(ON)}$	Clamp1 and Clamp2			1		$\Omega$
<b>Adapter Enable</b>						
$V_{AD-EN}$	$V_{AD}$ Rising threshold voltage. EN-UVLO	$V_{AD} 0 \rightarrow 5\text{ V}$	3.5	3.6	3.8	V
	$V_{AD-EN}$ hysteresis, EN-HYS	$V_{AD} 5 \rightarrow 0\text{ V}$		400		mV
$I_{AD}$	Input leakage current	$V_{RECT} = 0\text{V}, V_{AD} = 5\text{V}$			60	$\mu\text{A}$
$V_{AD-OVP}$	Adapter mode OVP threshold rising edge	bq51014 $V_{AD} 10 \rightarrow 15\text{ V}$	12	12.5	13	V
	$V_{AD-OVP}$ hysteresis	$V_{AD} 15 \rightarrow 10\text{ V}$		0.5		V
$R_{AD}$	Pull-up resistance from $\overline{\text{AD-EN}}$ to OUT when adapter mode is disabled and $V_{OUT} > V_{AD}$ , EN-OUT	$V_{AD} = 0, V_{OUT} = 5$		200	350	$\Omega$
$V_{AD}$	Voltage difference between $V_{AD}$ and $V_{AD-EN}$ when adapter mode is enabled, EN-ON	$V_{AD} = 5\text{ V}, 0^{\circ}\text{C} \leq T_J \leq 85^{\circ}\text{C}$	3	4.5	5	V

**bq51013A**  
**bq51014**

SLUSAY6B – MARCH 2012 – REVISED OCTOBER 2013

www.ti.com

**ELECTRICAL CHARACTERISTICS (continued)**
over operating free-air temperature range,  $-40^{\circ}\text{C}$  to  $125^{\circ}\text{C}$  (unless otherwise noted)

PARAMETER		TEST CONDITIONS	MIN	TYP	MAX	UNIT
<b>Synchronous Rectifier</b>						
$I_{\text{OUT}}$	$I_{\text{OUT}}$ at which the synchronous rectifier enters half synchronous mode, SYNC_EN	$I_{\text{LOAD}} 200 \rightarrow 0 \text{ mA}$	80	100	125	mA
	Hysteresis for $I_{\text{OUT,RECT-EN}}$ (full-synchronous mode enabled)	$I_{\text{LOAD}} 0 \rightarrow 200 \text{ mA}$		25		mA
$V_{\text{HS-DIODE}}$	High-side diode drop when the rectifier is in half synchronous mode	$I_{\text{AC-VRECT}} = 250 \text{ mA}$ and $T_{\text{J}} = 25^{\circ}\text{C}$		0.7		V
<b>EN1 and EN2</b>						
$V_{\text{IL}}$	Input low threshold for EN1 and EN2				0.4	V
$V_{\text{IH}}$	Input high threshold for EN1 and EN2		1.3			V
$R_{\text{PD}}$	EN1 and EN2 pull down resistance			200		k $\Omega$
<b>ADC (WPC Related Measurements and Coefficients)</b>						
$P_{\text{RECT}}$	Rectified power accuracy as a percentage of output power	0W – 5W of rectified power		$\pm 6$		%

DEVICE INFORMATION  
SIMPLIFIED BLOCK DIAGRAM

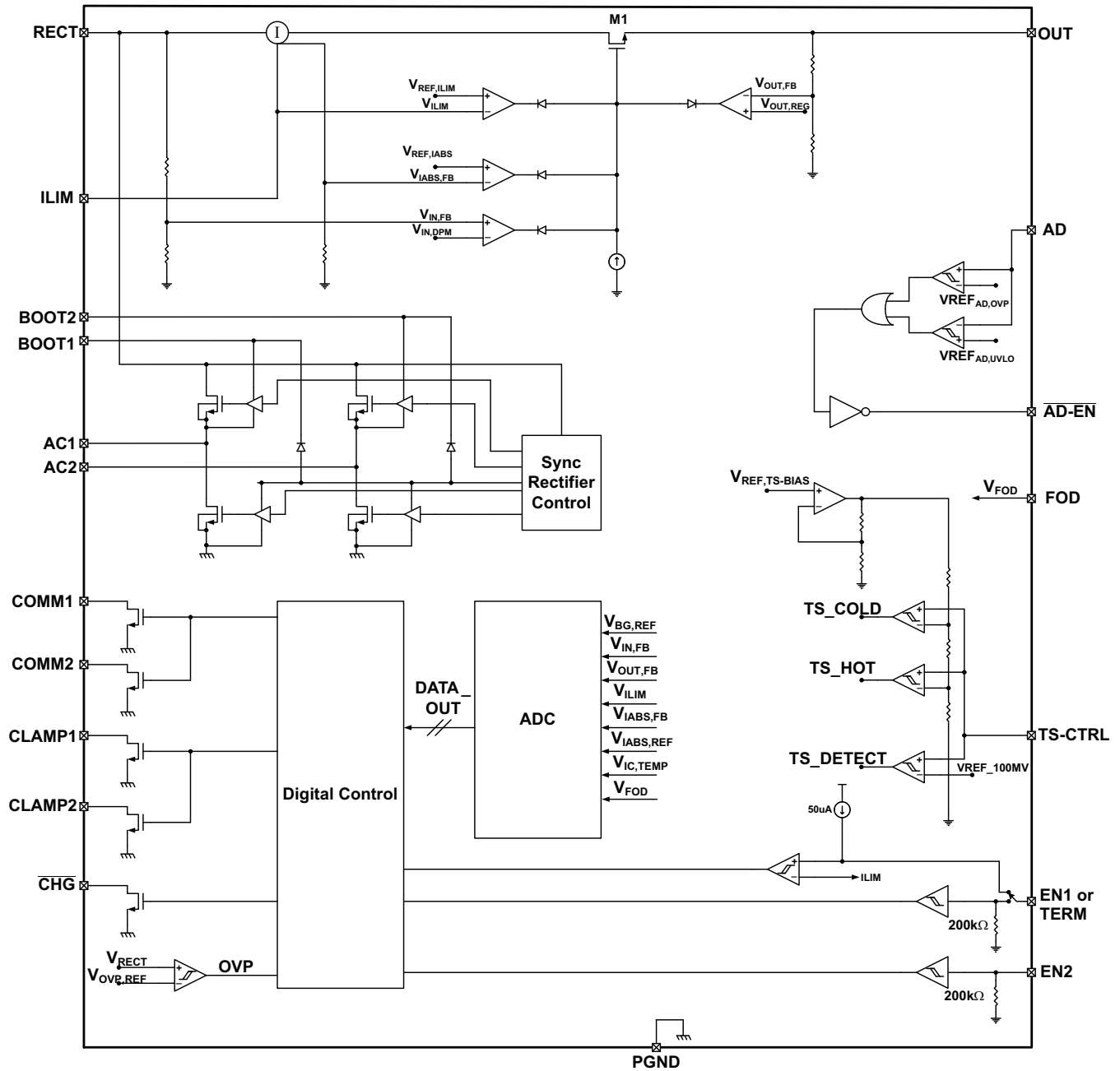

**YFP Package  
(TOP VIEW)**

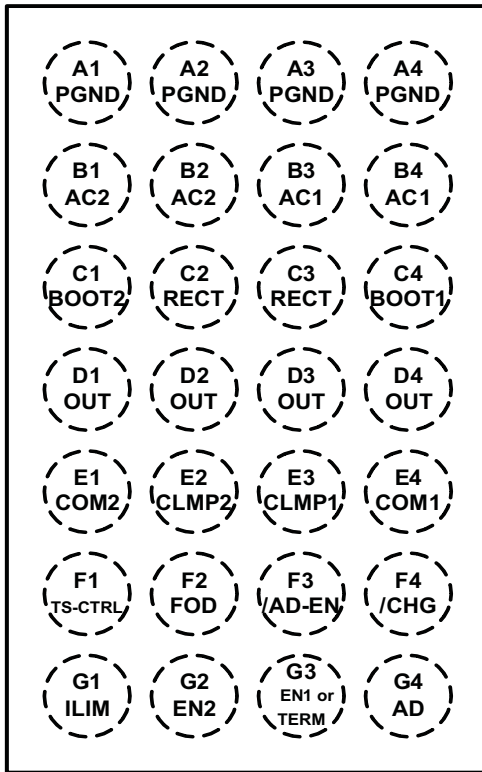

**RHL Package  
(TOP VIEW)**

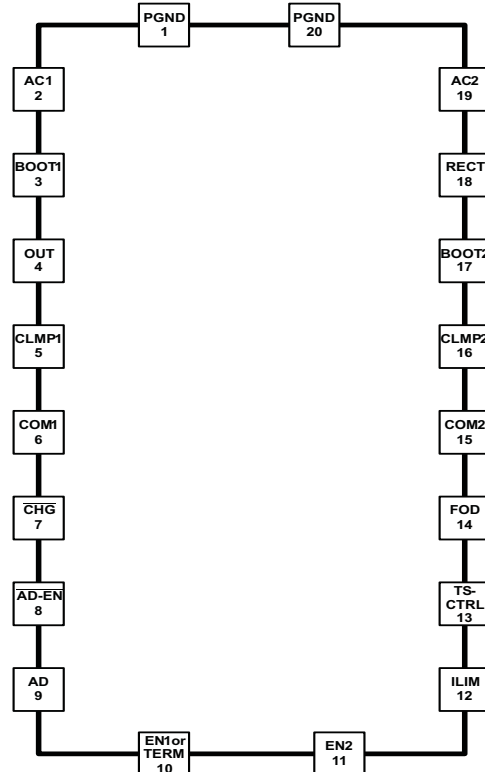

**PIN FUNCTIONS**

NAME	YFP	RHL	I/O	DESCRIPTION
AC1	B3, B4	2	I	AC input from receiver coil antenna.
AC2	B1, B2	19	I	
BOOT1	C4	3	O	Bootstrap capacitors for driving the high-side FETs of the synchronous rectifier. Connect a 10 nF ceramic capacitor from BOOT1 to AC1 and from BOOT2 to AC2.
BOOT2	C1	17	O	
RECT	C2, C3	18	O	Filter capacitor for the internal synchronous rectifier. Connect a ceramic capacitor to PGND. Depending on the power levels, the value may be 4.7 μF to 22 μF.
OUT	D1, D2, D3, D4	4	O	Output pin, delivers power to the load.
COM1	E4	6	O	Open-drain output used to communicate with primary by varying reflected impedance. Connect through a capacitor to either AC1 or AC2 for capacitive load modulation (COM2 must be connected to the alternate AC1 or AC2 pin). For resistive modulation connect COM1 and COM2 to RECT via a single resistor; connect through separate capacitors for capacitive load modulation.
COM2	E1	15	O	Open-drain output used to communicate with primary by varying reflected impedance. Connect through a capacitor to either AC1 or AC2 for capacitive load modulation (COM1 must be connected to the alternate AC1 or AC2 pin). For resistive modulation connect COM1 and COM2 to RECT via a single resistor; connect through separate capacitors for capacitive load modulation.
CLMP2	E2	16	O	Open drain FETs which are utilized for a non-power dissipative over-voltage AC clamp protection. When the RECT voltage goes above 15 V, both switches will be turned on and the capacitors will act as a low impedance to protect the IC from damage. If used, Clamp1 is required to be connected to AC1, and Clamp2 is required to be connected to AC2 via 0.47μF capacitors.
CLMP1	E3	5	O	
PGND	A1, A2, A3, A4	1, 20		Power ground

**PIN FUNCTIONS (continued)**

NAME	YFP	RHL	I/O	DESCRIPTION
ILIM	G1	12	I/O	Programming pin for the over current limit. Connect external resistor to VSS. Size $R_{ILIM}$ with the following equation: $R_{ILIM} = 250 / I_{MAX}$ where $I_{MAX}$ is the expected maximum output current of the wireless power supply. The hardware current limit (ILIM) will be 20% greater than $I_{MAX}$ or $1.2 \times I_{MAX}$ . If the supply is meant to operate in current limit use $R_{ILIM} = 300 / I_{ILIM}$ $R_{ILIM} = R1 + 140$
AD	G4	9	I	Connect this pin to the wired adapter input. When a voltage is applied to this pin wireless charging is disabled and AD_EN is driven low. Connect to GND through a 1 $\mu$ F capacitor. If unused, capacitor is not required and should be grounded directly. For the bq51014, there is an OVP protection of 12.5 V. If the AD voltage is greater than 12.5 V, wireless charging will remain active.
$\overline{AD-EN}$	F3	8	O	Push-pull driver for external PFET connecting AD and OUT. This node is pulled to the higher of OUT and AD when turning off the external FET. This voltage tracks approximately 4 V below AD when voltage is present at AD and provides a regulated VSG bias for the external FET. Float this pin if unused.
TS-CTRL	F1	13	I	Must be connected to ground via a resistor. If an NTC function is not desired connect to GND with a 10 k $\Omega$ resistor. As a CTRL pin pull to ground to send end power transfer (EPT) fault to the transmitter or pull-up to an internal rail (i.e. 1.8 V) to send EPT termination to the transmitter. Note that a 3-state driver should be used to interface this pin (see the <a href="#">3-state Driver</a> section for further description)
EN1	G3	10	I	Inputs that allow user to enable/disable wireless and wired charging <EN1 EN2>: <00> wireless charging is enabled unless AD voltage > 3.6 V <01> Dynamic communication current limit disabled <10> AD-EN pulled low, wireless charging disabled <11> wired and wireless charging disabled.
EN2	G2	11	I	
TERM	G3	10	I	Input that allows allows the upper termination threshold ( $I_{TERM-HI}$ ) to be programmable. $K_{TERM} = 200 \Omega/\%$ . Set the termination threshold by applying the following equation $R_{TERM} = \%I_{MAX} \times K_{TERM}$ where $\%I_{MAX}$ is the desired percentage of the maximum output current when termination should occur (i.e. 10% of 1 A = 0.1 mA)
FOD	F2	14	O	Input for the rectified power measurement. Connect to GND with a 140 $\Omega$ resistor
$\overline{CHG}$	F4	7	O	Open-drain output – active when output current is being delivered to the load (i.e. when the output of the supply is enabled).

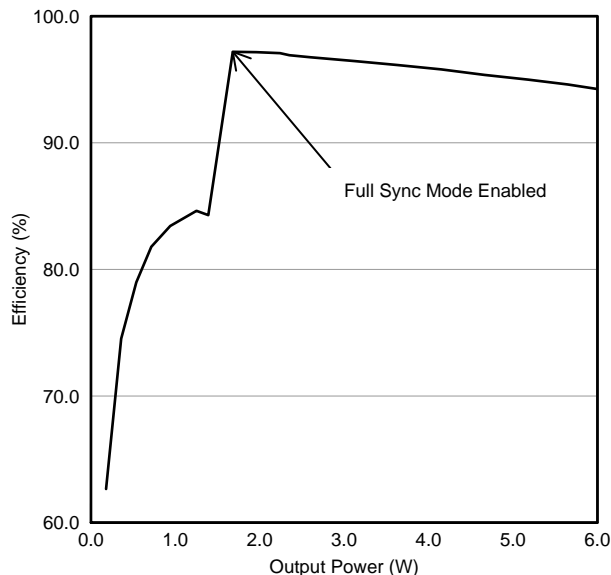
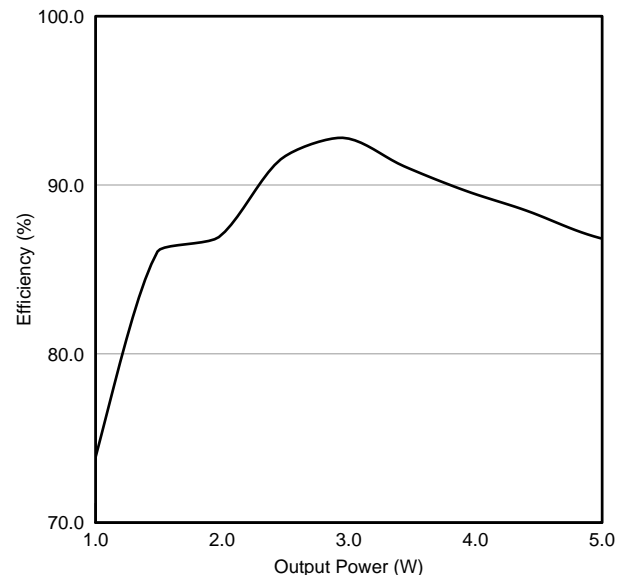
**TYPICAL CHARACTERISTICS**

**Figure 4. Rectifier Efficiency**

**Figure 5. IC Efficiency from AC Input to DC Output**

TYPICAL CHARACTERISTICS (continued)

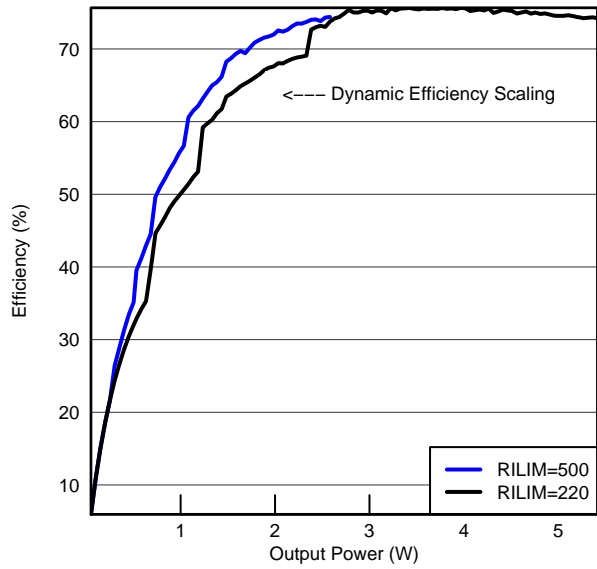

Figure 6. Light Load Efficiency Improvement due to Dynamic Efficiency Scaling Feature(1)

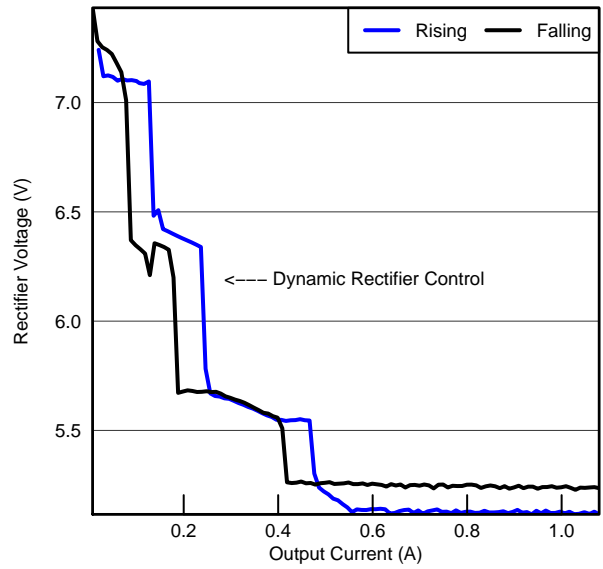

Figure 7.  $V_{RECT}$  vs.  $I_{LOAD}$  at  $R_{ILIM} = 220\Omega$

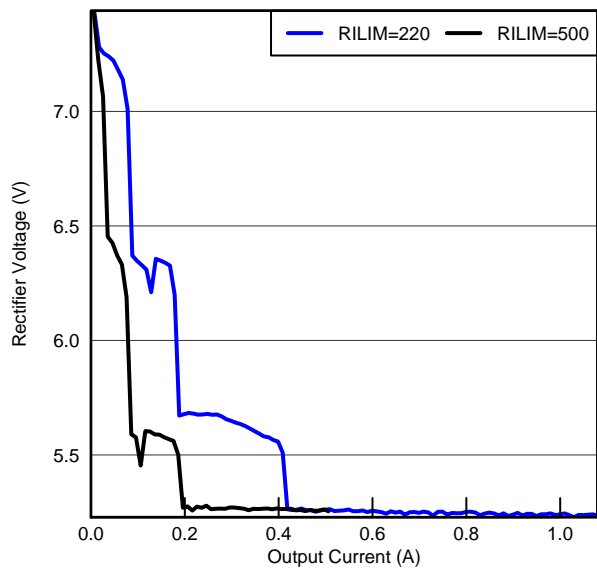

Figure 8.  $V_{RECT}$  vs.  $I_{LOAD}$  at  $R_{ILIM} = 220\Omega$  and  $500\Omega$

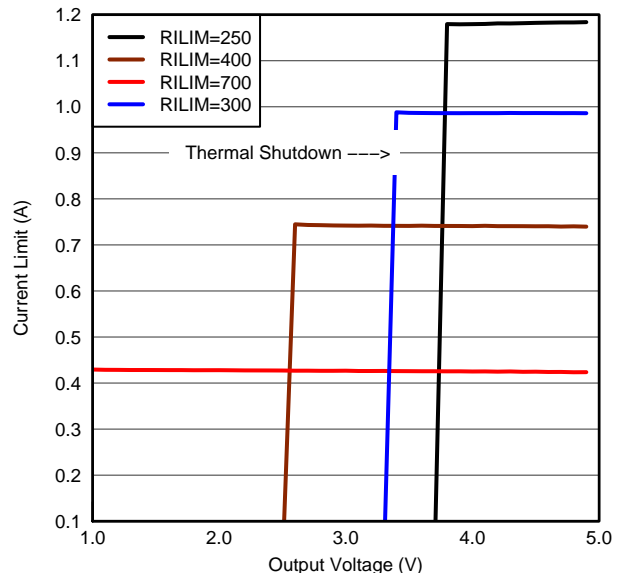

Figure 9.  $V_{OUT}$  Sweep (I-V Curve)(2)

TYPICAL CHARACTERISTICS (continued)

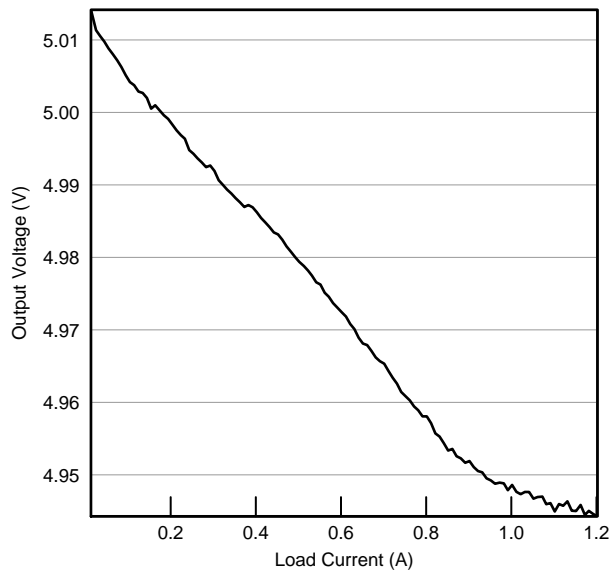

Figure 10. I<sub>LOAD</sub> Sweep (I-V Curve)

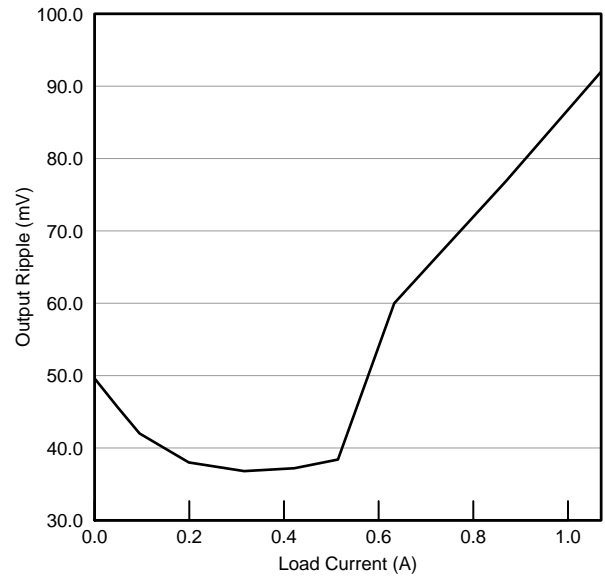

Figure 11. Output Ripple vs. I<sub>LOAD</sub> (C<sub>OUT</sub> = 1µF)

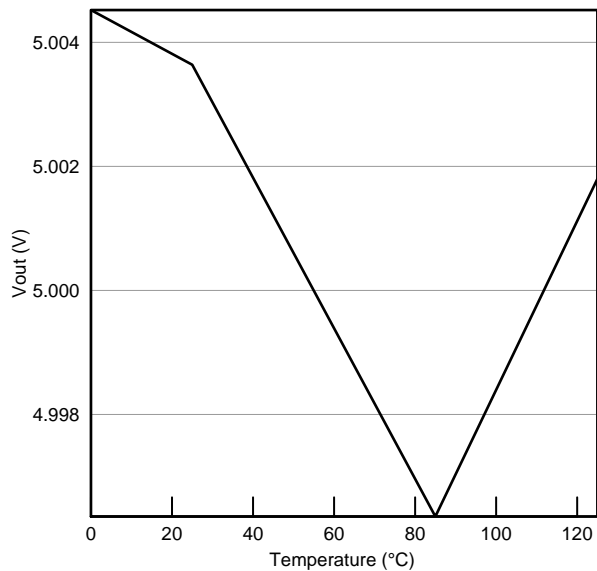

Figure 12. V<sub>OUT</sub> vs Temperature

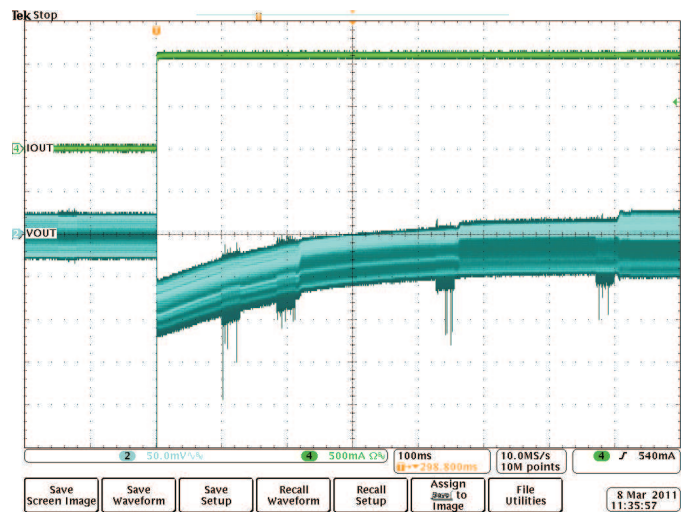

Figure 13. 1A Instantaneous Load Step(3)

**TYPICAL CHARACTERISTICS (continued)**

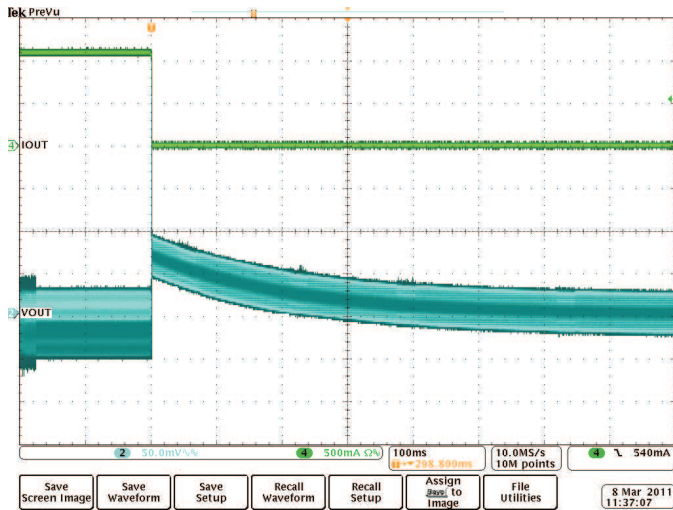

Figure 14. 1A Instantaneous Load Dump(3)

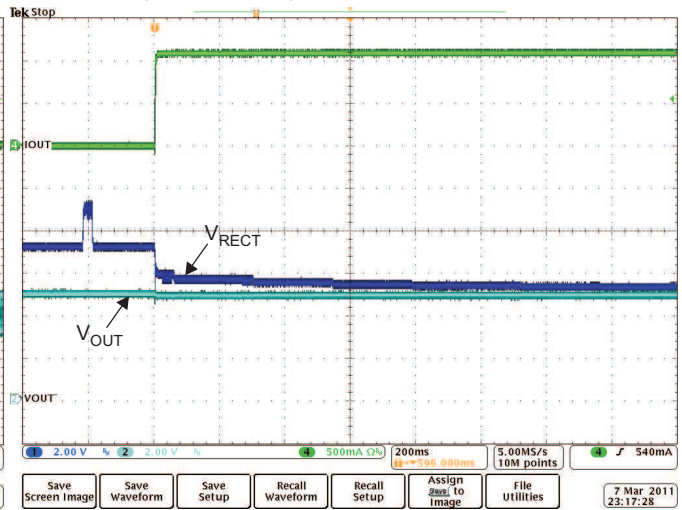

Figure 15. 1A Load Step Full System Response

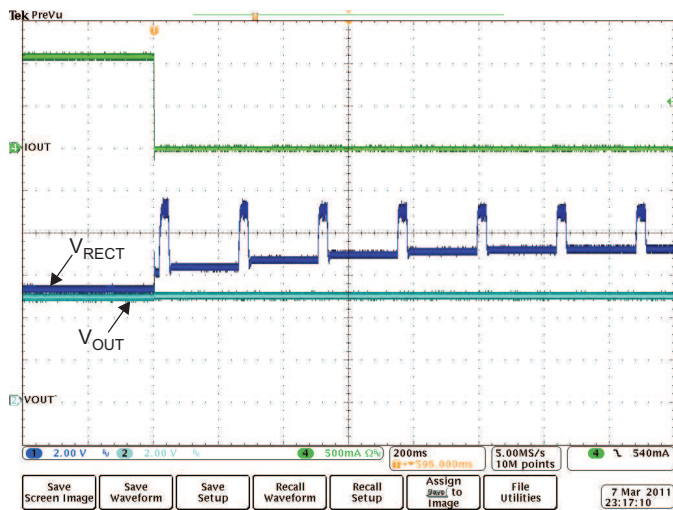

Figure 16. 1A Load Dump Full System Response

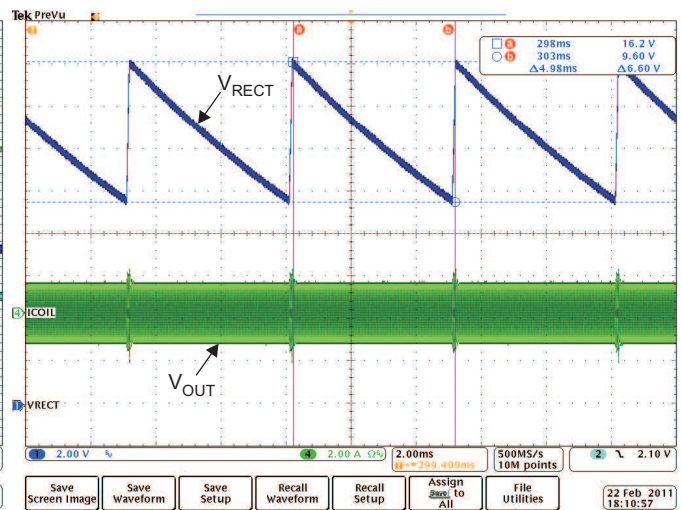

Figure 17. Rectifier Overvoltage Clamp ( $f_{op} = 110\text{kHz}$ )

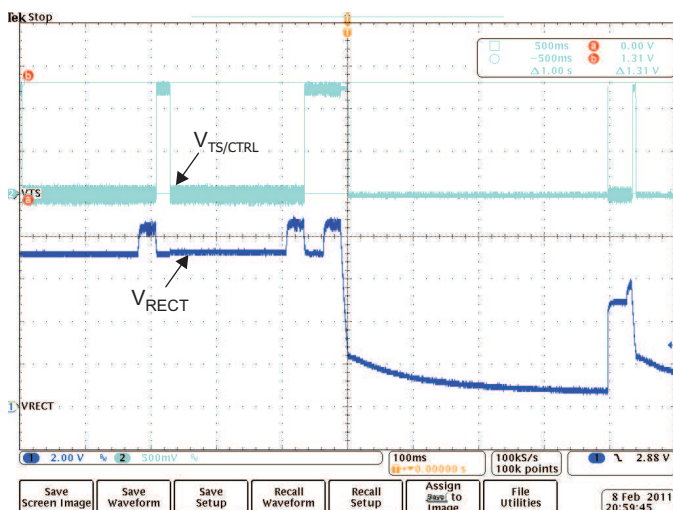

Figure 18. TS Fault

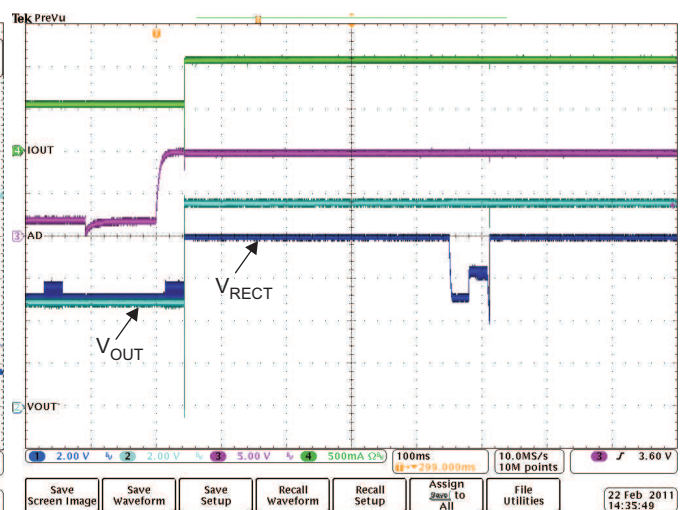

Figure 19. Adapter Insertion ( $V_{AD} = 10\text{V}$ )

TYPICAL CHARACTERISTICS (continued)

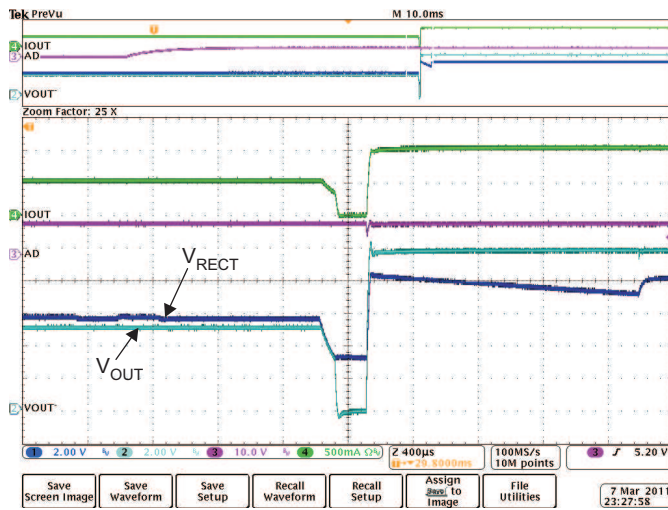

Figure 20. Adapter Insertion ( $V_{AD} = 10V$ ) Illustrating Break-Before-Make Operation

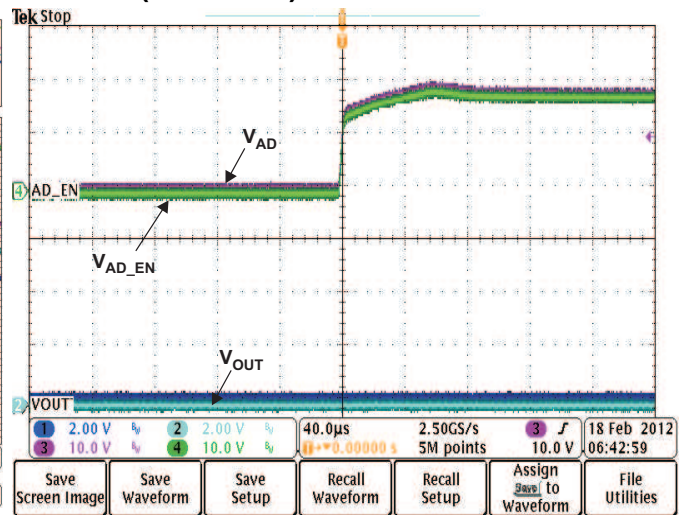

Figure 21. 20V adapter Insertion with AD OVP Enabled (bq51014) and Wireless Power not Present

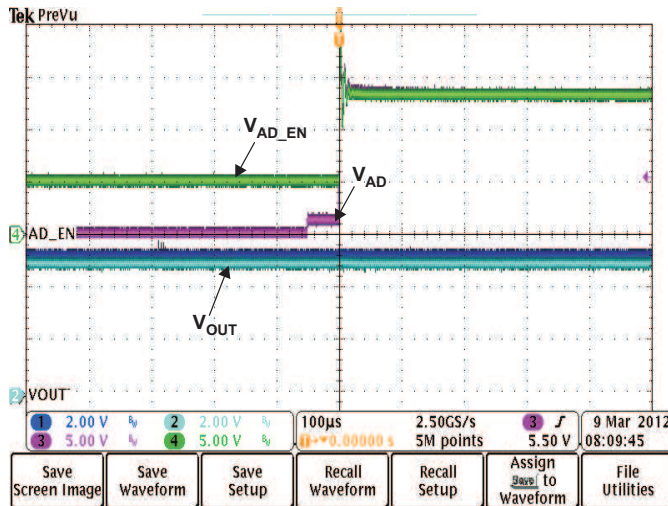

Figure 22. AD OVP Condition While Wireless Charging is Active (bq51014)

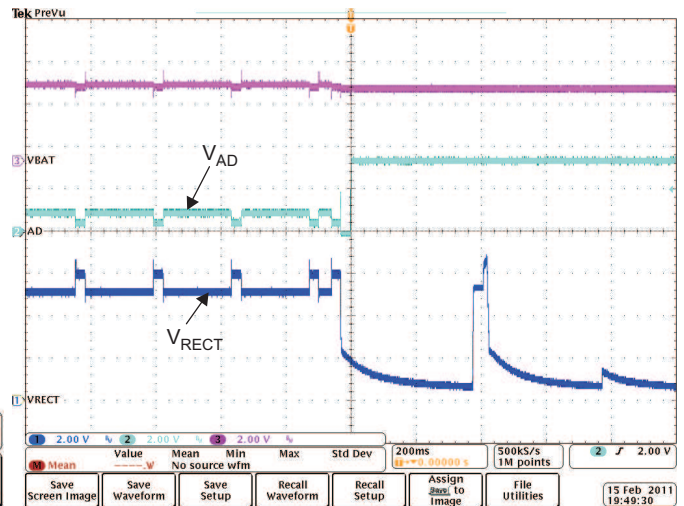
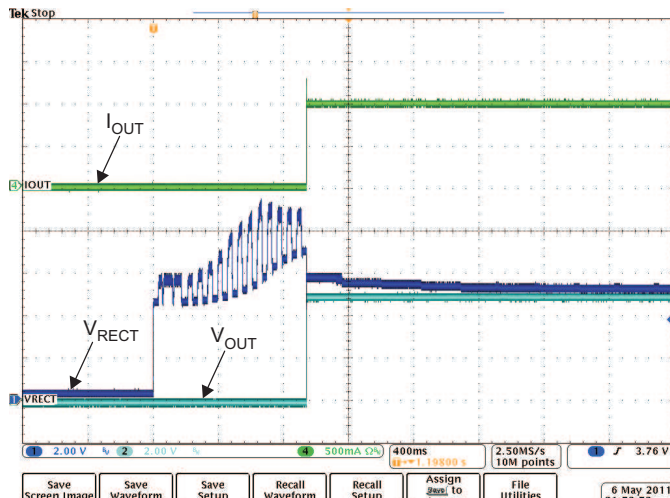
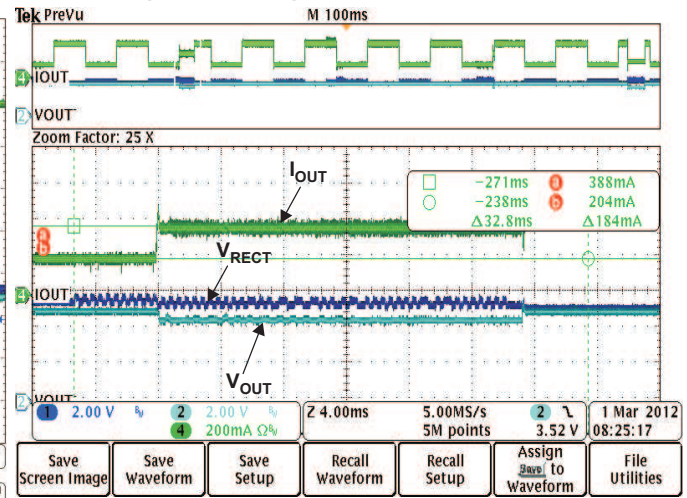

Figure 23. On the Go Enabled ( $V_{OTG} = 3.5V$ )(4)

**TYPICAL CHARACTERISTICS (continued)**



**Figure 24. bq5101x Typical Startup with a 1A System Load**



**Figure 25. Adaptive Communication Limit Event Where the 400 mA Current Limit is Enabled ( $I_{OUT-DC} < 300\text{ mA}$ )**

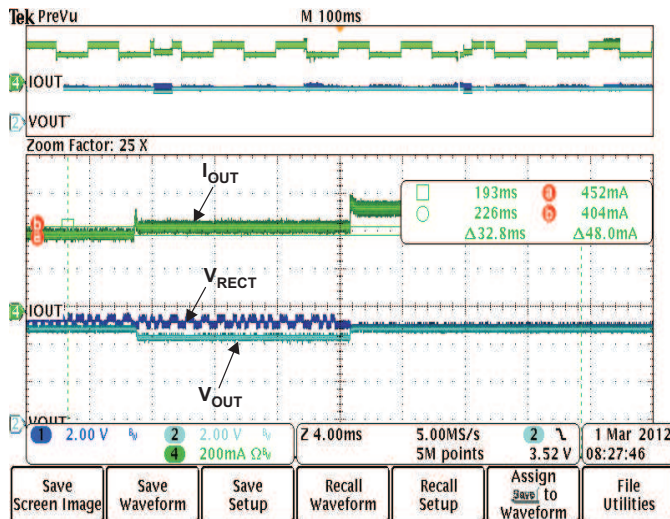

**Figure 26. Adaptive Communication Limit Event Where the Current Limit is  $I_{OUT} + 50\text{ mA}$  ( $I_{OUT-DC} > 300\text{ mA}$ )**

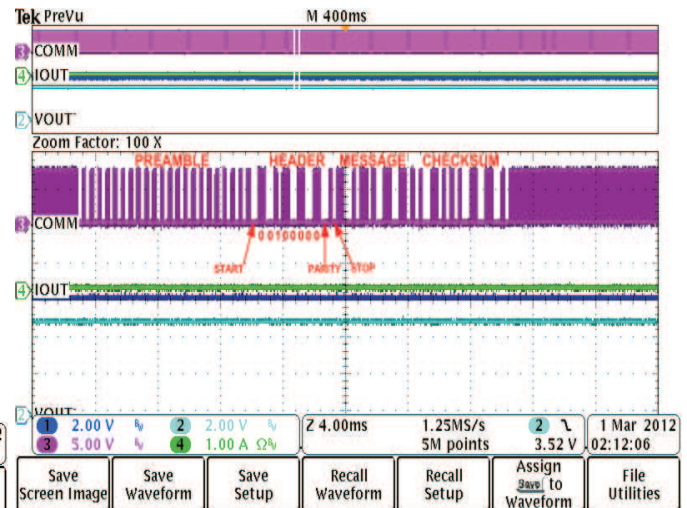

**Figure 27. Rx Communication Packet Structure**

- (1) Efficiency measured from DC input to the transmitter to DC output of the receiver. Transmitter was the bq500210 EVM. Measurement subject to change if an alternate transmitter is used.
- (2) Curves illustrate the resulting  $I_{LIM}$  current by sweeping the output voltage at different  $R_{LIM}$  settings.  $I_{LIM}$  current collapses due to the increasing power dissipation as the voltage at the output is decreased—thermal shutdown is occurring.
- (3) Total droop experienced at the output is dependent on receiver coil design. The output impedance must be low enough at that particular operating frequency in order to not collapse the rectifier below 5V.
- (4) On the go mode is enabled by driving EN1 high. In this test the external PMOS is connected between the output of the bq5101x IC and the AD pin; therefore, any voltage source on the output is supplied to the AD pin.

PRINCIPLE OF OPERATION

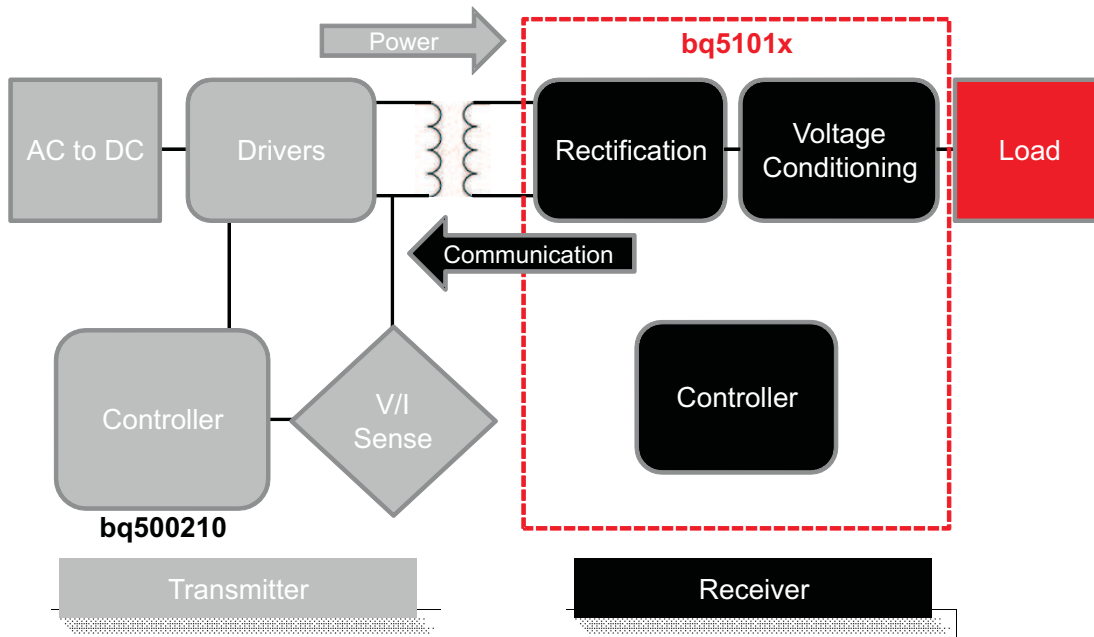

Figure 28. WPC Wireless Power System Indicating the Functional Integration of the bq5101x

**A Brief Description of the Wireless System:**

A wireless system consists of a charging pad (transmitter or primary) and the secondary-side equipment (receiver or secondary). There is a coil in the charging pad and in the secondary equipment which are magnetically coupled to each other when the secondary is placed on the primary. Power is then transferred from the transmitter to the receiver via coupled inductors (e.g. an air-core transformer). Controlling the amount of power transferred is achieved by sending feedback (error signal) communication to the primary (e.g. to increase or decrease power).

The receiver communicates with the transmitter by changing the load seen by the transmitter. This load variation results in a change in the transmitter coil current, which is measured and interpreted by a processor in the charging pad. The communication is digital - packets are transferred from the receiver to the transmitter. Differential Bi-phase encoding is used for the packets. The bit rate is 2-kbps.

Various types of communication packets have been defined. These include identification and authentication packets, error packets, control packets, end power packets, and power usage packets.

The transmitter coil stays powered off most of the time. It occasionally wakes up to see if a receiver is present. When a receiver authenticates itself to the transmitter, the transmitter will remain powered on. The receiver maintains full control over the power transfer using communication packets.

## Using the bq5101x as a Wireless Power Supply: (See [Figure 3](#))

[Figure 3](#) is the schematic of a system which uses the bq5101x as power supply while power multiplexing the wired (adapter) port.

When the system shown in [Figure 3](#) is placed on the charging pad, the receiver coil is inductively coupled to the magnetic flux generated by the coil in the charging pad which consequently induces a voltage in the receiver coil. The internal synchronous rectifier feeds this voltage to the RECT pin which has the filter capacitor C3.

The bq5101x identifies and authenticates itself to the primary using the COM pins by switching on and off the COM FETs and hence switching in and out  $C_{COMM}$ . If the authentication is successful, the transmitter will remain powered on. The bq5101x measures the voltage at the RECT pin, calculates the difference between the actual voltage and the desired voltage  $V_{RECT-REG}$ , (threshold 1 at no load) and sends back error packets to the primary. This process goes on until the input voltage settles at  $V_{RECT-REG}$ . During a load transient, the dynamic rectifier algorithm will set the targets specified by  $V_{RECT-REG}$  thresholds 1, 2, 3, and 4. This algorithm is termed Dynamic Rectifier Control and is used to enhance the transient response of the power supply.

During power-up, the LDO is held off until the  $V_{RECT-REG}$  threshold 1 converges. The voltage control loop ensures that the output voltage is maintained at  $V_{OUT-REG}$  to power the system. The bq5101x meanwhile continues to monitor the input voltage, and maintains sending error packets to the primary every 250ms. If a large transient occurs, the feedback to the primary speeds up to every 32ms in order to converge on an operating point in less time.

## Details of a Qi Wireless Power System and bq5101x Power Transfer Flow Diagrams

The bq5101x family integrates a fully compliant WPC v1.0 communication algorithm in order to streamline receiver designs (no extra software development required). Other unique algorithms such as Dynamic Rectifier Control are also integrated to provide best in class system performance. This section provides a high level overview of these features by illustrating the wireless power transfer flow diagram from startup to active operation.

During startup operation, the wireless power receiver must comply with proper handshaking to be granted a power contract from the Tx. The Tx will initiate the hand shake by providing an extended digital ping. If an Rx is present on the Tx surface, the Rx will then provide the signal strength, configuration and identification packets to the Tx (see volume 1 of the WPC specification for details on each packet). These are the first three packets sent to the Tx. The only exception is if there is a true shutdown condition on the EN1/EN2, AD, or TS-CTRL pins where the Rx will shut down the Tx immediately. See [Table 4](#) for details. Once the Tx has successfully received the signal strength, configuration and identification packets, the Rx will be granted a power contract and is then allowed to control the operating point of the power transfer. With the use of the bq5101x Dynamic Rectifier Control algorithm, the Rx will inform the Tx to adjust the rectifier voltage above 7 V prior to enabling the output supply. This method enhances the transient performance during system startup. See [Figure 29](#) for the startup flow diagram details.

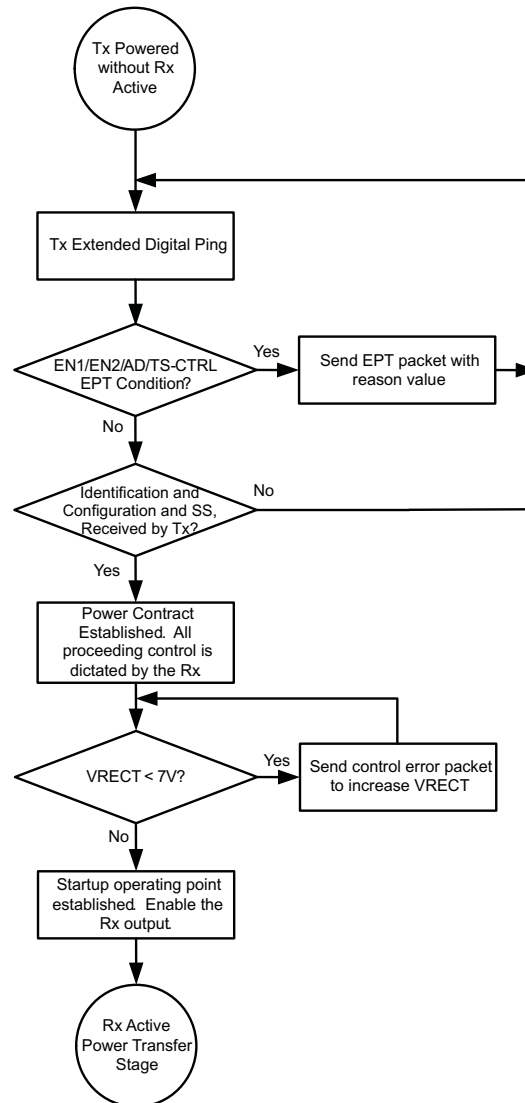
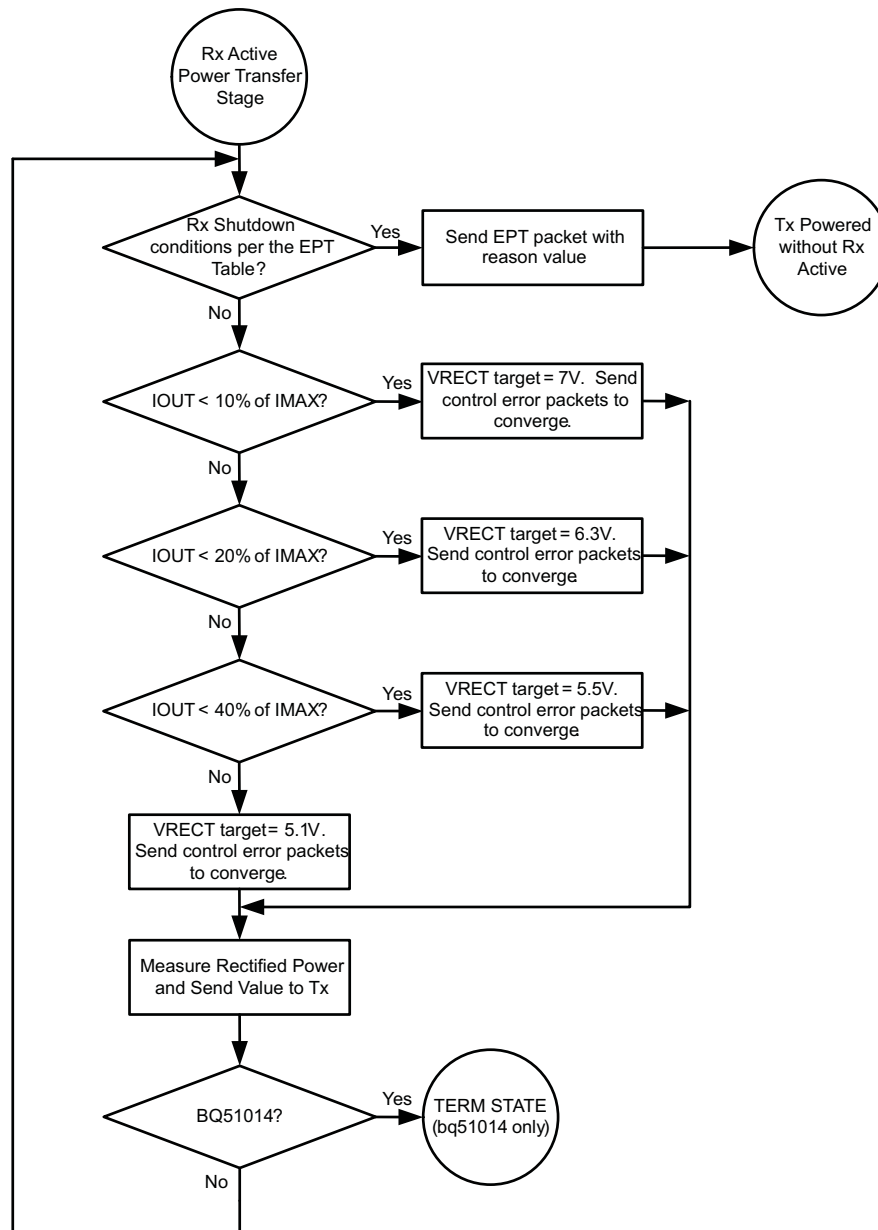

Figure 29. Wireless Power Startup Flow Diagram

Once the startup procedure has been established, the Rx will enter the active power transfer stage. This is considered the “main loop” of operation. The Dynamic Rectifier Control algorithm will determine the rectifier voltage target based on a percentage of the maximum output current level setting (set by  $K_{IMAX}$  and the  $ILIM$  resistance to GND). The Rx will send control error packets in order to converge on these targets. As the output current changes, the rectifier voltage target will dynamically change. As a note, the feedback loop of the WPC system is relatively slow where it can take up to 90 ms to converge on a new rectifier voltage target. It should be understood that the instantaneous transient response of the system is open loop and dependent on the Rx coil output impedance at that operating point. More details on this will be covered in the section Receiver Coil Load-Line Analysis. The “main loop” will also determine if any conditions in Table 4 are true in order to discontinue power transfer. See Figure 30 which illustrates the active power transfer loop.



**Figure 30. Active Power Transfer Flow Diagram**

Another requirement of the WPC v1.0 specification is to send the measured rectifier power. This entitles the Rx to determine the rectifier voltage and output current in order to report this to the Tx as a percentage of the maximum output power. This is also handled in the active power transfer loop.

If the device is a bq51014, a special state called the “TERM STATE” is enabled in the active power transfer loop. This state is used to determine the level of the output current versus the programmed level of termination current (set by the  $K_{TERM}$  factor and  $R_{TERM}$  resistor). The primary purpose of this feature is to determine if the charge status is 100% based on the output current from the Rx. In a condition where the mobile device battery is fully charged, a low system current (output current from Rx) signature can be determined. This current level (signature) is set by the end system designer and is termed  $I_{TERM-HI}$ . In addition to this current level, there is a no-load termination current level termed  $I_{TERM-LO}$  which is fixed at 40 mA. For the high termination condition to be

true, the output current must be between  $I_{\text{TERM-HI}}$  and  $I_{\text{TERM-LO}}$  for approximately 180s. Once this condition is true, the Rx will send charge status of 100% to the Tx. The Tx can then illustrate that the mobile device has been fully charged (100% charged). If the output current remains below  $I_{\text{TERM-LO}}$  for ~7s then the charge status of 100% is immediately sent. This condition can occur if the mobile device is put into a low standby mode after the battery is fully charged. See Figure 31 for the flow diagram of the “TERM STATE”.

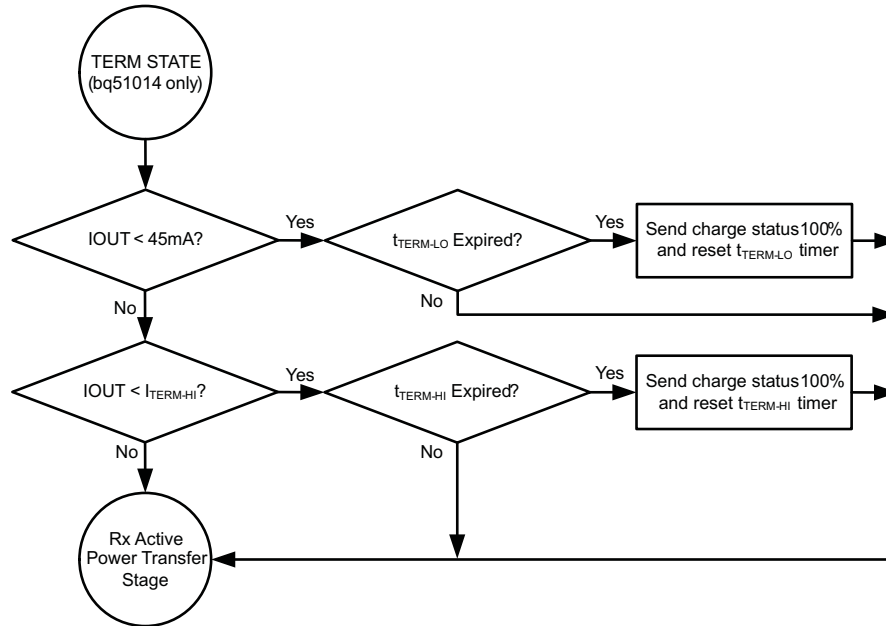

Figure 31. TERM STATE Flow Diagram for the bq51014 Only

### Dynamic Rectifier Control

The Dynamic Rectifier Control algorithm offers the end system designer optimal transient response for a given max output current setting. This is achieved by providing enough voltage headroom across the internal regulator at light loads in order to maintain regulation during a load transient. The WPC system has a relatively slow global feedback loop where it can take up to 90 ms to converge on a new rectifier voltage target. Therefore, a transient response is dependent on the loosely coupled transformers output impedance profile. The Dynamic Rectifier Control allows for a 2 V change in rectified voltage before the transient response will be observed at the output of the internal regulator (output of the bq5101x). A 1-A application allows up to a 2 Ω output impedance. The Dynamic Rectifier Control behavior is illustrated in Figure 7 where  $R_{\text{ILIM}}$  is set to 220 Ω.

### Dynamic Efficiency Scaling

The Dynamic Efficiency Scaling feature allows for the loss characteristics of the bq5101x to be scaled based on the maximum expected output power in the end application. This effectively optimizes the efficiency for each application. This feature is achieved by scaling the loss of the internal LDO based on a percentage of the maximum output current. Note that the maximum output current is set by the  $K_{\text{IMAX}}$  term and the  $R_{\text{ILIM}}$  resistance (where  $R_{\text{ILIM}} = K_{\text{IMAX}} / I_{\text{MAX}}$ ). The flow diagram show in Figure 30 illustrates how the rectifier is dynamically controlled (*Dynamic Rectifier Control*) based on a fixed percentage of the  $I_{\text{MAX}}$  setting. The below table summarizes how the rectifier behavior is dynamically adjusted based on two different  $R_{\text{ILIM}}$  settings.

Table 1.

Output Current Percentage	$R_{\text{ILIM}} = 500\ \Omega$ $I_{\text{MAX}} = 0.5\ \text{A}$	$R_{\text{ILIM}} = 220\ \Omega$ $I_{\text{MAX}} = 1.14\ \text{A}$	$V_{\text{RECT}}$
0 to 10%	0 A to 0.05 A	0 A to 0.114 A	7.08 V
10 to 20%	0.05 A to 0.1A	0.114 A to 0.227 A	6.28 V
20 to 40%	0.1 A to 0.2 A	0.227 A to 0.454 A	5.53 V
>40%	> 0.2 A	> 0.454 A	5.11 V

**bq51013A  
bq51014**

SLUSAY6B – MARCH 2012 – REVISED OCTOBER 2013

www.ti.com

Figure 8 illustrates the shift in the *Dynamic Rectifier Control* behavior based on the two different  $R_{ILIM}$  settings. With the rectifier voltage ( $V_{RECT}$ ) being the input to the internal LDO, this adjustment in the *Dynamic Rectifier Control* thresholds will dynamically adjust the power dissipation across the LDO where:

$$P_{DIS} = (V_{RECT} - V_{OUT}) \times I_{OUT} \quad (1)$$

Figure 6 illustrates how the system efficiency is improved due to the *Dynamic Efficiency Scaling* feature. Note that this feature balances efficiency with optimal system transient response.

### $R_{ILIM}$ Calculations

The bq5101x includes a means of providing hardware overcurrent protection by means of an analog current regulation loop. The hardware current limit provides an extra level of safety by clamping the maximum allowable output current (e.g. a current compliance). The  $R_{ILIM}$  resistor size also set the thresholds for the dynamic rectifier levels and thus providing efficiency tuning per each application's maximum system current. The calculation for the total  $R_{ILIM}$  resistance is as follows:

$$\begin{aligned} R_{ILIM} &= \frac{250}{I_{MAX}} \\ I_{ILIM} &= 1.2 \times I_{MAX} = \frac{300}{R_{ILIM}} \\ R_{ILIM} &= R_1 + 140 \end{aligned} \quad (2)$$

Where  $I_{MAX}$  is the expected maximum output current during normal operation and  $I_{ILIM}$  is the hardware over current limit. When referring to the application diagram shown in Figure 2,  $R_{ILIM}$  is the sum of 140 and the  $R_1$  resistance (e.g. the total resistance from the ILIM pin to GND).

### Termination Calculations (bq51014 only)

The bq51014 includes a programmable upper termination threshold. This pin can be used to send the charge status 100% packet (CS100) to the transmitter in order to indicate a full charge status. The header for this packet is 0x05. Note that this packet does not turn off the transmitter and is only used as an informative indication of the mobile device's charge status. The upper termination threshold is calculated using Equation 3:

$$\begin{aligned} R_{TERM} &= 200 \times \%I_{MAX} \\ \%I_{MAX} &= \frac{I_{TERM-HI} - I_{TERM-LO}}{I_{MAX}} \times 100 \\ I_{MAX} &= \frac{250}{R_{ILIM}} \end{aligned} \quad (3)$$

The 200 constant is specified in the datasheet as  $K_{TERM}$ . The upper termination threshold is set as a percentage of the  $I_{MAX}$  setting. For example, if the ILIM resistance is set to 250  $\Omega$  the  $I_{MAX}$  current will be 1A ( $250 \div 250$ ). If the upper termination threshold is desired to be 100 mA, this would be 10% of  $I_{MAX}$ . The  $R_{TERM}$  resistor would then equal 2k $\Omega$  ( $200 \times 10$ ).

When the output current is in between  $I_{TERM-HI}$  and  $I_{TERM-LO}$ , the CS100 packet is sent approximately every 3 min. When the output current is below  $I_{TERM-LO}$ , the CS100 packet is sent approximately every 7 seconds. The output current must remain in one of the termination conditions for that specific amount of time for the first CS100 packet to be sent (deglitch). See Figure 32 for details:

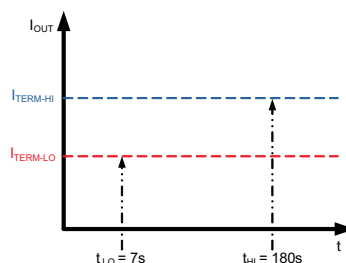

**Figure 32. Termination Deglitch Timings for the CS100 Packet**

## Input Overvoltage

If the input voltage suddenly increases in potential (e.g. a change in position of the equipment on the charging pad), the voltage-control loop inside the bq5101x becomes active, and prevents the output from going beyond  $V_{OUT-REG}$ . The receiver then starts sending back error packets to the transmitter every 30ms until the input voltage comes back to the  $V_{RECT-REG}$  target, and then maintains the error communication every 250ms.

If the input voltage increases in potential beyond  $V_{OVP}$ , the IC switches off the LDO and communicates to the primary to bring the voltage back to  $V_{RECT-REG}$ . In addition, a proprietary voltage protection circuit is activated by means of  $C_{CLAMP1}$  and  $C_{CLAMP2}$  that protects the IC from voltages beyond the maximum rating of the IC (e.g. 20V).

## Adapter Enable Functionality and EN1/EN2 Control

Figure 3 is an example application that shows the bq5101x used as a wireless power receiver that can power multiplex between wired or wireless power for the down-system electronics. In the default operating mode pins EN1 and EN2 are low, which activates the adapter enable functionality. In this mode, if an adapter is not present the AD pin will be low, and AD-EN pin will be pulled to the higher of the OUT and AD pins so that the PMOS between OUT and AD will be turned off. If an adapter is plugged in and the voltage at the AD pin goes above 3.6V then wireless charging is disabled and the AD-EN pin will be pulled approximately 4V below the AD pin to connect AD to the secondary charger. The difference between AD and AD-EN is regulated to a maximum of 7V to ensure the  $V_{GS}$  of the external PMOS is protected.

The EN1 and EN2 pins include internal 200k $\Omega$  pull-down resistors, so that if these pins are not connected bq5101x defaults to AD-EN control mode. However, these pins can be pulled high to enable other operating modes as described in Table 2:

**Table 2.**

EN1	EN2	Result
0	0	Adapter control enabled. If adapter is present then secondary charger is powered by adapter, otherwise wireless charging is enabled when wireless power is available. Communication current limit is enabled.
0	1	Disables communication current limit.
1	0	$\overline{AD-EN}$ is pulled low, whether or not adapter voltage is present. This feature can be used, e.g., for USB OTG applications.
1	1	Adapter and wireless charging are disabled, i.e., power will never be delivered by the OUT pin in this mode.

**Table 3.**

EN1	EN2	Wireless Power	Wired Power	OTG Mode	Adaptive Communication Limit	EPT Termination
0	0	Enabled	Priority <sup>(1)</sup>	Disabled	Enabled	Not Sent to Tx
0	1	Enabled	Priority <sup>(1)</sup>	Disabled	Disabled	Not Sent to Tx
1	0	Disabled	Enabled	Enabled <sup>(2)</sup>	N/A	Sent to Tx
1	1	Disabled	Disabled	Disabled	N/A	Sent to Tx

(1) If both wired and wireless power are present, wired power is given priority.

(2) Allows for a boost-back supply to be driven from the output terminal of the Rx to the adapter port via the external back-to-back PMOS FET.

As described in Table 2, pulling EN2 high disables the adapter mode and only allows wireless charging. In this mode the adapter voltage will always be blocked from the OUT pin. An application example where this mode is useful is when USB power is present at AD, but the USB is in suspend mode so that no power can be taken from the USB supply. Pulling EN1 high enables the off-chip PMOS regardless of the presence of a voltage. This function can be used in USB OTG mode to allow a charger connected to the OUT pin to power the AD pin. Finally, pulling both EN1 and EN2 high disables both wired and wireless charging.

**NOTE**

It is required to connect a back-to-back PMOS between AD and OUT so that voltage is blocked in both directions. Also, when AD mode is enabled no load can be pulled from the RECT pin as this could cause an internal device overvoltage in bq5101x.

**End Power Transfer Packet (WPC Header 0x02)**

The WPC allows for a special command for the receiver to terminate power transfer from the transmitter termed End Power Transfer (EPT) packet. Table 4 specifies the v1.0 Reasons column and their responding data field value. The Condition column corresponds to the values sent by the bq5101x for a given reason.

**Table 4.**

Reason	Value	Condition
Unknown	0x00	AD > 3.6V
Charge Complete	0x01	TS/CTRL = 1, or EN1 = 1, or <EN1 EN2> = <11>
Internal Fault	0x02	$T_J > 150^{\circ}\text{C}$ or $R_{ILIM} < 100\Omega$
Over Temperature	0x03	$TS < V_{HOT}$ , $TS > V_{COLD}$ , or $TS/CTRL < 100\text{mV}$
Over Voltage	0x04	Not Sent
Over Current	0x05	$I_{OUT} > 90\%$ of $I_{LIM}$ (bq51014 only)
Battery Failure	0x06	Not Sent
Reconfigure	0x07	Not Sent
No Response	0x08	VRECT target doesn't converge

**Over Current Shutdown (bq51014)**

The bq51014 includes an over current shutdown feature where the Rx sends an end power transfer packet to the Tx when the output current reaches 100% of the  $I_{LIM}$  setting or 120% of the  $I_{MAX}$  setting. The Tx will shut down as soon as the end power transfer packet is received which discontinues power transfer. This feature disallows the Rx from operating in a current limit situation in order to protect from down system shorts or failures.

**Status Outputs**

bq5101x has one status output,  $\overline{\text{CHG}}$ . This output is an open-drain NMOS device that is rated to 20V. The open-drain FET connected to the  $\overline{\text{CHG}}$  pin will be turned on whenever the output of the power supply is enabled. Please note, the output of the power supply will not be enabled if the  $V_{RECT-REG}$  does not converge at the no-load target voltage.

**WPC Communication Scheme**

The WPC communication uses a modulation technique termed “back-scatter modulation” where the receiver coil is dynamically loaded in order to provide amplitude modulation of the transmitters coil voltage and current. This scheme is possible due to the fundamental behavior between two loosely coupled inductors (e.g. between the Tx and Rx coil). This type of modulation can be accomplished by switching in and out a resistor at the output of the rectifier, or by switching in and out a capacitor across the AC1/AC2 net. Figure 33 shows how to implement resistive modulation.

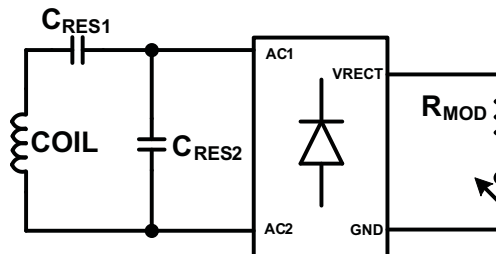

**Figure 33. Resistive Modulation**

Figure 34 Shows how to implement capacitive modulation.

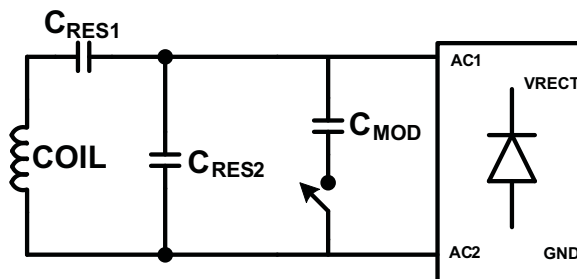

Figure 34. Capacitive Modulation

The amplitude change in Tx coil voltage or current can be detected by the transmitters decoder. The resulting signal observed by the Tx is shown in Figure 35.

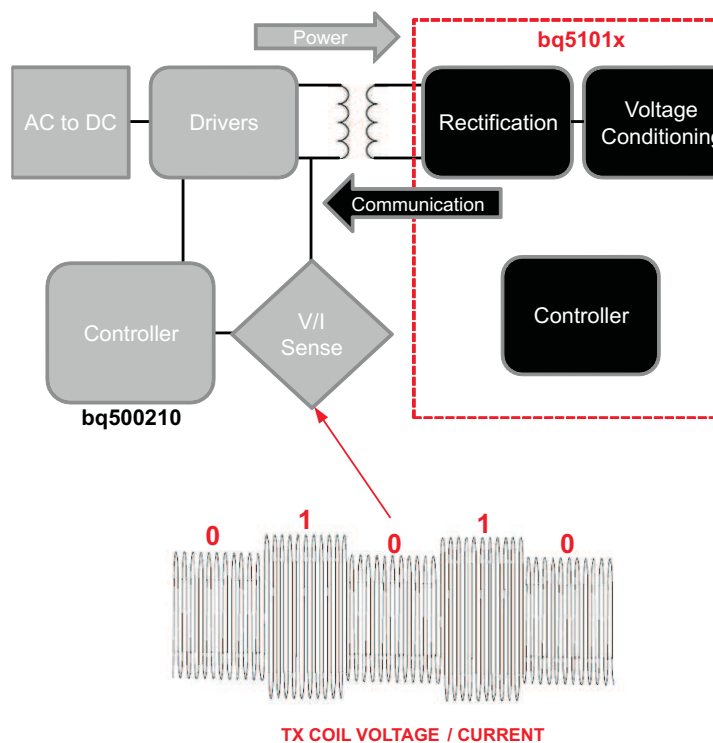
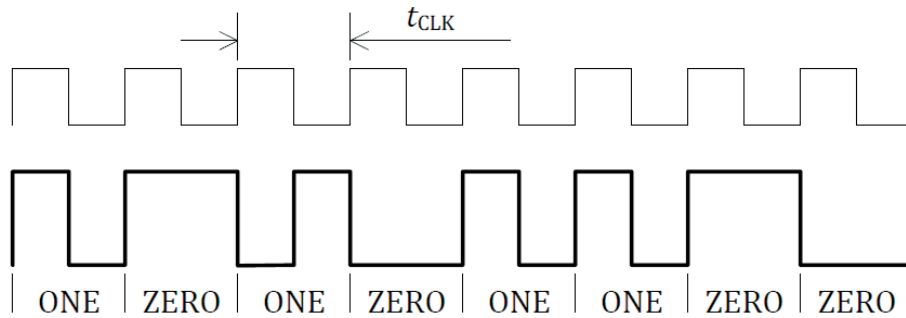

Figure 35.

The WPC protocol uses a differential bi-phase encoding scheme to modulate the data bits onto the Tx coil voltage/current. Each data bit is aligned at a full period of 0.5 ms ( $t_{CLK}$ ) or 2 kHz. An encoded ONE results in two transitions during the bit period and an encoded ZERO results in a single transition. See Figure 36 for an example of the differential bi-phase encoding.



**Figure 36. Differential Bi-phase Encoding Scheme (WPC volume 1: Low Power, Part 1 Interface Definition)**

The bits are sent LSB first and use an 11-bit asynchronous serial format for each portion of the packet. This includes one start bit, n-data bytes, a parity bit, and a single stop bit. The start bit is always ZERO and the parity bit is odd. The stop bit is always ONE. [Figure 37](#) shows the details of the asynchronous serial format.

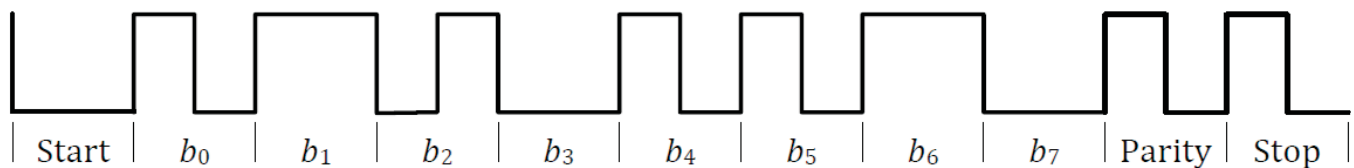

**Figure 37. Asynchronous Serial Formatting (WPC volume 1: Low Power, Part 1 Interface Definition)**

Each packet format is organized as shown in [Figure 38](#).



**Figure 38. Packet Format (WPC volume 1: Low Power, Part 1 Interface Definition)**

[Figure 27](#) above shows an example waveform of the receiver sending a rectified power packet (header 0x04).

### Communication Modulator

bq5101x provides two identical, integrated communication FETs which are connected to the pins COM1 and COM2. These FETs are used for modulating the secondary load current which allows bq5101x to communicate error control and configuration information to the transmitter. [Figure 39](#) below shows how the COMM pins can be used for resistive load modulation. Each COMM pin can handle at most a 24Ω communication resistor. Therefore, if a COMM resistor between 12Ω and 24Ω is required COM1 and COM2 pins must be connected in parallel. bq5101x does not support a COMM resistor less than 12Ω.

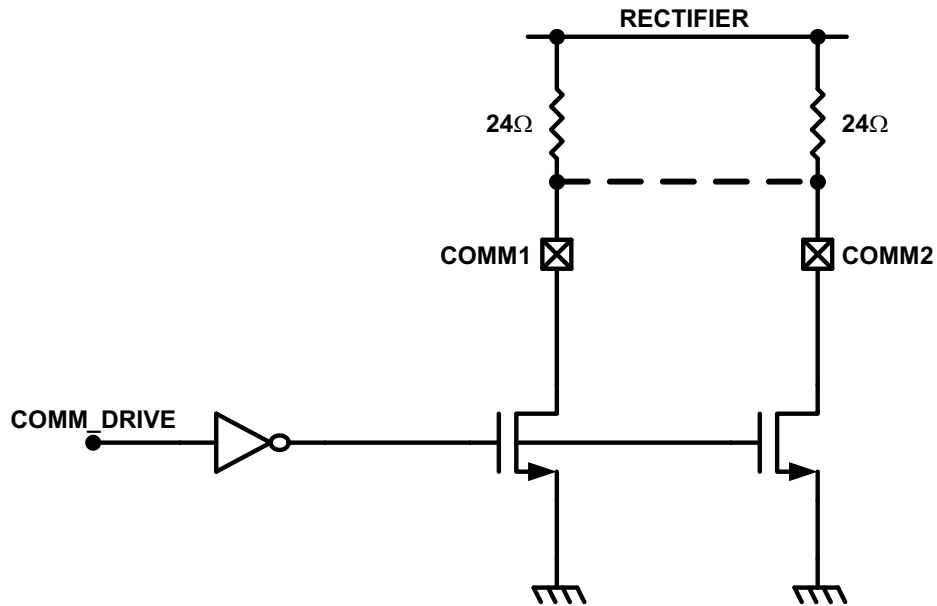

Figure 39. Resistive Load Modulation

In addition to resistive load modulation, the bq5101x is also capable of capacitive load modulation as shown in Figure 40 below. In this case, a capacitor is connected from COM1 to AC1 and from COM2 to AC2. When the COMM switches are closed there is effectively a 22 nF capacitor connected between AC1 and AC2. Connecting a capacitor in between AC1 and AC2 modulates the impedance seen by the coil, which will be reflected in the primary as a change in current.

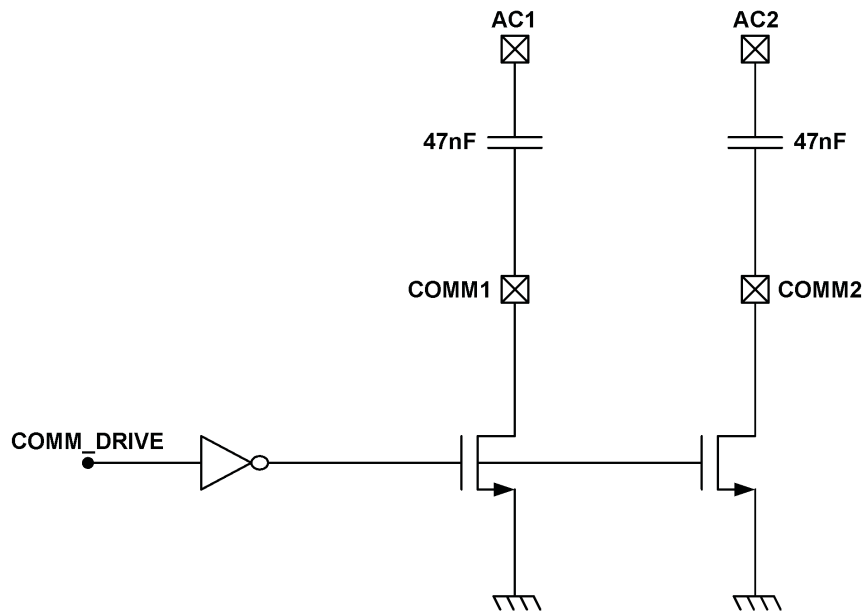

Figure 40. Capacitive Load Modulation

## Adaptive Communication Limit

The Qi communication channel is established via backscatter modulation as described in the previous sections. This type of modulation takes advantage of the loosely coupled inductor relationship between the Rx and Tx coil. Essentially the switching in-and-out of the communication capacitor or resistor adds a transient load to the Rx coil in order to modulate the Tx coil voltage/current waveform (amplitude modulation). The consequence of this technique is that a load transient (load current noise) from the mobile device has the same signature. In order to provide noise immunity to the communication channel, the output load transients must be isolated from the Rx coil. The proprietary feature *Adaptive Communication Limit* achieves this by dynamically adjusting the current limit of the regulator. When the regulator is put in current limit, any load transients will be offloaded to the battery in the system.

Note that this requires the battery charger IC to have input voltage regulation (weak adapter mode). The output of the Rx appears as a weak supply if a transient occurs above the current limit of the regulator.

The Adaptive Communication Limit feature has two current limit modes and is detailed in the table below:

**Table 5.**

$I_{OUT}$	Communication Current Limit
< 300 mA	Fixed 400 mA
> 300 mA	$I_{OUT} + 50$ mA

The first mode is illustrated in [Figure 25](#). In this plot, an output load pulse of 300 mA is periodically introduced on a DC current level of 200 mA. Therefore, the 400 mA current limit is enabled. The pulses on  $V_{RECT}$  indicate that a communication packet event is occurring. When the output load pulse occurs, the regulator limits the pulse to a constant 400 mA and; therefore, preserves communication. Note that  $V_{OUT}$  drops to 4.5 V instead of GND. A charger IC with an input voltage regulation set to 4.5 V allows this to occur by offloading the load transient support to the mobile device's battery

The second mode is illustrated in [Figure 26](#). In this plot, an output pulse of 200 mA is periodically introduced on a DC current level of 400 mA. Therefore, the tracking current mode ( $I_{OUT} + 50$  mA) is enabled. In this mode the bq5101x measures the active output current and sets the regulators current limit 50 mA above this measurement. When the load pulse occurs during a communication packet event, the output current is regulated to 450 mA. As the communication packet event has finished the output load is allowed to increase. Note that during the time the regulator is in current limit  $V_{OUT}$  is reduced to 4.5 V and 5 V when not in current limit.

## Synchronous Rectification

The bq5101x provides an integrated, self-driven synchronous rectifier that enables high-efficiency AC to DC power conversion. The rectifier consists of an all NMOS H-Bridge driver where the backgates of the diodes are configured to be the rectifier when the synchronous rectifier is disabled. During the initial startup of the WPC system the synchronous rectifier is not enabled. At this operating point, the DC rectifier voltage is provided by the diode rectifier. Once  $V_{RECT}$  is greater than UVLO, half synchronous mode will be enabled until the load current surpasses 120 mA. Above 120 mA the full synchronous rectifier stays enabled until the load current drops back below 100 mA where half synchronous mode is enabled instead.

## Temperature Sense Resistor Network (TS)

bq5101x includes a ratiometric external temperature sense function. The temperature sense function has two ratiometric thresholds which represent a hot and cold condition. An external temperature sensor is recommended in order to provide safe operating conditions for the receiver product. This pin is best used for monitoring the surface that can be exposed to the end user (e.g. place the NTC resistor closest to the user).

[Figure 41](#) allows for any NTC resistor to be used with the given  $V_{HOT}$  and  $V_{COLD}$  thresholds.

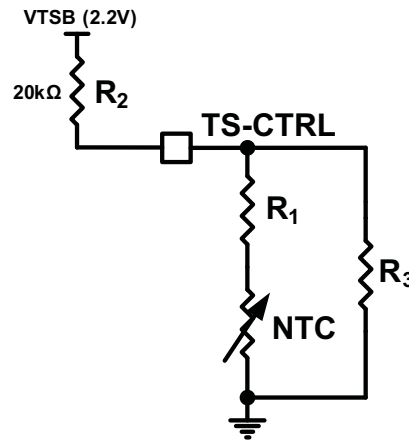

**Figure 41. NTC Circuit Used for Safe Operation of the Wireless Receiver Power Supply**

The resistors  $R_1$  and  $R_3$  can be solved by resolving the system of equations at the desired temperature thresholds. The two equations are:

$$\%V_{\text{COLD}} = \frac{\left( \frac{R_3 (R_{\text{NTC}}|_{T_{\text{COLD}}} + R_1)}{R_3 + (R_{\text{NTC}}|_{T_{\text{COLD}}} + R_1)} \right)}{\left( \frac{R_3 (R_{\text{NTC}}|_{T_{\text{COLD}}} + R_1)}{R_3 + (R_{\text{NTC}}|_{T_{\text{COLD}}} + R_1)} \right) + R_2} \times 100$$

$$\%V_{\text{HOT}} = \frac{\left( \frac{R_3 (R_{\text{NTC}}|_{T_{\text{HOT}}} + R_1)}{R_3 + (R_{\text{NTC}}|_{T_{\text{HOT}}} + R_1)} \right)}{\left( \frac{R_3 (R_{\text{NTC}}|_{T_{\text{HOT}}} + R_1)}{R_3 + (R_{\text{NTC}}|_{T_{\text{HOT}}} + R_1)} \right) + R_2} \times 100 \quad (4)$$

Where:

$$R_{\text{NTC}}|_{T_{\text{COLD}}} = R_0 e^{\beta \left( \frac{1}{T_{\text{COLD}}} - \frac{1}{T_0} \right)}$$

$$R_{\text{NTC}}|_{T_{\text{HOT}}} = R_0 e^{\beta \left( \frac{1}{T_{\text{HOT}}} - \frac{1}{T_0} \right)} \quad (5)$$

where,  $T_{\text{COLD}}$  and  $T_{\text{HOT}}$  are the desired temperature thresholds in degrees Kelvin.  $R_0$  is the nominal resistance and  $\beta$  is the temperature coefficient of the NTC resistor.  $R_0$  is fixed at 20 kΩ. An example solution is provided:

- $R_1 = 4.23\text{k}\Omega$
- $R_3 = 66.8\text{k}\Omega$

where the chosen parameters are:

- $\%V_{\text{HOT}} = 19.6\%$
- $\%V_{\text{COLD}} = 58.7\%$

**bq51013A**  
**bq51014**

SLUSAY6B – MARCH 2012 – REVISED OCTOBER 2013

www.ti.com

- $T_{COLD} = -10^{\circ}C$
- $T_{HOT} = 100^{\circ}C$
- $\beta = 3380$
- $R_O = 10k\Omega$

The plot of the percent  $V_{TSB}$  vs. temperature is shown in Figure 42:

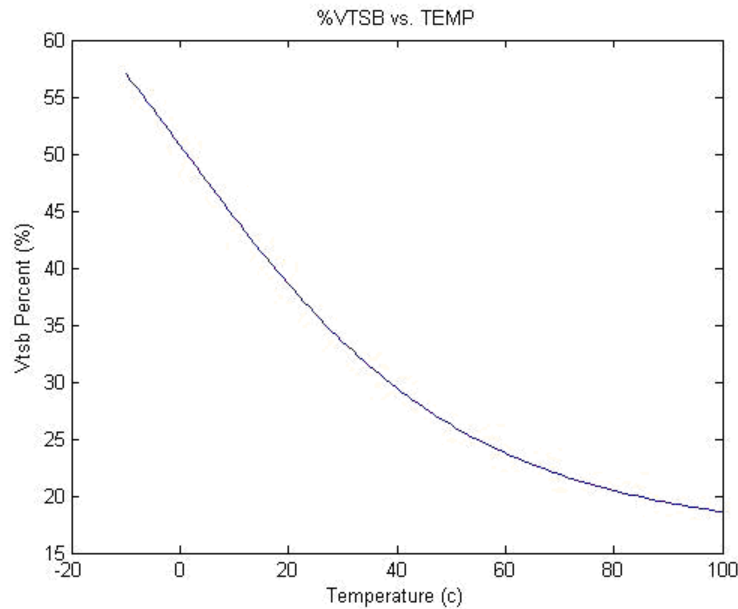

**Figure 42. Example Solution for an NTC resistor with  $R_O = 10K\Omega$  and  $\beta = 4500$**

Figure 43 illustrates the periodic biasing scheme used for measuring the TS state. The TS\_READ signal enables the TS bias voltage for 24ms. During this period the TS comparators are read (each comparator has a 10 ms deglitch) and appropriate action is taken based on the temperature measurement. After this 24ms period has elapsed, the TS\_READ signal goes low, which causes the TS-Bias pin to become high impedance. During the next 35ms (priority packet period) or 235ms (standard packet period), the TS voltage is monitored and compared to 100mV. If the TS voltage is greater than 100mV then a secondary device is driving the TS/CTRL pin and a CTRL = '1' is detected.

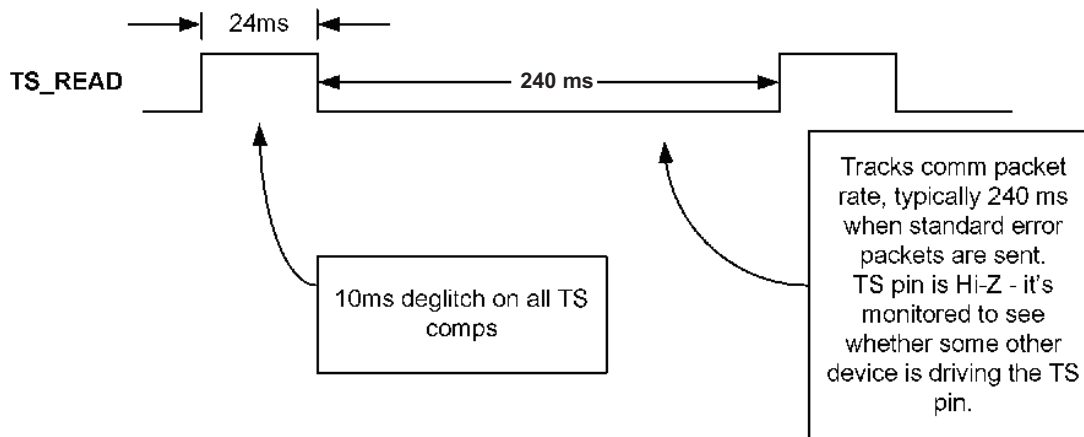

**Figure 43. Timing Diagram for TS Detection Circuit**

### 3-state Driver Recommendations for the TS-CTRL Pin

The TS-CTRL pin offers three functions with one 3-state driver interface

1. NTC temperature monitoring,
2. Fault indication,
3. Charge done indication

A 3-state driver can be implemented with the circuit in [Figure 44](#) and the use of two GPIO connections.

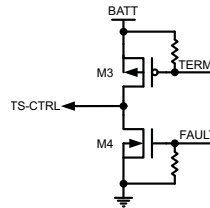

**Figure 44. 3-state Driver for TS-CTRL**

Note that the signals “TERM” and “FAULT” are given by two GPIO’s. The truth table for this circuit is found in [Table 6](#):

**Table 6.**

TERM	FAULT	F (Result)
1	0	Z (Normal Mode)
0	0	Charge Complete
1	1	System Fault

The default setting is TERM = 1 and FAULT = 0. In this condition, the TS-CTRL net is high impedance (hi-z) and; therefore, the NTC is function is allowed to operate. When the TS-CTRL pin is pulled to GND by setting FAULT = 1, the Rx is shutdown with the indication of a fault. When the TS-CTRL pin is pulled to the battery by setting TERM = 1, the Rx is shutdown with the indication of a charge complete condition. Therefore, the host controller can indicate whether the Rx is system is turning off due to a fault or due to a charge complete condition.

### Thermal Protection

The bq5101x includes a thermal shutdown protection. If the die temperature reaches  $T_J(\text{OFF})$ , the LDO is shut off to prevent any further power dissipation.

### Series and Parallel Resonant Capacitor Selection

Shown in [Figure 2](#), the capacitors C1 (series) and C2 (parallel) make up the dual resonant circuit with the receiver coil. These two capacitors must be sized correctly per the WPC v1.0 specification. [Figure 45](#) illustrates the equivalent circuit of the dual resonant circuit:

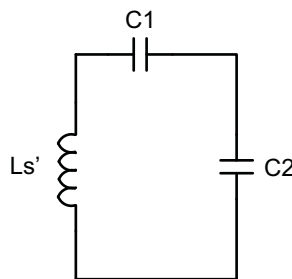

**Figure 45. Dual Resonant Circuit with the Receiver Coil**

Section 4.2 (Power Receiver Design Requirements) in volume 1 of the WPC v1.0 specification highlights in detail the sizing requirements. To summarize, the receiver designer will be required take inductance measurements with a fixed test fixture. The test fixture is shown in [Figure 46](#):

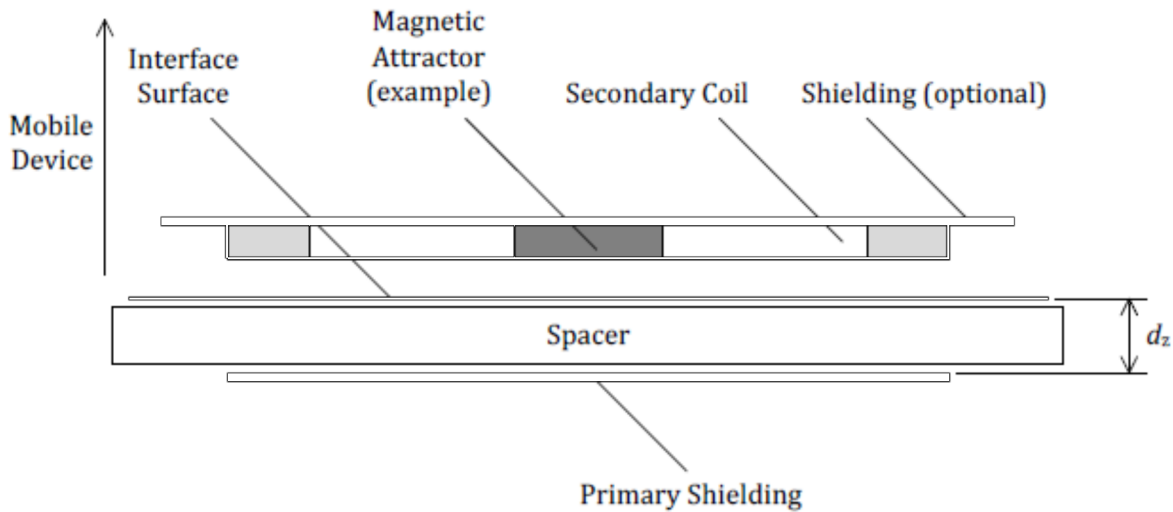

**Figure 46. WPC v1.0 Receiver Coil Test Fixture for the Inductance Measurement  $L_s'$  (copied from System Description Wireless Power Transfer, volume 1: Low Power, Part 1 Interface Definition, Version 1.0.1, Figure 4-4)**

The primary shield is to be 50 mm x 50 mm x 1 mm of Ferrite material PC44 from TDK Corp. The gap  $d_z$  is to be 3.4 mm. The receiver coil, as it will be placed in the final system (e.g. the back cover and battery must be included if the system calls for this), is to be placed on top of this surface and the inductance is to be measured at 1-V RMS and a frequency of 100 kHz. This measurement is termed  $L_s'$ . The same measurement is to be repeated without the test fixture shown in Figure 11. This measurement is termed  $L_s$  or the free-space inductance. Each capacitor can then be calculated using Equation 6:

$$C_1 = \left[ (f_S \cdot 2\pi)^2 \cdot L'_S \right]^{-1}$$

$$C_2 = \left[ (f_D \cdot 2\pi)^2 \cdot L_S - \frac{1}{C_1} \right]^{-1}$$
(6)

Where  $f_S$  is 100 kHz +5/-10% and  $f_D$  is 1 MHz ±10%.  $C_1$  must be chosen first prior to calculating  $C_2$ .

The quality factor must be greater than 77 and can be determined by Equation 7:

$$Q = \frac{2\pi \cdot f_D \cdot L_S}{R}$$
(7)

where  $R$  is the DC resistance of the receiver coil. All other constants are defined above.

### Receiver Coil Load-Line Analysis

When choosing a receiver coil, it is recommend to analyze the transformer characteristics between the primary coil and receiver coil via load-line analysis. This will capture two important conditions in the WPC system:

1. Operating point characteristics in the closed loop of the WPC system.
2. Instantaneous transient response prior to the convergence of the new operating point.

An example test configuration for conducting this analysis is shown in Figure 47:

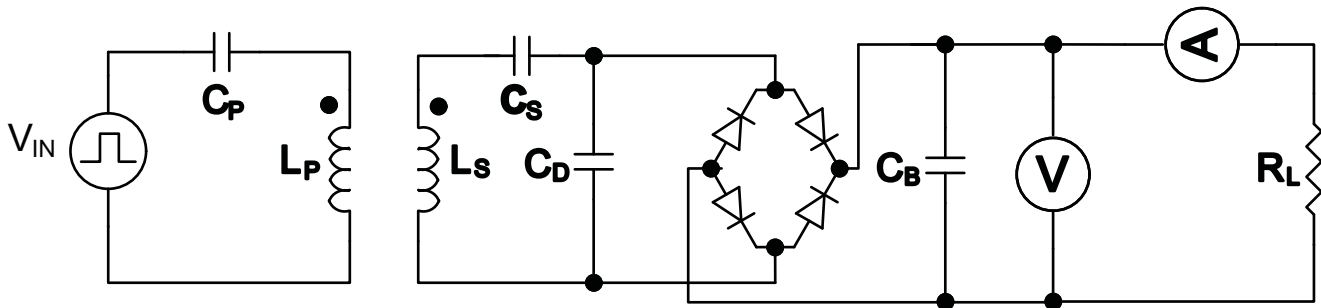

Figure 47. Load-Line Analysis Test Bench

Where:

- $V_{IN}$  is a square-wave power source that should have a peak-to-peak operation of 19V.
- $C_P$  is the primary series resonant capacitor (i.e. 100 nF for Type A1 coil).
- $L_P$  is the primary coil of interest (i.e. Type A1).
- $L_S$  is the secondary coil of interest.
- $C_S$  is the series resonant capacitor chosen for the receiver coil under test.
- $C_D$  is the parallel resonant capacitor chosen for the receiver coil under test.
- $C_B$  is the bulk capacitor of the diode bridge (voltage rating should be at least 25 V and capacitance value of at least 10 $\mu$  F)
- V is a Kelvin connected voltage meter
- A is a series ammeter
- $R_L$  is the load of interest

It is recommended that the diode bridge be constructed of Schottky diodes.

The test procedure is as follows

- Supply a 19V AC signal to  $L_P$  starting at a frequency of 210 kHz
- Measure the resulting rectified voltage from no load to the expected full load
- Repeat the above steps for lower frequencies (stopping at 110 kHz)

An example load-line analysis is shown in [Figure 48](#):

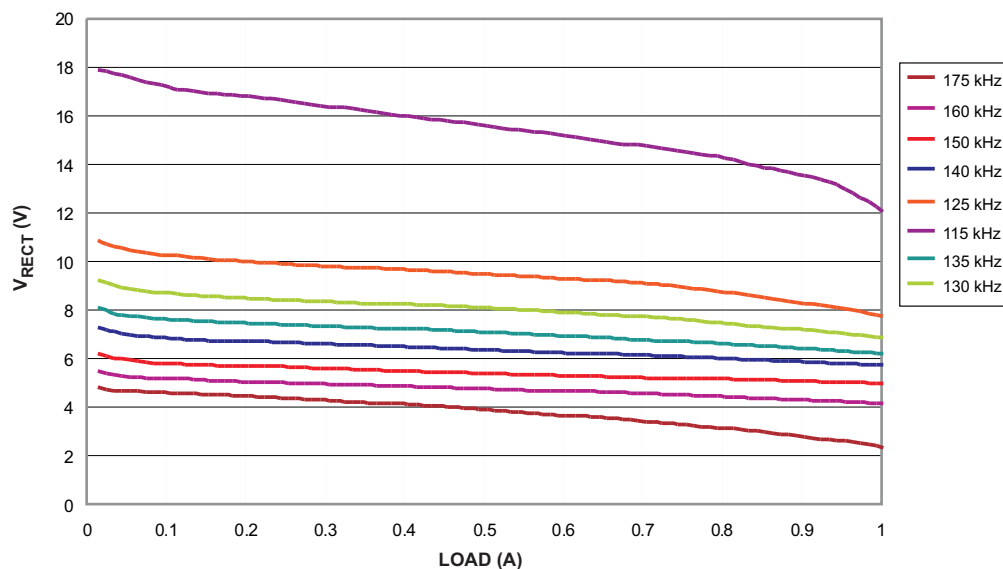

Figure 48. Example Load-Line Results

**bq51013A**  
**bq51014**

SLUSAY6B – MARCH 2012 – REVISED OCTOBER 2013

[www.ti.com](http://www.ti.com)

What this plot conveys about the operating point is that a specific load and rectifier target condition consequently results in a specific operating frequency (for the type A1 TX). For example, at 1 A the dynamic rectifier target is 5.15 V. Therefore, the operating frequency will be between 150kHz and 160kHz in the above example. This is an acceptable operating point. If the operating point ever falls outside the WPC frequency range (110kHz – 205kHz), the system will never converge and will become unstable.

In regards to transient analysis, there are two major points of interest:

1. Rectifier voltage at the ping frequency (175kHz).
2. Rectifier voltage droop from no load to full load at the constant operating point.

In this example, the ping voltage will be approximately 5 V. This is above the UVLO of the bq5101x and; therefore, startup in the WPC system can be ensured. If the voltage is near or below the UVLO at this frequency, then startup in the WPC system may not occur.

If the max load step is 1 A, the droop in this example will be Approximately 1V with a voltage at 1 A of Approximately 5.5 V (140 kHz load-line). To analyze the droop locate the load-line that starts at 7 V at no-load. Follow this load-line to the max load expected and take the difference between the 7V no-load voltage and the full-load voltage at that constant frequency. Ensure that the full-load voltage at this constant frequency is above 5V. If it descends below 5V, the output of the power supply will also droop to this level. This type of transient response analysis is necessary due to the slow feedback response of the WPC system. This simulates the step response prior to the WPC system adjusting the operating point.

---

**NOTE**

Coupling between the primary and secondary coils will worsen with misalignment of the secondary coil. Therefore, it is recommended to re-analyze the load-lines at multiple misalignments to determine where, in planar space, the receiver will discontinue operation.

---

Recommended Rx coils can be found in [Table 7](#):

**Table 7.**

Manufacturer	Part Number	Dimensions	Ls	Ls'	Output Current Range	Application
TDK	WR-483250-15M2-G	48 x 32mm	10.4 $\mu$ H	12 $\mu$ H <sup>(1)</sup>	50-1000 mA	General 5V Power Supply
TDK	WR-383250-17M2-G	38 x 32mm	11.1 $\mu$ H	12.3 $\mu$ H <sup>(1)</sup>	50-1000 mA	Space limited 5V Power Supply
Vishay	IWAS-4832FF-50	48 x 32mm	10.8 $\mu$ H	12.5 $\mu$ H <sup>(1)</sup>	50-1000 mA	General 5V Power Supply
Mingstar	312-00012	48 x 32mm	10.8 $\mu$ H	12.9 $\mu$ H <sup>(1)</sup>	50-1000 mA	General 5V power Supply
Mingstar	312-00015	28 x 14mm	36.5 $\mu$ H	45 $\mu$ H <sup>(2)</sup>	150-1000 mA	Space limited 5V Power Supply

- (1) Ls' measurements conducted with a standard battery behind the Rx coil assembly. This measurement is subject to change based on different battery sizes, placements, and casing material.
- (2) Battery not present behind the Rx coil assembly. Subject to drop in inductance depending on the placement of the battery.

It is recommended that all inductance measurements are repeated in the designers specific system as there are many influence on the final measurements.

**Package Summary**

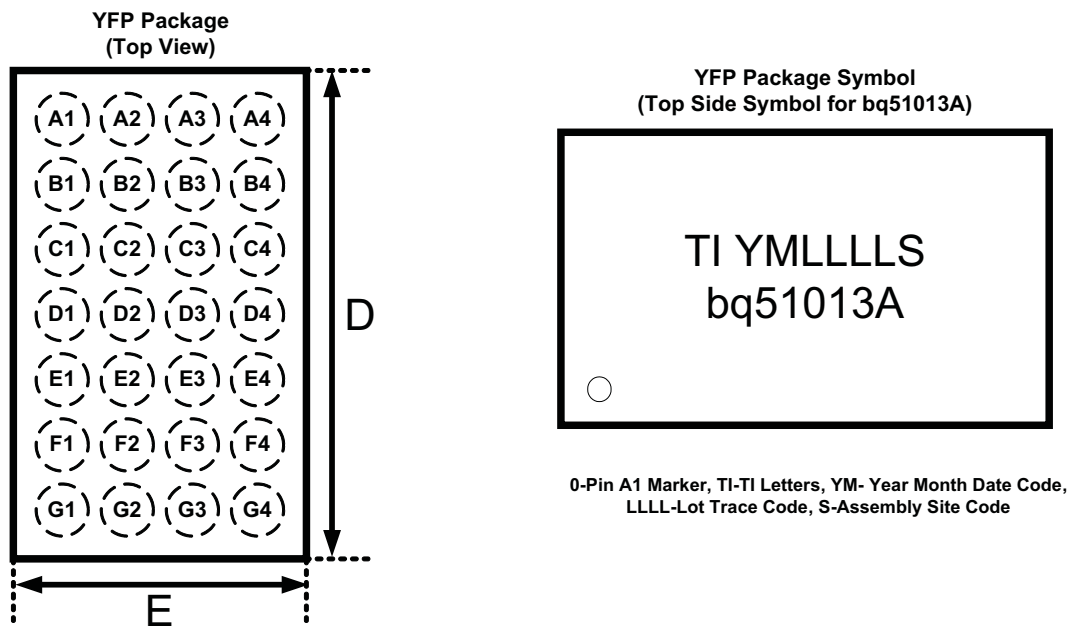

**Figure 49. Chip Scale Packaging Dimensions**

- D = 3.0mm  $\pm$  0.035mm
- E = 1.88mm  $\pm$  0.035mm

## REVISION HISTORY

---

**Changes from Original (March 2012) to Revision A** **Page**

- Deleted  $V_{RECT-TRACK}$  from the Electrical Characteristics table ..... **6**
- 

**Changes from Revision A (June 2012) to Revision B** **Page**

- Changed AC1, AC2 input voltage spec MINIMUM value from –0.3 to –0.8 in the Absolute Maximum Ratings table ..... **2**
  - Changed condition statement of Electrical Characteristics section from "0°C to 125°C" to "–40°C to 125°C" ..... **6**
  - Changed UVLO spec MIN value from "2.6" to "2.5" ..... **6**
  - Changed  $V_{OUT-REG}$  spec MIN value from "4.85" to "4.82" for  $I_{LOAD} = 1000$  mA condition. .... **6**
  - Changed  $V_{OUT-REG}$  spec MIN value from "4.95" to "4.92" for  $I_{LOAD} = 10$  mA condition. .... **6**
-

**PACKAGING INFORMATION**

Orderable Device	Status (1)	Package Type	Package Drawing	Pins	Package Qty	Eco Plan (2)	Lead/Ball Finish (6)	MSL Peak Temp (3)	Op Temp (°C)	Device Marking (4/5)	Samples
BQ51013ARHLR	ACTIVE	VQFN	RHL	20	3000	Green (RoHS & no Sb/Br)	CU NIPDAU	Level-2-260C-1 YEAR	0 to 125	BQ51013A	<a href="#">Samples</a>
BQ51013ARHLT	ACTIVE	VQFN	RHL	20	250	Green (RoHS & no Sb/Br)	CU NIPDAU	Level-2-260C-1 YEAR	0 to 125	BQ51013A	<a href="#">Samples</a>
BQ51013AYFPR	ACTIVE	DSBGA	YFP	28	3000	Green (RoHS & no Sb/Br)	SNAGCU	Level-1-260C-UNLIM	0 to 125	BQ51013A	<a href="#">Samples</a>
BQ51013AYFPT	ACTIVE	DSBGA	YFP	28	250	Green (RoHS & no Sb/Br)	SNAGCU	Level-1-260C-UNLIM	0 to 125	BQ51013A	<a href="#">Samples</a>
BQ51014YFPR	NRND	DSBGA	YFP	28	3000	Green (RoHS & no Sb/Br)	SNAGCU	Level-1-260C-UNLIM	0 to 125	BQ51014	
BQ51014YFPT	NRND	DSBGA	YFP	28	250	Green (RoHS & no Sb/Br)	SNAGCU	Level-1-260C-UNLIM	0 to 125	BQ51014	
HPA01195YFPR	ACTIVE	DSBGA	YFP	28	3000	Green (RoHS & no Sb/Br)	SNAGCU	Level-1-260C-UNLIM	0 to 125	BQ51013A	<a href="#">Samples</a>

(1) The marketing status values are defined as follows:

**ACTIVE:** Product device recommended for new designs.

**LIFEBUY:** TI has announced that the device will be discontinued, and a lifetime-buy period is in effect.

**NRND:** Not recommended for new designs. Device is in production to support existing customers, but TI does not recommend using this part in a new design.

**PREVIEW:** Device has been announced but is not in production. Samples may or may not be available.

**OBSELETE:** TI has discontinued the production of the device.

(2) Eco Plan - The planned eco-friendly classification: Pb-Free (RoHS), Pb-Free (RoHS Exempt), or Green (RoHS & no Sb/Br) - please check <http://www.ti.com/productcontent> for the latest availability information and additional product content details.

**TBD:** The Pb-Free/Green conversion plan has not been defined.

**Pb-Free (RoHS):** TI's terms "Lead-Free" or "Pb-Free" mean semiconductor products that are compatible with the current RoHS requirements for all 6 substances, including the requirement that lead not exceed 0.1% by weight in homogeneous materials. Where designed to be soldered at high temperatures, TI Pb-Free products are suitable for use in specified lead-free processes.

**Pb-Free (RoHS Exempt):** This component has a RoHS exemption for either 1) lead-based flip-chip solder bumps used between the die and package, or 2) lead-based die adhesive used between the die and leadframe. The component is otherwise considered Pb-Free (RoHS compatible) as defined above.

**Green (RoHS & no Sb/Br):** TI defines "Green" to mean Pb-Free (RoHS compatible), and free of Bromine (Br) and Antimony (Sb) based flame retardants (Br or Sb do not exceed 0.1% by weight in homogeneous material)

(3) MSL, Peak Temp. - The Moisture Sensitivity Level rating according to the JEDEC industry standard classifications, and peak solder temperature.

(4) There may be additional marking, which relates to the logo, the lot trace code information, or the environmental category on the device.

<sup>(5)</sup> Multiple Device Markings will be inside parentheses. Only one Device Marking contained in parentheses and separated by a "-" will appear on a device. If a line is indented then it is a continuation of the previous line and the two combined represent the entire Device Marking for that device.

<sup>(6)</sup> Lead/Ball Finish - Orderable Devices may have multiple material finish options. Finish options are separated by a vertical ruled line. Lead/Ball Finish values may wrap to two lines if the finish value exceeds the maximum column width.

**Important Information and Disclaimer:**The information provided on this page represents TI's knowledge and belief as of the date that it is provided. TI bases its knowledge and belief on information provided by third parties, and makes no representation or warranty as to the accuracy of such information. Efforts are underway to better integrate information from third parties. TI has taken and continues to take reasonable steps to provide representative and accurate information but may not have conducted destructive testing or chemical analysis on incoming materials and chemicals. TI and TI suppliers consider certain information to be proprietary, and thus CAS numbers and other limited information may not be available for release.

In no event shall TI's liability arising out of such information exceed the total purchase price of the TI part(s) at issue in this document sold by TI to Customer on an annual basis.

**TAPE AND REEL INFORMATION**

**QUADRANT ASSIGNMENTS FOR PIN 1 ORIENTATION IN TAPE**

\*All dimensions are nominal

Device	Package Type	Package Drawing	Pins	SPQ	Reel Diameter (mm)	Reel Width W1 (mm)	A0 (mm)	B0 (mm)	K0 (mm)	P1 (mm)	W (mm)	Pin1 Quadrant
BQ51013ARHLR	VQFN	RHL	20	3000	330.0	12.4	3.71	4.71	1.1	8.0	12.0	Q1
BQ51013ARHLT	VQFN	RHL	20	250	180.0	12.4	3.71	4.71	1.1	8.0	12.0	Q1
BQ51013AYFPR	DSBGA	YFP	28	3000	180.0	8.4	2.0	3.13	0.6	4.0	8.0	Q1
BQ51013AYFPT	DSBGA	YFP	28	250	180.0	8.4	2.0	3.13	0.6	4.0	8.0	Q1
BQ51014YFPR	DSBGA	YFP	28	3000	180.0	8.4	2.0	3.13	0.6	4.0	8.0	Q1
BQ51014YFPT	DSBGA	YFP	28	250	180.0	8.4	2.0	3.13	0.6	4.0	8.0	Q1

**TAPE AND REEL BOX DIMENSIONS**

\*All dimensions are nominal

Device	Package Type	Package Drawing	Pins	SPQ	Length (mm)	Width (mm)	Height (mm)
BQ51013ARHLR	VQFN	RHL	20	3000	367.0	367.0	35.0
BQ51013ARHLT	VQFN	RHL	20	250	210.0	185.0	35.0
BQ51013AYFPR	DSBGA	YFP	28	3000	182.0	182.0	20.0
BQ51013AYFPT	DSBGA	YFP	28	250	182.0	182.0	20.0
BQ51014YFPR	DSBGA	YFP	28	3000	182.0	182.0	20.0
BQ51014YFPT	DSBGA	YFP	28	250	182.0	182.0	20.0

**GENERIC PACKAGE VIEW**

**RHL 20**

**VQFN - 1 mm max height**

**3.5 x 4.5 mm, 0.5 mm pitch**

PLASTIC QUAD FLATPACK - NO LEAD

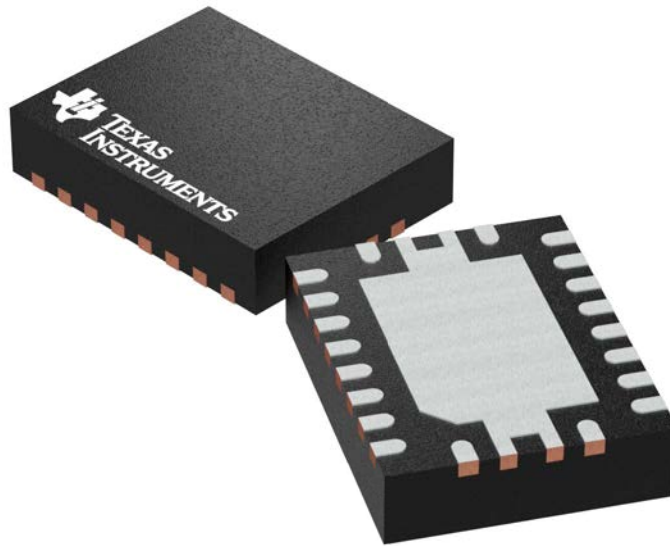

Images above are just a representation of the package family, actual package may vary.  
Refer to the product data sheet for package details.

4205346/L

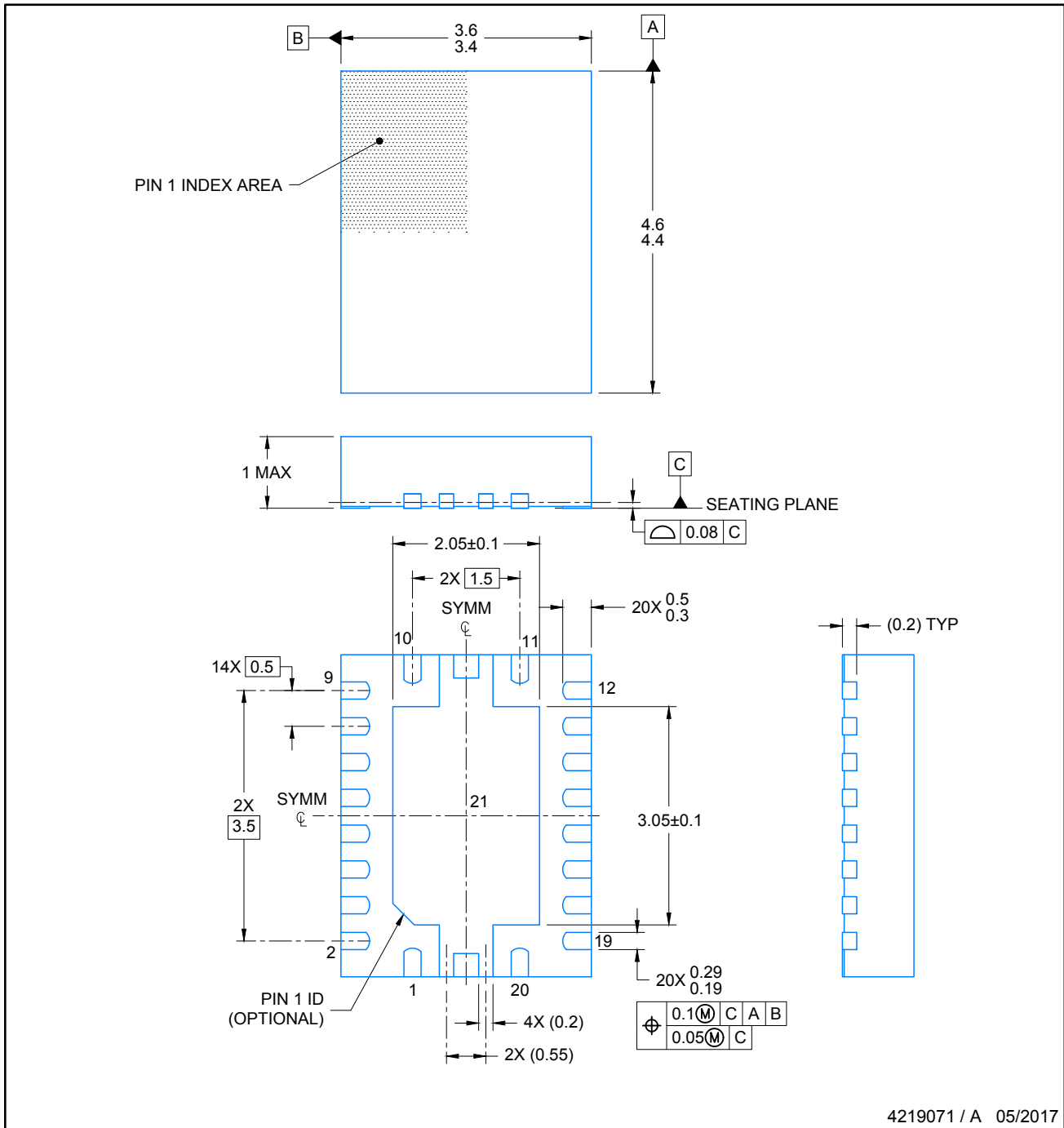

NOTES:

1. All linear dimensions are in millimeters. Any dimensions in parenthesis are for reference only. Dimensioning and tolerancing per ASME Y14.5M.
2. This drawing is subject to change without notice.
3. The package thermal pad must be soldered to the printed circuit board for thermal and mechanical performance.

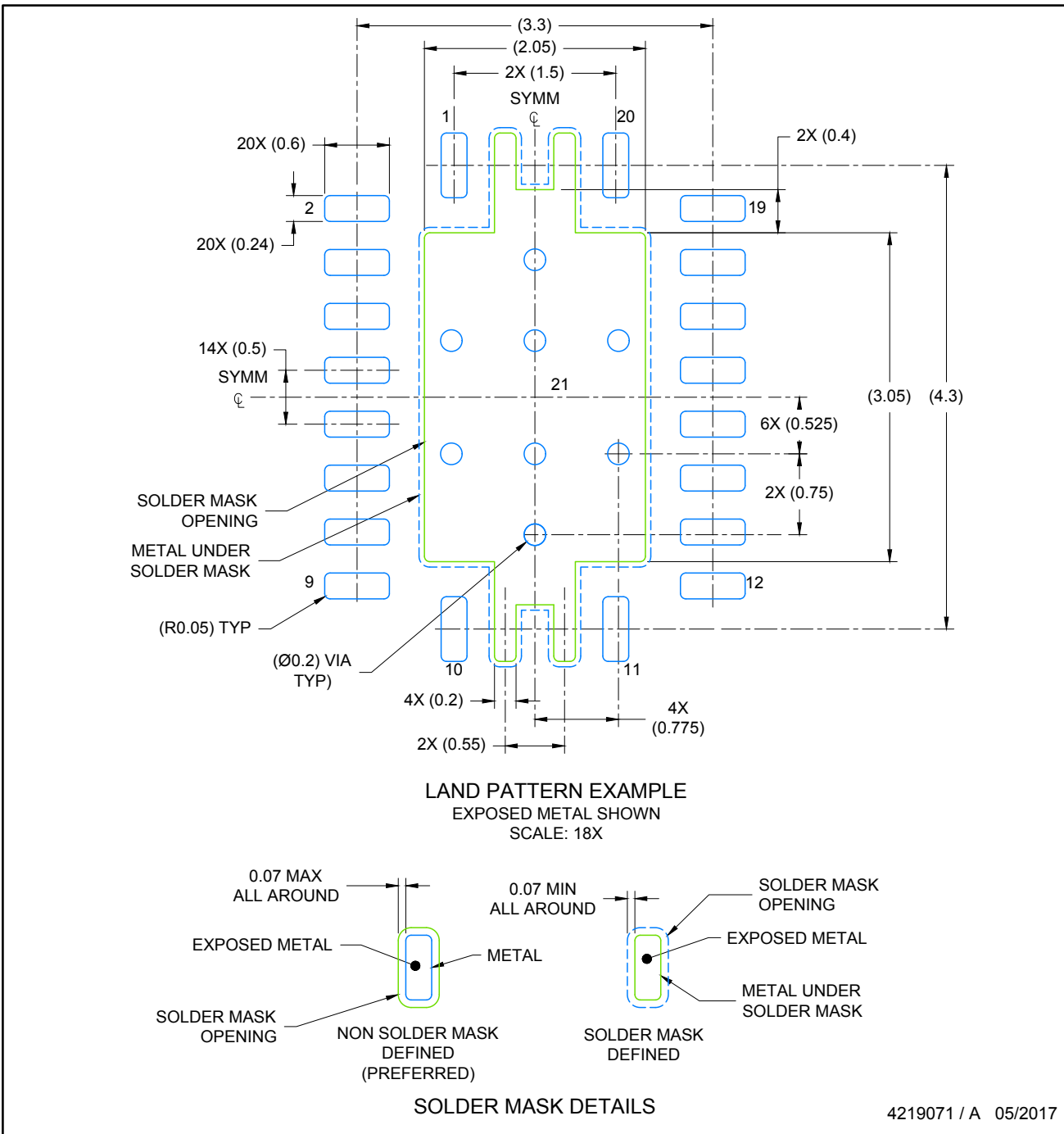

NOTES: (continued)

4. This package is designed to be soldered to a thermal pad on the board. For more information, see Texas Instruments literature number SLUA271 ([www.ti.com/lit/slua271](http://www.ti.com/lit/slua271)).
5. Solder mask tolerances between and around signal pads can vary based on board fabrication site.
6. Vias are optional depending on application, refer to device data sheet. If any vias are implemented, refer to their locations shown on this view. It is recommended that vias under paste be filled, plugged or tented.

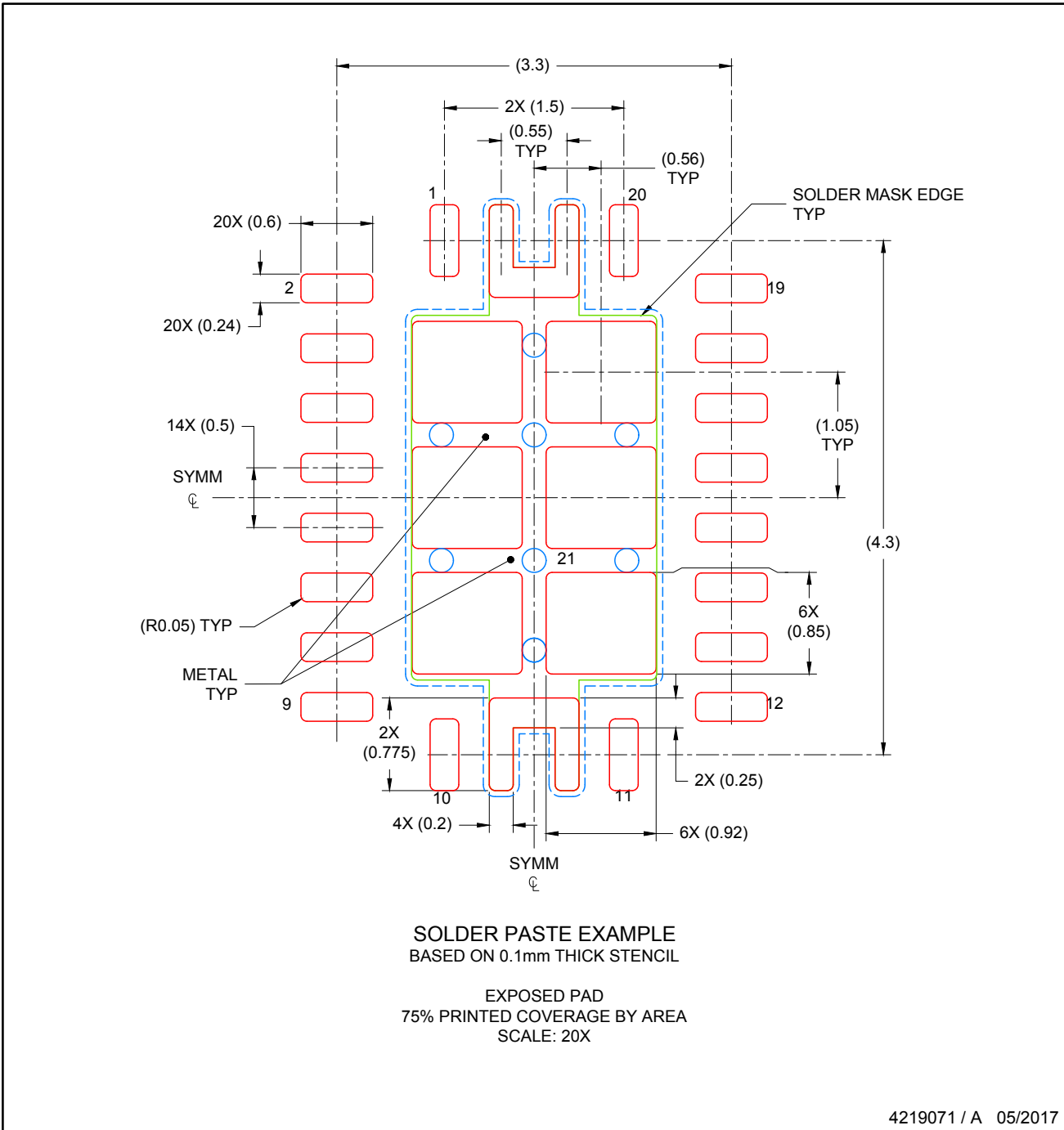

NOTES: (continued)

7. Laser cutting apertures with trapezoidal walls and rounded corners may offer better paste release. IPC-7525 may have alternate design recommendations..

YFP (R-XBGA-N28)

DIE-SIZE BALL GRID ARRAY

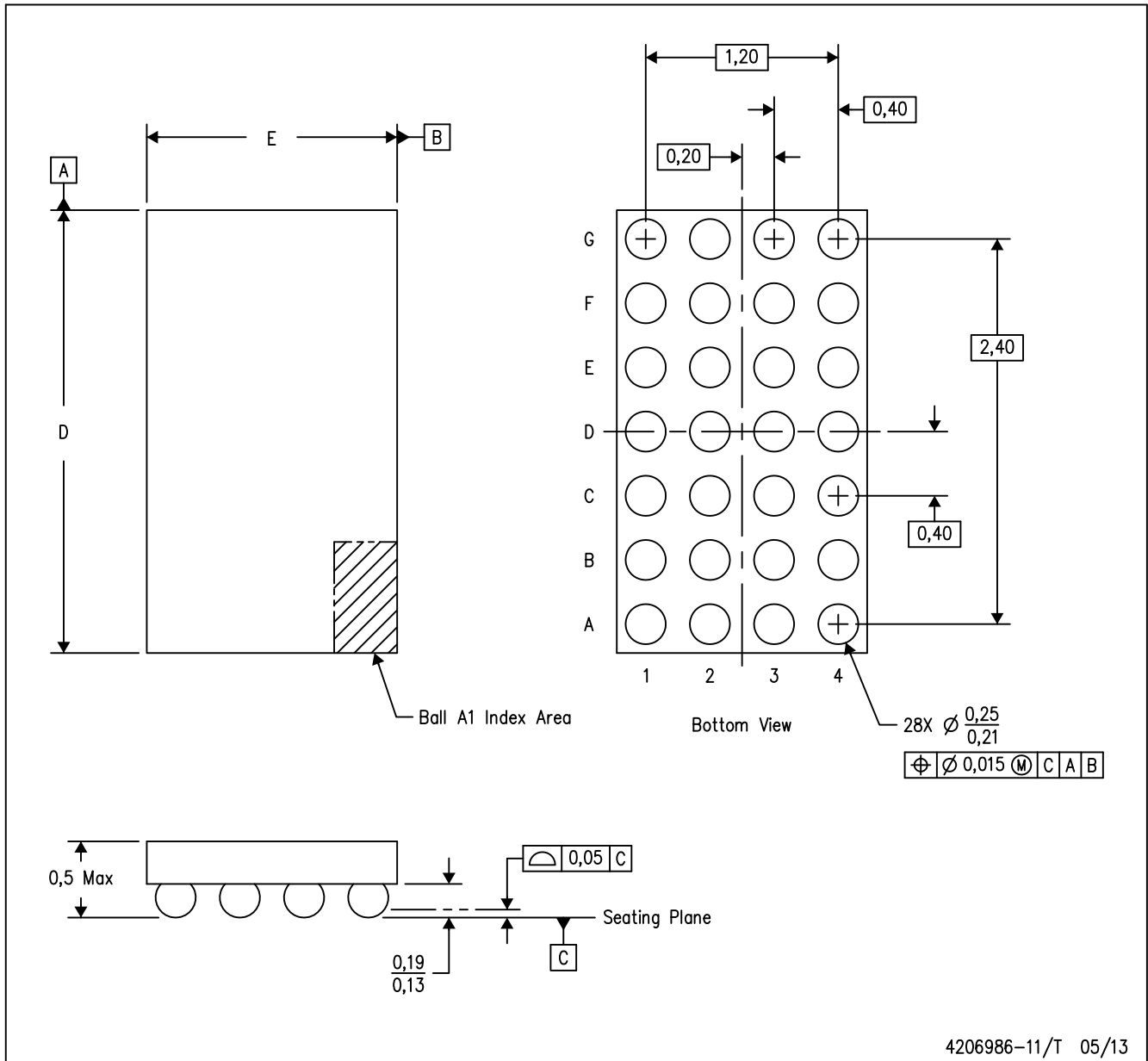

- NOTES:
- A. All linear dimensions are in millimeters. Dimensioning and tolerancing per ASME Y14.5M-1994.
  - B. This drawing is subject to change without notice.
  - C. NanoFree™ package configuration.

## IMPORTANT NOTICE

Texas Instruments Incorporated (TI) reserves the right to make corrections, enhancements, improvements and other changes to its semiconductor products and services per JESD46, latest issue, and to discontinue any product or service per JESD48, latest issue. Buyers should obtain the latest relevant information before placing orders and should verify that such information is current and complete.

TI's published terms of sale for semiconductor products (<http://www.ti.com/sc/docs/stdterms.htm>) apply to the sale of packaged integrated circuit products that TI has qualified and released to market. Additional terms may apply to the use or sale of other types of TI products and services.

Reproduction of significant portions of TI information in TI data sheets is permissible only if reproduction is without alteration and is accompanied by all associated warranties, conditions, limitations, and notices. TI is not responsible or liable for such reproduced documentation. Information of third parties may be subject to additional restrictions. Resale of TI products or services with statements different from or beyond the parameters stated by TI for that product or service voids all express and any implied warranties for the associated TI product or service and is an unfair and deceptive business practice. TI is not responsible or liable for any such statements.

Buyers and others who are developing systems that incorporate TI products (collectively, "Designers") understand and agree that Designers remain responsible for using their independent analysis, evaluation and judgment in designing their applications and that Designers have full and exclusive responsibility to assure the safety of Designers' applications and compliance of their applications (and of all TI products used in or for Designers' applications) with all applicable regulations, laws and other applicable requirements. Designer represents that, with respect to their applications, Designer has all the necessary expertise to create and implement safeguards that (1) anticipate dangerous consequences of failures, (2) monitor failures and their consequences, and (3) lessen the likelihood of failures that might cause harm and take appropriate actions. Designer agrees that prior to using or distributing any applications that include TI products, Designer will thoroughly test such applications and the functionality of such TI products as used in such applications.

TI's provision of technical, application or other design advice, quality characterization, reliability data or other services or information, including, but not limited to, reference designs and materials relating to evaluation modules, (collectively, "TI Resources") are intended to assist designers who are developing applications that incorporate TI products; by downloading, accessing or using TI Resources in any way, Designer (individually or, if Designer is acting on behalf of a company, Designer's company) agrees to use any particular TI Resource solely for this purpose and subject to the terms of this Notice.

TI's provision of TI Resources does not expand or otherwise alter TI's applicable published warranties or warranty disclaimers for TI products, and no additional obligations or liabilities arise from TI providing such TI Resources. TI reserves the right to make corrections, enhancements, improvements and other changes to its TI Resources. TI has not conducted any testing other than that specifically described in the published documentation for a particular TI Resource.

Designer is authorized to use, copy and modify any individual TI Resource only in connection with the development of applications that include the TI product(s) identified in such TI Resource. NO OTHER LICENSE, EXPRESS OR IMPLIED, BY ESTOPPEL OR OTHERWISE TO ANY OTHER TI INTELLECTUAL PROPERTY RIGHT, AND NO LICENSE TO ANY TECHNOLOGY OR INTELLECTUAL PROPERTY RIGHT OF TI OR ANY THIRD PARTY IS GRANTED HEREIN, including but not limited to any patent right, copyright, mask work right, or other intellectual property right relating to any combination, machine, or process in which TI products or services are used. Information regarding or referencing third-party products or services does not constitute a license to use such products or services, or a warranty or endorsement thereof. Use of TI Resources may require a license from a third party under the patents or other intellectual property of the third party, or a license from TI under the patents or other intellectual property of TI.

TI RESOURCES ARE PROVIDED "AS IS" AND WITH ALL FAULTS. TI DISCLAIMS ALL OTHER WARRANTIES OR REPRESENTATIONS, EXPRESS OR IMPLIED, REGARDING RESOURCES OR USE THEREOF, INCLUDING BUT NOT LIMITED TO ACCURACY OR COMPLETENESS, TITLE, ANY EPIDEMIC FAILURE WARRANTY AND ANY IMPLIED WARRANTIES OF MERCHANTABILITY, FITNESS FOR A PARTICULAR PURPOSE, AND NON-INFRINGEMENT OF ANY THIRD PARTY INTELLECTUAL PROPERTY RIGHTS. TI SHALL NOT BE LIABLE FOR AND SHALL NOT DEFEND OR INDEMNIFY DESIGNER AGAINST ANY CLAIM, INCLUDING BUT NOT LIMITED TO ANY INFRINGEMENT CLAIM THAT RELATES TO OR IS BASED ON ANY COMBINATION OF PRODUCTS EVEN IF DESCRIBED IN TI RESOURCES OR OTHERWISE. IN NO EVENT SHALL TI BE LIABLE FOR ANY ACTUAL, DIRECT, SPECIAL, COLLATERAL, INDIRECT, PUNITIVE, INCIDENTAL, CONSEQUENTIAL OR EXEMPLARY DAMAGES IN CONNECTION WITH OR ARISING OUT OF TI RESOURCES OR USE THEREOF, AND REGARDLESS OF WHETHER TI HAS BEEN ADVISED OF THE POSSIBILITY OF SUCH DAMAGES.

Unless TI has explicitly designated an individual product as meeting the requirements of a particular industry standard (e.g., ISO/TS 16949 and ISO 26262), TI is not responsible for any failure to meet such industry standard requirements.

Where TI specifically promotes products as facilitating functional safety or as compliant with industry functional safety standards, such products are intended to help enable customers to design and create their own applications that meet applicable functional safety standards and requirements. Using products in an application does not by itself establish any safety features in the application. Designers must ensure compliance with safety-related requirements and standards applicable to their applications. Designer may not use any TI products in life-critical medical equipment unless authorized officers of the parties have executed a special contract specifically governing such use. Life-critical medical equipment is medical equipment where failure of such equipment would cause serious bodily injury or death (e.g., life support, pacemakers, defibrillators, heart pumps, neurostimulators, and implantables). Such equipment includes, without limitation, all medical devices identified by the U.S. Food and Drug Administration as Class III devices and equivalent classifications outside the U.S.

TI may expressly designate certain products as completing a particular qualification (e.g., Q100, Military Grade, or Enhanced Product). Designers agree that it has the necessary expertise to select the product with the appropriate qualification designation for their applications and that proper product selection is at Designers' own risk. Designers are solely responsible for compliance with all legal and regulatory requirements in connection with such selection.

Designer will fully indemnify TI and its representatives against any damages, costs, losses, and/or liabilities arising out of Designer's non-compliance with the terms and provisions of this Notice.

## Looking for pricing, stock, or lifecycle information?

Click below to explore more details on WIN SOURCE:

 [View BQ51013AYFPT on WIN SOURCE](#)

 [Texas Instruments](#) Information

## Optimize Your Supply Chain with WIN SOURCE Solutions

-  Global Sourcing Solution
-  Obsolete Management
-  Cost Control Management
-  Shortage Management
-  Alternative Solution
-  Excess Inventory Management