



**THE DATASHEET OF
BQ51025YFPT**



bq51025 WPC v1.2 Compliant Single Chip Wireless Power Receiver With Proprietary 10-W Power Delivery

1 Features

- Robust 10-W Receiver Solution Using Proprietary Protocol With TI's 10-W bq500215 Transmitter
 - Post-Regulation LDO to Protect External Charger Input from Rectifier Output Transients; Inductorless Solution for Lowest Height
 - Adjustable Output Voltage (4.5 to 10 V) for Coil and Thermal Optimization
 - Supports 2S Battery Configuration (Non-WPC compliant)
 - Fully Synchronous Rectifier With 96% Efficiency
 - 97% Efficient Post Regulator
 - 84% System Efficiency at 10 W
- WPC v1.2 Compliant Communication and Control for Compatibility With Current TX Solutions
- Patented Transmitter Pad Detect Function Improves User Experience
- Power Signal Frequency Measurement Allows Host to Determine Optimal Placement on TX Surface
- I²C Communication With Host

2 Applications

- Smart Phones, Tablets, and Headsets
- Point-of-Sale Devices
- 2S Battery Applications
- Power Banks
- Other Portable Devices

3 Description

The bq51025 device is a fully-contained wireless power receiver capable of operating in the Wireless Power Consortium (WPC) Qi protocol, which allows a wireless power system to deliver 5 W to the system with Qi inductive transmitters and up to 10 W when operating with the bq500215 primary-side controller. The bq51025 device provides a single device power conversion (rectification and regulation) as well as the digital control and communication as per WPC v1.2 specification. With market-leading 84% system efficiency and adjustable output voltage, the bq51025 device allows for unparalleled system optimization. With a maximum output voltage of 10 V, the bq51025 offers a flexible solution that offers a wireless power solution for 2S battery application and allows optimal thermal performance of the system. The I²C interface allows system designers to implement new features such as aligning a receiver on the transmitter surface or detecting foreign objects on the receiver. The bq51025 device complies with the WPC v1.2 communication protocol making it compatible with all WPC transmitter solutions. The receiver allows for synchronous rectification, regulation and control, and communication to all exist in a market-leading form factor, efficiency, and solution size.

Device Information⁽¹⁾

PART NUMBER	PACKAGE	BODY SIZE (NOM)
bq51025	DSBGA (42)	3.60 mm x 2.89 mm

(1) For all available packages, see the orderable addendum at the end of the data sheet.

Simplified Schematic

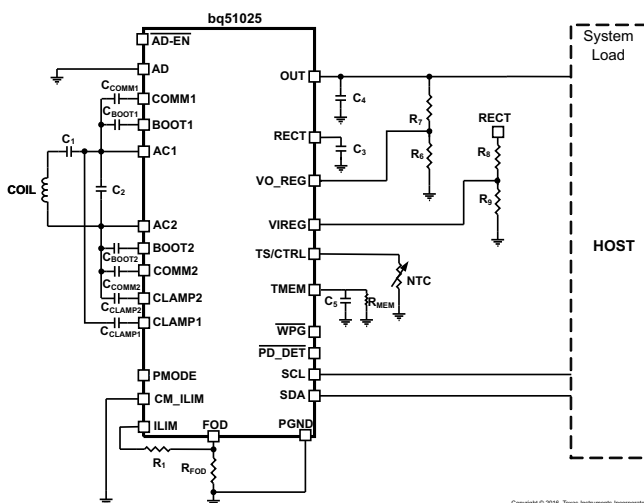

bq51025 System Efficiency With bq500215 TX Controller

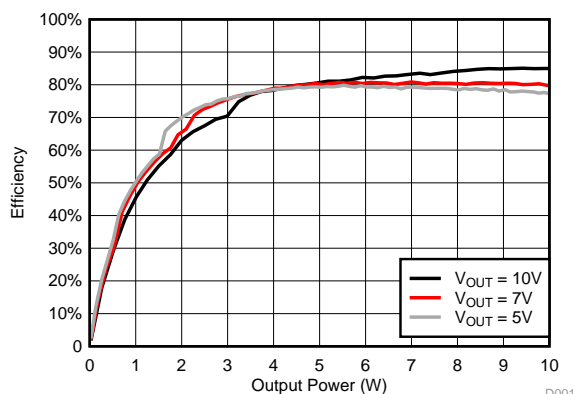

D001



Table of Contents

1 Features	1	8.4 Device Functional Modes	18
2 Applications	1	8.5 Register Maps	21
3 Description	1	9 Application and Implementation	27
4 Revision History	2	9.1 Application Information	27
5 Device Comparison Table	3	9.2 Typical Applications	27
6 Pin Configuration and Functions	3	10 Power Supply Recommendations	39
7 Specifications	5	11 Layout	40
7.1 Absolute Maximum Ratings	5	11.1 Layout Guidelines	40
7.2 ESD Ratings	5	11.2 Layout Example	40
7.3 Recommended Operating Conditions	5	12 Device and Documentation Support	41
7.4 Thermal Information	5	12.1 Receiving Notification of Documentation Updates	41
7.5 Electrical Characteristics	6	12.2 Community Resources	41
7.6 Typical Characteristics	8	12.3 Trademarks	41
8 Detailed Description	9	12.4 Electrostatic Discharge Caution	41
8.1 Overview	9	12.5 Glossary	41
8.2 Functional Block Diagram	11	13 Mechanical, Packaging, and Orderable Information	41
8.3 Feature Description	12		

4 Revision History

NOTE: Page numbers for previous revisions may differ from page numbers in the current version.

Changes from Revision B (March 2015) to Revision C	Page
• Changed From: WPC v1.1 To: WPC v1.2 throughout the document	1
• <i>Receiver Coil</i> section, changed the literature number reference From: SLUUBSS To: SLUUB55	30

Changes from Revision A (September 2014) to Revision B	Page
• Updated <i>Features</i> and <i>Description</i> to include 2S support	1
• Added 2S Battery Application to <i>Applications</i>	1
• Corrected R _{ILIM} threshold for EPT 0x02 to match <i>Electrical Characteristics</i>	15
• Corrected section numbering for <i>TMEM</i>	29
• Added design example section for Standalone 10-V Power Supply for 2S Charging System	35

Changes from Original (September 2014) to Revision A	Page
• Updated device status from product preview to production	1

5 Device Comparison Table

DEVICE	MODE	DESCRIPTION
bq51221	Dual (WPC v1.2, PMA)	Autonomous mode detection, I ² C control, adjustable output voltage
bq51020	WPC v1.2	Stand-alone solution, adjustable output voltage, highest system efficiency
bq51025	WPC v1.2, Proprietary 10 W	I ² C control, adjustable output voltage, 10-W maximum output power

6 Pin Configuration and Functions

YFP Package
42-Pin DSBGA
Top View

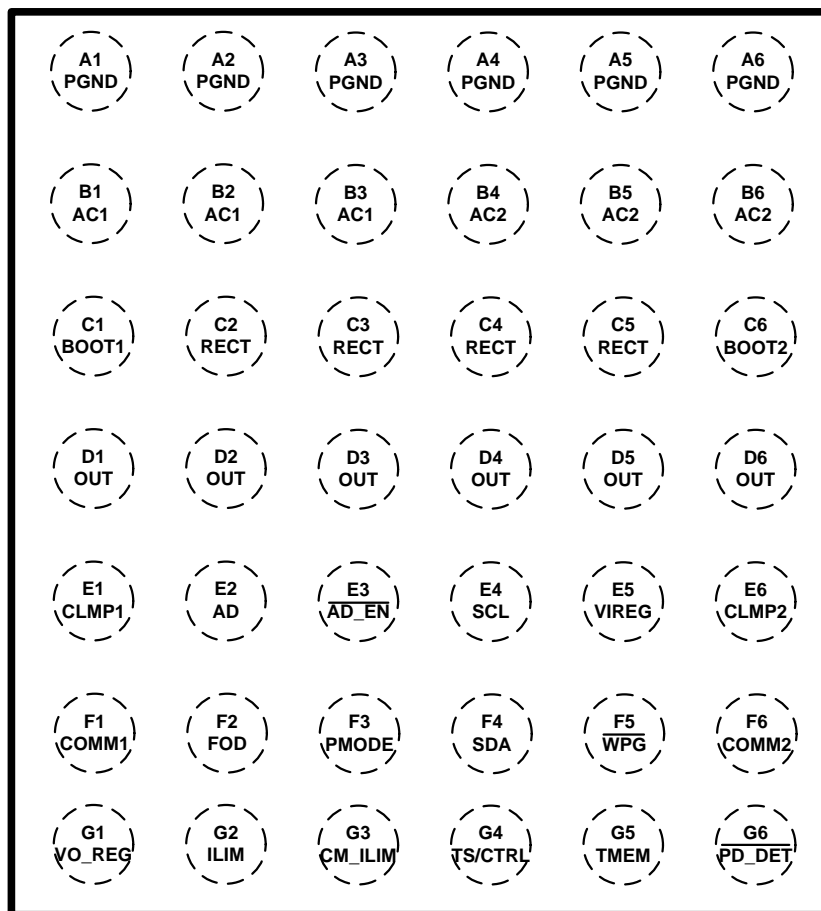

Pin Functions

PIN		TYPE	DESCRIPTION
NAME	NO.		
AC1	B1	I	AC input power from receiver resonant tank
	B2		
	B3		
AC2	B4	I	
	B5		
	B6		
AD	E2	I	Adapter sense pin
$\overline{\text{AD-EN}}$	E3	O	Push-pull driver for dual PFET circuit that can pass AD input to the OUT pin; used for adapter MUX control
BOOT1	C1	O	Bootstrap capacitors for driving the high-side FETs of the synchronous rectifier
BOOT2	C6	O	
CLAMP1	E1	O	Open-drain FETs used to clamp the secondary voltage by providing low impedance across secondary
CLAMP2	E6	O	
COMM1	F1	O	Open-drain FETs used to communicate with primary by varying reflected impedance
COMM2	F6	O	
CM_ILIM	G3	I	Enables communication current limit when pulled low or left floating.
FOD	F2	I	Input that is used for scaling the received power message
ILIM	G2	I/O	Output current or overcurrent level programming pin
OUT	D1	O	Output pin, used to deliver power to the load
	D2		
	D3		
	D4		
	D5		
	D6		
$\overline{\text{PD-DET}}$	G6	O	Open-drain output that allows user to sense when receiver is on transmitter
PGND	A1	—	Power and logic ground
	A2		
	A3		
	A4		
	A5		
	A6		
RECT	C2	O	Filter capacitor for the internal synchronous rectifier
	C3		
	C4		
	C5		
SCL	E4	I	SCL and SDA are used for I ² C communication. Connect to ground if not needed.
SDA	F4	I/O	
PMODE	F3	O	Indicates receiver mode of operation: Low = Proprietary 10-W mode, High = Low-power mode. Gate drive output for external current limit switch. Connect 5-M Ω resistor to ground. Leave floating if unused.
TMEM	G5	O	TMEM allows the capacitor to be connected to GND so energy from transmitter ping can be stored to retain memory of state.
TS/CTRL	G4	I	Temperature sense. Can be pulled high to send end power transfer (EPT) – charge complete to TX. Can be pulled low to send EPT – over temperature
VO_REG	G1	I	Sets the regulation voltage for output. Default value is 0.5 V.
VIREG	E5	I	Rectifier voltage feedback
$\overline{\text{WPG}}$	F5	O	Open-drain output that allows user to sense when power is transferred to load

7 Specifications

7.1 Absolute Maximum Ratings

over operating free-air temperature (unless otherwise noted)^{(1) (2)}

		MIN	MAX	UNIT
Input voltage	AC1, AC2	-0.8	20	V
	RECT, COMM1, COMM2, OUT, CLAMP1, CLAMP2, $\overline{\text{WPG}}$, $\overline{\text{PD_DET}}$	-0.3	20	
	AD, $\overline{\text{AD-EN}}$	-0.3	30	
	BOOT1, BOOT2	-0.3	20	
	SCL, SDA, PMODE, CM_ILIM, FOD, TS/CTRL, ILIM, TMEM, VIREG, VO_REG	-0.3	7	
Input current	AC1, AC2 (RMS)	2.5		A
Output current	OUT	2.5		A
Output sink current	$\overline{\text{WPG}}$, $\overline{\text{PD_DET}}$	15		mA
Output sink current	COMM1, COMM2	1		A
T _J	Junction temperature	-40	150	°C
T _{stg}	Storage temperature	-65	150	°C

(1) All voltages are with respect to the PGND pin, unless otherwise noted.

(2) Stresses beyond those listed under *Absolute Maximum Ratings* may cause permanent damage to the device. These are stress ratings only, and functional operation of the device at these or any other conditions beyond those indicated under *Recommended Operating Conditions* is not implied. Exposure to absolute-maximum-rated conditions for extended periods may affect device reliability.

7.2 ESD Ratings

		VALUE	UNIT
V _(ESD)	Electrostatic discharge	Human body model (HBM) 100 pF, 1.5 kΩ ⁽¹⁾	±2000
		Charged device model (CDM) ⁽²⁾	±500

(1) JEDEC document JEP155 states that 500-V HBM allows safe manufacturing with a standard ESD control process.

(2) JEDEC document JEP157 states that 250-V CDM allows safe manufacturing with a standard ESD control process.

7.3 Recommended Operating Conditions

over operating free-air temperature range (unless otherwise noted)

		MIN	MAX	UNIT
V _{RECT}	RECT voltage	4	11	V
I _{OUT}	Output current		2.0	A
I _{AD-EN}	Sink current		1	mA
I _{COMM}	COMMx sink current		500	mA
T _J	Junction temperature	0	125	°C

7.4 Thermal Information

THERMAL METRIC ⁽¹⁾		bq51025	UNIT
		YFP (DSBGA)	
		42 PINS	
R _{θJA}	Junction-to-ambient thermal resistance	49.7	°C/W
R _{θJC(top)}	Junction-to-case (top) thermal resistance	0.2	°C/W
R _{θJB}	Junction-to-board thermal resistance	6.1	°C/W
ψ _{JT}	Junction-to-top characterization parameter	1.4	°C/W
ψ _{JB}	Junction-to-board characterization parameter	6.0	°C/W

(1) For more information about traditional and new thermal metrics, see the [Semiconductor and IC Package Thermal Metrics](#) application report.

7.5 Electrical Characteristics

 over operating free-air temperature range (unless otherwise noted), $I_{LOAD} = I_{OUT}$

PARAMETER		TEST CONDITIONS	MIN	TYP	MAX	UNIT
V_{UVLO}	Undervoltage lockout	V_{RECT} : 0 to 3 V		2.8	2.9	V
$V_{HYS-UVLO}$	Hysteresis on UVLO	V_{RECT} : 3 to 2 V		393		mV
$V_{RECT-OVP}$	Input overvoltage threshold	V_{RECT} : 5 to 16 V	14.6	15.1	15.6	V
$V_{HYS-OVP}$	Hysteresis on OVP	V_{RECT} : 16 to 5 V		1.5		V
$V_{RECT(REG)}$	Voltage at RECT pin set by communication with primary		$V_{OUT} + 0.120$	Lower of $V_{OUT} + 0.2$ or 11.0		V
$V_{RECT(TRACK)}$	V_{RECT} regulation above V_{OUT}	$V_{ILIM} = 1.2$ V		140		mV
$I_{LOAD-HYS}$	I_{LOAD} hysteresis for dynamic V_{RECT} thresholds as a % of I_{ILIM}	I_{LOAD} falling		4%		
$V_{RECT-DPM}$	Rectifier undervoltage protection, restricts I_{OUT} at $V_{RECT-DPM}$		3	3.1	3.2	V
$V_{RECT-REV}$	Rectifier reverse voltage protection with a supply at the output	$V_{RECT-REV} = V_{OUT} - V_{RECT}$, $V_{OUT} = 10$ V		8.8	9.2	V
QUIESCENT CURRENT						
$I_{OUT(standby)}$	Quiescent current at the output when wireless power is disabled	$V_{OUT} \leq 5$ V, $0^\circ\text{C} \leq T_J \leq 85^\circ\text{C}$		20	35	μA
ILIM SHORT CIRCUIT						
$R_{ILIM-SHORT}$	Highest value of R_{ILIM} resistor considered a fault (short). Monitored for $I_{OUT} > 100$ mA	R_{ILIM} : 200 to 50 Ω . I_{OUT} latches off, cycle power to reset		215	230	Ω
$t_{DGL-Short}$	Deglintch time transition from ILIM short to I_{OUT} disable			1		ms
I_{ILIM_SC}	$I_{ILIM_SHORT,OK}$ enables the ILIM short comparator when I_{OUT} is greater than this value	I_{LOAD} : 0 to 200 mA	110	125	140	mA
$I_{ILIM-SHORT,OK HYS}$	Hysteresis for $I_{ILIM-SHORT,OK}$ comparator	I_{LOAD} : 200 to 0 mA		20		mA
I_{OUT-CL}	Maximum output current limit	Maximum I_{LOAD} that can be delivered for 1 ms when ILIM is shorted		3.7		A
OUTPUT						
V_{O_REG}	Feedback voltage set point	$I_{LOAD} = 2000$ mA, V_{O_REG} resistor divider ratio = 9:1	0.4968	0.5019	0.5077	V
		$I_{LOAD} = 1$ mA, V_{O_REG} resistor divider ratio = 9:1	0.4971	0.5017	0.5079	
		$I_{LOAD} = 1000$ mA, V_{O_REG} resistor divider ratio = 19:1	0.4977	0.5027	0.5091	
		$I_{LOAD} = 1$ mA, V_{O_REG} resistor divider ratio = 19:1	0.4978	0.5029	0.5098	
K_{ILIM}	Current programming factor for hardware short circuit protection	$R_{ILIM} = K_{ILIM} / I_{ILIM}$, where I_{ILIM} is the hardware current limit $I_{OUT} = 900$ mA		842		$\text{A}\Omega$
I_{OUT_RANGE}	Current limit programming range				2300	mA
I_{COMM}	Output current limit during communication	$I_{OUT} \geq 400$ mA		$I_{OUT} - 50$		mA
		100 mA $\leq I_{OUT} < 400$ mA		$I_{OUT} + 50$		
		$I_{OUT} < 100$ mA		200		
$t_{HOLD-OFF}$	Hold off time for the communication current limit during startup			1		s

Electrical Characteristics (continued)

over operating free-air temperature range (unless otherwise noted), $I_{LOAD} = I_{OUT}$

PARAMETER		TEST CONDITIONS	MIN	TYP	MAX	UNIT
TS/CTRL						
$V_{TS-Bias}$	TS bias voltage (internal)	$I_{TS-Bias} < 100 \mu A$ and communication is active (periodically driven, see $t_{TS/CTRL-Meas}$)		1.8		V
$V_{CTRL-HI}$	CTRL pin threshold for a high	$V_{TS/CTRL}$: 50 to 150 mV	90	105	120	mV
$T_{TS/CTRL-Meas}$	Time period of TS/CTRL measurements, when TS is being driven	TS bias voltage is only driven when power packets are sent			1700	ms
V_{TS-HOT}	Voltage at TS pin when device shuts down			0.38		V
THERMAL PROTECTION						
$T_{J(OFF)}$	Thermal shutdown temperature			155		°C
$T_{J(OFF-HYS)}$	Thermal shutdown hysteresis			20		°C
OUTPUT LOGIC LEVELS ON \overline{WPG}						
V_{OL}	Open-drain \overline{WPG} pin	$I_{SINK} = 5 \text{ mA}$			550	mV
$I_{OFF,STAT}$	\overline{WPG} leakage current when disabled	$V_{WPG} = 20 \text{ V}$			1	μA
COMM PIN						
$R_{DS-ON(COMM)}$	COMM1 and COMM2	$V_{RECT} = 2.6 \text{ V}$		1		Ω
f_{COMM}	Signaling frequency on COMMx pin for WPC			2.00		Kbps
$I_{OFF,COMM}$	COMMx pin leakage current	$V_{COMM1} = 20 \text{ V}$, $V_{COMM2} = 20 \text{ V}$			1	μA
CLAMP PIN						
$R_{DS-ON(CLAMP)}$	CLAMP1 and CLAMP2			0.5		Ω
ADAPTER ENABLE						
V_{AD-EN}	V_{AD} rising threshold voltage	$V_{AD} 0 \text{ V to } 5 \text{ V}$	3.5	3.6	3.8	V
$V_{AD-EN-HYS}$	V_{AD-EN} hysteresis	$V_{AD} 5 \text{ V to } 0 \text{ V}$		450		mV
I_{AD}	Input leakage current	$V_{RECT} = 0 \text{ V}$, $V_{AD} = 5 \text{ V}$			50	μA
$R_{AD-EN-OUT}$	Pullup resistance from $\overline{AD-EN}$ to OUT when adapter mode is disabled and $V_{OUT} > V_{AD}$	$V_{AD} = 0 \text{ V}$, $V_{OUT} = 5 \text{ V}$		230	350	Ω
$V_{AD-EN-ON}$	Voltage difference between V_{AD} and V_{AD-EN} when adapter mode is enabled	$V_{AD} = 5 \text{ V}$, $0^\circ C \leq T_J \leq 85^\circ C$	4	4.5	5	V
		$V_{AD} = 9 \text{ V}$, $0^\circ C \leq T_J \leq 85^\circ C$	3	6	7	V
SYNCHRONOUS RECTIFIER						
$I_{SYNC-EN}$	I_{OUT} at which the synchronous rectifier enters half synchronous mode	I_{OUT} : 200 to 0 mA		100		mA
$I_{SYNC-EN-HYST}$	Hysteresis for $I_{OUT,RECT-EN}$ (full-synchronous mode enabled)	I_{OUT} : 0 to 200 mA		40		mA
$V_{HS-DIODE}$	High-side diode drop when the rectifier is in half synchronous mode	$I_{AC-VRECT} = 250 \text{ mA}$, and $T_J = 25^\circ C$		0.7		V
I²C						
V_{IL}	Input low threshold level SDA	$V(PULLUP) = 1.8 \text{ V}$, SDA			0.4	V
V_{IH}	Input high threshold level SDA	$V(PULLUP) = 1.8 \text{ V}$, SDA	1.4			V
V_{IL}	Input low threshold level SCL	$V(PULLUP) = 1.8 \text{ V}$, SCL			0.4	V
V_{IH}	Input high threshold level SCL	$V(PULLUP) = 1.8 \text{ V}$, SCL	1.4			V
	I ² C speed	Typical		100		kHz

7.6 Typical Characteristics

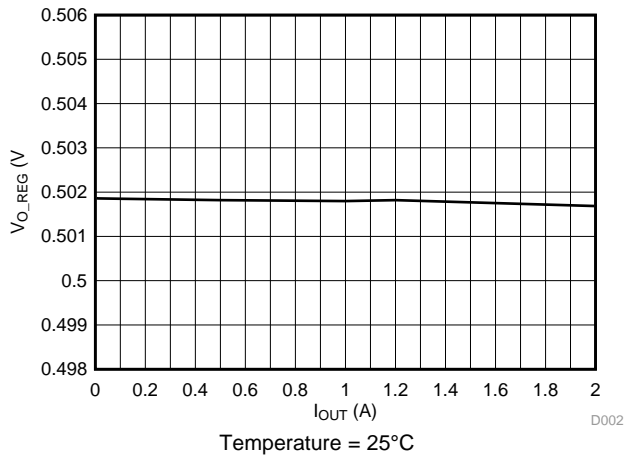

Figure 1. Output Regulation as a Function of Load

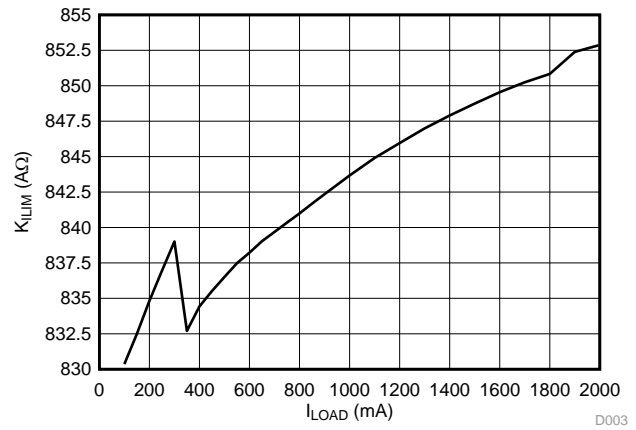

Figure 2. KILIM as a Function of Load Current

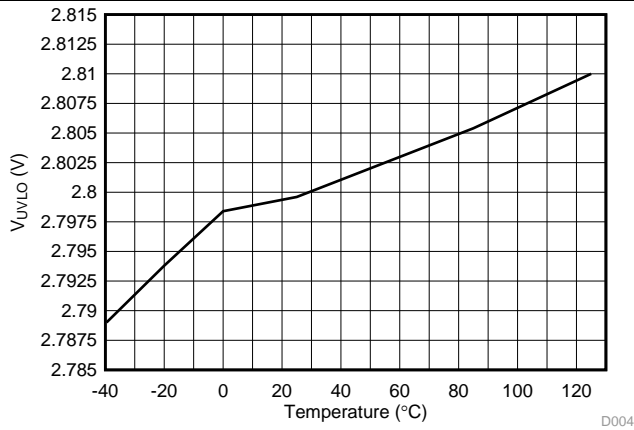

Figure 3. UVLO as a Function of Junction Temperature

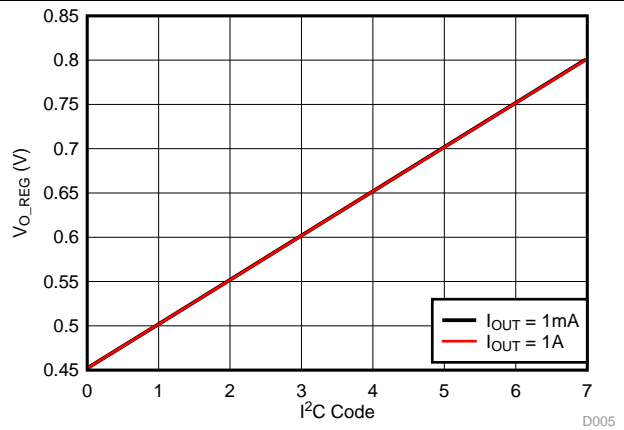

Figure 4. V_{O_REG} by Different I²C Codes, Resistor Divider Ratio = 9:1

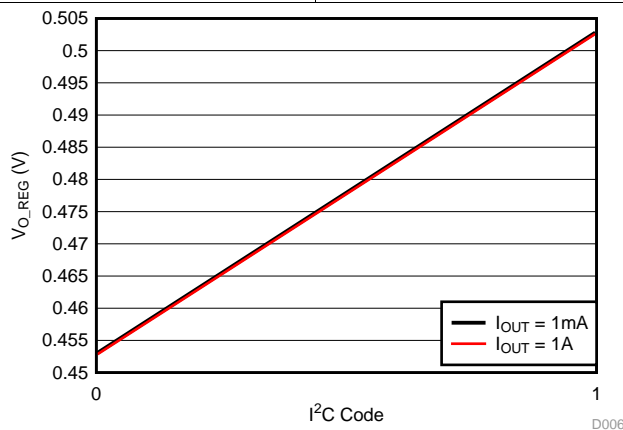

Figure 5. V_{O_REG} by Different I²C Codes, Resistor Divider Ratio = 19:1

8 Detailed Description

8.1 Overview

WPC-based wireless power systems consist of a charging pad (primary, transmitter) and the secondary-side equipment (receiver). The coils in the charging pad and secondary equipment magnetically couple to each other when the receiver is placed on the transmitter. Power is transferred from the primary to the secondary by transformer action between the coils. The receiver can achieve control over the amount of power transferred by getting the transmitter to change the field strength by changing the frequency, duty cycle, or voltage rail energizing the primary coil.

The receiver equipment communicates with the primary by modulating the load seen by the primary. This load modulation results in a change in the primary coil current or primary coil voltage, or both, which is measured and demodulated by the transmitter.

In WPC, the system communication is digital (packets that are transferred from the secondary to the primary). Differential biphasic encoding is used for the packets. The bit rate is 2 kb/s. Various types of communication packets are defined. These include identification and authentication packets, error packets, control packets, power usage packets, and end power transfer packets, among others.

The bq51025 incorporates a two-way proprietary authentication with the bq500215 primary controller that allows optimal power transfer and system performance up to 10-W output power while still complying with WPC v1.2 specifications.

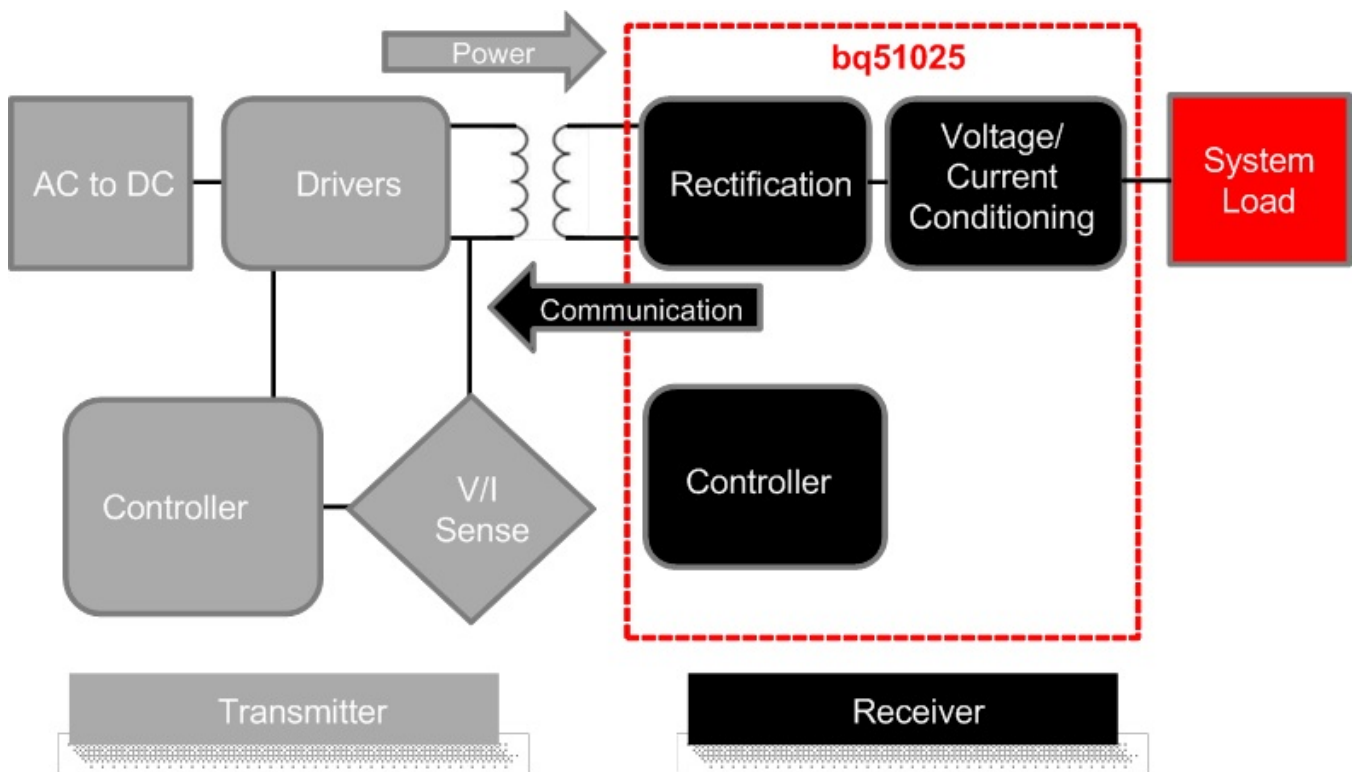

Figure 6. Wireless Power System Indicating the Functional Integration of the bq51025

The bq51025 device integrates fully-compliant WPC v1.2 communication protocol to streamline the wireless power receiver designs (no extra software development required). Other unique algorithms such as *Dynamic Rectifier Control* are integrated to provide best-in-class system efficiency while keeping the smallest solution size of the industry.

Overview (continued)

As a WPC system, when the receiver (shown in [Figure 6](#)) is placed on the charging pad, the secondary coil couples to the magnetic flux generated by the coil in the transmitter, which consequently induces a voltage in the secondary coil. The internal synchronous rectifier feeds this voltage to the RECT pin, which in turn feeds the LDO which feeds the output.

The bq51025 device identifies and authenticates itself to the primary using the COMMx pins, switching on and off the COMM FETs, and hence, switching in and out COMM capacitors. If the authentication is successful, the primary remains powered-up. Using a proprietary authentication protocol, the bq51025 determines if the 10-W bq500215 primary controller is powering the device, in which case the bq51025 device allows operation up to 10-W. If the bq51025 determines that a standard WPC-compliant transmitter is powering it, it allows operation up to 5-W. The bq51025 device measures the voltage at the RECT pin, calculates the difference between the actual voltage and the desired voltage $V_{RECT(REG)}$ and sends back error packets to the transmitter. This process goes on until the input voltage settles at $V_{RECT(REG) MAX}$. During a load change, the dynamic rectifier algorithm sets the target voltage between $V_{RECT(REG) MAX}$ and $V_{RECT(REG) MIN}$, as shown in [Table 1](#). This algorithm enhances the transient response of the power supply.

After the voltage at the RECT pin is at the desired value, the pass FET is enabled. The voltage control loop ensures that the output voltage is maintained at $V_{OUT(REG)}$, powering the downstream charger. The bq51025 device meanwhile continues to monitor the input voltage, and keeps sending control error packets (CEP) to the primary, on average, every 250 ms. If a large transient occurs, the feedback to the primary speeds up to 32-ms communication periods to converge on an operating point in less time.

8.2 Functional Block Diagram

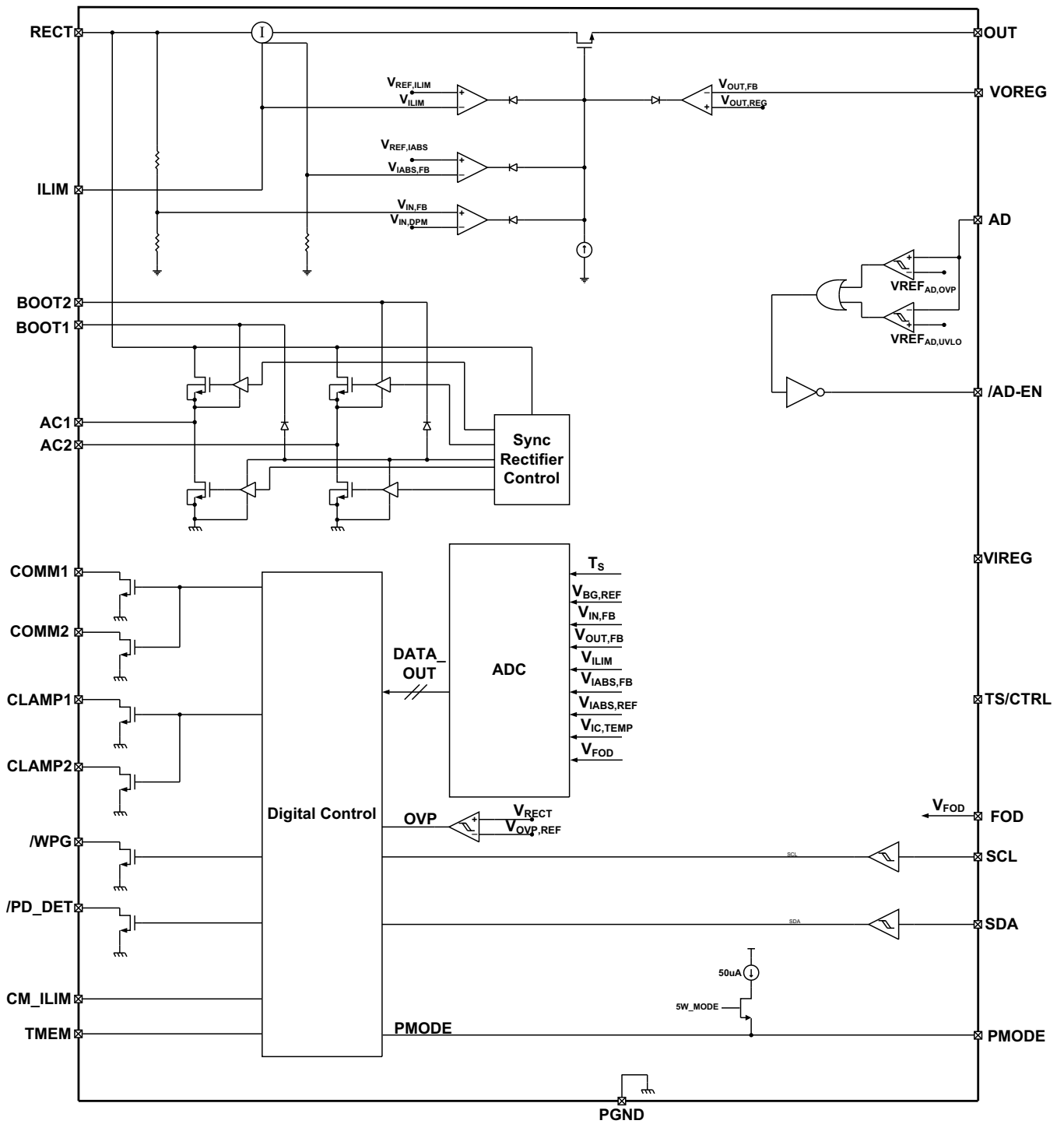

Copyright © 2016, Texas Instruments Incorporated

8.3 Feature Description

8.3.1 Dynamic Rectifier Control

The *Dynamic Rectifier Control* algorithm offers the end-system designer optimal transient response for a given maximum output current setting. This is achieved by providing enough voltage headroom across the internal regulator (LDO) at light loads in order to maintain regulation during a load transient. The WPC system has a relatively slow global feedback loop where it can take up to 150 ms to converge on a new rectifier voltage target. Therefore, a transient response depends on the loosely-coupled transformer's output-impedance profile. The *Dynamic Rectifier Control* allows for a 1.5-V change in rectified voltage before the transient response is observed at the output of the internal regulator (output of the bq51025 device). A 1-A application allows up to a 2-Ω output impedance. [Figure 13](#) shows the *Dynamic Rectifier Control* behavior during active power transfer.

8.3.2 Dynamic Power Scaling

The *Dynamic Power Scaling* feature allows for the loss characteristics of the bq51025 device to be scaled based on the maximum expected output power in the end application. This effectively optimizes the efficiency for each application. This feature is achieved by scaling the loss of the internal LDO based on a percentage of the maximum output current. Note that the maximum output current is set by the K_{ILIM} term and the R_{ILIM} resistance (where $R_{ILIM} = K_{ILIM} / I_{ILIM}$). The flow diagram in [Figure 13](#) shows how the rectifier is dynamically controlled (*Dynamic Rectifier Control*) based on the voltage level at the ILIM pin (V_{ILIM}). This voltage represents a fixed percentage of the I_{ILIM} setting. [Table 1](#) summarizes how the rectifier behavior is dynamically adjusted based on two different R_{ILIM} settings. [Table 1](#) is shown for I_{MAX} , which is the maximum operating output current and is typically lower than I_{ILIM} (about 20% lower). See [RILIM Calculations](#) for more details on how to set I_{ILIM} .

Table 1. Dynamic Rectifier Regulation⁽¹⁾

Output Current Percentage (Low-Power Mode)	Output Current Percentage (Proprietary Mode)	Low Power (5-W) Mode $R_{ILIM} = 700 \Omega$ $I_{ILIM} = 0.6 \text{ A}$ ($I_{MAX} = 0.5 \text{ A}$)	Low Power (5-W) Mode $R_{ILIM} = 700 \Omega$ $I_{ILIM} = 1.2 \text{ A}$ ($I_{MAX} = 1 \text{ A}$)	Proprietary 10-W Mode $R_{ILIM} = 495 \Omega$ $I_{ILIM} = 1.7 \text{ A}$ ($I_{MAX} = 1.4 \text{ A}$)	$V_{RECT}^{(2)}$
0 to 10%	0 to 5%	0 to 0.05 A	0 to 0.05 A	0 to 0.070 A	$V_{OUT} + 2.0$
10 to 20%	5 to 10%	0.05 to 0.1 A	0.05 to 0.1 A	0.070 to 0.14 A	$V_{OUT} + 1.6$
20 to 40%	10 to 20%	0.1 to 0.2 A	0.1 to 0.2 A	0.14 to 0.28 A	$V_{OUT} + 0.6$
>40%	>20%	>0.2 A	>0.2 A	>0.28 A	$V_{OUT} + 0.12$

(1) $R_{OS} = \text{Open}$. The relation between V_{ILIM} and I_{ILIM} has some dependency on the R_{OS} value.

(2) V_{RECT} is regulated to a maximum of 11 V.

[Table 1](#) shows the shift in the *Dynamic Rectifier Control* behavior based on the two different R_{ILIM} settings. With the rectifier voltage (V_{RECT}) as the input to the internal LDO, this adjustment in the *Dynamic Rectifier Control* thresholds dynamically adjusts the power dissipation across the LDO where,

$$P_{DIS} = (V_{RECT} - V_{OUT}) \cdot I_{OUT} \quad (1)$$

[Figure 22](#) shows how the *Dynamic Power Scaling* feature reduces the V_{RECT} with increased load, allowing the post-regulation LDO to have maximum headroom at low load conditions for better load transient performance and minimal power dissipation at high loads. Note that this feature balances efficiency with optimal system transient response.

8.3.3 VO_REG Calculations

The bq51025 device allows the designer to set the output voltage by setting a feedback resistor divider network from the OUT pin to the VO_REG pin, as seen in [Figure 7](#). Select the resistor divider network so that the voltage at the VO_REG pin is 0.5 V (default setting) at the desired output voltage. The target VO_REG voltage can be changed through I²C by changing [Table 4](#)

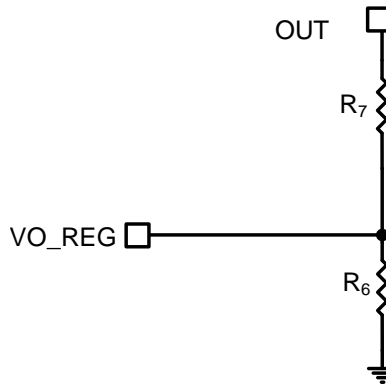

Figure 7. VO_REG Network

Choose the desired output voltage V_{OUT} and R_6 :

$$K_{VO} = \frac{0.5 \text{ V}}{V_{OUT}} \quad (2)$$

$$R_6 = \frac{K_{VO} \times R_7}{1 - K_{VO}} \quad (3)$$

8.3.4 RILIM Calculations

The bq51025 device includes a means of providing hardware overcurrent protection (I_{ILIM}) through an analog current regulation loop. The hardware current limit provides an extra level of safety by clamping the maximum allowable output current (for example, current compliance). The R_{ILIM} resistor size also sets the thresholds for the dynamic rectifier levels providing efficiency tuning per each application's maximum system current. The calculation for the total R_{ILIM} resistance is as follows:

$$R_{ILIM} = \frac{K_{ILIM}}{I_{ILIM}} \quad (4)$$

$$R_1 = R_{ILIM} - R_{FOD} \quad (5)$$

The R_{ILIM} allows for the ILIM pin to reach 1.2 V when operating in proprietary mode (up to 10-W output power) when the output current is equal to I_{ILIM} . When the receiver operates in standard WPC low-power mode, the ILIM pin voltage threshold is changed from 1.2 to 0.6 V, setting the low-power mode current limit to half of that at the proprietary mode setting.

In the case where having the current limit change by a factor of two between modes is not desired, the two current limit levels may be independently controlled in two ways:

- By programming the IO_REG level through I²C
- By changing the effective R_{ILIM} value for each mode by using an external switch controlled by the PMODE pin

To adjust the current limit for each mode through I²C, R_{ILIM} is chosen using Equation 4 where I_{ILIM} is the current limit for proprietary mode (that is, higher current setting). The host should first set the desired current limit value for low-power mode as a percentage of I_{ILIM} through the IO_REG bits and then disable the 2X current scaling by setting the I2C_ILIM bit in Table 5 and Table 6 respectively to enable programmability. By default, IO_REG is set to the highest current setting allowed by R_{ILIM} (that is, 100% of I_{ILIM}).

If I²C control is not available, the current limit for low power and proprietary modes can be set independently by shorting a portion of the R_1 resistance using an external switch as shown in Figure 8. R_{ILIM} is calculated using Equation 4, where I_{ILIM} is the desired current limit for proprietary mode. The resistance to set the current limit in low-power mode, R_{ILIM_LP} is calculated by Equation 6.

$$R_{ILIM_LP} = \frac{K_{ILIM}}{2 \times I_{ILIM_LP}} \quad (6)$$

where I_{ILIM_LP} is the desired current limit value in low-power mode

The value for R_{1_A} is given by $R_{ILIM_LP} - R_{FOD}$. The value of R_{1_B} is then $R_{ILIM} - R_{1_A} - R_{FOD}$. Note that with this method I_{ILIM} must be less than $2 \times I_{ILIM_LP}$

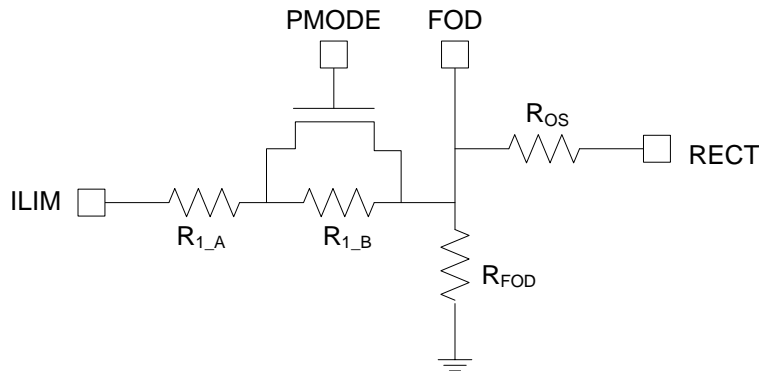

Figure 8. Current Limit Setting for bq51025 Using External Switch

When choosing I_{ILIM} , consider the following two possible operating conditions:

- If the user's application requires an output current equal to or greater than the external I_{ILIM} that the circuit is designed for (input current limit on the charger where the receiver device is tied higher than the external I_{ILIM}), ensure that the downstream charger is capable of regulating the voltage of the input into which the receiver device output is tied to by lowering the amount of current being drawn. This ensures that the receiver output does not drop to zero. Such behavior is referred to as VIN DPM in TI chargers. Unless such behavior is enabled on the charger, the charger pulls the output of the receiver device to ground when the receiver device enters current regulation.
- If the user's applications are designed to extract less than the I_{ILIM} , typical designs should leave a design margin of at least 10%, so that the voltage at ILIM pin reaches 1.2 V when 10% more than maximum current is drawn from the output. Such a design would have input current limit on the charger lower than the external ILIM of the receiver device.

However, in both cases, the charger must be capable of regulating the current drawn from the device to allow the output voltage to stay at a reasonable value. This same behavior is also necessary during the WPC communication. The following calculations show how such a design is achieved:

$$R_{ILIM} = \frac{K_{ILIM}}{1.1 \times I_{ILIM}} \quad (7)$$

$$R_1 = R_{ILIM} - R_{FOD}$$

$$\text{where } I_{LIM} \text{ is the hardware current limit} \quad (8)$$

When referring to the application diagram shown in [Typical Applications](#), R_{ILIM} is the sum of the R_1 and R_{FOD} resistance (that is, the total resistance from the ILIM pin to GND). R_{FOD} is chosen according to the application. To obtain the tool for calculating R_{FOD} , contact your TI representative. Use R_{FOD} to allow the receiver implementation to comply with WPC v1.2 requirements related to received power accuracy.

8.3.5 Adapter Enable Functionality

The bq51025 device can also help manage the multiplexing of adapter power to the output and can shut off the TX when the adapter is plugged in and is above the V_{AD-EN} . After the adapter is plugged in and the output turns off, the RX device sends an EPT to the TX. In this case, the $\overline{AD_EN}$ pins are then pulled to approximately 4 V below AD, which allows the device to turn on the back-to-back PMOS connected between AD and OUT (see [Figure 32](#)).

Both the AD and $\overline{AD-EN}$ pins are rated at 30 V, while the OUT pin is rated at 20 V. Note that it is required to connect a back-to-back PMOS between AD and OUT so that voltage is blocked in both directions. Also, when AD mode is enabled, no load can be pulled from the RECT pin because this could cause an internal device overvoltage in the bq51025 device.

8.3.6 Turning Off the Transmitter

The WPC v1.2 specification allows the receiver to turn off the transmitter and put the system in a low-power standby mode. There are two different ways to accomplish this with the bq51025 device. The EPT charge complete (WPC) can be sent to the TX by pulling the TS pin high (above 1.4 V). The bq51025 device will then sense this and send the appropriate signal to the TX, thus putting the TX in a low-power standby mode.

8.3.6.1 WPC v1.2 EPT

The WPC allows for a special command to terminate power transfer from the TX-terminated EPT packet. The WPC v1.2 specifies the following reasons and their corresponding data field value in [Table 2](#).

Table 2. EPT Codes in WPC

Reason	Value	Condition ⁽¹⁾
Unknown	0x00	AD > 3.6 V
Charge complete	0x01	TS/CTRL > 1.4 V
Internal fault	0x02	$T_J > 150^{\circ}\text{C}$ or $R_{ILIM} < 215 \Omega$
Over temperature	0x03	$TS < V_{HOT}$, or $TS/CTRL < 100 \text{ mV}$ ⁽²⁾
Over voltage	0x04	V_{RECT} voltage does not converge and stays higher than target
Battery failure	0x06	Not sent
Reconfigure	0x07	Not sent
No response	0x08	Not sent

(1) The *Condition* column corresponds to the case where the bq51025 device sends the WPC EPT command.

(2) The $TS < V_{TS-HOT}$ condition refers to using an external thermistor for temperature control. The $TS/CTRL < 100\text{-mV}$ condition refers to driving the TS/CTRL pin from external GPIO.

8.3.7 Communication Current Limit

Communication current limit is a feature that allows for error-free communication to happen between the RX and TX in the WPC mode. This is done by decoupling the coil from the load transients by limiting the output current during communication with the TX. The communication current limit is set according to [Table 3](#). The communication current limit can be enabled by pulling CM_ILIM pin low or disabled by pulling the CM_ILIM pin high (>1.4 V). An internal pulldown enables communication current limit when the CM_ILIM pin is left floating.

Table 3. Communication Current Limit

I_{OUT}	Communication Current Limit
$0 \text{ mA} < I_{OUT} < 100 \text{ mA}$	None
$100 \text{ mA} < I_{OUT} < 400 \text{ mA}$	$I_{OUT} + 50 \text{ mA}$
$400 \text{ mA} < I_{OUT} < \text{Max current}$	$I_{OUT} - 50 \text{ mA}$

When the communication current limit is enabled, the amount of current that the load can draw is limited. If the charger in the system does not have a VIN-DPM feature, the output of the receiver collapses if communication current limit is enabled. Please note that power dissipation within the device will increase during current limiting, lowering overall system efficiency. To disable communication current limit, pull CM_ILIM pin high.

8.3.8 $\overline{\text{PD_DET}}$ and TMEM

$\overline{\text{PD_DET}}$ is an open-drain pin that goes low based on the voltage of the TMEM pin. When the voltage of TMEM is higher than 1.6 V, $\overline{\text{PD_DET}}$ is low. The voltage on the TMEM pin depends on capturing the energy from the digital ping from the transmitter and storing it on the C_5 capacitor in [Figure 9](#). After the receiver sends an EPT (charge complete), the transmitter shuts down and goes into a low-power mode. However, it continues to check if the receiver would like to renegotiate a power transfer by periodically performing the digital ping. The energy from the digital ping can be stored on the TMEM pin until the next digital ping refreshes the capacitor. The designer can choose a bleedoff resistor, R_{MEM} , in parallel with C_5 that sets the time constant so that the TMEM pin will fall below 1.6 V once the next ping timer expires. The duration between digital pings is indeterminate and depends on each transmitter manufacturer.

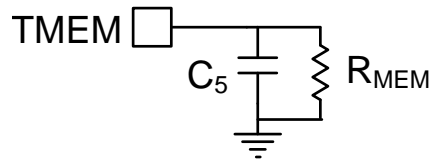
Figure 9. TMEM Configuration

Set capacitor on $C_5 = \text{TMEM}$ to 2.2 μF . Resistor R_{MEM} across C_5 can be set by understanding the duration between digital pings (t_{ping}). Set the resistor such that:

$$R_{\text{MEM}} = \frac{t_{\text{ping}}}{4 \times C_5} \quad (9)$$

$\overline{\text{PD_DET}}$ typically requires a pullup resistor to an external source. A higher current through the $\overline{\text{PD_DET}}$ pin may affect the output regulation of the device. To improve regulation, TI recommends pullup resistor values in the range of 15 to 100 k Ω .

8.3.9 TS/CTRL

The bq51025 device includes a ratiometric external temperature sense function. The temperature sense function has a low ratiometric threshold which represents a hot condition. TI recommends an external temperature sensor to provide safe operating conditions for the receiver product. This pin is best used for monitoring the surface that can be exposed to the end user (for example, place the negative temperature coefficient (NTC) resistor closest to the user touch point on the back cover). A resistor in series or parallel can be inserted to adjust the NTC to match the trip point of the device. The implementation in Figure 10 shows the series-parallel resistor implementation for setting the threshold at which $V_{\text{TS-HOT}}$ is reached. When the $V_{\text{TS-HOT}}$ threshold is reached, the device will send an EPT – overtemperature signal for a WPC transmitter.

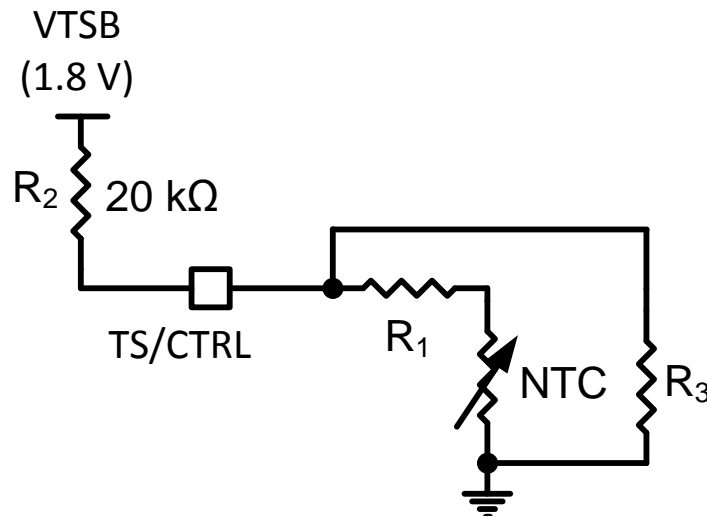

Figure 10. NTC Resistor Setup

Figure 10 shows a parallel resistor setup that can be used to adjust the trip point of $V_{\text{TS-HOT}}$. After the NTC is chosen and R_{NTCHOT} at $V_{\text{TS-HOT}}$ is determined from the data sheet of the NTC, use Equation 10 to calculate R_1 and R_3 . In many cases, depending on the NTC resistor, R_1 or R_3 can be omitted. To omit R_1 , set R_1 to 0, and to omit R_3 , set R_3 to 10 M Ω in the calculation.

$$V_{\text{TS-HOT}} = 1.8 \text{ V} \times \frac{\frac{(R_{\text{NTCHOT}} + R_1) \times R_3}{(R_{\text{NTCHOT}} + R_1) + R_3}}{\left(\frac{(R_{\text{NTCHOT}} + R_1) \times R_3}{(R_{\text{NTCHOT}} + R_1) + R_3}\right) + R_2} \quad (10)$$

8.3.10 PMODE Pin

Connect a 5-MΩ resistor to ground in order to use PMODE to indicate the receiver mode of operation. PMODE is high when in low-power mode and low in proprietary mode. This pin may be used to control the gate of an NMOS switch to change the R_{ILIM} , and hence, the current limit based on the maximum power allowed by the transmitter (10 W for bq500215, 5 W or less otherwise). This pin may be left floating if not used. and show the PMODE behavior during startup.

8.3.11 I²C Communication

The bq51025 device allows for I²C communication with the internal CPU. The I²C address for the device is 0x6C. In case the I²C is not used, ground SCL and SDA. See [Register Maps](#) for more information.

8.3.12 Input Overvoltage

If the input voltage suddenly increases in potential for some condition (for example, a change in position of the equipment on the charging pad), the voltage-control loop inside the bq51025 device becomes active, and prevents the output from going beyond $V_{OUT(REG)}$. The receiver then starts sending back error packets every 32 ms until the input voltage comes back to an acceptable level, and then maintains the error communication every 250 ms.

If the input voltage increases in potential beyond V_{RECT_OVP} , the device switches off the LDO and informs the primary to terminate power. In addition, a proprietary voltage protection circuit is activated by means of C_{CLAMP1} and C_{CLAMP2} that protects the device from voltages beyond the maximum rating of the device.

8.3.13 Alignment Aid Using Frequency Information

The bq51025 device provides the host through I²C with power signal frequency information that would enable it to determine the optimal alignment position on the charging surface of a frequency-controlled transmitter. For these WPC transmitters, the power signal frequency increases as the coupling between the primary and secondary coils increases. By finding the position in the charging pad that has the highest frequency, the host can determine that the best possible alignment with the transmitter coil has been achieved.

The bq51025 continuously stores a measurement of the power signal frequency in I²C register 0xFB to provide the host the information it needs to determine optimal placement. The power signal frequency is given by:

$$f_{AC} = 7259 \times \text{Code}^{-0.982}$$

where f_{AC} is the power signal frequency measured at the AC pins in kHz and code is the decimal value in the 0xFB register (11)

Figure 11 shows the expected register values across the frequency range.

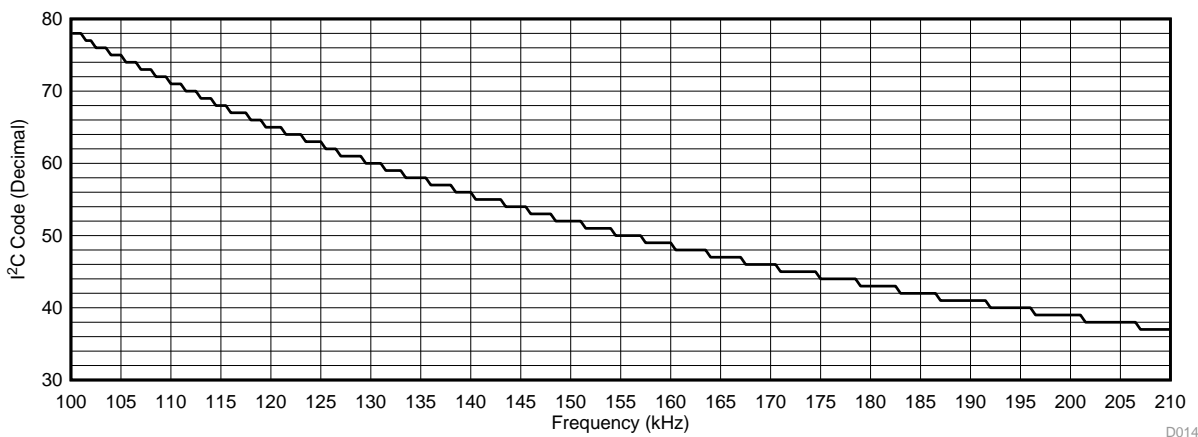

Figure 11. I²C Code vs Power Signal Frequency

8.4 Device Functional Modes

At startup operation, the bq51025 device must comply with proper handshaking to be granted a power contract from the WPC transmitter. The transmitter initiates the handshake by providing an extended digital ping after analog ping detects an object on the transmitter surface. If a receiver is present on the transmitter surface, the receiver then provides the signal strength, configuration, and identification packets to the transmitter (see volume 1 of the WPC specification for details on each packet). These are the first three packets sent to the transmitter. The only exception is if there is a true shutdown condition on the AD or TS/CTRL pins where the receiver shuts down the transmitter immediately. See [Table 2](#) for details. After the transmitter has successfully received the signal strength, configuration, and identification packets, the receiver is granted a power contract and is then allowed to control the operating point of the power transfer. With the use of the bq51025 device *Dynamic Rectifier Control* algorithm, the receiver informs the transmitter to adjust the rectifier voltage to approximately 8 V prior to enabling the output supply. For startup flow diagram details, see [Figure 12](#).

To operate in 10-W mode, the bq51025 device performs a proprietary handshaking procedure with the transmitter. If the transmitter (bq500215) responds to the bq51025 handshake, a 10-W power contract is granted and the bq51025 operates in 10-W mode, setting the proper output current limit and control. If there is no response from the transmitter, the bq51025 device defaults to 5-W mode operation.

Device Functional Modes (continued)

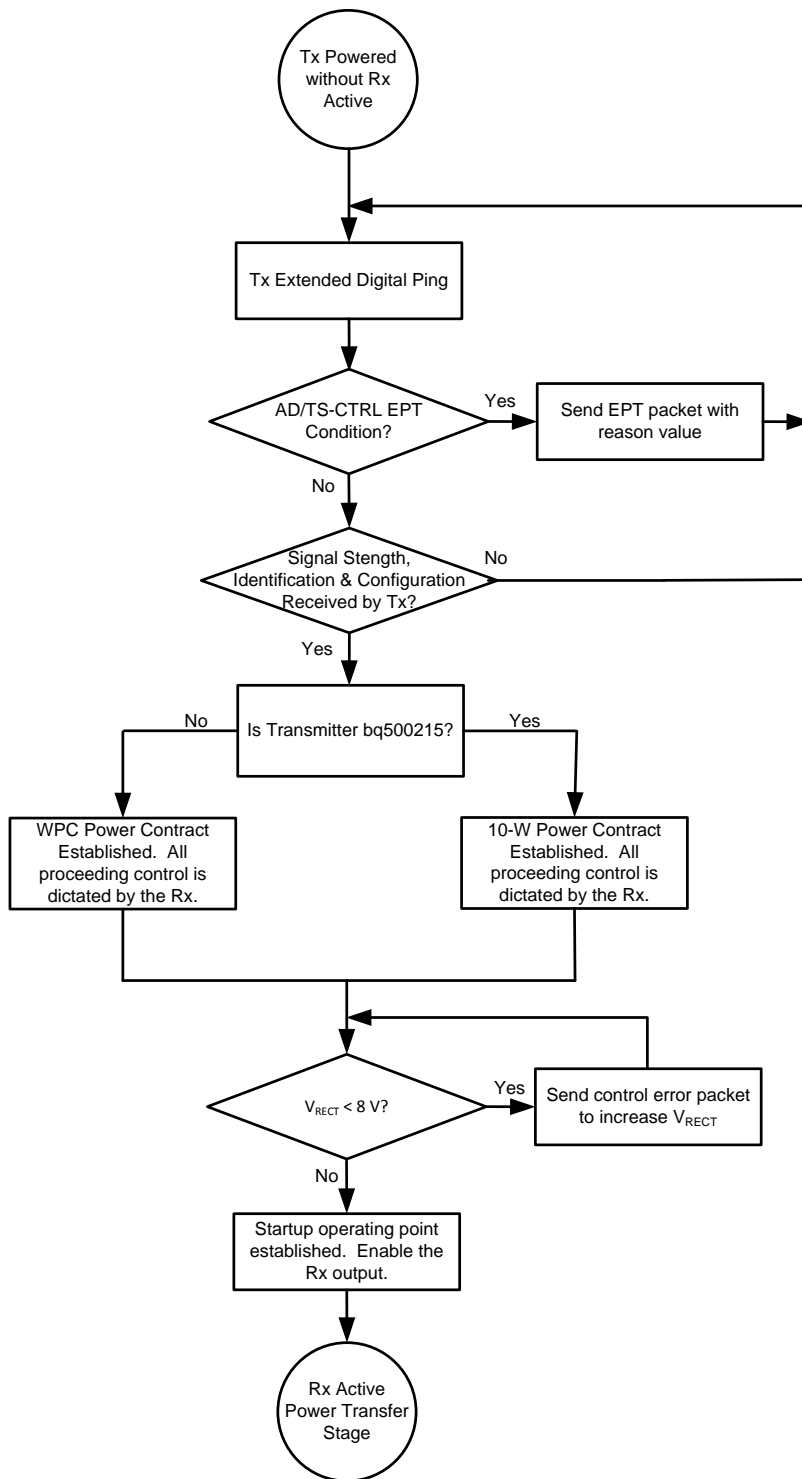

Figure 12. Wireless Power Startup Flow Diagram on WPC TX

Device Functional Modes (continued)

After the startup procedure is established, the receiver enters the active-power transfer stage (considered the main loop of operation). The *Dynamic Rectifier Control* algorithm determines the rectifier voltage target based on a percentage of the maximum output current level setting (set by K_{ILIM} and R_{ILIM}). The receiver sends control error packets to converge on these targets. As the output current changes, the rectifier voltage target dynamically changes. As a note, the feedback loop of the WPC system is relatively slow, it can take up to 150 ms to converge on a new rectifier voltage target. It should be understood that the instantaneous transient response of the system is open loop and dependent on the receiver coil output impedance at that operating point. The main loop also determines if any conditions in [Table 2](#) are true in order to discontinue power transfer. [Figure 13](#) shows the active-power transfer loop.

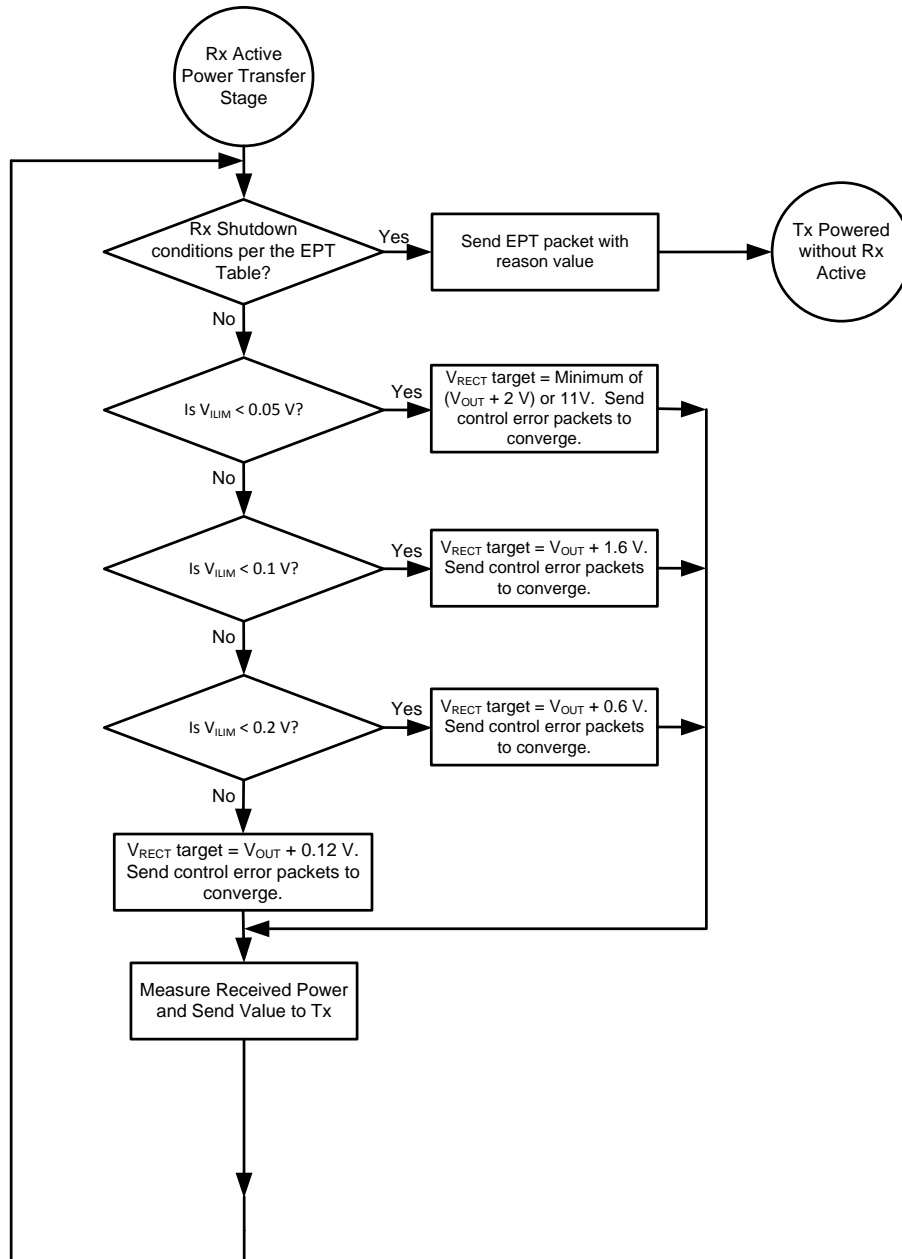

Figure 13. Active Power Transfer Flow Diagram on WPC TX

8.5 Register Maps

Locations 0x01 and 0x02 can be written at any time. Locations 0xE0 to 0xFF are only functional when $V_{RECT} > V_{UVLO}$. When V_{RECT} goes below V_{UVLO} , locations 0xE0 to 0xFF are reset.

8.5.1 Wireless Power Supply Current Register 1

Table 4. Wireless Power Supply Current Register 1 (READ / WRITE)

Memory Location: 0x01, Default State: 00000001			
BIT	NAME	READ / WRITE	FUNCTION
B7 (MSB)		Read / Write	Not used
B6		Read / Write	Not used
B5		Read / Write	Not used
B4		Read / Write	Not used
B3		Read / Write	Not used
B2	V_{OREG2}	Read / Write	450, 500, 550, 600, 650, 700, 750, or 800 mV ⁽¹⁾ Changes VO_REG target Default value 001
B1	V_{OREG1}	Read / Write	
B0	V_{OREG0}	Read / Write	

(1) Maximum output voltage is limited to 10 V. Maximum V_{O_REG} setting is 0.5 V when default output voltage is set to 10 V with external resistor divider (19:1 ratio)

8.5.2 Wireless Power Supply Current Register 2

Table 5. Wireless Power Supply Current Register 2 (READ / WRITE)

Memory Location: 0x02, Default State: 00000111			
BIT	NAME	READ / WRITE	FUNCTION
B7 (MSB)	JEITA	Read / Write	Not used
B6		Read / Write	Not used
B5	I_{TERM2}	Read / Write	Not used.
B4	I_{TERM1}	Read / Write	
B3	I_{TERM0}	Read / Write	
B2	I_{OREG2}	Read / Write	10%, 20%, 30%, 40%, 50%, 60%, 80%, and 100% of I_{LIM} current based on configuration 000, 001,111
B1	I_{OREG1}	Read / Write	
B0	I_{OREG0}	Read / Write	

8.5.3 Wireless Power Supply Current Register 3

Table 6. Wireless Power Supply Current Register 3 (READ / WRITE)

Memory Location: 0xF0, Reset State: 00000000			
BIT	NAME	READ / WRITE	FUNCTION
B7	Reserved	Read/Write	
B6	Reserved	Read / Write	
B5	Reserved	Read / Write	
B4	Reserved	Read / Write	
B3	Reserved	Read / Write	
B2	Reserved	Read / Write	
B1	I2C_ILIM	Read / Write	Set bit to 1 to disable 2x current limit scaling between low-power and proprietary modes. Must be set to 1 to correctly adjust the current limit for each mode through I ² C
B0	Reserved	Read / Write	

8.5.4 I²C Mailbox Register

Table 7. I²C Mailbox Register (READ / WRITE)

Memory Location: 0xE0, Reset State: 10000000			
BIT	NAME	READ / WRITE	FUNCTION
B7	USER_PKT_DONE	Read/Write	Set bit to 0 to send proprietary packet with header in 0xE2. CPU checks header to pick relevant payload from 0xF1 to 0xF4. This bit will be set to 1 after the user packet with the header in register 0xE2 is sent.
B6	USER_PKT_ERR	Read	00 = No error in sending packet 01 = Error: No transmitter present 10 = Illegal header found: packet will not be sent 11 = Error: Not defined yet
B5			
B4	FOD Mailer	Read / Write	Not used
B3	ALIGN Mailer	Read / Write	Setting this bit to 1 enables alignment aid mode where the CEP = 0 is sent until this bit is set to 0 (or CPU reset occurs)
B2	FOD Scaler	Read / Write	Not used, write to 0 if register is written
B1	Reserved	Read / Write	
B0	Reserved	Read / Write	

8.5.5 I²C Mailbox Register 2

Table 8. I²C Mailbox Register 2 (READ / WRITE)

Memory Location: 0xEF, Reset State: 00000000			
BIT	NAME	READ / WRITE	FUNCTION
B7	<u>P</u> MODE	Read	Power mode 0 = Low-power mode 5 W 1 = Proprietary 10 W
B6	Reserved	Read / Write	
B5	Reserved	Read / Write	
B4	Reserved	Read / Write	
B3	Reserved	Read / Write	
B2	Reserved	Read / Write	
B1	Reserved	Read / Write	
B0	Reserved	Read / Write	

8.5.6 I²C Mailbox Register 3

Table 9. I²C Mailbox Register 3 (READ)

Memory Location: 0xFB, Reset State: 00000000			
BIT	NAME	READ / WRITE	FUNCTION
B7	FREQ7	Read	Power signal frequency. See Equation 11 for calculation.
B6	FREQ6	Read	
B5	FREQ5	Read	
B4	FREQ4	Read	
B3	FREQ3	Read	
B2	FREQ2	Read	
B1	FREQ1	Read	
B0	FREQ0	Read	

8.5.7 Wireless Power Supply FOD RAM

Table 10. Wireless Power Supply FOD RAM (READ / WRITE)

Memory Location: 0xE1, Reset State: 00000000 ⁽¹⁾			
BIT	NAME	READ / WRITE	FUNCTION
B7 (MSB)	ESR_ENABLE	Read / Write	Enables I ² C based ESR in received power, Enable = 1, Disable = 0
B6	OFF_ENABLE	Read / Write	Enables I ² C based offset power, Enable = 1, Disable = 0
B5	R _{FOD5}	Read / Write	000 = 0 mW 001 = 78 mW 010 = 156 mW 011 = 234 mW 100 = 312 mW 101 = 390 mW 110 = 468 mW 111 = 546 mW The value is added to received power message
B4	R _{FOD4}	Read / Write	
B3	R _{FOD3}	Read / Write	
B2	R _{FOD2}	Read / Write	
B1	R _{FOD1}	Read / Write	000 = ESR 001 = ESR 010 = ESR × 2 011 = ESR × 3 100 = ESR × 4 101 = ESR 110 = ESR 111 = ESR × 0.5
B0	R _{FOD0}	Read / Write	

(1) A non-zero value changes the I²R calculation resistor and offset in the received power calculation by a factor shown in the table.

8.5.8 Wireless Power User Header RAM

Table 11. Wireless Power User Header RAM (WRITE)

Memory Location: 0xE2, Reset State: 00000000 ⁽¹⁾	
BIT	READ / WRITE
B7 (MSB)	Read / Write
B6	Read / Write
B5	Read / Write
B4	Read / Write
B3	Read / Write
B2	Read / Write
B1	Read / Write
B0	Read / Write

(1) Must write a valid WPC v1.2 Proprietary Packet Header to enable proprietary package. Reserved headers (Control Error Packet, Received Power Packet, and so forth) may not be used. As soon as mailer (0xE0) is written, payload bytes are sent on the next available communication slot as determined by CPU. When payload is sent, the mailer (USER_PKT_DONE) is set to 1.

8.5.9 Wireless Power USER V_{RECT} Status RAM

Table 12. Wireless Power USER V_{RECT} Status RAM (READ)

Memory Location: 0xE3, Reset State: 00000000 Range – 0 to 12 V This register reads back the V _{RECT} voltage with LSB = 46 mV			
BIT	NAME	READ / WRITE	FUNCTION
B7 (MSB)	V _{RECT7}	Read	LSB = 46 mV
B6	V _{RECT6}	Read	
B5	V _{RECT5}	Read	
B4	V _{RECT4}	Read	
B3	V _{RECT3}	Read	
B2	V _{RECT2}	Read	
B1	V _{RECT1}	Read	
B0	V _{RECT0}	Read	

8.5.10 Wireless Power V_{OUT} Status RAM
Table 13. Wireless Power V_{OUT} Status RAM (READ)

Memory Location: 0xE4, Reset State: 00000000 This register reads back the V _{OUT} voltage with LSB = 46 mV			
BIT	NAME	Read / Write	FUNCTION
B7 (MSB)	VOUT7	Read / Write	LSB = 46 mV
B6	VOUT6	Read / Write	
B5	VOUT5	Read / Write	
B4	VOUT4	Read / Write	
B3	VOUT3	Read / Write	
B2	VOUT2	Read / Write	
B1	VOUT1	Read / Write	
B0	VOUT0	Read / Write	

8.5.11 Wireless Power Proprietary Mode REC PWR MSByte Status RAM
Table 14. Wireless Power Proprietary Mode REC PWR MSByte Status RAM (READ)⁽¹⁾

Memory Location: 0xE7, Reset State: 00000000 This register reads back the MSByte for received power in Proprietary 10-W Mode only		
BIT	Read / Write	
B7 (MSB)	Read / Write	
B6	Read / Write	
B5	Read / Write	
B4	Read / Write	
B3	Read / Write	
B2	Read / Write	
B1	Read / Write	
B0	Read / Write	

(1) For proprietary mode, Received power (mW) = (10000/128) × REC PWR MSByte + (10000 / (256 × 128)) × REC PWR LSByte

8.5.12 Wireless Power REC PWR LSByte Status RAM
Table 15. Wireless Power REC PWR LSByte Status RAM (READ)⁽¹⁾

Memory Location: 0xE8, Reset State: 00000000		
BIT	Read / Write	
B7 (MSB)	Read / Write	
B6	Read / Write	
B5	Read / Write	
B4	Read / Write	
B3	Read / Write	
B2	Read / Write	
B1	Read / Write	
B0	Read / Write	

(1) This register reads back the received power in low-power mode with LSB = 39 mW. In proprietary mode, this register reads back the LSByte for received power.

8.5.13 Wireless Power Prop Packet Payload RAM Byte 0
Table 16. Wireless Power Prop Packet Payload RAM Byte 0 (WRITE)

Memory Location: 0xF1, Reset State: 00000000		
BIT		Read / Write
B7 (MSB)		Read / Write
B6		Read / Write
B5		Read / Write
B4		Read / Write
B3		Read / Write
B2		Read / Write
B1		Read / Write
B0		Read / Write

8.5.14 Wireless Power Prop Packet Payload RAM Byte 1
Table 17. Wireless Power Prop Packet Payload RAM Byte 1 (WRITE)

Memory Location: 0xF2, Reset State: 00000000		
BIT		Read / Write
B7 (MSB)		Read / Write
B6		Read / Write
B5		Read / Write
B4		Read / Write
B3		Read / Write
B2		Read / Write
B1		Read / Write
B0		Read / Write

8.5.15 Wireless Power Prop Packet Payload RAM Byte 2
Table 18. Wireless Power Prop Packet Payload RAM Byte 2 (WRITE)

Memory Location: 0xF3, Reset State: 00000000		
BIT		Read / Write
B7 (MSB)		Read / Write
B6		Read / Write
B5		Read / Write
B4		Read / Write
B3		Read / Write
B2		Read / Write
B1		Read / Write
B0		Read / Write

8.5.16 Wireless Power Prop Packet Payload RAM Byte 3
Table 19. Wireless Power Prop Packet Payload RAM Byte 3 (WRITE)

Memory Location: 0xF4, Reset State: 00000000		
BIT		Read / Write
B7 (MSB)		Read / Write
B6		Read / Write
B5		Read / Write
B4		Read / Write
B3		Read / Write
B2		Read / Write
B1		Read / Write
B0		Read / Write

9 Application and Implementation

NOTE

Information in the following applications sections is not part of the TI component specification, and TI does not warrant its accuracy or completeness. TI's customers are responsible for determining suitability of components for their purposes. Customers should validate and test their design implementation to confirm system functionality.

9.1 Application Information

The bq51025 device complies with WPC v1.2 standard. There are several tools available for the design of the system. Obtain these tools by checking the product page at www.ti.com. The following sections detail how to design a WPC v1.2 mode RX system.

9.2 Typical Applications

9.2.1 WPC v1.2 Power Supply 7-V Output With 1.4-A Maximum Current With I²C

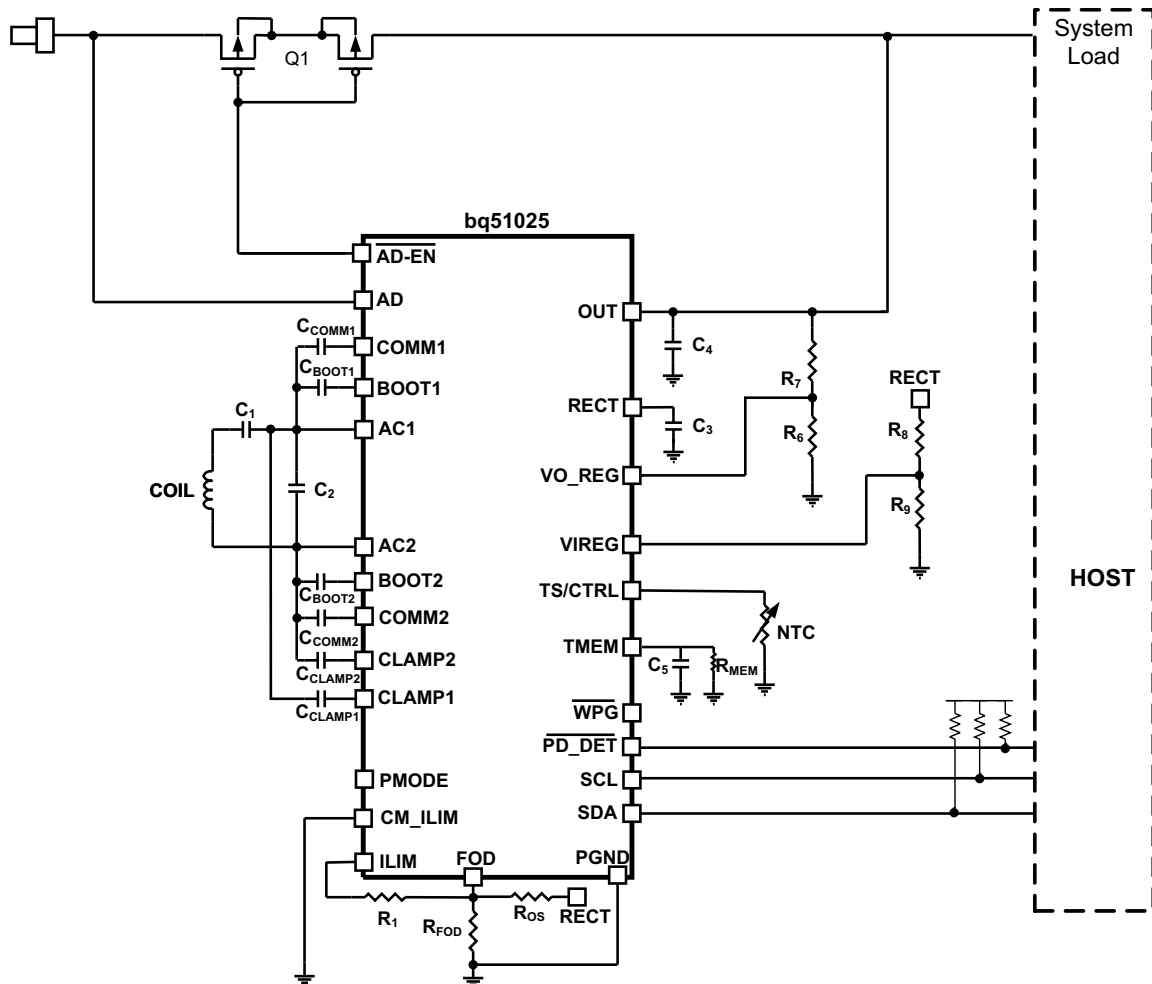

Copyright © 2016, Texas Instruments Incorporated

Figure 14. Schematic Using bq51025

Typical Applications (continued)

9.2.1.1 Design Requirements

Table 20 shows the design parameters.

Table 20. Design Parameters

DESIGN PARAMETER	EXAMPLE VALUE
V_{OUT}	7 V
$I_{OUT\ MAXIMUM}$	1.4 A

9.2.1.2 Detailed Design Procedure

To start the design procedure, determine the following:

- Output voltage
- Maximum output current

9.2.1.2.1 Output Voltage Set Point

The output voltage of the bq51025 device can be set by adjusting a feedback resistor divider network. The resistor divider network is used to set the voltage gain at the VO_REG pin. The device is intended to operate where the voltage at the VO_REG pin is set to 0.5 V. This value is the default setting and can be changed through I²C. In Figure 15, R₆ and R₇ are the feedback network for the output voltage sense.

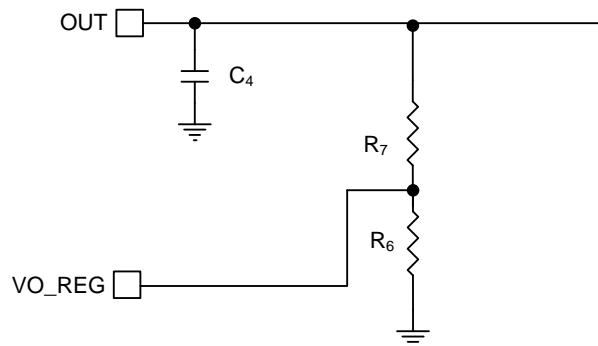

Figure 15. Voltage Gain for Feedback

$$K_{VO} = \frac{0.5\text{ V}}{V_{OUT}} \quad (12)$$

$$R_6 = \frac{K_{VO} \times R_7}{1 - K_{VO}} \quad (13)$$

Choose R₇ to be a standard value. In this case, take care to choose R₆ and R₇ to be fairly large values so as to not dissipate an excessive amount of power in the resistors and thereby lower efficiency.

K_{VO} is set to be 0.5 / 7 = 1/14, choose R₇ to be 130 kΩ, and thus R₆ to be 10 kΩ.

After R₆ and R₇ are chosen, the same values should be used on the VI_REG resistor divider (R₉ and R₈). This allows the device to regulate the rectifier voltage properly and accurately track the output voltage.

9.2.1.2.2 Output and Rectifier Capacitors

Set C₄ between 1 and 4.7 μF. This example uses 3.3 μF.

Set C₃ between 22 and 44 μF. This example uses 44 μF to minimize output ripple.

9.2.1.2.3 TMEM

Set C_5 to 2.2 μF . To determine the bleedoff resistor, the WPC transmitters (for which the $\overline{\text{PD_DET}}$ is being set for) needs to be determined. After the ping timing (time between two consecutive digital pings after EPT charge complete is sent) is determined, the bleedoff resistor R_{MEM} can be determined. This example uses TI transmitter EVMs as the use case. In this case, the time between pings is 5 s. To set the time constant using Equation 9, R_{MEM} is set to 560 k Ω .

9.2.1.2.4 Maximum Output Current Set Point

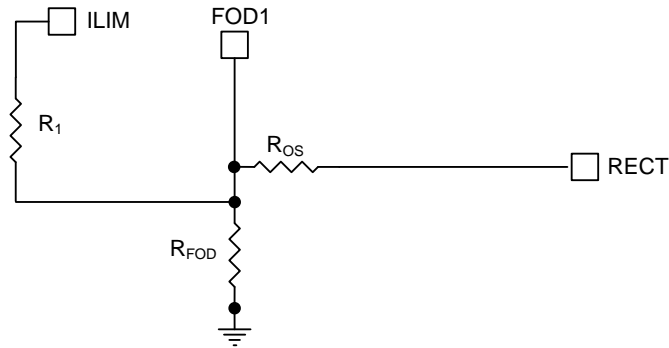

Figure 16. Current Limit Setting for bq51025

The bq51025 device includes a means of providing hardware overcurrent protection by means of an analog current regulation loop. The hardware current limit provides a level of safety by clamping the maximum allowable output current (for example, a current compliance). The R_{ILIM} resistor size also sets the thresholds for the dynamic rectifier levels, and thus providing efficiency tuning per each application's maximum system current. The calculation for the total R_{ILIM} resistance is as follows:

$$R_{\text{ILIM}} = \frac{K_{\text{ILIM}}}{I_{\text{ILIM}}} \quad (14)$$

$$R_1 = R_{\text{ILIM}} - R_{\text{FOD}} \quad (15)$$

The R_{ILIM} allows for the ILIM pin to reach 1.2 V at an output current equal to I_{ILIM} in 10-W mode and reach 0.6 V in 5-W mode. When choosing I_{ILIM} , consider two possible operating conditions:

- If the application requires an output current equal to or greater than external I_{LIM} that the circuit is designed for (input current limit on the charger where the RX is delivering power to is higher than the external I_{LIM}), ensure that the downstream charger is capable of regulating the voltage of the input into which the RX device output is tied to by lowering the amount of current being drawn. This ensures that the RX output does not collapse. Such behavior is referred to as VIN DPM in TI chargers. Unless such behavior is enabled on the charger, the charger pulls the output of the RX device to ground when the RX device enters current regulation.
- If the applications are designed to extract less than the I_{MAX} , typical designs should leave a design margin of at least 20% so that the voltage at ILIM pin reaches 1.2 V when 20% more than maximum current of the system (I_{MAX}) is drawn from the output of the RX. Such a design would have input current limit on the charger lower than the external current limit of the RX device.

In both cases, however, the charger must be capable of regulating the current drawn from the device to allow the output voltage to stay at a reasonable value. This same behavior is also necessary during the WPC v1.2 Communication. See [Communication Current Limit](#) for more details. The following calculations show how such a design is achieved:

$$R_{\text{ILIM}} = \frac{K_{\text{ILIM}}}{1.2 \times I_{\text{ILIM}}} \quad (16)$$

$$R_1 = R_{\text{ILIM}} - R_{\text{FOD}} \quad (17)$$

When referring to the application diagram shown in [Figure 16](#), R_{ILIM} is the sum of the R_1 and R_{FOD} resistance (that is, the total resistance from the ILIM pin to GND). R_{FOD} is chosen according to the FOD application note that can be obtained by contacting your TI representative. This is used to allow the RX implementation to comply with WPC v1.2 requirements related to received power accuracy.

Also note that in many applications, the resistor R_{OS} is necessary to comply with WPC v1.2 requirements. In such a case, the offset on the FOD pin from the voltage on R_{FOD} can cause a shift in the calculation that can reduce the expected current limit. Therefore, it is always a good idea to check the output current limit after FOD calibration is performed according to the FOD section. Unfortunately, because the RECT voltage is not deterministic, and depends on transmitter operation to a certain degree, it is not possible to determine R_1 with R_{OS} present in a deterministic manner.

In this example, set maximum current for the example to be 1.4 A at 10 W and 700 mA at 5-W mode. Set $I_{ILIM} = 1.7$ A to allow for the 20% margin.

$$R_{ILIM} = \frac{842}{1.7A} = 495\Omega \quad (18)$$

9.2.1.2.5 I²C

The I²C lines are used to communicate with the device. To enable the I²C, they can be pulled up to an internal host bus. The device address is 0x6C.

9.2.1.2.6 Communication Current Limit

Communication current limit allows the device to communicate with the transmitter in an error-free manner by decoupling the coil from load transients on the OUT pin during WPC communication. In some cases, this communication current limit feature is not desirable. In this design, the user enables the communication current limit by tying the CM_ILIM pin to GND. If this is not needed, the CM_ILIM pin can be tied to the OUT pin to disable the communication current limit. In this case, take care that the voltage on the CM_ILIM pin does not exceed the maximum rating of the pin.

9.2.1.2.7 Receiver Coil

The receiver coil design is the most open part of the system design. The choice of the receiver inductance, shape, and materials all intimately influence the parameters themselves in an intertwined manner. This design can be complicated and involves optimizing many different aspects; refer to the EVM user's guide ([SLUUB55](#)).

The typical choice of the inductance of the receiver coil for a 10-W, 7-V solution is between 15 and 16 μ H.

9.2.1.2.8 Series and Parallel Resonant Capacitors

Resonant capacitors, C_1 and C_2 , are set according to WPC specification.

The equations for calculating the values of the resonant capacitors are shown:

$$C_1 = \left[(f_S \times 2\pi)^2 \times L'_S \right]^{-1}$$

$$C_2 = \left[(f_D \times 2\pi)^2 \times L_S - \frac{1}{C_1} \right]^{-1} \quad (19)$$

Because the bq51025 can provide up to 10 W of output power, TI highly recommends that the resonant capacitors have very-low ESR and dissipate as little power as possible for better thermal performance. TI highly recommends NP0/C0G ceramic material capacitors.

9.2.1.2.9 Communication, Boot, and Clamp Capacitors

Set C_{COMMx} to a value ranging from $C_1 / 8$ to $C_1 / 3$. The higher the value of the communication capacitors, the easier it is to comply with the WPC specification. However, higher capacitors do lower the overall efficiency of the system. Make sure these are X7R ceramic material and have a minimum voltage rating of 25 V.

Set C_{BOOTx} as 15 nF. Make sure these are X7R ceramic material and have a minimum voltage rating of 25 V.

Set C_{CLAMPx} as 470 nF. Make sure these are X7R ceramic material and have a minimum voltage rating of 25 V.

9.2.1.3 Application Curves

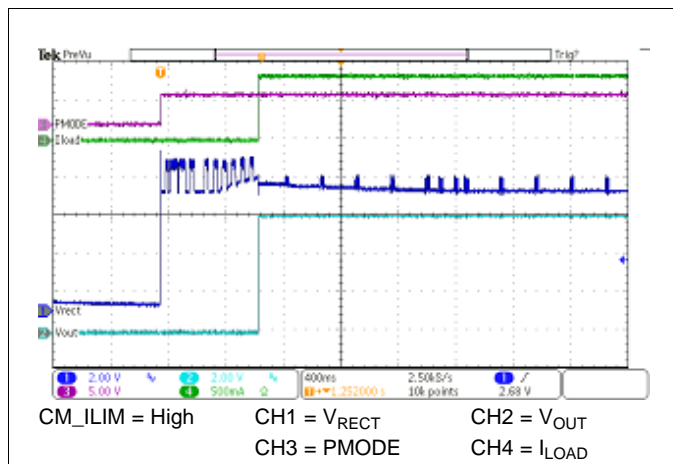

Figure 17. 7-V RX Start-Up With 9-Ω Load on a 5-W WPC TX

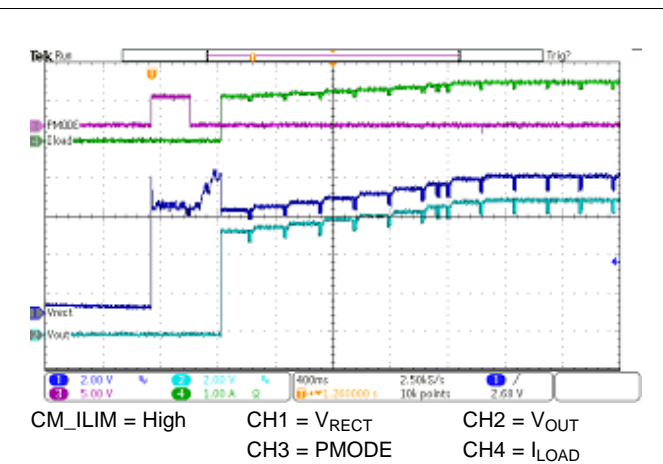

Figure 18. 7-V RX Start-Up With 5-Ω Load on a bq500215 TX

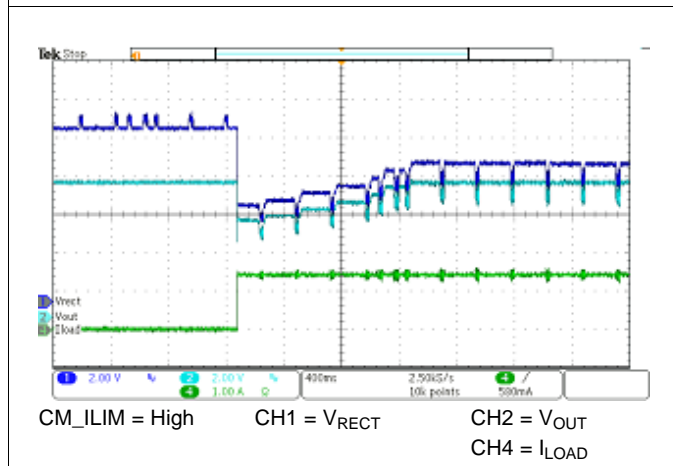

Figure 19. 0- to 1450-mA Step with 7-V RX on bq500215 TX

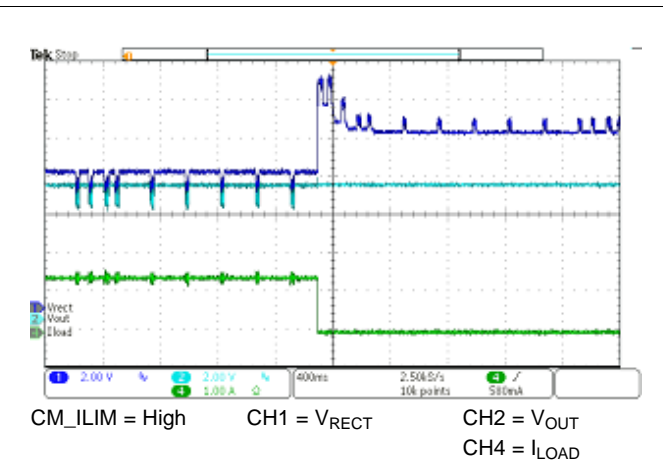

Figure 20. 1450- to 0-mA Load Dump with 7-V RX on bq500215 TX

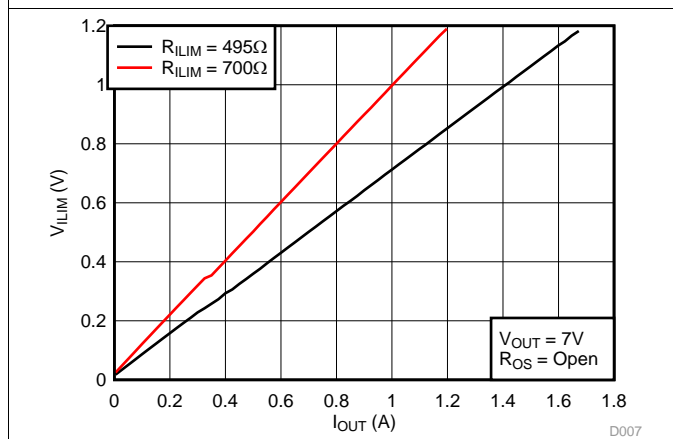

Figure 21. ILIM Voltage as a Function of Load Current

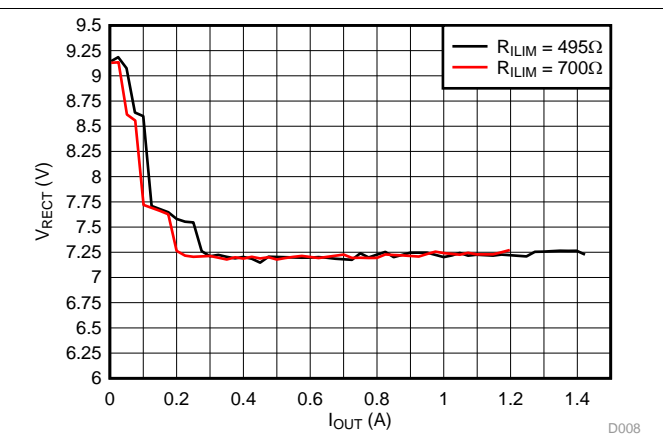

Figure 22. Rectifier Regulation as a Function of R_{ILIM} on bq500215 TX, 7-V RX

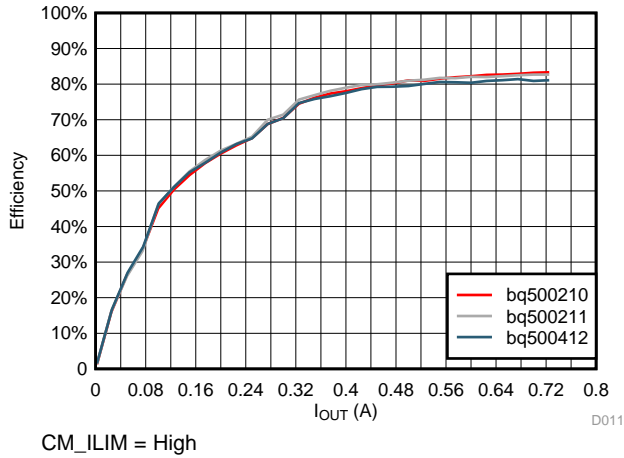

Figure 23. Efficiency on Various 5-W WPC TX, 7-V RX

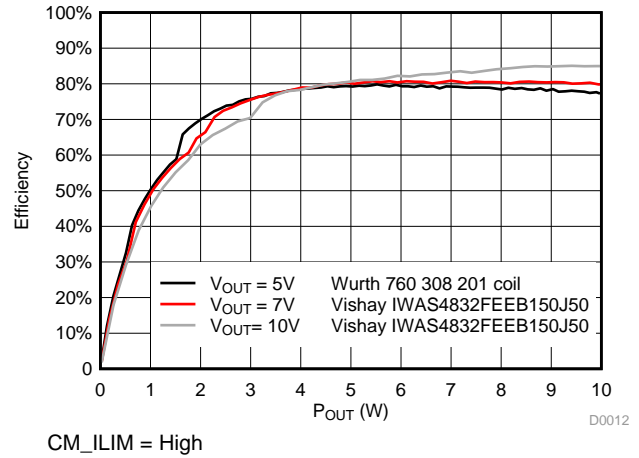

Figure 24. Efficiency on 10-W bq500215 TX

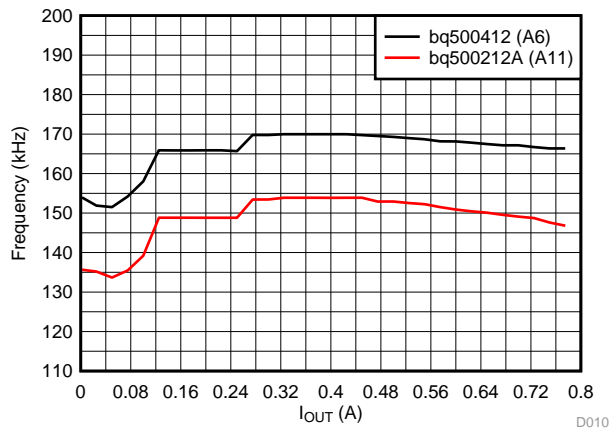

Figure 25. Frequency Range of 7-V, 5-W Mode on a WPC TX

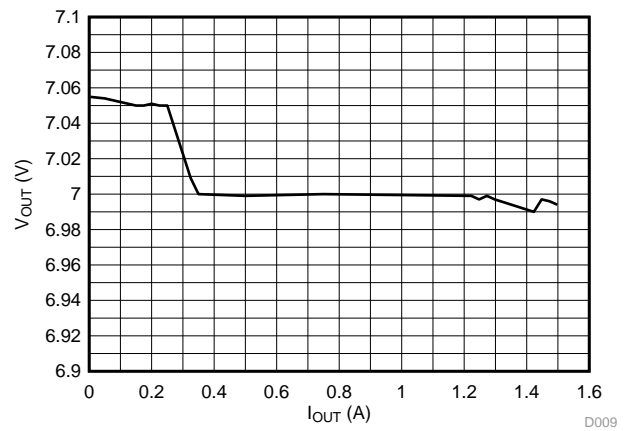

Figure 26. Output Regulation on bq500215 TX

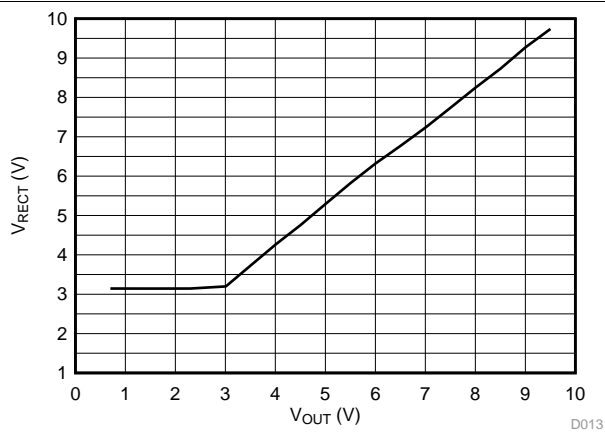

Figure 27. V_{RECT} Foldback in Current Limit on a WPC TX

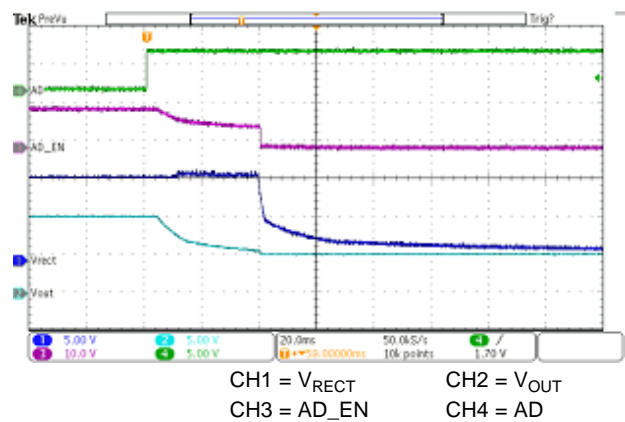

Figure 28. AD_EN Functionality upon 5-V USB Connection, 10-V RX, No Load

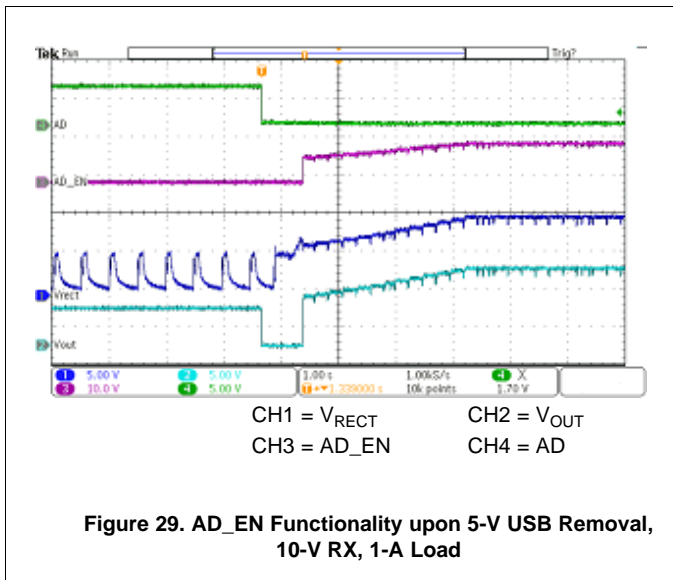

Figure 29. AD_EN Functionality upon 5-V USB Removal, 10-V RX, 1-A Load

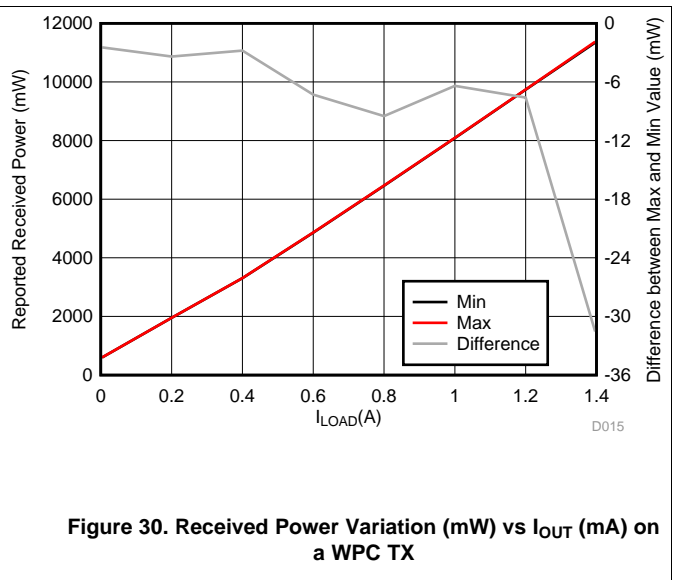

Figure 30. Received Power Variation (mW) vs I_{OUT} (mA) on a WPC TX

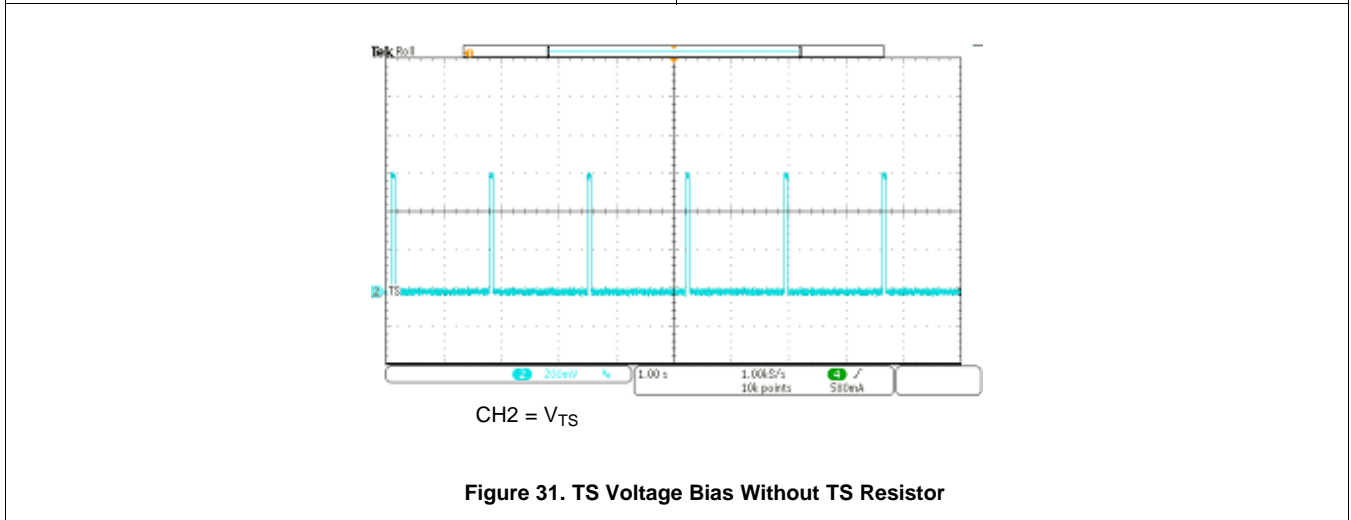
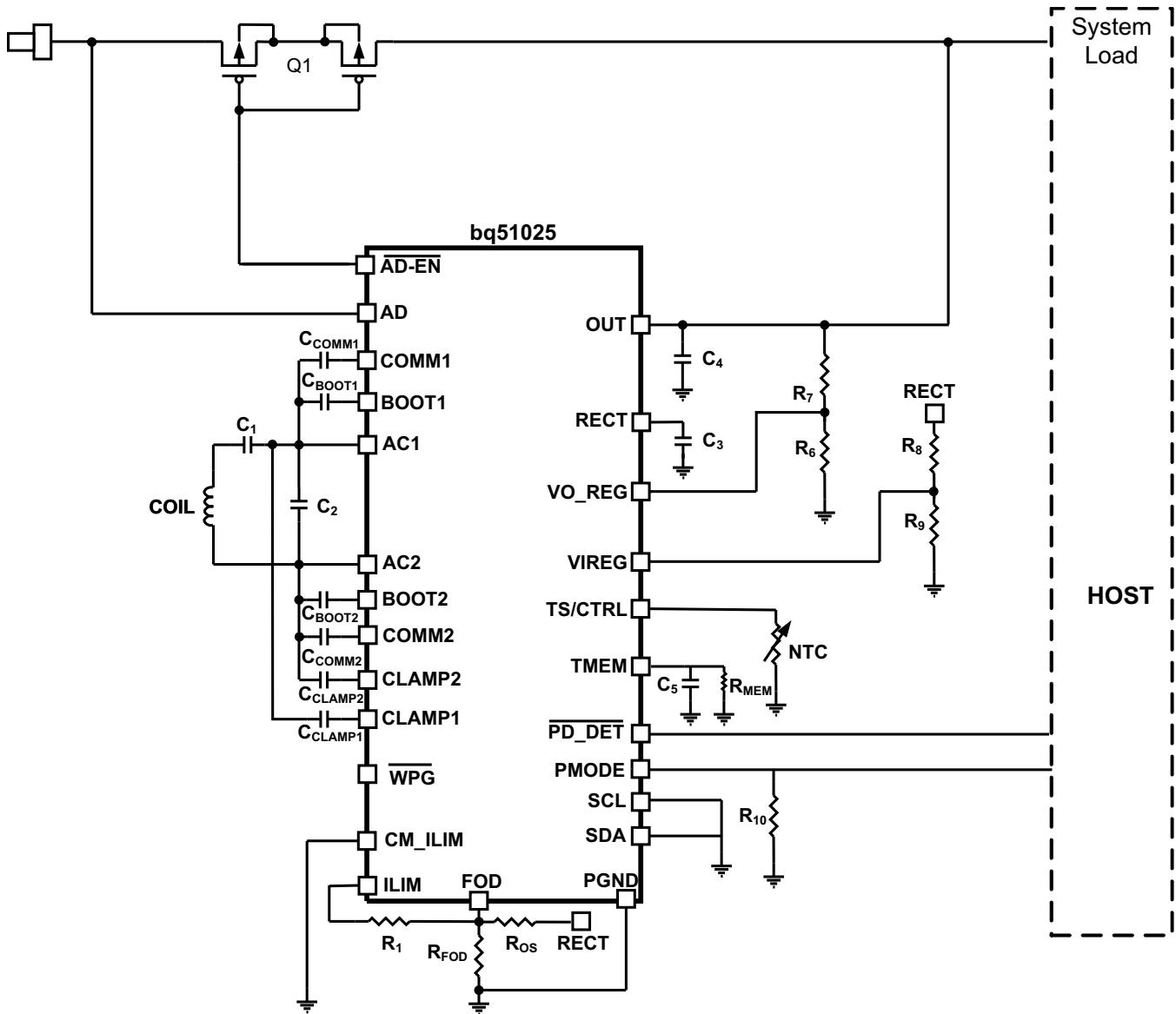

Figure 31. TS Voltage Bias Without TS Resistor

9.2.2 Standalone 10-V WPC v1.2 Power Supply With 1-A Maximum Output Current in System Board

When the bq5102x device is implemented as an embedded device on the system board, the same design procedure as for an I²C system should be used, but the I²C pins are to be connected to ground. The VO_REG and VIREG resistor dividers are chosen to achieve 10-V output and R_{ILIM} is chosen to allow a maximum current of 1 A (I_{ILIM} = 1.2 A for 20% margin). Refer to [WPC v1.2 Power Supply 7-V Output With 1.4-A Maximum Current With F²C](#) for details on how these resistor values are calculated.

A typical coil inductance for 10-V is between 15 and 17 μH. It is important to note that even if the same receiver coil and tuning as for a 7-V RX solution are used (see [Receiver Coil](#) and [Series and Parallel Resonant Capacitors](#)), the R_{FOD} and R_{OS} values need to be updated to accurately determine the received power.



Copyright © 2016, Texas Instruments Incorporated

Figure 32. bq51025 Embedded in a System Board

9.2.3 Standalone 10-V Power Supply With 1-A Maximum Output Current for 2S Charging System

For the bq51025 to work properly as a supply to a 2S charger, the bq51025 output voltage must not drop below the minimum input charging voltage of the charger, which may be around 9 V depending on the charger IC. In a WPC tuned Rx/TX system, the power delivered to the load may change during Rx/Tx communication due to the capacitive modulation when C_{COMM1} and C_{COMM2} are connected from AC1 and AC2 pins to ground. If the power delivered to the load decreases, the VRECT voltage will drop and so may VOUT. If the charger IC does not have input DPM. If the power delivered to the load does not change or increases for a given current, the VRECT voltage will increase and the bq51025 will regulate the voltage.

NOTE

The following design example is for a 2S charging system where the charger IC does not have input DPM feature.

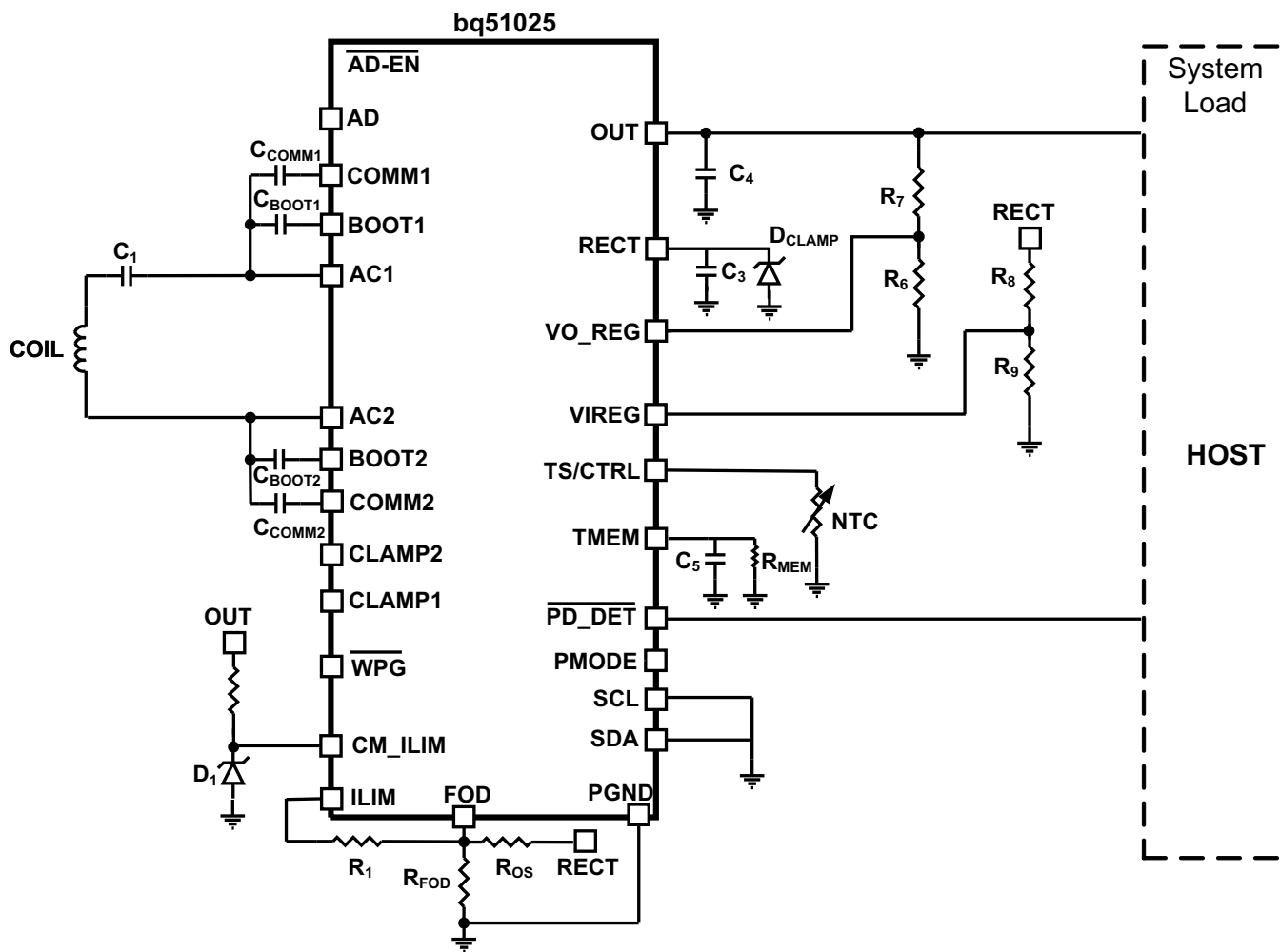

Copyright © 2016, Texas Instruments Incorporated

Figure 33. bq51025 Embedded in a 2S Battery System Board

9.2.3.1 Design Requirements

Table 21 shows the design parameters.

Table 21. Design Parameters

DESIGN PARAMETER	EXAMPLE VALUE
V_{OUT}	10 V
I_{OUT} MAXIMUM	1 A

9.2.3.2 Detailed Design Procedure

To start the design procedure, determine the following:

- Output voltage
- Maximum output current

9.2.3.2.1 Output Voltage Set Point

The output voltage of the bq51025 device can be set by adjusting a feedback resistor divider network as described in [Output Voltage Set Point](#). The ratio of VO_REG and $VIREG$ resistor dividers are chosen to achieve 10-V based on the 0.5-V feedback voltage. Following [Equation 12](#) and [Equation 13](#), R6 and R7 are selected to be 11.3K Ω - and 215-k Ω , respectively. The same values are used on R9 and R8 in the $VIREG$ divider.

9.2.3.2.2 Output and Rectifier Capacitors

Set C_4 to at least 3.3 μ F.

Set C_3 to at least 44 μ F to minimize output ripple. Use capacitors rated for 25 V or higher.

9.2.3.2.3 TMEM

Follow procedure described in [TMEM](#).

9.2.3.2.4 Maximum Output Current Set Point

Follow the procedure described in [Maximum Output Current Set Point](#).

9.2.3.2.5 I²C

Connect I²C lines to ground.

9.2.3.2.6 Communication Current Limit

Communication current limit must be disabled. Connect CM_ILIM pin to voltage supply making sure it does not exceed maximum absolute rating for the pin. If only the battery voltage is available, use a 5-V Zener diode (D_1) to clamp the voltage.

9.2.3.2.7 Receiver Coil

The receiver coil design is the most open part of the system design. The choice of the receiver inductance, shape, and materials all intimately influence the parameters themselves in an intertwined manner. This design can be complicated and involves optimizing many different aspects. The typical choice of the inductance of the receiver coil for a 10-W, 10-V solution is between 15 and 16 μ H.

9.2.3.2.8 Series Resonant Capacitors

In order for the bq51025 to work properly as a supply to a 2S charger, the bq51025 output voltage must not drop below the minimum input charging voltage of the charger, which may be around 9 V depending on the charger IC. In a WPC tuned Rx/Tx system, the power delivered to the load may change during Rx/Tx communication due to the capacitive modulation when C_{COMM1} and C_{COMM2} are connected from AC1 and AC2 pins to ground. If the power delivered to the load decreases, the V_{RECT} voltage will drop and so may V_{OUT} if the charger IC does not have VIN-DPM function. If the power delivered to the load does not change or increases for a given current, the V_{RECT} voltage will increase and the bq51025 will regulate the voltage to a fixed value. The following section discusses the tuning procedure to ensure that the output voltage level is maintained during communication when operating with a bq51025 based transmitter.

9.2.3.2.8.1 Tuning Procedure

NOTE

The following tuning procedure results in a system that is not compliant with WPC specification and is only designed to operate with a given bq500215 based transmitter.

1. Measure the effective self-inductance of the bq500215 based transmitter (primary) coil, L_P' , and receiver (secondary) coil, L_S' . The measurements must be done on the final charging system setup (that is, battery and any other friendly metal of the device is included as well as any cover material that determines the distance between the coil and charging surface). Make the measurement at the optimal alignment position.
2. Measure the mutual inductance, L_M and calculate the coupling factor given by:

$$k = \frac{L_M}{\sqrt{L_S' L_P'}} \quad (20)$$

3. A first-order approximation of the series capacitance is given by:

$$C_1 = \frac{1}{(2\pi f)^2 L_S' (1 - k^2) - \frac{k^2 L_S'}{C_P L_P'} - 4\pi f} \quad (21)$$

Where f is the operating frequency of the transmitter, which is 130 kHz and C_P is the transmitter resonant capacitance which is 247 nF.

4. Make sure C_1 as well as C_{COMM1} and C_{COMM2} are populated and place the receiver with best possible alignment on the transmitter and start power transfer. Using an oscilloscope, monitor the V_{RECT} voltage during communication at maximum load. If V_{RECT} decreases during communication, increase C_1 until the voltage remains flat. Note that the larger the V_{RECT} voltage increase is during communication at maximum load, the larger the losses on the device. The voltage increase in V_{RECT} is larger with lower load and lower coupling, so it is important to keep the V_{RECT} voltage as low as possible during communication at maximum load and coupling to maximize efficiency across charging area and load range. [Figure 35](#) and [Figure 36](#) show how the V_{RECT} voltage behavior after tuning

9.2.3.2.9 Communication, Boot, and Clamp Capacitors

Set C_{COMMx} to a value ranging from $C_1 / 8$ to $C_1 / 3$. Make sure these are X7R ceramic material and have a minimum voltage rating of 25 V. For this example 56-nF capacitors are chosen.

Set C_{BOOTx} as 15 nF. Make sure these are X7R ceramic material and have a minimum voltage rating of 25 V.

C_{CLAMPx} is not populated since a external clamping diode is used.

9.2.3.2.10 V_{RECT} Clamp

Connect a 12-V Zener diode (D_{CLAMP}) from V_{RECT} to ground. This diode prevents the rectifier voltage from overshoot above $V_{RECT-OVP}$ level, preventing unwanted resets during large load transients during communication.

9.2.3.3 Application Curves

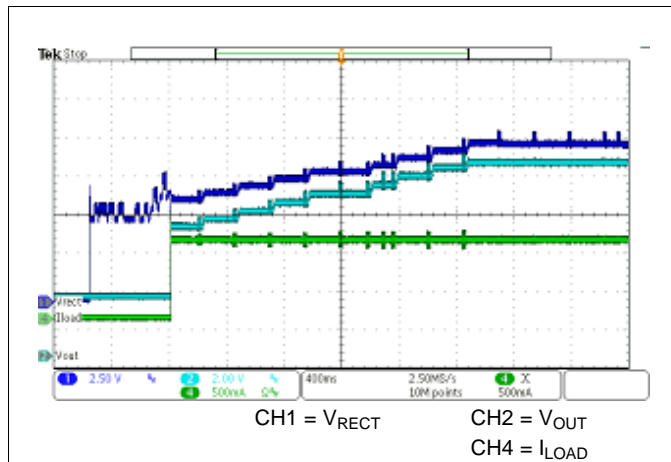

Figure 34. 10-V Tuned RX Start-Up With 1-A Load

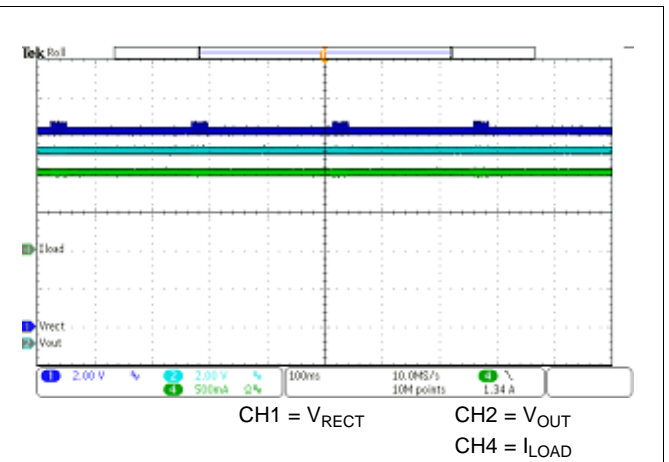

Figure 35. 10-V Tuned RX V_{OUT} at Center Position With 1-A Load

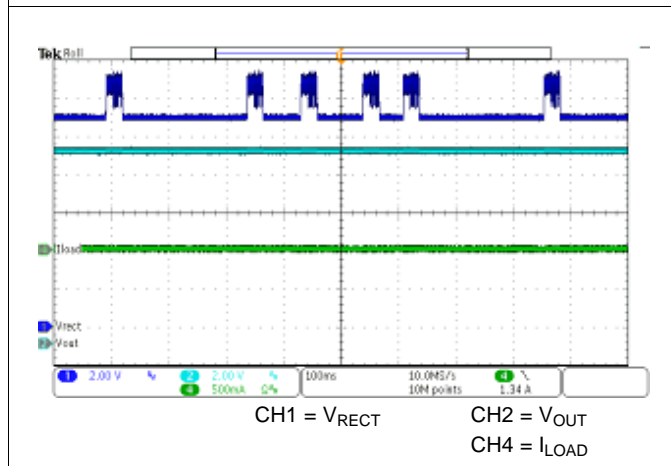

Figure 36. 10-V Tuned RX V_{OUT} at Center Position With No load

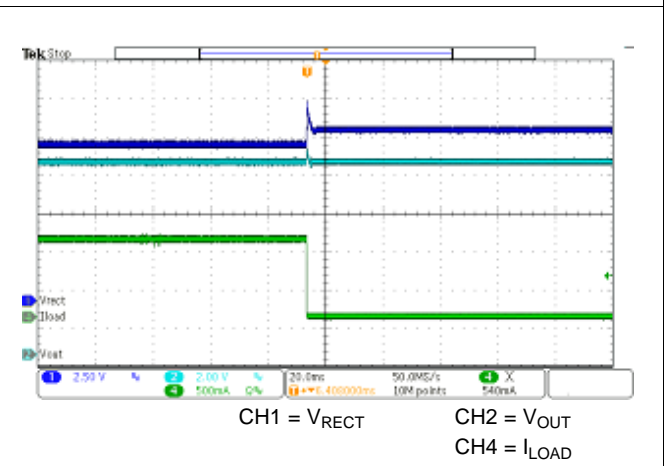

Figure 37. 1-A to 0-mA Load Dump With 10-V Tuned RX

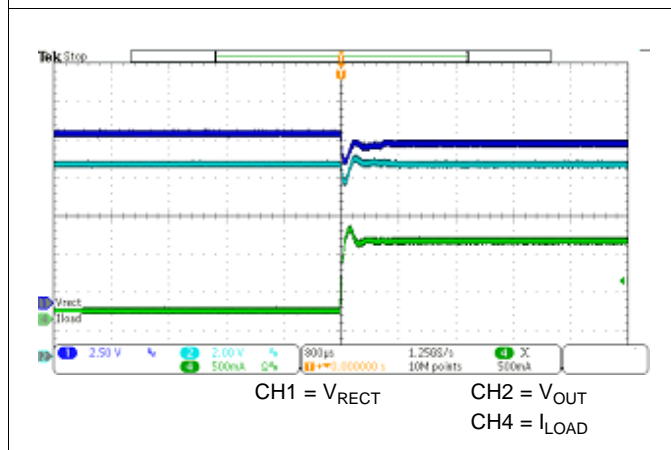

Figure 38. 100-mA to 1-A Load Transient With 10-V Tuned RX

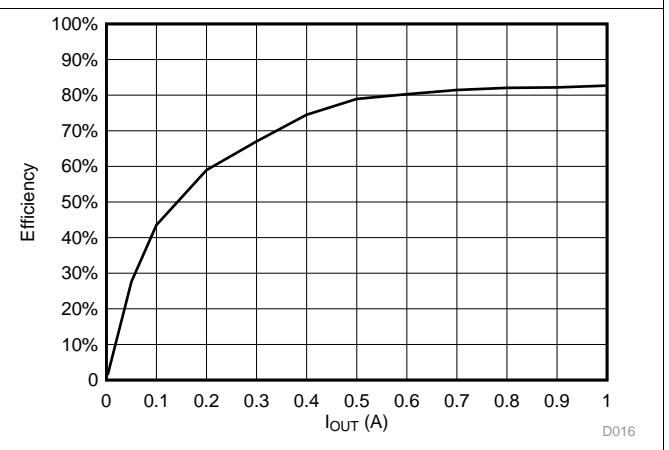

Figure 39. Efficiency With 10-V Tuned RX

10 Power Supply Recommendations

These devices are intended to be operated within the ranges shown in the [Recommended Operating Conditions](#). Because the system involves a loosely coupled inductor setup, the voltages produced on the receiver are a function of the inductances and the available magnetic field. Ensure that the design in the worst case keeps the voltages within the [Absolute Maximum Ratings](#).

11 Layout

11.1 Layout Guidelines

- Keep the trace resistance as low as possible on AC1, AC2, and OUT.
- Detection and resonant capacitors need to be as close to the device as possible.
- COMM, CLAMP, and BOOT capacitors need to be placed as close to the device as possible.
- Via interconnect on GND net is critical for appropriate signal integrity and proper thermal performance.
- High-frequency bypass capacitors need to be placed close to RECT and OUT pins.
- ILIM and FOD resistors are important signal paths and the loops in those paths to GND must be minimized.

Signal and sensing traces are the most sensitive to noise; the sensing signal amplitudes are usually measured in mV, which is comparable to the noise amplitude. Make sure that these traces are not being interfered by the noisy and power traces. AC1, AC2, BOOT1, BOOT2, COMM1, and COMM2 are the main source of noise in the board. These traces should be shielded from other components in the board. It is usually preferred to have a ground copper area placed underneath these traces to provide additional shielding. Also, make sure they do not interfere with the signal and sensing traces. The PCB should have a ground plane (return) connected directly to the return of all components through vias (two vias per capacitor for power-stage capacitors, one via per capacitor for small-signal components).

For a 1.4-A fast-charge current application, the current rating for each net is as follows:

- AC1 = AC2 = 2.2 A
- OUT = 2.5 A
- RECT = 200 mA (RMS)
- COMMx = 600 mA
- CLAMPx = 1000 mA
- All others can be rated for 10 mA or less.

11.2 Layout Example

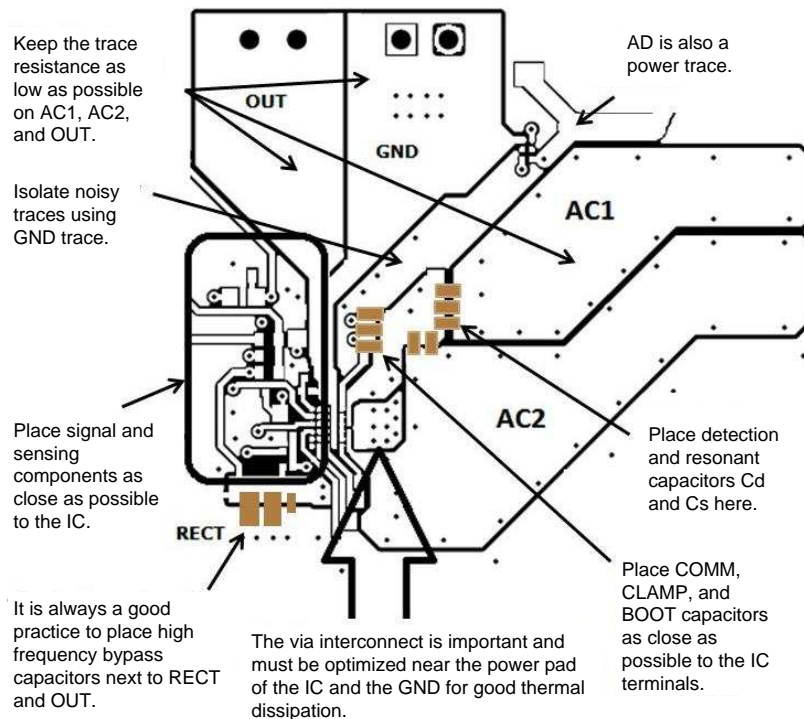

Figure 40. Layout Recommendation

12 Device and Documentation Support

12.1 Receiving Notification of Documentation Updates

To receive notification of documentation updates, navigate to the device product folder on ti.com. In the upper right corner, click on Alert me to register and receive a weekly digest of any product information that has changed. For change details, review the revision history included in any revised document.

12.2 Community Resources

The following links connect to TI community resources. Linked contents are provided "AS IS" by the respective contributors. They do not constitute TI specifications and do not necessarily reflect TI's views; see TI's [Terms of Use](#).

TI E2E™ Online Community *TI's Engineer-to-Engineer (E2E) Community*. Created to foster collaboration among engineers. At e2e.ti.com, you can ask questions, share knowledge, explore ideas and help solve problems with fellow engineers.

Design Support *TI's Design Support* Quickly find helpful E2E forums along with design support tools and contact information for technical support.

12.3 Trademarks

E2E is a trademark of Texas Instruments.
All other trademarks are the property of their respective owners.

12.4 Electrostatic Discharge Caution



These devices have limited built-in ESD protection. The leads should be shorted together or the device placed in conductive foam during storage or handling to prevent electrostatic damage to the MOS gates.

12.5 Glossary

[SLYZ022](#) — *TI Glossary*.

This glossary lists and explains terms, acronyms, and definitions.

13 Mechanical, Packaging, and Orderable Information

The following pages include mechanical, packaging, and orderable information. This information is the most current data available for the designated devices. This data is subject to change without notice and revision of this document. For browser-based versions of this data sheet, refer to the left-hand navigation.

PACKAGING INFORMATION

Orderable Device	Status (1)	Package Type	Package Drawing	Pins	Package Qty	Eco Plan (2)	Lead/Ball Finish (6)	MSL Peak Temp (3)	Op Temp (°C)	Device Marking (4/5)	Samples
BQ51025YFPR	NRND	DSBGA	YFP	42	3000	Green (RoHS & no Sb/Br)	SNAGCU	Level-1-260C-UNLIM	-40 to 125	BQ51025	
BQ51025YFPT	NRND	DSBGA	YFP	42	250	Green (RoHS & no Sb/Br)	SNAGCU	Level-1-260C-UNLIM	-40 to 125	BQ51025	

(1) The marketing status values are defined as follows:

ACTIVE: Product device recommended for new designs.

LIFEBUY: TI has announced that the device will be discontinued, and a lifetime-buy period is in effect.

NRND: Not recommended for new designs. Device is in production to support existing customers, but TI does not recommend using this part in a new design.

PREVIEW: Device has been announced but is not in production. Samples may or may not be available.

OBSOLETE: TI has discontinued the production of the device.

(2) **RoHS:** TI defines "RoHS" to mean semiconductor products that are compliant with the current EU RoHS requirements for all 10 RoHS substances, including the requirement that RoHS substance do not exceed 0.1% by weight in homogeneous materials. Where designed to be soldered at high temperatures, "RoHS" products are suitable for use in specified lead-free processes. TI may reference these types of products as "Pb-Free".

RoHS Exempt: TI defines "RoHS Exempt" to mean products that contain lead but are compliant with EU RoHS pursuant to a specific EU RoHS exemption.

Green: TI defines "Green" to mean the content of Chlorine (Cl) and Bromine (Br) based flame retardants meet JS709B low halogen requirements of <=1000ppm threshold. Antimony trioxide based flame retardants must also meet the <=1000ppm threshold requirement.

(3) MSL, Peak Temp. - The Moisture Sensitivity Level rating according to the JEDEC industry standard classifications, and peak solder temperature.

(4) There may be additional marking, which relates to the logo, the lot trace code information, or the environmental category on the device.

(5) Multiple Device Markings will be inside parentheses. Only one Device Marking contained in parentheses and separated by a "~" will appear on a device. If a line is indented then it is a continuation of the previous line and the two combined represent the entire Device Marking for that device.

(6) Lead/Ball Finish - Orderable Devices may have multiple material finish options. Finish options are separated by a vertical ruled line. Lead/Ball Finish values may wrap to two lines if the finish value exceeds the maximum column width.

Important Information and Disclaimer:The information provided on this page represents TI's knowledge and belief as of the date that it is provided. TI bases its knowledge and belief on information provided by third parties, and makes no representation or warranty as to the accuracy of such information. Efforts are underway to better integrate information from third parties. TI has taken and continues to take reasonable steps to provide representative and accurate information but may not have conducted destructive testing or chemical analysis on incoming materials and chemicals. TI and TI suppliers consider certain information to be proprietary, and thus CAS numbers and other limited information may not be available for release.

In no event shall TI's liability arising out of such information exceed the total purchase price of the TI part(s) at issue in this document sold by TI to Customer on an annual basis.

TAPE AND REEL INFORMATION



QUADRANT ASSIGNMENTS FOR PIN 1 ORIENTATION IN TAPE



*All dimensions are nominal

Device	Package Type	Package Drawing	Pins	SPQ	Reel Diameter (mm)	Reel Width W1 (mm)	A0 (mm)	B0 (mm)	K0 (mm)	P1 (mm)	W (mm)	Pin1 Quadrant
BQ51025YFPR	DSBGA	YFP	42	3000	330.0	12.4	2.99	3.71	0.81	8.0	12.0	Q1
BQ51025YFPT	DSBGA	YFP	42	250	330.0	12.4	2.99	3.71	0.81	8.0	12.0	Q1

TAPE AND REEL BOX DIMENSIONS

*All dimensions are nominal

Device	Package Type	Package Drawing	Pins	SPQ	Length (mm)	Width (mm)	Height (mm)
BQ51025YFPR	DSBGA	YFP	42	3000	367.0	367.0	35.0
BQ51025YFPT	DSBGA	YFP	42	250	367.0	367.0	35.0

EXAMPLE BOARD LAYOUT

YFP0042

DSBGA - 0.5 mm max height

DIE SIZE BALL GRID ARRAY

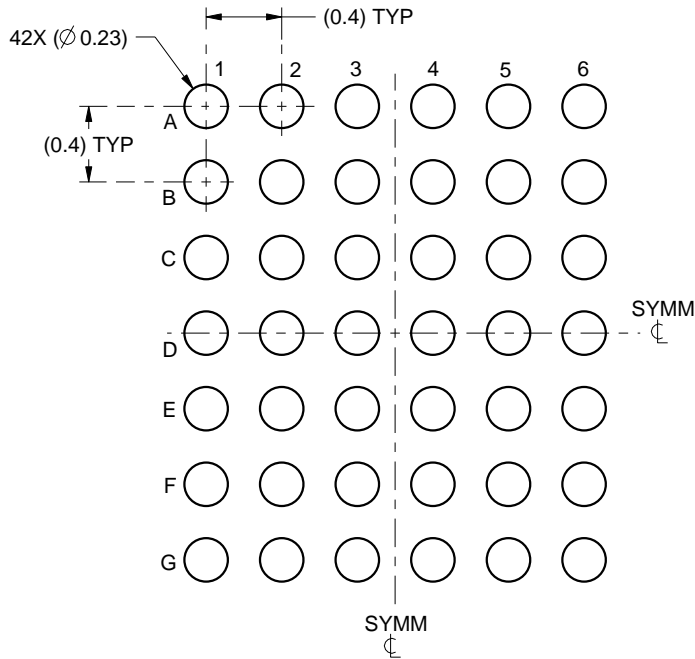

LAND PATTERN EXAMPLE
SCALE:25X

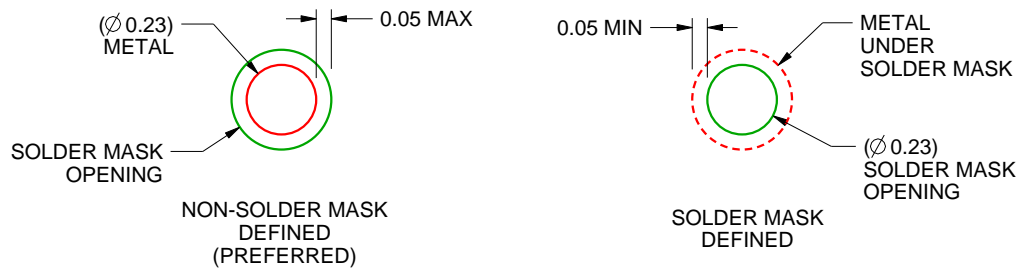

SOLDER MASK DETAILS
NOT TO SCALE

4221555/B 04/2015

NOTES: (continued)

- Final dimensions may vary due to manufacturing tolerance considerations and also routing constraints. For more information, see Texas Instruments literature number SNVA009 (www.ti.com/lit/snva009).

EXAMPLE STENCIL DESIGN

YFP0042

DSBGA - 0.5 mm max height

DIE SIZE BALL GRID ARRAY

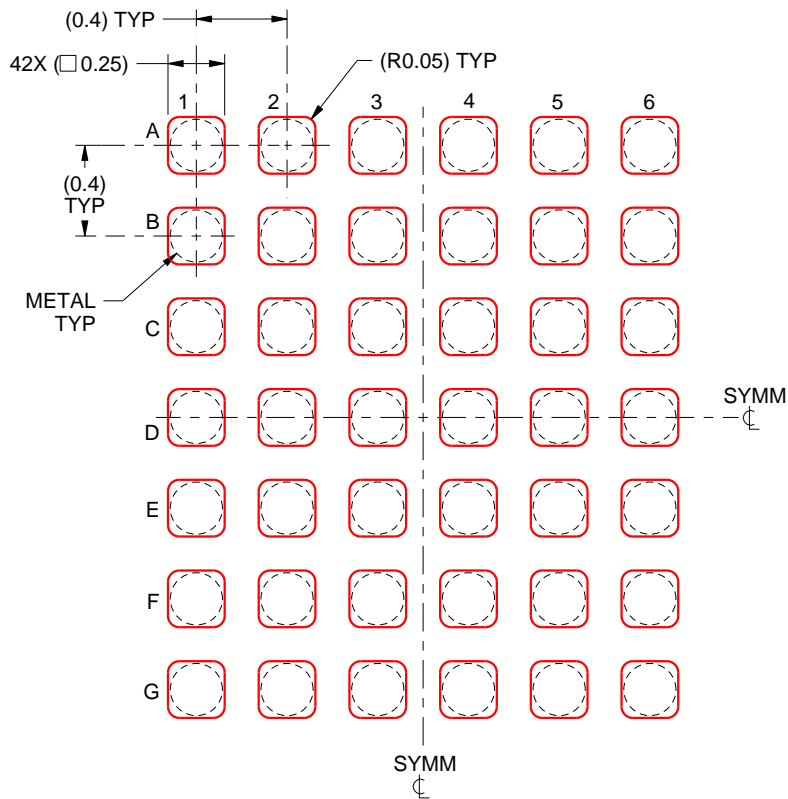

SOLDER PASTE EXAMPLE
BASED ON 0.1 mm THICK STENCIL
SCALE:30X

4221555/B 04/2015

NOTES: (continued)

4. Laser cutting apertures with trapezoidal walls and rounded corners may offer better paste release.

IMPORTANT NOTICE

Texas Instruments Incorporated (TI) reserves the right to make corrections, enhancements, improvements and other changes to its semiconductor products and services per JESD46, latest issue, and to discontinue any product or service per JESD48, latest issue. Buyers should obtain the latest relevant information before placing orders and should verify that such information is current and complete.

TI's published terms of sale for semiconductor products (<http://www.ti.com/sc/docs/stdterms.htm>) apply to the sale of packaged integrated circuit products that TI has qualified and released to market. Additional terms may apply to the use or sale of other types of TI products and services.

Reproduction of significant portions of TI information in TI data sheets is permissible only if reproduction is without alteration and is accompanied by all associated warranties, conditions, limitations, and notices. TI is not responsible or liable for such reproduced documentation. Information of third parties may be subject to additional restrictions. Resale of TI products or services with statements different from or beyond the parameters stated by TI for that product or service voids all express and any implied warranties for the associated TI product or service and is an unfair and deceptive business practice. TI is not responsible or liable for any such statements.

Buyers and others who are developing systems that incorporate TI products (collectively, "Designers") understand and agree that Designers remain responsible for using their independent analysis, evaluation and judgment in designing their applications and that Designers have full and exclusive responsibility to assure the safety of Designers' applications and compliance of their applications (and of all TI products used in or for Designers' applications) with all applicable regulations, laws and other applicable requirements. Designer represents that, with respect to their applications, Designer has all the necessary expertise to create and implement safeguards that (1) anticipate dangerous consequences of failures, (2) monitor failures and their consequences, and (3) lessen the likelihood of failures that might cause harm and take appropriate actions. Designer agrees that prior to using or distributing any applications that include TI products, Designer will thoroughly test such applications and the functionality of such TI products as used in such applications.

TI's provision of technical, application or other design advice, quality characterization, reliability data or other services or information, including, but not limited to, reference designs and materials relating to evaluation modules, (collectively, "TI Resources") are intended to assist designers who are developing applications that incorporate TI products; by downloading, accessing or using TI Resources in any way, Designer (individually or, if Designer is acting on behalf of a company, Designer's company) agrees to use any particular TI Resource solely for this purpose and subject to the terms of this Notice.

TI's provision of TI Resources does not expand or otherwise alter TI's applicable published warranties or warranty disclaimers for TI products, and no additional obligations or liabilities arise from TI providing such TI Resources. TI reserves the right to make corrections, enhancements, improvements and other changes to its TI Resources. TI has not conducted any testing other than that specifically described in the published documentation for a particular TI Resource.

Designer is authorized to use, copy and modify any individual TI Resource only in connection with the development of applications that include the TI product(s) identified in such TI Resource. NO OTHER LICENSE, EXPRESS OR IMPLIED, BY ESTOPPEL OR OTHERWISE TO ANY OTHER TI INTELLECTUAL PROPERTY RIGHT, AND NO LICENSE TO ANY TECHNOLOGY OR INTELLECTUAL PROPERTY RIGHT OF TI OR ANY THIRD PARTY IS GRANTED HEREIN, including but not limited to any patent right, copyright, mask work right, or other intellectual property right relating to any combination, machine, or process in which TI products or services are used. Information regarding or referencing third-party products or services does not constitute a license to use such products or services, or a warranty or endorsement thereof. Use of TI Resources may require a license from a third party under the patents or other intellectual property of the third party, or a license from TI under the patents or other intellectual property of TI.

TI RESOURCES ARE PROVIDED "AS IS" AND WITH ALL FAULTS. TI DISCLAIMS ALL OTHER WARRANTIES OR REPRESENTATIONS, EXPRESS OR IMPLIED, REGARDING RESOURCES OR USE THEREOF, INCLUDING BUT NOT LIMITED TO ACCURACY OR COMPLETENESS, TITLE, ANY EPIDEMIC FAILURE WARRANTY AND ANY IMPLIED WARRANTIES OF MERCHANTABILITY, FITNESS FOR A PARTICULAR PURPOSE, AND NON-INFRINGEMENT OF ANY THIRD PARTY INTELLECTUAL PROPERTY RIGHTS. TI SHALL NOT BE LIABLE FOR AND SHALL NOT DEFEND OR INDEMNIFY DESIGNER AGAINST ANY CLAIM, INCLUDING BUT NOT LIMITED TO ANY INFRINGEMENT CLAIM THAT RELATES TO OR IS BASED ON ANY COMBINATION OF PRODUCTS EVEN IF DESCRIBED IN TI RESOURCES OR OTHERWISE. IN NO EVENT SHALL TI BE LIABLE FOR ANY ACTUAL, DIRECT, SPECIAL, COLLATERAL, INDIRECT, PUNITIVE, INCIDENTAL, CONSEQUENTIAL OR EXEMPLARY DAMAGES IN CONNECTION WITH OR ARISING OUT OF TI RESOURCES OR USE THEREOF, AND REGARDLESS OF WHETHER TI HAS BEEN ADVISED OF THE POSSIBILITY OF SUCH DAMAGES.

Unless TI has explicitly designated an individual product as meeting the requirements of a particular industry standard (e.g., ISO/TS 16949 and ISO 26262), TI is not responsible for any failure to meet such industry standard requirements.

Where TI specifically promotes products as facilitating functional safety or as compliant with industry functional safety standards, such products are intended to help enable customers to design and create their own applications that meet applicable functional safety standards and requirements. Using products in an application does not by itself establish any safety features in the application. Designers must ensure compliance with safety-related requirements and standards applicable to their applications. Designer may not use any TI products in life-critical medical equipment unless authorized officers of the parties have executed a special contract specifically governing such use. Life-critical medical equipment is medical equipment where failure of such equipment would cause serious bodily injury or death (e.g., life support, pacemakers, defibrillators, heart pumps, neurostimulators, and implantables). Such equipment includes, without limitation, all medical devices identified by the U.S. Food and Drug Administration as Class III devices and equivalent classifications outside the U.S.

TI may expressly designate certain products as completing a particular qualification (e.g., Q100, Military Grade, or Enhanced Product). Designers agree that it has the necessary expertise to select the product with the appropriate qualification designation for their applications and that proper product selection is at Designers' own risk. Designers are solely responsible for compliance with all legal and regulatory requirements in connection with such selection.

Designer will fully indemnify TI and its representatives against any damages, costs, losses, and/or liabilities arising out of Designer's non-compliance with the terms and provisions of this Notice.

Looking for pricing, stock, or lifecycle information?

Click below to explore more details on WIN SOURCE:

 [View BQ51025YFPT on WIN SOURCE](#)

 [Texas Instruments](#) Information

Optimize Your Supply Chain with WIN SOURCE Solutions

-  Global Sourcing Solution
-  Obsolete Management
-  Cost Control Management
-  Shortage Management
-  Alternative Solution
-  Excess Inventory Management