



**THE DATASHEET OF  
8V19N470BFGI**



## Description

The 8V19N470 is a fully integrated FemtoClock® NG jitter attenuator and clock synthesizer designed as a high-performance clock solution for conditioning and frequency/phase management of wireless base station radio equipment boards.

The device is optimized to deliver excellent phase noise performance as required in GSM, WCDMA, LTE, LTE-A radio board implementations. A two-stage PLL architecture supports both jitter attenuation and frequency multiplication. The first stage PLL is the jitter attenuator and uses an external VCXO for best possible phase noise characteristics. The second stage PLL locks on the VCXO-PLL output signal and synthesizes the target frequency. This PLL has two VCO circuits at 2949.12MHz and 2400MHz–2500MHz, respectively, for enhanced frequency flexibility.

The device generates the output clock signals from the selected VCO by frequency division. Four independent integer frequency dividers are available. Delay circuits can be used for achieving alignment and controlled phase delay between clock signals. The two redundant inputs are monitored for activity. Four selectable clock switching modes are provided to handle clock input failure scenarios. Auto-lock, individually programmable output frequency dividers and phase adjustment capabilities are added for flexibility.

The device is configured through an SPI interface and reports PLL lock and signal loss status in internal registers, PLL lock status is also reported via two lock detect outputs. Internal status bit changes can also be reported via the nINT output. The device is ideal for driving converter circuits in wireless infrastructure, radar/imaging and instrumentation/medical applications. The device is a member of the high-performance clock family from IDT.

## Typical Applications

- Low phase noise clock generation, specifically for jitter-sensitive ADC and DAC circuits
- Wireless infrastructure applications: GSM, WCDMA, LTE, LTE-A
- Ethernet

## Features

- High-performance clock RF-PLL
- Optimized for low phase noise:  $\leq 150\text{dBc/Hz}$  (1MHz offset; 245.76MHz clock)
- Dual-PLL architecture
  - 1st-PLL stage with external VCXO for clock jitter attenuation
  - 2nd-PLL stage with internal FemtoClock NG PLL at selectable 2949.12MHz and 2400MHz – 2500MHz VCO
- Five output channels with a total of 11 outputs, organized in:
  - Two clock channels with two differential outputs
  - Two clock channels with three differential outputs
  - One VCXO-PLL channel with one selectable LVDS/ two LVCMOS outputs
- Each clock channel contains an integer output divider and a phase delay circuit with 512 steps of half of the VCO period
- Supported clock output frequencies include:
  - From VCO-0: 2949.12MHz, 1474.56MHz, 983.04MHz, 491.52MHz, 368.64MHz, 122.88MHz
  - From VCO-1: 2457.6MHz, 1228.8MHz, 614.4MHz, 307.2MHz, 153.6, 76.8MHz or 625MHz, 500MHz, 312.5MHz, 250MHz, 156.25MHz, and 125MHz
- Low-power LVPECL/LVDS outputs support configurable signal amplitude, DC and AC coupling and LVPECL, LVDS line terminations techniques
- Redundant input clock architecture
  - Two inputs
  - Individual input signal monitor
  - Digital holdover
  - Manual and automatic clock selection
  - Hitless switching
- Status monitoring and fault reporting
  - Input signal status
  - Lock status of each individual PLL (two status pins)
  - Hold-over and reference loss status
  - Mask-able status interrupt pin
- Voltage supply:
  - Device core supply voltage: 3.3V
  - Output supply voltage: 3.3V, 2.5V or 1.8V
  - Digital control I/O voltage: 1.8V (3.3V tolerant)
  - SPI control I/O voltage: 1.8V or 3.3V (selectable), 3.3V tolerant inputs when set to 1.8V
- Package: 81-FPBGA (8 × 8 × 1.35 mm, 0.8mm ball pitch)
- Temperature range: -40°C to +85°C

# Block Diagram

Figure 1. Block Diagram

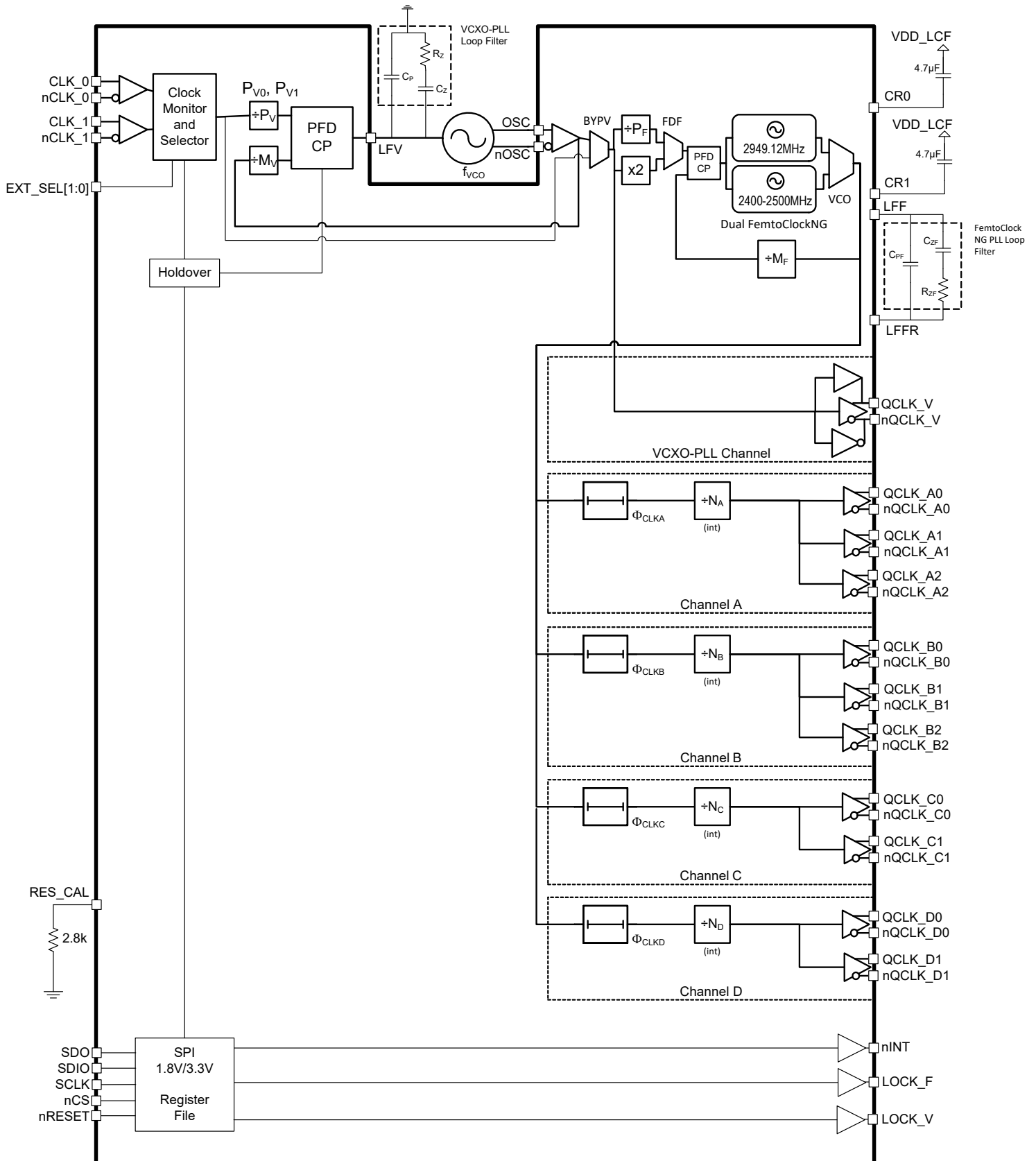

## Pin Assignments

Figure 2. Ball Map for 8 × 8 × 1.35mm, 81-CABGA Package with 0.8mm Ball Pitch – Bottom View

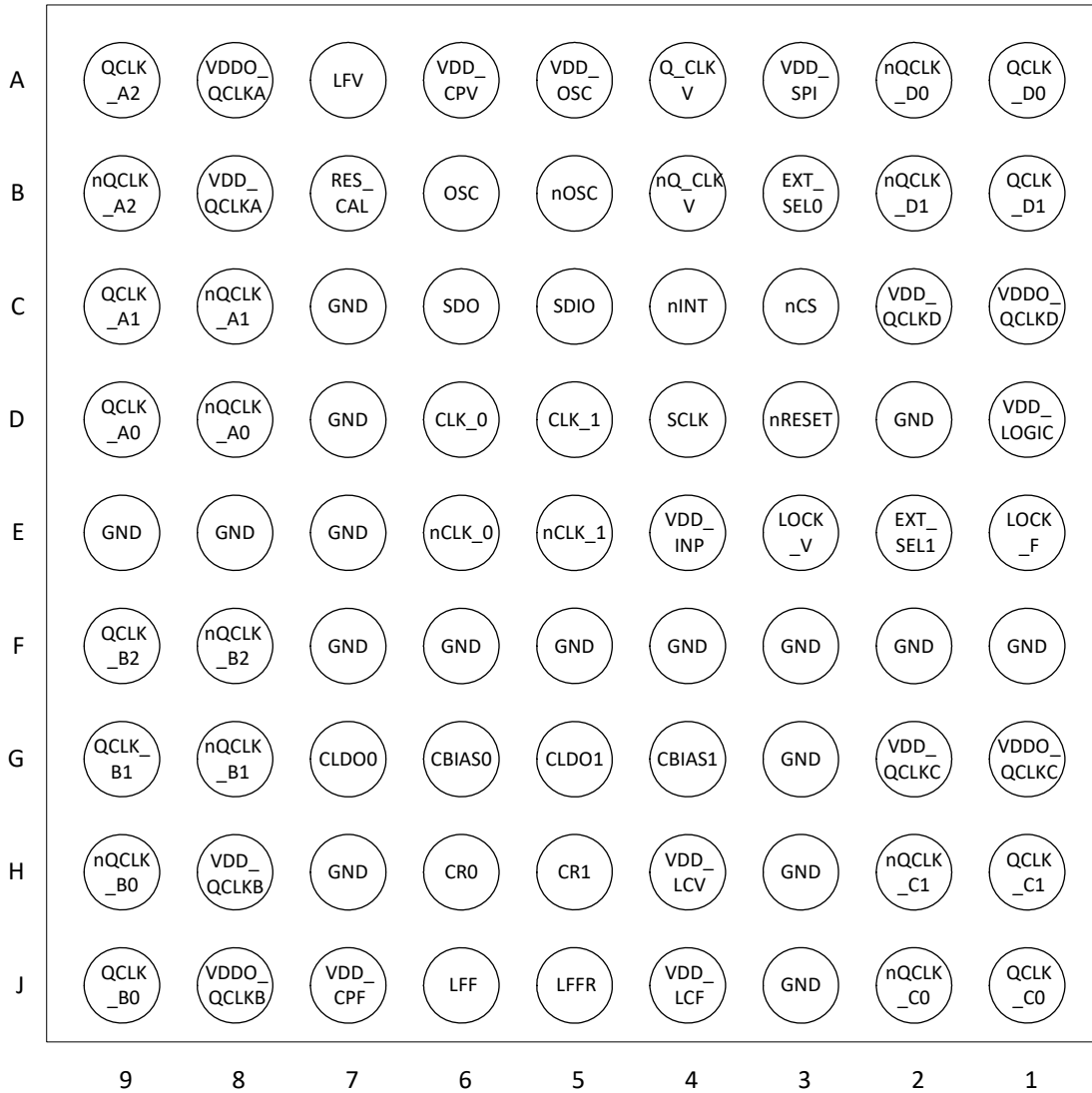

## Pin Descriptions

Table 1. Pin Descriptions<sup>[a]</sup>

Number	Name	Type <sup>[b]</sup>		Description
D6	CLK_0	Input	PD	Device clock 0 inverting and non-inverting differential clock input. Inverting input is biased to $V_{DD\_V} / 2$ by default when left floating. Compatible with LVPECL, LVDS and LVCMOS signals.
E6	nCLK_0		PD/PU	
D5	CLK_1	Input	PD	Device clock 1 inverting and non-inverting differential clock input. Inverting input is biased to $V_{DD\_V} / 2$ by default when left floating. Compatible with LVPECL, LVDS and LVCMOS signals.
E5	nCLK_1		PD/PU	
B3	EXT_SEL0	Input	PD	Clock reference select 0. 1.8V LVCMOS interface levels. 3.3V tolerant.
E2	EXT_SEL1	Input	PD	Clock reference select 1. 1.8V LVCMOS interface levels. 3.3V tolerant.
D9, D8	QCLK_A0, nQCLK_A0	Output		Differential clock output A0 (Channel A). Configurable LVPECL/LVDS style and amplitude. Output levels are determined by the VDDO_QCLKA supply voltage.
C9, C8	QCLK_A1, nQCLK_A1	Output		Differential clock output A1 (Channel A). Configurable LVPECL/LVDS style and amplitude. Output levels are determined by the VDDO_QCLKA supply voltage.
A9, B9	QCLK_A2, nQCLK_A2	Output		Differential clock output A2 (Channel A). Configurable LVPECL/LVDS style and amplitude. Output levels are determined by the VDDO_QCLKA supply voltage.
J9, H9	QCLK_B0, nQCLK_B0	Output		Differential clock output B0 (Channel B). Configurable LVPECL/LVDS style and amplitude. Output levels are determined by the VDDO_QCLKB supply voltage.
G9, G8	QCLK_B1, nQCLK_B1	Output		Differential clock output B1 (Channel B). Configurable LVPECL/LVDS style and amplitude. Output levels are determined by the VDDO_QCLKB supply voltage.
F9, F8	QCLK_B2, nQCLK_B2	Output		Differential clock output B2 (Channel B). Configurable LVPECL/LVDS style and amplitude. Output levels are determined by the VDDO_QCLKB supply voltage.
J1, J2	QCLK_C0, nQCLK_C0	Output		Differential clock output C0 (Channel C). Configurable LVPECL/LVDS style and amplitude. Output levels are determined by the VDDO_QCLKC supply voltage.
H1, H2	QCLK_C1, nQCLK_C1	Output		Differential clock output C1 (Channel C). Configurable LVPECL/LVDS style and amplitude. Output levels are determined by the VDDO_QCLKC supply voltage.
A1, A2	QCLK_D0, nQCLK_D0	Output		Differential clock output D0 (Channel D). Configurable LVPECL/LVDS style and amplitude. Output levels are determined by the VDDO_QCLKD supply voltage.
B1, B2	QCLK_D1, nQCLK_D1	Output		Differential clock output D1 (Channel D). Configurable LVPECL/LVDS style and amplitude. Output levels are determined by the VDDO_QCLKD supply voltage.
A4, B4	QCLK_V, nQCLK_V	Output		Differential VCXO-PLL clock outputs. Selectable LVPECL/LVDS/ (2x LVCMOS 1.8V) style.

Table 1. Pin Descriptions<sup>[a]</sup> (Cont.)

Number	Name	Type <sup>[b]</sup>		Description
C4	nINT	Output		Status output pin for signaling internal changed conditions. Selectable 1.8V/3.3V LVCMOS interface levels.
E3	LOCK_V	Output		PLL lock detect status output for the VCXO-PLL. Selectable 1.8V/3.3V LVCMOS interface levels.
E1	LOCK_F	Output		PLL lock detect status output for the FemtoClock NG PLL. Selectable 1.8V/3.3V LVCMOS interface levels.
C5	SDIO	Input/Output		Serial Control Port SPI Mode Clock Input/Output. Selectable 1.8V/3.3V LVCMOS interface levels for output. 1.8V interface levels (with hysteresis) when input.
C6	SDO	Output		Serial Control Port SPI Mode Output. Selectable 1.8V/3.3V LVCMOS interface levels.
D4	SCLK	Input	PD	Serial Control Port SPI Clock. Selectable 1.8V interface levels (with hysteresis). 3.3V tolerant.
C3	nCS	Input	PU	Serial Control Port SPI Chip Select Input. 1.8V interface levels (with hysteresis). 3.3V tolerant.
D3	nRESET	Input	PU	SPI interface reset. 1.8V interface levels. 3.3V tolerant.
H6	CR0	Analog		Internal VCO (0) regulator bypass capacitor. Use a 4.7 $\mu$ F capacitor between the CR0 and the VDD_LCF terminals.
H5	CR1	Analog		Internal VCO (1) regulator bypass capacitor. Use a 4.7 $\mu$ F capacitor between the CR1 and the VDD_LCF terminals.
A7	LFV	Output		VCXO-PLL charge pump output. Connect to the loop filter for the external VCXO.
B6, B5	OSC, nOSC	Input		VCXO non-inverting and inverting differential clock input. Compatible with LVPECL, LVDS and LVCMOS signals.
J6	LFF	Output		Loop filter/charge pump output for the FemtoClock NG PLL. Connect to the external loop filter.
J5	LFFR	Analog		Ground return path pin for the VCO loop filter.
B7	RES_CAL	Analog		Connect a 2.8 k $\Omega$ (1%) resistor to GND for output current calibration.
C7, D2, D7, E7, E8, E9, F1, F2, F3, F4, F5, F6, F7, G3, H3, H7, J3	GND	Power		Ground supply voltage (GND) and ground return path. Connect to board GND (0V).
G4	CBIAS1	Analog		Internal bias circuit for VCO-1. Connect a 4.7 $\mu$ F capacitor to GND.
G5	CLDO1	Analog		Internal LDO bypass for VCO-1. Connect a 10 $\mu$ F capacitor to GND.
G6	CBIAS0	Analog		Internal bias circuit for VCO-0. Connect a 4.7 $\mu$ F capacitor to GND.
G7	CLDO0	Analog		Internal LDO bypass for VCO-0. Connect a 10 $\mu$ F capacitor to GND.
A8	VDDO_QCLKA	Power		Positive supply voltage (3.3V, 2.5V or 1.8V) for the QCLK_A[2:0] outputs.

Table 1. Pin Descriptions<sup>[a]</sup> (Cont.)

Number	Name	Type <sup>[b]</sup>	Description
B8	VDD_QCLKA	Power	Positive supply voltage (3.3V) for channel A.
J8	VDDO_QCLKB	Power	Positive supply voltage (3.3V, 2.5V or 1.8V) for the QCLK_B[2:0] outputs.
H8	VDD_QCLKB	Power	Positive supply voltage (3.3V) for channel B.
G1	VDDO_QCLKC	Power	Positive supply voltage (3.3V, 2.5V or 1.8V) for the QCLK_C[1:0] outputs.
G2	VDD_QCLKC	Power	Positive supply voltage (3.3V) for channel C.
C1	VDDO_QCLKD	Power	Positive supply voltage (3.3V, 2.5V or 1.8V) for the QCLK_D[1:0] outputs.
C2	VDD_QCLKD	Power	Positive supply voltage (3.3V) for channel D.
D1	VDD_LOGIC	Power	Positive supply voltage (3.3V).
A3	VDD_SPI	Power	Positive supply voltage (3.3V) for the SPI interface.
E4	VDD_INP	Power	Positive supply voltage (3.3V) for the differential inputs (CLK[1:0]).
H4	VDD_LCV	Power	Positive supply voltage (3.3V) for the VCXO-PLL.
J4	VDD_LCF	Power	Positive supply voltage (3.3V) for the internal oscillator of the FemtoClock NG PLL. For essential information on power supply filtering, see <a href="#">Power Supply Filtering</a> .
A6	VDD_CPV	Power	Positive supply voltage (3.3V) for internal VCXO_PLL circuits.
J7	VDD_CPF	Power	Positive supply voltage (3.3V) for internal FemtoClock NG circuits.
A5	VDD_OSC	Power	Positive supply voltage (3.3V) for the VCXO input.

[a] For essential information on power supply filtering. See [Power Supply Filtering](#).

[b] PU (pull-up) and PD (pull-down) indicate internal input resistors. For values (see [Table 46](#)).

# Principles of Operation

## Overview

The device generates low-phase noise, synchronized clock output signals locked to an input reference frequency. The device contains two PLLs with configurable frequency dividers. The first PLL (VCXO-PLL, suffix V) uses an external VCXO as the oscillator and provides jitter attenuation. The external loop filter is used to set the VCXO-PLL bandwidth frequency in conjunction with internal parameters. The second, low-phase noise PLL (FemtoClock NG, suffix F) multiplies the VCXO-PLL frequency to one of its two selectable VCO frequencies of 2949.12MHz or 2457.6MHz. The FemtoClock NG PLL is completely internal and provides a central reference timing reference point for all output signals. From this point, fully synchronous dividers generate the output frequencies. The device has four output channels A – D, each with one integer output divider A – D. The clock outputs are configurable with support for LVPECL, LVDS formats and a variable output amplitude. In channels A – D, the clock phase can be adjusted in phase. For reduced power consumption, individual outputs, channels and unused circuit blocks support a power-down state. The register map, accessible through a selectable 3/4-wire SPI interface with read-back capability controls the main device settings and delivers device status information. For redundancy purpose, there are two selectable reference frequency inputs and a configurable switch logic with manual, auto-selection and holdover support.

## Phase-Locked Loop Operation

### Frequency Generation

**Table 2** displays the available frequency dividers for clock generation. The dividers must be set by the user to match input, VCXO and VCO frequency and to achieve frequency and phase lock on both PLLs. The frequency of the external VCXO is chosen by the user, the internal VCO frequency can be selected at frequencies of 2949.12MHz or 2457.6MHz. **Table 3 – Table 7** shows example divider configurations for typical wireless infrastructure applications.

Table 2. PLL Divider Values

Divider	Range	Operation	
		Jitter Attenuation (Dual PLL, BYPV = 0)	Frequency Synthesis (VCXO-PLL bypassed, BYPV = 1)
VCXO-PLL Pre-Divider $P_V$ <sup>[a]</sup>	$\div 1 \dots \div 32767$ : (15-bit)	Input clock frequency:  $f_{CLK} = P_V \times \frac{f_{VCXO}}{M_V}$	No external VCXO required
VCXO-PLL Feedback Divider $M_V$	$\div 1 \dots \div 32767$ : (15-bit)		
FemtoClock NG Pre-Divider $P_F$	$\div 1 \dots \div 63$ : (6-bit)	VCXO frequency:  $f_{VCXO} = \frac{P_F}{M_F} \times f_{VCO}$  $f_{VCO} = 2949.12\text{MHz or } 2457.6\text{MHz}$  $P_F$ : Set $P_F$ to 0.5 in above equation if the frequency doubler is engaged by setting $FDF = 1$	Input clock frequency:  $f_{CLK} = \frac{P_F}{M_F} \times f_{VCO}$  $f_{VCO} = 2949.12\text{MHz or } 2457.6\text{MHz}$  $P_F$ : Set $P_F$ to 0.5 in above equation if the frequency doubler is engaged by setting $FDF = 1$
FemtoClock NG Feedback Dividers $M_F$	$\div 8 \dots \div 511$ (9-bit)		
Output Divider $N_x$ , $x = A - D$	$\div 1 \dots \div 160$	Output frequency  $f_{OUT} = \frac{f_{VCO}}{N_X}$	

[a]  $P_V$  divider settings are in the *PV0 register* (for CLK\_0) and in the *PV1 register* (for CLK\_1). The device loads the PV divider from PV0 or PV1 according to the input selection. For details (see [Table 13](#)).

## VCXO-PLL

The prescaler  $P_V$  and the VCXO-PLLs feedback divider  $M_V$  require configuration to match the input frequency to the VCXO-frequency. With a  $M_V$  and  $P_V$  divider value range of 15 bits, the device supports a wide range of input and VCXO-frequencies. Two different input frequencies may be applied to the clock inputs CLK\_0 and CLK\_1. The single  $P_V$  divider has two correspond divider registers, PV0 and PV1. PV0 is loaded into the PV divider when the CLK\_0 input is selected and PV1 is loaded into the PV divider with the selection of the CLK\_1 input. For clock selection information, see [Table 13](#). Both CLK\_0 and CLK\_1 inputs may be monitored for input activity. For information, see [Monitoring](#).

In addition, the range of available input and feedback dividers allows to adjust the phase detector frequency independent of the used input and VCXO frequencies as shown in [Table 3](#) and [Table 4](#). The VCXO-PLL charge pump current is controllable via internal registers and can be set in 50 $\mu$ A steps from 50 $\mu$ A to 1.6mA. The VCXO-PLL may be bypassed (BYPV): when in bypass, the FemtoClock NG PLL locks to the pre-divided input frequency for frequency synthesis.

Table 3. Example Configurations for  $f_{VCXO} = 30.72\text{MHz}$

Input Frequency (MHz)	VCXO-PLL Divider Settings		$f_{PFD}$ (MHz)
	PV	MV	
122.88	4	1	30.72
	16	4	7.68
	64	16	1.92
	256	64	0.48
156.25	15625	3072	0.01

Table 4. Example Configurations for  $f_{VCXO} = 122.88\text{MHz}$

Input Frequency (MHz)	VCXO-PLL Divider Settings		$f_{PFD}$ (MHz)
	PV	MV	
122.88	4	4	30.72
	16	16	7.68
	64	64	1.92
	256	256	0.48

Table 5. Example Configurations for  $f_{VCXO} = 153.6\text{MHz}$

Input Frequency (MHz)	VCXO-PLL Divider Settings		$f_{PFD}$ (MHz)
	PV	MV	
122.88	4	5	30.72
	16	20	7.68
	64	80	1.92
	256	320	0.48
156.25	3125	3072	0.05

Table 6. Example Configurations for  $f_{VCXO} = 125\text{MHz}$

Input Frequency (MHz)	VCXO-PLL Divider Settings		$f_{PFD}$ (MHz)
	PV	MV	
25	1	5	25
	4	20	6.25
	16	80	1.5625
	64	320	0.390625
19.44	486	3125	0.04
125	1	1	125
	5	5	25
	25	25	5
	125	125	1
156.25	5	4	31.25
	50	40	3.125
	500	400	0.3125

Table 7. Example Configurations for  $f_{VCXO} = 156.25\text{MHz}$

Input Frequency (MHz)	VCXO- PLL Divider Settings		$f_{PFD}$ (MHz)
	PV	MV	
19.44	1944	15625	0.01
25	4	25	6.25
	40	250	0.625
	400	2500	0.0625
125	4	5	31.25
	40	50	3.125
	400	500	0.3125
156.25	1	1	156.25
	10	10	15.625
	100	100	1.5625

Table 8. VCXO-PLL Bypass Settings

BYPV	Operation
0	VCXO-PLL operation.
1	VCXO-PLL bypassed and disabled. The reference clock for the FemtoClock NG PLL is the selected input clock. Use EXT_SEL[1:0] for reference selection (00 or 01) or holdover (11). Device synthesizes an output frequency but will not attenuate input jitter. No external VCXO component and VCXO-PLL loop filter required. EXT_SEL[1:0] = 10 operation modes are not defined for VCXO-PLL bypass operation.

### FemtoClock NG PLL

The FemtoClock NG PLL is the second stage PLL and locks to the output signal of the VCXO-PLL (BYPV = 0). It requires configuration of the frequency doubler FDF or the pre-divider PF and the feedback divider MF to match the VCXO-PLL frequency to the selected VCO frequency of 2949.12MHz or 2457.6MHz. Best phase noise is typically achieved by engaging the internal frequency doubler (FDF = 1, ×2). If engaged, the signal from the first PLL stage is doubled in frequency, increasing the phase detector frequency of the FemtoClock NG PLL. Enabling the frequency doubler disables the frequency pre-divider PF. If the frequency doubler is not used (FDF = 0), the PF pre-divider has to be configured. Typically PF is set to ÷1 to keep the phase detector frequency as high as possible. Set PF to other divider values to achieve specific frequency ratios between first and second PLL stage. This PLL is internally configured to high-bandwidth.

Table 9. Frequency Doubler

FDF	Operation
0	Frequency doubler off. PF divides clock signal from VCXO-PLL or input (in bypass).
1	Frequency doubler on (×2). Signal from VCXO-PLL or input (in bypass) is doubled in frequency. PF divider has no effect.

Table 10. Example PLL Configurations

VCXO-Frequency (MHz)	FemtoClock NG Divider Settings for VCO					
	2949.12MHz			2457.6MHz		
	FDF	PF	MF	FDF	PF	MF
153.6	–	5	96	–	1	16
				x2	–	8
122.88	–	1	24	–	1	20
	x2	–	12	x2	–	10
30.72	–	1	96	–	1	80
	x2	–	48	x2	–	40

## Channel Frequency Divider

The device supports four independent output channels A – D. The channels A – D have one configurable integer frequency divider  $N_x$ ,  $x = A - D$  that divides the VCO frequency to the desired output frequency with very low phase noise. The integer divider values can be selected from the range of  $\div 1$  to  $\div 160$  as shown in [Table 11](#).

Table 11. Integer Frequency Divider Settings

Channel Divider $N_x^{[a]}$	Output Clock Frequency (MHz) for VCO (MHz)	
	2949.12	2457.6
$\div 1$	2949.12	2457.6
$\div 2$	1474.56	1228.8
$\div 3$	983.04	819.2
$\div 4$	737.28	614.4
$\div 5$	589.82	491.52
$\div 6$	491.52	409.6
$\div 8$	368.64	307.2
$\div 10$	294.912	245.76
$\div 12$	245.76	204.8
$\div 16$	184.32	153.6
$\div 18$	163.84	136.533
$\div 20$	147.456	122.88
$\div 24$	122.88	102.4
$\div 30$	98.304	81.92
$\div 32$	92.16	76.8
$\div 36$	81.92	68.266
$\div 40$	73.728	61.44
$\div 48$	61.44	51.2
$\div 50$	58.9824	49.152
$\div 60$	49.152	40.96
$\div 64$	46.08	38.4
$\div 72$	40.96	34.133
$\div 80$	36.864	30.72
$\div 96$	30.72	25.6
$\div 100$	29.4912	24.576
$\div 120$	24.576	20.48
$\div 128$	23.04	19.2
$\div 160$	18.432	15.36

[a]  $x = A - D$ .

## Redundant Inputs

The two inputs are compatible with LVDS, LVPECL signal formats and also support single-ended signals (LVCMOS, see [Applications Information](#) for applicable input interface circuits).

## Monitoring

The two clock inputs of the device are individually and permanently monitored for activity. Inactivity is defined by a static input signal. Input frequency changes are not monitored.

### Loss of Input Signal (LOS)

In operation, a clock input is declared invalid (LOS) with the corresponding  $ST\_CLK\_n$  and  $LS\_CLK\_n$  indicator bits set after a specified number of consecutive clock edges. If differential input signals are applied, the input will also detect an LOS condition in case of a zero differential input voltage. The device supports LOS detect circuits, one for each input. The signal detect circuits compare the signals at the  $CLK\_0$  and  $CLK\_1$  inputs to internally frequency-divided signals from the VCXO-PLL (see [Figure 3](#) for details). For each loss detect circuit, the loss-of-signal fault condition is declared upon three or more missing clock input edges. Both loss detect circuits operate independent of each other, allowing correct LOS signaling for two different input frequencies. LOS requires configuration of the  $N\_MON\_n[14:0]$  frequency dividers to individually match the input frequencies  $CLK\_n$  to the VCXO frequency:  $f_{VCXO} \div N\_MON\_n = f_{CLK\_n}$ . For instance, if one of the input frequencies is 15.36MHz and a 30.72MHz VCXO is used, set  $N\_MON\_n = \div 2$  (see [Table 31](#) for configuration details). Then, LOS is declared after three consecutive missing clock edges. LOS is signaled through the  $ST\_CLK\_n$  (momentary) and  $LS\_CLK\_n$  (sticky, resettable) status bits and can reported as an interrupt signal on the  $nINT$  output. The LOS circuit requires the jitter attenuation mode of device ( $BYPV = 0$ ). LOS does not detect frequency errors.

Figure 3. LOS Detect Circuit

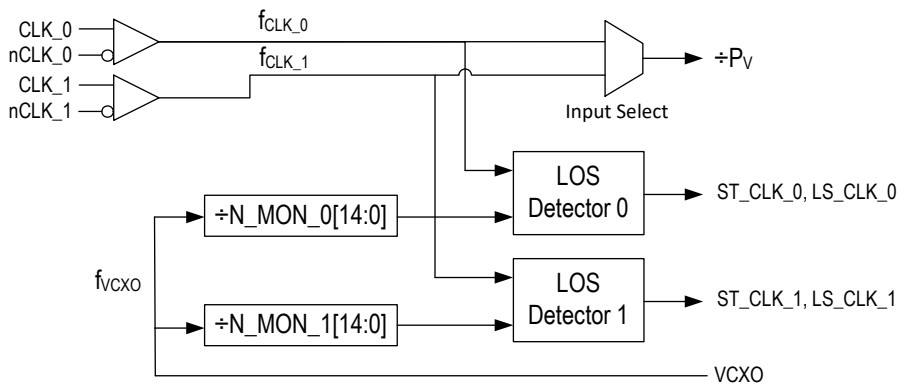

### Input Re-Validation

A clock input is declared valid and the corresponding  $ST\_CLK\_n$  bit is reset after the clock input signal returns for an user-configurable number of consecutive input periods. This re-validation of the selected input clock is controlled by the CNTV setting (verification pulse counter).

## Input Clock Selection

The device supports external, pin-controlled clock selection and internal, register controlled clock selection. The EXT\_SEL[1:0] pins control the input selection mode. In internal mode, automatic clock selection and manual register-controlled clock selection is available.

### Definitions for Input Clock Selection

**Manual input selection** The CLK\_n input is selected by the user by pin (external) or register control (internal).

**Automatic input selection** The CLK\_n input is selected by an internal state machine, based on internal priorities, as response to the clock input status.

### External Input Selection Controls

The EXT\_SEL[1:0] pins select CLK\_0 or CLK\_1 as the reference clock, enable switch control bits nMA[1:0], or set the device to holdover mode.

Table 12. Input Selection Mode

EXT_SEL[1:0] <sup>[a]</sup>	EN_nMA	nMA[1:0]	Reference Selection	
			Mode	Selected Input
00 (default)	X	X	External, Manual	CLK_0
01	X	X		CLK_1
10	0	x	External-Controlled Holdover – No Expiration Counter	—
	1	00	Internal-Controlled, Manual Holdover	by INT_SEL
	1	01	Automatic	by state machine
	1	10	Short-term Holdover	by INT_SEL
	1	11	Automatic with Holdover	by state machine
11	X	X	External-Controlled Holdover – No Expiration Counter (no expiration counter)	—

[a] Pin controlled input selection if EXT\_SEL[1] = 0; register controlled selection if EXT\_SEL[1] = 1.

## Internal Input Selection Controls

### Definitions for Automatic Input Selection

Primary clock: The CLK\_n input selected by the selection logic.

Secondary clock: The CLK\_n input not selected by the selection logic.

PLL reference clock: The CLK\_n input selected as the PLL reference signal by the selection logic. In automatic switching mode, the selection can be overwritten by a state machine.

Table 13. Internal Clock Selection Settings: Valid when EXT\_SEL[1:0] = 10 and EN\_nMA = 1

Mode		Name	Description	Flags				Application
nMA1	nMA0			ST_CLKn	nST_HOLD	ST_SEL	ST_REF	
0	0	Manual Holdover (default)	Input selection follows user-configuration of the INT_SEL register bit. Input selection is <i>never</i> changed by the internal state machine.	LOS status	1	selected input	0 <sup>[a]</sup>	selection control with holdover
			<u>LOS on the primary reference clock:</u> Active reference stays selected and the PLLs may stall. Device will not go into holdover.					
			<u>Manual change of the reference clock:</u> The device will go into holdover and the hold-off down-counter (CNTH) starts. The device initiates a clock switch <i>after</i> expiration of the hold-off counter. Duration of holdover is set by $CNTH \times CNTR / f_{VCXO}$ . Holdover is terminated even if the secondary clock input is bad (LOS). See <a href="#">Internal-Controlled, Manual Holdover</a>					
0	1	Automatic	Input selection follows LOS status. A failing input clock will cause an LOS event for that clock input. If the selected clock has an LOS event, the device will immediately initiate a clock fail-over switch, if the other clock is valid.	LOS status	1	selected input determined by state machine	actual LOS status of selected input determined by state machine	multiple inputs with qualified clock signals
			<u>LOS on the primary reference clock:</u> The device will switch to the secondary clock without holdover. Input selection is determined by a state machine and may differ from the user's clock selection. No valid clock scenario: If no valid input clocks exist, the device will not attempt to switch and will not enter the holdover state. The PLL is not locked. Re-validation of an input clock will result in the PLL to attempt to lock on that input clock. See <a href="#">Revertive Switching</a> . Both primary and secondary clock must have the same frequency for the PLL to resume lock upon transition to the secondary clock: set PV0 = PV1.					
			<u>Manual change of the reference clock:</u> The device will switch to the newly selected clock without holdover. If the newly selected clock is not valid, the PLL may stall.					

Table 13. Internal Clock Selection Settings: Valid when EXT\_SEL[1:0] = 10 and EN\_nMA = 1 (Cont.)

Mode		Name	Description	Flags				Application
nMA1	nMA0			ST_CLKn	nST_HOLD	ST_SEL	ST_REF	
1	0	Short-term Holdover	Input selection follows user-configuration of INT_SEL register bit. Selection is never changed by the internal state machine.	LOS status	0	selected input	0	use if a single reference is occasionally interrupted
			<u>LOS on the primary reference clock:</u> A failing reference clock will cause an LOS event. If the selected reference fails, the device will enter holdover immediately. Re-validation of the selected input clock is controlled by the CNTV setting. A successful re-validation will result in the PLL to re-lock on that input clock.					
			<u>Manual change of the reference clock:</u> The device will switch to the newly selected clock without holdover. If the newly selected clock is not valid, the PLL may stall.					
1	1	Automatic with Holdover	Input selection follows LOS status. A failing input clock will cause an LOS event for that clock input. If the <i>selected</i> clock has an LOS event, the device will go into holdover and switches input clocks after the hold-off counter expires.	LOS status	0 for holdover duration	selected input determined by state machine	actual LOS status of selected input	multiple inputs
			<u>LOS on the primary reference clock or manual change of the reference clock:</u> the device will go into holdover and the hold-off down-counter (CNTH) starts. The device initiates a clock fail-over switch to a valid secondary clock input <i>after</i> expiration of the hold-off counter. Duration of holdover is set by $CNTH \times CNTR / f_{VCO}$ . The holdover is terminated prior hold-off count-down if the primary clock revalidates or is terminated by a manual change of the reference clock. See <a href="#">Automatic with Holdover</a> and <a href="#">Revertive Switching</a> . Both primary and secondary clock must have the same frequency for the PLL to resume lock upon transition to the secondary clock: set PV0 = PV1. No valid clock scenario: The device remains in holdover if the secondary input clock is invalid.					

- [a] For the duration of an invalid input signal (LOS).
- [b] For the duration of holdover.
- [c] Delayed by holdover period.

## Holdover

In holdover state, the output frequency and phase is derived from an internal, digital value based on previous frequency and phase information. Holdover characteristics are defined in [Table 54](#).

### **External-Controlled Holdover – No Expiration Counter**

Applying the configuration  $EXT\_SEL[1:0] = 11$  or ( $EXT\_SEL[1:0] = 10$  and  $EN\_nMA = 0$ ) sets the device in holdover. No clock input is selected. Leaving holdover requires a change from either of the two configurations above.

### **Internal-Controlled, Manual Holdover**

Input switch control is manual by setting the configuration to  $EXT\_SEL[1:0] = 10$ ,  $EN\_nMA = 1$ , and  $nM/A[1:0] = 00$ . The  $INT\_SEL$  bit determines the selected reference clock input. If the selection is changed by the user, the device will enter holdover until the  $CNTH[7:0]$  counter expires. Then, the new reference is selected (input switch). Application for this mode is external selection control.

- $ST\_REF$ : status of selected reference clock
- $ST\_CLK\_n$  will both reflect the status of the corresponding input
- $ST\_SEL$ : the new selection after holdover
- $nST\_HOLD = 0$  for the duration of holdover

### **Automatic with Holdover**

Configuration:  $EXT\_SEL[1:0] = 10$ ,  $EN\_nMA = 1$ , and  $nM/A[1:0] = 11$ .

If an LOS event is detected on the active reference clock:

- Holdover begins immediately
- Corresponding  $ST\_REF$  and  $LS\_REF$  go low immediately
- Hold-off countdown begins immediately

During this time, both input clocks continue to be monitored and their respective  $ST\_CLK$ ,  $LS\_CLK$  flags are active. LOS events will be indicated on  $ST\_CLK$ ,  $LS\_CLK$  when they occur.

If the active reference clock resumes and is validated during the hold-off countdown:

- its  $ST\_CLK$  status flag will return high and the  $LS\_CLK$  is available to be cleared by an SPI write of 1 to that register bit.
- No transitions will occur of the active REF clock;  $ST\_SEL$  does not change
- Revertive bit has no effect during this time (whether 0 or 1)

When the hold-off countdown reaches zero:

- If the active reference has resumed and has been validated during the countdown, it will maintain being the active reference clock
  - $ST\_SEL$  does not change
  - $ST\_REF$  returns to 1
  - $LS\_REF$  can be cleared by an SPI write of 1 to that register
  - Holdover turns off and the VCXO-PLL attempts to lock to the active reference clock
- If the active reference has not resumed, but the other clock input  $CLK\_n$  is validated, then
  - $ST\_SEL$  changes to the new active reference
  - $ST\_REF$  returns to 1
  - $LS\_REF$  can be cleared by an SPI write of 1 to that register
  - Holdover turns off

If there is no validated CLK:

- ST\_SEL does not change
- ST\_REF remains low
- LS\_REF cannot be cleared by an SPI write of 1 to that register
- Holdover remains active

Revertive capability returns if REVS = 1.

#### Hold-off Counter

A configurable down-counter applicable to the *Automatic with Holdover* and *Manual with Holdover* selection modes. The purpose of this counter is a deferred, user-configurable input switch. The counter expires when a zero-transition occurs; this triggers a new reference clock selection. The counter is clocked by the frequency-divided VCXO-PLL signal. The CNTR setting determines the hold-off counter frequency divider and the CNTH setting the start value of the hold-off counter. For instance, set CNTR to a value of  $\pm 131072$  to achieve 937.5Hz (or a period of 1.066ms at  $f_{VCXO} = 122.88\text{MHz}$ ): the 8-bit CNTH counter is clocked by 937.5Hz and the user-configurable hold-off period range is 0ms

(CNTR = 0x00) to 272ms (CNTR = 0xFF). After the counter expires, it reloads automatically from the CNTH SPI register. After the LOS status bit (LS\_CLK\_n) for the corresponding input CLK\_n has been cleared by the user, the input is enabled for generating a new LOS event.

The CNTR counter is only clocked if the device is configured in the clock selection modes *Automatic with Holdover* and the selected reference clock experiences an LOS event or in the *Manual with Holdover* mode with manual switching. Otherwise, the counter is automatically disabled (not clocked).

#### Revertive Switching

Revertive switching: is only applicable to the two automatic switch modes shown in [Table 13](#). Revertive switching enabled: Re-validation of the primary clock will cause a new input selection to that clock (revertive switch). An input switch is only done if the re-validated input is the primary clock.

Revertive switching disabled: Re-validation of a primary clock has no impact on the clock selection. Default setting is revertive switching disabled.

#### VCXO-PLL Lock Detect (LOLV)

The VCXO-PLL lock detect circuit uses the signal phase difference at the phase detector as loss-of-lock criteria. Loss-of-lock is reported if the actual phase difference is larger than a configurable phase detector window set by the LOCK\_TH[14:0] configuration bits. A Loss-of-lock state is reported through the nST\_LOLV and nLS\_LOLV status bits as shown in [Table 17](#). The VCXO-PLL lock detect function requires to set FVCV = 0.

#### FemtoClock NG Loss-of-Lock (LOLF)

FemtoClock NG-PLL Loss-of-lock is signaled through the nST\_LOLF (momentary) and nLS\_LOLF (sticky, resettable) status bits and can be reported as hardware signal on the LOCK\_V output as well as an interrupt signal on the nINT output.

## Differential Outputs

Table 14. Output Features

Output	Style	Amplitude <sup>[a]</sup>	Disable	Power Down	Termination
QCLK_y	LVPECL	350mV – 850mV 4 steps	Yes	Yes	50Ω to V <sub>TT</sub> <sup>[b]</sup>
	LVDS				100Ω diff.
QCLK_V	LVPECL	350mV – 850mV 4 steps	Yes	Yes	50Ω to V <sub>TT</sub>
	LVDS				100Ω diff.
	LVC MOS <sup>[c]</sup>	1.8V	Yes	Yes	–

[a] Amplitudes are measured single-endedly.

[b] For V<sub>TT</sub> (termination voltage) values (see [Table 60](#)).

[c] LVC MOS style: nQCLK\_V and QCLK\_V are complementary.

Table 15. Individual Clock Output Settings

PD <sup>[a]</sup>	Output Power	STYLE	Termination	Enable	State	A[1:0]	Amplitude (mV) <sup>[b]</sup>
1	Off	X	100Ω differential or no termination	X	Off	X	X
0	On	0	100Ω differential (LVDS)	0	Disable <sup>[c]</sup>	XX	X
				1	Enable	00	350
						01	500
						10	700
		11	850				
		1	50Ω to V <sub>TT</sub> <sup>[d]</sup> (LVPECL)	0	Disable	XX	X
				1	Enable	00	350
						01	500
10	700						
11	850						

[a] Power-down modes are available for the individual channels A – D and the outputs QCLK\_y (A0 to D1).

[b] Output amplitudes of 700mV and 850mV require a 3.3V output supply (V<sub>DDO\_V</sub>). 350mV and 500mV output amplitudes support V<sub>DDO\_V</sub> = 2.5V and 1.8V.

[c] Differential output is disabled in static low/high state.

[d] For V<sub>TT</sub> (termination voltage) values (see [Table 60](#)).

## Output Phase-Delay

Output phase delay is supported in each channel. The selected VCO frequency sets the delay unit to  $1/2 \times f_{VCO}$ .

Table 16. Delay Circuit Settings

Delay Circuit	Unit	Steps	Range
Clock Phase $\Phi_{CLK_x}$	$\frac{1}{2 \times f_{VCO}}$ $f_{VCO} = 2949.12\text{MHz}: 169\text{ps}$ $f_{VCO} = 2457.6\text{MHz}: 203\text{ps}$	512	0 – 86.664ns 0 – 103.963ns

## Status Conditions and Interrupts

The device has an interrupt output to signal changes in status conditions. Settings for status conditions may be accessed in the Status registers. The device has several conditions that can indicate faults and status changes in the operation of the device. These are shown in [Table 17](#) and can be monitored directly in the status registers. Status bits (named: *ST\_status\_condition*) are read-only and reflect the momentary device status at the time of read-access. Several status bits are also copied into latched bit positions (named: *LS\_status\_condition*). The latched version is controlled by the corresponding fault and status conditions and remains set (“sticky”) until reset by the user by writing “1” to the status register bit. The reset of the status condition only has an effect if the corresponding fault condition is removed, otherwise, the status bit will set again. Setting a status bit on several latched registers can be programmed to generate an interrupt signal (nINT) via settings in the Interrupt Enable bits (named: *IE\_condition*). A setting of “0” in any of these bits will mask the corresponding latched status bits from affecting the interrupt status pin. Setting all IE bits to 0 has the effect of disabling interrupts from the device.

Table 17. Status Bit Functions

Status Bit		Function			Interrupt Enable Bit
Momentary	Latched	Description	Status if Bit is:		
			1	0	
ST_CLK_0	LS_CLK_0	CLK 0 input status	Active	LOS	IE_CLK_0
ST_CLK_1	LS_CLK_1	CLK 1 input status	Active	LOS	IE_CLK_1
nST_LOLV	nLS_LOLV	VCXO-PLL Loss-of-lock	Locked	Loss-of-lock	IE_LOLV
nST_LOLF	nLS_LOLF	FemtoClock NG PLL Loss-of-lock	Locked	Loss-of-lock	IE_LOLF
nST_HOLD	nLS_HOLD	Holdover	Not in holdover	Device in holdover	IE_HOLD
ST_VCOF	—	FemtoClock NG VCO calibration	Not completed	Completed	—
ST_SEL	—	Clock input selection	0 = CLK_0 1 = CLK_1		—
ST_REF	LS_REF	PLL reference status	Valid reference <sup>[a]</sup>	Reference lost	IE_REF

[a] Manual and short-term holdover mode: 0 indicates if the selected reference is lost, 1 if not lost.

Automatic mode: will transition to 0 while the input clock is lost and during input selection.

Will transition to 1 once a new reference is selected.

Automatic with holdover mode: 0 indicates the reference is lost and still in holdover.

Interrupts are cleared by resetting the appropriate bit(s) in the latched register after the underlying fault condition has been resolved. When all valid interrupt sources have been cleared in this manner, this will release the nINT output until the next unmasked fault.

Table 18. Fault Indicator Outputs

Status Bit (PLL)		Status Reported on LOCK_V <sup>[a]</sup> Output <sup>[b]</sup>	Status Reported on LOCK_F <sup>[a]</sup> Output <sup>[b]</sup>
nLS_LOLV (VCXO-PLL)	nLS_LOLF (FemtoClock NG)		
Locked	Locked	1	1
Locked	Not locked	1	0
Not locked	Locked	0	1
Not locked	Not locked	0	0

[a] Hardware interrupts on nINT require IE\_LOLV = 1, IE\_LOLF = 1 (interrupt enable).

[b] SELSV[2:1] bits control the logic level (1.8V/ 3.3V) of LOCK\_V, LOCK\_F and nINT outputs.

## Device Startup, Reset and Synchronization

At startup, an internal POR (power-on reset) resets the device and sets all register bits to their default value. The device forces the VCXO control voltage at the LfV pin to half of the power supply voltage to center the VCXO-frequency. In the default configuration the QCLK\_y outputs are disabled at startup.

Recommended configuration sequence (in order):

- (Optional) set the value of the CPOL register bit to define the SPI read mode supported by the SPI controller. Set the LSBIT\_1ST, SDO\_ACT, ACS\_ON and the corresponding mirrored bits in register 0x00 as appropriate for SPI read access to the device.
- Configure all PLL and output divider and delay circuits as well as other device configurations, such as the charge pump currents. Set the TRANSFER bit (register 0x0F, bit D0) for PLL registers wider than then 8 bit (see double buffered registers).
- Set the initialization bit INIT\_CLK. This will initiate all divider and delay circuits and synchronize them to each other. The INIT\_CLK bit will self-clear.
- Set both the RELOCK bit and PB\_CAL bit. This step should not be combined with the previous step (setting INIT\_CLK) in a multi SPI-byte register access. Both bits will self-clear.
- Clear the FVCV bit to release the VCXO control voltage and VCXO-PLL will attempt to lock to the input clock signal starting from its center frequency.
- Clear the status flags.
- (Optional and recommended) Optimize the internal precision bias current calibration process:
  - Read the contents of the STAT\_PB[5:1] register (precision bias current in register 0x4E, ignore STAT\_PB[0])
  - With a single-byte write access to register 0x63, apply the following bit pattern to OVERRIDE\_CURR[5:0] and OVERRIDE\_CAL:
    - OVERRIDE\_CURR[5:1] (bit field location D[6:2] of register 0x63 = STAT\_PB[5:1] as read from above step
    - OVERRIDE\_CURR[0] (bit field location D[1] of register 0x63) = 0
    - OVERRIDE\_CAL (bit field location D[0] of register 0x63) = 1
- Enable the outputs by accessing the output-enable registers in a separate SPI write access.

## Changing Frequency Dividers and Phase Delay Values

Following procedure has to be applied for a change of a clock divider and phase delay value  $N_{A-D}$ , and  $\Phi_{CLKA-D}$ :

- (Optional) set the value of the CPOL register to define the SPI read mode, so that SPI settings can be validated by subsequent SPI read accesses.
- (Optional) disable the outputs whose frequency divider or delay value is changed.
- Configure the  $N_{A-D}$  dividers and the delay circuits  $\Phi_{CLKA-D}$  to the desired new values.
- Set the initialization bit INIT\_CLK. This will initiate all divider and delay circuits and synchronize them to each other. The INIT\_CLK bit will self-clear. During this initialization step, all QCLK\_y outputs are reset to the logic low state.
- Set the RELOCK bit. This step should not be combined with the setting INIT\_CLK in a multi SPI-byte register access. Bit will self-clear.
- (Optional) enable the outputs whose frequency divider was changed.

## SPI Interface

The device has a selectable 3/4-wire serial control port capable of responding as a slave in an SPI configuration to allow read and write access to any of the internal registers for device programming or read back. The SPI interface consists of the SCLK (clock), SDIO (serial data input and output in 3-wire mode, input in 4-wire mode), SDO (output in 4-wire mode), nCS (chip select) and nRESET (SPI reset) pins. A data transfer contains 16 bit (direction + 15 bit address) and any integer multiple of 8 bits (input or output data) and is always initiated by the SPI master on the bus. Internal register data is organized in SPI bytes of 8 bit each. This device supports most-significant bit (MSBit) and least-significant (LSBit) first transfer bit positions, single byte and multi-byte data streaming modes with address auto-increment and auto-decrement. For SPI logic diagrams, see [Figure 4](#) to [Figure 5](#). For the SPI timing diagram, see [Figure 8](#).

**Chip Select.** If the nCS pin is at logic high, the SDIO/SDO data output pin is in high-impedance state and the SPI interface of the device is disabled.

**3/4-Wire Mode.** In 3-wire mode, the SDIO pin acts as bidirectional input/output and the SDO pin is in high-impedance state. In 4-wire mode, the SDIO pin is the SPI input and the SDO pin is the SPI output. The SPI interface mode is defined by the SDO\_ACT bit in the SPI device configuration register.

**Active Clock Edge.** In a write operation, data on SDIO will be clocked in on the rising edge of SCLK. In a read operation, data on SDIO/SDO will be clocked out on the falling or rising edge of SCLK depending on the CPOL setting (CPOL = 0: output data changes on the falling edge, CPOL = 1: output data changes on the rising edge).

**Reset.** By asserting the nRESET pin, the SPI engine is reset and all internal device registers reset to their default values. The SRESET bit in the device SPI configuration register resets the registers 0x02 to 0x63 to their default values. The registers 0x00 and 0x01 are not reset by asserting SRESET.

**Logic levels.** The SPI pins SDIO and SDO have selectable 1.8V/3.3V logic levels. The SELSV0 register bit controls the logic level. SELSV0 = 0: 1.8V logic, and SELSV0 = 1: 3.3V logic.

**Least Significant Bit Position.** The device supports LSBit (least significant bit first) and MSBit (most significant bit first) transfers between master and slave. If MSBit first is set, data is transferred in this order: transfer direction bit first, then the register address bits A14 to A0, then the data bits of the first data byte D7 to D0. If LSBit first is set, the order is: address bits A0 to A14 first, then the transfer direction bit, then the data bits of the first data byte D0 to D7.

**Starting a Data Transfer** requires the nCS pin to set and hold at logic low level during the entire transfer. Setting nCS = 0 will enable the SPI interface with the SDIO pin in data input mode. The master must initiate the first 16-bit transfer containing the transfer direction bit and the SPI register address to access.

**Transfer Direction Bit:** Defines if the master reads data from the device or writes data to the device. R/nW (1 = Read, 0 = Write). If MSB-first is set, the transfer bit is presented by the master as the first bit in the transfer. If LSB-first is set, the transfer bit is the 16th bit presented by the master. MSB-first is the default upon power-up: the initial data transfer must be in MSB-first order.

**Address:** The device supports a 15 bit address A[14:0] pointing to an internal register in the address space 0 to 0x7FFF. This device implements registers at the addresses 0x00-0x63.

**Read operation from an internal register:** a read operation starts with a 16 bit transfer from the master to the slave: the SDIO signal is clocked on the *rising* edge of SCLK. The transfer direction bit R/nW must be to 1 to indicate a read transfer, the other 15 bits is the address A[14:0] to read from. After the first 16 bits are clocked into the SDIO pin, the SDIO I/O changes to output if 4-wire mode is set by SDO\_ACT = 0 (in 3-wire mode set by SDO\_ACT = 1, the pin SDO is the output). The register content addressed by A[14:0] are the presented at the SPI output at the next 8 SCLK *falling* (CPOL = 1) or next eight SCLK *rising* (CPOL = 1) clock cycles and transfer these to the master. Transfers must be completed with de-asserting nCS after any multiple eight of SCLK cycles. If nCS is de-asserted at any other number of SCLKs, the SPI behavior is undefined. Read operation transfers multiple bytes in streaming mode with the 15 bit register address auto-increment or decrement. Single byte transfers are supported in streaming mode by de-asserting nCS after the first payload byte.

**Write operation to a device register:** During a write transfer, an SPI master transfers one or more bytes of data into the internal registers of the device. A write transfer starts by asserting the nCS to pin low logic level. The transfer direction bit R/nW must be set to 0 to indicate a write transfer, the other 15 bits are the address A[14:0] to write to. Bits D[7:0] contain 8 bits of transfer data, which is written into the register specified by A[14:0] at the end of each 8-bit write transfer. Multiple, subsequent register transfers from the master to the slave are supported in streaming mode by holding nCS asserted at logic low level during write transfers. Transfers must be completed with de-asserting nCS after any multiple of eight SCLK cycles. If nCS is de-asserted at any other number of SCLKs, the SPI behavior is undefined. The 15 bit register address will auto-increment or decrement (streaming mode). Single byte transfers are supported in streaming mode by de-asserting nCS after the first payload byte.

**Register Streaming Mode.** Streaming mode is the transfer of multiple data bytes back to back. The address A[14:0] specifies the register location of the first byte to transfer, for the following transfer, the address is automatically incremented or decremented. nCS must stay at logic low level and SDIO/SDO will present multiple registers, e.g. (A), (A -1), (A -2), etc. with each eight SCLK cycles. During SPI Read operations, the user may continue to hold nCS low and provide further bytes. The ASC\_ON register defines if registers auto-increment (A), (A +1), (A +2), etc. or auto-decrement (A), (A -1), (A -2), etc.

**Address wrap-around:** Applicable to streaming mode: The address will wrap-around the address range of 0x00 – 0x63. The SPI engine auto-increments to address 0x00 after 0x63 and auto-decrements to address 0x63 after 0x00.

**End of transfer:** After nCS is de-asserted to logic 1, the SPI bus is available to transfers to other slaves on the SPI bus. The READ diagrams (Figure 5, Figure 6, and Figure 7) and WRITE diagram (Figure 4) display the transfer of a single byte of data from and into registers.

**Mirrored Register Bits.** The register bits D7 – D4 in the device SPI configuration register (0x00) are mirrored with the bits D3 – D0 in the same register for a LSBit/MSBit First independent access. Setting a mirrored bit to the “1” state requires to set both bit and its <mirrored\_bit> to 1.

**Double Buffered Registers.** PLL divider registers that are wider than 8 bit are double buffered for synchronous access. Synchronous configuration of these registers requires to write the multiple-byte setting into the SPI registers first and then transfer the content into the device registers by asserting the TRANSFER bit. The configuration only takes effect after the TRANSFER bit is asserted. Configuration data can be read-back from SPI and device registers as specified by the RB\_MODE bit.

**Internal Debug Registers.** Registers in the address range 0x4F, 0x5C – 0x5D and 0x64 to 0xFF should not be used. Do not write into any registers in the 0x4F, 0x5C – 0x5D and 0x64 to 0xFF address range.

**Default SPI Modes:** After power-up and reset by the nRESET pin, the SPI interface is in 3-wire mode with SDO in high-impedance, MSB-first mode, streaming mode on with address auto-decrement. In read transfer mode, data is output on SDIO on the falling SCLK edge.

Figure 4. Logic Diagram: Single Byte WRITE Data into Device Registers in SPI 3 or 4-wire Mode for LSB and MSB-First

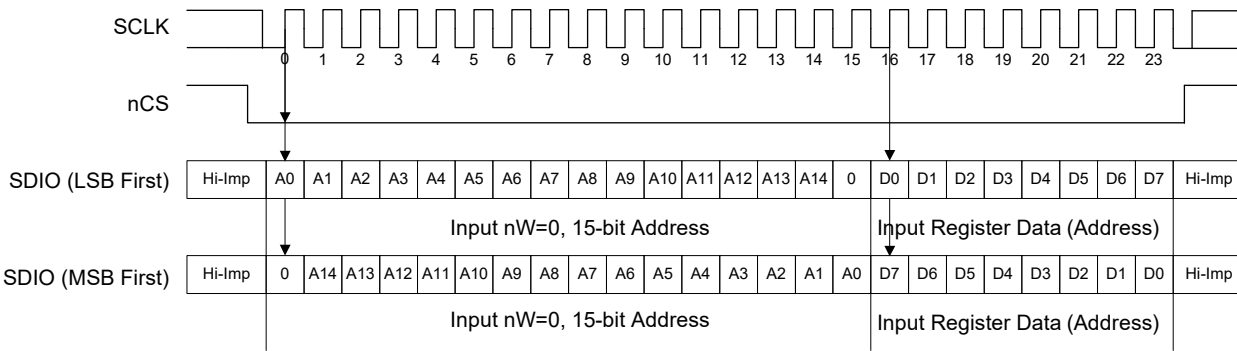

Figure 5. Logic Diagram: Single Byte READ Data from the Device Registers in SPI 3-wire Mode for LSB and MSB-First and CPOL = 0, 1

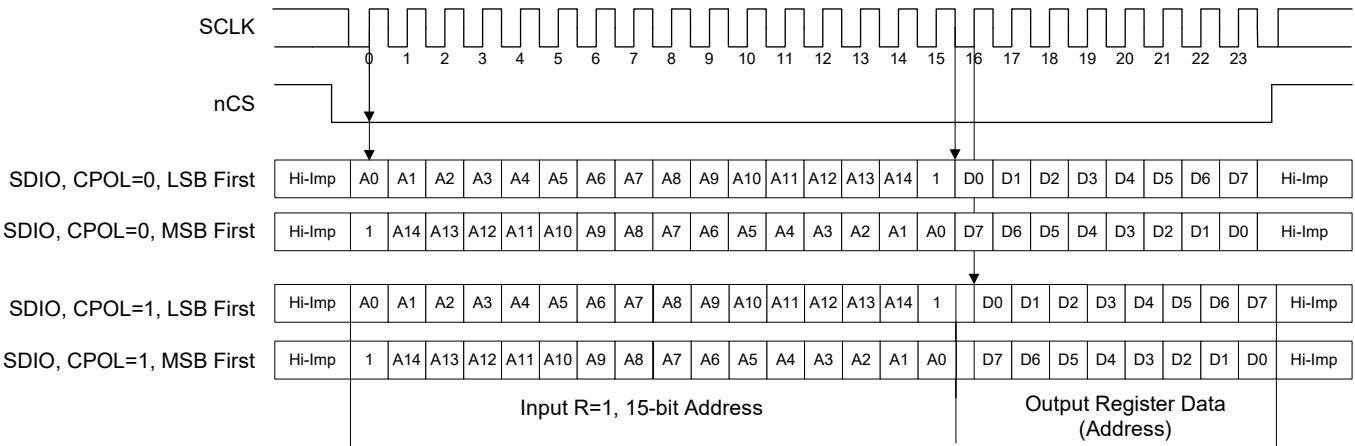

Figure 6. Logic Diagram: Single Byte READ Data from the Device Registers in SPI 4-wire Mode for LSB-First and CPOL = 0, 1

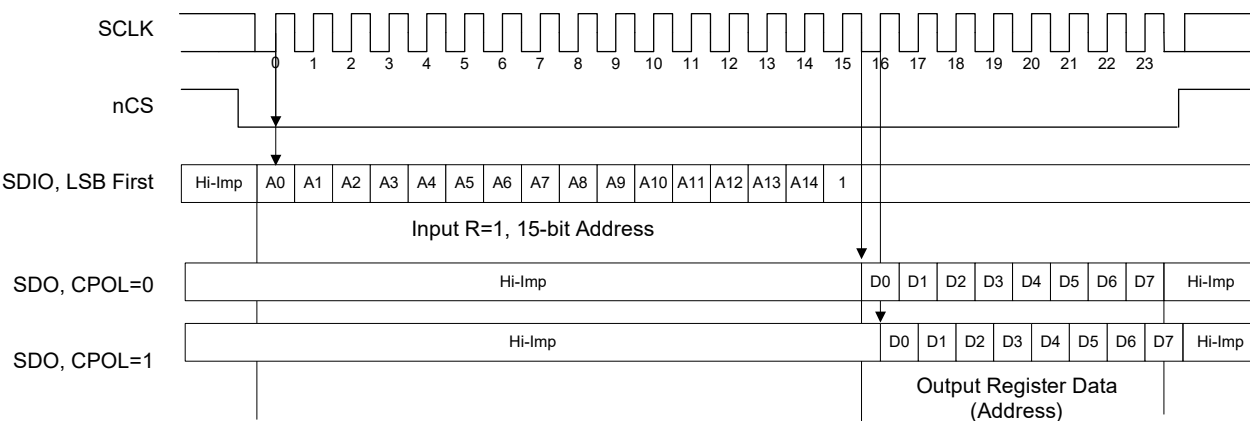

Figure 7. Logic Diagram: Single Byte READ Data from the Device Registers in SPI 4-wire Mode for MSB-First and CPOL = 0, 1

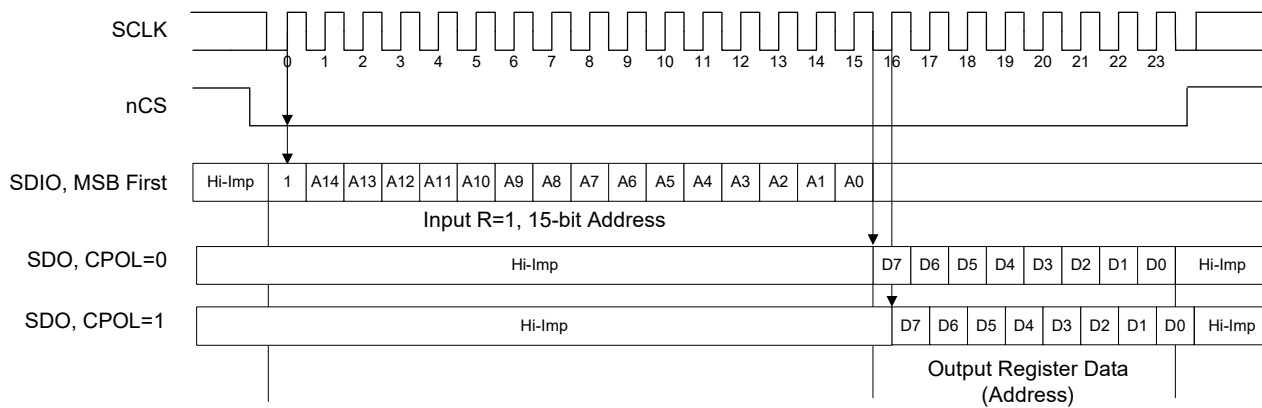
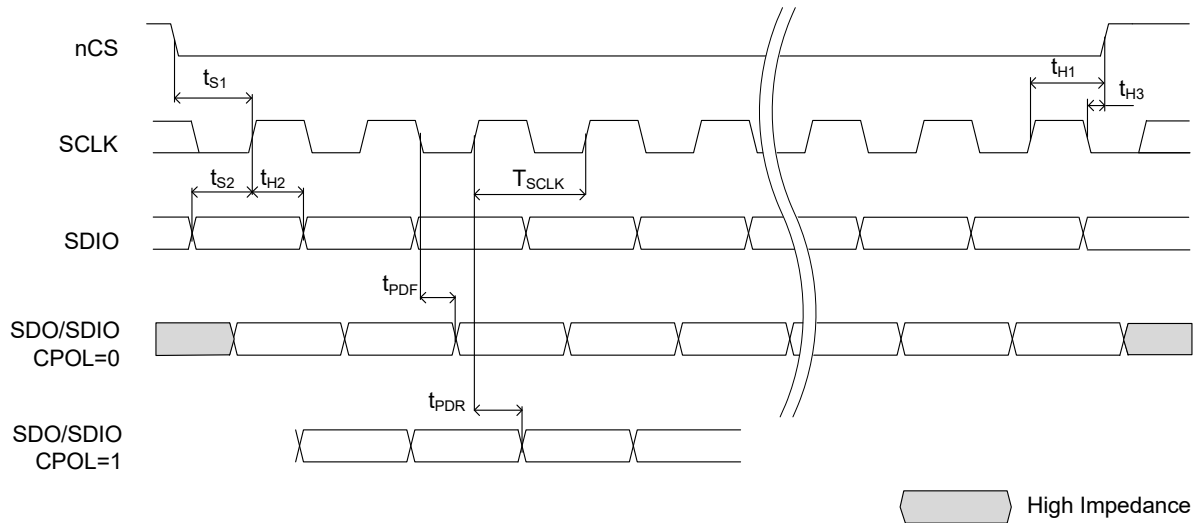

Table 19. SPI Read / Write Cycle Timing Parameters

Symbol	Parameter	Test Condition	Minimum	Maximum	Unit
$f_{SCLK}$	SCLK Frequency			20	MHz
$T_{SCLK}$	SCLK Clock Period		50		ns
$t_{S1}$	Setup Time, nCS (falling) to SCLK (rising)		10		ns
$t_{S2}$	Setup Time, SDIO (input) to SCLK (rising)		8		ns
$t_{H1}$	Hold Time, SCLK (rising) to nCS (rising)		30		ns
$t_{H2}$	Hold Time, SCLK (rising) to SDIO (input)		8		ns
$t_{H3}$	Hold Time, SCLK (falling) to nCS (rising)		8		ns
$t_{PDF}$	Propagation Delay, SCLK (falling) to SDIO (output in 3-wire mode) or SDO (in 4-wire mode)	CPOL = 0		10	ns
$t_{PDR}$	Propagation Delay, SCLK (rising) to SDIO (output in 3-wire mode) or SDO (in 4-wire mode)	CPOL = 1		10	ns
$t_{WRES}$	nRESET Pulse Width		100		ns

Figure 8. SPI Timing Diagram



Configurable Logic Levels for LVCMOS Control Outputs

Table 20. SDO, SDIO Logic Levels

SELSV0	SDO, SDIO <sup>[a]</sup> Output Logic Levels
0 (default)	1.8V
1	3.3V

[a] SDIO as input: set SELSV0 = 0 for 1.8V SPI logic levels and SELSV0 = 1 for 3.3V SPI logic levels. The SDIO input threshold is ~0.9V regardless of SELSV0.

Table 21. nINT, LOCK\_V Logic Levels

SELSV1	nINT, LOCK_V Output Logic Levels
0 (default)	1.8V
1	3.3V

Table 22. LOCK\_F Logic Levels

SELSV2	LOCK_F Output Logic Levels
0 (default)	1.8V
1	3.3V

## Register Descriptions

### List of Registers

Table 23. Configuration Registers

Register Address	Register Description
0x00–0x02	Device Configuration: SPI
0x03	Device Type
0x04–0x05	Device ID
0x06	Device Version
0x07–0x0B	Reserved
0x0C–0x0D	Vendor ID
0x0E	Reserved
0x0F	Device Configuration: SPI
0x10–0x11	PLL Frequency Divider: PV0
0x12–0x13	PLL Frequency Divider: PV1
0x14–0x15	PLL Frequency Divider: MV
0x16–0x17	LOCK_TH
0x18	PLL Control: BYPV, VCO_SEL
0x19	PLL Frequency Divider: PF, FDF
0x1A–0x1B	PLL Frequency Divider: MF[8:0]
0x1C–0x1E	PLL Control
0x1F	I/O Voltage Select
0x20–0x23	Input Selection
0x24–0x26	Channel A
0x27	Reserved
0x28–0x2A	Output States QCLK_A0-A2
0x2B	Reserved
0x2C–0x2E	Channel B
0x2F	Reserved
0x30–0x32	Output States QCLK_B0-B2
0x33	Reserved
0x34–0x36	Channel C
0x37	Reserved
0x38–0x39	Output States QCLK_C0-C1
0x3A–0x3B	Reserved
0x3C–0x3E	Channel D

Table 23. Configuration Registers (Cont.)

Register Address	Register Description
0x3F	Reserved
0x40–0x41	Output States QCLK_D0-D1
0x42–0x43	Reserved
0x44–0x45	N_MON_0
0x46–0x47	N_MON_1
0x48–0x4A	Reserved
0x4B	Output States QCLK_V
0x4C	Interrupt Enable
0x4D	Reserved
0x4E	Debug Control Status
0x4F	Reserved
0x50	Status (Latched)
0x51	Status (Momentary)
0x52	Reserved
0x53	Status (Momentary)
0x54	Reserved
0x55–0x57	General Control
0x58	Channel Enable A–D and QCLK_V
0x59–0x5B	Reserved
0x5C–0x5E	Reserved
0x5F–0x60	Reserved
0x61–0x62	Reserved
0x63	Precision Bias Control
0x64–0xFF	Reserved

## Register Descriptions

This section contains all addressable registers, sorted by function, followed for a detailed description of each bit field for each register. Several functional blocks with multiple instances in this device have individual registers controlling their settings, but since the registers have an identical format and bit meaning, they are described only once, with an additional table to indicate their addresses and default values. All writable register fields will come up with the default values as indicated in the factory *Default* column.

Fixed read-only bits will have defaults as indicated in their specific register descriptions. Read-only status bits will reflect valid status of the conditions they are designed to monitor once the internal power-up reset has been released. Unused registers and bit positions are Reserved. Reserved bit fields may be used for internal debug test and debug functions.

## Device Configuration Registers

Table 24. Device Configuration Register Bit Field Locations

Bit Field Location								
Register Address	D7	D6	D5	D4	D3	D2	D1	D0
0x00	SRESET	LSBIT_1ST	ACS_ON	SDO_ACT	<SDO_ACT>	<ACS_ON>	<LSBIT_1ST>	<SRESET>
0x01	STR_OFF	Reserved	RB_MODE	Reserved	Reserved	Reserved	Reserved	Reserved
0x02	Reserved	Reserved	Reserved	Reserved	Reserved	Reserved	PWR_DN[1:0]	
0x03	DEV_TYPE[7:0]							
0x04	DEV_ID[7:0]							
0x05	DEV_ID[15:8]							
0x06	DEV_VER[7:0]							
0x0C	VENDOR_ID[7:0]							
0x0D	VENDOR_ID[15:8]							
0x0F	Reserved	Reserved	Reserved	Reserved	Reserved	Reserved	Reserved	TRANSFER
0x1F	Reserved	Reserved	Reserved	Reserved	Reserved	SELSV2	SELSV1	SELSV0

Table 25. Device Configuration Register Descriptions

Register Description			
Bit Field Name	Field Type	Default (Binary)	Description
SRESET <SRESET>	R/W  Auto-Clear	0  Value: not reset	Soft Reset: 0 = Normal operation. 1 = Register reset. The device loads the default values into the registers 0x02–0xFF. The content of the register addresses 0x00 and 0x01 and the SPI engine are not reset. SRESET bit D7 is mirrored with <SRESET> in bit position D0. Register reset requires to set both SRESET and <SRESET> bits.
LSBIT_1ST <LSBIT_1ST>	R/W	0  Value: MSB first	Least Significant Bit Position: Defines the bit transmitted first in SPI transfers between slave and master. 0 = The most significant bit (D7) first 1 = The least significant bit (D0) first LSBIT_1ST bit D6 is mirrored with <LSBIT_1ST> in bit position D1. Changing LSBIT_1ST to most significant bit requires to set both LSBIT_1ST and <LSBIT_1ST> bits.
ASC_ON <ASC_ON>	R/W	0  Value: off, addresses auto-decrement	Address Ascend on: 0 = Address ascend is off (addresses auto-decrement in streaming SPI mode) 1 = Address ascend is on (addresses auto-increment in streaming SPI mode) The ASC_ON bit specifies whether addresses are incremented or decremented in streaming SPI transfers. ASC_ON bit D5 is mirrored with <ASC_ON> in bit position D2. Changing ASC_ON to “ON” requires to set both ASC_ON and <ASC_ON> bits.
SDO_ACT <SDO_ACT>	R/W	0  Value: SPI-3-wire mode	SPI 3/4 Wire Mode: Selects the unidirectional or bidirectional data transfer mode for the SDIO pin. 0 = SPI 3-wire mode: – SDIO is the SPI bidirectional data I/O pin – SDO pin is not used and is in high-impedance 1 = SPI 4-wire mode – SDIO is the SPI data input pin – SDO is the SPI data output pin SDO_ACT bit D4 is mirrored with <SDO_ACTIVE> in bit position D3. Changing SDO_ACT to SPI 4-wire mode requires to set both SDO_ACT and <SDO_ACT> bits.

Table 25. Device Configuration Register Descriptions (Cont.)

Register Description			
Bit Field Name	Field Type	Default (Binary)	Description
STR_OFF	R/W	0  Value: SPI streaming mode enabled	<p>SPI Streaming Mode (not implemented):</p> <p>0 = SPI streaming mode enabled 1 = SPI single byte transfer mode</p> <p>In SPI streaming mode, the device transfers SPI data back to back while auto-decrementing (if ASC_ON = 0) or auto-incrementing (if ASC_ON = 1) the SPI register address after each byte access. The device continues to read or write SPI data as long as nCS remains asserted and the SPI streaming mode remains enabled.</p> <p>In SPI streaming mode, single byte data transfers are supported by setting nCS to logic high state after the byte has been transferred.</p> <p>In SPI single byte transfer mode, one byte of SPI data is transferred regardless of nCS being de-asserted after the transfer. If this bit is set and nCS remains asserted, the SPI state machine resets after the data byte is transferred as if nCS was de-asserted and awaits the next transfer.</p> <p>The device does not implement STR_OFF = 1. For implemented SPI single byte transfers (see <a href="#">Figure 4</a> – <a href="#">Figure 7</a>).</p>
RB_MODE	R/W	0  Value: read from device registers	<p>Read Back Mode:</p> <p>The device implements double buffered registers for frequency divider registers wider than 8 bit (registers for PV0, PV1, MV, LOCK_TH, MF, N_MON_0, and N_MON1). There are SPI registers and device registers. This bit specifies whether a read operation accesses the SPI or the device registers.</p> <p>0 = Read operation from PV0, PV1, MF, LOCK_TH, N_MON_0, NMON_1 and MV device registers 1 = Read operation from PV0, PV1, MF, LOCK_TH, N_MON_0, NMON_1 and MV SPI registers</p> <p>To transmit data from the SPI to device registers, see the TRANSFER bit.</p>
PWR_DN[1:0]	R/W	00  Value:	<p>Power-down Mode:</p> <p>00, 01, 10, 10 = Normal operation. Setting this PWR_DN[1:0] has no effect.</p>
DEV_TYP[7:0]	R only	0000 0110  Value: RF-PLL	<p>Device (Chip) Type:</p> <p>Reads 0x06 (RF-PLL) after power-up and reset.</p>
DEV_ID[15:0]	R only	0x04: 0100 0010 0x05: 0000 0000  Value: 0x0042	<p>Device ID:</p> <p>Device is composed of registers 0x05 (high byte) and register 0x04 (low byte). Reads 0x0042 after power-up and reset.</p>
DEV_VER[7:0]	R only	0x04  Value: 4	<p>Device Version:</p> <p>0x04. Reads 0x04 (Silicon revision D) after power-up and reset.</p>

Table 25. Device Configuration Register Descriptions (Cont.)

Register Description			
Bit Field Name	Field Type	Default (Binary)	Description
VENDOR_ID	R only	0x0C: 0010 0110 0x0D: 0000 0100  Value: 0x0426	Vendor ID: 0x0426 (Integrated Device Technology, IDT). Reads 0x0426 (IDT) after power-up and reset.
TRANSFER	R/W  Auto-clear	0  Value: no transfer	SPI Transfer:  The device implements double buffered registers for frequency divider registers wider than 8-bit (registers for PV0, PV1, MF, LOCK_TH, N_MON_0, NMON_1 and MV). There are SPI registers and device registers. Setting this bit to 1 will copy the content of the PV0, PV1, MF, LOCK_TH, N_MON_0, NMON_1 and MV SPI registers synchronously and simultaneously into the device registers where the settings will affect the device operation. For reading from SPI vs. device registers, see the RB_MODE setting.  0 = No transfer 1 = The SPI registers are transferred into the device registers.
SELSV2	R/W	0  Value: 1.8V	Selects the voltage level of the LOCK_F output: SELSV2: 0 = LOCK_F interface pin is 1.8V (default) 1 = LOCK_F interface pin is 3.3V
SELSV1	R/W	1  Value: 3.3V	Selects the voltage level of the nINT and LOCK_V outputs: SELSV1: 0 = nINT and LOCK_V interface pins are 1.8V 1 = nINT and LOCK_V interface pins are 3.3V (default)
SELSV0	R/W	0  Value: 1.8V	Selects the voltage level of the SPI interface (SDIO and SDO pins): SELSV0: 0 = SPI interface pins (SDIO and SDO) are 1.8V (default) 1 = SPI interface pins (SDIO and SDO) are 3.3V

## PLL Frequency Divider Registers

Table 26. PLL Frequency Divider Register Bit Field Locations

Bit Field Location								
Register Address	D7	D6	D5	D4	D3	D2	D1	D0
0x10					PV0[7:0]			
0x11	Reserved					PV0[14:8]		
0x12					PV1[7:0]			
0x13	Reserved					PV1[14:8]		
0x14					MV[7:0]			
0x15	Reserved					MV[14:8]		
0x16					LOCK_TH[7:0]			
0x17	Reserved					LOCK_TH[14:8]		
0x19	FDF	Reserved					PF[5:0]	
0x1A					MF[7:0]			
0x1B	Reserved	Reserved	Reserved	Reserved	Reserved	Reserved	Reserved	MF8

Table 27. PLL Frequency Divider Register Descriptions

Register Description			
Bit Field Name	Field Type	Default (Binary)	Description
PV0[14:0]	R/W	000 0000 0000 1000  Value: ÷8	VCXO-PLL Input Frequency Pre-Divider Register 0: The value of the frequency divider $P_V$ (binary coding) if CLK_0 is the selected input clock. Range: ÷1 to ÷32767. PV0[14:0] is located in double-buffered registers (see the RB_MODE and TRANSFER bit settings). PV0 is loaded into the PV divider of the VCXO-PLL when CLK_0 is the selected clock input.

Table 27. PLL Frequency Divider Register Descriptions (Cont.)

Register Description			
Bit Field Name	Field Type	Default (Binary)	Description
PV1[14:0]	R/W	000 0000 0000 1000  Value: ÷8	VCXO-PLL Input Frequency Pre-Divider Register 1: The value of the frequency divider $P_V$ (binary coding) if CLK_1 is the selected input clock. Range: ÷1 to ÷32767. PV1[14:0] is located in double-buffered registers (see the RB_MODE and TRANSFER bit settings). PV1 is loaded into the PV divider of the VCXO-PLL when CLK_1 is the selected clock input.
MV[14:0]	R/W	000 0000 0000 1000  Value: ÷8	VCXO-PLL Feedback-Divider: The value of the frequency divider MV (binary coding). Range: ÷1 to ÷32767. MV[14:0] is located in double-buffered registers (see the RB_MODE and TRANSFER bit settings).
LOCK_TH[14:0]	R/W	000 0000 0000 0011  Value: 3	PLL Lock Detect Phase Window Threshold: The device reports VCXO-PLL lock when the phase difference between the internal signals $f_{REF}$ and $f_{VCXO\_REF}$ are lower than or equal to the phase difference set by LOCK_TH[14:0] for more than $1000 f_{VCXO\_DIV}$ clock cycles. Requires $M_V \geq 4$ . Set LOCK_TH[14:0] < $M_V$ . ( $f_{REF} = f_{CLK} \div P_V$ is the internal output of the PV divider, $f_{VCXO\_DIV} = f_{VCXO} \div M_V$ is the internal output of the MV divider.) LOCK_TH[14:0] is located in double-buffered registers (see the RB_MODE and TRANSFER bit settings).
PF[5:0]	R/W	00 0001  Value: ÷1	FemtoClock NG Pre-Divider: The value of the frequency divider (binary coding). Range: ÷1 to ÷63. 00 0000: PF is bypassed
FDF	R/W	1  Value: $f_{VCXO} \times 2$	The input frequency of the FemtoClock NG PLL (2nd stage) is: 0 = the output signal of the BYPV multiplexer, divided by the PF divider. 1 = the output signal of the BYPV multiplexer, doubled in frequency. Use this setting to improve phase nose. The PF divider has no effect if FDF = 1.
MF[8:0]	R/W	0 0011 0000  Value: ÷48	FemtoClock NG Pre-Divider: The value of the frequency divider (binary coding). Range: ÷8 to ÷511. MF is located in double-buffered registers (see the RB_MODE and TRANSFER bits settings).

## PLL Control Registers

Table 28. PLL Control Register Bit Field Locations

Bit Field Location								
Register Address	D7	D6	D5	D4	D3	D2	D1	D0
0x18	Reserved	Reserved	Reserved	Reserved	Reserved	Reserved	BYPV	VCO_SEL
0x1C	POLV	FVCV	Reserved			CPV[4:0]		
0x1D	Reserved	Reserved	OSVEN			OFFSET[4:0]		
0x1E	Reserved	Reserved	Reserved			CPF[4:0]		

Table 29. PLL Control Register Descriptions

Register Description			
Bit Field Name	Field Type	Default (Binary)	Description
BYPV	R/W	0 VCXO-PLL enabled	VCXO-PLL Bypass: 0 = VCXO-PLL is enabled. 1 = VCXO-PLL is disabled and bypassed.
VCO_SEL	R/W	0 Value: $f_{VCO} = 2949.12\text{MHz}$	VCO Select: 0 = Selects VCO-0. $f_{VCO} = 2949.12\text{MHz}$ . 1 = Selects VCO-1. $f_{VCO} = 2400\text{-}2500\text{MHz}$ .
POLV	R/W	0 Value: Positive Polarity	VCXO Polarity: 0 = Positive polarity. Use for an external VCXO with a positive $f(V_C)$ characteristics. 1 = Negative polarity. Use for an external VCXO with a negative $f(V_C)$ characteristics.
FVCV	R/W	1 Value: $LFV = V_{DD\_V} / 2$	VCXO-PLL Force VC Control Voltage: 0 = Normal operation. 1 = Forces the voltage at the LFV control pin (VCXO input) to $V_{DD\_V} / 2$ . VCXO-PLL unlocks and the VCXO is forced to its mid-point frequency. FVCV = 1 is the default setting at startup to center the VCXO frequency. FVCV should be cleared after startup to enable the PLL to lock to the reference frequency.

Table 29. PLL Control Register Descriptions (Cont.)

Register Description			
Bit Field Name	Field Type	Default (Binary)	Description
CPV[4:0]	R/W	0 1111 Value: 0.8mA	<p>VCXO-PLL Charge-Pump Current:</p> <p>Controls the charge pump current <math>I_{CPV}</math> of the VCXO-PLL. Charge pump current is the binary value of this register plus one multiplied by <math>50\mu\text{A}</math>.</p> $I_{CPV} = 50\mu\text{A} \times (\text{CPV}[4:0] + 1).$ <p>CPV[4:0] = 00000 sets <math>I_{CPV}</math> to the minimum current of <math>50\mu\text{A}</math>. Maximum charge pump current is 1.6mA. Default setting is 0.8mA: <math>((15 + 1) \times 50\mu\text{A})</math>.</p>
OSVEN	R/W	0	<p>VCXO-PLL Offset Enable:</p> <p>0 = No offset. 1 = Offset enabled. A static phase offset of OFFSET[4:0] is applied to the PFD of the VCXO-PLL.</p>
OFFSETV[4:0]	R/W	0 0000 Value: $0^\circ$	<p>VCXO-PLL Static Phase Offset:</p> <p>Controls the static phase detector offset of the VCXO-PLL. Phase offset is the binary value of this register multiplied by <math>0.9^\circ</math> of the PFD input signal (<math>\text{OFFSET}[4:0] \times f_{\text{PFD}} \div 400</math>). Maximum offset is <math>31 \times 0.9^\circ = 27.9^\circ</math>. Setting OFFSET to <math>0.0^\circ</math> eliminates the thermal noise of an offset current. If the VCXO-PLL input jitter period <math>T_{\text{JIT}}</math> exceeds the average input period: set OFFSET to a value larger than <math>f_{\text{PFD}} \times T_{\text{JIT}} \times 400</math> to achieve a better charge pump linearity and lower in-band noise of the PLL.</p>
CPF[4:0]	R/W	0 0110 Value: 1.4mA	<p>FemtoClock NG-PLL Charge-Pump Current:</p> <p>Controls the charge pump current <math>I_{CPF}</math> of the FemtoClock NG PLL. Charge pump current is the binary value of this register plus one multiplied by <math>200\mu\text{A}</math>.</p> $I_{CPF} = 200\mu\text{A} \times (\text{CPF}[4:0] + 1).$ <p>CPF[4:0] = 00000 sets <math>I_{CPF}</math> to the minimum current of <math>200\mu\text{A}</math>. Maximum charge pump current is 5.6mA. Default setting is 1.4mA: <math>((6 + 1) \times 200\mu\text{A})</math>.</p>

## Input Selection Mode Registers

Table 30. Input Selection Mode Register Bit Field Locations

Bit Field Location								
Register Address	D7	D6	D5	D4	D3	D2	D1	D0
0x20	Reserved	Reserved	Reserved	Reserved	Reserved	IN_BLOCK	Reserved	EN_nMA
0x21	Reserved	Reserved	Reserved	REVS	nM/A[1:0]		Reserved	INT_SEL
0x22	CNTH[7:0]							
0x23	CNTR[1:0]		Reserved	Reserved	Reserved	Reserved	CNTV[1:0]	
0x44	N_MON_0[7:0]							
0x45	Reserved	N_MON_0[14:8]						
0x46	N_MON_1[7:0]							
0x47	Reserved	N_MON_1[14:8]						

Table 31. Input Selection Mode Register Descriptions

Register Description			
Bit Field Name	Field Type	Default (Binary)	Description
N_MON_0[14:0]	R/W	000_0000 0000_0001  Value: ÷1	<p>Clock frequency divider for the CLK_0 input activity monitor.</p> <p>The clock activity monitor compares the device input frequency (<math>f_{IN}</math>) on CLK_0 to the frequency of the VCXO divided by N_MON_0. For optimal operation of the activity monitor, the frequency <math>f_{VCXO} \div N\_MON\_0</math> should match the input frequency at CLK_0.</p> <p>E.g. for <math>f_{IN} = 122.88\text{MHz}</math> at CLK_0 and <math>f_{VCXO} = 122.88\text{MHz}</math>, set <math>N\_MON\_0 = \div 1</math>.</p> <p>The value of the frequency N_MON_0[14:0]_1 divider is binary coded.</p> <p>Range: ÷1 to ÷32767.</p> <p>N_MON_0[14:0] is located in double-buffered registers (see the RB_MODE and TRANSFER bit settings).</p>

Table 31. Input Selection Mode Register Descriptions (Cont.)

Register Description			
Bit Field Name	Field Type	Default (Binary)	Description
N_MON_1[14:0]	R/W	000_0000 0000_0001  Value: ÷1	<p>Clock frequency divider for the CLK_1 input activity monitor:</p> <p>The clock activity monitor compares the device input frequency (<math>f_{IN}</math>) on CLK_1 to the frequency of the VCXO divided by N_MON_1. For optimal operation of the activity monitor, the frequency <math>f_{VCXO} \div N\_MON\_1</math> should match the input frequency at CLK_1.</p> <p>E.g. for <math>f_{IN}=122.88\text{MHz}</math> at CLK_1 and <math>f_{VCXO}=122.88\text{MHz}</math>, set <math>N\_MON\_1 = \div 1</math>. For <math>f_{IN} = 30.72\text{MHz}</math> at CLK_1 and <math>f_{VCXO} = 122.88\text{MHz}</math>, set <math>N\_MON\_1 = \div 4</math>.</p> <p>The value of the frequency N_MON_1[14:0] divider is binary coded.</p> <p>Range: ÷1 to ÷32767.</p> <p>N_MON_1[14:0] is located in double-buffered registers (see the RB_MODE and TRANSFER bit settings).</p>
IN_BLOCK	R/W	0  Value: not blocked	<p>Inactive Input Clock Block:</p> <p>0 = Both input clock signals CLK_0 and CLK_1 are routed to the input clock multiplexer and to the activity detectors.</p> <p>1 = The input clock <i>that is currently not active</i> is gated off (blocked). The blocked input is not monitored for activity.</p> <p>For instance, if CLK_0 is selected as the current PLL reference clock, IN_BLOCK = 1 causes the CLK_1 input to be turned off in order to reduce input signal interference. IN_BLOCK should only be used with manual input reference control.</p>
EN_nMA	R/W	0	<p>Enable Internal Input Switch Controls (only valid when EXT_SEL [1:0] = 10; all other configurations ignore this bit):</p> <p>0 = <a href="#">External-Controlled Holdover – No Expiration Counter</a>.</p> <p>1 = nMA[1:0] control bits set the input selection.</p>
REVS	R/W	0  Value: Disabled	<p>Revertive Switching:</p> <p>The revertive input switching setting is only applicable to the two automatic selection modes shown in <a href="#">Table 13</a>. If nM/A[1:0] = X0, the REVS setting has no meaning.</p> <p>0 = Disabled: Re-validation of a primary clock has no impact on the clock selection.</p> <p>1 = Enabled: Re-validation of the primary clock will cause a new input selection to that clock.</p>
nM/A[1:0]	R/W	00  Value: Manual Selection	<p>Reference Input Selection Mode (only valid when EXT_SEL [1:0] = 10, and EN_nMA = 1):</p> <p>In either of the manual selection modes (nM/A[1:0] = 00 or 10), the VCXO-PLL reference input is selected by INT_SEL. In any of the automatic selection modes, the VCXO-PLL reference input is selected by an internal state machine according to the input LOS states and the INT_SEL bit.</p> <p>00 = Manual Holdover 01 = Automatic selection (no holdover) 10 = Short-term holdover. 11 = Automatic selection with holdover</p>

Table 31. Input Selection Mode Register Descriptions (Cont.)

Register Description					
Bit Field Name	Field Type	Default (Binary)	Description		
INT_SEL	R/W	0  Value: CLK_0 selected/ primary clock	VCXO-PLL Input Reference Selection.		
			INT_SEL	Internal and manual clock selection modes	Automatic modes
			0 1	CLK_0 is reference input CLK_1 is reference input	CLK_0 = primary clock CLK_1 = secondary clock
			If EXT_SEL[1:0] = 00 or 01: INT_SEL has no meaning.		
CNTH[7:0]	R/W	1000 0000 Value: 136ms	Short-term holdover: Hold-off counter period. The device initiates a clock fail-over switch upon counter expiration (zero transition). The counters start to counts backwards after an LOS event is detected. The hold-off counter period is determined by the binary number of VCXO-PLL output pulses divided by CNTR[1:0]. With a VCXO frequency of 122.88MHz and CNTR[1:0] = 10, the counter has a period of (1.066ms × binary setting). After each zero-transition, the counter automatically re-loads to the setting in this register. The default setting is 136ms (VCXO = 122.88MHz: $1/122.88\text{MHz} \times 2^{17} \times 128$ ).		
CNTR[1:0]	R/W	10  Value: $2^{17}$	Short-term Holdover Reference Divider.		
			CNTR[1:0]	CNTH frequency (period; range)	
				122.88MHz VCXO	38.4MHz VCXO
			$00 = f_{\text{VCXO}} \div 2^{15}$	–	1171Hz (0.853ms; 0 – 2 17.6ms)
			$01 = f_{\text{VCXO}} \div 2^{16}$	1875Hz (0.533ms; 0–136ms)	
$10 = f_{\text{VCXO}} \div 2^{17}$	937.5Hz (1.066ms; 0–272ms)				
CNTV[1:0]	R/W	10  Value: 32	Revalidation Counter: Controls the number of required consecutive, valid input reference pulses for clock re-validation on CLK_n in number of input periods. At an LOS event, the re-validation counter loads this setting from the register and counts down by one with every valid, consecutive input signal period. Missing input edges (for one input period) will cause this counter to re-load its setting. An input is re-validated when the counter transitions to zero and the corresponding LOS flag is reset.  00 = 2 (shortest possible) 01 = 16 10 = 32 11 = 64		

## Channel Registers

The content of the channel registers set the channel state, the clock divider the clock phase delay and the power-down state.

Table 32. Channel Register Bit Field Locations

Bit Field Location								
Register Address	D7	D6	D5	D4	D3	D2	D1	D0
0x24: Channel A 0x2C: Channel B 0x34: Channel C 0x3C: Channel D					N_A[7:0] N_B[7:0] N_C[7:0] N_D[7:0]			
0x25: Channel A 0x2D: Channel B 0x35: Channel C 0x3D: Channel D					ΦCLK_A[8:1] ΦCLK_B[8:1] ΦCLK_C[8:1] ΦCLK_D[8:1]			
0x26: Channel A 0x2E: Channel B 0x36: Channel C 0x3E: Channel D	PD_A PD_B PD_C PD_D	Reserved	Reserved	Reserved	Reserved	Reserved	Reserved	ΦCLK_A0 ΦCLK_B0 ΦCLK_C0 ΦCLK_D0
0x58	Reserved	Reserved	EN_QCLK_V	EN_QCLK_A	EN_QCLK_B	EN_QCLK_C	EN_QCLK_D	Reserved

Table 33. Channel Register Descriptions<sup>[a]</sup>

Register Description			
Bit Field Name	Field Type	Default (Binary)	Description
N_x[7:0]	R/W	N_A, N_B: 0000 0001	Output Frequency Divider N: N_x[7:0]                      Divider Value
		Value: ÷3	1000 0000                      ÷1 0000 0000                      ÷2 0000 0001                      ÷3 0000 0010                      ÷4 0000 0011                      ÷5 0000 0100                      ÷6 0000 0110                      ÷8
		N_C, N_D: 0000 0100	
		Value: ÷6	0100 0011                      ÷10 0100 0100                      ÷12 0100 0110                      ÷16 0100 1011                      ÷20 0100 1100                      ÷24 0101 0011                      ÷30 0100 1110                      ÷32 0101 0100                      ÷36 0101 1011                      ÷40 0101 0110                      ÷48 0110 0011                      ÷50 0110 0100                      ÷60 0101 1110                      ÷64 0101 1111                      ÷72 0110 0110                      ÷80 0110 1110                      ÷96 0111 1011                      ÷100 0111 1100                      ÷120 0111 0110                      ÷128 0111 1110                      ÷160

Table 33. Channel Register Descriptions<sup>[a]</sup> (Cont.)

Register Description				
Bit Field Name	Field Type	Default (Binary)	Description	
ΦCLK_x[8:0]	R/W	0 0000 0000	CLK_x phase delay for f <sub>VCO</sub> = 2949.12MHz: Delay in ps = ΦCLK_x × 169ps (512 steps) ΦCLK_x[8:0]	
			0 0000 0000	0ps
			0 0000 0001	169ps
			...	...
			1 1111 1111	86.664ns
			CLK_x phase delay for f <sub>VCO</sub> = 2457.6MHz: Delay in ps = ΦCLK_x × 203ps (512 steps) ΦCLK_x[8:0]	
			0 0000 0000	0ps
			0 0000 0001	203ps
			...	...
			1 1111 1111	103.963ns
PD_x	R/W	0  Value: power-up	0 = Channel x is powered-up 1 = Channel x is power-down	
EN_x	R/W	0  Value: disabled	QCLK_x Channel Output Enable: 0 = All outputs of channel x are disabled at the logic low state 1 = All outputs of channel x are enabled	
EN_QCLK_V	R/W	0  Value: disabled	QCLK_V Output Enable: 0 = QCLK_V is disabled at the logic low state 1 = QCLK_V is enabled	

[a] x = A – D.

## Output Registers

The content of the output registers set the power-down state, the output style and amplitude.

Table 34. Output Register Bit Field Locations

Bit Field Location								
Register Address	D7	D6	D5	D4	D3	D2	D1	D0
0x28: QCLK_A0 0x29: QCLK_A1 0x2A: QCLK_A2	PD_A0 PD_A1 PD_A2	Reserved	Reserved	STYLE_A0 STYLE_A1 STYLE_A2	A_A0[1:0] A_A1[1:0] A_A2[1:0]		Reserved	Reserved
0x30: QCLK_B0 0x31: QCLK_B1 0x32: QCLK_B2	PD_B0 PD_B1 PD_B2	Reserved	Reserved	STYLE_B0 STYLE_B1 STYLE_B2	A_B0[1:0] A_B1[1:0] A_B2[1:0]		Reserved	Reserved
0x38: QCLK_C0 0x39: QCLK_C1	PD_C0 PD_C1	Reserved	Reserved	STYLE_C0 STYLE_C1	A_C0[1:0] A_C1[1:0]		Reserved	Reserved
0x40: QCLK_D0 0x41: QCLK_D1	PD_D0 PD_D1	Reserved	Reserved	STYLE_D0 STYLE_D1	A_D0[1:0] A_D1[1:0]		Reserved	Reserved
0x4B: QCLK_V	PD_V	Reserved	STYLE_V[1:0]		A_V[1:0]		Reserved	Reserved

Table 35. Output Register Descriptions<sup>[a]</sup>

Register Description			
Bit Field Name	Field Type	Default (Binary)	Description
PD_y	R/W	0  Value: power-up	0 = Output QCLK_y is powered up 1 = Output QCLK_y is power-down
PD_V	R/W	0:  Value: power-up	0 = Output QCLK_V is powered up 1 = Output QCLK_V is power-down

Table 35. Output Register Descriptions<sup>[a]</sup>

Register Description															
Bit Field Name	Field Type	Default (Binary)	Description												
A <sub>y</sub> [1:0]	R/W	A <sub>y</sub> [1:0]: 01	QCLK <sub>y</sub> , QCLK <sub>V</sub> Output Amplitude.												
		Value: 500mV	<table border="1"> <tr> <th>Setting for STYLE = 0 (LVDS)</th> <th>Setting for STYLE = 1 (LVPECL)</th> </tr> <tr> <td>A[1:0] = 00: 350mV</td> <td>A[1:0] = 00: 350mV</td> </tr> <tr> <td>A[1:0] = 01: 500mV</td> <td>A[1:0] = 01: 500mV</td> </tr> <tr> <td>A[1:0] = 10: 700mV</td> <td>A[1:0] = 10: 700mV</td> </tr> <tr> <td>A[1:0] = 11: 850mV</td> <td>A[1:0] = 11: 850mV</td> </tr> <tr> <td>Termination: 100Ω across</td> <td>Termination: 50Ω to V<sub>TT</sub><sup>[b]</sup></td> </tr> </table>	Setting for STYLE = 0 (LVDS)	Setting for STYLE = 1 (LVPECL)	A[1:0] = 00: 350mV	A[1:0] = 00: 350mV	A[1:0] = 01: 500mV	A[1:0] = 01: 500mV	A[1:0] = 10: 700mV	A[1:0] = 10: 700mV	A[1:0] = 11: 850mV	A[1:0] = 11: 850mV	Termination: 100Ω across	Termination: 50Ω to V <sub>TT</sub> <sup>[b]</sup>
Setting for STYLE = 0 (LVDS)	Setting for STYLE = 1 (LVPECL)														
A[1:0] = 00: 350mV	A[1:0] = 00: 350mV														
A[1:0] = 01: 500mV	A[1:0] = 01: 500mV														
A[1:0] = 10: 700mV	A[1:0] = 10: 700mV														
A[1:0] = 11: 850mV	A[1:0] = 11: 850mV														
Termination: 100Ω across	Termination: 50Ω to V <sub>TT</sub> <sup>[b]</sup>														
A <sub>V</sub> [1:0]	R/W	A <sub>V</sub> [1:0]: 00 Value: 350mV	<table border="1"> <tr> <th>Setting for STYLE = 0 (LVDS)</th> <th>Setting for STYLE = 1 (LVPECL)</th> </tr> <tr> <td>A[1:0] = 00: 350mV</td> <td>A[1:0] = 00: 350mV</td> </tr> <tr> <td>A[1:0] = 01: 500mV</td> <td>A[1:0] = 01: 500mV</td> </tr> <tr> <td>A[1:0] = 10: 700mV</td> <td>A[1:0] = 10: 700mV</td> </tr> <tr> <td>A[1:0] = 11: 850mV</td> <td>A[1:0] = 11: 850mV</td> </tr> <tr> <td>Termination: 100Ω across</td> <td>Termination: 50Ω to V<sub>TT</sub><sup>[b]</sup></td> </tr> </table>	Setting for STYLE = 0 (LVDS)	Setting for STYLE = 1 (LVPECL)	A[1:0] = 00: 350mV	A[1:0] = 00: 350mV	A[1:0] = 01: 500mV	A[1:0] = 01: 500mV	A[1:0] = 10: 700mV	A[1:0] = 10: 700mV	A[1:0] = 11: 850mV	A[1:0] = 11: 850mV	Termination: 100Ω across	Termination: 50Ω to V <sub>TT</sub> <sup>[b]</sup>
Setting for STYLE = 0 (LVDS)	Setting for STYLE = 1 (LVPECL)														
A[1:0] = 00: 350mV	A[1:0] = 00: 350mV														
A[1:0] = 01: 500mV	A[1:0] = 01: 500mV														
A[1:0] = 10: 700mV	A[1:0] = 10: 700mV														
A[1:0] = 11: 850mV	A[1:0] = 11: 850mV														
Termination: 100Ω across	Termination: 50Ω to V <sub>TT</sub> <sup>[b]</sup>														
STYLE <sub>y</sub>	R/W	0 Value: LVDS	QCLK <sub>y</sub> Output Format: 0 = Output is LVDS (Requires LVDS 100Ω output termination.) 1 = Output is LVPECL (Requires LVPECL 50Ω output termination of to the specified recommended termination voltage.)												
STYLE <sub>V</sub> [1:0]	R/W	10 Value: LVC MOS	QCLK <sub>V</sub> Output Format 00 = Output is LVDS (Requires LVDS 100Ω output termination.) 01 = Output is LVPECL (Requires LVPECL 50Ω termination to V <sub>TT</sub> <sup>[b]</sup> .) 1x = Both QCLK <sub>V</sub> and nQCLK <sub>V</sub> are single-ended LVC MOS 1.8V outputs. QCLK <sub>V</sub> and nQCLK <sub>V</sub> are complementary (180° phase difference).												

[a] y = A0, A1, A2, B0, B1, B2, C0, C1, D0, D1.

[b] For V<sub>TT</sub> (Termination voltage) values (see Table 60).

## Status Registers

Table 36. Status Register Bit Field Locations

Bit Field Location								
Register Address	D7	D6	D5	D4	D3	D2	D1	D0
0x4C	Reserved	Reserved	IE_LOLF	IE_LOLV	IE_REF	IE_HOLD	IE_CLK_1	IE_CLK_0
0x50	Reserved	Reserved	nLS_LOLF	nLS_LOLV	LS_REF	nLS_HOLD	LS_CLK_1	LS_CLK_0
0x51	Reserved	ST_SEL	nST_LOLF	nST_LOLV	ST_REF	nST_HOLD	ST_CLK_1	ST_CLK_0
0x53	Reserved	Reserved	Reserved	Reserved	Reserved	ST_VCOF	Reserved	Reserved

Table 37. Status Register Descriptions<sup>[a]</sup>

Register Description			
Bit Field Name	Field Type	Default (Binary)	Description
IE_LOLF	R/W	0	Interrupt Enable for FemtoClock NG-PLL Loss-of-lock: 0 = Disabled: Setting nLS_LOLF will not cause an interrupt on nINT 1 = Enabled: Setting nLS_LOLF will assert the nINT output (nINT = 0, interrupt)
IE_LOLV	R/W	0	Interrupt Enable for VCXO-PLL Loss-of-lock: 0 = Disabled: Setting nLS_LOLV will not cause an interrupt on nINT 1 = Enabled: Setting nLS_LOLV will assert the nINT output (nINT = 0, interrupt)
IE_CLK <sub>n</sub>	R/W	0	Interrupt Enable for CLK <sub>n</sub> Input Loss-of-signal: 0 = Disabled: Setting LS_CLK <sub>n</sub> will not cause an interrupt on nINT 1 = Enabled: Setting LS_CLK <sub>n</sub> will assert the nINT output (nINT = 0, interrupt)
IE_REF	R/W	0	Interrupt Enable for Input Reference Loss: 0 = Disabled: Setting LS_REF will not cause an interrupt on nINT 1 = Enabled: Setting LS_REF will assert the nINT output (nINT = 0, interrupt)
IE_HOLD	R/W	0	Interrupt Enable for Holdover: 0 = Disabled: Setting nLS_HOLD will not cause an interrupt on nINT 1 = Enabled: Setting nLS_HOLD will assert the nINT output (nINT = 0, interrupt)
nLS_LOLF	R/W	–	FemtoClock NG-PLL Loss-of-lock (latched status of nST_LOLF): Read 0 = ≥1 loss-of-lock events detected after the last status latch clear Read 1 = No loss-of-lock detected after the last status latch clear Write 1 = Clear status latch (clears pending nLS_LOLF interrupt)

Table 37. Status Register Descriptions<sup>[a]</sup> (Cont.)

Register Description			
Bit Field Name	Field Type	Default (Binary)	Description
nLS_LOLV	R/W	–	VCXO-PLL Loss-of-lock (latched status of nST_LOLV): Read 0 = ≥1 loss-of-lock events detected after the last status latch clear Read 1 = No loss-of-lock detected after the last nLS_LOLV clear Write 1 = Clear status latch (clears pending nLS_LOLV interrupt)
LS_CLK <sub>n</sub>	R/W	–	Input CLK <sub>n</sub> status (latched status of ST_CLK <sub>n</sub> ): Read 0 = ≥1 LOS events detected on CLK <sub>n</sub> after the last LS_CLK <sub>n</sub> clear Read 1 = No loss-of-signal detected on CLK <sub>n</sub> input after the last LS_CLK <sub>n</sub> clear Write 1 = Clear LS_CLK <sub>n</sub> status latch (clears pending LS_CLK <sub>n</sub> interrupts on nINT)
ST_SEL	R	–	Input Selection (momentary): Reference Input Selection Status of the state machine. In any input selection mode, reflects the input selected by the state machine. 0 = CLK <sub>0</sub> 1 = CLK <sub>1</sub>
nST_LOLF	R	–	FemtoClock NG-PLL Loss-of-lock (momentary): Read 0 = Loss-of-lock event detected Read 1 = No loss-of-lock detected A latched version of these status bit is available (nLS_LOLV).
nST_LOLV	R	–	VCXO-PLL Loss-of-lock (momentary): Read 0 = Loss-of-lock event detected Read 1 = No loss-of-lock detected A latched version of these status bits is available (nLS_LOLV).
ST_CLK <sub>n</sub>	R	–	Input CLK <sub>n</sub> Status (momentary): 0 = LOS detected on CLK <sub>n</sub> 1 = No LOS detected; CLK <sub>n</sub> input is active A latched version of these status bits are available (LS_CLK <sub>n</sub> ).
LS_REF	R/W	–	PLL Reference Status (latched status of ST_REF): Read 0 = Reference is lost since last reset of this status bit Read 1 = Reference is valid since last reset of this status bit Write 1 = Clear LS_REF status latch (clears pending LS_REF interrupts on nINT).

Table 37. Status Register Descriptions<sup>[a]</sup> (Cont.)

Register Description			
Bit Field Name	Field Type	Default (Binary)	Description
nLS_HOLD	R/W	–	Holdover Status Indicator (latched status of ST_HOLD): Read 0 = VCXO-PLL has entered holdover state $\geq 1$ times after reset of this status bit Read 1 = VCXO-PLL is (or attempts to) lock(ed) to an input clock Write 1 = Clear status latch (clears pending nLS_HOLD interrupt)
ST_VCOF	R	–	FemtoClock NG-PLL Calibration Status (momentary): Read 0 = FemtoClock NG PLL auto-calibration is completed Read 1 = FemtoClock NG PLL calibration is active (not completed)
ST_REF	R	–	Input Reference Status (momentary): 0 = No input reference present. 1 = Input reference is present at the clock selected input clock.
nST_HOLD	R	–	Holdover Status Indicator (momentary): 0 = VCXO-PLL in holdover state, not locked to any input clock 1 = VCXO-PLL is (or attempts to) lock(ed) to input clock A latched version of this status bit is available (nLS_HOLD).

[a] CLK<sub>n</sub> = CLK\_0, CLK\_1.

## General Control Registers

Table 38. General Control Register Bit Field Locations

Bit Field Location								
Register Address	D7	D6	D5	D4	D3	D2	D1	D0
0x55	INIT_CLK	Reserved	Reserved	Reserved	Reserved	Reserved	Reserved	Reserved
0x56	RELOCK	Reserved	Reserved	Reserved	Reserved	Reserved	Reserved	Reserved
0x57	PB_CAL	Reserved	Reserved	Reserved	Reserved	Reserved	Reserved	CPOL

Table 39. General Control Register Descriptions

Register Description			
Bit Field Name	Field Type	Default (Binary)	Description
INIT_CLK	W only Auto-Clear	X	Set INIT_CLK = 1 to initialize divider functions. Required as part of the startup procedure.
RELOCK	W only Auto-Clear	X	Setting this bit to 1 will force the FemtoClock NG PLL to re-lock.
PB_CAL	W only Auto-Clear	X	Precision Bias Calibration: Setting this bit to 1 will start the calibration of an internal precision bias current source. The bias current is used as a reference for outputs configured as LVDS and as a reference for the charge pump currents. This bit will auto-clear after the calibration completed. Set as part of the startup procedure.
CPOL	R/W	0	SPI Read Operation SCLK Polarity: 0 = Data bits on SDIO/SDO are output at the falling edge of SCLK edge. 1 = Data bits on SDIO/SDO are output at the rising edge of SCLK edge.

## Debug Control Status Register

Table 40. Debug Control Status Register Bit Field Locations

Bit Field Location								
Register Address	D7	D6	D5	D4	D3	D2	D1	D0
0x4E	Reserved	Reserved				STAT_PB[5:0]		

Table 41. Debug Control Register Descriptions

Register Description			
Bit Field Name	Field Type	Default (Binary)	Description
STAT_PB[5:0]	R only	XX XXXX	Precision bias current (result of the auto-calibration).

## Precision Bias Control Registers

Table 42. Precision Bias Control Register Bit Field Locations

Bit Field Location								
Register Address	D7	D6	D5	D4	D3	D2	D1	D0
0x63	Reserved				OVERRIDE_CURR[5:0]			OVERRIDE_CAL

Table 43. Precision Bias Control Register Descriptions

Register Description			
Bit Field Name	Field Type	Default (Binary)	Description
OVERRIDE_CURR[5:0]	R/W	00 0000	Overwrite precision bias current.
OVERRIDE_CAL	R/W	0	0 = no overwrite 1 = bit pattern in OVERRIDE_CURR[5:0] overwrites the internal precision current auto-calibration. It is recommended to set OVERRIDE_CURR[0] = 0.

## Electrical Characteristics

### Absolute Maximum Ratings

The absolute maximum ratings are stress ratings only. Stresses greater than those listed below can cause permanent damage to the device. Functional operation of the 8V19N470 at absolute maximum ratings is not implied. Exposure to absolute maximum rating conditions may affect device reliability.

Table 44. Absolute Maximum Ratings

Item	Rating
Supply Voltage, $V_{DD\_V}$	3.6V
Inputs	-0.5V to $V_{DD\_V} + 0.5V$
Outputs, $V_O$ (LVCMOS)	-0.5V to $V_{DDO\_V} + 0.5V$
Outputs, $I_O$ (LVPECL) Continuous Current Surge Current	50mA 100mA
Outputs, $I_O$ (LVDS) Continuous Current Surge Current	50mA 100mA
Junction Temperature, $T_J$	150°C
Storage Temperature, $T_{STG}$	-65°C to 150°C
ESD - Human Body Model <sup>[a]</sup>	1500
ESD - Charged Device Model <sup>[a]</sup>	750

[a] According to JEDEC JS-001-2012/JESD22-C101.

### Recommended Operating Conditions

Table 45. Recommended Operating Conditions

Item	Rating
Supply Voltage, $V_{DD\_V}$	3.3V
Operating Junction Temperature, $T_J$ <sup>[a]</sup>	$\leq 130^\circ\text{C}$
Board Temperature, $T_B$	$\leq 105^\circ\text{C}$

[a] 130°C/10year lifetime is based on the evaluation of intrinsic wafer process technology reliability metrics. The limiting wafer level reliability factor for this technology with respect to high temperature operation is electromigration. The device is verified to the maximum operating junction temperature through simulation.

## DC Characteristics

### Pin Characteristics

Table 46. Pin Characteristics,  $V_{DD\_V} = 3.3V \pm 5\%$ ,  $V_{DDO\_V} = (3.3V, 2.5V \text{ or } 1.8V) \pm 5\%$ ,  $T_A = -40^\circ\text{C to } +85^\circ\text{C}$

Symbol	Parameter		Test Conditions	Minimum	Typical	Maximum	Units
$C_{IN}$	Input Capacitance	OSC, nOSC			2	4	pF
		Other inputs			2	4	pF
$R_{PD}$	Input Pull-down Resistor	SCLK, EXT_SEL[1:0], CLK_n, nCLK_n			51		k $\Omega$
$R_{PU}$	Input Pull-up Resistor	nCLK_n, nCS, nRESET			51		k $\Omega$
$R_{OUT}$	LVC MOS Output Impedance	LOCK_F, LOCK_V, nINT			25		$\Omega$

Table 47. Power Supply DC Characteristics,  $V_{DD\_V} = 3.3V \pm 5\%$ ,  $V_{DDO\_V} = (3.3V, 2.5V \text{ or } 1.8V) \pm 5\%$ ,  $T_A = -40^\circ\text{C to } +85^\circ\text{C}$

Symbol	Parameter	Test Conditions	Minimum	Typical	Maximum	Units
$V_{DD\_V}$	Core Supply Voltage		3.135	3.3	3.465	V
$V_{DDO\_V}$	Output Supply Voltage		1.71	1.8, 2.5, 3.3	3.465	V

Table 48. Typical Power Supply DC Current Characteristics (LVDS),  $V_{DD\_V} = 3.3V \pm 5\%$ ,  $T_A = -40^\circ C$  to  $+85^\circ C$ <sup>[a]</sup>

Symbol	Supply Pin Current		Test Case						Unit
			1	2	3	4	5	6	
$I_{DD\_V}$	Core	$V_{DD\_V}$	3.3						V
	Current through $V_{DD\_V}$ pins		325						mA
$I_{DDO\_V}$	QCLK_y	Style	LVDS	LVDS	LVDS	LVDS	LVDS	LVDS	–
		State	On	On	On	On	On	On	–
		Amplitude	350	500	700	850	350	500	mV
		$V_{DDO\_V}$	3.3	3.3	3.3	3.3	1.8	1.8	V
	Current through $V_{DDO\_V}$ pins		111	161	203	252	103	147	mA
$P_{TOT}$	Total Device Power Consumption		1.439	1.603	1.743	1.906	1.257	1.337	W
$P_{TOT, SYS}$	Total System Power Consumption <sup>[b]</sup>		1.439	1.603	1.743	1.906	1.257	1.337	W

[a] Device configuration:  $VCO\_SEL = 0$  ( $f_{VCO} = 2949.12MHz$ );  $N_A = N_B = N_C = N_D = \div 2$ ,  $f_{QCLK\_y} = 1474.56MHz$ ;  $P_{V0} = P_{V1} = M_{V0} = \div 1000$ ,  $FDF = \div 1$ ,  $P_F = \div 1$ ,  $M_F = \div 12$ ,  $ICPV = 1.1mA$ ,  $ICPF = 3.4mA$ .  
Supply current is independent of the output frequency configuration.  
QCLK\_y outputs terminated 100Ω.

[b] Includes total device power consumption and the power dissipated in external output termination components.

Table 49. Typical Power Supply DC Current Characteristics (LVPECL),  $V_{DD\_V} = 3.3V \pm 5\%$ ,  $T_A = -40^\circ C$  to  $+85^\circ C$

Symbol	Supply Pin Current		Test Case						Unit
			1	2	3	4	5	6	
$I_{DD\_V}$	Core	$V_{DD\_V}$	3.3						V
	Current through $V_{DD\_V}$ pins		325	325	326	329	334	335	mA
$I_{DDO\_V}$	QCLK_y	Style	LVPECL	LVPECL	LVPECL	LVPECL	LVPECL	LVPECL	–
		State	On	On	On	On	On	On	–
		Amplitude	350	500	700	850	350	500	mV
		$V_{DDO\_V}$	3.3	3.3	3.3	3.3	1.8	1.8	V
	Current through $V_{DDO\_V}$ pins		246	276	317	348	244	274	mA
$P_{TOT}$	Total Device Power Consumption		1.34	1.39	1.47	1.54	1.35	1.39	W
$P_{TOT, SYS}$	Total System Power Consumption <sup>[a]</sup>		1.88	1.98	2.12	2.23	1.54	1.60	W

[a] Includes total device power consumption and the power dissipated in external output termination components.

Table 50. LVCMOS DC Characteristics,  $V_{DD\_V} = 3.3V \pm 5\%$ ,  $V_{DDO\_V} = (3.3V, 2.5V \text{ or } 1.8V) \pm 5\%$ ,  $T_A = -40^\circ\text{C to } +85^\circ\text{C}$ 

Symbol	Parameter		Test Conditions	Minimum	Typical	Maximum	Units
Control inputs EXT_SEL0, EXT_SEL1, nRESET (1.8V logic and 3.3V tolerance)							
$V_{IH}$	Input High Voltage			1.17		$V_{DD\_V}$	V
$V_{IL}$	Input Low Voltage			-0.3		0.63	V
$I_{IH}$	Input High Current	EXT_SEL[1:0] inputs with pull-down resistor	$V_{DD\_V} = 3.3V, V_{IN} = 3.3V$			150	$\mu\text{A}$
		nRESET input with pull-up resistor				5	
$I_{IL}$	Input Low Current	EXT_SEL[1:0] inputs with pull-down resistor	$V_{DD\_V} = 3.465V, V_{IN} = 0V$				$\mu\text{A}$
		nRESET input with pull-up resistor			-150		
Control inputs nCS, SCLK and SDIO (when input) (1.8V logic, hysteresis)							
$V_{T+}$	Positive-going Input Threshold Voltage			0.72		1.26	V
$V_{T-}$	Negative-going Input Threshold Voltage			0.54		1.08	V
$V_H$	Hysteresis Voltage		$V_{T+} - V_{T-}$	0.18		0.72	V
$I_{IH}$	Input High Current	SCLK input with pull-down resistor	$V_{DD\_V} = 3.3V, V_{IN} = 1.8V$			150	$\mu\text{A}$
		nCS input with pull-up resistor				5	
		SDIO (when input)				5	
$I_{IL}$	Input Low Current	SCLK input with pull-down resistor	$V_{DD\_V} = 3.465V, V_{IN} = 0V$				$\mu\text{A}$
		nCS input with pull-up resistor			-150		
		SDIO (when input)			-5		
Control outputs configured to 3.3V							
$V_{OH}$	Output High Voltage	SDO, nINT, LOCK_F, LOCK_V, SDIO (when output)	$I_{OH} = -4\text{mA}$	2.0			V
$V_{OL}$	Output Low Voltage		$I_{OL} = 4\text{mA}$			0.55	V
Control outputs configured to 1.8V							
$V_{OH}$	Output High Voltage	SDO, nINT, LOCK_F, LOCK_V, SDIO (when output)	$I_{OH} = -4\text{mA}$	1.35		1.8	V
$V_{OL}$	Output Low Voltage		$I_{OL} = 4\text{mA}$			0.45	V

Table 51. Differential Input DC Characteristics,  $V_{DD\_V} = 3.3V \pm 5\%$ ,  $V_{DDO\_V} = (3.3V, 2.5V \text{ or } 1.8V) \pm 5\%$ ,  $T_A = -40^\circ\text{C to } +85^\circ\text{C}$

Symbol	Parameter		Test Conditions	Minimum	Typical	Maximum	Units
$I_{IH}$	Input High Current	Input with pull-down resistor <sup>[a]</sup>	$V_{DD\_V} = V_{IN} = 3.465V$			150	$\mu\text{A}$
		Input with pull-up/pull-down resistor <sup>[b]</sup>				150	$\mu\text{A}$
$I_{IL}$	Input Low Current	Input with pull-down resistor <sup>[a]</sup>	$V_{DD\_V} = 3.465V, V_{IN} = 0V$	-150			$\mu\text{A}$
		Input with pull-up/pull-down resistor <sup>[b]</sup>		-150			$\mu\text{A}$

[a] Non-Inverting inputs: CLK\_0, CLK\_1, OSC.

[b] Inverting inputs: nCLK\_0, nCLK\_1, nOSC.

Table 52. LVPECL DC Characteristics (QCLK\_y, QREF\_r, STYLE = 1),  $V_{DD\_V} = 3.3V \pm 5\%$ ,  $V_{DDO\_V} = (3.3V, 2.5V \text{ or } 1.8V) \pm 5\%$ ,  $T_A = -40^\circ\text{C to } +85^\circ\text{C}$

Symbol	Parameter	Test Conditions	Minimum	Typical	Maximum	Units
$V_{OH}$	Output High Voltage <sup>[a] [b]</sup>	350mV amplitude setting	$V_{DDO\_V} - 1.00$	$V_{DDO\_V} - 0.88$	$V_{DDO\_V} - 0.76$	V
		500mV amplitude setting	$V_{DDO\_V} - 1.02$	$V_{DDO\_V} - 0.90$	$V_{DDO\_V} - 0.78$	V
		700mV amplitude setting	$V_{DDO\_V} - 1.04$	$V_{DDO\_V} - 0.94$	$V_{DDO\_V} - 0.83$	V
		850mV amplitude setting	$V_{DDO\_V} - 1.06$	$V_{DDO\_V} - 0.96$	$V_{DDO\_V} - 0.86$	V
$V_{OL}$	Output Low Voltage <sup>[a] [b]</sup>	350mV amplitude setting	$V_{DDO\_V} - 1.38$	$V_{DDO\_V} - 1.25$	$V_{DDO\_V} - 1.13$	V
		500mV amplitude setting	$V_{DDO\_V} - 1.54$	$V_{DDO\_V} - 1.42$	$V_{DDO\_V} - 1.30$	V
		700mV amplitude setting	$V_{DDO\_V} - 1.75$	$V_{DDO\_V} - 1.62$	$V_{DDO\_V} - 1.51$	V
		850mV amplitude setting	$V_{DDO\_V} - 1.90$	$V_{DDO\_V} - 1.79$	$V_{DDO\_V} - 1.68$	V

[a] Outputs terminated with  $50\Omega$  to  $V_{TT}$ . For termination voltage  $V_{TT}$  values (see Table 60).

[b] 700mV and 850mV amplitude settings are only available at  $V_{DDO\_V} \geq 2.5V$ .

Table 53. LVDS DC Characteristics (QCLK\_y, QREF\_r, STYLE = 0),  $V_{DD\_V} = 3.3V \pm 5\%$ ,  $V_{DDO\_V} = (3.3V, 2.5V \text{ or } 1.8V) \pm 5\%$ ,  $T_A = -40^\circ\text{C to } +85^\circ\text{C}$

Symbol	Parameter	Test Conditions	Minimum	Typical	Maximum	Units
$V_{OS}$	Offset Voltage <sup>[a] [b]</sup>	350mV amplitude setting	$V_{DDO\_V} - 1.146$	$V_{DDO\_V} - 0.982$	$V_{DDO\_V} - 0.809$	V
		500mV amplitude setting	$V_{DDO\_V} - 1.249$	$V_{DDO\_V} - 1.084$	$V_{DDO\_V} - 0.928$	V
		700mV amplitude setting	$V_{DDO\_V} - 1.351$	$V_{DDO\_V} - 1.198$	$V_{DDO\_V} - 1.026$	V
		850mV amplitude setting	$V_{DDO\_V} - 1.460$	$V_{DDO\_V} - 1.296$	$V_{DDO\_V} - 1.131$	V
$\Delta V_{OS}$	$V_{OS}$ Magnitude Change		-	18	50	mV

[a]  $V_{OS}$  changes with  $V_{DDO\_V}$ .

[b] 750mV and 1000mV amplitude settings are only available at  $V_{DDO\_V} \geq 2.5V$ .

## AC Characteristics

Table 54. AC Characteristics,  $V_{DD\_V} = 3.3V \pm 5\%$ ,  $V_{DDO\_V} = (3.3V, 2.5V \text{ or } 1.8V) \pm 5\%$ ,  $T_A = -40^\circ\text{C to } +85^\circ\text{C}$ <sup>[a]</sup> <sup>[b]</sup>

Symbol	Parameter		Test Conditions	Minimum	Typical	Maximum	Units
$f_{VCO}$	VCO Frequency Range		VCO-0	2920	2949.12	3000	MHz
			VCO-1	2400	2457.6	2500	MHz
$f_{OUT}$	Output Frequency	VCO-0	QCLK_y, N = ÷1		2949.12		MHz
			QCLK_y, N = ÷2		1474.56		MHz
			QCLK_y, N = ÷3		983.04		MHz
			QCLK_y, N = ÷4		737.28		MHz
			QCLK_y, N = ÷6		491.52		MHz
			QCLK_y, N = ÷8		368.64		MHz
			QCLK_y, N = ÷12		245.76		MHz
			QCLK_y, N = ÷24		122.88		MHz
			QCLK_y, N = ÷96		30.72		MHz
		VCO-1	QCLK_y, N = ÷1		2457.6		MHz
			QCLK_y, N = ÷2		1228.8		MHz
			QCLK_y, N = ÷4		614.4		MHz
			QCLK_y, N = ÷8		307.2		MHz
			QCLK_y, N = ÷10		245.76		MHz
		QCLK_y, N = ÷16		153.6		MHz	
		QCLK_y, N = ÷20		122.88		MHz	
$\Delta f_{OUT}$	Output Frequency Accuracy		Integer output divider, N[A – D]			0	ppb
$f_{IN}$	Input Frequency		CLK_n	0.008		307.2	MHz
$f_{VCXO}$	VCXO Frequency			25	122.88	250	MHz
$V_{IN}$	Input Voltage Amplitude <sup>[c]</sup>	CLK_n		0.15		1.2	V
$V_{DIFF\_IN}$	Differential Input Voltage Amplitude <sup>[c], [d]</sup>	CLK_n		0.3		2.4	V
$V_{CMR}$	Common Mode Input Voltage			1.0		$V_{DD\_V} - (V_{IN} / 2)$	V
odc	Output Duty Cycle		QCLK_y	45	50	55	%
$t_R / t_F$	Output Rise/Fall Time, Differential		QCLK_y (LVPECL), 20% to 80%		146	250	ps
			QCLK_y (LVDS), 20% to 80%		146	250	ps
	Output Rise/Fall Time		LVC MOS outputs, 20% to 80%			1	ns

Table 54. AC Characteristics,  $V_{DD\_V} = 3.3V \pm 5\%$ ,  $V_{DDO\_V} = (3.3V, 2.5V \text{ or } 1.8V) \pm 5\%$ ,  $T_A = -40^\circ\text{C to } +85^\circ\text{C}$ <sup>[a]</sup> <sup>[b]</sup>

Symbol	Parameter	Test Conditions	Minimum	Typical	Maximum	Units	
$V_{O(PP)}$ <sup>[e]</sup>	LVPECL Output Voltage Swing, Peak-to-peak, (see Table 58)	350mV amplitude	1474.56MHz 491.52MHz	366 352	384 368	402 382	mV
		500mV amplitude	1474.56MHz 491.52MHz	498 485	513 500	528 515	mV
		700mV amplitude	1474.56MHz 491.52MHz	692 666	714 689	735 711	mV
		850mV amplitude	1474.56MHz 491.52MHz	822 802	847 825	872 849	mV
	LVPECL Differential Output Voltage Swing, Peak-to-peak, (see Table 58)	350mV amplitude	1474.56MHz 491.52MHz	713 703	768 736	800 764	mV
		500mV amplitude	1474.56MHz 491.52MHz	997 970	1027 1000	1057 1031	mV
		700mV amplitude	1474.56MHz 491.52MHz	1385 1333	1427 1378	1470 1422	mV
		850mV amplitude	1474.56MHz 491.52MHz	1643 1604	1694 1651	1745 1698	mV
$V_{OD}$ <sup>[f]</sup>	LVDS Output Voltage Swing, Peak-to-peak, 1474.56MHz, (see Table 58)	350mV amplitude	1474.56MHz 491.52MHz	250 298	275 314	301 329	mV
		500mV amplitude	1474.56MHz 491.52MHz	362 430	391 446	419 462	mV
		700mV amplitude	1474.56MHz 491.52MHz	496 602	571 637	646 673	mV
		850mV amplitude	1474.56MHz 491.52MHz	621 743	708 781	794 819	mV
	LVDS Differential Output Voltage Swing, Peak-to-peak, 1474.56MHz, (see Table 58)	350mV amplitude	1474.56MHz 491.52MHz	500 596	550 627	601 658	mV
		500mV amplitude	1474.56MHz 491.52MHz	724 861	781 892	838 924	mV
		700mV amplitude	1474.56MHz 491.52MHz	993 1203	1142 1274	1291 1346	mV
		850mV amplitude	1474.56MHz 491.52MHz	1243 1487	1415 1563	1588 1639	mV
$t_{sk(o)}$	Output Skew; NOTE <sup>[g]</sup> <sup>[h]</sup> All delays set to 0.	QCLK_y (same N divider)		41	80 65 <sup>[i]</sup>	ps	
		QCLK_y (any N divider, incident rising edge)		34	80 60 <sup>i</sup>	ps	
$\Delta\Phi$	Output Isolation between any neighboring clock output	$f_{OUT} = 1474.56\text{MHz}$ <sup>[j]</sup>	70.5	74.2		dB	
		$f_{OUT} = 368.64\text{MHz}$ <sup>[k]</sup>	83	86.9		dB	

Table 54. AC Characteristics,  $V_{DD\_V} = 3.3V \pm 5\%$ ,  $V_{DDO\_V} = (3.3V, 2.5V \text{ or } 1.8V) \pm 5\%$ ,  $T_A = -40^\circ\text{C to } +85^\circ\text{C}$ <sup>[a]</sup> <sup>[b]</sup>

Symbol	Parameter	Test Conditions	Minimum	Typical	Maximum	Units
$t_{D, LOS}$	LOS State Detected (measured in input reference periods)	$f_{CLK} = 122.88\text{MHz}$ $f_{CLK} = 245.76\text{MHz}$			2 3	$T_{CLK}$
$t_{D, LOCK}$	PLL Lock Detect: PLL re-lock time after a short-term holdover scenario. Measured from LOS to both PLLs lock-detect asserted; initial frequency error < 200ppm. Measured in External-Controlled Holdover mode transition to external manual mode.	1st PLL bandwidth: 100Hz 20Hz		13.28 141	300 300	ms
$t_{D, RES}$	PLL Lock Residual Time Error: Refer to PLL lock detect $t_{D, LOCK}$ . Reference point: final value of clock output phase after all phase transitions settled. Measured in automatic switch mode. Measured in automatic with holdover mode. Measured in automatic with holdover mode.			0.14	20	ns
$\Delta f_{HOLD}$	Holdover Accuracy: Maximum frequency deviation during a holdover duration of 200ms and after the clock re-validate event. Measured in External-Controlled Holdover mode transition to external manual modes.	1st PLL bandwidth: 100Hz 20Hz		3.52 1.3	$\pm 5.0$ $\pm 5.0$	ppm
$t_{D, RES-H}$	Holdover Residual Error: Measured 50ms after the reference clock re-appeared in a holdover scenario. Reference point: final value of clock output phase after all phase transitions settled. Measured in automatic with holdover mode.			6.85	$\pm 8.138$	ns

[a] Electrical parameters are guaranteed over the specified ambient operating temperature range, which is established when the device is mounted in a test socket with maintained transverse airflow greater than 500lfpm. The device will meet specifications after thermal equilibrium has been reached under these conditions.

[b] VCXO-PLL bandwidth = 100Hz.

[c]  $V_{IL}$  should not be less than -0.3V and  $V_{IH}$  should not be greater than  $V_{DD\_V}$ .

[d] Common Mode Input Voltage is defined as the cross-point voltage.

[e] Outputs terminated with  $50\Omega$  to  $V_{TT}$ . For termination voltage  $V_{TT}$  values (see Table 60).

[f] LVDS outputs terminated  $100\Omega$  across terminals.

[g] This parameter is defined in accordance with JEDEC standard 65.

[h] Defined as skew between outputs at the same supply voltage and with equal load conditions. Measured at the differential cross points.

[i] Excluding QCLKC0.

[j] 0–2949.12MHz.

[k] 0–737.28MHz.

Clock Phase Noise Characteristics

**Conditions for Phase Noise Characteristics:**

VCXO characteristics:  $f = 30.72\text{MHz}$  and phase noise:  $-96\text{dBc/Hz}$  (10Hz),  $-127\text{dBc/Hz}$  (100Hz),  $-144\text{dBc/Hz}$  (1kHz),  $-159\text{dBc/Hz}$  (10kHz),  $-162\text{dBc/Hz}$  (100kHz)

- Input reference frequency: 30.72MHz
- VCXO-PLL bandwidth: 5Hz
- VCXO-PLL charge pump current: 1.1mA
- FemtoClock-NG PLL bandwidth: 139kHz
- $V_{DD\_V} = 3.3\text{V}$ ,  $T_A = 25^\circ\text{C}$

Figure 9. 1474.56MHz Output Phase Noise ( $f_{\text{VCXO}} = 30.72\text{MHz}$ )

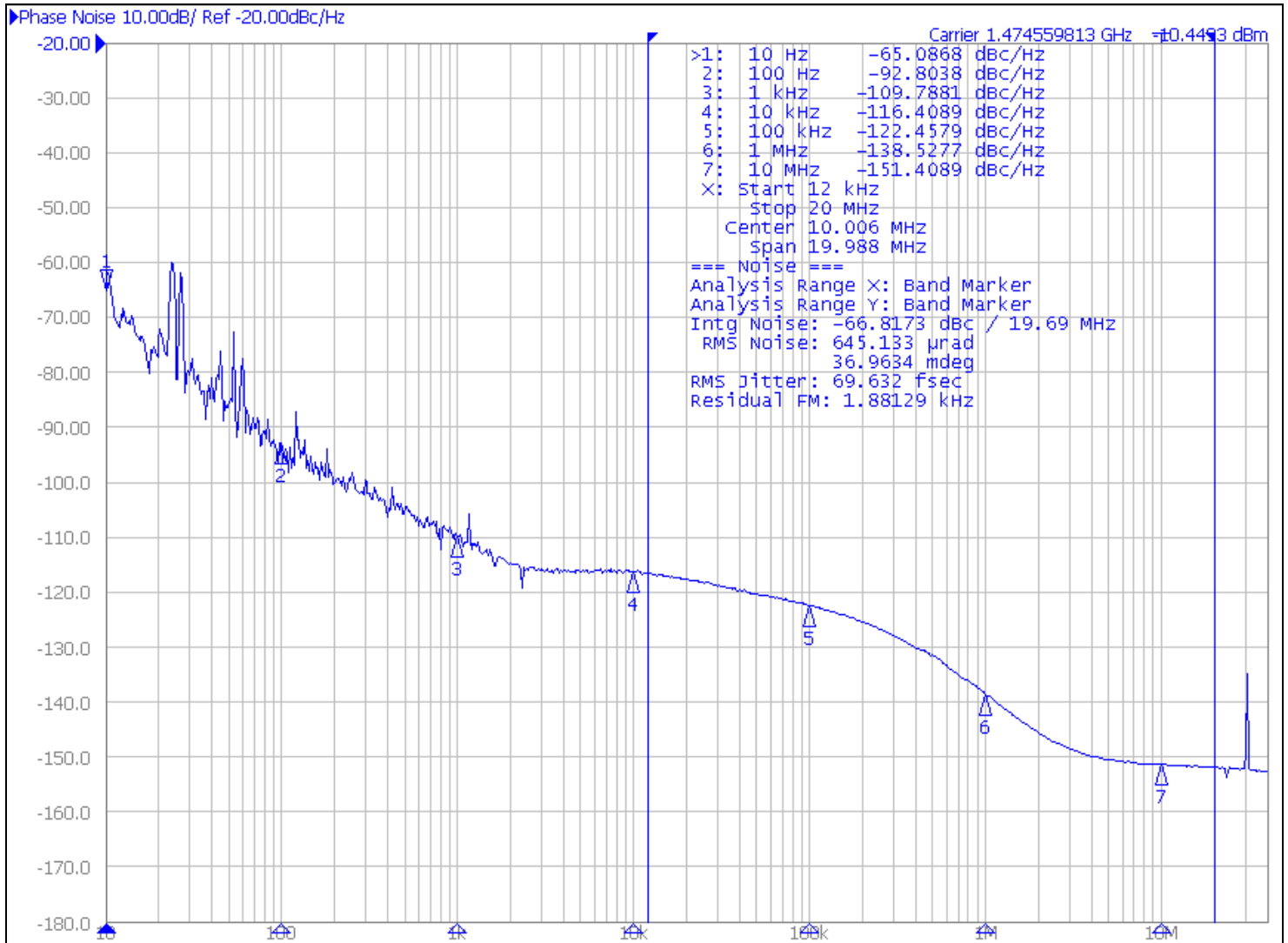

Figure 10. 983.04MHz Output Phase Noise ( $f_{VCXO} = 30.72\text{MHz}$ )

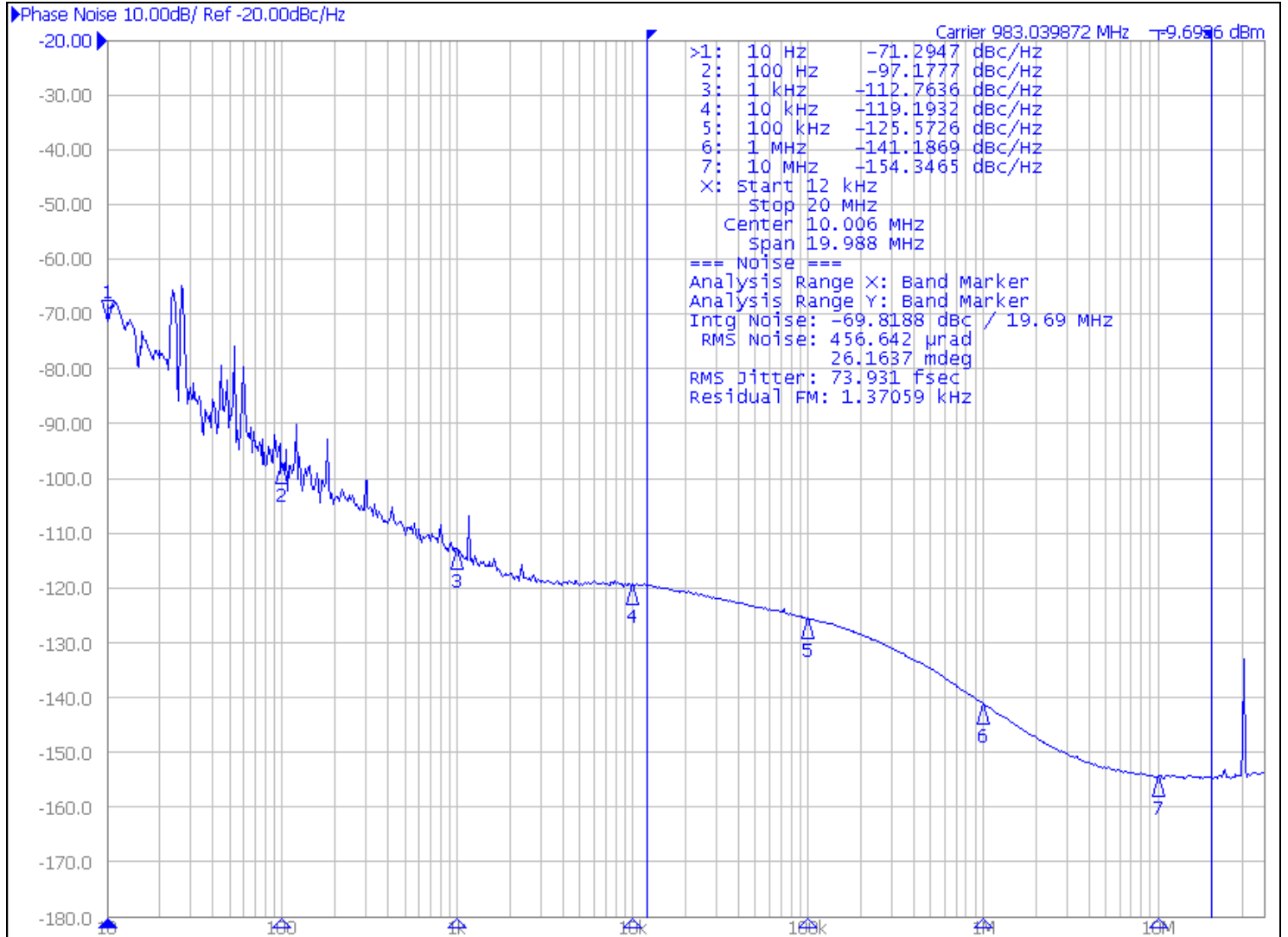

Figure 11. 737.28MHz Output Phase Noise ( $f_{VCO} = 30.72\text{MHz}$ )

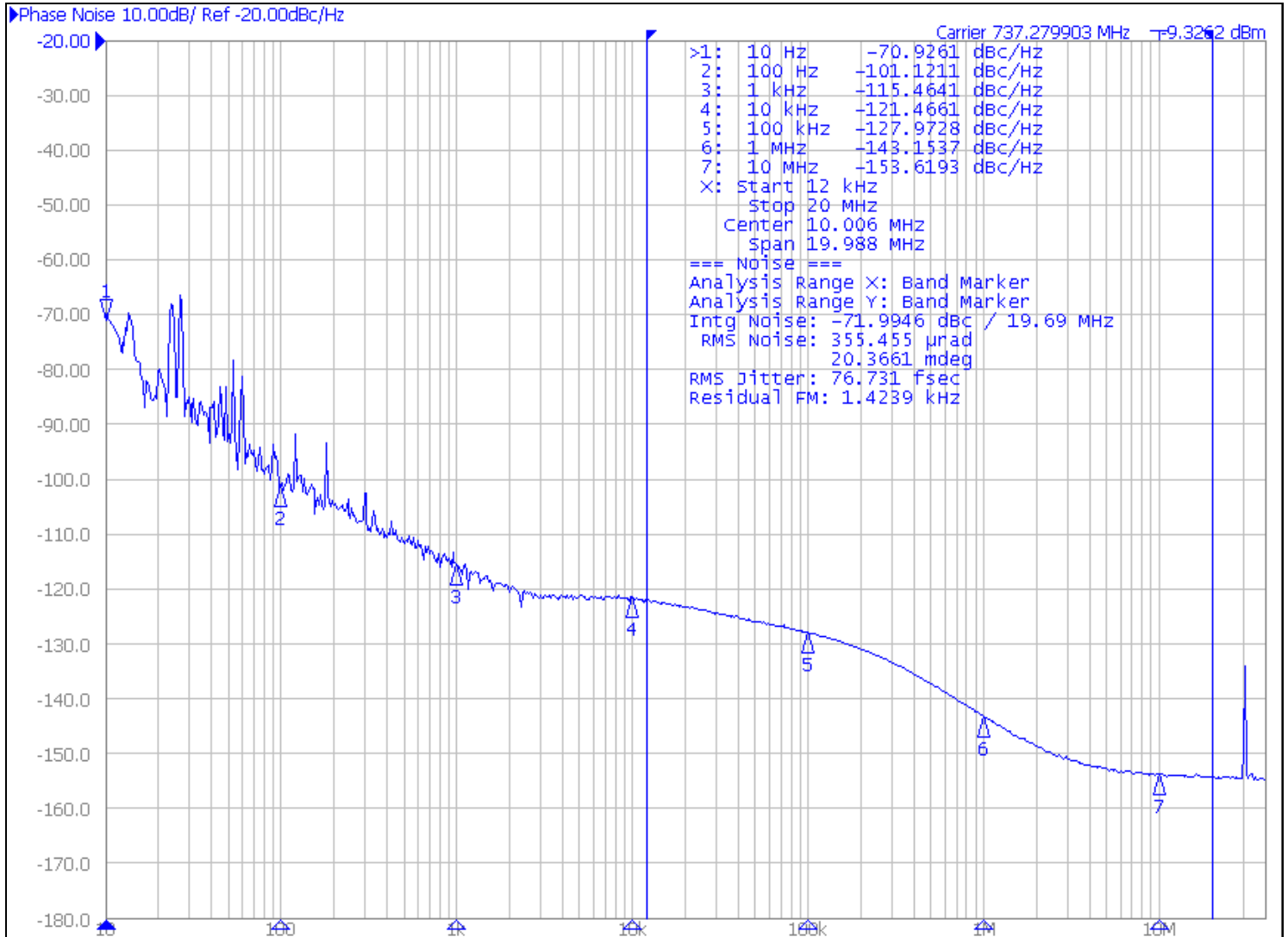

Figure 12. 491.52MHz Output Phase Noise

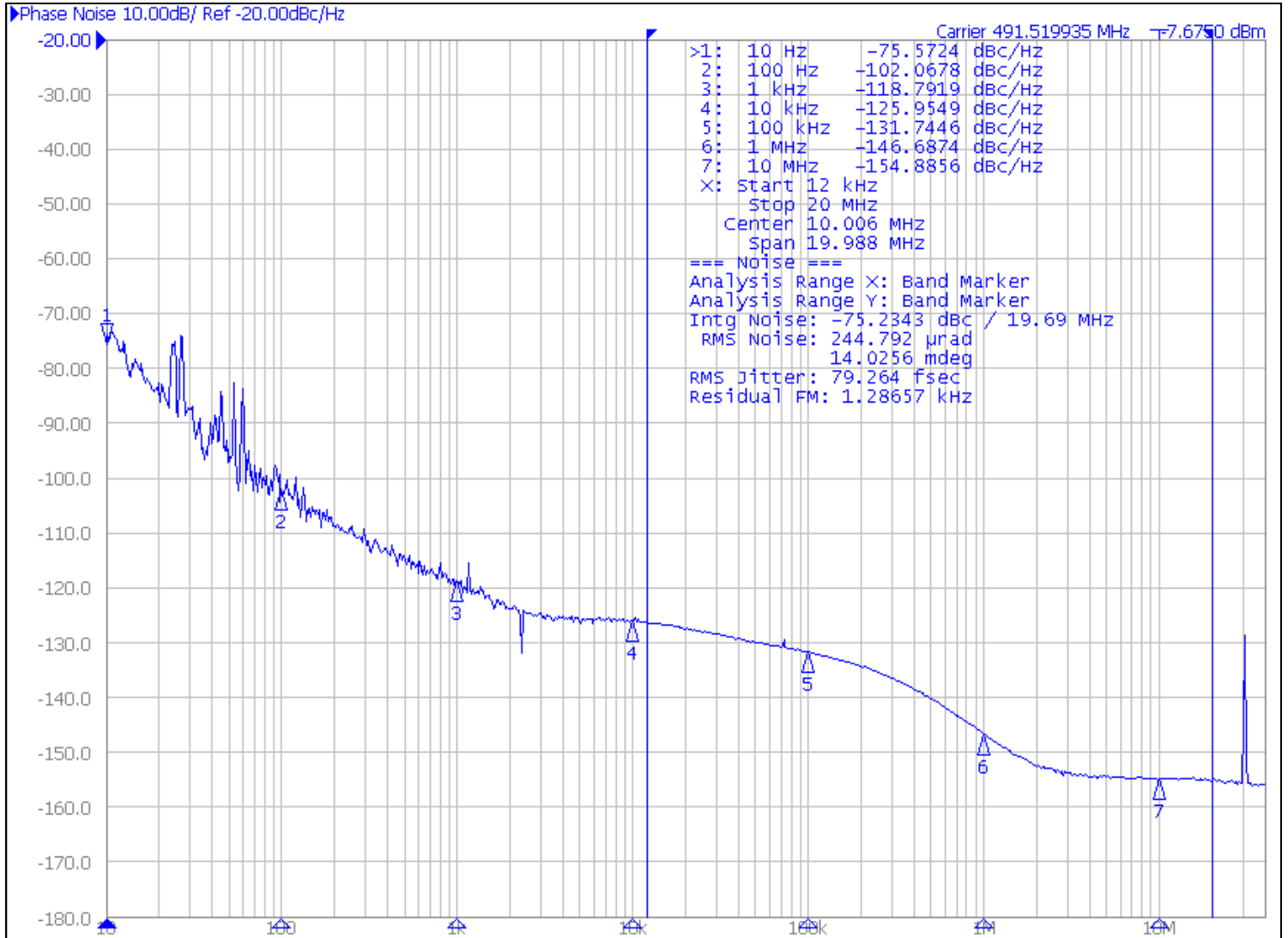

Figure 13. 368.64MHz Output Phase Noise

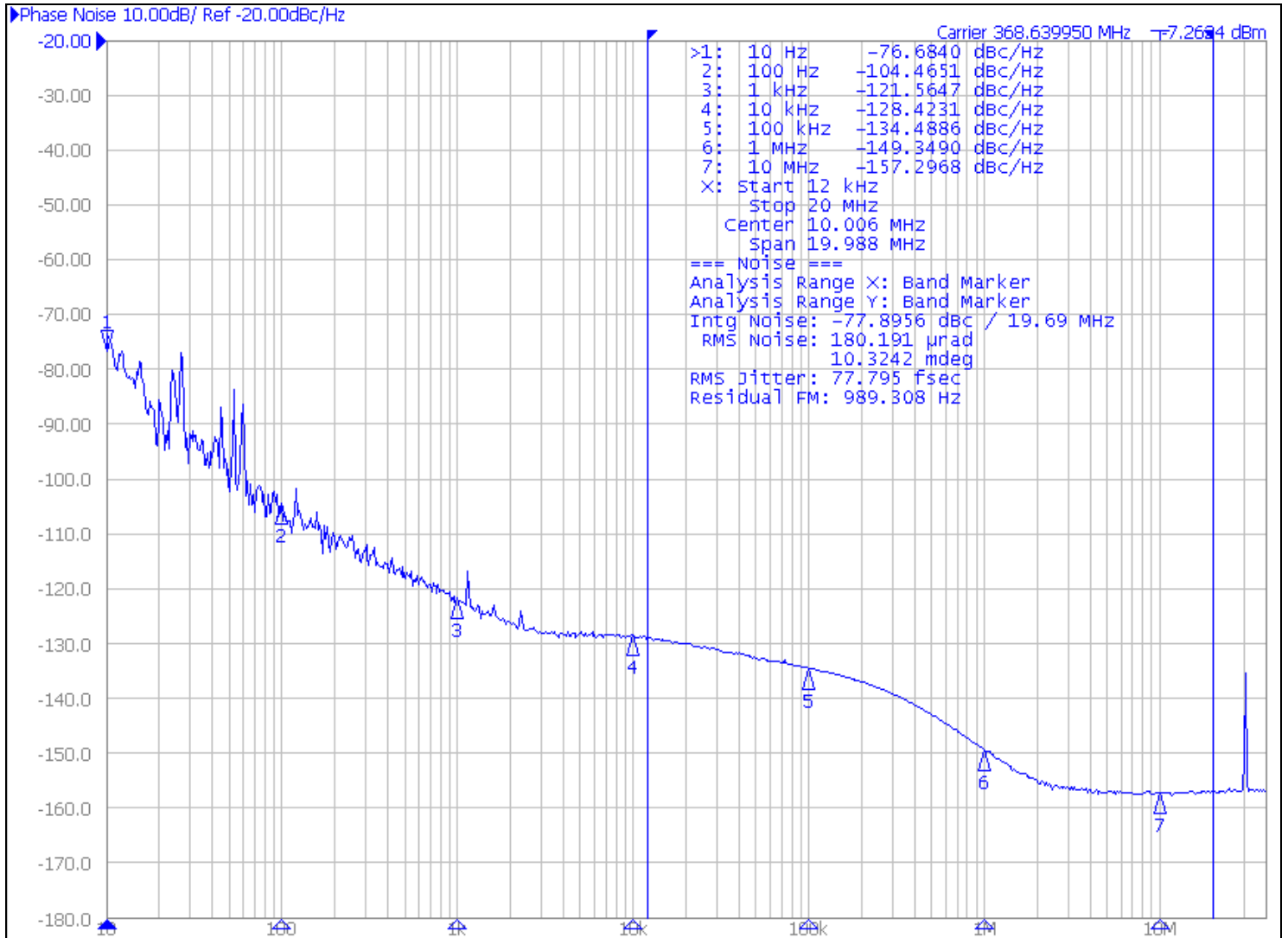

Figure 14. 245.76MHz Output Phase Noise

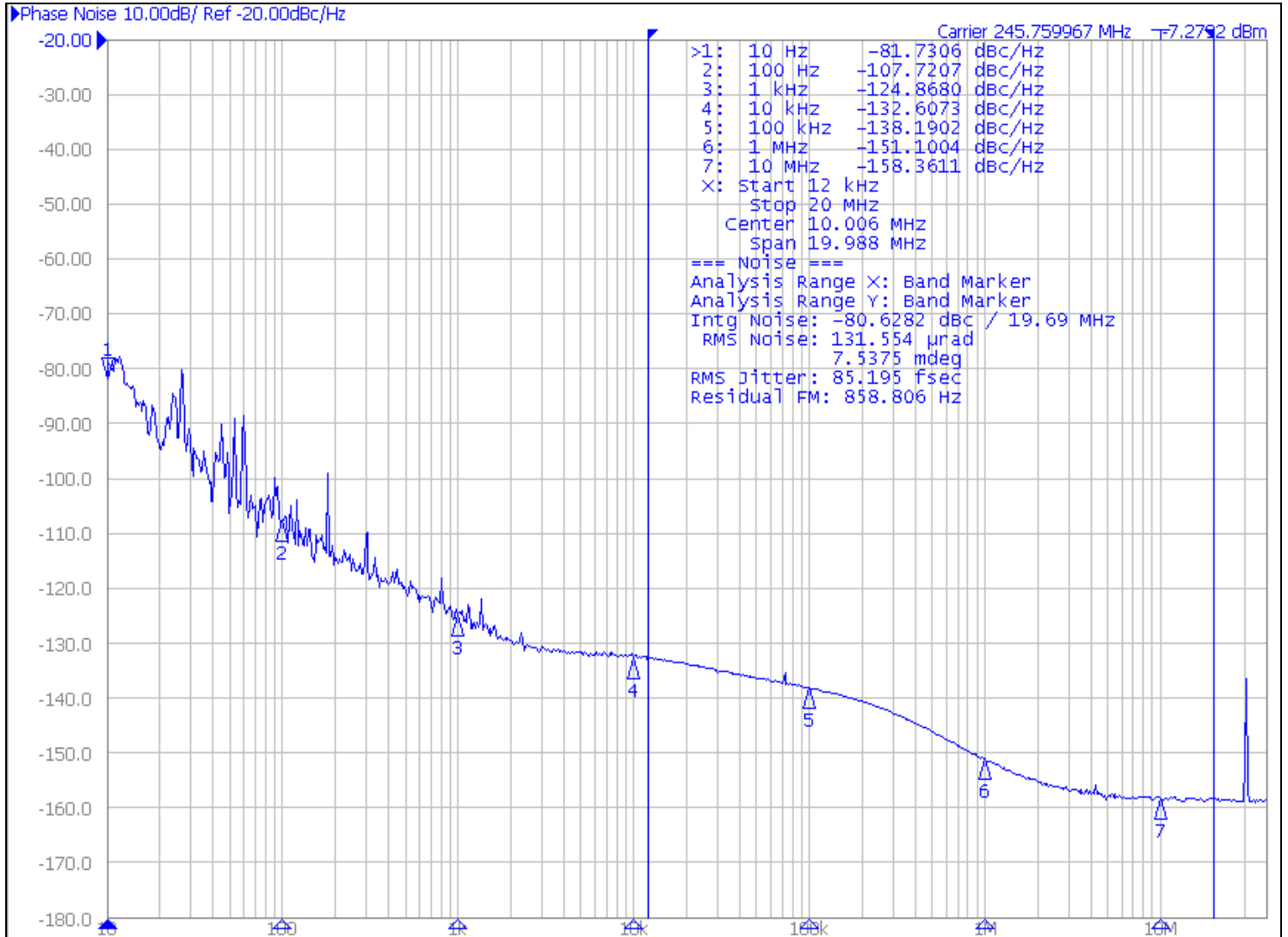

Figure 15. 122.88MHz Output Phase Noise

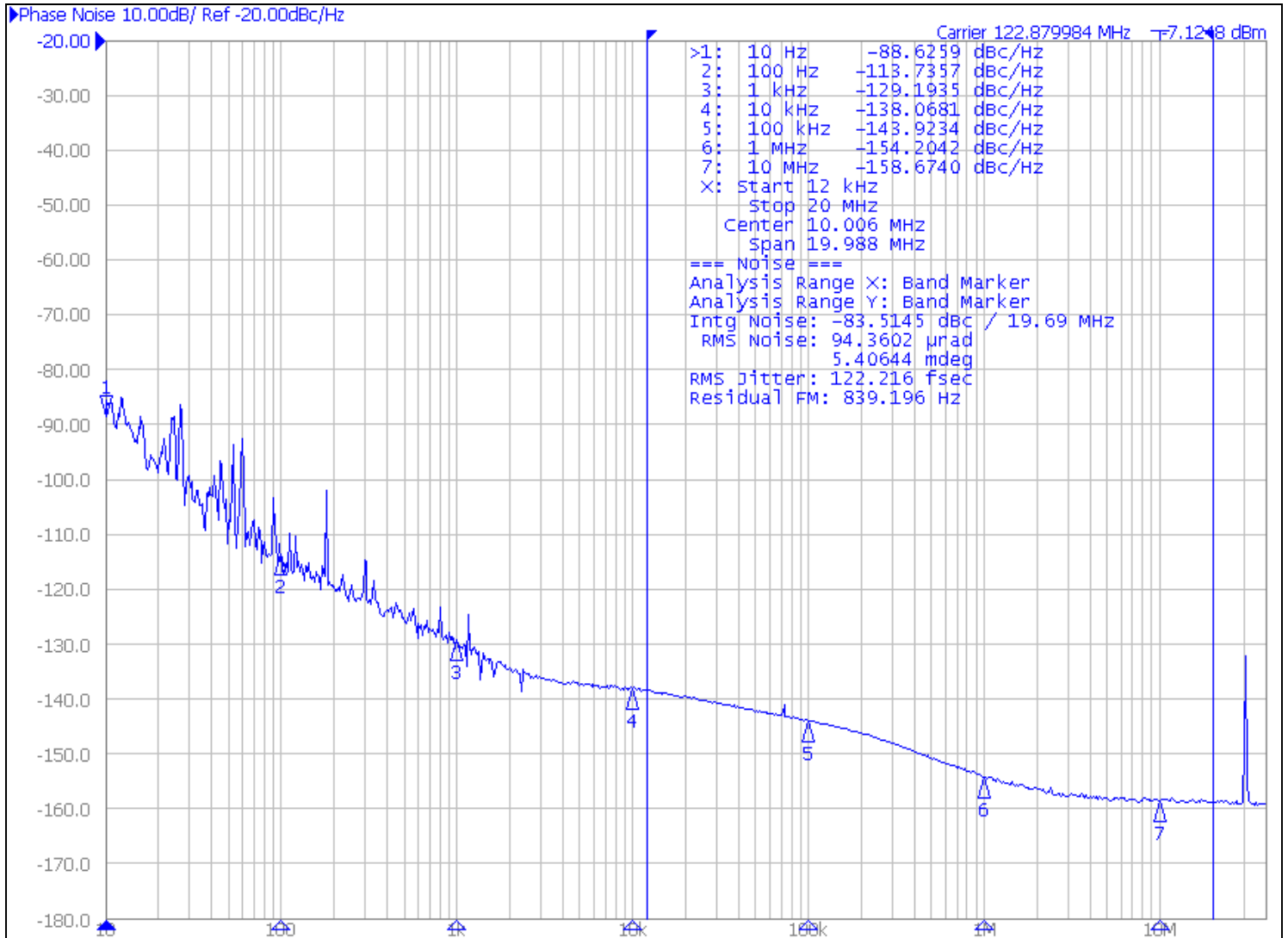

Table 55. Clock Phase Noise Characteristics ( $f_{VCXO} = 122.88\text{MHz}$ ),  $V_{DD\_V} = 3.3\text{V} \pm 5\%$ ,  $V_{DDO\_V} = (3.3\text{V}, 2.5\text{V}, \text{or } 1.8\text{V}) \pm 5\%$ ,  $T_A = -40^\circ\text{C to } +85^\circ\text{C}$  [a] [b]

Symbol	Parameter		Test Conditions	Minimum	Typical	Maximum	Units
$j_{it}(\emptyset)$	Clock RMS Phase Jitter (Random)		Integration Range: 1kHz – 76.8MHz		90	150	fs
			Integration Range: 12kHz – 20MHz		104	139	fs
$\Phi_N(10)$	Clock Single-side Band Phase Noise (integer divider)	1474.56MHz	10Hz offset (determined by VCXO)		-59.9		dBc/Hz
$\Phi_N(100)$			100Hz offset (determined by VCXO)		-87.6		dBc/Hz
$\Phi_N(1k)$			1kHz offset from carrier		-111	-105	dBc/Hz
$\Phi_N(10k)$			10kHz offset from carrier		-123.2	-112	dBc/Hz
$\Phi_N(100k)$			100kHz offset from carrier		-127.7	-118	dBc/Hz
$\Phi_N(1M)$			1MHz offset from carrier		-138.7	-135	dBc/Hz
$\Phi_N(\geq 10M)$			$\geq 10\text{MHz}$ offset from carrier and Noise Floor		-152.8	-147	dBc/Hz
$\Phi_N(10)$	Clock Single-side Band Phase Noise (integer divider)	983.04MHz	10Hz offset (determined by VCXO)		-64.1		dBc/Hz
$\Phi_N(100)$			100Hz offset (determined by VCXO)		-93.6		dBc/Hz
$\Phi_N(1k)$			1kHz offset from carrier		-114.3	-105	dBc/Hz
$\Phi_N(10k)$			10kHz offset from carrier		-125.4	-115	dBc/Hz
$\Phi_N(100k)$			100kHz offset from carrier		-130.1	-120	dBc/Hz
$\Phi_N(1M)$			1MHz offset from carrier		-141.4	-135	dBc/Hz
$\Phi_N(\geq 10M)$			$\geq 10\text{MHz}$ offset from carrier and Noise Floor		-153.8	-150	dBc/Hz
$\Phi_N(10)$	Clock Single-side Band Phase Noise (integer divider)	737.28MHz	10Hz offset (determined by VCXO)		-67.5		dBc/Hz
$\Phi_N(100)$			100Hz offset (determined by VCXO)		-93.9		dBc/Hz
$\Phi_N(1k)$			1kHz offset from carrier		-117.7	-110	dBc/Hz
$\Phi_N(10k)$			10kHz offset from carrier		128.7	-118	dBc/Hz
$\Phi_N(100k)$			100kHz offset from carrier		133.5	-123	dBc/Hz
$\Phi_N(1M)$			1MHz offset from carrier		-144.4	-138	dBc/Hz
$\Phi_N(\geq 10M)$			$\geq 10\text{MHz}$ offset from carrier and Noise Floor		-155.8	-150	dBc/Hz
$\Phi_N(10)$	Clock Single-side Band Phase Noise (integer divider)	491.52MHz	10Hz offset (determined by VCXO)		-71		dBc/Hz
$\Phi_N(100)$			100Hz offset (determined by VCXO)		-101.1		dBc/Hz
$\Phi_N(1k)$			1kHz offset from carrier		-119.9	-110	dBc/Hz
$\Phi_N(10k)$			10kHz offset from carrier		-132.2	-120	dBc/Hz
$\Phi_N(100k)$			100kHz offset from carrier		-137	-125	dBc/Hz
$\Phi_N(1M)$			1MHz offset from carrier		-146.5	-142	dBc/Hz
$\Phi_N(\geq 10M)$			$\geq 10\text{MHz}$ offset from carrier and Noise Floor		-157.2	-150	dBc/Hz

Table 55. Clock Phase Noise Characteristics ( $f_{VCXO} = 122.88\text{MHz}$ ),  $V_{DD\_V} = 3.3\text{V} \pm 5\%$ ,  $V_{DDO\_V} = (3.3\text{V}, 2.5\text{V}, \text{or } 1.8\text{V}) \pm 5\%$ ,  $T_A = -40^\circ\text{C to } +85^\circ\text{C}$  [a] [b] (Cont.)

Symbol	Parameter		Test Conditions	Minimum	Typical	Maximum	Units
$\Phi_N(10)$	Clock Single-side Band Phase Noise (integer divider)	368.64MHz	10Hz offset (determined by VCXO)		-64.6		dBc/Hz
$\Phi_N(100)$			100Hz offset (determined by VCXO)		-100.6		dBc/Hz
$\Phi_N(1k)$			1kHz offset from carrier		-122.9	-113	dBc/Hz
$\Phi_N(10k)$			10kHz offset from carrier		-134.4	-123	dBc/Hz
$\Phi_N(100k)$			100kHz offset from carrier		-139.4	-128	dBc/Hz
$\Phi_N(1M)$			1MHz offset from carrier		-150	-146	dBc/Hz
$\Phi_N(\geq 10M)$			$\geq 10\text{MHz}$ offset from carrier and noise Floor		-158.1	-153	dBc/Hz
$\Phi_N(10)$	Clock Single-side Band Phase Noise (integer divider)	245.76MHz	10Hz offset (determined by VCXO)		-71.7		dBc/Hz
$\Phi_N(100)$			100Hz offset (determined by VCXO)		-105.5		dBc/Hz
$\Phi_N(1k)$			1kHz offset from carrier		-128.3	-115	dBc/Hz
$\Phi_N(10k)$			10kHz offset from carrier		-138	-130	dBc/Hz
$\Phi_N(100k)$			100kHz offset from carrier		-142.7	-135	dBc/Hz
$\Phi_N(1M)$			1MHz offset from carrier		-153.2	-148	dBc/Hz
$\Phi_N(\geq 10M)$			$\geq 10\text{MHz}$ offset from Carrier and noise Floor		-160.5	-155	dBc/Hz
$\Phi_N(10)$	Clock Single-side Band Phase Noise (integer divider)	122.88MHz	10Hz offset (determined by VCXO)		-83.3		dBc/Hz
$\Phi_N(100)$			100Hz offset (determined by VCXO)		-114.3		dBc/Hz
$\Phi_N(1k)$			1kHz offset from carrier		-132.3	-120	dBc/Hz
$\Phi_N(10k)$			10kHz offset from carrier		-144.6	-130	dBc/Hz
$\Phi_N(100k)$			100kHz offset from carrier		-149.3	-135	dBc/Hz
$\Phi_N(1M)$			1MHz offset from carrier		-158.1	-150	dBc/Hz
$\Phi_N(\geq 10M)$			$\geq 10\text{MHz}$ offset from carrier and noise Floor		-161.5	-155	dBc/Hz

[a] Electrical parameters are guaranteed over the specified ambient operating temperature range, which is established when the device is mounted in a test socket with maintained transverse airflow greater than 500 lpm. The device will meet specifications after thermal equilibrium has been reached under these conditions.

[b] Phase noise specifications are applicable for all outputs active,  $N_x$  not equal. Measured using a VCXO with the following characteristics: 122.88MHz, phase noise -145dBc/Hz at 1kHz, -155dBc/Hz at 10kHz offset, -160dBc/Hz at 100kHz offset

Table 56. 8V19N470 AC Characteristics: Typical QCLK\_y Output Amplitude,  $V_{DD_V} = 3.3V$ ,  $T_A = 85^\circ C$ <sup>[a]</sup>

Symbol	Parameter	Test Conditions	QCLK_y Output Frequency in MHz						Units
			1474.57	1228.8	983.04	737.28	491.52	245.76	
$V_{O(PP)}$ <sup>[b]</sup>	LVPECL Output Voltage Swing, Peak-to-peak	350mV Amplitude Setting	768	715	745	706	736	723	mV
		500mV Amplitude Setting	1027	996	1003	968	1000	994	mV
		700mV Amplitude Setting	1427	1342	1397	1321	1378	1355	mV
		850mV Amplitude Setting	1694	1617	1675	1587	1651	1626	mV
$V_{OD}$ <sup>[c]</sup>	LVDS Output Voltage Swing, Peak-to-peak	350mV Amplitude Setting	550	581	604	612	627	645	mV
		500mV Amplitude Setting	781	819	851	870	892	909	mV
		700mV Amplitude Setting	1142	1201	1251	1240	1274	1282	mV
		850mV Amplitude Setting	1415	1487	1550	1521	1563	1566	mV

[a] Electrical parameters are guaranteed over the specified ambient operating temperature range, which is established when the device is mounted in a test socket with maintained transverse airflow greater than 500 lpm. The device will meet specifications after thermal equilibrium has been reached under these conditions.

[b] LVPECL outputs terminated  $50\Omega$  to  $V_{TT}$ . For  $V_{TT}$  (Termination voltage) values (see [Table 60](#)).

[c] LVDS outputs terminated  $100\Omega$  across terminals

## Thermal Characteristics

Table 57. Thermal Resistance for 81-FPBGA Package<sup>[a]</sup>

Multi-Layer PCB, JEDEC Standard Test Board				
Symbol	Thermal Parameter	Condition	Value	Unit
$\Theta_{JA}$	Junction-to-ambient	0 m/s air flow	33.4	°C/W
		2 m/s air flow	28.7	°C/W
$\Theta_{JC}$	Junction-to-case		17.8	°C/W
$\Theta_{JB}$	Junction-to-board <sup>[b]</sup>		9.8	°C/W

[a] Standard JEDEC 2S2P multilayer PCB.

[b] Thermal model where the heat dissipated in the component is conducted through the board.  $T_B$  is measured on or near the component lead.

## Temperature Considerations

The device supports applications in a natural convection environment as long as the junction temperature does not exceed the specified junction temperature  $T_J$ . In applications where the heat dissipates through the PCB,  $\Psi_{JB}$  is the correct metric to calculate the junction temperature. The following calculation uses the junction-to-board thermal characterization parameter  $\Psi_{JB}$  to calculate the junction temperature ( $T_J$ ). Care must be taken to not exceed the maximum allowed junction temperature  $T_J$  of 130 °C.

The junction temperature  $T_J$  is calculated using the following equation:  $T_J = T_B + P_{TOT} \times \theta_{JB}$

where:

- $T_J$  is the junction temperature at steady state conditions in °C.
- $T_B$  is the board temperature at steady state condition in °C, measured on or near the component lead.
- $\Theta_{JB}$  is the thermal characterization parameter to report the difference between  $T_J$  and  $T_B$ .
- $P_{TOT}$  is the total device power dissipation.

**Application power dissipation scenarios:** Applications may use device settings that result in a lower power dissipation than the maximum power scenario. The device is a multi-functional, high-speed device that targets a variety of applications. Since this device is highly programmable with a broad range of settings and configurations, the power consumption will vary as settings and configurations are changed. [Table 58](#) shows the typical current consumption and total device power consumption along with the junction temperature for the test cases shown in [Table 48](#) and [Table 49](#). The table also displays the maximum board temperature for the  $\Theta_{JB}$  model.

**Reducing power consumption:** The output state (on/off) and the output amplitude have the largest impact on the device power consumption and the junction temperature: setting the output amplitude to lower voltages and supplying the outputs by 1.8V reduces power consumption. Unused and periodically unused outputs and inputs should be turned off in phases of inactivity to reduce power. For any given divider setting, the clock frequency has no impact on the device power consumption of the device.

Table 58. Typical Device Power Dissipation and Junction Temperature for LVDS Output Configurations

Test Case <sup>[a]</sup>	Output Configuration	Device			$\Theta_{JB}$ Thermal Model	
		$I_{DD\_V}$	$I_{DDO\_V}$	$P_{TOT}$	$T_J$ <sup>[b]</sup>	$T_{B,MAX}$ <sup>[c]</sup>
		mA	mA	W	°C	°C
1	QCLK: LVDS, 350mV, VDDO = 3.3V	325	111	1.439	99.1	115.9
2	QCLK: LVDS, 500mV, VDDO = 3.3V	325	161	1.604	100.7	114.3
3	QCLK: LVDS, 700mV, VDDO = 3.3V	325	203	1.742	102.1	112.9
4	QCLK: LVDS, 850mV, VDDO = 3.3V	325	252	1.904	103.7	111.3
5	QCLK: LVDS, 350mV, VDDO = 1.8V	325	103	1.258	97.3	117.7
6	QCLK: LVDS, 500mV, VDDO = 1.8V	325	147	1.337	98.1	116.9

[a] For device settings (see Table 58).

[b] Junction temperature at board temperature  $T_B = 85^\circ\text{C}$ .

[c] Maximum board temperature for junction temperature  $< 130^\circ\text{C}$ :  $T_{B,MAX} = T_{J,MAX} - \Theta_{JB} \times P_{TOT}$ .

Table 59. Typical Device Power Dissipation and Junction Temperature for LVPECL Output Configurations

Test Case <sup>[a]</sup>	Output Configuration	Device			$\Theta_{JB}$ Thermal Model	
		$I_{DD\_V}$	$I_{DDO\_V}$	$P_{TOT}$	$T_J$ <sup>[b]</sup>	$T_{B,MAX}$ <sup>[c]</sup>
		mA	mA	W	°C	°C
1	QCLK: LVPECL, 350mV, VDDO = 3.3V	325	246	1.340	98.1	116.9
2	QCLK: LVPECL, 500mV, VDDO = 3.3V	325	276	1.390	98.6	116.4
3	QCLK: LVPECL, 700mV, VDDO = 3.3V	326	317	1.470	99.4	115.6
4	QCLK: LVPECL, 850mV, VDDO = 3.3V	329	348	1.540	100.1	114.9
5	QCLK: LVPECL, 350mV, VDDO = 1.8V	334	244	1.350	98.2	116.8
6	QCLK: LVPECL, 500mV, VDDO = 1.8V	335	274	1.390	98.6	116.4

[a] For device settings (see Table 59).

[b] Junction temperature at board temperature  $T_B = 85^\circ\text{C}$ .

[c] Maximum board temperature for junction temperature  $< 130^\circ\text{C}$ :  $T_{B,MAX} = T_{J,MAX} - \Theta_{JB} \times P_{TOT}$ .

## Applications Information

### VCXO-PLL Loop Filter

Each of the two PLLs uses a loop filter with external components. The value of the external components depend on the desired loop bandwidth for each PLL, the input clock frequency and in the case of the VCXO-PLL, on the external VCXO component. For the VCXO-PLL (first PLL stage), a 2nd or 3rd order loop filter may be used. The loop filter of the VCXO-PLL is connected to the device through the LFV charge pump input. The filter output is connected to the control voltage input of the external VCXO. The FemtoClock NG PLL (second PLL stage) may use a 2nd order loop filter. The LFF output of the device connects to filter input and LFFR to the filter output.

Typical loop filters are shown in [Figure 16](#) (2nd order) in [Figure 17](#) (3rd order) and are discussed below. Step by step calculations to determine the value of the loop filter components values are shown.

#### Second-Order Loop Filter

Figure 16. Second-Order Loop Filter

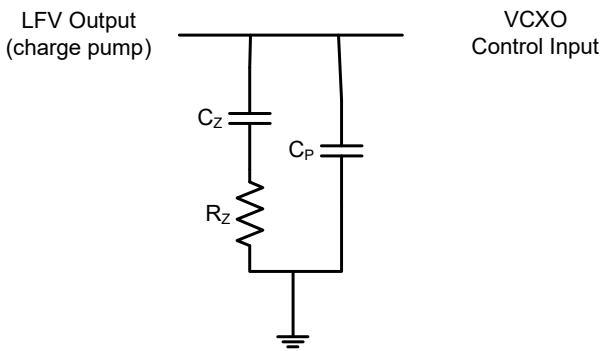

#### Step-by-step calculation:

Step 1: Determine the desired loop bandwidth  $f_C$ .  $f_C$  must satisfy the following condition:

$$\frac{f_{PD}}{f_C} \gg 20$$

Where  $f_{PD}$  is the input frequency of the VCXO-PLL phase detector frequency.

Step 2: Calculate  $R_Z$  by:

$$R_Z = \frac{2\pi \times f_C M_V}{I_{CP} \times K_{VCXO}}$$

Where  $I_{CP}$  is the VCXO-PLL charge pump current and  $K_{VCXO}$  is the gain of the VCXO component (consult the datasheet of the external VCXO for its gain parameter).  $M_V$  is the effective feedback divider:

$$M_V = \frac{f_{VCXO}}{f_{PD}}$$

$f_{VCXO}$  is the frequency of the external VCXO component.

Step 3: Calculate  $C_Z$  by:

$$C_Z = \frac{\alpha}{2\pi f_C R_Z}$$

$$\alpha = \frac{f_C}{f_Z}$$

$\alpha$  is ratio between the loop bandwidth and the filter zero.  $f_Z$  is the filter zero.  $\alpha$  should be greater than 3.

Step 4: Calculate  $C_P$  by:

$$C_P = \frac{C_Z}{\alpha\beta}$$

$$\beta = \frac{f_P}{f_C}$$

$f_P$  is the pole and  $\beta$  is ratio between the pole and the loop bandwidth.  $\beta$  should be greater than 3.

Step 4: Verify that the phase margin PM is greater than 50°.

$$PM = \text{atan} \frac{b-1}{2\sqrt{b}}$$

$$b = \frac{C_Z}{C_P} + 1$$

**Example calculation:** The [Block Diagram](#) shows a 2nd order loop filter for the VCXO-PLL. In this example, the VCXO-PLL reference frequency is 122.88MHz and an external VCXO component of 122.88MHz is used. The desired VCXO-PLL loop bandwidth  $f_C$  is 40 Hz. To achieve the desired loop bandwidth with small size loop filter components, set the PLL frequency pre-divider  $P_V$  and the PLL feedback divider  $M_V$  to 1024. According to the step 1 instruction,  $f_{PD}$  is 120kHz. This satisfies the condition  $f_{PD}/f_C \gg 20$ .  $R_Z$  is calculated 32.2k $\Omega$ .

The VCXO gain  $K_{VCXO}$  used for the device reference circuit is 10kHz/V. The charge pump current of the VCXO-PLL is configurable from 50 $\mu$ A to 1200 $\mu$ A. The charge pump current is programmed to  $I_{CP} = 800\mu$ A. For  $\alpha = 8$ ,  $C_Z$  is calculated to be 0.99 $\mu$ F.  $C_Z$  greater than this value assures  $\alpha > 12$ . For example, the actual chosen value is the standard capacitor value of 1 $\mu$ F. For  $\beta = 5$ ,  $C_P$  is calculated 24.7nF. The standard capacitor value of  $C_P = 27$ ps ensures  $\beta > 7$ .

### Third-Order Loop Filter

Figure 17. Third Order Loop Filter

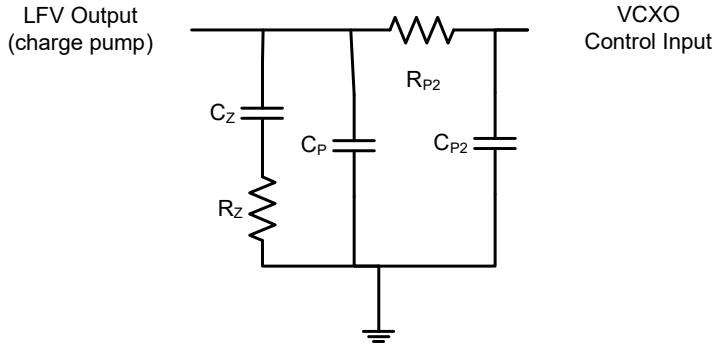

Figure 17 shows a third-order loop filter. The filter is equivalent to the 2nd order filter in Figure 16 with the addition components  $R_{P2}$  and  $C_{P2}$ . The additional components  $R_{P2}$  and  $C_{P2}$  should be calculated as shown:

$$C_{P2} = \frac{C_P \times R_Z}{\gamma \times R_{P2}}$$

$$R_{P2} \sim R_Z \times 1.5$$

$\gamma$  is the ratio between the 1<sup>st</sup> pole and the 2<sup>nd</sup> pole.  $\gamma$  should be greater than 3.

Example calculation for the 3<sup>rd</sup> order loop filter shown in Figure 17: Equivalent to the 2nd order loop filter calculation,  $R_Z = 33k\Omega$ ,  $C_Z = 1\mu F$ , and  $C_P = 27nF$ .  $R_{P2}$  should be in the range of  $0.5 \times R_Z < R_{P2} < 2.5 \times R_Z$ , for instance  $51k\Omega$ . With  $\gamma = 4$ ,  $C_{P2}$  is  $4.37nF$  (select  $4.7\mu F$ ).

### FemtoClock NG PLL Loop Filter

Figure 18 shows a 2nd order loop filter for the FemtoClock NG PLL. This loop filter is equivalent to Figure 16 and uses the loop filter components  $R_{ZF}$  ( $R_Z$ ),  $C_{ZF}$  ( $C_Z$ ) and  $C_{PF}$  ( $C_P$ ). The VCO frequency of the FemtoClock NG PLL is 2949.12MHz.

Figure 18. 2nd Order Loop Filter for the FemtoClock NG PLL

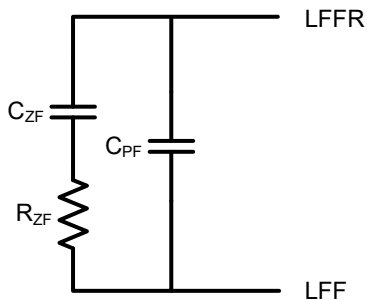

Example calculation for the 2nd order loop filter shown in Figure 18: the FemtoClock NG receives its reference frequency from the VCXO output. With the  $P_F$  pre-divider set to 1, the phase detector frequency is also 122.88MHz. The PLL feedback divider must be set to  $M_F = 24$  in order to locate the VCO frequencies in its center range. A target PLL loop bandwidth  $f_C$  is 80kHz satisfies the condition in step 1. The gain of the internal VCO is 30MHz/V and the charge pump current  $I_{CP}$  is set to 3.6mA. Using the formula for  $R_Z$  in step 2,  $R_{ZF}$  is calculated  $103\Omega$  (chose the standard value of  $100\Omega$ ); using the formula for  $C_Z$  in step 3,  $C_{ZF}$  is calculated  $88nF$  for  $\alpha = 4$ . A capacitor larger than  $88nF$  should be used for  $C_{ZF}$  to assure that the  $\alpha$  is greater than 4, for instance the standard component capacitor value  $100nF$ .

The recommended  $C_{PF}$  value for the loop filter is  $40pF$  (loop filter components are partially integrated). The selected 2nd order loop filter components for this PLL are:  $R_{ZF} = 100\Omega$ ,  $C_{ZF} = 100nF$ , and  $C_{PF} = 40pF$ .

## Output Termination

### LVPECL-style Outputs

Differential outputs configured to LVPECL-style are of open-emitter type and require a termination with a DC current path to GND. This section displays parallel and thevenin termination, Y-termination and source termination for various output supply ( $V_{DDO\_V}$ ) and amplitude settings.  $V_{TT}$  is the termination voltage.

Figure 19. Parallel Termination 1

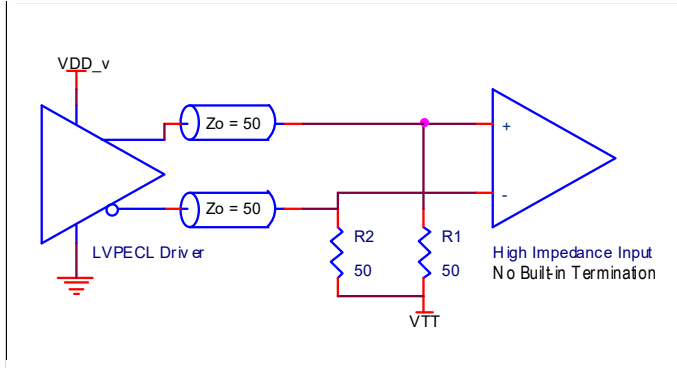

Table 60. Termination Voltage  $V_{TT}$  for Figure 19<sup>[a]</sup>

LVPECL Amplitude (mV)	$V_{TT}$ (V)
350	$V_{DDO\_V} - 1.60$
500	$V_{DDO\_V} - 1.75$
700	$V_{DDO\_V} - 1.95$
850	$V_{DDO\_V} - 2.10$

[a] Output power supplies supporting 3.3V, 2.5V and 1.8V are  $V_{DDO\_QCLKA}$ ,  $V_{DDO\_QCLKB}$ ,  $V_{DDO\_QCLKC}$  and  $V_{DDO\_QCLKD}$ .

Figure 20. Parallel Termination 2

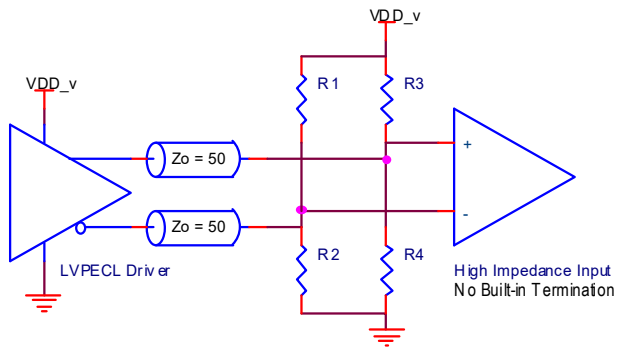

Table 61. Termination Resistor Values for Figure 20

$V_{DDO\_V}$ (V) <sup>[a]</sup>	LVPECL Amplitude (mV)	R1, R3 ( $\Omega$ )	R2, R4 ( $\Omega$ )
3.3	350	97.1	103.1
	500	106.5	94.3
	700	122	84.6
	850	137.5	78.6
2.5	350	138.8	78.1
	500	166.7	71.4
	700	227.3	64.1
	850	312.5	59.5
1.8	350	450	56.3
	500	–	50

[a] Output power supplies supporting 3.3V, 2.5V and 1.8V are VDDO\_QCLKA, VDDO\_QCLKB, VDDO\_QCLKC, and VDDO\_QCLKD.

Figure 21. Y-Termination

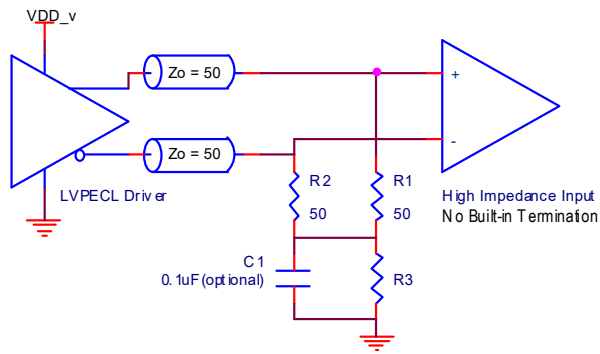

Table 62. Termination Resistor Values for Figure 21

V <sub>DDO_V</sub> (V) <sup>[a]</sup>	LVPECL Amplitude (mV)	R3 (Ω)
3.3	350, 500, 700, 850	50
2.5	350, 500, 700, 850	18
1.8	350, 500	0

[a] Output power supplies supporting 3.3V, 2.5V and 1.8V are VDDO\_QCLKA, VDDO\_QCLKB, VDDO\_QCLKC, and VDDO\_QCLKD.

Figure 22. Source Termination

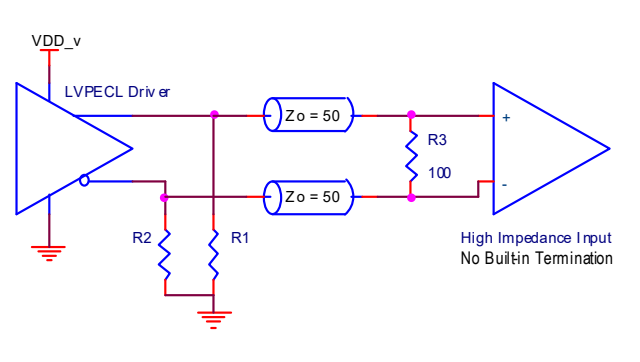

Table 63. Termination Resistor Values for Figure 22

V <sub>DDO_V</sub> (V) <sup>[a]</sup>	LVPECL Amplitude (mV)	R1, R2 (Ω)
3.3	350, 500, 700, 850	100 – 200
2.5	350, 500, 700, 850	80 – 150
1.8	350	50 – 100

[a] Output power supplies supporting 3.3V, 2.5V and 1.8V are VDDO\_QCLKA, VDDO\_QCLKB, VDDO\_QCLKC and VDDO\_QCLKD.

Figure 23. LVDS-Style Outputs (1)

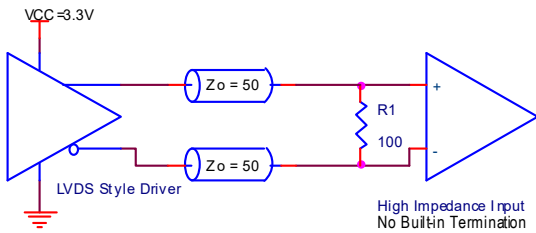
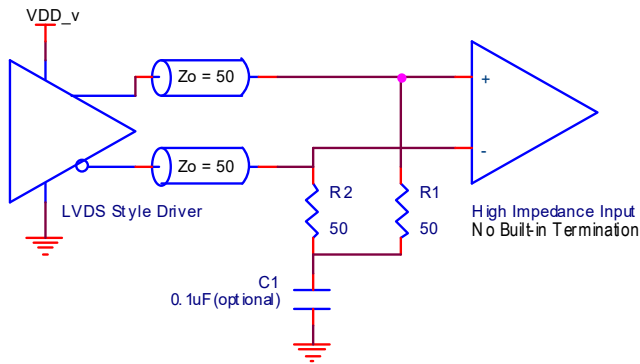

Figure 24. LVDS-Style Outputs (2)



LVDS style outputs support fully differential terminations. LVDS does not require board level pull-down resistors for DC termination. [Figure 23](#) and [Figure 24](#) show typical termination examples with DC coupling for the LVDS style driver. In these examples, the receiver is high input impedance without built-in termination. LVDS-style with a differential termination is preferred for best common-mode rejection and lowest device power consumption.

## Power Supply Filtering

Please refer to the document *8V19N470 Hardware Design Guide* for comprehensive information about power supply and isolation, loop filter design for VCXO and VCO, schematics, input and output interfaces/terminations and an example schematics. This document shows a recommended power supply filter schematic in which the device is operated at  $V_{DD\_V} = 3.3V$  (The output supply voltages of  $V_{DDO\_V} = 3.3V, 2.5V$  and  $1.8V$  are supported). This example focuses on power supply connections and is not configuration specific. Refer to the pin description and functional tables in the datasheet to ensure that the logic control inputs are properly set for the application.

As with any high speed analog circuitry, the power supply pins are vulnerable to board supply or device generated noise. This device requires an external voltage regulator for the  $V_{DD\_V}$  pins for isolation of board supply noise. This regulator (example component: PS7A8300RGT) is indicated in the schematic by the power supply, VREG\_3.3V. Consult the voltage regulator specification for details of the required performance. To achieve optimum jitter performance, power supply isolation is required to minimize device generated noise. The VDD\_LCF terminal requires the cleanest power supply. The device provides separate power supplies to isolate any high switching noise from coupling into the internal PLLs and into other outputs as shown. In order to achieve the best possible filtering, it is recommended that the placement of the filter components be on the device side of the PCB as close to the power pins as possible. If space is limited the  $0.1\mu F$  and  $0.01\mu F$  capacitors in each power pin filter should be placed on the device side. The other components can be on the opposite side of the PCB. Pull-up and pull-down resistors to set configuration pins can all be placed on the PCB side opposite the device side to free up device side area if necessary.

Power supply filter recommendations are a general guideline to be used for reducing external noise from coupling into the devices. The filter performance is designed for a wide range of noise frequencies. This low-pass filter starts to attenuate noise at approximately 10kHz. If a specific frequency noise component is known, such as switching power supplies frequencies, it is recommended that component values be adjusted and if required, additional filtering be added. Additionally, good general design practices for power plane voltage stability suggests adding bulk capacitance in the local area of all devices.

# Package Outline Drawings

Figure 25. Package Outline Drawings - Sheet 1

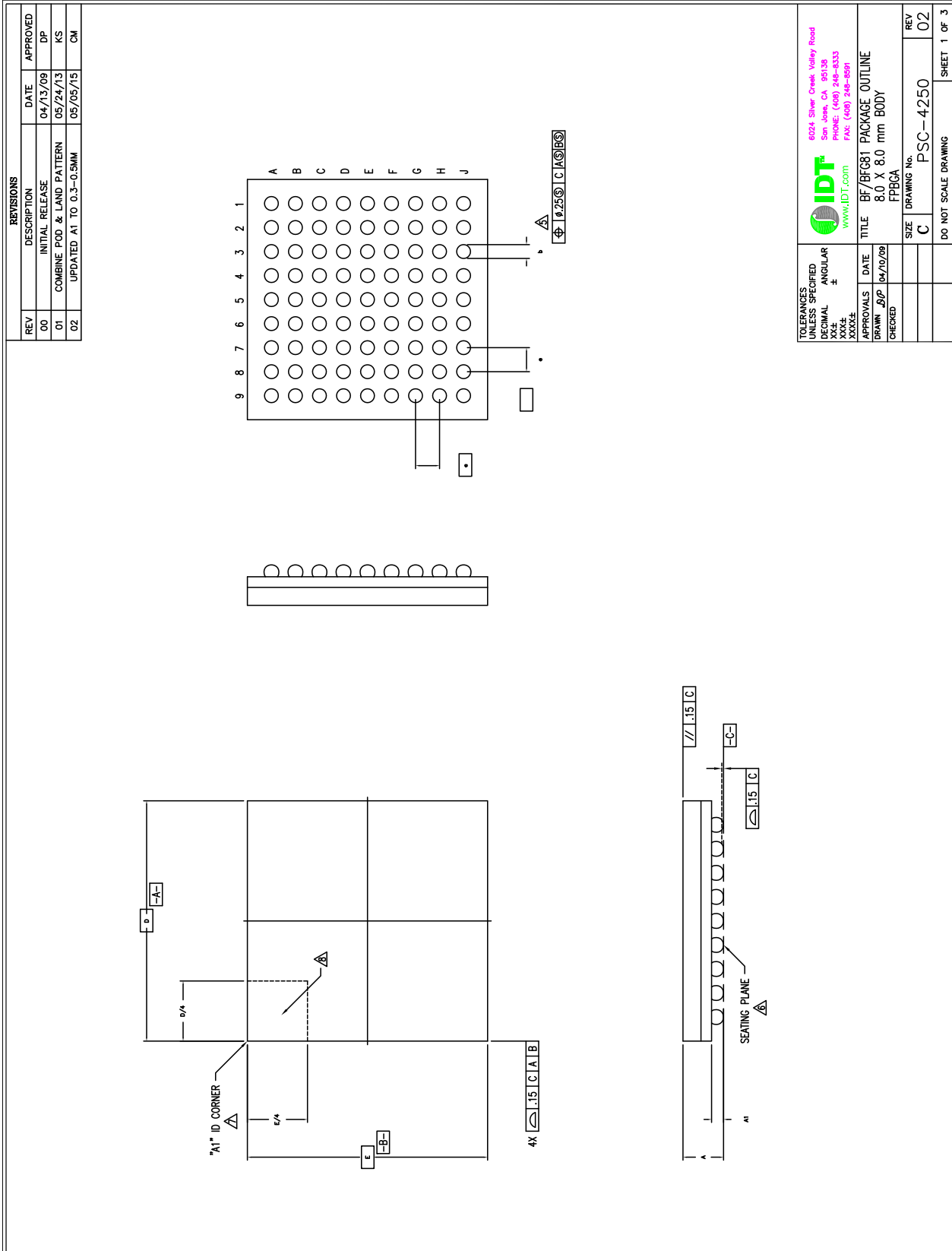

Figure 26. Package Drawings - Sheet 2

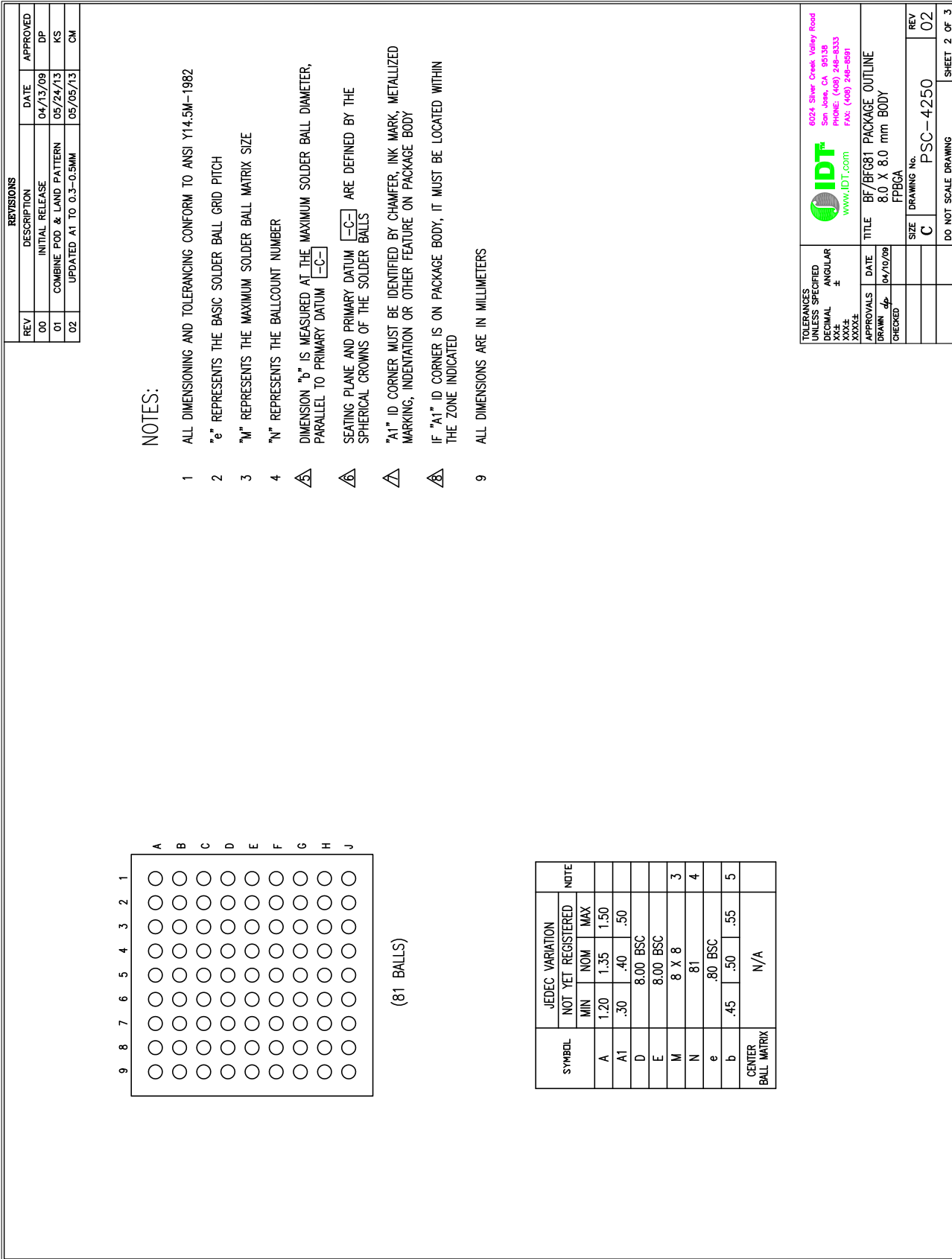
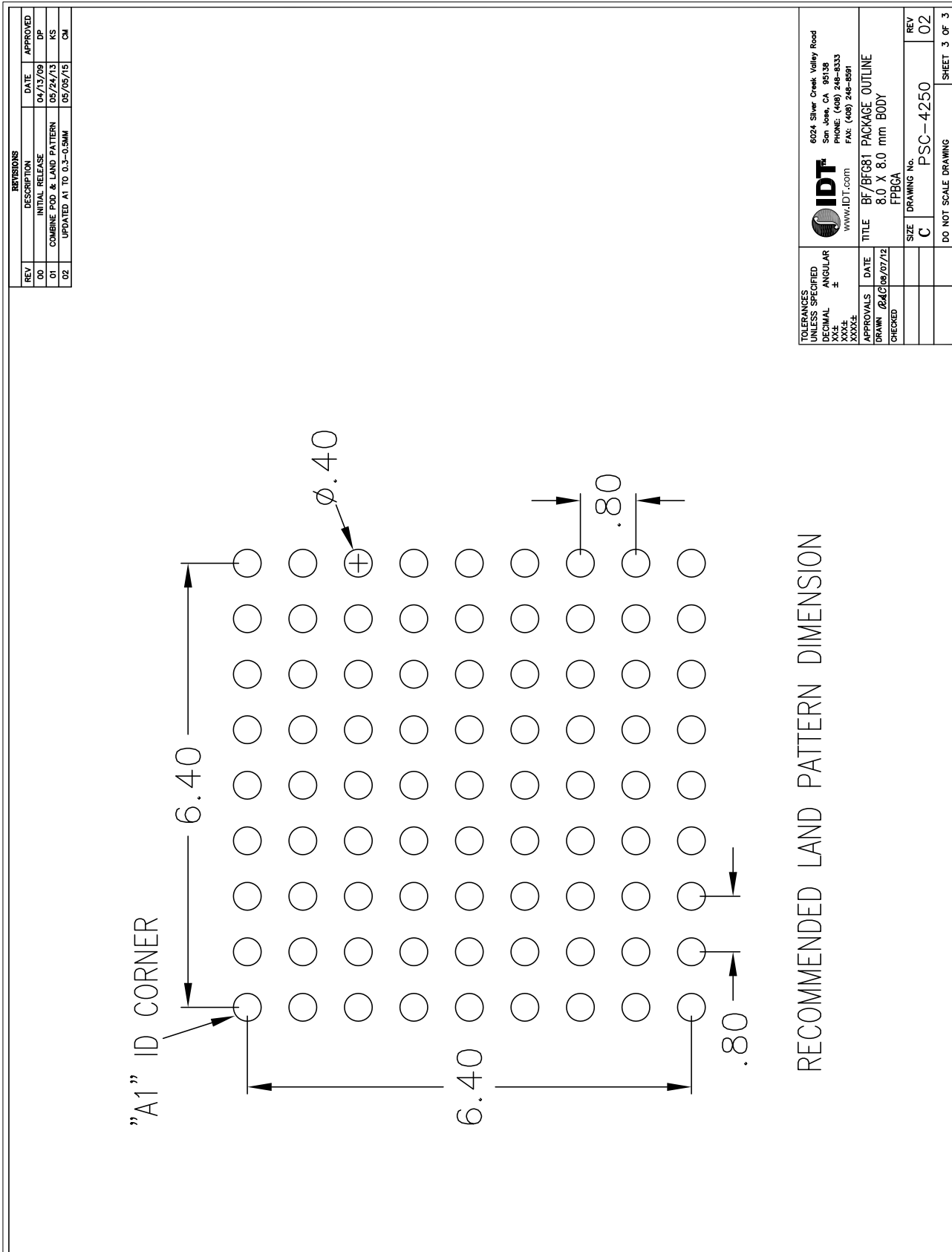

Figure 27. Package Drawings - Sheet 3



## Marking Diagram

Figure 28. Marking Diagram



1. Line 1 indicates the prefix
2. Line 2 indicates the part number.
3. Line 3 indicates the package part number code.
4. Line 4:
  - “YYWW” is the last digit of the year and week that the part was assembled.
  - #: denotes sequential lot number.
  - \$: denotes mark code.

## Ordering Information

Part/Order Number	Marking	Package	Shipping Packaging	Temperature
8V19N470BFGI	IDT8V19N470BFGI	8 × 8 × 1.35 mm, 81-FPBGA	Tray	-40°C to +85°C
8V19N470BFGI8	IDT8V19N470BFGI	8 × 8 × 1.35 mm, 81-FPBGA	Tape and Reel	-40°C to +85°C

## Glossary

Table 64. Glossary

Abbreviation	Description
Index <i>n</i>	Denominates a clock input. Range: 0 to 1.
Index <i>x</i>	Denominates a channel, channel frequency divider and the associated configuration bits. Range: A, B, C, D.
Index <i>y</i>	Denominates a QCLK output and associated configuration bits. Range: A0, A1, A2, B0, B1, B2, C0, C1, D0, D1.
V <sub>DD_V</sub>	Denominates core voltage supply pins. Range: VDD_QCLKA, VDD_QCLKB, VDD_QCLKC, VDD_QCLKD, VDD_QCLKE, VDD_SPI, VDD_INP, VDD_LCV, VDD_LCF, VDD_CPV, VDD_CPF and VDD_OSC.
V <sub>DDO_V</sub>	Denominates output voltage supply pins. Range: VDDO_QCLKA, VDDO_QCLKB, VDDO_QCLKC, and VDDO_QCLKD.
status_condition	Status conditions are: LOLV (Loss of VCXO-PLL lock), LOLF (Loss of FemtoClock NG PLL lock) and LOS (Loss of input signal).
[...]	Index brackets describe a group associated with a logical function or a bank of outputs.
{...}	List of discrete values.
Suffix V	Denominates a function associated with the VCXO-PLL.
Suffix F	Denominates a function associated with the 2nd stage PLL (FemtoClock NG).

## Revision History

Revision Date	Description of Change
November 20, 2017	Initial release.

## IMPORTANT NOTICE AND DISCLAIMER

RENESAS ELECTRONICS CORPORATION AND ITS SUBSIDIARIES (“RENESAS”) PROVIDES TECHNICAL SPECIFICATIONS AND RELIABILITY DATA (INCLUDING DATASHEETS), DESIGN RESOURCES (INCLUDING REFERENCE DESIGNS), APPLICATION OR OTHER DESIGN ADVICE, WEB TOOLS, SAFETY INFORMATION, AND OTHER RESOURCES “AS IS” AND WITH ALL FAULTS, AND DISCLAIMS ALL WARRANTIES, EXPRESS OR IMPLIED, INCLUDING, WITHOUT LIMITATION, ANY IMPLIED WARRANTIES OF MERCHANTABILITY, FITNESS FOR A PARTICULAR PURPOSE, OR NON-INFRINGEMENT OF THIRD-PARTY INTELLECTUAL PROPERTY RIGHTS.

These resources are intended for developers who are designing with Renesas products. You are solely responsible for (1) selecting the appropriate products for your application, (2) designing, validating, and testing your application, and (3) ensuring your application meets applicable standards, and any other safety, security, or other requirements. These resources are subject to change without notice. Renesas grants you permission to use these resources only to develop an application that uses Renesas products. Other reproduction or use of these resources is strictly prohibited. No license is granted to any other Renesas intellectual property or to any third-party intellectual property. Renesas disclaims responsibility for, and you will fully indemnify Renesas and its representatives against, any claims, damages, costs, losses, or liabilities arising from your use of these resources. Renesas' products are provided only subject to Renesas' Terms and Conditions of Sale or other applicable terms agreed to in writing. No use of any Renesas resources expands or otherwise alters any applicable warranties or warranty disclaimers for these products.

(Disclaimer Rev.1.01 Jan 2024)

### Corporate Headquarters

TOYOSU FORESIA, 3-2-24 Toyosu,  
Koto-ku, Tokyo 135-0061, Japan  
[www.renesas.com](http://www.renesas.com)

### Trademarks



Renesas and the Renesas logo are trademarks of Renesas Electronics Corporation. All trademarks and registered trademarks are the property of their respective owners.

### Contact Information

For further information on a product, technology, the most up-to-date version of a document, or your nearest sales office, please visit [www.renesas.com/contact-us/](http://www.renesas.com/contact-us/).

## Looking for pricing, stock, or lifecycle information?

Click below to explore more details on WIN SOURCE:

-  [View 8V19N470BFGI on WIN SOURCE](#)
-  [Renesas Electronics America](#) Information

## Optimize Your Supply Chain with WIN SOURCE Solutions

-  Global Sourcing Solution
-  Obsolete Management
-  Cost Control Management
-  Shortage Management
-  Alternative Solution
-  Excess Inventory Management