



**THE DATASHEET OF  
8V41NS0412NLGI**



## Description

The 8V41NS0412 is a clock generator with four output dividers: three integer, and one that is either integer or fractional. When used with an external crystal, the 8V41NS0412 generates high performance timing geared towards the communications and datacom markets, especially for applications demanding extremely low phase noise, such as 10GE, 40GE, 100G, and 400GE.

The 8V41NS0412's versatile frequency configurations are optimized to deliver excellent phase noise performance. The device delivers an optimum combination of high clock frequency and low-phase noise performance, combined with high-power supply noise rejection.

The 8V41NS0412 supports HCSL type of output level on eleven of its outputs. In addition, there is a single LVCMOS output that has the option of providing a generated clock or acting as a reference bypass output.

The device can be configured to deliver specific configurations under pin control only, or additional configurations through an I<sup>2</sup>C serial interface by an external processor.

The 8V41NS0412 is offered in a lead-free (RoHS6) 64-VFQFN package.

## Typical Applications

- PCI Express Clocking
- 10G/40G/100G/400G Ethernet
- Gb Ethernet, Terabit IP switches / routers
- CPRI Interfaces
- Fiber Optics

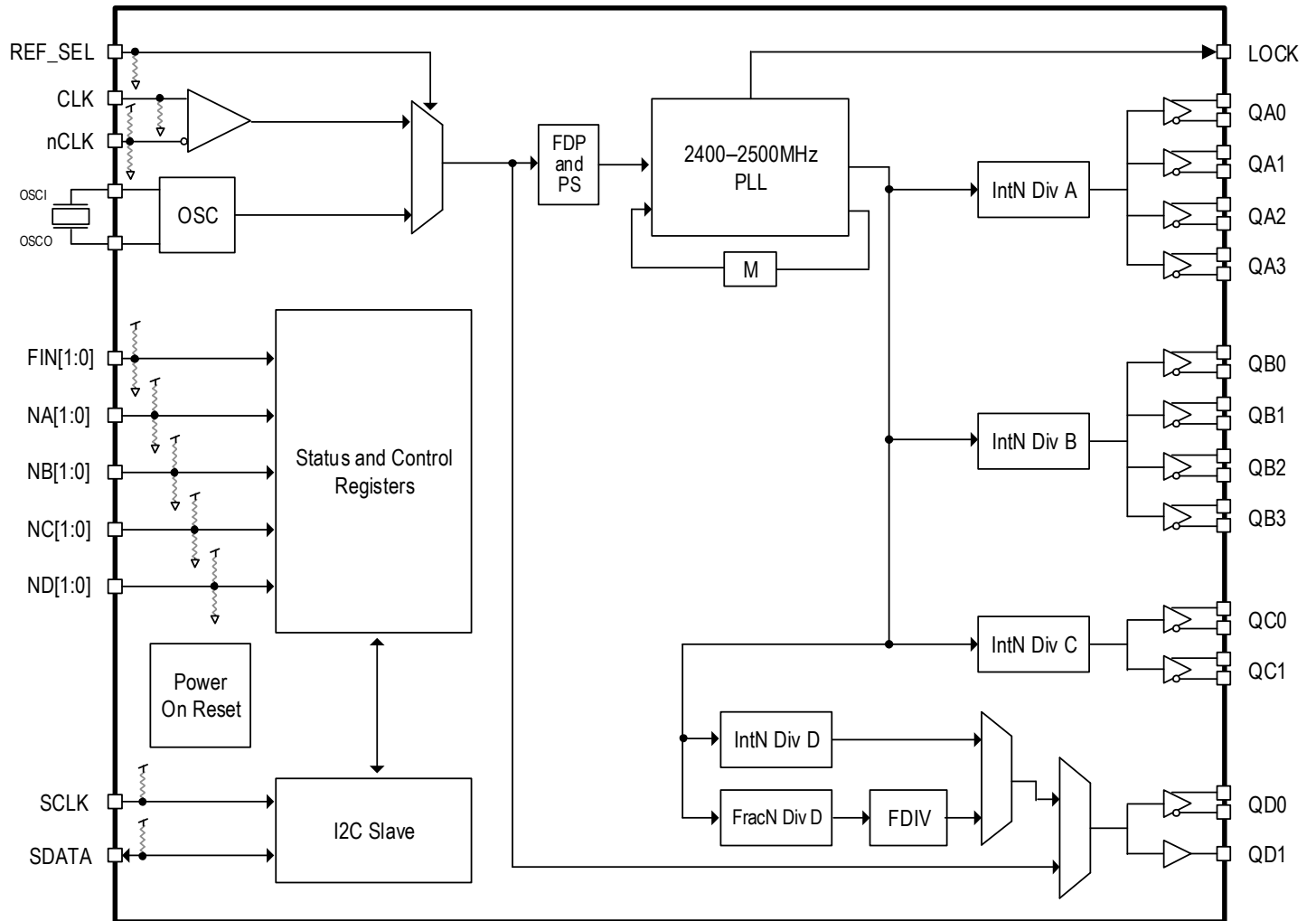
## Features

- Eleven differential HCSL outputs
- One LVCMOS output; input reference can be bypassed to this output
- The clock input operates in full differential mode (LVDS, LVPECL) or single-ended LVCMOS mode
- Driven from a crystal or differential clock input
- A 2.4–2.5GHz PLL frequency range supports Ethernet, SONET, and CPRI frequency plans
- 1.25GHz maximum output frequency
- Four integer output dividers with a range of output divide ratios (see [Table 5](#))
- One fractional output divider can generate any desired output frequency
- Support of output power-down
- Excellent clock output phase noise
 

<u>Offset Output</u>	<u>Frequency</u>	<u>Single-side Band Phase Noise</u>
100kHz	156.25MHz	-143dBc/Hz
- Phase noise RMS, 156.25MHz, 12kHz to 20MHz integration range: 80fs (typical)
- Selected configurations can be controlled via the use of control input pins without need for serial port access
- LVCMOS compatible I<sup>2</sup>C serial interface gives access to additional configurations by external processor or in combination with the control input pins
- Single 3.3V supply voltage
- Lead-free (RoHS 6) 64-VFQFN packaging
- -40°C to 85°C ambient operating temperature

# Block Diagram

Figure 1. 8V41NS0412 Block Diagram



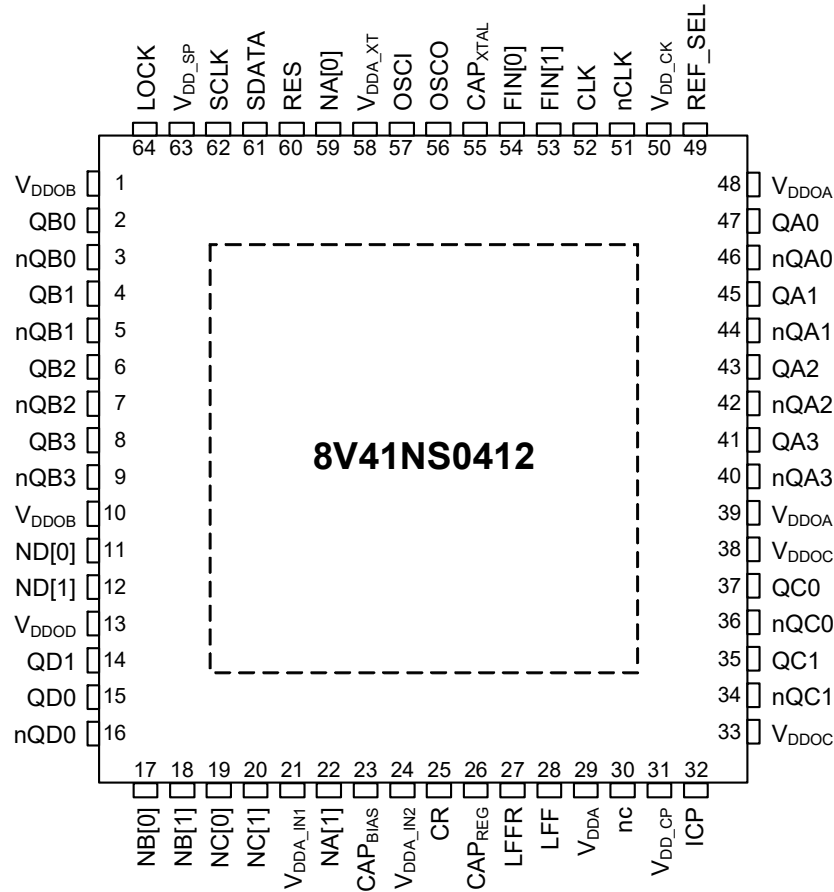
8V41NS0412 transistor count: 131,496

# Contents

Description .....	1
Typical Applications .....	1
Features .....	1
Pin Description .....	4
Principles of Operation .....	7
Pin versus Register Control .....	7
Input Clock Selection (REF_SEL) .....	8
Prescaler and PLL Configuration .....	8
PLL Loop Bandwidth .....	9
Output Divider Frequency Sources .....	9
Integer Output Dividers (Banks A, B, C, and D) .....	10
Fractional Output Divider (Bank D) .....	11
Output Drivers .....	11
Pin Control of the Output Frequencies and Protocols .....	11
Device Start-up and Reset Behavior .....	13
Serial Control Port Description .....	13
Serial Control Port Configuration Description .....	13
I2C Mode Operation .....	13
Recommendations for Unused Input and Output Pins .....	35
Inputs .....	35
Outputs .....	35
Overdriving the XTAL Interface .....	35
Wiring the Differential Input to Accept Single-Ended Levels .....	36
3.3V Differential Clock Input Interface .....	37
Recommended Termination .....	38
VFQFN EPAD Thermal Release Path .....	39
PCI Express Application Note .....	40
Schematic and Layout Recommendations .....	42
Power Dissipation and Thermal Considerations .....	44
Example of Junction Temperature Calculation .....	45
Marking Diagram .....	47
Revision History .....	47

## Pin Assignment

Figure 2. Pin Assignments for 9mm × 9mm 64-VFQFN Package – Top View



## Pin Description

Table 1. Pin Descriptions<sup>[a]</sup>

Number	Name	Type	Description
1	V <sub>DDOB</sub>	Power	Power supply voltage for output Bank B (3.3V).
2	QB0	Output	Differential clock output pair. HCSL interface levels.
3	nQB0	Output	
4	QB1	Output	Differential clock output pair. HCSL interface levels.
5	nQB1	Output	
6	QB2	Output	Differential clock output pair. HCSL interface levels.
7	nQB2	Output	
8	QB3	Output	Differential clock output pair. HCSL interface levels.
9	nQB3	Output	
10	V <sub>DDOB</sub>	Power	Power supply voltage for output Bank B (3.3V).
11	ND[0]	Input (PU/PD)	Control input for output Bank D. 3-level signals (see <a href="#">Table 10</a> ).

**Table 1. Pin Descriptions<sup>[a]</sup> (Cont.)**

Number	Name	Type	Description
12	ND[1]	Input (PU/PD)	Control input for output Bank D. 3-level signals (see Table 10).
13	V <sub>DDOD</sub>	Power	Power supply voltage for output Bank D (3.3V).
14	QD1	Output	Single-ended output clock. LVCMOS output levels.
15	QD0	Output	Differential clock output pair. HCSL interface levels.
16	nQD0	Output	
17	NB[0]	Input (PU/PD)	Control input for output Bank B. 3-level signals (see Table 8).
18	NB[1]	Input (PU/PD)	Control input for output Bank B. 3-level signals (see Table 8).
19	NC[0]	Input (PU/PD)	Control input for output Bank C. 3-level signals (see Table 9).
20	NC[1]	Input (PU/PD)	Control input for output Bank C. 3-level signals (see Table 9).
21	V <sub>D<sub>DA</sub>_IN1</sub>	Power	Analog power supply voltage for PLL (3.3V).
22	NA[1]	Input (PU/PD)	Control input for output Bank A. 3-level signals (see Table 7).
23	CAP <sub>BIAS</sub>	Analog	Internal VCO bias decoupling capacitor. Use a 4.7μF capacitor between the CAP <sub>BIAS</sub> terminal and GND.
24	V <sub>D<sub>DA</sub>_IN2</sub>	Power	Analog power supply voltage for VCO (3.3V).
25	CR	Analog	Internal VCO regulator decoupling capacitor. Use a 1μF capacitor between the CR and the V <sub>D<sub>DA</sub></sub> terminals.
26	CAP <sub>REG</sub>	Analog	Internal VCO regulator decoupling capacitor. Use a 4.7μF capacitor between the CAP <sub>REG</sub> terminal and GND.
27	LFFR	Analog	Ground return path pin for the PLL loop filter.
28	LFF	Output	Loop filter/charge pump output for the FemtoClock NG PLL. Connect to the external loop filter.
29	V <sub>D<sub>DA</sub></sub>	Power	Analog power supply voltage for VCO (3.3V).
30	nc	-	No connect. Do not use.
31	V <sub>DD_CP</sub>	Power	Power supply voltage for PLL charge pump (3.3V).
32	ICP	Analog	Charge pump current input for PLL. Connect to LFF pin (28).
33	V <sub>DDOC</sub>	Power	Power supply voltage for output Bank C (3.3V).
34	nQC1	Output	Differential clock output pair. HCSL interface levels.
35	QC1	Output	
36	nQC0	Output	Differential clock output pair. HCSL interface levels.
37	QC0	Output	
38	V <sub>DDOC</sub>	Power	Power supply voltage for output Bank C (3.3V).
39	V <sub>DDOA</sub>	Power	Power supply voltage for output Bank A (3.3V).

**Table 1. Pin Descriptions<sup>[a]</sup> (Cont.)**

Number	Name	Type	Description
40	nQA3	Output	Differential clock output pair. HCSL interface levels.
41	QA3	Output	
42	nQA2	Output	Differential clock output pair. HCSL interface levels.
43	QA2	Output	
44	nQA1	Output	Differential clock output pair. HCSL interface levels.
45	QA1	Output	
46	nQA0	Output	Differential clock output pair. HCSL interface levels.
47	QA0	Output	
48	V <sub>DDOA</sub>	Power	Power supply voltage for output Bank A (3.3V).
49	REF_SEL	Input (PD)	Selects input reference source. LVCMOS interface levels. 0 = Crystal input on pins OSCI, OSCO (default) 1 = Reference clock input on pins CLK, nCLK
50	V <sub>DD_CK</sub>	Power	Power supply voltage for input CLK, nCLK (3.3V).
51	nCLK	Input (PU/PD)	Inverting differential clock input. Internal resistor bias to V <sub>DD_CK</sub> /2.
52	CLK	Input (PD)	Non-inverting differential clock input.
53	FIN[1]	Input (PU/PD)	Control input for input reference frequencies. 3-level signals (see Table 3).
54	FIN[0]	Input (PU/PD)	Control input for input reference frequencies. 3-level signals (see Table 3).
55	CAP <sub>XTAL</sub>	Analog	Crystal oscillator circuit decoupling capacitor. Use a 4.7μF capacitor between the CAP <sub>XTAL</sub> and GND terminals.
56	OSCO	Output	Crystal oscillator interface.
57	OSCI	Input	Crystal oscillator interface.
58	V <sub>DDA_XT</sub>	Power	Analog power supply voltage for the crystal oscillator (3.3V).
59	NA[0]	Input (PU/PD)	Control input for output Bank A. 3-level signals (see Table 7).
60	RES	Analog	Connect a 2.8kΩ (±2%) resistor to GND for output current calibration.
61	SDATA	I/O (PU)	I <sup>2</sup> C data input/output. LVCMOS interface levels. Open-drain pin.
62	SCLK	Input (PU)	I <sup>2</sup> C clock input. LVCMOS interface levels.
63	V <sub>DD_SP</sub>	Power	Power supply voltage for the I <sup>2</sup> C port (3.3V).
64	LOCK	Output	Lock status output. LVCMOS interface levels. Logic low = PLL not locked Logic high = PLL locked
ePad	GND	Power	Power supply ground. Exposed pad must be connected to ground.

[a] Internal pull-up (PU) and pull-down (PD) resistors are indicated in parentheses. For typical values, see Table 19.

## Principles of Operation

The 8V41NS0412 can be locked to either an input reference clock or a 10MHz to 50MHz fundamental-mode crystal and generate a wide range of synchronized output clocks. Lock status can be monitored via the LOCK pin. For example, it could be used in either the transmit or receive path of Synchronous Ethernet or SONET/SDH equipment.

The 8V41NS0412 accepts a differential or single-ended input clock ranging from 5MHz up to 1GHz. It generates up to twelve output clocks with up to four different output frequencies, ranging from 10.91MHz up to 1.25GHz.

The device outputs are divided into four output banks. Each bank supports conversion of the input frequency to a different output frequency: one independent or integer related output frequency on Bank D (QD[0:1]). Three additional integer related frequencies are on Bank A (QA[0:3]), Bank B (QB[0:3]) and Bank C (QC[0:1]). All outputs within a bank will have the same frequency.

The device is programmable through an I<sup>2</sup>C serial interface by an external processor or via control input pins.

## Pin versus Register Control

The 8V41NS0412 can be configured by the use of input control pins and/or over an I<sup>2</sup>C serial port. The pins / registers used to control each function are shown in Table 2. At power-up, control of each function is via the control input pins. Access over the serial port can change each function individually to be controlled by registers. This allows for any mixture of register or pin control. However any of the indicated functions can only be controlled by register or by pin at any given time, not by both. Use of register control will allow access to a wider range of configuration options but values are lost on power-down. If the output bank or PLL is controlled by control input pins (at power-up or through the Control Select bit), corresponding register values remain unchanged and have no impact on device functions.

**Table 2. Control of Specific Functions**

Function	Control Select Bit	Control Input Pins	Register Fields Affected
Prescaler and PLL Feedback divider	FIN_CTL	FIN[1:0]	PS[5:0], FDP, M[8:0]
Bank A Divider and output type	NA_CTL	NA[1:0]	NA[5:0], PD_A, PD_QAx
Bank B Divider and output type	NB_CTL	NB[1:0]	NB[5:0], PD_B, PD_QBx
Bank C Divider and output type	NC_CTL	NC[1:0]	NC[5:0], PD_C, PD_QCx
Bank D Divider and output type	ND_CTL	ND[1:0]	ND[5:0], ND_FINT[3:0], ND_FRAC[23:0], ND_DIVF[1:0], ND_DIV, ND_SRC, PD_D, PD_QDx

Changes to the control pins while the part is active are allowed, but limited and cannot be guaranteed a glitch-free output transition. During the state transition of the control pins, the output phase alignment (synchronization) may be lost and Bank D outputs in Fractional Mode (FOD) may not be available. If the I<sup>2</sup>C registers are accessible, then assertion of the INIT\_CLK bit or powering down and then powering up the device will restore phase alignment and activate the Fractional output frequency.

Glitch-free operation can be performed by disabling the outputs using the I<sup>2</sup>C-accessible registers, then re-enabling once changes are completed.

Any change to the output dividers performed over the I<sup>2</sup>C interface must be followed by an assertion of the INIT\_CLK register bit to force the loading of the new divider values, as well as to synchronize the output dividers.

## Input Clock Selection (REF\_SEL)

The 8V41NS0412 needs to be provided with an input reference frequency either from its crystal input pins (OSCI, OSCO) or its reference clock input pins (CLK, nCLK). The REF\_SEL input pin controls which source is used.

The crystal input on the 8V41NS0412 is capable of being driven by a parallel-resonant, fundamental mode crystal with a frequency of 10MHz to 50MHz.

The crystal input also supports being driven by a single-ended crystal oscillator or reference clock, but only a frequency from 10MHz to 50MHz can be used on these pins.

The reference clock input accepts clocks with frequencies ranging from 5MHz up to 1GHz. The input can accept LVPECL, LVDS, LVHSTL, HCSL, or LVCMOS inputs using 2.5V or 3.3V logic levels as shown in [Applications Information](#).

## Prescaler and PLL Configuration

When the input frequency ( $f_{IN}$ ), whether generated by a crystal or clock input is known, and the desired PLL operating frequency has been determined, several constraints need to be met:

- The Phase/ Frequency Detector operating frequency ( $f_{PFD}$ ) must be within the specified limits shown in [Table 27](#). This is controlled by selecting a doubler (FDP) or an appropriate prescaler (PS) value. If multiple values are possible, a higher  $f_{PFD}$  will provide better phase noise performance.
- The VCO operating frequency ( $f_{VCO}$ ) must be within the specified limits shown in [Table 27](#). This is controlled by selecting an appropriate PLL feedback divider (M) value. Note that it may be necessary to choose a different prescaler value if the limits cannot be met by the available values of M. It may also be necessary to select an appropriate input frequency value.

Several preset configurations can be selected directly from the FIN[1:0] control input pins. These configurations are based on a particular input frequency  $f_{IN}$  and a particular  $f_{VCO}$  (see [Table 3](#)). These selections apply whether the input frequency is provided from the crystal or reference clock inputs

**Table 3. Input Selection Control**

FIN[1]	FIN[0]	$f_{IN}$ (MHz)	$f_{VCO}$ (MHz)
High	High	38.88	2488.32
High	Middle <sup>[a]</sup>	38.4	2457.6
High	Low	31.25	2500
Middle	High	312.5	2500
Middle	Middle	125	2500
Middle	Low	156.25	2500
Low	High	100	2500
Low	Middle	25	2500
Low	Low	50	2500

[a] A “middle” voltage level is defined in [Table 22](#). Leaving the input pin open will also generate this level via a weak internal resistor network.

Alternatively, the user can directly access the registers for M, FDP, and PS over the serial interface for a wider range of options (see [Table 4](#) for some examples).

Inputs do not support transmission of spread-spectrum clocking sources. Since this family is intended for high-performance applications, it will assume input reference sources to have stabilities of  $\pm 100$ ppm or better.

**Table 4. PLL Frequency Control Examples**

$f_{IN}$ (MHz)	PS	FDP	$f_{PFD}$ (MHz)	M	PLL Operating Frequency (MHz)
25	1	2	50	50	2500
39.0625	1	2	78.125	32	2500
50	1	2	100	25	2500
100	1	1	100	25	2500
125	1	1	125	20	2500
156.25	1	1	156.25	16	2500
200	2	1	100	25	2500
250	2	1	125	20	2500
312.5	2	1	156.25	16	2500
400	4	1	100	25	2500
500	4	1	125	20	2500
625	4	1	156.25	16	2500
19.44	1	2	38.88	64	2488.32
38.88	1	2	77.76	32	2488.32
38.4	1	2	76.8	32	2457.6

### PLL Loop Bandwidth

The 8V41NS0412 PLL requires external loop components (resistor and capacitors) connecting in between ICP and LFF pins. The PLL loop bandwidth generally depends on the loop components, charge pump current, PFD frequency, and VCO gain.

### Output Divider Frequency Sources

Output dividers associated with banks A, B and C take their input frequency directly from the PLL. Bank D also has the option to bypass the input frequency (after mux) directly to the output.

## Integer Output Dividers (Banks A, B, C, and D)

The 8V41NS0412 supports four integer output dividers: one per output bank. Each integer output divider block independently supports one of several divide ratios as shown in their respective register descriptions (Table 13, Table 14, Table 15, or Table 16). Selected divide ratios can be chosen directly from the control input pins for that particular output bank. The remaining ratios can only be selected via the serial interface. Bank D may choose whether to use the integer divider or a separate fractional divider to generate the output frequency.

Some example output frequencies are shown in Table 5 for the minimum  $f_{VCO}$  (2400MHz), the maximum  $f_{VCO}$  (2500MHz) and two other common VCO frequencies. With appropriate input frequencies and configuration selections, any  $f_{VCO}$  and  $f_{OUT}$  between the minimum and maximum can be generated.

**Table 5. Integer Output Divider Control Examples**

Divide Ratio	$f_{OUT}$ (MHz)			
	$f_{VCO} = 2400\text{MHz}$	$f_{VCO} = 2457.6\text{MHz}$	$f_{VCO} = 2488.32\text{MHz}$	$f_{VCO} = 2500\text{MHz}$
2	1200	1228.8	1244.16	1250
4	600	614.4	622.08	625
5	480	491.52	497.664	500
6	400	409.6	414.72	416.667
8	300	307.2	311.04	312.5
9	266.667	273.07	276.48	277.78
10	240	245.76	248.832	250
12	200	204.8	207.36	208.333
16	150	153.6	155.52	156.25
18	133.333	136.533	138.24	138.889
20	120	122.88	124.416	125
25	96	98.3	99.53	100
32	75	76.8	77.76	78.125
36	66.667	68.267	69.12	69.444
40	60	61.44	62.208	62.5
50	48	49.152	49.766	50
64	37.5	38.4	38.88	39.063
72	33.333	34.133	34.56	34.722
80	30	30.72	31.104	31.25
100	24	24.576	24.883	25
128	18.75	19.2	19.44	19.531
160	15	15.36	15.552	15.625
200	12	12.29	12.44	12.5
220	10.91	11.17	11.31	11.36

## Fractional Output Divider (Bank D)

For the fractional output divider in Bank D, the output divide ratio is given by:

$$f_{OUT} = \frac{f_{VCO}}{2 \times \left( FINT + \frac{FRAC}{2^{24}} \right) \times (FDIV)}$$

Where,

- FINT = Integer part: 5, 6, ... $(2^4-1)$  – given by ND\_FINT[3:0]
- FRAC = Fractional part: 0, 1, 2, ... $(2^{24}-1)$  – given by ND\_FRAC[23:0]
- FDIV = post-divider: 1, 2 or 4 – given by ND\_DIVF[1:0]

This provides a frequency range of 20 to 250MHz.

## Output Drivers

Each of the four output banks are provided with pin or register-controlled output drivers. Differential outputs can be individually selected as HCSL or POWER-DOWN. When powered-down, both outputs of the differential output pair and the single-ended QD1 output will be in High-Impedance state.

Note that under pin-control, all differential outputs within an output bank will assume the same configuration. Pin-control does not allow configuration of individual outputs within a bank.

### Pin Control of the Output Frequencies and Protocols

For pin-control settings, see [Table 6](#) to [Table 10](#). All of the output frequencies assume  $f_{VCO} = 2500\text{MHz}$ . With different  $f_{VCO}$  configurations, the pins may still be used to select the indicated divide ratios for each bank, but the  $f_{OUT}$  will be different.

The control pins do not affect the internal register values but act directly on the output structures. As a result, register values will not change to match the control input pin selections.

Each output bank can be powered up/down and enabled/ disabled by register bits. In the disabled state, an output will drive a logic low level. The default state is all outputs enabled. Pin-control does not require register access to enable the outputs. Additionally, individual outputs within a bank can be powered up/down by register bits only.

**Table 6. Definition of Output Disabled / Power-down<sup>[a]</sup>**

Output Condition	$Q_{MN}^{[b]}$	$nQ_{MN}^{[c]}$	QD1
DISABLED (register-control only)	LOW	HIGH	LOW
Buffer POWER-DOWN (pin-control or register-control)	High-Impedance	High-Impedance	High-Impedance

[a] Do not terminate the differential outputs when DISABLED or POWER-DOWN.

[b]  $Q_{MN}$  refers to output pins QA[0:3], QB[0:3], QC[0:1], and QD0.

[c]  $nQ_{MN}$  refers to output pins nQA[0:3], nQB[0:3], nQC[0:1], and nQD0.

**Table 7. Bank A Divider / Driver Pin-Control**

(3-level control signals)

NA[1]	NA[0]	Output Type	Divide Ratio	f <sub>OUT</sub> (MHz)
Low	Low	HCSL	16	156.25
Low	Middle	HCSL	10	250
Low	High	HCSL	8	312.5
Middle	Low	HCSL	5	500
Middle	Middle	PD <sup>[a]</sup>	–	–
Middle	High	HCSL	20	125
High	Low	HCSL	25	100
High	Middle	HCSL	50	50
High	High	Reserved <sup>[b]</sup>		

[a] PD denotes Power-down.

[b] It is imperative not to connect or switch NA[1] and NA[0] pins to HIGH/Power Supply (V<sub>DD</sub>) at any time

**Table 9. Bank C Divider / Driver Pin-Control**

(3-level control signals)

NC[1]	NC[0]	Output Type	Divide Ratio	f <sub>OUT</sub> (MHz)
Low	Low	HCSL	16	156.25
Low	Middle	HCSL	10	250
Low	High	HCSL	8	312.5
Middle	Low	HCSL	5	500
Middle	Middle	PD <sup>[a]</sup>	–	–
Middle	High	HCSL	20	125
High	Low	HCSL	25	100
High	Middle	HCSL	50	50
High	High	HCSL	100	25

[a] PD denotes Power-down.

**Table 8. Bank B Divider / Driver Pin-Control**

(3-level control signals)

NB[1]	NB[0]	Output Type	Divide Ratio	f <sub>OUT</sub> (MHz)
Low	Low	HCSL	16	156.25
Low	Middle	HCSL	10	250
Low	High	HCSL	8	312.5
Middle	Low	HCSL	5	500
Middle	Middle	PD <sup>[a]</sup>	–	–
Middle	High	HCSL	20	125
High	Low	HCSL	25	100
High	Middle	HCSL	50	50
High	High	HCSL	100	25

[a] PD denotes Power-down.

**Table 10. Bank D Divider / Driver Pin-Control**

(3-level control signals)

ND[1]	ND[0]	QD0	QD1	Divide Ratio	f <sub>OUT</sub> (MHz)
		Output Type			
Low	Low	HCSL	Hi-Imp <sup>[a]</sup>	16	156.25
Low	Middle	HCSL	Hi-Imp	20	125
Low	High	HCSL	Hi-Imp	25	100
Middle	Low	PD	LVC MOS	75	33.333
Middle	Middle	PD <sup>[b]</sup>	Hi-Imp	–	–
Middle	High	–	–	–	–
High	Low	HCSL	Hi-Imp	18.75	133.33
High	Middle	HCSL	Hi-Imp	37.5	66.66
High	High	HCSL	LVC MOS	N/A	f <sub>IN</sub>

[a] Hi-Imp denotes High-Impedance.

[b] PD denotes Power-down.

## Device Start-up and Reset Behavior

The 8V41NS0412 has an internal power-on reset (POR) circuit. The POR circuit will remain active for a maximum of 175msec after device power-up when recommended CR (pin 25) value is used, 1.0uF. For faster power-up to Lock Time, a minimum CR value of 0.1uF can be used.

While in the reset state (POR active), the device will operate as follows:

1. All registers will return to and be held in their default states as indicated in the applicable register description.
2. All internal state machines will be in their reset conditions.
3. The serial interface will not respond to read or write cycles.
4. Lock status will be cleared.

Upon the internal POR circuit expiring, the device will exit reset and begin self-configuration. Self-configuration initiates the loading of appropriate values indicated by the control input pins and the default values into the registers indicated in the register descriptions.

Once the full configuration has been loaded, the device will respond to accesses on the serial port and will attempt to lock the PLL to the input frequency, if available. Once the PLL is locked, all the outputs will be synchronized.

## Serial Control Port Description

### Serial Control Port Configuration Description

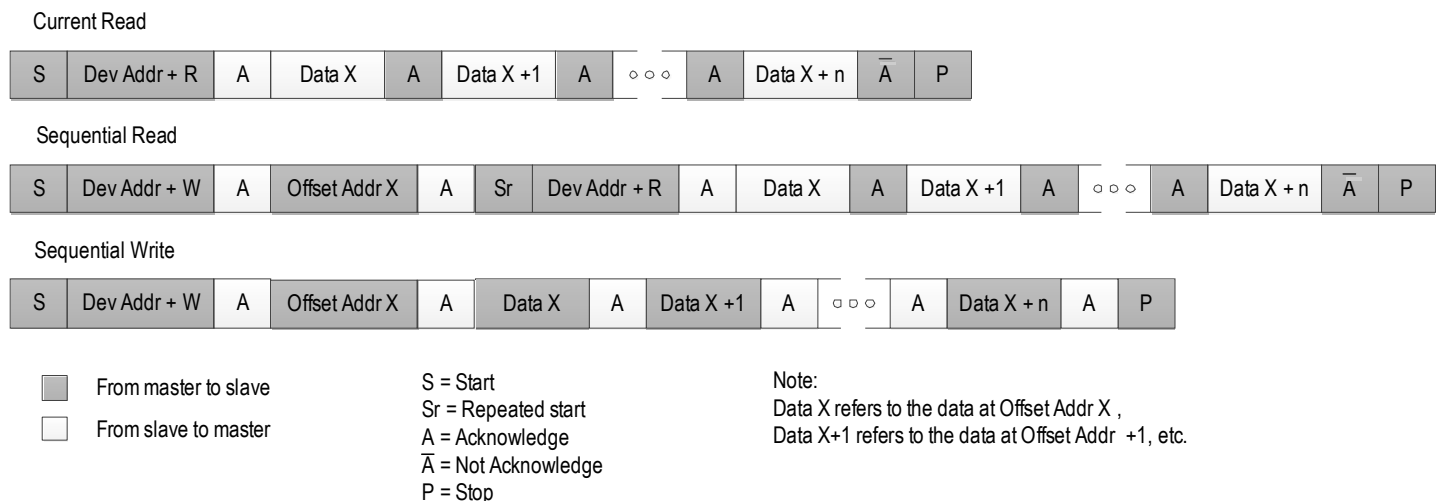
The 8V41NS0412 has a serial control port that can respond as a slave in an I<sup>2</sup>C compatible configuration at a base address of 1101100b, to allow access to any of the internal registers for device programming or examination of internal status.

### I<sup>2</sup>C Mode Operation

The I<sup>2</sup>C interface is designed to fully support v1.2 of the I<sup>2</sup>C Specification for Fast mode operation. The 8V41NS0412 acts as a slave device on the I<sup>2</sup>C bus at 400kHz using a fixed base address of 1101100b. The interface accepts byte-oriented block write and block read operations. One address byte specifies the register address of the byte position of the first register to write or read. Data bytes (registers) are accessed in sequential order from the lowest to the highest byte (most significant bit first). Read and write block transfers can be stopped after any complete byte transfer.

For full electrical I<sup>2</sup>C compliance, it is recommended to use external pull-up resistors for SDATA and SCLK. The internal pull-up resistors have a size of 51kΩ typical.

**Figure 3. I<sup>2</sup>C Slave Read and Write Cycle Sequencing**



## Register Description

**Table 11. Register Blocks**

Register Ranges Offset (Hex)	Register Block Description
00–08	Prescaler and PLL Control Registers
09–0F	Reserved <sup>[a]</sup>
10–17	Bank A Control Registers
18–1F	Bank B Control Registers
20–27	Bank C Control Registers
28–31	Bank D Control Registers
32–3C	Reserved
3D–40	Device Control Registers
41–FF	Reserved

[a] Reserved registers should not be written to and have indeterminate read values.

**Table 12. Prescaler and PLL Control Register Bit Field Locations and Descriptions**

Prescaler and PLL Control Register Block Field Locations									
Address (Hex)	D7	D6	D5	D4	D3	D2	D1	D0	
00	Rsvd	Rsvd	PS[5:0]						
01	Rsvd							FDP	
02	Rsvd					FIN_CTL	OSC_LOW		
03	Rsvd								
04	Rsvd							M[8]	
05	M[7:0]								
06	Rsvd								
07	Rsvd								
08	Rsvd			CP[4:0]					

Prescaler and PLL Control Register Block Field Descriptions			
Bit Field Name	Field Type	Default Value	Description
PS[5:0]	R/W	000000b	Prescaler – scales input frequency by the value: 00h = Reserved 01h – 3Fh = divide by the value used (e.g. 04 = divide-by-4) Note: When FDP = 1, prescaler values are ignored and have no impact on device functions.
FDP	R/W	1b	Input Frequency Doubler: 0 = Disabled 1 = Enabled
FIN_CTL	R/W	0b	Prescaler and PLL Configuration Control: 0 = PS, FDP, and M settings determined by FIN[1:0] control pins 1 = PS, FDP, and M settings determined by register settings over I <sup>2</sup> C
OSC_LOW	R/W	0b	Crystal Oscillator Gain Control Selection: 0 = Normal gain for crystal frequencies of 25MHz and up 1 = Low gain for crystal frequencies less than 25MHz
M[8:0]	R/W	019h	PLL Feedback Divider Ratio: 000h–003h = Reserved (do not use) 004h–1FFh = Divide f <sub>VCO</sub> by the value (e.g. 04 = divide by -4)
CP[4:0]	R/W	11001b	PLL Charge Pump Current Control: I <sub>CP</sub> = 200µA × (CP[4:0] + 1) Maximum charge pump current is 6.4mA. Default setting is 5.2mA: ((25 + 1) × 200µA).
Rsvd	R/W	-	Reserved. Always write 0 to this bit location. Read values are not defined.

**Table 13. Bank A Control Register Bit Field Locations and Descriptions**

Bank A Control Register Block Field Locations								
Address (Hex)	D7	D6	D5	D4	D3	D2	D1	D0
10	Rsvd		NA[5:0]					
11	Rsvd							
12	PD_A	Rsvd					NA_CTL	
13	Rsvd							
14	PD_QA0	Rsvd						
15	PD_QA1	Rsvd						
16	PD_QA2	Rsvd						
17	PD_QA3	Rsvd						

Bank A Control Register Block Field Descriptions																																																																		
Bit Field Name <sup>[a]</sup>	Field Type	Default Value	Description																																																															
NA[5:0]	R/W	0Dh	Divider Ratio for Bank A: Any changes made to this register will not take effect until the INIT_CLK register bit is toggled.																																																															
			<table border="0"> <tr> <td>00 0000b = Reserved</td> <td>01 0110b = +30</td> <td>10 1011b = +88</td> </tr> <tr> <td>00 0001b = Reserved</td> <td>01 0111b = +32</td> <td>10 1100b = +90</td> </tr> <tr> <td>00 0010b = +2</td> <td>01 1000b = +33</td> <td>10 1101b = +96</td> </tr> <tr> <td>00 0011b = +3</td> <td>01 1001b = +35</td> <td>10 1110b = +100</td> </tr> <tr> <td>00 0100b = +4</td> <td>01 1010b = +36</td> <td>10 1111b = +108</td> </tr> <tr> <td>00 0101b = +5</td> <td>01 1011b = +40</td> <td>11 0000b = +110</td> </tr> <tr> <td>00 0110b = +6</td> <td>01 1100b = +42</td> <td>11 0001b = +112</td> </tr> <tr> <td>00 0111b = +8</td> <td>01 1101b = +44</td> <td>11 0010b = +120</td> </tr> <tr> <td>00 1000b = +9</td> <td>01 1110b = +45</td> <td>11 0011b = +128</td> </tr> <tr> <td>00 1001b = +10</td> <td>01 1111b = +48</td> <td>11 0100b = +132</td> </tr> <tr> <td>00 1010b = +12</td> <td>10 0000b = +50</td> <td>11 0101b = +140</td> </tr> <tr> <td>00 1011b = +14</td> <td>10 0001b = +54</td> <td>11 0110b = +144</td> </tr> <tr> <td>00 1100b = +15</td> <td>10 0010b = +55</td> <td>11 0111b = +160</td> </tr> <tr> <td>00 1101b = +16</td> <td>10 0011b = +56</td> <td>11 1000b = +176</td> </tr> <tr> <td>00 1110b = +18</td> <td>10 0100b = +60</td> <td>11 1001b = +180</td> </tr> <tr> <td>00 1111b = +20</td> <td>10 0101b = +64</td> <td>11 1010b = +200</td> </tr> <tr> <td>01 0000b = +21</td> <td>10 0110b = +66</td> <td>11 1011b = +220</td> </tr> <tr> <td>01 0001b = +22</td> <td>10 0111b = +70</td> <td>11 1100b = Reserved</td> </tr> <tr> <td>01 0010b = +24</td> <td>10 1000b = +72</td> <td>11 1101b = Reserved</td> </tr> <tr> <td>01 0011b = +25</td> <td>10 1001b = +80</td> <td>11 1110b = Reserved</td> </tr> <tr> <td>01 0100b = +27</td> <td>10 1010b = +84</td> <td>11 1111b = Reserved</td> </tr> <tr> <td>01 0101b = +28</td> <td></td> <td></td> </tr> </table>	00 0000b = Reserved	01 0110b = +30	10 1011b = +88	00 0001b = Reserved	01 0111b = +32	10 1100b = +90	00 0010b = +2	01 1000b = +33	10 1101b = +96	00 0011b = +3	01 1001b = +35	10 1110b = +100	00 0100b = +4	01 1010b = +36	10 1111b = +108	00 0101b = +5	01 1011b = +40	11 0000b = +110	00 0110b = +6	01 1100b = +42	11 0001b = +112	00 0111b = +8	01 1101b = +44	11 0010b = +120	00 1000b = +9	01 1110b = +45	11 0011b = +128	00 1001b = +10	01 1111b = +48	11 0100b = +132	00 1010b = +12	10 0000b = +50	11 0101b = +140	00 1011b = +14	10 0001b = +54	11 0110b = +144	00 1100b = +15	10 0010b = +55	11 0111b = +160	00 1101b = +16	10 0011b = +56	11 1000b = +176	00 1110b = +18	10 0100b = +60	11 1001b = +180	00 1111b = +20	10 0101b = +64	11 1010b = +200	01 0000b = +21	10 0110b = +66	11 1011b = +220	01 0001b = +22	10 0111b = +70	11 1100b = Reserved	01 0010b = +24	10 1000b = +72	11 1101b = Reserved	01 0011b = +25	10 1001b = +80	11 1110b = Reserved	01 0100b = +27	10 1010b = +84	11 1111b = Reserved
00 0000b = Reserved	01 0110b = +30	10 1011b = +88																																																																
00 0001b = Reserved	01 0111b = +32	10 1100b = +90																																																																
00 0010b = +2	01 1000b = +33	10 1101b = +96																																																																
00 0011b = +3	01 1001b = +35	10 1110b = +100																																																																
00 0100b = +4	01 1010b = +36	10 1111b = +108																																																																
00 0101b = +5	01 1011b = +40	11 0000b = +110																																																																
00 0110b = +6	01 1100b = +42	11 0001b = +112																																																																
00 0111b = +8	01 1101b = +44	11 0010b = +120																																																																
00 1000b = +9	01 1110b = +45	11 0011b = +128																																																																
00 1001b = +10	01 1111b = +48	11 0100b = +132																																																																
00 1010b = +12	10 0000b = +50	11 0101b = +140																																																																
00 1011b = +14	10 0001b = +54	11 0110b = +144																																																																
00 1100b = +15	10 0010b = +55	11 0111b = +160																																																																
00 1101b = +16	10 0011b = +56	11 1000b = +176																																																																
00 1110b = +18	10 0100b = +60	11 1001b = +180																																																																
00 1111b = +20	10 0101b = +64	11 1010b = +200																																																																
01 0000b = +21	10 0110b = +66	11 1011b = +220																																																																
01 0001b = +22	10 0111b = +70	11 1100b = Reserved																																																																
01 0010b = +24	10 1000b = +72	11 1101b = Reserved																																																																
01 0011b = +25	10 1001b = +80	11 1110b = Reserved																																																																
01 0100b = +27	10 1010b = +84	11 1111b = Reserved																																																																
01 0101b = +28																																																																		

Bank A Control Register Block Field Descriptions			
Bit Field Name <sup>[a]</sup>	Field Type	Default Value	Description
PD_A	R/W	0b	Power-down Bank A: 0 = Bank A and all QA outputs powered and operate normally. 1 = Bank A and all QA outputs powered-down. When powering-down the output bank, it is recommended to also write a 1 to the PD_QAx registers.
NA_CTL	R/W	0b	Bank A Configuration Control: 0 = NA[5:0] and PD_A settings are determined by NA[1:0] control pins 1 = NA[5:0] and PD_A settings are determined by register settings over I <sup>2</sup> C
PD_QAx	R/W	0b	Power-down Output QAx: 0 = QAx output powered and operates normally 1 = QAx output powered-down
Rsvd	R/W	-	Reserved. Always write 0 to this bit location. Read values are not defined.

[a] Where x = 0, 1, 2, or 3.

**Table 14. Bank B Control Register Bit Field Locations and Descriptions**

Bank B Control Register Block Field Locations								
Address (Hex)	D7	D6	D5	D4	D3	D2	D1	D0
18	Rsvd		NB[5:0]					
19	Rsvd							
1A	PD_B	Rsvd					NB_CTL	
1B	Rsvd							
1C	PD_QB0	Rsvd						
1D	PD_QB1	Rsvd						
1E	PD_QB2	Rsvd						
1F	PD_QB3	Rsvd						

Bank B Control Register Block Field Descriptions																																																																		
Bit Field Name <sup>[a]</sup>	Field Type	Default Value	Description																																																															
NB[5:0]	R/W	0Dh	Divider Ratio for Bank B: Any changes made to this register will not take effect until the INIT_CLK register bit is toggled.																																																															
			<table border="0"> <tr> <td>00 0000b = Reserved</td> <td>01 0110b = ÷30</td> <td>10 1011b = ÷88</td> </tr> <tr> <td>00 0001b = Reserved</td> <td>01 0111b = ÷32</td> <td>10 1100b = ÷90</td> </tr> <tr> <td>00 0010b = ÷2</td> <td>01 1000b = ÷33</td> <td>10 1101b = ÷96</td> </tr> <tr> <td>00 0011b = ÷3</td> <td>01 1001b = ÷35</td> <td>10 1110b = ÷100</td> </tr> <tr> <td>00 0100b = ÷4</td> <td>01 1010b = ÷36</td> <td>10 1111b = ÷108</td> </tr> <tr> <td>00 0101b = ÷5</td> <td>01 1011b = ÷40</td> <td>11 0000b = ÷110</td> </tr> <tr> <td>00 0110b = ÷6</td> <td>01 1100b = ÷42</td> <td>11 0001b = ÷112</td> </tr> <tr> <td>00 0111b = ÷8</td> <td>01 1101b = ÷44</td> <td>11 0010b = ÷120</td> </tr> <tr> <td>00 1000b = ÷9</td> <td>01 1110b = ÷45</td> <td>11 0011b = ÷128</td> </tr> <tr> <td>00 1001b = ÷10</td> <td>01 1111b = ÷48</td> <td>11 0100b = ÷132</td> </tr> <tr> <td>00 1010b = ÷12</td> <td>10 0000b = ÷50</td> <td>11 0101b = ÷140</td> </tr> <tr> <td>00 1011b = ÷14</td> <td>10 0001b = ÷54</td> <td>11 0110b = ÷144</td> </tr> <tr> <td>00 1100b = ÷15</td> <td>10 0010b = ÷55</td> <td>11 0111b = ÷160</td> </tr> <tr> <td>00 1101b = ÷16</td> <td>10 0011b = ÷56</td> <td>11 1000b = ÷176</td> </tr> <tr> <td>00 1110b = ÷18</td> <td>10 0100b = ÷60</td> <td>11 1001b = ÷180</td> </tr> <tr> <td>00 1111b = ÷20</td> <td>10 0101b = ÷64</td> <td>11 1010b = ÷200</td> </tr> <tr> <td>01 0000b = ÷21</td> <td>10 0110b = ÷66</td> <td>11 1011b = ÷220</td> </tr> <tr> <td>01 0001b = ÷22</td> <td>10 0111b = ÷70</td> <td>11 1100b = Reserved</td> </tr> <tr> <td>01 0010b = ÷24</td> <td>10 1000b = ÷72</td> <td>11 1101b = Reserved</td> </tr> <tr> <td>01 0011b = ÷25</td> <td>10 1001b = ÷80</td> <td>11 1110b = Reserved</td> </tr> <tr> <td>01 0100b = ÷27</td> <td>10 1010b = ÷84</td> <td>11 1111b = Reserved</td> </tr> <tr> <td>01 0101b = ÷28</td> <td></td> <td></td> </tr> </table>	00 0000b = Reserved	01 0110b = ÷30	10 1011b = ÷88	00 0001b = Reserved	01 0111b = ÷32	10 1100b = ÷90	00 0010b = ÷2	01 1000b = ÷33	10 1101b = ÷96	00 0011b = ÷3	01 1001b = ÷35	10 1110b = ÷100	00 0100b = ÷4	01 1010b = ÷36	10 1111b = ÷108	00 0101b = ÷5	01 1011b = ÷40	11 0000b = ÷110	00 0110b = ÷6	01 1100b = ÷42	11 0001b = ÷112	00 0111b = ÷8	01 1101b = ÷44	11 0010b = ÷120	00 1000b = ÷9	01 1110b = ÷45	11 0011b = ÷128	00 1001b = ÷10	01 1111b = ÷48	11 0100b = ÷132	00 1010b = ÷12	10 0000b = ÷50	11 0101b = ÷140	00 1011b = ÷14	10 0001b = ÷54	11 0110b = ÷144	00 1100b = ÷15	10 0010b = ÷55	11 0111b = ÷160	00 1101b = ÷16	10 0011b = ÷56	11 1000b = ÷176	00 1110b = ÷18	10 0100b = ÷60	11 1001b = ÷180	00 1111b = ÷20	10 0101b = ÷64	11 1010b = ÷200	01 0000b = ÷21	10 0110b = ÷66	11 1011b = ÷220	01 0001b = ÷22	10 0111b = ÷70	11 1100b = Reserved	01 0010b = ÷24	10 1000b = ÷72	11 1101b = Reserved	01 0011b = ÷25	10 1001b = ÷80	11 1110b = Reserved	01 0100b = ÷27	10 1010b = ÷84	11 1111b = Reserved
00 0000b = Reserved	01 0110b = ÷30	10 1011b = ÷88																																																																
00 0001b = Reserved	01 0111b = ÷32	10 1100b = ÷90																																																																
00 0010b = ÷2	01 1000b = ÷33	10 1101b = ÷96																																																																
00 0011b = ÷3	01 1001b = ÷35	10 1110b = ÷100																																																																
00 0100b = ÷4	01 1010b = ÷36	10 1111b = ÷108																																																																
00 0101b = ÷5	01 1011b = ÷40	11 0000b = ÷110																																																																
00 0110b = ÷6	01 1100b = ÷42	11 0001b = ÷112																																																																
00 0111b = ÷8	01 1101b = ÷44	11 0010b = ÷120																																																																
00 1000b = ÷9	01 1110b = ÷45	11 0011b = ÷128																																																																
00 1001b = ÷10	01 1111b = ÷48	11 0100b = ÷132																																																																
00 1010b = ÷12	10 0000b = ÷50	11 0101b = ÷140																																																																
00 1011b = ÷14	10 0001b = ÷54	11 0110b = ÷144																																																																
00 1100b = ÷15	10 0010b = ÷55	11 0111b = ÷160																																																																
00 1101b = ÷16	10 0011b = ÷56	11 1000b = ÷176																																																																
00 1110b = ÷18	10 0100b = ÷60	11 1001b = ÷180																																																																
00 1111b = ÷20	10 0101b = ÷64	11 1010b = ÷200																																																																
01 0000b = ÷21	10 0110b = ÷66	11 1011b = ÷220																																																																
01 0001b = ÷22	10 0111b = ÷70	11 1100b = Reserved																																																																
01 0010b = ÷24	10 1000b = ÷72	11 1101b = Reserved																																																																
01 0011b = ÷25	10 1001b = ÷80	11 1110b = Reserved																																																																
01 0100b = ÷27	10 1010b = ÷84	11 1111b = Reserved																																																																
01 0101b = ÷28																																																																		

Bank B Control Register Block Field Descriptions			
Bit Field Name <sup>[a]</sup>	Field Type	Default Value	Description
PD_B	R/W	0b	Power-down Bank B: 0 = Bank B and all QB outputs powered and operate normally 1 = Bank B and all QB outputs powered-down. When powering-down the output bank, it is recommended to also write a 1 to the PD_QBx registers.
NB_CTL	R/W	0b	Bank B Configuration Control: 0 = NB[5:0] and PD_B settings are determined by NB[1:0] control pins 1 = NB[5:0] and PD_B settings are determined by register settings over I <sup>2</sup> C
PD_QBx	R/W	0b	Power-down Output QBx: 0 = QBx output powered and operates normally. 1 = QBx output powered-down
Rsvd	R/W	-	Reserved. Always write 0 to this bit location. Read values are not defined.

[a] Where x = 0, 1, 2, or 3.

**Table 15. Bank C Control Register Bit Field Locations and Descriptions**

Bank C Control Register Block Field Locations								
Address (Hex)	D7	D6	D5	D4	D3	D2	D1	D0
20	Rsvd		NC[5:0]					
21	Rsvd							
22	PD_C	Rsvd					NC_CTL	
23	Rsvd							
24	PD_QC0	Rsvd						Rsvd
25	PD_QC1	Rsvd						Rsvd

Bank C Control Register Block Field Descriptions																																																																					
Bit Field Name <sup>[a]</sup>	Field Type	Default Value	Description																																																																		
NC[5:0]	R/W	0Dh	Divider Ratio for Bank C: Any changes made to this register will not take effect until the INIT_CLK register bit is toggled.																																																																		
			<table border="0"> <tr> <td>00 0000b = Reserved</td> <td>01 0110b = +30</td> <td>10 1011b = +88</td> </tr> <tr> <td>00 0001b = Reserved</td> <td>01 0111b = +32</td> <td>10 1100b = +90</td> </tr> <tr> <td>00 0010b = +2</td> <td>01 1000b = +33</td> <td>10 1101b = +96</td> </tr> <tr> <td>00 0011b = +3</td> <td>01 1001b = +35</td> <td>10 1110b = +100</td> </tr> <tr> <td>00 0100b = +4</td> <td>01 1010b = +36</td> <td>10 1111b = +108</td> </tr> <tr> <td>00 0101b = +5</td> <td>01 1011b = +40</td> <td>11 0000b = +110</td> </tr> <tr> <td>00 0110b = +6</td> <td>01 1100b = +42</td> <td>11 0001b = +112</td> </tr> <tr> <td>00 0111b = +8</td> <td>01 1101b = +44</td> <td>11 0010b = +120</td> </tr> <tr> <td>00 1000b = +9</td> <td>01 1110b = +45</td> <td>11 0011b = +128</td> </tr> <tr> <td>00 1001b = +10</td> <td>01 1111b = +48</td> <td>11 0100b = +132</td> </tr> <tr> <td>00 1010b = +12</td> <td>10 0000b = +50</td> <td>11 0101b = +140</td> </tr> <tr> <td>00 1011b = +14</td> <td>10 0001b = +54</td> <td>11 0110b = +144</td> </tr> <tr> <td>00 1100b = +15</td> <td>10 0010b = +55</td> <td>11 0111b = +160</td> </tr> <tr> <td>00 1101b = +16</td> <td>10 0011b = +56</td> <td>11 1000b = +176</td> </tr> <tr> <td>00 1110b = +18</td> <td>10 0100b = +60</td> <td>11 1001b = +180</td> </tr> <tr> <td>00 1111b = +20</td> <td>10 0101b = +64</td> <td>11 1010b = +200</td> </tr> <tr> <td>01 0000b = +21</td> <td>10 0110b = +66</td> <td>11 1011b = +220</td> </tr> <tr> <td>01 0001b = +22</td> <td>10 0111b = +70</td> <td>11 1100b = Reserved</td> </tr> <tr> <td>01 0010b = +24</td> <td>10 1000b = +72</td> <td>11 1101b = Reserved</td> </tr> <tr> <td>01 0011b = +25</td> <td>10 1001b = +80</td> <td>11 1110b = Reserved</td> </tr> <tr> <td>01 0100b = +27</td> <td>10 1010b = +84</td> <td>11 1111b = Reserved</td> </tr> <tr> <td>01 0101b = +28</td> <td></td> <td></td> </tr> </table>	00 0000b = Reserved	01 0110b = +30	10 1011b = +88	00 0001b = Reserved	01 0111b = +32	10 1100b = +90	00 0010b = +2	01 1000b = +33	10 1101b = +96	00 0011b = +3	01 1001b = +35	10 1110b = +100	00 0100b = +4	01 1010b = +36	10 1111b = +108	00 0101b = +5	01 1011b = +40	11 0000b = +110	00 0110b = +6	01 1100b = +42	11 0001b = +112	00 0111b = +8	01 1101b = +44	11 0010b = +120	00 1000b = +9	01 1110b = +45	11 0011b = +128	00 1001b = +10	01 1111b = +48	11 0100b = +132	00 1010b = +12	10 0000b = +50	11 0101b = +140	00 1011b = +14	10 0001b = +54	11 0110b = +144	00 1100b = +15	10 0010b = +55	11 0111b = +160	00 1101b = +16	10 0011b = +56	11 1000b = +176	00 1110b = +18	10 0100b = +60	11 1001b = +180	00 1111b = +20	10 0101b = +64	11 1010b = +200	01 0000b = +21	10 0110b = +66	11 1011b = +220	01 0001b = +22	10 0111b = +70	11 1100b = Reserved	01 0010b = +24	10 1000b = +72	11 1101b = Reserved	01 0011b = +25	10 1001b = +80	11 1110b = Reserved	01 0100b = +27	10 1010b = +84	11 1111b = Reserved	01 0101b = +28		
			00 0000b = Reserved	01 0110b = +30	10 1011b = +88																																																																
			00 0001b = Reserved	01 0111b = +32	10 1100b = +90																																																																
			00 0010b = +2	01 1000b = +33	10 1101b = +96																																																																
			00 0011b = +3	01 1001b = +35	10 1110b = +100																																																																
			00 0100b = +4	01 1010b = +36	10 1111b = +108																																																																
			00 0101b = +5	01 1011b = +40	11 0000b = +110																																																																
			00 0110b = +6	01 1100b = +42	11 0001b = +112																																																																
			00 0111b = +8	01 1101b = +44	11 0010b = +120																																																																
			00 1000b = +9	01 1110b = +45	11 0011b = +128																																																																
			00 1001b = +10	01 1111b = +48	11 0100b = +132																																																																
			00 1010b = +12	10 0000b = +50	11 0101b = +140																																																																
			00 1011b = +14	10 0001b = +54	11 0110b = +144																																																																
			00 1100b = +15	10 0010b = +55	11 0111b = +160																																																																
			00 1101b = +16	10 0011b = +56	11 1000b = +176																																																																
			00 1110b = +18	10 0100b = +60	11 1001b = +180																																																																
			00 1111b = +20	10 0101b = +64	11 1010b = +200																																																																
			01 0000b = +21	10 0110b = +66	11 1011b = +220																																																																
			01 0001b = +22	10 0111b = +70	11 1100b = Reserved																																																																
01 0010b = +24	10 1000b = +72	11 1101b = Reserved																																																																			
01 0011b = +25	10 1001b = +80	11 1110b = Reserved																																																																			
01 0100b = +27	10 1010b = +84	11 1111b = Reserved																																																																			
01 0101b = +28																																																																					
PD_C	R/W	0b	Power-down Bank C: 0 = Bank C and all QC outputs powered and operate normally 1 = Bank C and all QC outputs powered-down. When powering-down the output bank, it is recommended to also write a 1 to the PD_QCx registers.																																																																		

Bank C Control Register Block Field Descriptions			
Bit Field Name <sup>[a]</sup>	Field Type	Default Value	Description
NC_CTL	R/W	0b	Bank C Configuration Control: 0 = NC[5:0] and PD_C settings are determined by NC[1:0] control pins 1 = NC[5:0] and PD_C settings are determined by register settings over I <sup>2</sup> C
PD_QCx	R/W	0b	Power-down Output QCx: 0 = QCx output powered and operates normally. 1 = QCx output powered-down.
Rsvd	R/W	-	Reserved. Always write 0 to this bit location. Read values are not defined.

[a] Where x = 0 or 1.

**Table 16. Bank D Control Register Bit Field Locations and Descriptions**

Bank D Control Register Block Field Locations								
Address (Hex)	D7	D6	D5	D4	D3	D2	D1	D0
28	ND_FRAC[7:0]							
29	ND_FRAC[15:8]							
2A	ND_FRAC[23:16]							
2B	Rsvd				ND_FINT[3:0]			
2C	Rsvd		ND[5:0]					
2D	Rsvd				ND_DIVF[1:0]		ND_DIV	ND_SRC
2E	PD_D	Rsvd						ND_CTL
2F	Rsvd							
30	PD_QD0	Rsvd						
31	PD_QD1	Rsvd						

Bank D Control Register Block Field Descriptions			
Bit Field Name <sup>[a]</sup>	Field Type	Default Value	Description
ND_FRAC[23:0]	R/W	600000h	Fractional portion of divider ratio for fractional divider for Bank D: Fraction used in divide ratio = ND_FRAC[23:0] / 2 <sup>24</sup>
ND_FINT[3:0]	R/W	1001b	Integer portion of divider ratio for fractional divider for Bank D: 0h–4h= Reserved 5h–Fh = divide by the value used (e.g. 5 = divide-by-5)

Bank D Control Register Block Field Descriptions																																																																		
Bit Field Name <sup>[a]</sup>	Field Type	Default Value	Description																																																															
ND[5:0]	R/W	0Dh	Divider Ratio for Bank D: Any changes made to this register will not take effect until the INIT_CLK register bit is toggled.																																																															
			<table border="0"> <tr> <td>00 0000b = Reserved</td> <td>01 0110b = ÷ 30</td> <td>10 1011b = ÷ 88</td> </tr> <tr> <td>00 0001b = Reserved</td> <td>01 0111b = ÷ 32</td> <td>10 1100b = ÷ 90</td> </tr> <tr> <td>00 0010b = ÷ 2</td> <td>01 1000b = ÷ 33</td> <td>10 1101b = ÷ 96</td> </tr> <tr> <td>00 0011b = ÷ 3</td> <td>01 1001b = ÷ 35</td> <td>10 1110b = ÷ 100</td> </tr> <tr> <td>00 0100b = ÷ 4</td> <td>01 1010b = ÷ 36</td> <td>10 1111b = ÷ 108</td> </tr> <tr> <td>00 0101b = ÷ 5</td> <td>01 1011b = ÷ 40</td> <td>11 0000b = ÷ 110</td> </tr> <tr> <td>00 0110b = ÷ 6</td> <td>01 1100b = ÷ 42</td> <td>11 0001b = ÷ 112</td> </tr> <tr> <td>00 0111b = ÷ 8</td> <td>01 1101b = ÷ 44</td> <td>11 0010b = ÷ 120</td> </tr> <tr> <td>00 1000b = ÷ 9</td> <td>01 1110b = ÷ 45</td> <td>11 0011b = ÷ 128</td> </tr> <tr> <td>00 1001b = ÷ 10</td> <td>01 1111b = ÷ 48</td> <td>11 0100b = ÷ 132</td> </tr> <tr> <td>00 1010b = ÷ 12</td> <td>10 0000b = ÷ 50</td> <td>11 0101b = ÷ 140</td> </tr> <tr> <td>00 1011b = ÷ 14</td> <td>10 0001b = ÷ 54</td> <td>11 0110b = ÷ 144</td> </tr> <tr> <td>00 1100b = ÷ 15</td> <td>10 0010b = ÷ 55</td> <td>11 0111b = ÷ 160</td> </tr> <tr> <td>00 1101b = ÷ 16</td> <td>10 0011b = ÷ 56</td> <td>11 1000b = ÷ 176</td> </tr> <tr> <td>00 1110b = ÷ 18</td> <td>10 0100b = ÷ 60</td> <td>11 1001b = ÷ 180</td> </tr> <tr> <td>00 1111b = ÷ 20</td> <td>10 0101b = ÷ 64</td> <td>11 1010b = ÷ 200</td> </tr> <tr> <td>01 0000b = ÷ 21</td> <td>10 0110b = ÷ 66</td> <td>11 1011b = ÷ 220</td> </tr> <tr> <td>01 0001b = ÷ 22</td> <td>10 0111b = ÷ 70</td> <td>11 1100b = Reserved</td> </tr> <tr> <td>01 0010b = ÷ 24</td> <td>10 1000b = ÷ 72</td> <td>11 1101b = Reserved</td> </tr> <tr> <td>01 0011b = ÷ 25</td> <td>10 1001b = ÷ 80</td> <td>11 1110b = Reserved</td> </tr> <tr> <td>01 0100b = ÷ 27</td> <td>10 1010b = ÷ 84</td> <td>11 1111b = Reserved</td> </tr> <tr> <td>01 0101b = ÷ 28</td> <td></td> <td></td> </tr> </table>	00 0000b = Reserved	01 0110b = ÷ 30	10 1011b = ÷ 88	00 0001b = Reserved	01 0111b = ÷ 32	10 1100b = ÷ 90	00 0010b = ÷ 2	01 1000b = ÷ 33	10 1101b = ÷ 96	00 0011b = ÷ 3	01 1001b = ÷ 35	10 1110b = ÷ 100	00 0100b = ÷ 4	01 1010b = ÷ 36	10 1111b = ÷ 108	00 0101b = ÷ 5	01 1011b = ÷ 40	11 0000b = ÷ 110	00 0110b = ÷ 6	01 1100b = ÷ 42	11 0001b = ÷ 112	00 0111b = ÷ 8	01 1101b = ÷ 44	11 0010b = ÷ 120	00 1000b = ÷ 9	01 1110b = ÷ 45	11 0011b = ÷ 128	00 1001b = ÷ 10	01 1111b = ÷ 48	11 0100b = ÷ 132	00 1010b = ÷ 12	10 0000b = ÷ 50	11 0101b = ÷ 140	00 1011b = ÷ 14	10 0001b = ÷ 54	11 0110b = ÷ 144	00 1100b = ÷ 15	10 0010b = ÷ 55	11 0111b = ÷ 160	00 1101b = ÷ 16	10 0011b = ÷ 56	11 1000b = ÷ 176	00 1110b = ÷ 18	10 0100b = ÷ 60	11 1001b = ÷ 180	00 1111b = ÷ 20	10 0101b = ÷ 64	11 1010b = ÷ 200	01 0000b = ÷ 21	10 0110b = ÷ 66	11 1011b = ÷ 220	01 0001b = ÷ 22	10 0111b = ÷ 70	11 1100b = Reserved	01 0010b = ÷ 24	10 1000b = ÷ 72	11 1101b = Reserved	01 0011b = ÷ 25	10 1001b = ÷ 80	11 1110b = Reserved	01 0100b = ÷ 27	10 1010b = ÷ 84	11 1111b = Reserved
00 0000b = Reserved	01 0110b = ÷ 30	10 1011b = ÷ 88																																																																
00 0001b = Reserved	01 0111b = ÷ 32	10 1100b = ÷ 90																																																																
00 0010b = ÷ 2	01 1000b = ÷ 33	10 1101b = ÷ 96																																																																
00 0011b = ÷ 3	01 1001b = ÷ 35	10 1110b = ÷ 100																																																																
00 0100b = ÷ 4	01 1010b = ÷ 36	10 1111b = ÷ 108																																																																
00 0101b = ÷ 5	01 1011b = ÷ 40	11 0000b = ÷ 110																																																																
00 0110b = ÷ 6	01 1100b = ÷ 42	11 0001b = ÷ 112																																																																
00 0111b = ÷ 8	01 1101b = ÷ 44	11 0010b = ÷ 120																																																																
00 1000b = ÷ 9	01 1110b = ÷ 45	11 0011b = ÷ 128																																																																
00 1001b = ÷ 10	01 1111b = ÷ 48	11 0100b = ÷ 132																																																																
00 1010b = ÷ 12	10 0000b = ÷ 50	11 0101b = ÷ 140																																																																
00 1011b = ÷ 14	10 0001b = ÷ 54	11 0110b = ÷ 144																																																																
00 1100b = ÷ 15	10 0010b = ÷ 55	11 0111b = ÷ 160																																																																
00 1101b = ÷ 16	10 0011b = ÷ 56	11 1000b = ÷ 176																																																																
00 1110b = ÷ 18	10 0100b = ÷ 60	11 1001b = ÷ 180																																																																
00 1111b = ÷ 20	10 0101b = ÷ 64	11 1010b = ÷ 200																																																																
01 0000b = ÷ 21	10 0110b = ÷ 66	11 1011b = ÷ 220																																																																
01 0001b = ÷ 22	10 0111b = ÷ 70	11 1100b = Reserved																																																																
01 0010b = ÷ 24	10 1000b = ÷ 72	11 1101b = Reserved																																																																
01 0011b = ÷ 25	10 1001b = ÷ 80	11 1110b = Reserved																																																																
01 0100b = ÷ 27	10 1010b = ÷ 84	11 1111b = Reserved																																																																
01 0101b = ÷ 28																																																																		
			Note: QD1 CMOS output should be powered-off for output frequencies greater than the maximum listed for it in <a href="#">Table 27</a> .																																																															
ND_DIVF[1:0]	R/W	00b	Post-divider Ratio for fractional divider for Bank D: 00 = ÷1 01 = ÷2 10 = ÷4 11 = Reserved																																																															
ND_DIV	R/W	0b	Control which divider is used to provide output frequency for Bank D: 0 = Integer divider D (ND configures this) 1 = Fractional mode (ND_FINT, ND_FRAC and ND_DIVF configure this)																																																															
ND_SRC	R/W	0b	Output Source Selection for Bank D: 0 = Bank D is driven from the integer or fractional divider as selected by ND_DIV 1 = Bank D is driven from the input reference (after the input mux)																																																															

Bank D Control Register Block Field Descriptions			
Bit Field Name <sup>[a]</sup>	Field Type	Default Value	Description
PD_D	R/W	0b	Power-down Bank D: 0 = Bank D and all QD outputs powered and operate normally. 1 = Bank D and all QD outputs powered-down. QD1 output is in High-Impedance. When powering-down the output Bank, it is recommended to also write a 1 to the PD_QDx registers.
ND_CTL	R/W	0b	Bank D Configuration Control: 0 = ND[5:0], ND_FRAC[23:0], ND_FINT[3:0], ND_DIVF[1:0], ND_DIV, ND_SRC, PD_D, and PD_QD1 settings are determined by ND[1:0] control pins. 1 = ND[5:0], ND_FRAC[23:0], ND_FINT[3:0], ND_DIVF[1:0], ND_DIV, ND_SRC, PD_D, and PD_QD1 settings are determined by register settings over I <sup>2</sup> C.
PD_QDx	R/W	0b	Power-down Output QDx: 0 = QDx outputs powered and operate normally. 1 = QD0 output powered-down.
Rsvd	R/W	-	Reserved. Always write 0 to this bit location. Read values are not defined.

[a] Where x = 0 or 1.

**Table 17. Device Control Register Bit Field Locations and Descriptions**

Device Control Register Block Field Locations								
Address (Hex)	D7	D6	D5	D4	D3	D2	D1	D0
3D	INIT_CLK	Rsvd						
3E	RELOCK	Rsvd						
3F	PB_CAL	Rsvd						
40	Rsvd				EN_A	EN_B	EN_C	EN_D

Device Control Register Block Field Descriptions			
Bit Field Name	Field Type	Default Value	Description
INIT_CLK	W/O <sup>[a]</sup>	0b	Writing a 1 to this bit location will cause output dividers to be synchronized. Must be done every time a divider value is changed. This bit will auto-clear.
RELOCK	W/O <sup>[a]</sup>	0b	Writing a 1 to this bit location will cause the PLL to re-lock. This bit will auto-clear.
PB_CAL	W/O <sup>[a]</sup>	0b	Precision Bias Calibration: Setting this bit to 1 will start the calibration of an internal precision bias current source. The bias current is used as reference for outputs configured as reference for the charge pump currents. This bit will auto-clear.
EN_A	R/W	1b	Output Enable Control for Bank A: 0 = Bank A outputs QA[0:3] disabled to logic-low state (QAx = 0, nQAx = 1) 1 = Bank A outputs QA[0:3] enabled
EN_B	R/W	1b	Output Enable Control for Bank B: 0 = Bank B outputs QB[0:3] disabled to logic-low state (QBx = 0, nQBx = 1) 1 = Bank B outputs QB[0:3] enabled
EN_C	R/W	1b	Output Enable Control for Bank C: 0 = Bank C outputs QC[0:1] disabled to logic-low state (QCx = 0, nQCx = 1) 1 = Bank C outputs QC[0:1] enabled
EN_D	R/W	1b	Output Enable Control for Bank D: 0 = Bank D outputs QD[0:1] disabled to logic-low state (QD0 = 0, nQD0 = 1, QD1 = 0) 1 = Bank D outputs QD[0:1] enabled Note: If Bank D is powered down via the PD_D bit or the QD1 output is powered down by the PD_QD1 bit, then QD1 will be in High-Impedance regardless of the state of this bit.
Rsvd	R/W	-	Reserved. Always write 0 to this bit location. Read values are not defined.

[a] These bits are read as 0. When a 1 is written to them, it will have the indicated effect and then self-clear back to 0.

## Absolute Maximum Ratings

The absolute maximum ratings are stress ratings only. Stresses greater than those listed below can cause permanent damage to the device. Functional operation of the 8V41NS0412 at absolute maximum ratings is not implied. Exposure to absolute maximum rating conditions may affect device reliability.

**Table 18. Absolute Maximum Ratings**

Item	Rating
Supply Voltage, $V_{DD}$	3.6V
Inputs, $V_I$	
OSCI	-0.5V to 3.6V
Other Inputs	-0.5V to 3.6V
Outputs, $V_O$ (LVCMOS)	-0.5V to 3.6V
Outputs, $V_O$ (HCSL)	-0.5V to $V_{DD} + 0.5V$
Maximum Junction Temperature, $t_{JMAX}$	125°C
Storage Temperature, $T_{STG}$	-65°C to 150°C

## DC Electrical Characteristics

**Table 19. Input Characteristics**

Symbol	Parameter	Test Conditions	Minimum	Typical	Maximum	Units
$C_{IN}$	Input Capacitance <sup>[a]</sup>			3.5		pF
$R_{PULLDOWN}$	Input Pulldown Resistor			51		kΩ
$R_{PULLUP}$	Input Pullup Resistor			51		kΩ

[a] This specification does not apply to OSCI and OSCO pins.

**Table 20. Output Characteristics**

Symbol	Parameter		Test Conditions	Minimum	Typical	Maximum	Units
$R_{OUT}$	Output Impedance	LOCK	$V_{DD}^{[a]} = 3.3V$		20		W
		QD1			30		W

[a]  $V_{DD}$  denotes  $V_{DD\_SP}$ ,  $V_{DDOD}$ .

**Table 21. Power Supply DC Characteristics,  $V_{DD\_X}^{[a]} = V_{DDOX}^{[b]} = 3.3V \pm 5\%$ ,  $T_A = -40^\circ C$  to  $+85^\circ C$**

Symbol	Parameter	Test Conditions	Minimum	Typical	Maximum	Units
$V_{DD\_X}$	Core Supply Voltage		3.135	3.3	3.465	V
$V_{DDA\_X}^{[c]}$	Analog Supply Voltage		3.135	3.3	3.465	V
$V_{DDOX}$	Output Supply Voltage		3.135	3.3	3.465	V
$I_{DD\_X}^{[d]}$	Core Supply Current			90	110	mA
$I_{DDA\_X}^{[e]}$	Analog Supply Current			138	165	mA
$I_{DDOX}^{[f][g]}$	Output Supply Current	All differential outputs are enabled but not loaded <sup>[h]</sup>		225	265	mA
		All differential outputs are enabled but not loaded – QD1 output is powered down		200	235	mA

[a]  $V_{DD\_X}$  denotes  $V_{DD\_CP}$ ,  $V_{DD\_CK}$ ,  $V_{DD\_SP}$ .

[b]  $V_{DDOX}$  denotes  $V_{DDOA}$ ,  $V_{DDOB}$ ,  $V_{DDOC}$ ,  $V_{DDOD}$ .

[c]  $V_{DDA\_X}$  denotes  $V_{DDA\_IN1}$ ,  $V_{DDA\_IN2}$ ,  $V_{DDA}$ ,  $V_{DDA\_XT}$ .

[d]  $I_{DD\_X}$  denotes  $I_{DD\_CP}$ ,  $I_{DD\_CK}$ ,  $I_{DD\_SP}$ .

[e]  $I_{DDA\_X}$  denotes  $I_{DDA\_IN1}$ ,  $I_{DDA\_IN2}$ ,  $I_{DDA}$ ,  $I_{DDA\_XT}$ .

[f] Internal maximum dynamic switching current is included.

[g]  $I_{DDOX}$  denotes  $I_{DDOA}$ ,  $I_{DDOB}$ ,  $I_{DDOC}$ ,  $I_{DDOD}$ .

[h] QD1 output is terminated with  $50\Omega$  to  $V_{DDOX}/2$ .

**Table 22. LVCMOS DC Characteristics for 3-level Pins,  $V_{DD\_X}^{[a]} = V_{DDOX}^{[b]} = 3.3V \pm 5\%$ ,  $T_A = -40^\circ C$  to  $+85^\circ C$**

Symbol	Parameter	Test Conditions	Minimum	Typical	Maximum	Units
$V_{IH}$	Input High Voltage	FIN[1:0], NA[1:0], NB[1:0], NC[1:0], ND[1:0]	$0.7 \times V_{DD}^{[c]}$		3.465	V
$V_{IM}$	Input Middle Voltage		$0.4 \times V_{DD}^{[c]}$		$0.6 \times V_{DD}^{[c]}$	V
$V_{IL}$	Input Low Voltage		-0.3		$0.3 \times V_{DD}^{[c]}$	V
$I_{IH}$	Input High Current	FIN[1:0], NA[1:0], NB[1:0], NC[1:0], ND[1:0]	$V_{DD}^{[c]} = V_{IN} = 3.465V$		150	$\mu A$
$I_{IM}$	Input Middle Current	FIN[1:0], NA[1:0], NB[1:0], NC[1:0], ND[1:0]	$V_{IN} = V_{DD}^{[c]} / 2$		$\pm 1$	$\mu A$
$I_{IL}$	Input Low Current	FIN[1:0], NA[1:0], NB[1:0], NC[1:0], ND[1:0]	$V_{DD}^{[c]} = 3.465V$ , $V_{IN} = 0V$		-150	$\mu A$

[a]  $V_{DD\_X}$  denotes  $V_{DD\_CP}$ ,  $V_{DD\_CK}$ ,  $V_{DD\_SP}$ .

[b]  $V_{DDOX}$  denotes  $V_{DDOA}$ ,  $V_{DDOB}$ ,  $V_{DDOC}$ ,  $V_{DDOD}$ .

[c]  $V_{DD}$  denotes  $V_{DDA\_IN1}$ ,  $V_{DD\_CK}$ .

**Table 23. LVCMOS DC Characteristics for 2-level Pins,  $V_{DD\_X}^{[a]} = V_{DDOX}^{[b]} = 3.3V \pm 5\%$ ,  $T_A = -40^\circ C$  to  $+85^\circ C$**

Symbol	Parameter		Test Conditions	Minimum	Typical	Maximum	Units
$V_{IH}$	Input High Voltage			$0.7 \times V_{DD}^{[c]}$		3.465	V
$V_{IL}$	Input Low Voltage	REF_SEL		-0.3		$0.3 \times V_{DD}^{[c]}$	V
		SDATA, SCLK		-0.3		$0.15 \times V_{DD}^{[c]}$	V
$I_{IH}$	Input High Current	SCLK, SDATA	$V_{DD}^{[c]} = V_{IN} = 3.465V$			5	$\mu A$
		REF_SEL	$V_{DD}^{[c]} = V_{IN} = 3.465V$			150	$\mu A$
$I_{IL}$	Input Low Current	SCLK, SDATA	$V_{DD}^{[c]} = 3.465V, V_{IN} = 0V$	-150			$\mu A$
		REF_SEL	$V_{DD}^{[c]} = 3.465V, V_{IN} = 0V$	-5			$\mu A$
$V_{OH}$	Output High Voltage	LOCK	$I_{OH} = -4mA$	2.2			V
$V_{OL}$	Output Low Voltage	SDATA, LOCK	$I_{OL} = 4mA$			0.45	V

[a]  $V_{DD\_X}$  denotes  $V_{DD\_CP}, V_{DD\_CK}, V_{DD\_SP}$ .

[b]  $V_{DDOX}$  denotes  $V_{DDOA}, V_{DDOB}, V_{DDOC}, V_{DDOD}$ .

[c]  $V_{DD}$  denotes  $V_{DD\_CK}, V_{DD\_SP}$ .

**Table 24. Differential Input DC Characteristics,  $V_{DD\_X}^{[a]} = V_{DDOX}^{[b]} = 3.3V \pm 5\%$ ,  $T_A = -40^\circ C$  to  $+85^\circ C$**

Symbol	Parameter		Test Conditions	Minimum	Typical	Maximum	Units
$I_{IH}$	Input High Current	CLK_IN, nCLK_IN	$V_{DD}^{[c]} = V_{IN} = 3.465V$			150	$\mu A$
$I_{IL}$	Input Low Current	CLK_IN	$V_{DD}^{[c]} = 3.465V, V_{IN} = 0V$	-5			$\mu A$
		nCLK_IN	$V_{DD}^{[c]} = 3.465V, V_{IN} = 0V$	-150			$\mu A$
$V_{PP}$	Peak-to-peak Voltage <sup>[d], [e]</sup>	CLK_IN, nCLK_IN		0.2		1.4	V
$V_{CMR}$	Common Mode Input Voltage <sup>[d][e]</sup>	CLK_IN, nCLK_IN		GND + 1.1		$V_{DD}^{[c]} - 0.3$	V

[a]  $V_{DD\_X}$  denotes  $V_{DD\_CP}, V_{DD\_CK}, V_{DD\_SP}$ .

[b]  $V_{DDOX}$  denotes  $V_{DDOA}, V_{DDOB}, V_{DDOC}, V_{DDOD}$ .

[c]  $V_{DD}$  denotes  $V_{DD\_CK}$ .

[d] Common mode voltage is defined as the cross point.

[e] Input voltage cannot be less than GND – 300mV or more than  $V_{DD}$ .

**Table 25. LVC MOS DC Characteristics for QD1 Output,  $V_{DD\_x}^{[a]} = V_{DD0D} = 3.3V \pm 5\%$**

Symbol	Parameter	Test Conditions	Minimum	Typical	Maximum	Units
$V_{OH}$	Output High Voltage	QD1, $I_{OH} = -8mA$	2.6			V
$V_{OL}$	Output Low Voltage	QD1, $I_{OL} = 8mA$			0.5	V

[a]  $V_{DD\_x}$  denotes  $V_{DD\_CP}$ ,  $V_{DD\_CK}$ ,  $V_{DD\_SP}$ .

**Table 26. Crystal Characteristics**

Parameter	Test Conditions	Minimum	Typical	Maximum	Units
Mode of Oscillation		Fundamental			
Frequency		10		50	MHz
Equivalent Series Resistance (ESR)	> 32 MHz			30	$\Omega$
	$\leq 32$ MHz			50	
Load Capacitance ( $C_L$ )	50MHz Crystal		8	12	pF
	25MHz Crystal		12	22	
Shunt Capacitance	> 32 MHz			3	pF
	$\leq 32$ MHz			7	pF
Maximum Crystal Drive Level			200		$\mu W$
Frequency Stability (total)		-100		100	ppm

## AC Electrical Characteristics

**Table 27. AC Characteristics<sup>[a]</sup>  $V_{DD\_X}^{[b]} = V_{DDOX}^{[c]} = 3.3V +5\%$ ,  $T_A = -40^{\circ}C$  to  $+85^{\circ}C$**

Symbol	Parameter		Test Conditions	Minimum	Typical	Maximum	Units	
$f_{VCO}$	VCO Frequency			2400		2500	MHz	
$f_{PFD}$	Phase / Frequency Detector Frequency			5		200	MHz	
$f_{OUT}$	Output Frequency	QA[0:3] nQA[0:3] QB[0:3] nQB[0:3] QC[0:1] nQC[0:1]		10.91		1250	MHz	
		QD0, nQD0	Integer divider selected	10.91		1250	MHz	
			Fractional divider selected	20		250	MHz	
		QD1	Integer divider selected	10.91		250	MHz	
			Fractional divider selected	20		250	MHz	
$t_{sk(b)}$	Bank Skew <sup>[d][e][f]</sup>	Bank A				45	ps	
		Bank B				45		
		Bank C				20		
$t_R / t_F$	Output Rise/Fall Time	QA[0:3] nQA[0:3] QB[0:3] nQB[0:3] QC[0:1] nQC[0:1] QD0, nQD0	20% to 80%			325	ps	
		QD1	20% to 80%		700	1100		
odc	Output Duty Cycle <sup>[g]</sup>	QA[0:3] nQA[0:3] QB[0:3] nQB[0:3] QC[0:1] nQC[0:1], QD0, nQD0		45	50	55	%	
		QD1	$F_{OUT} < 156.25MHz$	45	50	55		%
			$F_{OUT} \geq 156.25MHz$	40	50	60		%
$t_{LOCK}$	PLL Lock Time <sup>[h]</sup>				10		ms	

[a] Electrical parameters are guaranteed over the specified ambient operating temperature range, which is established when the device is mounted in a test socket with maintained transverse airflow greater than 500lpm. The device will meet specifications after thermal equilibrium has been reached under these conditions.

[b]  $V_{DD\_X}$  denotes  $V_{DD\_CP}$ ,  $V_{DD\_CK}$ ,  $V_{DD\_SP}$ .

[c]  $V_{DDOX}$  denotes  $V_{DDOA}$ ,  $V_{DDOB}$ ,  $V_{DDOC}$ ,  $V_{DDOD}$ .

[d] Defined as skew among outputs from same bank at the same supply voltage with equal load conditions. Measured at the output differential crosspoints.

[e] This parameter is defined in accordance with JEDEC Standard 65.

[f] This parameter is guaranteed by characterization. Not tested in production

[g] Duty cycle of bypassed signals (input reference clock or crystal input) is not adjusted by the device.

[h] PLL lock time is defined as time from input clock availability to frequency locked output. The following loop filter component values can be used:  
 $R_Z = 150\Omega$ ,  $C_Z = 0.1\mu F$   $C_P = 200pF$ . For more information, see [Applications Information](#).

**Table 28. Qmn<sup>[a]</sup> and QD1 Phase Noise and Jitter Characteristics,  $V_{DD\_X}^{[b]} = V_{DDOX}^{[c]} = 3.3V+5\%$ ,  $T_A = -40^\circ C$  to  $+85^\circ C$ <sup>[d][e][f][g]</sup>**

Symbol	Parameter		Test Conditions	Minimum	Typical	Maximum	Units
fjit(∅)	RMS Phase Jitter random	Qmn = 156.25MHz	Integration range: 12kHz – 20MHz		80	95	fs
	RMS Phase Jitter random	Qmn = 125MHz	Integration range: 12kHz – 20MHz		81		fs
	RMS Phase Jitter random	Qmn = 100MHz	Integration range: 12kHz – 20MHz		105		fs
	RMS Phase Jitter random	Qmn = 25MHz	Integration range: 12kHz – 5MHz		172		fs
	RMS Phase Jitter random	QD0 = 133.3333MHz (fractional) <sup>[h]</sup>	Integration range: 12kHz – 20MHz		115		fs
	RMS Phase Jitter random	QD1= 125MHz	Integration range: 12kHz – 20MHz		170		fs
	RMS Phase Jitter random <sup>[i]</sup>	QAn = 156.25MHz	Integration range: 12kHz – 20MHz		110		fs
		QBn = 100MHz	Integration range: 12kHz – 20MHz		120		fs
		QCn = 25MHz	Integration range: 12kHz – 5MHz		172		fs
		QD0 = 133.3333MHz (fractional)	Integration range: 12kHz – 20MHz		115		fs
$\Phi_N(10)$	Single-side Band Noise Power, 10Hz from carrier		Qmn = 156.25MHz		-78		dBc/Hz
$\Phi_N(100)$	Single-side Band Noise Power, 100Hz from carrier		Qmn = 156.25MHz		-115.4		dBc/Hz
$\Phi_N(1k)$	Single-side Band Noise Power, 1kHz from carrier		Qmn = 156.25MHz		-130.5		dBc/Hz
$\Phi_N(10k)$	Single-side Band Noise Power, 10kHz from carrier		Qmn = 156.25MHz		-137.6		dBc/Hz
$\Phi_N(100k)$	Single-side Band Noise Power, 100kHz from carrier		Qmn = 156.25MHz		-143.6		dBc/Hz
$\Phi_N(1M)$	Single-side Band Noise Power, 1MHz from carrier		Qmn = 156.25MHz		-154.7		dBc/Hz
$\Phi_N(10M)$	Single-side Band Noise Power, 10MHz from carrier		Qmn = 156.25MHz		-162		dBc/Hz
$\Phi_N(\infty)$	Noise Floor ( $\geq 30MHz$ from carrier)		Qmn = 156.25MHz		-162.1		dBc/Hz

[a] Qmn denotes the differential outputs QA[0:3], QB[0:3], QC[0:1] or QD0.

[b]  $V_{DD\_x}$  denotes  $V_{DD\_CP}$ ,  $V_{DD\_CK}$ ,  $V_{DD\_SP}$ .

[c]  $V_{DDOX}$  denotes  $V_{DDOA}$ ,  $V_{DDOB}$ ,  $V_{DDOC}$ ,  $V_{DDOD}$ .

[d] Electrical parameters are guaranteed over the specified ambient operating temperature range, which is established when the device is mounted in a test socket with maintained transverse airflow greater than 500lfpm. The device will meet specifications after thermal equilibrium has been reached under these conditions.

[e] All outputs enabled and configured for the same output frequency unless otherwise noted.

[f] Characterized using a 50MHz crystal unless otherwise noted.

[g] The following loop filter component values were used:  $R_Z = 150\Omega$ ,  $C_Z = 0.1\mu F$ ,  $CP = 200pF$ . PLL charge pump current control set at 5.2mA.

[h]  $QAx = 156.25MHz$ ,  $QBx = 156.25MHz$ ,  $QCx = 156.25MHz$  and  $QD1 = OFF$ .

[i]  $QAx = 156.25MHz$ ,  $QBx = 100MHz$ ,  $QCx = 25MHz$ ,  $QD0 = 133.3333MHz$  (fractional) and  $QD1 = OFF$ .

**Table 29. HCSL AC Characteristics<sup>[a]</sup>  $V_{DD\_x}^{[b]} = V_{DDOX}^{[c]} = 3.3V+5%$ ,  $T_A = -40^\circ C$  to  $+85^\circ C$**

Symbol	Parameter	Test Conditions	Minimum	Typical	Maximum	Units
$V_{RB}$	Ring-Back Voltage Margin <sup>[d]</sup> [e]	Q[A:D], nQ[A:D]	-100		100	mV
$t_{STABLE}$	Time before $V_{RB}$ is allowed <sup>[d]</sup> [e]	Q[A:D], nQ[A:D]	500			ps
$V_{MAX}$	Absolute Max Output Voltage <sup>[f]</sup> [g]	Q[A:D], nQ[A:D]			1150	mV
$V_{MIN}$	Absolute Min output voltage <sup>[f]</sup> [h]	Q[A:D], nQ[A:D]	-300			mV
$V_{CROSS}$	Absolute Crossing voltage <sup>[f]</sup> [i] [j]	Q[A:D], nQ[A:D]	200		550	mV
$\Delta V_{CROSS}$	Total Variation of $V_{CROSS}$ over all edges <sup>[f]</sup> [k]	Q[A:D], nQ[A:D]			140	mV
$t_{SLEW+}$	Rising Edge Rate <sup>[d]</sup> [l]	Q[A:D], nQ[A:D]	1.3		6.8	V/ns
$t_{SLEW-}$	Falling Edge Rate <sup>[d]</sup> [l]	Q[A:D], nQ[A:D]	1.3		6.8	V/ns

[a] Electrical parameters are guaranteed over the specified ambient operating temperature range, which is established when the device is mounted in a test socket with maintained transverse airflow greater than 500lfpm. The device will meet specifications after thermal equilibrium has been reached under these conditions.

[b]  $V_{DD\_x}$  denotes  $V_{DD\_CP}$ ,  $V_{DD\_CK}$ ,  $V_{DD\_SP}$ .

[c]  $V_{DDOX}$  denotes  $V_{DDOA}$ ,  $V_{DDOB}$ ,  $V_{DDOC}$ ,  $V_{DDOD}$ .

[d] Measurement taken from differential waveform.

[e]  $t_{STABLE}$  is the time the differential clock must maintain a minimum  $\pm 150mV$  differential voltage after rising/falling edges before it is allowed to drop back into the  $V_{RB} \pm 100mV$  range.

[f] Measurement taken from single-ended waveform.

[g] Defined as the maximum instantaneous voltage including overshoot.

[h] Defined as the minimum instantaneous voltage including undershoot.

[i] Measured at the crossing point where the instantaneous voltage value of the rising edge of Q[Ax:Dx] equals the falling edge of nQ[Ax:Dx].

[j] Refers to the total variation from the lowest crossing point to the highest, regardless of which edge is crossing. Refers to all crossing points for this measurement.

- [k] Defined as the total variation of all crossing voltages of rising Q[Ax:Dx] and falling nQ[Ax:Dx]. This is the maximum allowed variance in  $V_{cross}$  for any particular system.
- [l] Measured from -150mV to +150mV on the differential waveform (derived from Q[Ax:Dx] minus nQ[Ax:Dx]). The signal must be monotonic through the measurement region for rise and fall time. The 300mV measurement window is centered on the differential zero crossing.

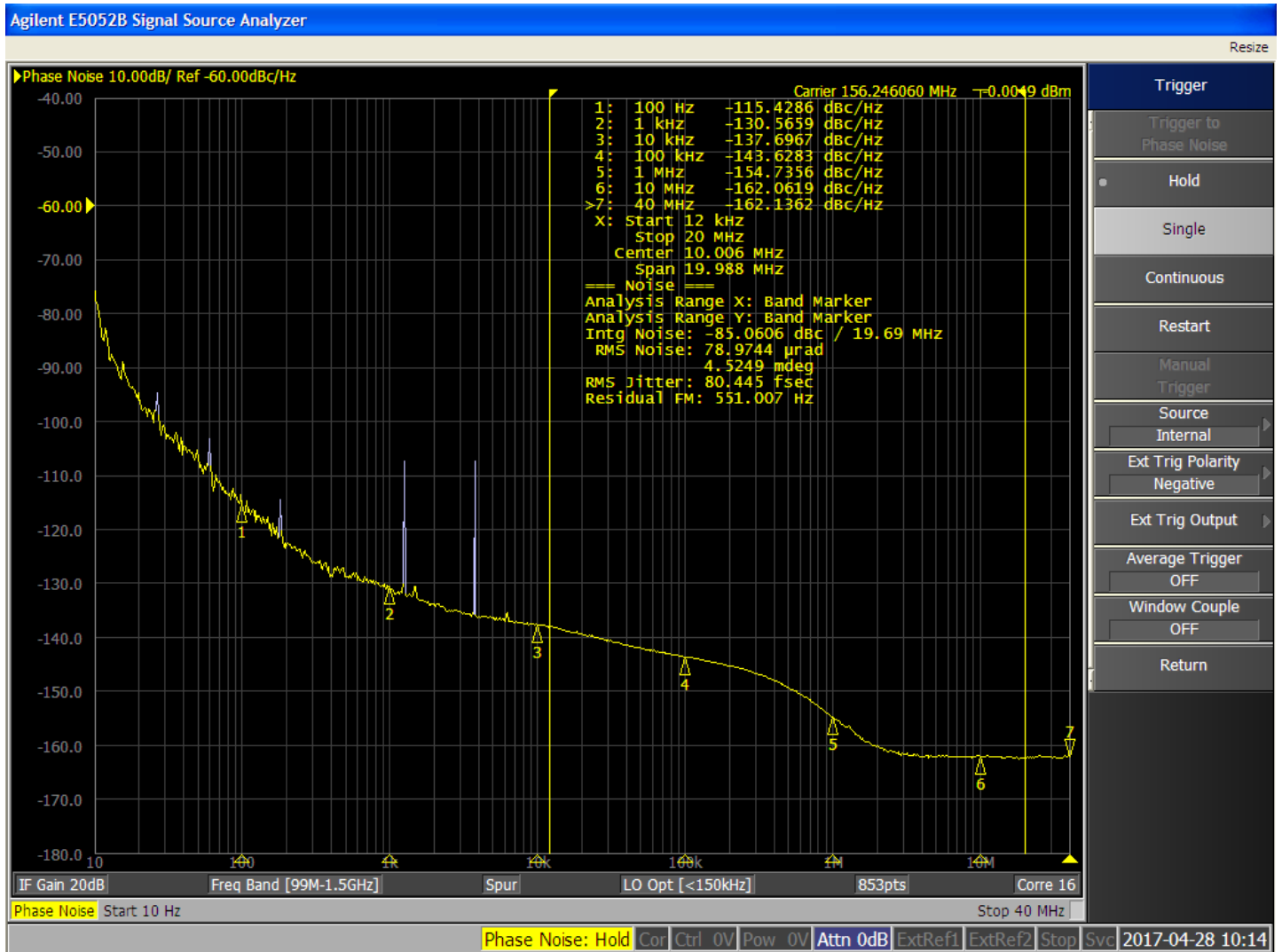
**Table 30. PCI Express Jitter Specifications, <sup>[a]</sup>  $V_{DD\_X}$  <sup>[b]</sup> =  $V_{DDOX}$  <sup>[c]</sup> = 3.3V +5%,  $T_A$  = -40°C to +85°C**

Symbol	Parameter	Test Conditions <sup>[d]</sup>	Minimum	Typical	Maximum	PCIe Industry Specification	Units
$t_j$ (PCIe Gen 1)	Phase Jitter Peak-to-peak <sup>[e]</sup> <sup>[f]</sup>	Evaluation Band: 0Hz – Nyquist (clock frequency/2)		6.1		86	ps
$t_{REFCLK\_HF\_RMS}$ (PCIe Gen 2)	Phase Jitter, RMS <sup>[f]</sup> <sup>[g]</sup>	High Band: 1.5MHz – Nyquist (clock frequency/2)		0.4		3.10	ps
$t_{REFCLK\_LF\_RMS}$ (PCIe Gen 2)	Phase Jitter, RMS <sup>[f]</sup> <sup>[g]</sup>	Low Band: 10kHz – 1.5MHz		0.13		3.0	ps
$t_{REFCLK\_RMS}$ (PCIe Gen 3)	Phase Jitter, RMS <sup>[f]</sup> <sup>[h]</sup>	Evaluation Band: 0Hz – Nyquist (clock frequency/2)		0.08		0.8	ps

- [a] Electrical parameters are guaranteed over the specified ambient operating temperature range, which is established when the device is mounted in a test socket with maintained transverse airflow greater than 500lfpm. The device will meet specifications after thermal equilibrium has been reached under these conditions.
- [b]  $V_{DD\_X}$  denotes  $V_{DD\_CP}$ ,  $V_{DD\_CK}$ ,  $V_{DD\_SP}$ .
- [c]  $V_{DDOX}$  denotes  $V_{DDOA}$ ,  $V_{DDOB}$ ,  $V_{DDOC}$ ,  $V_{DDOD}$ .
- [d]  $f = 100\text{MHz}$ , 50MHz Crystal input and Doubler is ON (FDP = 1)
- [e] Peak-to-Peak jitter after applying system transfer function for the Common Clock Architecture. Maximum limit for PCI Express Gen 1 is 86ps peak-to-peak for a sample size of  $10^6$  clock periods.
- [f] This parameter is guaranteed by characterization. Not tested in production.
- [g] RMS jitter after applying the two evaluation bands to the two transfer functions defined in the Common Clock Architecture and reporting the worst case results for each evaluation band. Maximum limit for PCI Express Generation 2 is 3.1ps RMS for  $t_{REFCLK\_HF\_RMS}$  (High Band) and 3.0ps RMS for  $t_{REFCLK\_LF\_RMS}$  (Low Band).
- [h] RMS jitter after applying system transfer function for the common clock architecture. This specification is based on the *PCI Express Base Specification Revision 0.7, October 2009* and is subject to change pending the final release version of the specification.

# Phase Noise Plots

Figure 4. Typical Phase Noise at 156.25MHz



**Figure 5. Typical Phase Noise at 125MHz**



## Applications Information

### Recommendations for Unused Input and Output Pins

#### Inputs

##### LVC MOS Control Pins

All control pins have internal pull-up and/or pull-down resistors; additional resistance is not required but can be added for additional protection. A 1kΩ resistor can be used.

#### Outputs

##### HCSL Outputs

All unused differential outputs can be left floating. We recommended that there is no trace attached.

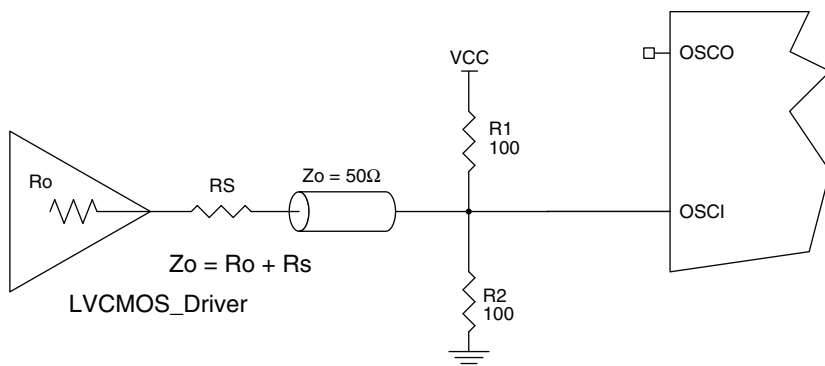
##### LVC MOS Output

QD1 output can be left floating if unused. There should be no trace attached.

### Overdriving the XTAL Interface

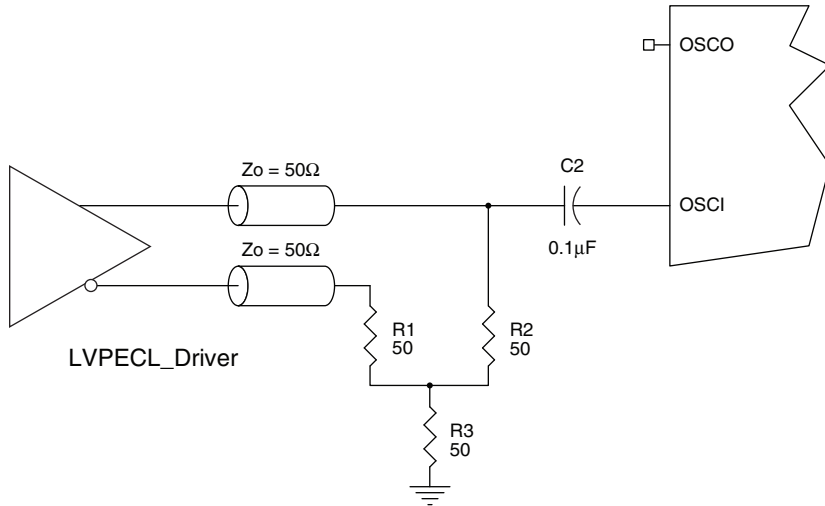
The OSC I input can be overdriven by an LVC MOS driver or by one side of a differential driver through an AC coupling capacitor. The OSC O pin can be left floating. The amplitude of the input signal should be between 500mV and 1.8V and the slew rate should not be less than 0.2V/ns. For 3.3V LVC MOS inputs, the amplitude must be reduced from full swing to at least half the swing in order to prevent signal interference with the power rail and to reduce internal noise. [Figure 6](#) shows an example of the interface diagram for a high speed 3.3V LVC MOS driver. This configuration requires that the sum of the output impedance of the driver ( $R_o$ ) and the series resistance ( $R_s$ ) equals the transmission line impedance. In addition, matched termination at the crystal input will attenuate the signal in half. This can be done in one of two ways. First,  $R_1$  and  $R_2$  in parallel should equal the transmission line impedance. For most 50Ω applications,  $R_1$  and  $R_2$  can be 100Ω. This can also be accomplished by removing  $R_1$  and changing  $R_2$  to 50Ω. The values of the resistors can be increased to reduce the loading for a slower and weaker LVC MOS driver.

**Figure 6. LVC MOS Driver to XTAL Input Interface**



[Figure 7](#) shows an example of the interface diagram for an LVPECL driver. This is a standard LVPECL termination with one side of the driver feeding the OSC I input. It is recommended that all components in the schematics be placed in the layout. Though some components might not be used, they can be utilized for debugging purposes. The datasheet specifications are characterized and guaranteed by using a quartz crystal as the input.

**Figure 7. LVPECL Driver to XTAL Input Interface**

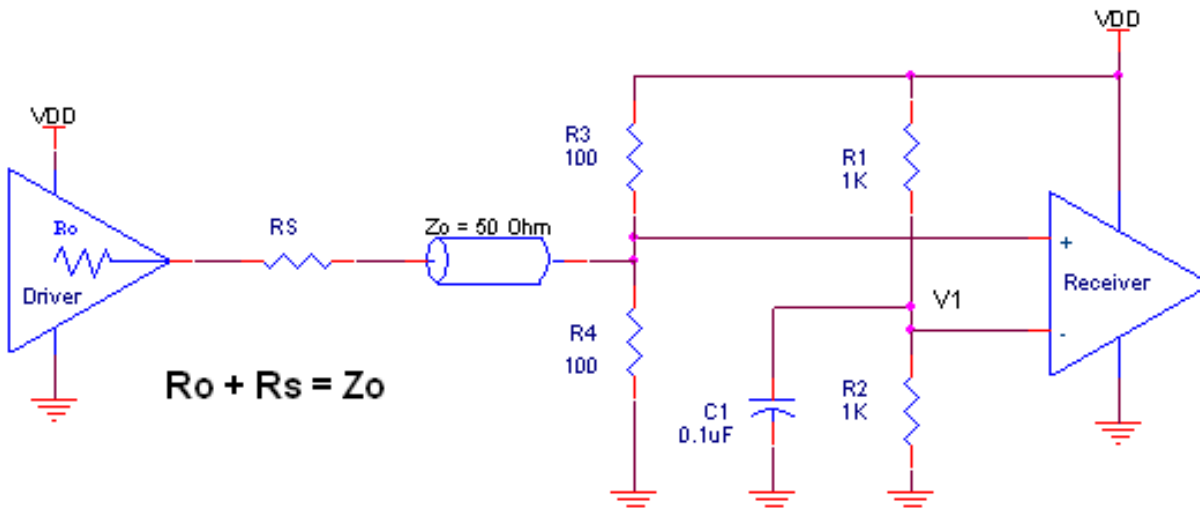


**Wiring the Differential Input to Accept Single-Ended Levels**

Figure 8 shows how a differential input can be wired to accept single ended levels. The reference voltage  $V_1 = V_{DD}/2$  is generated by the bias resistors R1 and R2. The bypass capacitor (C1) is used to help filter noise on the DC bias. This bias circuit should be located as close to the input pin as possible. The ratio of R1 and R2 might need to be adjusted to position the  $V_1$  in the center of the input voltage swing. For example, if the input clock swing is 2.5V and  $V_{DD} = 3.3V$ , R1 and R2 value should be adjusted to set  $V_1$  at 1.25V. The values below are for when both the single ended swing and  $V_{DD}$  are at the same voltage.

This configuration requires that the sum of the output impedance of the driver ( $R_o$ ) and the series resistance ( $R_s$ ) equals the transmission line impedance. In addition, matched termination at the input will attenuate the signal in half. This can be done in one of two ways. First, R3 and R4 in parallel should equal the transmission line impedance. For most 50Ω applications, R3 and R4 can be 100Ω. The values of the resistors can be increased to reduce the loading for slower and weaker LVCMOS driver. When using single-ended signaling, the noise rejection benefits of differential signaling are reduced. Even though the differential input can handle full rail LVCMOS signaling, it is recommended that the amplitude be reduced. The datasheet specifies a lower differential amplitude, however this only applies to differential signals. For single-ended applications, the swing can be larger, however  $V_{IL}$  cannot be less than -0.3V and  $V_{IH}$  cannot be more than  $V_{DD} + 0.3V$ . Suggested edge rate faster than 1V/ns. Though some of the recommended components might not be used, the pads should be placed in the layout. They can be utilized for debugging purposes. The datasheet specifications are characterized and guaranteed by using a differential signal.

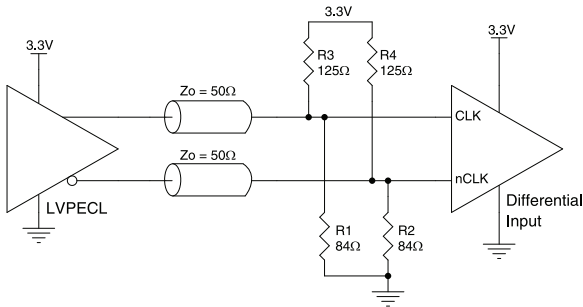
**Figure 8. Recommended Schematic for Wiring a Differential Input to Accept Single-ended Levels**



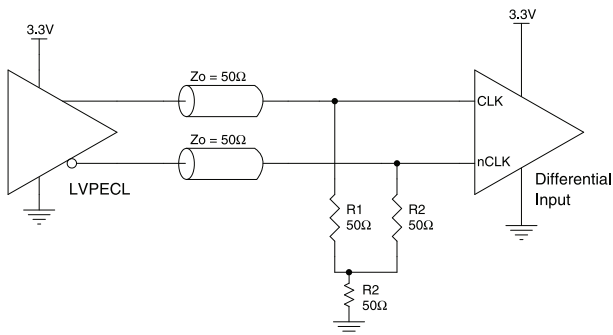
### 3.3V Differential Clock Input Interface

CLK/nCLK accepts LVDS, LVPECL and other differential signals. Both  $V_{SWING}$  and  $V_{OX}$  must meet the  $V_{PP}$  and  $V_{CMR}$  input requirements. Figure 9 to Figure 11 show interface examples for the CLK/nCLK input driven by the most common driver types. The input interfaces suggested here are examples of direct-coupled termination only.

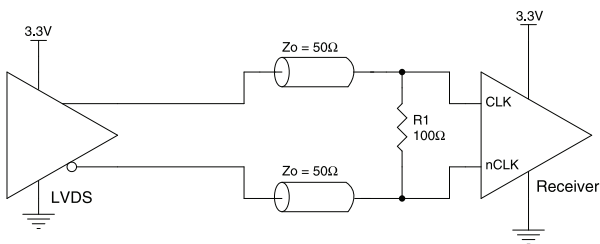
**Figure 9. CLK/nCLK Input Driven by a 3.3V LVPECL Driver**



**Figure 10. CLK/nCLK Input Driven by a 3.3V LVPECL Driver**



**Figure 11. CLK/nCLK Input Driven by a 3.3V LVDS Driver**



## Recommended Termination

Figure 12 is the recommended source termination for applications where the driver and receiver will be on a separate PCBs. This termination is the standard for PCI Express™ and HCSL output types. All traces should be 50Ω impedance single-ended or 100Ω differential.

**Figure 12. Recommended Source Termination (Where the Driver and Receiver will be on Separate PCBs)**

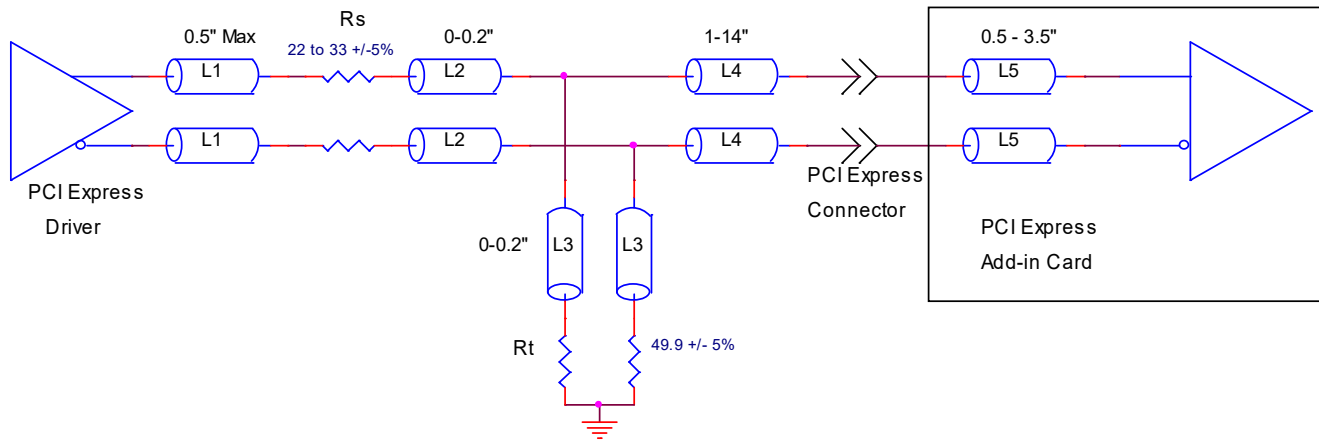
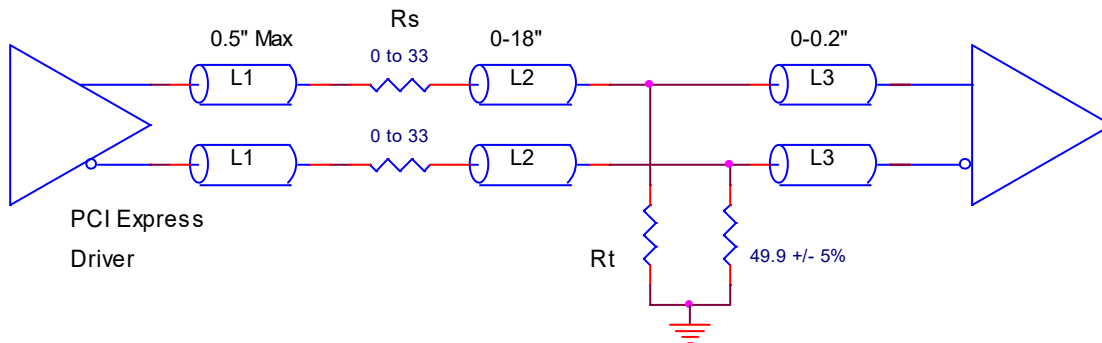


Figure 13 is the recommended termination for applications where a point-to-point connection can be used. A point-to-point connection contains both the driver and the receiver on the same PCB. With a matched termination at the receiver, transmission-line reflections will be minimized. In addition, a series resistor (Rs) at the driver offers flexibility and can help dampen unwanted reflections. The optional resistor can range from 0Ω to 33Ω. All traces should be 50Ω impedance single-ended or 100Ω differential.

**Figure 13. Recommended Termination (Where a Point-to-Point Connection can be used)**



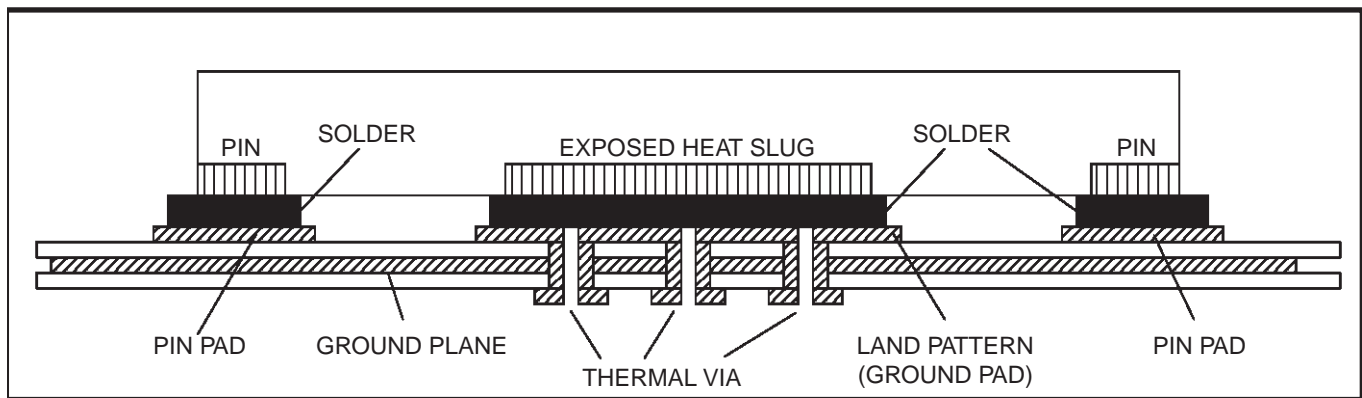
### VFQFN EPAD Thermal Release Path

In order to maximize both the removal of heat from the package and the electrical performance, a land pattern must be incorporated on the Printed Circuit Board (PCB) within the footprint of the package corresponding to the exposed metal pad or exposed heat slug on the package, as shown in Figure 14. The solderable area on the PCB, as defined by the solder mask, should be at least the same size/shape as the exposed pad/slug area on the package to maximize the thermal/electrical performance. Sufficient clearance should be designed on the PCB between the outer edges of the land pattern and the inner edges of pad pattern for the leads to avoid any shorts.

While the land pattern on the PCB provides a means of heat transfer and electrical grounding from the package to the board through a solder joint, thermal vias are necessary to effectively conduct from the surface of the PCB to the ground plane(s). The land pattern must be connected to ground through these vias. The vias act as “heat pipes”. The number of vias (i.e. “heat pipes”) are application specific and dependent upon the package power dissipation as well as electrical conductivity requirements. Thus, thermal and electrical analysis and/or testing are recommended to determine the minimum number needed. Maximum thermal and electrical performance is achieved when an array of vias is incorporated in the land pattern. Renesas recommends to use as many vias connected to ground as possible. It also recommends that the via diameter should be 12 to 13 mils (0.30 to 0.33 mm) with 1oz copper via barrel plating. This is desirable to avoid any solder wicking inside the via during the soldering process which may result in voids in solder between the exposed pad/slug and the thermal land. Precautions should be taken to eliminate any solder voids between the exposed heat slug and the land pattern.

Note: These recommendations are to be used as a guideline only. For further information, please refer to the Application Note on the Surface Mount Assembly of Amkor’s Thermally/ Electrically Enhance Leadframe Base Package, Amkor Technology.

**Figure 14. P.C. Assembly for Exposed Pad Thermal Release Path – Side View (Drawing not to Scale)**



### PCI Express Application Note

PCI Express jitter analysis methodology models the system response to reference clock jitter. The block diagram below shows the most frequently used *Common Clock Architecture* in which a copy of the reference clock is provided to both ends of the PCI Express Link.

In the jitter analysis, the transmit (Tx) and receive (Rx) SerDes PLLs are modeled as well as the phase interpolator in the receiver. These transfer functions are called H1, H2, and H3 respectively. The overall system transfer function at the receiver is:

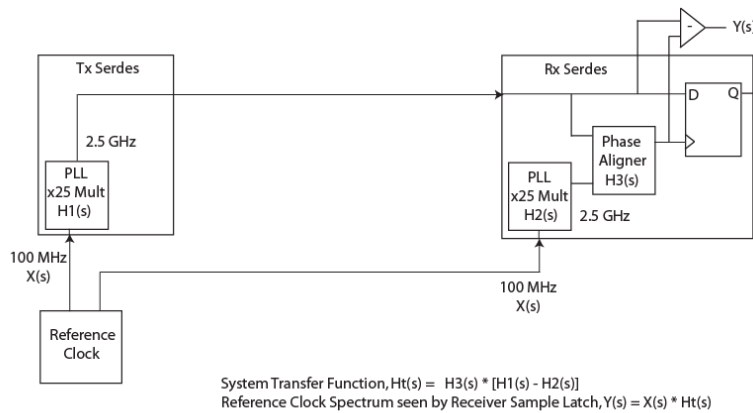
$$H_t(s) = H_3(s) \times [H_1(s) - H_2(s)]$$

The jitter spectrum seen by the receiver is the result of applying this system transfer function to the clock spectrum X(s) and is:

$$Y(s) = X(s) \times H_3(s) \times [H_1(s) - H_2(s)]$$

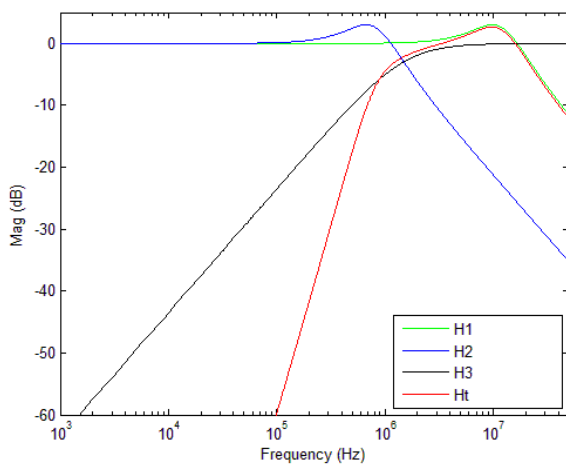
In order to generate time domain jitter numbers, an inverse Fourier Transform is performed on  $X(s) \times H_3(s) \times [H_1(s) - H_2(s)]$ .

**Figure 15. PCI Express Common Clock Architecture**



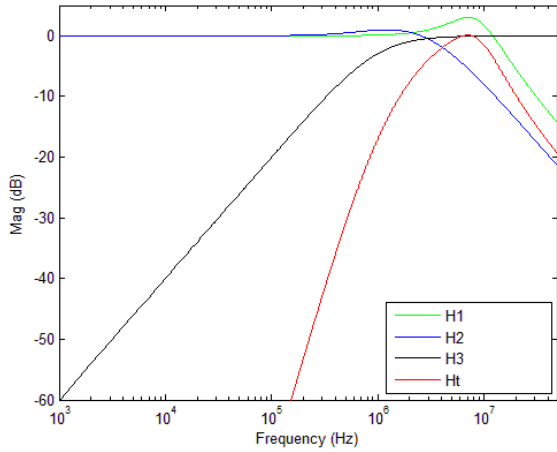
For **PCI Express Gen 1**, one transfer function is defined and the evaluation is performed over the entire spectrum: DC to Nyquist (e.g. for a 100MHz reference clock: 0Hz – 50MHz) and the jitter result is reported in peak-peak.

**Figure 16. PCIe Gen 1 Magnitude of Transfer Function**

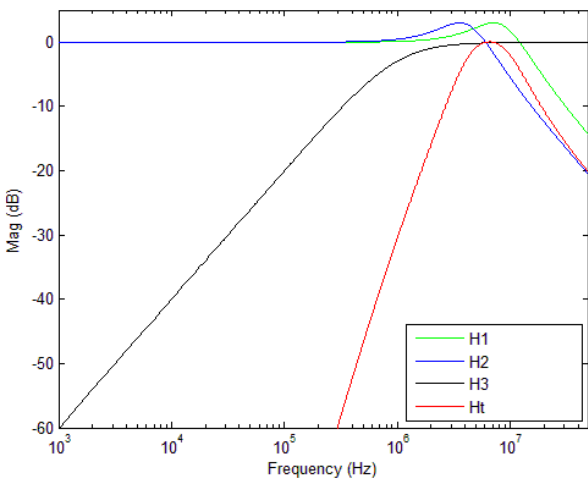


For **PCI Express Gen 2**, two transfer functions are defined with 2 evaluation ranges and the final jitter number is reported in RMS. The two evaluation ranges for PCI Express Gen 2 are 10kHz – 1.5MHz (low band) and 1.5MHz – Nyquist (high band). The plots show the individual transfer functions as well as the overall transfer function Ht.

**Figure 17. PCIe Gen 2A Magnitude of Transfer Function**

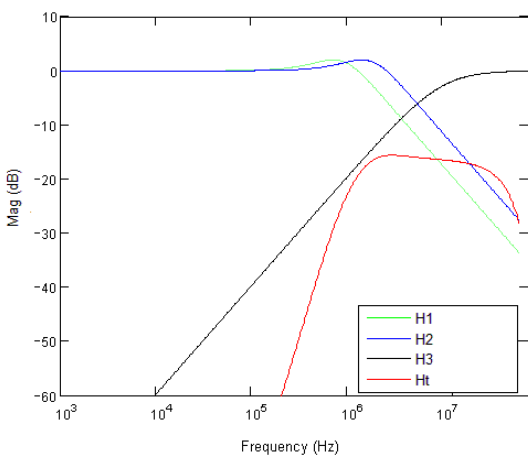


**Figure 18. PCIe Gen 2B Magnitude of Transfer Function**



For **PCI Express Gen 3**, one transfer function is defined and the evaluation is performed over the entire spectrum. The transfer function parameters are different from Gen 1 and the jitter result is reported in RMS.

**Figure 19. PCIe Gen 3 Magnitude of Transfer Function**



For a more thorough overview of PCI Express jitter analysis methodology, please refer to Renesas application note, *PCI Express Reference Clock Requirements*.

## Schematic and Layout Recommendations

Figure 20 and Figure 21 show an example 8V41NS0412 application schematic operating the device at  $V_{CC} = 3.3V$ . This example focuses on functional connections and is not configuration specific. Refer to Pin Description to ensure that the logic control inputs are properly set for the application.

Figure 20. 8V41NS0412 Application Schematic – Page 1

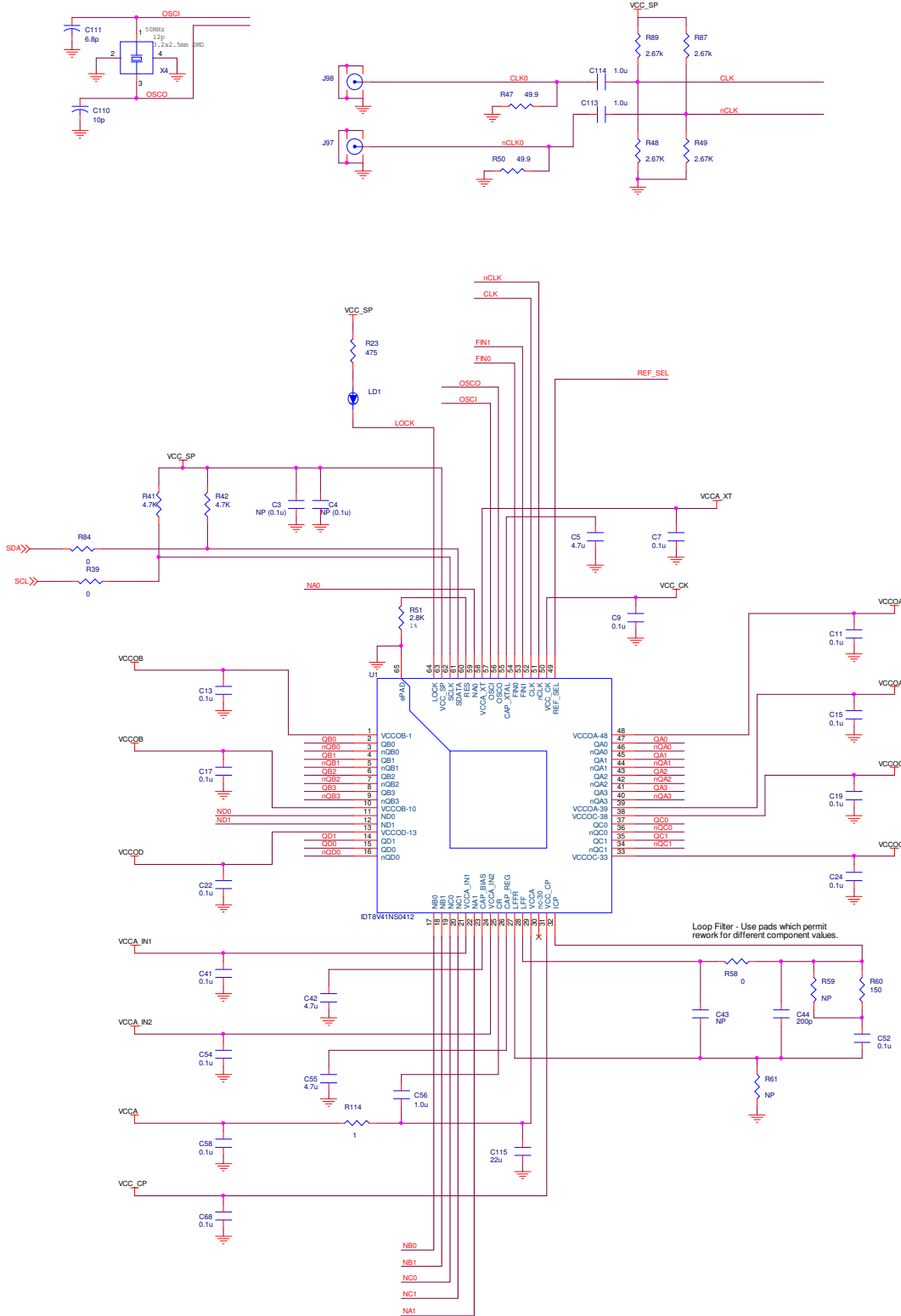
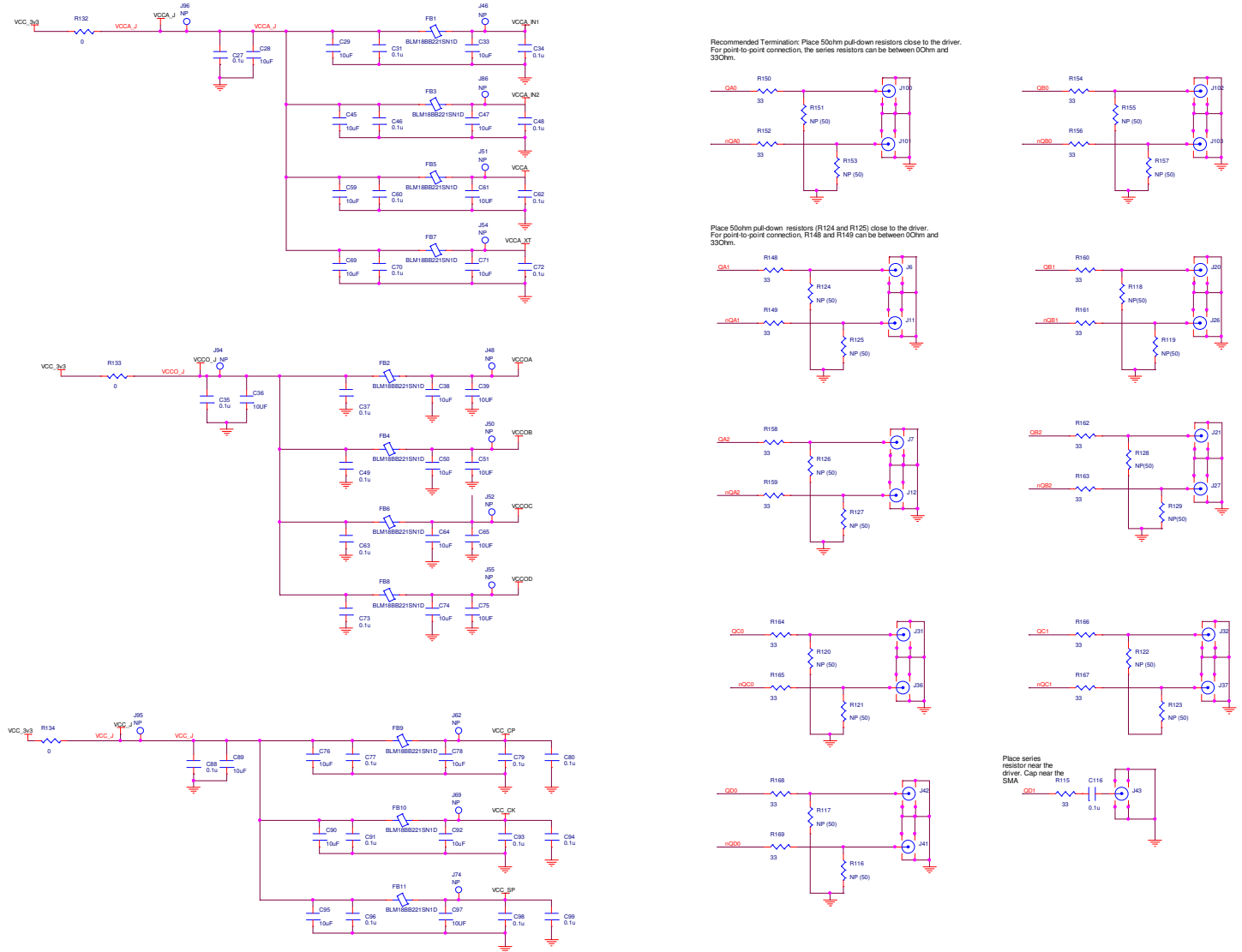


Figure 21. 8V41NS0412 Application Schematic – Page 2



To demonstrate the range of output stage configurations possible, the application schematic assumes that the 8V41NS0412 is programmed over I<sup>2</sup>C. For alternative DC coupled LVPECL options, please see Renesas Application Note, AN-828; for AC coupling options, use Renesas Application Note, AN-844.

For a 12pF parallel resonant crystal, tuning capacitors C145 and C146 are recommended for frequency accuracy. Depending on the parasitic of the PCB layout, these values may require a slight adjustment to optimize the frequency accuracy. Crystals with other load capacitance specifications can be used. This will require adjusting C145 and C146. For this device, the crystal tuning capacitors are required for proper operation.

Crystal layout is very important to minimize capacitive coupling between the crystal pads and leads and other metal in the circuit board. Capacitive coupling to other conductors has two adverse effects: it reduces the oscillator frequency leaving less tuning margin and noise coupling from power planes, and logic transitions on signal traces can pull the phase of the crystal resonance, inducing jitter. Routing I<sup>2</sup>C under the crystal is a common layout error, based on the assumption that it is a low frequency signal and will not affect the crystal oscillation. In fact, I<sup>2</sup>C transition times are short enough to capacitively couple into the crystal-oscillator loop if they are routed close enough to the crystal traces.

In layout, all capacitive coupling to the crystal from any signal trace is to be minimized, that is to the OSCI and OSCO pins, traces to the crystal pads, the crystal pads, and the tuning capacitors. Using a crystal on the top layer as an example, void all signal and power layers under the crystal connections between the top layer and the ground plane used by the 8V41NS0412. Then calculate the parasitic capacity to the ground and determine if it is large enough to preclude tuning the oscillator. If the coupling is excessive, particularly if the first layer under the crystal is a ground plane, a layout option is to void the ground plane and all deeper layers until the next ground plane is reached. The ground connection of the tuning capacitors should first be made between the capacitors on the top layer, then a single ground via is dropped to connect the tuning cap ground to the ground plane as close to the 8V41NS0412 as possible as shown in the schematic.

As with any high-speed analog circuitry, the power supply pins are vulnerable to random noise. To achieve optimum jitter performance, power supply isolation is required. The 8V41NS0412 provides separate power supplies to isolate any high switching noise from coupling into the internal PLL.

In order to achieve the best possible filtering, it is recommended that the placement of the filter components be on the device side of the PCB as close to the power pins as possible. The ferrite bead and the 0.1 $\mu$ F capacitor in each power pin filter should always be placed on the device side of the board. The other components can be on the opposite side of the PCB if space on the top side is limited. Pull-up and pull-down resistors to set configuration pins can all be placed on the PCB side opposite the device side to free up the device side area if necessary.

Power supply filter recommendations are a general guideline to be used for reducing external noise from coupling into the devices. Depending on the application, the filter may need to be adjusted to get a lower cutoff frequency to adequately attenuate low-frequency noise. Additionally, good general design practices for power plane voltage stability suggest adding bulk capacitance in the local area of all devices.

## Power Dissipation and Thermal Considerations

The 8V41NS0412 is a multi-functional, high speed device that targets a wide variety of clock frequencies and applications. Since this device is highly programmable with a broad range of features and functionality, the power consumption will vary as each of these features and functions is enabled.

The 8V41NS0412 device was designed and characterized to operate within the ambient industrial temperature range of -40°C to 85°C. The ambient temperature represents the temperature around the device, not the junction temperature. When using the device in extreme cases, such as maximum operating frequency and high ambient temperature, external air flow may be required in order to ensure a safe and reliable junction temperature. Extreme care must be taken to avoid exceeding 125°C junction temperature.

The power calculation examples below were generated using a maximum ambient temperature and supply voltage. For many applications, the power consumption will be lower. Please contact Renesas technical support for any concerns on calculating the power dissipation for your own specific configuration.

## Example of Junction Temperature Calculation

This section provides information on power dissipation and junction temperature. Equations and example calculations are also provided.

**Table 31. Power Calculations Configuration #1**

Output	Output Style
QA0	HCSL
QA1	HCSL
QA2	HCSL
QA3	HCSL
QB0	HCSL
QB1	HCSL
QB2	HCSL
QB3	HCSL
QC0	HCSL
QC1	HCSL
QD0	HCSL
QD1	LVC MOS

### 1. Power Dissipation.

The total power dissipation is the sum of the core power plus the power dissipated due to output loading.

The following is the power dissipation for  $V_{DD} = 3.465V$  and Temperature =  $85^{\circ}C$ .

- $Power(core)_{MAX} = V_{DD\_MAX} \times (I_{DD\_MAX} + I_{DDA\_MAX} + I_{DDO\_MAX}^{[1]}) = 3.465V \times (110 + 165 + 265)mA = 1871.1mW$
- $Power(HCSL\ outputs)_{MAX} = 40.7mW/loaded\ output\ pair.$ 
  - If all outputs are loaded, the total power is  $11 \times 40.7mW = 447.7mW$
- **Total Power<sub>MAX</sub> = Power(core) + Power (HCSL outputs) =**  
 $1871.1mW + 447.7mW = 2318.8mW$

### 2. Junction Temperature.

Junction temperature,  $T_J$ , is the temperature at the junction of the bond wire and bond pad and directly affects the reliability of the device. The maximum recommended junction temperature is  $125^{\circ}C$ . Limiting the internal transistor junction temperature,  $T_J$ , to  $125^{\circ}C$  ensures that the bond wire and bond pad temperature remains below  $125^{\circ}C$ .

The equation for  $T_J$  is as follows:  $T_J = T_A + P_D \times \theta_{JA}$ :

$T_J$  = Junction Temperature

$T_A$  = Ambient Temperature

$P_D$  = Power Dissipation (W) in desired operating configuration

$\theta_{JA}$  = Junction-to-Ambient Thermal Resistance

In order to calculate junction temperature, the appropriate junction-to-ambient thermal resistance must be used. Assuming no air flow and a multi-layer board, the appropriate value is  $15.6^{\circ}C/W$  per [Table 32](#).

[1]  $I_{DDO\_MAX}$  includes all output current including LVC MOS switching current.

Therefore, assuming  $T_A = 85^\circ\text{C}$  and all outputs switching,  $T_J$  will be:

$$85^\circ\text{C} + 2.3188\text{W} \times 15.6^\circ\text{C/W} = 121.2^\circ\text{C}.$$

This is below the limit of  $125^\circ\text{C}$ .

This calculation is only an example.  $T_J$  will obviously vary depending on the number of loaded outputs, supply voltage, air flow and the type of board (multi-layer).

**Table 32. Thermal Resistance Table for 64-pin VFQFN Package**

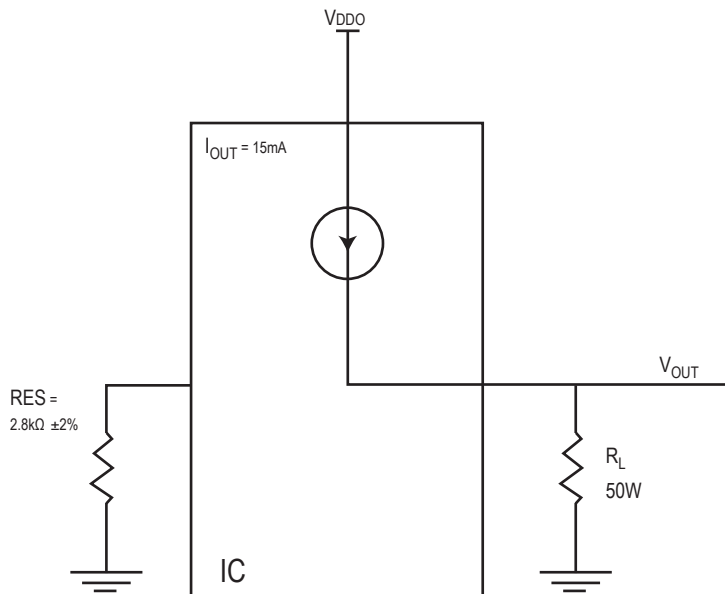
Symbol	Thermal Parameter	Condition	Value	Unit
$\theta_{JA}^{[a]}$	Junction-to-Ambient	No air flow	15.6	$^\circ\text{C/W}$
$\theta_{JC}$	Junction-to-Case		15.3	$^\circ\text{C/W}$
$\theta_{JB}$	Junction-to-Board		0.6	$^\circ\text{C/W}$

[a] Theta JA ( $\theta_{JA}$ ) values calculated using an 8-layer PCB ( $114.3 \times 101.6\text{mm}$ ), with 2oz. ( $70\mu\text{m}$ ) copper plating on all 8 layers, with ePad connected to 4 ground planes.

### 3. Calculations and Equations.

The purpose of this section is to calculate power dissipation on the IC per HCSL output pair. HCSL output driver circuit and termination are shown in Figure 22.

**Figure 22. HCSL Driver Circuit and Termination**



HCSL is a current steering output which sources a maximum of 15mA of current per output. To calculate worst case on-chip power dissipation, use the following equations which assume a  $50\Omega$  load to ground.

The highest power dissipation occurs when  $V_{DDO\_MAX}$ .

$$\text{Power} = (V_{DDO\_MAX} - V_{OUT}) \times I_{OUT}$$

since  $V_{OUT} = I_{OUT} \times R_L$

$$\begin{aligned} \text{Power} &= (V_{DDO\_MAX} - I_{OUT} \times R_L) \times I_{OUT} \\ &= (3.465\text{V} - 15\text{mA} \times 50\Omega) \times 15\text{mA} \end{aligned}$$

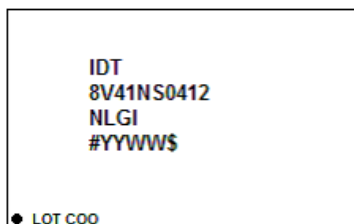
Total Power Dissipation per output pair = **40.7mW**

## Package Drawings

The package outline drawings are appended at the end of this document and are accessible from the link below. The package information is the most current data available.

[www.idt.com/document/psc/64-vfqfn-package-outline-drawing-90-x-90-x-09-mm-body-05mm-pitch-epad-60-x-60-mm-nlg64p5](http://www.idt.com/document/psc/64-vfqfn-package-outline-drawing-90-x-90-x-09-mm-body-05mm-pitch-epad-60-x-60-mm-nlg64p5)

## Marking Diagram



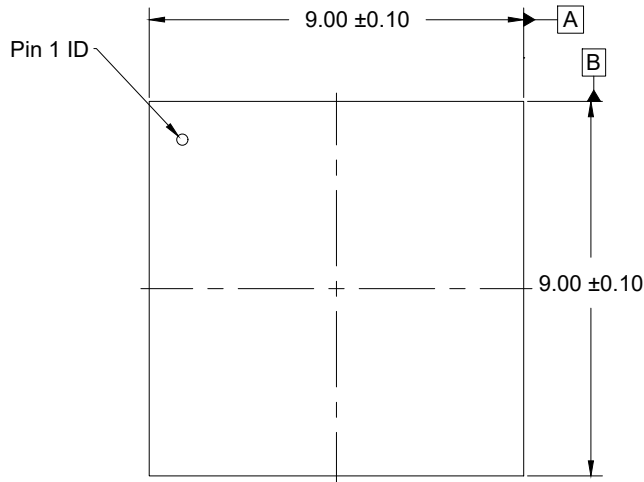
1. Line 1 indicates the part number prefix.
2. Line 2 indicates the part number.
3. Line 3 indicates the part number suffix.
4. "YYWW": date code
  - "#": stepping
  - "YY" is the last two digits of the year;
  - "WW" is a work week number that the part was assembled;
  - "\$" is the mark code.

## Ordering Information

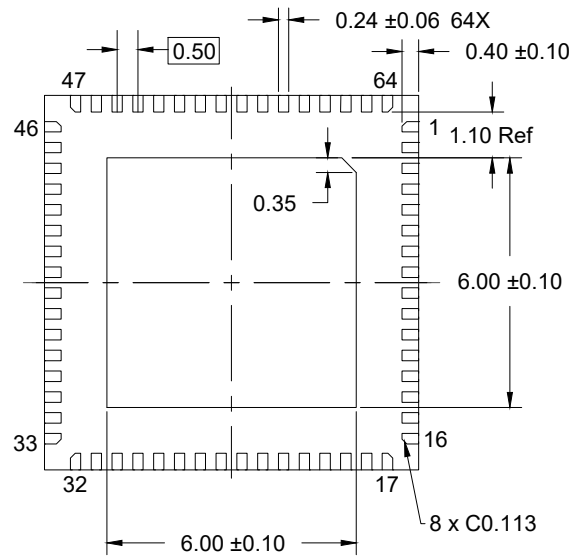
Part/Order Number	Marking	Package	Shipping Packaging	Temperature
8V41NS0412NLGI	IDT8V41NS0412NLGI	9 × 9 mm 64-VFQFN, Lead-Free	Tray	-40°C to +85°C
8V41NS0412NLGI8	IDT8V41NS0412NLGI	9 × 9 mm 64-VFQFN, Lead-Free	Tape and Reel	-40°C to +85°C

## Revision History

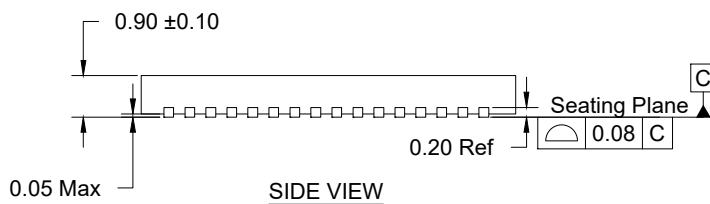
Revision Date	Description of Change
August 27, 2020	Removed all references to the function, "No active receivers should be connected to QA outputs" in <a href="#">Table 7</a> to <a href="#">Table 10</a> , and in <a href="#">Table 13</a> to <a href="#">Table 16</a>
April 25, 2018	Initial release.



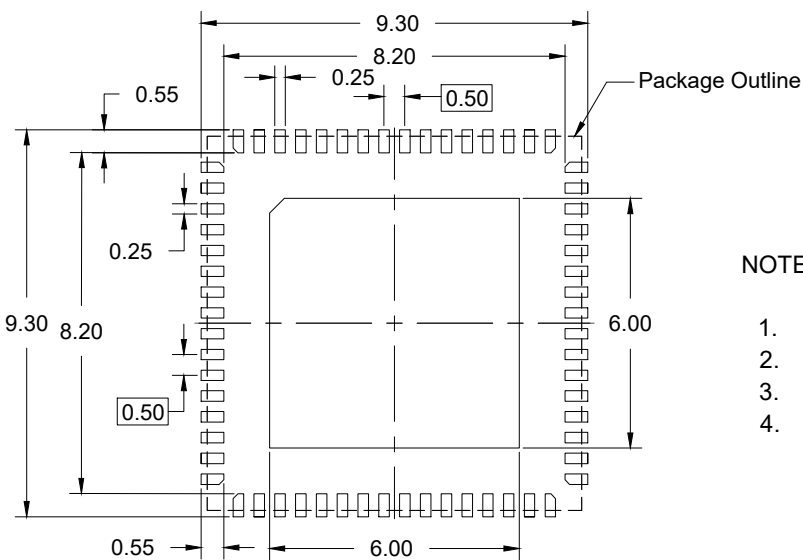
TOP VIEW



BOTTOM VIEW



SIDE VIEW



RECOMMENDED LAND PATTERN  
(PCB Top View, NSMD Design)

NOTES:

1. JEDEC compatible.
2. All dimensions are in mm and angles are in degrees.
3. Use  $\pm 0.05$  mm for the non-toleranced dimensions.
4. Numbers in ( ) are for references only.

## IMPORTANT NOTICE AND DISCLAIMER

RENESAS ELECTRONICS CORPORATION AND ITS SUBSIDIARIES (“RENESAS”) PROVIDES TECHNICAL SPECIFICATIONS AND RELIABILITY DATA (INCLUDING DATASHEETS), DESIGN RESOURCES (INCLUDING REFERENCE DESIGNS), APPLICATION OR OTHER DESIGN ADVICE, WEB TOOLS, SAFETY INFORMATION, AND OTHER RESOURCES “AS IS” AND WITH ALL FAULTS, AND DISCLAIMS ALL WARRANTIES, EXPRESS OR IMPLIED, INCLUDING, WITHOUT LIMITATION, ANY IMPLIED WARRANTIES OF MERCHANTABILITY, FITNESS FOR A PARTICULAR PURPOSE, OR NON-INFRINGEMENT OF THIRD-PARTY INTELLECTUAL PROPERTY RIGHTS.

These resources are intended for developers who are designing with Renesas products. You are solely responsible for (1) selecting the appropriate products for your application, (2) designing, validating, and testing your application, and (3) ensuring your application meets applicable standards, and any other safety, security, or other requirements. These resources are subject to change without notice. Renesas grants you permission to use these resources only to develop an application that uses Renesas products. Other reproduction or use of these resources is strictly prohibited. No license is granted to any other Renesas intellectual property or to any third-party intellectual property. Renesas disclaims responsibility for, and you will fully indemnify Renesas and its representatives against, any claims, damages, costs, losses, or liabilities arising from your use of these resources. Renesas' products are provided only subject to Renesas' Terms and Conditions of Sale or other applicable terms agreed to in writing. No use of any Renesas resources expands or otherwise alters any applicable warranties or warranty disclaimers for these products.

(Disclaimer Rev.1.01 Jan 2024)

### Corporate Headquarters

TOYOSU FORESIA, 3-2-24 Toyosu,  
Koto-ku, Tokyo 135-0061, Japan  
[www.renesas.com](http://www.renesas.com)

### Trademarks



Renesas and the Renesas logo are trademarks of Renesas Electronics Corporation. All trademarks and registered trademarks are the property of their respective owners.

### Contact Information

For further information on a product, technology, the most up-to-date version of a document, or your nearest sales office, please visit [www.renesas.com/contact-us/](http://www.renesas.com/contact-us/).

## Looking for pricing, stock, or lifecycle information?

Click below to explore more details on WIN SOURCE:

-  [View 8V41NS0412NLGI on WIN SOURCE](#)
-  [Renesas Electronics America](#) Information

## Optimize Your Supply Chain with WIN SOURCE Solutions

-  Global Sourcing Solution
-  Obsolete Management
-  Cost Control Management
-  Shortage Management
-  Alternative Solution
-  Excess Inventory Management