



**THE DATASHEET OF  
AD9575ARUZLVD**



### FEATURES

Fully integrated VCO/PLL core

0.39 ps rms jitter from 12 kHz to 20 MHz at 156.25 MHz

0.15 ps rms jitter from 1.875 MHz to 20 MHz at 156.25 MHz

0.40 ps rms jitter from 12 kHz to 20 MHz at 106.25 MHz

0.15 ps rms jitter from 637 kHz to 10 MHz at 106.25 MHz

Input crystal frequency of 19.44 MHz, 25 MHz, or  
25.78125 MHz

Pin selectable divide ratios for 33.33 MHz, 62.5 MHz,  
100 MHz, 106.25 MHz, 125 MHz, 155.52 MHz, 156.25 MHz,  
159.375 MHz, 161.13 MHz, and 312.5 MHz outputs

LVDS/LVPECL/LVCMOS output format

Integrated loop filter

Space saving 4.4 mm × 5.0 mm TSSOP

100 mA power supply current (LVDS output)

120 mA power supply current (LVPECL output)

3.3 V operation

### APPLICATIONS

GbE/FC/SONET line cards, switches, and routers

CPU/PCI-E applications

Low jitter, low phase noise clock generation

### GENERAL DESCRIPTION

The AD9575 provides a highly integrated, dual output clock generator function including an on-chip PLL core that is optimized for network clocking. The integer-N PLL design is based on the Analog Devices, Inc., proven portfolio of high performance, low jitter frequency synthesizers to maximize line card performance. Other applications with demanding phase noise and jitter requirements also benefit from this part.

The PLL section consists of a low noise phase frequency detector (PFD), a precision charge pump (CP), a low phase noise voltage controlled oscillator (VCO), and pin selectable feedback and output dividers.

By connecting an external crystal, popular network output frequencies can be locked to the input reference. The output divider and feedback divider ratios are pin programmable for the required output rates. No external loop filter components are required, thus conserving valuable design time and board space.

The AD9575 is available in a 16-lead, 4.4 mm × 5.0 mm TSSOP and can be operated from a single 3.3 V supply. The temperature range is -40°C to +85°C.

### FUNCTIONAL BLOCK DIAGRAM

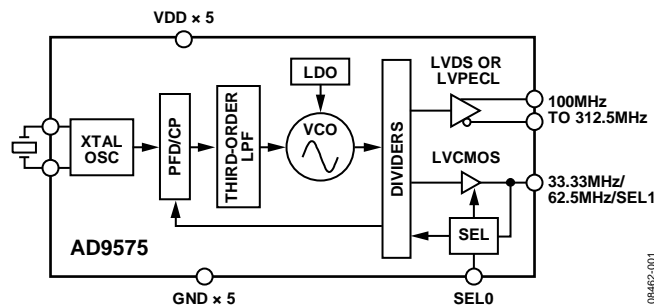

Figure 1.

### Rev. A

Information furnished by Analog Devices is believed to be accurate and reliable. However, no responsibility is assumed by Analog Devices for its use, nor for any infringements of patents or other rights of third parties that may result from its use. Specifications subject to change without notice. No license is granted by implication or otherwise under any patent or patent rights of Analog Devices. Trademarks and registered trademarks are the property of their respective owners.

## TABLE OF CONTENTS

Features .....	1	Absolute Maximum Ratings .....	7
Applications.....	1	Thermal Resistance .....	7
General Description .....	1	ESD Caution.....	7
Functional Block Diagram .....	1	Pin Configuration and Function Descriptions.....	8
Revision History .....	2	Typical Performance Characteristics .....	9
Specifications.....	3	Terminology .....	11
PLL Characteristics .....	3	Theory of Operation .....	12
LVDS Clock Output Jitter (Typ/Max).....	4	Phase Frequency Detector (PFD) and Charge Pump.....	12
LVPECL Clock Output Jitter (Typ/Max).....	4	Power Supply.....	12
Output Frequency Select .....	5	LVPECL Clock Distribution .....	12
Clock Outputs .....	5	LVDS Clock Distribution .....	13
Timing Characteristics .....	5	LVCMOS Clock Distribution .....	13
Power.....	6	Typical Application Circuit.....	13
Crystal Oscillator.....	6	Outline Dimensions.....	14
Timing Diagrams.....	6	Ordering Guide .....	14

## REVISION HISTORY

### 3/10—Rev. 0 to Rev. A

Changes to Features Section.....	1
Changes to Table 1, Table 2, and Table 3 .....	4
Changes to Table 4 and Table 6.....	5
Changes to Table 7 and Table 8.....	6
Changes to Table 12.....	8
Added Figure 11; Renumbered Figures Sequentially .....	10
Changes to Figure 13.....	10
Changes to Theory of Operation Section and Figure 19.....	12
Changes to Figure 24.....	13

### 1/10—Revision 0: Initial Version

## SPECIFICATIONS

Typical (typ) values are given for  $V_S = 3.3 \text{ V} \pm 10\%$ ,  $T_A = 25^\circ\text{C}$ , unless otherwise noted. Minimum (min) and maximum (max) values are given over the full  $V_S$  and  $T_A$  ( $-40^\circ\text{C}$  to  $+85^\circ\text{C}$ ) variation.

### PLL CHARACTERISTICS

Table 1.

Parameter	LVDS			LVCMOS			LVPECL			Unit
	Min	Typ	Max	Min	Typ	Max	Min	Typ	Max	
PHASE NOISE CHARACTERISTICS										
PLL Noise (100 MHz Output)										
At 1 kHz		-123						-122		dBc/Hz
At 10 kHz		-128						-129		dBc/Hz
At 100 kHz		-131						-131		dBc/Hz
At 1 MHz		-150						-151		dBc/Hz
At 10 MHz		-156						-158		dBc/Hz
At 30 MHz		-156						-158		dBc/Hz
PLL Noise (106.25 MHz Output)										
At 1 kHz		-121						-121		dBc/Hz
At 10 kHz		-127						-128		dBc/Hz
At 100 kHz		-130						-130		dBc/Hz
At 1 MHz		-149						-150		dBc/Hz
At 10 MHz		-156						-158		dBc/Hz
At 30 MHz		-156						-159		dBc/Hz
PLL Noise (125 MHz Output)										
At 1 kHz		-120						-120		dBc/Hz
At 10 kHz		-126						-127		dBc/Hz
At 100 kHz		-128						-129		dBc/Hz
At 1 MHz		-148						-150		dBc/Hz
At 10 MHz		-155						-157		dBc/Hz
At 30 MHz		-156						-158		dBc/Hz
PLL Noise (155.52 MHz Output)										
At 1 kHz		-118						-118		dBc/Hz
At 10 kHz		-123						-123		dBc/Hz
At 100 kHz		-125						-125		dBc/Hz
At 1 MHz		-147						-149		dBc/Hz
At 10 MHz		-155						-157		dBc/Hz
At 30 MHz		-156						-157		dBc/Hz
PLL Noise (156.25 MHz Output)										
At 1 kHz		-118						-118		dBc/Hz
At 10 kHz		-124						-125		dBc/Hz
At 100 kHz		-126						-127		dBc/Hz
At 1 MHz		-146						-148		dBc/Hz
At 10 MHz		-155						-157		dBc/Hz
At 30 MHz		-155						-157		dBc/Hz
PLL Noise (159.375 MHz Output)										
At 1 kHz		-118						-118		dBc/Hz
At 10 kHz		-124						-125		dBc/Hz
At 100 kHz		-126						-126		dBc/Hz
At 1 MHz		-146						-147		dBc/Hz
At 10 MHz		-155						-156		dBc/Hz
At 30 MHz		-155						-157		dBc/Hz

# AD9575

Parameter	LVDS			LVCMOS			LVPECL			Unit
	Min	Typ	Max	Min	Typ	Max	Min	Typ	Max	
PLL Noise (161.132812 MHz Output)										
At 1 kHz		-118						-119		dBc/Hz
At 10 kHz		-122						-123		dBc/Hz
At 100 kHz		-126						-126		dBc/Hz
At 1 MHz		-144						-146		dBc/Hz
At 10 MHz		-154						-156		dBc/Hz
At 30 MHz		-155						-156		dBc/Hz
PLL Noise (312.5 MHz Output)										
At 1 kHz		-112						-112		dBc/Hz
At 10 kHz		-119						-119		dBc/Hz
At 100 kHz		-120						-120		dBc/Hz
At 1 MHz		-140						-142		dBc/Hz
At 10 MHz		-152						-154		dBc/Hz
At 30 MHz		-153						-155		dBc/Hz
PLL Noise (33.33 MHz Output)										
At 1 kHz					-131					dBc/Hz
At 10 kHz					-138					dBc/Hz
At 100 kHz					-140					dBc/Hz
At 1 MHz					-155					dBc/Hz
At 5 MHz					-155					dBc/Hz
PLL Noise (62.5 MHz Output)										
At 1 kHz					-126					dBc/Hz
At 10 kHz					-133					dBc/Hz
At 100 kHz					-134					dBc/Hz
At 1 MHz					-150					dBc/Hz
At 5 MHz					-152					dBc/Hz
Spurious Content		-70						-70		dBc
PLL Figure of Merit		-217						-217		dBc/Hz

## LVDS CLOCK OUTPUT JITTER (TYP/MAX)

Typical (typ) values are given for  $V_s = 3.3 \text{ V} \pm 10\%$ ,  $T_A = 25^\circ\text{C}$ , unless otherwise noted. Maximum (max) values are given over the full  $V_s$  and  $T_A$  ( $-40^\circ\text{C}$  to  $+85^\circ\text{C}$ ) variation.

Table 2.

Jitter Integration Bandwidth	100 MHz	106.25 MHz	125 MHz	155.52 MHz	156.25 MHz	159.375 MHz	161.13 MHz	312.5 MHz	Unit
12 kHz to 20 MHz	0.38/0.50	0.40/0.54	0.37/0.47	0.41/0.54	0.39/0.51	0.38/0.51	0.44/0.61	0.36/0.48	ps rms
1.875 MHz to 20 MHz					0.15/0.27				ps rms
637 kHz to 10 MHz		0.15/0.21							ps rms

## LVPECL CLOCK OUTPUT JITTER (TYP/MAX)

Typical (typ) values are given for  $V_s = 3.3 \text{ V} \pm 10\%$ ,  $T_A = 25^\circ\text{C}$ , unless otherwise noted. Maximum (max) values are given over the full  $V_s$  and  $T_A$  ( $-40^\circ\text{C}$  to  $+85^\circ\text{C}$ ) variation.

Table 3.

Jitter Integration Bandwidth	100 MHz	106.25 MHz	125 MHz	155.52 MHz	156.25 MHz	159.375 MHz	161.13 MHz	312.5 MHz	Unit
12 kHz to 20 MHz	0.36/0.46	0.44/0.68	0.36/0.45	0.40/0.52	0.39/0.64	0.41/0.62	0.43/0.69	0.38/0.49	ps rms
1.875 MHz to 20 MHz					0.19/0.54				ps rms
637 kHz to 10 MHz		0.22/0.35							ps rms

## OUTPUT FREQUENCY SELECT

Minimum (min) and maximum (max) values are given over the full  $V_S$  and  $T_A$  ( $-40^{\circ}\text{C}$  to  $+85^{\circ}\text{C}$ ) variation.

Table 4.

Parameter	Min	Typ	Max	Unit	Test Conditions/Comments
Select Pins (SELO/SEL1)					
Logic 1 Voltage	$0.83 \times V_S + 0.2$			V	
Logic 0 Voltage			$0.33 \times V_S - 0.2$	V	
Logic 1 Current			190	$\mu\text{A}$	Pull-up to $V_S$
Logic 0 Current			150	$\mu\text{A}$	Pull-down to GND

## CLOCK OUTPUTS

Typical (typ) values are given for  $V_S = 3.3 \text{ V} \pm 10\%$ ,  $T_A = 25^{\circ}\text{C}$ , unless otherwise noted. Minimum (min) and maximum (max) values are given over the full  $V_S$  and  $T_A$  ( $-40^{\circ}\text{C}$  to  $+85^{\circ}\text{C}$ ) variation.

Table 5.

Parameter	Min	Typ	Max	Unit	Test Conditions/Comments
LVDS CLOCK OUTPUT					Termination = $100 \Omega$ differential; default
Output Frequency			312.5	MHz	
Differential Output Voltage ( $V_{OD}$ )	250	340	450	mV	See Figure 2 for definition
Delta $V_{OD}$			25	mV	
Output Offset Voltage ( $V_{OS}$ )	1.125	1.25	1.375	V	
Delta $V_{OS}$			25	mV	
Short-Circuit Current ( $I_{SA}$ , $I_{SB}$ )		14	24	mA	Output shorted to GND
Duty Cycle	45	50	55	%	
LVPECL CLOCK OUTPUT					
Output Frequency			312.5	MHz	
Output High Voltage ( $V_{OH}$ )	$V_S - 1.5$	$V_S - 1.05$	$V_S - 0.8$	V	
Output Low Voltage ( $V_{OL}$ )	$V_S - 2.5$	$V_S - 1.75$	$V_S - 1.7$	V	
Differential Output Voltage ( $V_{OD}$ )	430	640	800	mV	See Figure 2 for definition
Duty Cycle	45	50	55	%	
LVC MOS CLOCK OUTPUT					
Output Frequency			62.5	MHz	
Output High Voltage ( $V_{OH}$ )	$V_S - 0.1$			V	
Output Low Voltage ( $V_{OL}$ )			0.1	V	
Duty Cycle	45	50	55	%	

## TIMING CHARACTERISTICS

Table 6.

Parameter	Min	Typ	Max	Unit	Test Conditions/Comments
LVDS					Termination = $100 \Omega$ differential; $C_{LOAD} = 0 \text{ pF}$ ; $C_{AC} = 0.1 \mu\text{F}$
Output Rise Time, $t_{RL}$	150	200	300	ps	20% to 80%, measured differentially
Output Fall Time, $t_{FL}$	150	200	300	ps	80% to 20%, measured differentially
LVPECL					Termination = $200 \Omega$ to GND; $C_{LOAD} = 0 \text{ pF}$ ; $C_{AC} = 0.1 \mu\text{F}$
Output Rise Time, $t_{RL}$	180	250	300	ps	20% to 80%, measured differentially
Output Fall Time, $t_{FL}$	180	250	300	ps	80% to 20%, measured differentially
LVC MOS					Termination = $50 \Omega$ to 0 V; $C_{LOAD} = 5 \text{ pF}$ ; $C_{AC} = 0.1 \mu\text{F}$
Output Rise Time, $t_{RC}$	0.50	0.70	1.10	ns	20% to 80%
Output Fall Time, $t_{FC}$	0.50	0.70	1.10	ns	80% to 20%

# AD9575

## POWER

Table 7.

Parameter	Min	Typ	Max	Unit
POWER SUPPLY	3.0	3.3	3.6	V
POWER SUPPLY CURRENT				
LVDS		100	130	mA
LVPECL		120	160	mA

## CRYSTAL OSCILLATOR

Table 8.

Parameter	Min	Typ	Max	Unit	Test Conditions/Comments
CRYSTAL SPECIFICATION					Parallel resonant/fundamental mode
Frequency	19.44	25	25.78125	MHz	
ESR			40	$\Omega$	
Load Capacitance		14		pF	Cx/2 (see Figure 24) + parasitic capacitance
Phase Noise		-138		dBc/Hz	At 1 kHz offset
Stability	-30		+30	ppm	

## TIMING DIAGRAMS

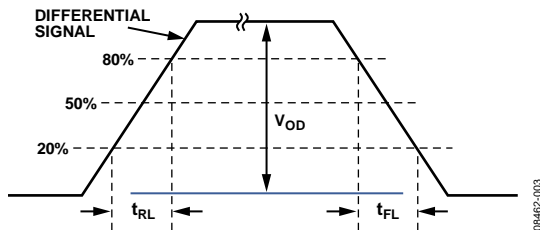

Figure 2. LVDS or LVPECL Timing and Differential Amplitude

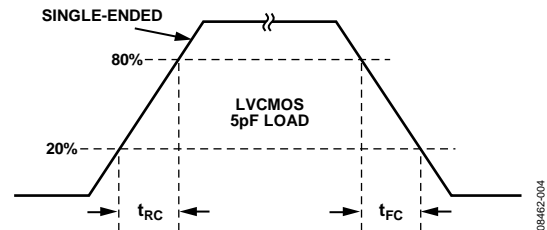

Figure 3. LVCMOS Timing

## ABSOLUTE MAXIMUM RATINGS

Table 9.

Parameter	Rating
VDD, VDDA, VDDX, VDD_CMOS to GND	−0.3 V to +3.6 V
XO1, XO2 to GND	−0.3 V to $V_S + 0.3$ V
LVDS/LVPECL OUT, $\overline{\text{LVDS/LVPECL OUT}}$ , CMOS OUT/SEL1, SEL0 to GND	−0.3 V to $V_S + 0.3$ V
Junction Temperature <sup>1</sup>	150°C
Storage Temperature Range	−65°C to +150°C
Lead Temperature (10 sec)	300°C

<sup>1</sup> See Table 10 for  $\theta_{JA}$ .

Stresses above those listed under Absolute Maximum Ratings may cause permanent damage to the device. This is a stress rating only; functional operation of the device at these or any other conditions above those indicated in the operational section of this specification is not implied. Exposure to absolute maximum rating conditions for extended periods may affect device reliability.

## THERMAL RESISTANCE

$\theta_{JA}$  is specified for the worst-case conditions, that is, a device soldered in a circuit board for surface-mount packages.

Table 10. Thermal Resistance<sup>1</sup>

Package Type	$\theta_{JA}$	Unit
16-Lead TSSOP (RU-16)	90.3	°C/W

<sup>1</sup> Thermal impedance measurements were taken on a 4-layer board in still air in accordance with EIA/JESD51-7.

## ESD CAUTION



**ESD (electrostatic discharge) sensitive device.** Charged devices and circuit boards can discharge without detection. Although this product features patented or proprietary protection circuitry, damage may occur on devices subjected to high energy ESD. Therefore, proper ESD precautions should be taken to avoid performance degradation or loss of functionality.

# AD9575

## PIN CONFIGURATION AND FUNCTION DESCRIPTIONS

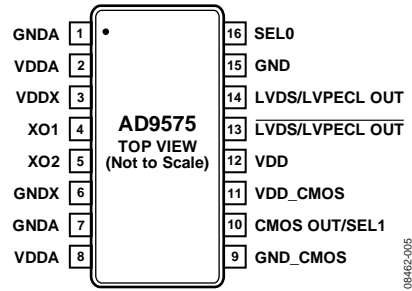

Figure 4. Pin Configuration

Table 11. Pin Function Descriptions

Pin No.	Mnemonic	Description
1, 7	GNDA	Analog Ground.
2, 8	VDDA	Analog Power Supply (3.3 V).
3	VDDX	Crystal Oscillator Power Supply.
4, 5	XO1, XO2	External Crystal.
6	GNDX	Crystal Oscillator Ground.
9	GND_CMOS	Ground for LVCMOS Output.
10	CMOS OUT/SEL1	LVCMOS Output/Output Frequency Select.
11	VDD_CMOS	Power Supply for LVCMOS Output.
12	VDD	Power Supply for LVDS or LVPECL Output.
13	LVDS/LVPECL OUT	Complementary LVDS or LVPECL Output.
14	LVDS/LVPECL OUT	LVDS or LVPECL Output.
15	GND	Ground for LVDS or LVPECL Output.
16	SEL0	Output Frequency Select.

Table 12. Output Frequency Selection<sup>1</sup>

Mode	XTAL	SEL0	SEL1	LVDS/LVPECL Output	LVCMOS Output
1	25 MHz	GND	X <sup>2</sup>	100 MHz	33.33 MHz
2	25 MHz	V <sub>s</sub>	GND	156.25 MHz	High-Z
3	25.78125 MHz	V <sub>s</sub>	GND	161.13 MHz	High-Z
4	25 MHz	No connect	X <sup>2</sup>	125 MHz	62.5 MHz
5	25 MHz	15 kΩ pull-up	V <sub>s</sub>	159.375 MHz	High-Z
6	25 MHz	15 kΩ pull-up	GND	312.5 MHz	High-Z
7	25 MHz	V <sub>s</sub>	V <sub>s</sub>	106.25 MHz	High-Z
8	19.44 MHz	V <sub>s</sub>	No connect	155.52 MHz	High-Z

<sup>1</sup> The AD9575 must be power-cycled if the select pin voltages are altered.

<sup>2</sup> X = in Mode 1, Pin 10 is configured as an LVCMOS output (33.33 MHz) by forcing Pin 16 to GND. In Mode 4, Pin 10 is configured as an LVCMOS output (62.5 MHz) by leaving Pin 16 unconnected.

# TYPICAL PERFORMANCE CHARACTERISTICS

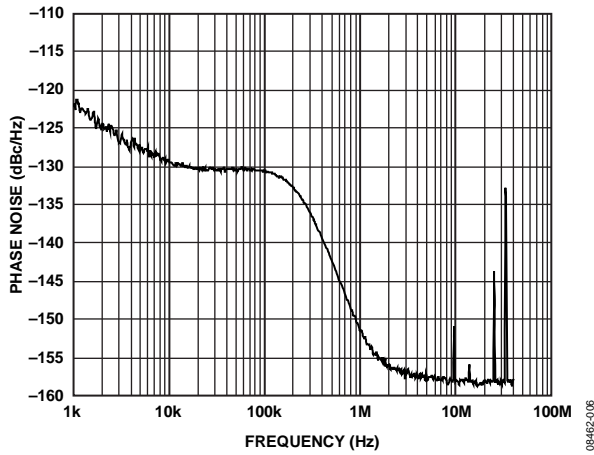

Figure 5. Phase Noise at LVPECL, 100 MHz Clock Output

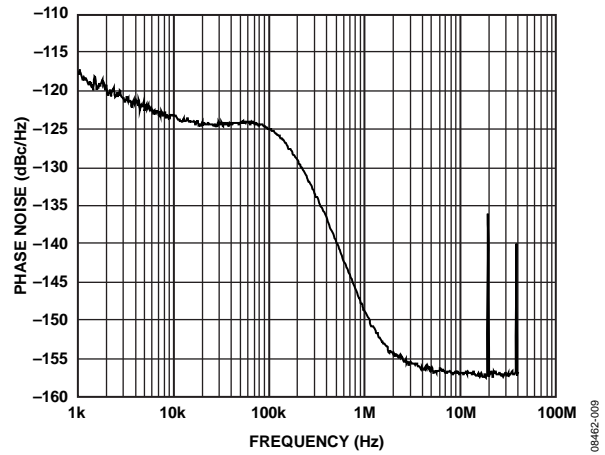

Figure 8. Phase Noise at LVPECL, 155.52 MHz Clock Output

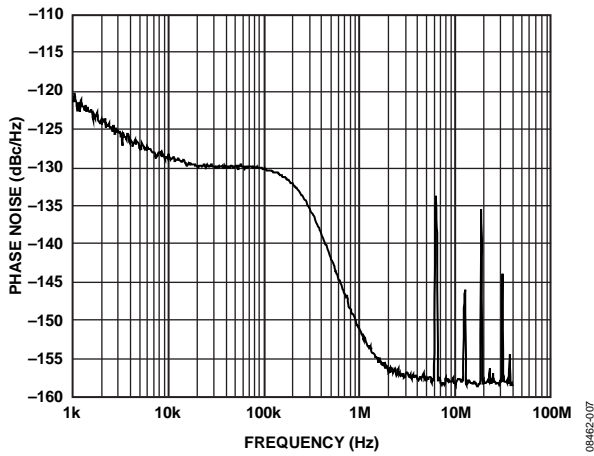

Figure 6. Phase Noise at LVPECL, 106.25 MHz Clock Output

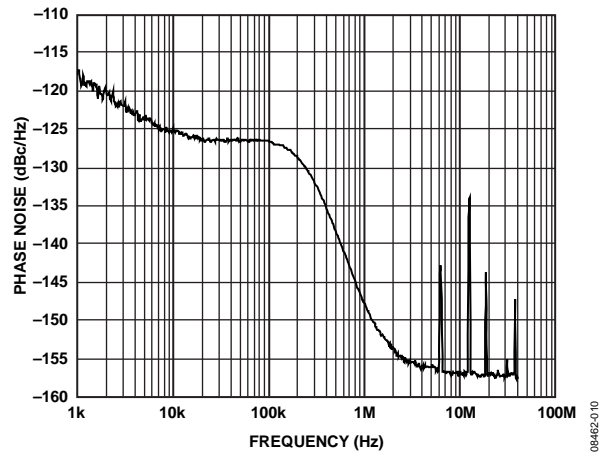

Figure 9. Phase Noise at LVPECL, 156.25 MHz Clock Output

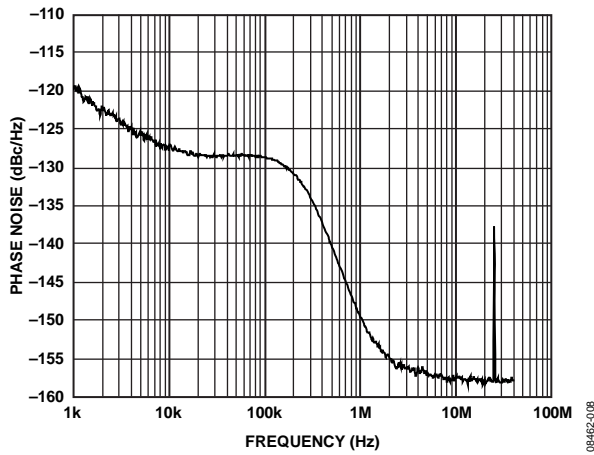

Figure 7. Phase Noise at LVPECL, 125 MHz Clock Output

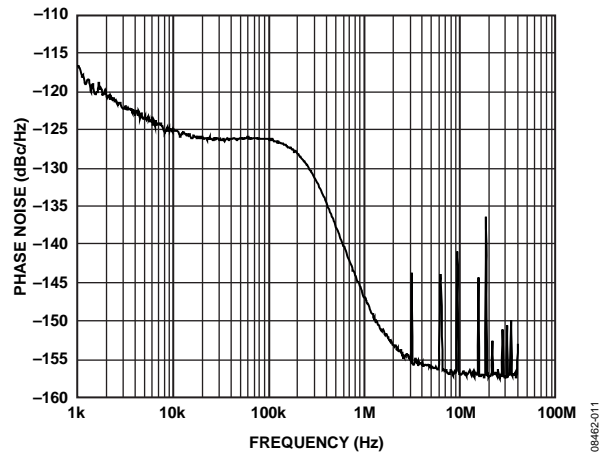

Figure 10. Phase Noise at LVPECL, 159.375 MHz Clock Output

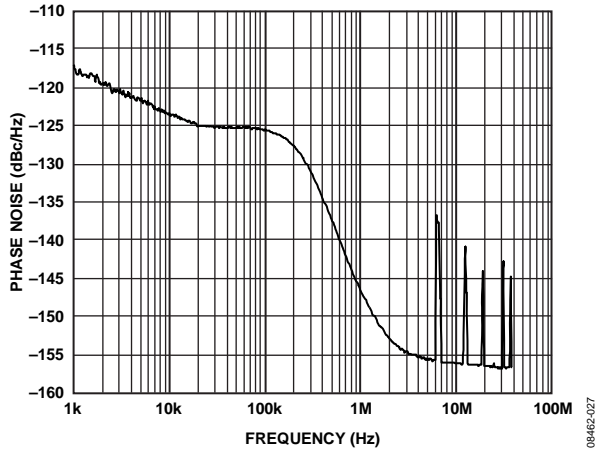

Figure 11. Phase Noise at LVPECL, 161.13 MHz Clock Output

08462-027

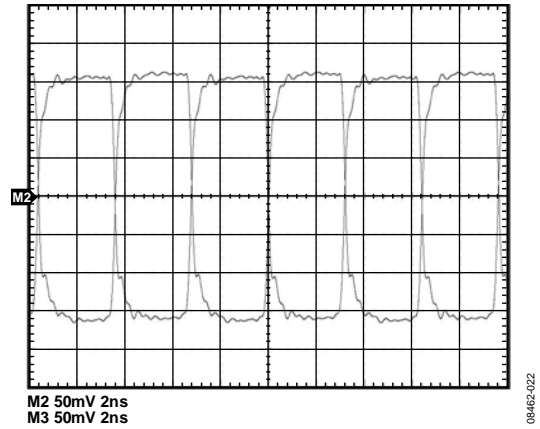

Figure 14. 156.25 MHz LVDS Output

08462-022

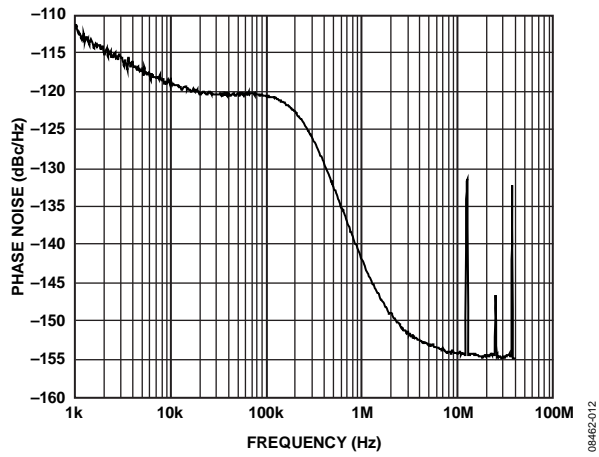

Figure 12. Phase Noise at LVPECL, 312.5 MHz Clock Output

08462-012

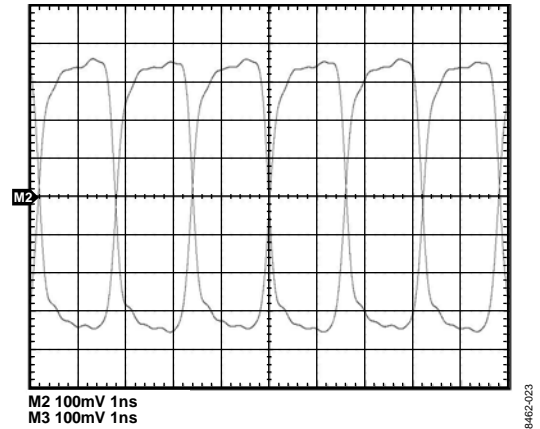

Figure 15. 312.5 MHz LVPECL Output

08462-023

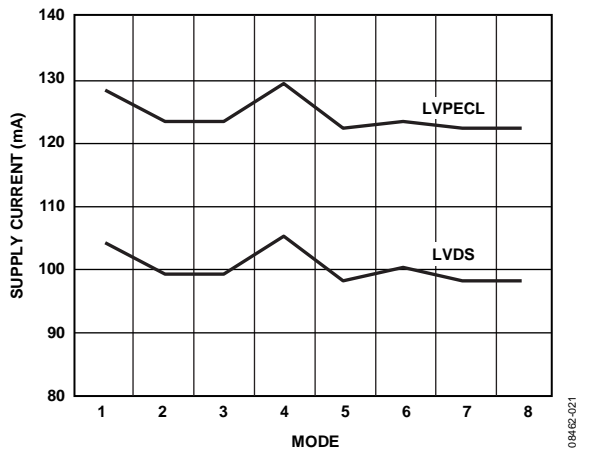

Figure 13. Typical Supply Current vs. Mode (see Table 12)

08462-021

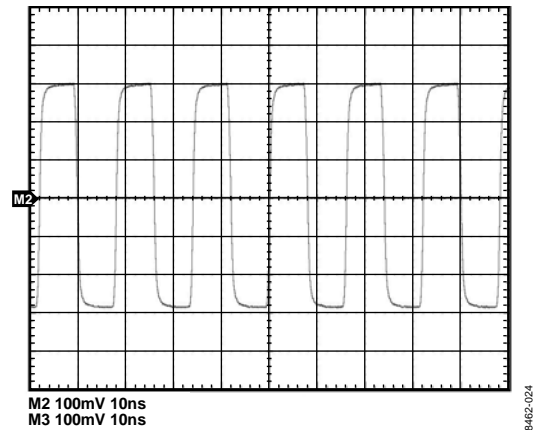

Figure 16. 62.5 MHz LVCMOS Output

08462-024

## TERMINOLOGY

### Phase Jitter

An ideal sine wave can be thought of as having a continuous and even progression of phase with time from  $0^\circ$  to  $360^\circ$  for each cycle. Actual signals, however, display a certain amount of variation from ideal phase progression over time. This phenomenon is called phase jitter. Although many causes can contribute to phase jitter, one major cause is random noise, which is characterized statistically as Gaussian (normal) in distribution.

This phase jitter leads to a spreading out of the energy of the sine wave in the frequency domain, producing a continuous power spectrum. This power spectrum is usually reported as a series of values whose units are dBc/Hz at a given offset in frequency from the sine wave (carrier). The value is a ratio (expressed in decibels) of the power contained within a 1 Hz bandwidth with respect to the power at the carrier frequency. For each measurement, the offset from the carrier frequency is also given.

### Phase Noise

It is meaningful to integrate the total power contained within some interval of offset frequencies (for example, 10 kHz to 10 MHz). This is called the integrated phase noise over that frequency offset interval and can be readily related to the time jitter due to the phase noise within that offset frequency interval.

Phase noise has a detrimental effect on error rate performance by increasing eye closure at the transmitter output and reducing the jitter tolerance/sensitivity of the receiver.

### Time Jitter

Phase noise is a frequency domain phenomenon. In the time domain, the same effect is exhibited as time jitter. When observing a sine wave, the time of successive zero crossings is seen to vary. In a square wave, the time jitter is seen as a displacement of the edges from their ideal (regular) times of occurrence. In both cases, the variations in timing from the ideal are the time jitter. Because these variations are random in nature, the time jitter is specified in units of seconds root mean square (rms) or 1 sigma of the Gaussian distribution.

### Additive Phase Noise

Additive phase noise is the amount of phase noise that is attributable to the device or subsystem being measured. The phase noise of any external oscillators or clock sources is subtracted. This makes it possible to predict the degree to which the device affects the total system phase noise when used in conjunction with the various oscillators and clock sources, each of which contributes its own phase noise to the total. In many cases, the phase noise of one element dominates the system phase noise.

### Additive Time Jitter

Additive time jitter is the amount of time jitter that is attributable to the device or subsystem being measured. The time jitter of any external oscillators or clock sources is subtracted. This makes it possible to predict the degree to which the device affects the total system time jitter when used in conjunction with the various oscillators and clock sources, each of which contributes its own time jitter to the total. In many cases, the time jitter of the external oscillators and clock sources dominates the system time jitter.

## THEORY OF OPERATION

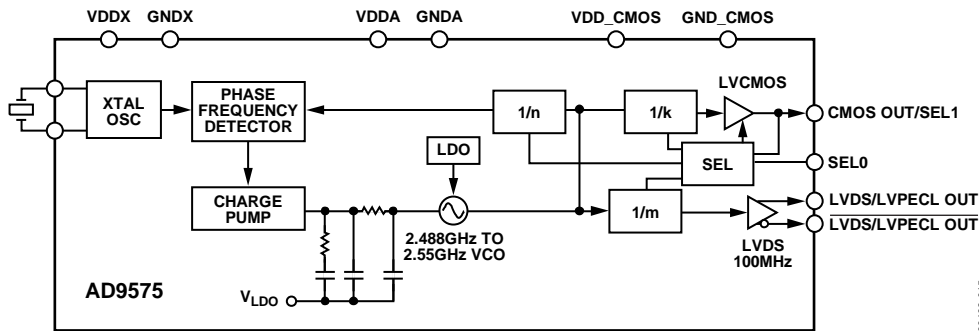

Figure 17. Detailed Block Diagram

Figure 17 shows a block diagram of the AD9575. The chip features a PLL core, which is configured to generate the specific clock frequencies via pin programming. By appropriate connection of the select pins, SEL0 and SEL1, the divide ratios of the feedback divider (n), LVDS output divider (m), and LVCMS output divider (k) can be programmed (see Table 12). In Mode 1 and Mode 4, Pin 10 is configured as an LVCMS output by forcing Pin 16 to GND (33.33 MHz output) or by leaving Pin 16 unconnected (62.5 MHz output). In conjunction with a band-select VCO that operates over the range of 2.488 GHz to 2.55 GHz, a wide range of popular network reference frequencies can be generated. This PLL is based on proven Analog Devices synthesizer technology, noted for its exceptional phase noise performance. The AD9575 is highly integrated and includes the loop filter, a regulator for supply noise immunity, all the necessary dividers, output buffers, and a crystal oscillator. A user need only supply an external crystal to implement a clocking solution that requires no processor intervention.

### PHASE FREQUENCY DETECTOR (PFD) AND CHARGE PUMP

The PFD takes inputs from the reference clock and feedback divider to produce an output proportional to the phase and frequency difference between them. Figure 18 shows a simplified schematic.

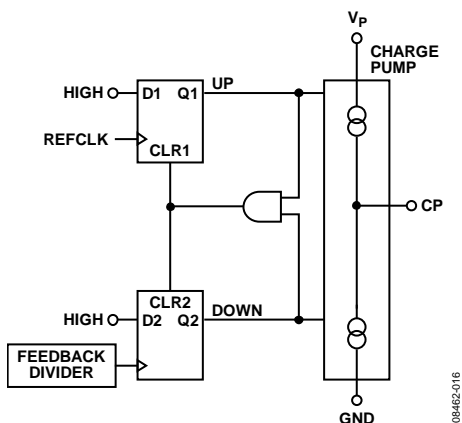

Figure 18. PFD Simplified Schematic

### POWER SUPPLY

The AD9575 requires a  $3.3 \text{ V} \pm 10\%$  power supply for  $V_S$ . The Specifications section gives the performance expected from the AD9575 with the power supply voltage within this range. The absolute maximum range of  $-0.3 \text{ V}$  to  $+3.6 \text{ V}$ , with respect to GND, must never be exceeded on the VDD, VDDA, VDDX, and VDD\_CMOS pins.

Good engineering practice should be followed in the layout of power supply traces and the ground plane of the PCB. The power supply should be bypassed on the PCB with adequate capacitance ( $>10 \mu\text{F}$ ). The AD9575 should be bypassed with adequate capacitors ( $0.1 \mu\text{F}$ ) at all power pins as close as possible to the part. The layout of the AD9575 evaluation board is a good example.

### LVPECL CLOCK DISTRIBUTION

Because they are open emitter, the LVPECL outputs require a dc termination to bias the output transistors. The simplified equivalent circuit in Figure 19 shows the LVPECL output stage.

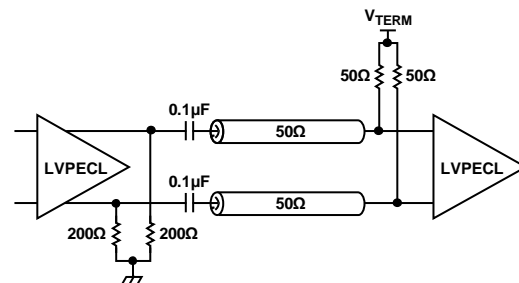

Figure 19. LVPECL AC-Coupled Termination

In most applications, a standard LVPECL far-end termination is recommended, as shown in Figure 20. The resistor network is designed to match the transmission line impedance ( $50 \Omega$ ) and the desired switching threshold ( $1.3 \text{ V}$ ).

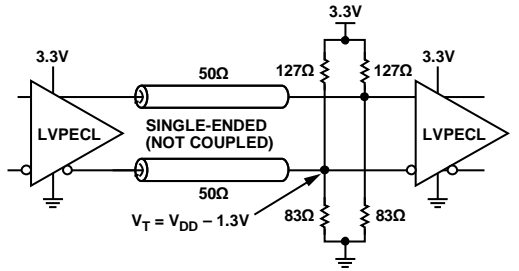

Figure 20. LVPECL Far-End Termination

**LVDS CLOCK DISTRIBUTION**

The AD9575 is also available with low voltage differential signaling (LVDS) outputs. LVDS uses a current mode output stage with a factory programmed current level. The normal value (default) for this current is 3.5 mA, which yields a 350 mV output swing across a 100 Ω resistor. The LVDS outputs meet or exceed all ANSI/TIA/EIA-644 specifications.

A recommended termination circuit for the LVDS outputs is shown in Figure 21.

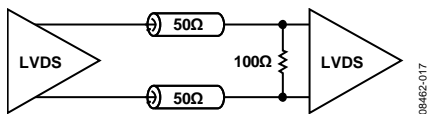

Figure 21. LVDS Output Termination

See the AN-586 Application Note on the Analog Devices website at [www.analog.com](http://www.analog.com) for more information about LVDS.

**LVC MOS CLOCK DISTRIBUTION**

The AD9575 provides a 33.33 MHz or 62.5 MHz clock output, which is a dedicated LVC MOS level. Whenever single-ended LVC MOS clocking is used, some of the following general guidelines should be followed.

Point-to-point nets should be designed such that a driver has only one receiver on the net, if possible. This allows for simple

termination schemes and minimizes ringing due to possible mismatched impedances on the net. Series termination at the source is generally required to provide transmission line matching and/or to reduce current transients at the driver (see Figure 22). The value of the resistor is dependent on the board design and timing requirements (typically 10 Ω to 100 Ω is used). LVC MOS outputs are limited in terms of the capacitive load or trace length that they can drive. Typically, trace lengths less than 6 inches are recommended to preserve signal rise/fall times and preserve signal integrity.

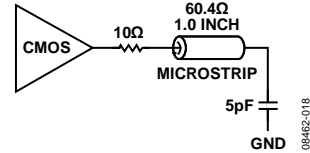

Figure 22. Series Termination of LVC MOS Output

Termination at the far end of the PCB trace is a second option. The LVC MOS output of the AD9575 does not supply enough current to provide a full voltage swing with a low impedance resistive, far-end termination, as shown in Figure 23. The far-end termination network should match the PCB trace impedance and provide the desired switching point.

The reduced signal swing may still meet receiver input requirements in some applications. This can be useful when driving long trace lengths on less critical nets.

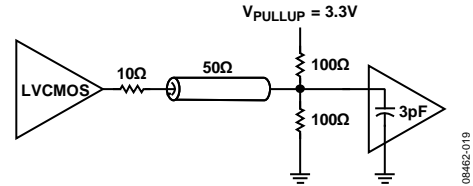

Figure 23. LVC MOS Output with Far-End Termination

**TYPICAL APPLICATION CIRCUIT**

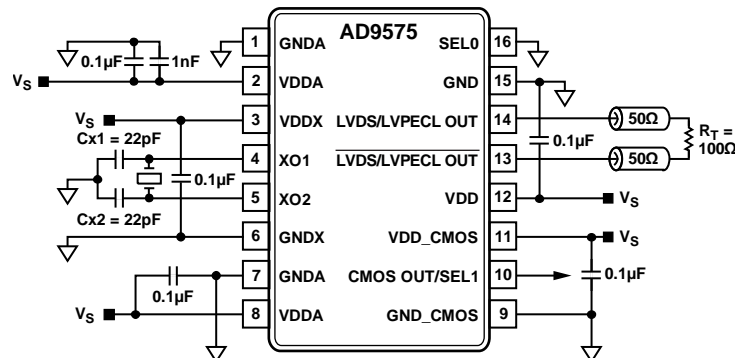
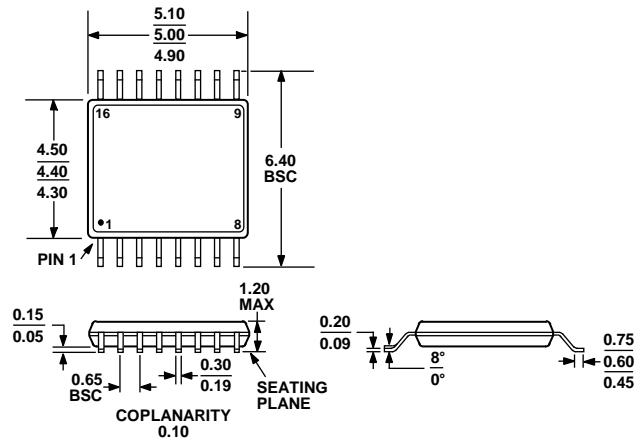

Figure 24. Typical Application Circuit (in LVDS Configuration)

# AD9575

## OUTLINE DIMENSIONS



COMPLIANT TO JEDEC STANDARDS MO-153-AB

Figure 25. 16-Lead Thin Shrink Small Outline Package [TSSOP]  
(RU-16)

Dimensions shown in millimeters

## ORDERING GUIDE

Model <sup>1</sup>	Temperature Range	Package Description	Package Option
AD9575ARUZLVD	-40°C to +85°C	16-Lead Thin Shrink Small Outline Package (TSSOP), 96 pcs per Tube, LVDS Output Format	RU-16
AD9575ARUZPEC	-40°C to +85°C	16-Lead Thin Shrink Small Outline Package (TSSOP), 96 pcs per Tube, LVPECL Output Format	RU-16
AD9575-EVALZ-LVD		LVDS Outputs, Evaluation Board	
AD9575-EVALZ-PEC		LVPECL Outputs, Evaluation Board	

<sup>1</sup> Z = RoHS Compliant Part.

**NOTES**

**AD9575**

**NOTES**

## Looking for pricing, stock, or lifecycle information?

Click below to explore more details on WIN SOURCE:

 [View AD9575ARUZLVD on WIN SOURCE](#)

 [Analog Devices Inc. Information](#)

## Optimize Your Supply Chain with WIN SOURCE Solutions

-  Global Sourcing Solution
-  Obsolete Management
-  Cost Control Management
-  Shortage Management
-  Alternative Solution
-  Excess Inventory Management