



**THE DATASHEET OF  
ADG794BRQZ-500RL7**



### FEATURES

**Bandwidth: 300 MHz**

**Low insertion loss and on resistance: 5  $\Omega$  typical**

**On-resistance flatness: 0.7  $\Omega$  typical**

**Single 3.3 V/5 V supply operation**

**Low quiescent supply current: 1 nA typical**

**Fast switching times**

$t_{ON}$ , 7 ns

$t_{OFF}$ , 5 ns

**TTL/CMOS compatible**

**ESD protection**

**2 kV human body model (HBM)**

**200 V machine model (MM)**

**1 kV field-induced charged device model (FICDM)**

### APPLICATIONS

**RGB switches**

**HDTV**

**DVD-R**

**Audio/video switches**

### GENERAL DESCRIPTION

The ADG794 is a monolithic CMOS device comprising four 2:1 multiplexers/demultiplexers with high impedance outputs. The CMOS process provides low power dissipation yet gives high switching speed and low on resistance. The on-resistance variation is less than 1.2  $\Omega$  over the input signal range.

The wide bandwidth of the ADG794 (300 MHz typical), coupled with low distortion (0.18% typical), makes the part suitable for switching analog audio/video signals.

The ADG794 operates from a single 3.3 V/5 V supply and is TTL logic compatible. The switches are controlled by the logic inputs IN and EN, as shown in Table 4. The  $\overline{EN}$  pin allows the user to disable all switches.

These switches conduct equally well in both directions when on. In the off condition, signal levels up to the supplies are blocked. The ADG794 switches exhibit break-before-make switching action. The ADG794 is available in a 16-lead QSOP.

### FUNCTIONAL BLOCK DIAGRAM

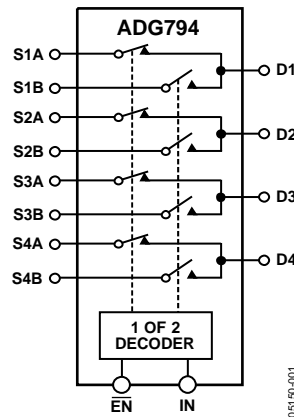

Figure 1.

### PRODUCT HIGHLIGHTS

1. Wide bandwidth: 300 MHz.
2. Ultralow power dissipation.
3. Crosstalk: -70 dB (typical) at 10 MHz.
4. Off isolation: -65 dB (typical) at 10 MHz.
5. ESD protection tested as per ESD Association Standards:  
2 kV HBM (ANSI/ESD STM5.1-2001)  
200 V MM (ANSI/ESD STM5.2-1999)  
1 kV FICDM (ANSI/ESD STM5.3.1-1999)

#### Rev. B

Information furnished by Analog Devices is believed to be accurate and reliable. However, no responsibility is assumed by Analog Devices for its use, nor for any infringements of patents or other rights of third parties that may result from its use. Specifications subject to change without notice. No license is granted by implication or otherwise under any patent or patent rights of Analog Devices. Trademarks and registered trademarks are the property of their respective owners.

**TABLE OF CONTENTS**

Features .....1  
Applications.....1  
Functional Block Diagram .....1  
General Description .....1  
Product Highlights .....1  
Revision History .....2  
Specifications.....3  
    Single Supply .....3  
Absolute Maximum Ratings.....5

ESD Caution .....5  
Pin Configuration and Function Descriptions .....6  
Terminology.....7  
Typical Performance Characteristics .....8  
Typical Application .....9  
Test Circuits .....10  
Outline Dimensions.....12  
    Ordering Guide .....12

**REVISION HISTORY**

**2/08—Rev A to Rev B**

Changes to Absolute Maximum Ratings Section, Table 3 ..... 5  
Updated Outline Dimensions ..... 12  
Changes to Ordering Guide ..... 12

**4/06—Rev. 0 to Rev. A**

Changes to Features Section ..... 1  
Changes to Product Highlights Section ..... 1  
Changes to Specifications Section.....3  
Changes to Typical Performance Characteristics .....8

**10/04—Revision 0: Initial Version**

# SPECIFICATIONS

## SINGLE SUPPLY

$V_{DD} = 5\text{ V} \pm 10\%$ ,  $GND = 0\text{ V}$ . All specifications  $T_{MIN}$  to  $T_{MAX}$ , unless otherwise noted.

Table 1.

Parameter	B Version <sup>1</sup>		Unit	Test Conditions/Comments
	25°C	$T_{MIN}$ to $T_{MAX}$		
<b>ANALOG SWITCH</b>				
Analog Signal Range		0 to 2.5	V	
On Resistance, $R_{ON}$	5		$\Omega$ typ	$V_D = 0\text{ V}$ to $1\text{ V}$ ; $I_S = -10\text{ mA}$ ; Figure 8
	7	8	$\Omega$ max	
On-Resistance Match Between Channels, $\Delta R_{ON}$	0.4		$\Omega$ typ	$V_D = 0\text{ V}$ to $1\text{ V}$ ; $I_S = -10\text{ mA}$
		1.2	$\Omega$ max	
On-Resistance Flatness, $R_{FLAT(ON)}$	0.7		$\Omega$ typ	$V_D = 0\text{ V}$ to $1\text{ V}$ ; $I_S = -10\text{ mA}$
		1.35	$\Omega$ max	
<b>LEAKAGE CURRENTS</b>				
Source Off Leakage, $I_S$ (Off)	$\pm 0.001$		nA typ	$V_S = 3\text{ V}/1\text{ V}$ ; $V_D = 1\text{ V}/3\text{ V}$ ; Figure 9
Drain Off Leakage, $I_D$ (Off)	$\pm 0.001$		nA typ	$V_S = 3\text{ V}/1\text{ V}$ ; $V_D = 1\text{ V}/3\text{ V}$ ; Figure 9
Channel On Leakage, $I_D, I_S$ (On)	$\pm 0.001$		nA typ	$V_D = V_S = 3\text{ V}/1\text{ V}$ ; Figure 10
<b>DIGITAL INPUTS</b>				
Input High Voltage, $V_{INH}$		2.0	V min	
Input Low Voltage, $V_{INL}$		0.8	V max	
Input Current				
$I_{INL}$ or $I_{INH}$	0.001		$\mu\text{A}$ typ	$V_{IN} = V_{INL}$ or $V_{INH}$
		$\pm 0.1$	$\mu\text{A}$ max	
Digital Input Capacitance, $C_{IN}$		3	pF typ	
<b>DYNAMIC CHARACTERISTICS<sup>2</sup></b>				
$t_{ON}, t_{ON}(\overline{EN})$	7		ns typ	$C_L = 35\text{ pF}$ ; $R_L = 50\ \Omega$
		14	ns max	$V_S = 2\text{ V}$ ; Figure 11
$t_{OFF}, t_{OFF}(\overline{EN})$	5		ns typ	$C_L = 35\text{ pF}$ ; $R_L = 50\ \Omega$
		8	ns max	$V_S = 2\text{ V}$ ; Figure 11
Break-Before-Make Time Delay, $t_D$	3		ns typ	$C_L = 35\text{ pF}$ ; $R_L = 50\ \Omega$
		1	ns min	$V_{S1} = V_{S2} = 2\text{ V}$ ; Figure 12
Off Isolation	-65		dB typ	$f = 10\text{ MHz}$ ; $R_L = 50\ \Omega$ ; Figure 14
Channel-to-Channel Crosstalk	-70		dB typ	$f = 10\text{ MHz}$ ; $R_L = 50\ \Omega$ ; Figure 15
Bandwidth -3 dB	300		MHz typ	$R_L = 50\ \Omega$ ; Figure 13
THD + N	0.18		% typ	$R_L = 100\ \Omega$
Charge Injection	7.5		pC typ	$C_L = 1\text{ nF}$ ; $V_S = 0\text{ V}$ ; Figure 16
$C_S$ (Off)	8		pF typ	
$C_D$ (Off)	14		pF typ	
$C_D, C_S$ (On)	23		pF typ	
<b>POWER REQUIREMENTS</b>				
$I_{DD}$	0.001		$\mu\text{A}$ typ	$V_{DD} = 5.5\text{ V}$ ; digital inputs = $0\text{ V}$ or $V_{DD}$
		1	$\mu\text{A}$ max	

<sup>1</sup> Temperature range for B version is  $-40^\circ\text{C}$  to  $+85^\circ\text{C}$ .

<sup>2</sup> Guaranteed by design, not subject to production test.

# ADG794

$V_{DD} = 3\text{ V} \pm 10\%$ ,  $GND = 0\text{ V}$ . All specifications  $T_{MIN}$  to  $T_{MAX}$ , unless otherwise noted.

**Table 2.**

Parameter	B Version <sup>1</sup>		Unit	Test Conditions/Comments
	25°C	$T_{MIN}$ to $T_{MAX}$		
<b>ANALOG SWITCH</b>				
Analogue Signal Range		0 to 1.5	V	
On Resistance, $R_{ON}$	7		$\Omega$ typ	$V_D = 0\text{ V}$ to $1\text{ V}$ ; $I_S = -10\text{ mA}$ ; Figure 8
	9.5	11	$\Omega$ max	
On-Resistance Match between Channels, $\Delta R_{ON}$	0.3		$\Omega$ typ	$V_D = 0\text{ V}$ to $1\text{ V}$ ; $I_S = -10\text{ mA}$
		0.9	$\Omega$ max	
On-Resistance Flatness, $R_{FLAT(ON)}$	2.6		$\Omega$ typ	$V_D = 0\text{ V}$ to $1\text{ V}$ ; $I_S = -10\text{ mA}$
		5	$\Omega$ max	
<b>LEAKAGE CURRENTS</b>				
Source Off Leakage, $I_S$ (Off)	$\pm 0.001$		nA typ	$V_S = 2\text{ V}/1\text{ V}$ ; $V_D = 1\text{ V}/2\text{ V}$ ; Figure 9
Drain Off Leakage, $I_D$ (Off)	$\pm 0.001$		nA typ	$V_S = 2\text{ V}/1\text{ V}$ ; $V_D = 1\text{ V}/2\text{ V}$ ; Figure 9
Channel On Leakage, $I_D, I_S$ (On)	$\pm 0.001$		nA typ	$V_D = V_S = 2\text{ V}/1\text{ V}$ ; Figure 10
<b>DIGITAL INPUTS</b>				
Input High Voltage, $V_{INH}$		2.0	V min	
Input Low Voltage, $V_{INL}$		0.8	V max	
Input Current				
$I_{INL}$ or $I_{INH}$	0.001		$\mu\text{A}$ typ	$V_{IN} = V_{INL}$ or $V_{INH}$
		$\pm 0.1$	$\mu\text{A}$ max	
Digital Input Capacitance, $C_{IN}$		3	pF typ	
<b>DYNAMIC CHARACTERISTICS<sup>2</sup></b>				
$t_{ON}, t_{ON}(\overline{EN})$	10		ns typ	$C_L = 35\text{ pF}$ ; $R_L = 50\ \Omega$
		16	ns max	$V_S = 1.5\text{ V}$ ; Figure 11
$t_{OFF}, t_{OFF}(\overline{EN})$	6		ns typ	$C_L = 35\text{ pF}$ ; $R_L = 50\ \Omega$
		10	ns max	$V_S = 1.5\text{ V}$ ; Figure 11
Break-Before-Make Time Delay, $t_D$	3		ns typ	$C_L = 35\text{ pF}$ ; $R_L = 50\ \Omega$
		1	ns min	$V_{S1} = V_{S2} = 1.5\text{ V}$ ; Figure 12
Off Isolation	-65		dB typ	$f = 10\text{ MHz}$ ; $R_L = 50\ \Omega$ ; Figure 14
Channel-to-Channel Crosstalk	-70		dB typ	$f = 10\text{ MHz}$ ; $R_L = 50\ \Omega$ ; Figure 15
Bandwidth -3 dB	300		MHz typ	$R_L = 50\ \Omega$ ; Figure 13
THD + N	0.18		% typ	$R_L = 100\ \Omega$
Charge Injection	4		pC typ	$C_L = 1\text{ nF}$ ; $V_S = 0\text{ V}$ ; Figure 16
$C_S$ (Off)	8		pF typ	
$C_D$ (Off)	14		pF typ	
$C_D, C_S$ (On)	23		pF typ	
<b>POWER REQUIREMENTS</b>				
$I_{DD}$	0.001		$\mu\text{A}$ typ	$V_{DD} = 3.3\text{ V}$ ; digital inputs = $0\text{ V}$ or $V_{DD}$
		1	$\mu\text{A}$ max	

<sup>1</sup> Temperature range for B version is  $-40^\circ\text{C}$  to  $+85^\circ\text{C}$ .

<sup>2</sup> Guaranteed by design, not subject to production test.

## ABSOLUTE MAXIMUM RATINGS

$T_A = 25^\circ\text{C}$ , unless otherwise noted.

**Table 3.**

Parameters	Ratings
$V_{DD}$ to GND	-0.3 V to +6 V
Analog, Digital Inputs <sup>1</sup>	-0.3 V to $V_{DD} + 0.3$ V or 30 mA, whichever occurs first
Continuous Current, S or D	100 mA
Peak Current, S or D	300 mA (pulsed at 1 ms, 10% duty cycle maximum)
Operating Temperature Range	
Industrial (B Version)	-40°C to +85°C
Storage Temperature Range	-65°C to +150°C
Junction Temperature	150°C
QSOP Package, Power Dissipation	566 mW
$\theta_{JA}$ Thermal Impedance	149.97°C/W
Lead Temperature, Soldering	
Reflow, Peak Temperature	260(+0/-5)°C
Time at Peak Temperature	20 sec to 40 sec

<sup>1</sup> Overvoltages at IN, S, or D are clamped by internal diodes. Current should be limited to the maximum ratings given.

Stresses above those listed under Absolute Maximum Ratings may cause permanent damage to the device. This is a stress rating only; functional operation of the device at these or any other conditions above those listed in the operational sections of this specification is not implied. Exposure to absolute maximum rating conditions for extended periods may affect device reliability.

Only one absolute maximum rating may be applied at any one time.

**Table 4. Truth Table**

EN	IN	D1	D2	D3	D4	Function
1	X	High-Z	High-Z	High-Z	High-Z	Disable
0	0	S1A	S2A	S3A	S4A	IN = 0
0	1	S1B	S2B	S3B	S4B	IN = 1

### ESD CAUTION



**ESD (electrostatic discharge) sensitive device.**

Charged devices and circuit boards can discharge without detection. Although this product features patented or proprietary protection circuitry, damage may occur on devices subjected to high energy ESD. Therefore, proper ESD precautions should be taken to avoid performance degradation or loss of functionality.

## PIN CONFIGURATION AND FUNCTION DESCRIPTIONS

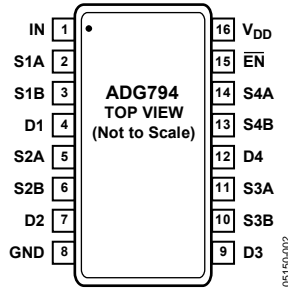

Figure 2. Pin Configuration

Table 5. Pin Function Descriptions

Pin NO.	Mnemonic	Description
1	IN	Logic Control Input. The logic level at this input controls the operation of the multiplexers (see Table 4).
2	S1A	A-Side Source Terminal of Mux1. Can be an input or an output.
3	S1B	B-Side Source Terminal of Mux1. Can be an input or an output.
4	D1	Drain Terminal of Mux1. Can be an input or an output.
5	S2A	A-Side Source Terminal of Mux2. Can be an input or an output.
6	S2B	B-Side Source Terminal of Mux2. Can be an input or an output.
7	D2	Drain Terminal of Mux2. Can be an input or an output.
8	GND	Ground Reference.
9	D3	Drain Terminal of Mux3. Can be an input or an output.
10	S3B	B-Side Source Terminal of Mux3. Can be an input or an output.
11	S3A	A-Side Source Terminal of Mux3. Can be an input or an output.
12	D4	Drain Terminal of Mux4. Can be an input or an output.
13	S4B	B-Side Source Terminal of Mux4. Can be an input or an output.
14	S4A	A-Side Source Terminal of Mux4. Can be an input or an output.
15	$\overline{\text{EN}}$	Mux Enable Logic Input. Enables or disables the multiplexers (see Table 4).
16	V <sub>DD</sub>	Positive Power Supply Voltage.

## TERMINOLOGY

### $V_{DD}$

Most positive power supply potential.

### $I_{DD}$

Positive supply current.

### GND

Ground (0 V) reference.

### S

Source terminal. Can be either an input or an output.

### D

Drain terminal. Can be either an input or an output.

### IN

Logic control input.

### $V_D$ ( $V_S$ )

Analog voltage on Terminal D and Terminal S.

### $R_{ON}$

Ohmic resistance between Terminal D and Terminal S.

### $R_{FLAT (ON)}$

Flatness is defined as the difference between the maximum and minimum value of on resistance as measured.

### $\Delta R_{ON}$

On-resistance match between any two channels.

### $I_S$ (Off)

Source leakage current with the switch off.

### $I_D$ (Off)

Drain leakage current with the switch off.

### $I_D, I_S$ (On)

Channel leakage current with the switch on.

### $V_{INL}$

Maximum input voltage for Logic 0.

### $V_{INH}$

Minimum input voltage for Logic 1.

### $I_{INL}$ ( $I_{INH}$ )

Input current of the digital input.

### $C_S$ (Off)

Off switch source capacitance. Measured with reference to ground.

### $C_D$ (Off)

Off switch drain capacitance. Measured with reference to ground.

### $C_D, C_S$ (On)

On switch capacitance. Measured with reference to ground.

### $C_{IN}$

Digital input capacitance.

### $t_{ON}$

Delay time between the 50% and the 90% points of the digital input and switch on condition.

### $t_{OFF}$

Delay time between the 50% and the 90% points of the digital input and switch off condition.

### $t_{BBM}$

On or off time measured between the 80% points of both switches when switching from one to another.

### Charge Injection

A measure of the glitch impulse transferred from the digital input to the analog output during on/off switching.

### Off Isolation

A measure of unwanted signal coupling through an off switch.

### Crosstalk

A measure of unwanted signal that is coupled through from one channel to another as a result of parasitic capacitance.

### -3 dB Bandwidth

The frequency at which the output is attenuated by 3 dB.

### On Response

The frequency response of the on switch.

### Insertion Loss

The loss due to the on resistance of the switch.

### THD + N

The ratio of the harmonic amplitudes plus the noise of a signal to the fundamental.

## TYPICAL PERFORMANCE CHARACTERISTICS

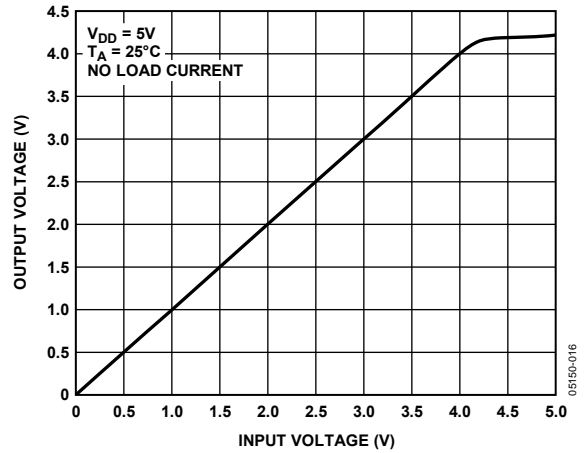
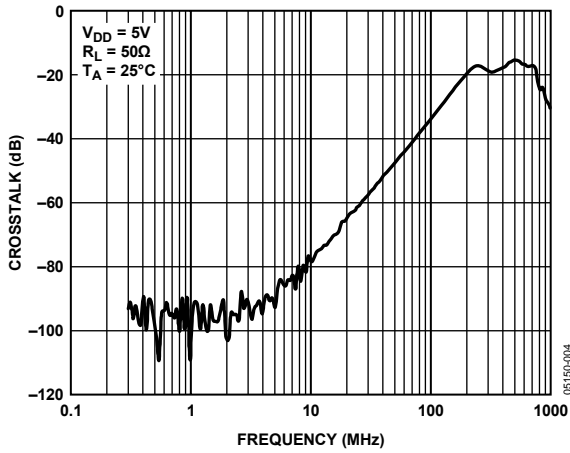
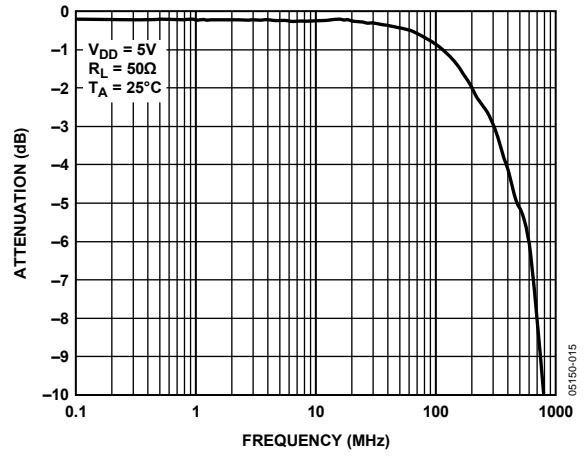
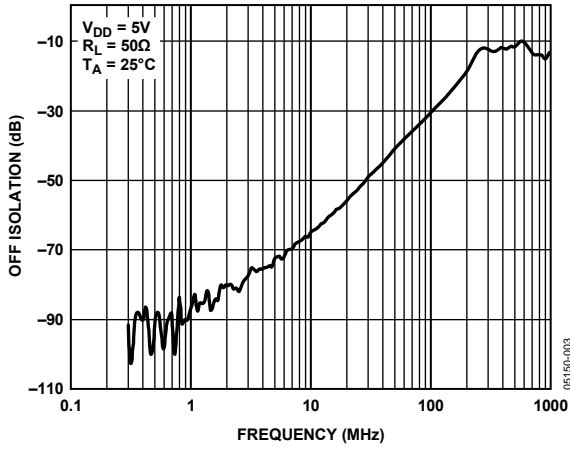

TYPICAL APPLICATION

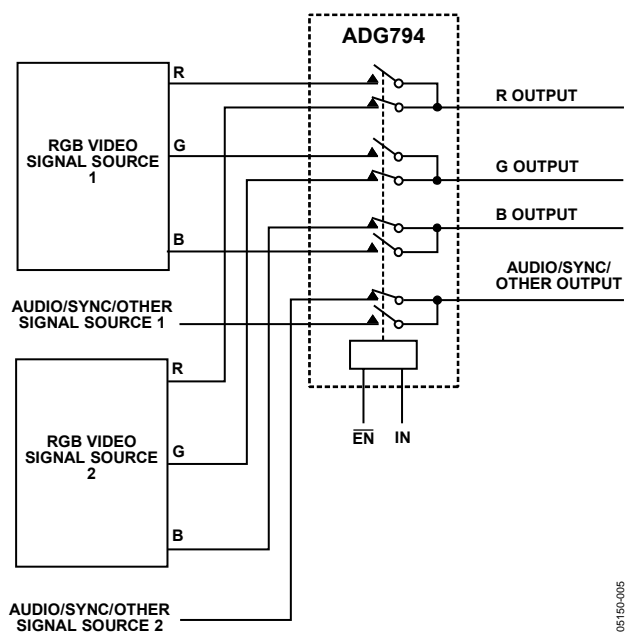

Figure 7. Audio/Video Switch

05150-005

## TEST CIRCUITS

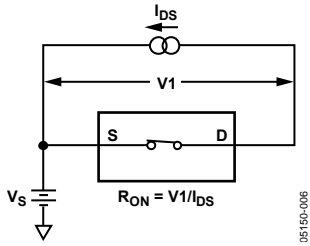

Figure 8. On Resistance

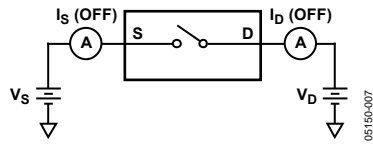

Figure 9. Off Leakage

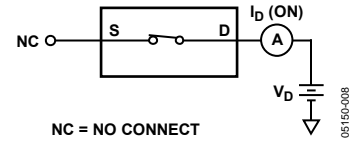

Figure 10. On Leakage

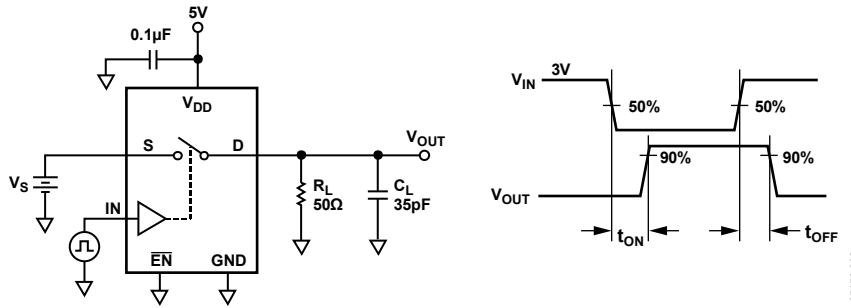

Figure 11. Switching Times

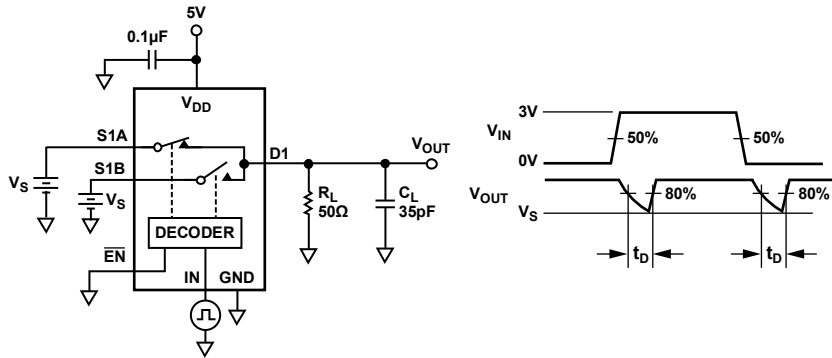

Figure 12. Break-Before-Make Time Delay

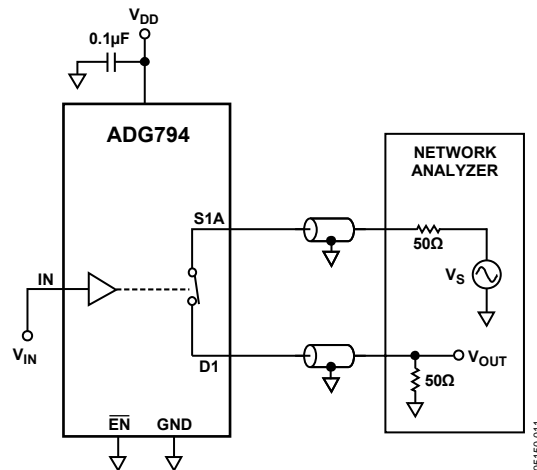

Figure 13. Bandwidth

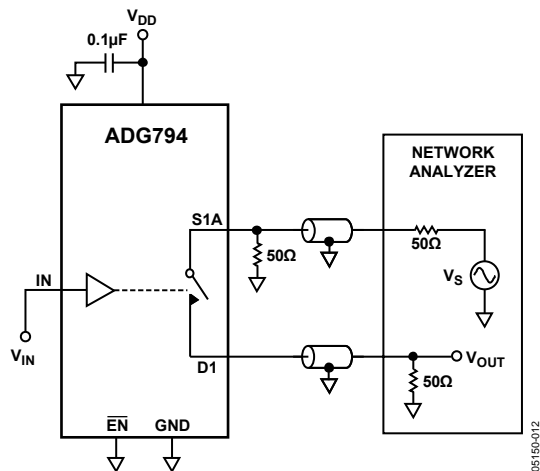

Figure 14. Off Isolation

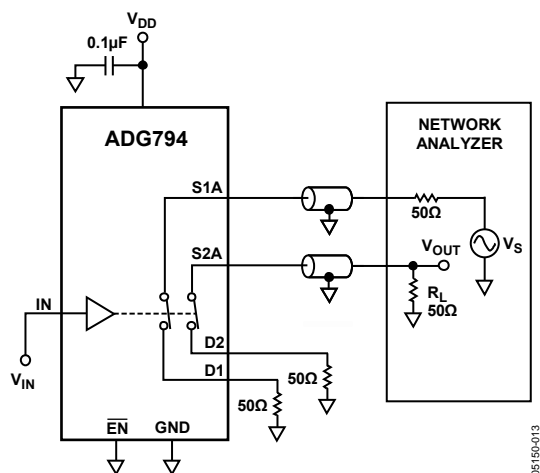

Figure 15. Channel-to-Channel Crosstalk

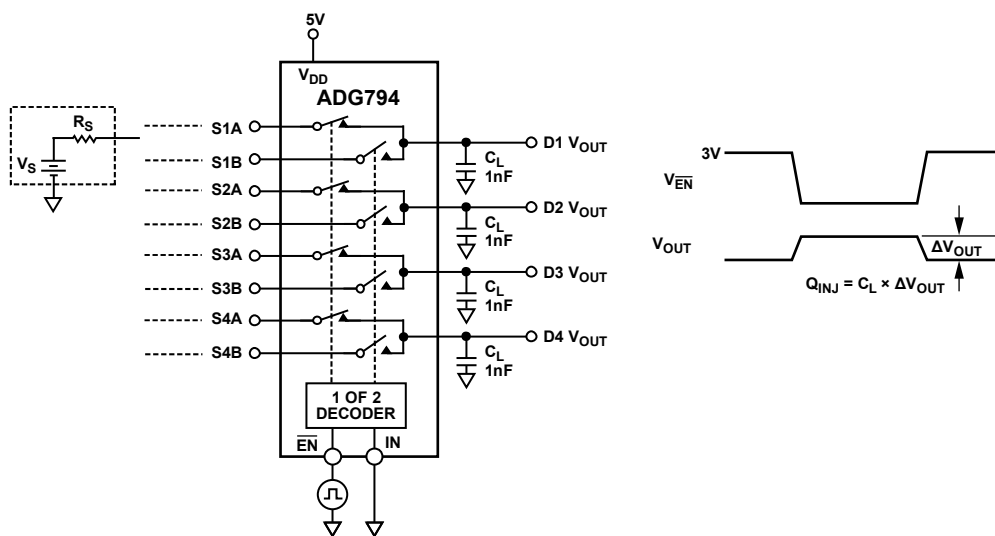
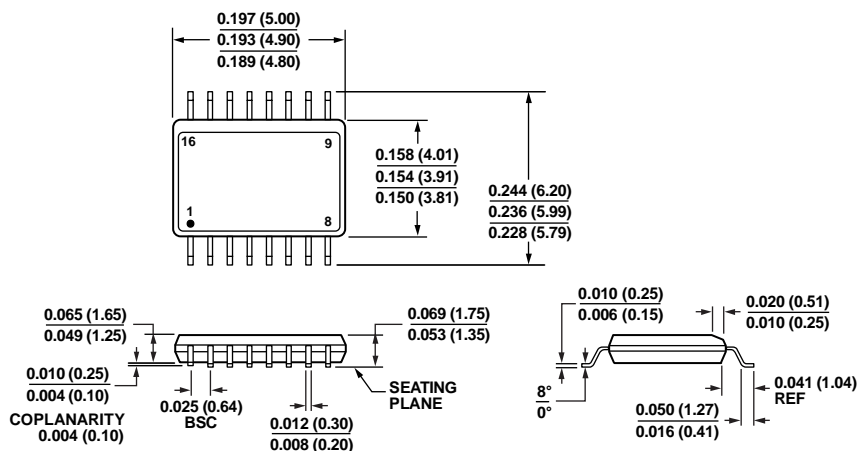

Figure 16. Charge Injection

# OUTLINE DIMENSIONS



COMPLIANT TO JEDEC STANDARDS MO-137-AB  
 CONTROLLING DIMENSIONS ARE IN INCHES; MILLIMETERS DIMENSIONS  
 (IN PARENTHESES) ARE ROUNDED-OFF INCH EQUIVALENTS FOR  
 REFERENCE ONLY AND ARE NOT APPROPRIATE FOR USE IN DESIGN.

Figure 17. 16-Lead Shrink Small Outline Package [QSOP]  
 (RQ-16)

Dimensions shown in inches and (millimeters)

012808-A

## ORDERING GUIDE

Model	Temperature Range	Package Description	Package Option
ADG794BRQZ <sup>1</sup>	-40°C to +85°C	16-Lead Shrink Small Outline Package (QSOP)	RQ-16
ADG794BRQZ-500RL7 <sup>1</sup>	-40°C to +85°C	16-Lead Shrink Small Outline Package (QSOP)	RQ-16
ADG794BRQZ-REEL <sup>1</sup>	-40°C to +85°C	16-Lead Shrink Small Outline Package (QSOP)	RQ-16
ADG794BRQZ-REEL7 <sup>1</sup>	-40°C to +85°C	16-Lead Shrink Small Outline Package (QSOP)	RQ-16

<sup>1</sup> Z = RoHS Compliant Part.

## Looking for pricing, stock, or lifecycle information?

Click below to explore more details on WIN SOURCE:

 [View ADG794BRQZ-500RL7 on WIN SOURCE](#)

 [Analog Devices Inc. Information](#)

## Optimize Your Supply Chain with WIN SOURCE Solutions

-  Global Sourcing Solution
-  Obsolete Management
-  Cost Control Management
-  Shortage Management
-  Alternative Solution
-  Excess Inventory Management