



**THE DATASHEET OF
ADIS16448BMLZ**



FEATURES

- Triaxial digital gyroscope with digital range scaling**
 $\pm 250^\circ/\text{sec}$, $\pm 500^\circ/\text{sec}$, $\pm 1000^\circ/\text{sec}$ settings
 Axis-to-axis alignment, $<0.05^\circ$
- Triaxial digital accelerometer, $\pm 18\text{ g}$ minimum**
- Triaxial digital magnetometer, ± 1.9 gauss minimum**
- Digital barometer, 10 mbar to 1200 mbar**
 Calibrated pressure range: 300 mbar to 1100 mbar
- Autonomous operation and data collection**
 No external configuration commands required
 205 ms start-up time
- Factory calibrated sensitivity, bias, and axial alignment**
 Calibration temperature range: -40°C to $+85^\circ\text{C}$
- SPI-compatible serial interface**
 Burst mode read sequence with optional CRC-16
- Embedded temperature sensor**
- Programmable operation and control**
 Automatic and manual bias correction controls
 Bartlett window FIR length, number of taps
 Digital I/O: data ready, alarm indicator, general-purpose
 Alarms for condition monitoring
 Enable external sample clock input up to 1.1 kHz
 Single command self test
- Single-supply operation: 3.15 V to 3.45 V**
- 2000 g shock survivability**
- Operating temperature range: -40°C to $+105^\circ\text{C}$**

APPLICATIONS

- Platform stabilization and control
- Navigation
- Robotics

GENERAL DESCRIPTION

The [ADIS16448](#) *iSensor*® device is a complete inertial system that includes a triaxial gyroscope, a triaxial accelerometer, a triaxial magnetometer, and pressure sensors. Each sensor in the [ADIS16448](#) combines industry-leading *iMEMS*® technology with signal conditioning that optimizes dynamic performance. The factory calibration characterizes each sensor for sensitivity, bias, and alignment. As a result, each sensor has its own dynamic compensation formulas that provide accurate sensor measurements.

The [ADIS16448](#) provides a simple, cost-effective method for integrating accurate, multi-axis inertial sensing into industrial systems, especially when compared with the complexity and investment associated with discrete designs. All necessary motion testing and calibration are part of the production process at the factory, greatly reducing system integration time. Tight orthogonal alignment simplifies inertial frame alignment in navigation systems. The SPI and register structures provide a simple interface for data collection and configuration control.

The [ADIS16448](#) has a compatible pinout for systems that currently use other Analog Devices, Inc., IMU products, such as [ADIS16334](#) or [ADIS16485](#). The [ADIS16448](#) is packaged in a module that is approximately 24.1 mm \times 37.7 mm \times 10.8 mm and has a standard connector interface.

FUNCTIONAL BLOCK DIAGRAM

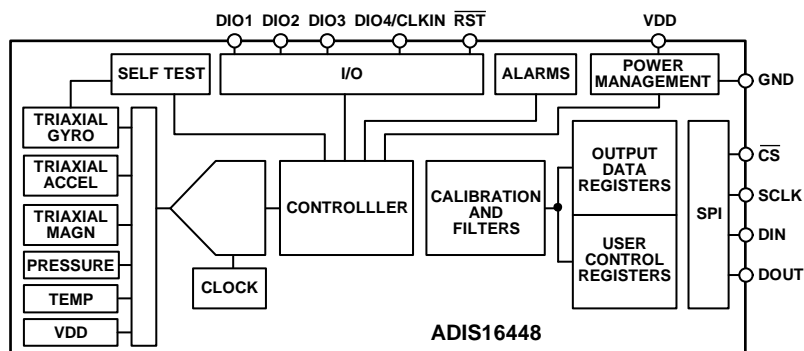

Figure 1.

Rev. H

[Document Feedback](#)

Information furnished by Analog Devices is believed to be accurate and reliable. However, no responsibility is assumed by Analog Devices for its use, nor for any infringements of patents or other rights of third parties that may result from its use. Specifications subject to change without notice. No license is granted by implication or otherwise under any patent or patent rights of Analog Devices. Trademarks and registered trademarks are the property of their respective owners.

One Technology Way, P.O. Box 9106, Norwood, MA 02062-9106, U.S.A.
 Tel: 781.329.4700 ©2012–2019 Analog Devices, Inc. All rights reserved.
[Technical Support](#) www.analog.com

TABLE OF CONTENTS

Features	1	Memory Management	17
Applications	1	Input/Output Configuration	18
General Description	1	Data Ready Indicator	18
Functional Block Diagram	1	General-Purpose Input/Output	18
Revision History	2	Digital Processing Configuration	19
Specifications	4	Gyroscopes/Accelerometers	19
Timing Specifications	6	Input Clock Configuration	19
Absolute Maximum Ratings	7	Magnetometer/Barometer	20
ESD Caution	7	Calibration	21
Pin Configuration and Function Descriptions	8	Gyroscopes	21
Typical Performance Characteristics	9	Accelerometers	21
User Registers	10	Magnetometer Calibration	22
User Interface	11	Flash Updates	23
Reading Sensor Data	11	Restoring Factory Calibration	23
Device Configuration	12	Alarms	24
Output Data Registers	13	Static Alarm Use	24
Gyroscopes	13	Dynamic Alarm Use	24
Accelerometers	13	Alarm Reporting	24
Magnetometers	14	Applications Information	25
Barometric Pressure	14	Mounting Tips	25
Remote Pressure Sensing	15	Power Supply Considerations	25
Internal Temperature	15	ADIS16IMU2/PCBZ	25
System Functions	16	PC-Based Evaluation Tools	25
Global Commands	16	X-Ray Sensitivity	25
Product Identification	16	Outline Dimensions	26
Self-Test Function	16	Ordering Guide	26
Status/Error Flags	17		
		Deleted Installation Section	27
REVISION HISTORY			
1/2019—Rev. G to Rev. H		8/2015—Rev. D to Rev. E	
Added Endnote 3, Table 1; Renumbered Sequentially	5	Change to Features Section	1
Changes to Digital Filtering Section	19	Changes to Input Sync Positive Pulse Width and Input Sync to Data Ready Valid Transition Parameters, Table 2	7
Added X-Ray Sensitivity Section	25	Changes to Figure 13 Caption	14
		Added Burst Read Function with CRC Section	14
5/2018—Rev. F to Rev. G		Changes to Figure 14	14
Changes to ADIS16IMU2/PCBZ Section and PC-Based Evaluation Tools Section	24	Changes to Table 30	18
4/2017—Rev. E to Rev. F			
Updated Layout	Universal	5/2015—Rev. C to Rev. D	
Changed ADIS16448/PCBZ Section to ADIS16IMU2/PCBZ Section	25	Changed ADIS16448AMLZ to ADIS16448BMLZ ... Throughout	
Changes to ADIS16IMU2/PCBZ Section, Figure 25, and Figure 26	25	Change to Features Section and General Description Section	1
Changes to Ordering Guide	26	Changes to Table 1	3
		Changes to Table 3	6

Change to Figure 910
 Changes to Ordering Guide.....23

9/2014—Rev. B to Rev. C

Changes to General Description Section 1
 Changes Status/Error Flags Section15
 Changes to Table 54.....21
 Added Mounting Tips Section22
7/2013—Rev. A to Rev. B
 Changes to Linear Acceleration Effect on Bias Test Conditions.....3
 Changes to Burst Read Function Section.....11

3/2013—Rev. 0 to Rev. A

Changed Start-Up Time from 192 ms to 205 ms..... 1
 Changes to Table 1 3
 Changed VDD from 5 V to 3.3 V, Changed t_{STALL} from $1/f_{SCLK}$ to N/A, and Added Endnote 2; Table 2..... 5
 Changes to Burst Read Function Section 11
 Changes to Table 23 13
 Changes to Single Command Bias Correction Section 19
 Changes to ADIS16448/PCBZ Section 22
 Deleted Mounting, Approaches Section 22
 Updated Outline Dimensions..... 23
 Changes to Ordering Guide..... 23

8/2012—Revision 0: Initial Version

SPECIFICATIONS

T_A = 25°C, VDD = 3.3 V, angular rate = 0°/sec, dynamic range = ±1000°/sec ± 1 g, unless otherwise noted.

Table 1.

Parameter	Test Conditions/Comments	Min	Typ	Max	Unit
GYROSCOPES					
Dynamic Range		±1000	±1200		°/sec
Initial Sensitivity	±1000°/sec, see Table 12		0.04		°/sec/LSB
	±500°/sec, see Table 12		0.02		°/sec/LSB
	±250°/sec, see Table 12		0.01		°/sec/LSB
Repeatability ¹	-40°C ≤ T _A ≤ +85°C			1	%
Sensitivity Temperature Coefficient	-40°C ≤ T _A ≤ +85°C		±40		ppm/°C
Misalignment	Axis to axis		±0.05		Degrees
	Axis to frame (package)		±0.5		Degrees
Nonlinearity	Best fit straight line		±0.1		% of FS
Bias Repeatability ^{1, 2}	-40°C ≤ T _A ≤ +85°C, 1 σ		0.5		°/sec
In-Run Bias Stability	1 σ, SMPL_PRD = 0x0001		14.5		°/hr
Angular Random Walk	1 σ, SMPL_PRD = 0x0001		0.66		°/√hr
Bias Temperature Coefficient	-40°C ≤ T _A ≤ +85°C		0.005		°/sec/°C
Linear Acceleration Effect on Bias	Any axis, 1 σ		0.015		°/sec/g
Bias Supply Sensitivity	-40°C ≤ T _A ≤ +85°C		0.2		°/sec/V
Output Noise	±1000°/sec range, no filtering		0.27		°/sec rms
Rate Noise Density	f = 25 Hz, ±1000°/sec range, no filtering		0.0135		°/sec/√Hz rms
-3 dB Bandwidth			330		Hz
Sensor Resonant Frequency			17.5		kHz
ACCELEROMETERS					
Dynamic Range	Each axis	±18			g
Sensitivity	See Table 16 for data format		0.833		mg/LSB
Repeatability ¹	-40°C ≤ T _A ≤ +85°C			1	%
Sensitivity Temperature Coefficient	-40°C ≤ T _A ≤ +85°C		±40		ppm/°C
Misalignment	Axis to axis		0.2		Degrees
	Axis to frame (package)		±0.5		Degrees
Nonlinearity	Best fit straight line		0.2		% of FS
Bias Repeatability ^{1, 2, 3}	-40°C ≤ T _A ≤ +85°C, 1 σ		20		mg
In-Run Bias Stability	1 σ, SMPL_PRD = 0x0001		0.25		mg
Velocity Random Walk	1 σ, SMPL_PRD = 0x0001		0.11		m/sec/√hr
Bias Temperature Coefficient	-40°C ≤ T _A ≤ +85°C		±0.15		mg/°C
Bias Supply Sensitivity	-40°C ≤ T _A ≤ +85°C		5		mg/V
Output Noise	No filtering		5.1		mg rms
Noise Density	No filtering		0.23		mg/√Hz rms
-3 dB Bandwidth			330		Hz
Sensor Resonant Frequency			5.5		kHz
MAGNETOMETERS					
Dynamic Range		±1.9			gauss
Initial Sensitivity	25°C, see Table 20 for data format	140.04	142.9	145.76	µgauss/LSB
Sensitivity Temperature Coefficient	Relative to 25°C, 1 σ		800		ppm/°C
Misalignment	Axis to axis		0.25		Degrees
	Axis to frame (package)		0.5		Degrees
Nonlinearity	Best fit straight line		0.1		% of FS
Initial Bias Error	25°C, 0 gauss stimulus		±4		mgauss
Bias Temperature Coefficient	-40°C ≤ T _A ≤ +85°C		0.11		mgauss/°C
Output Noise	25°C, no filtering, rms		2.4		mgauss
Noise Density	25°C, no filtering, rms		0.4		mgauss/√Hz
Bandwidth	-3 dB		25		Hz

Parameter	Test Conditions/Comments	Min	Typ	Max	Unit
TEMPERATURE					
Sensitivity	See Table 23		0.07386		°C/LSB
BAROMETERS					
Pressure Range, Operating		300		1100	mbar
Pressure Range Extended ⁴		10		1200	mbar
Sensitivity			0.02		mbar/LSB
Voltage Dependence			0.18		%/V
Bias Supply Voltage Sensitivity			3.24		mbar/V
Total Error	25°C, 300 mbar to 1100 mbar		1.5		mbar
Relative Error ⁵	–40°C to +85°C, 300 mbar to 1100 mbar		2.5		mbar
Linearity ⁶	25°C, 300 mbar to 1100 mbar		0.1		% of FS
	–40°C to +85°C, 300 mbar to 1100 mbar		0.2		% of FS
Noise			0.08		mbar rms
LOGIC INPUTS ⁷					
Input High Voltage, V _{IH}		2.0			V
Input Low Voltage, V _{IL}				0.8	V
Logic 1 Input Current, I _{IH}	V _{IH} = 3.3 V		±0.2	±10	µA
Logic 0 Input Current, I _{IL}	V _{IL} = 0 V				
All Pins Except $\overline{\text{RST}}$			40	60	µA
$\overline{\text{RST}}$ Pin			1		mA
Input Capacitance, C _{IN}			10		pF
DIGITAL OUTPUTS ⁷					
Output High Voltage, V _{OH}	I _{SOURCE} = 1.6 mA	2.4			V
Output Low Voltage, V _{OL}	I _{SINK} = 1.6 mA			0.4	V
FLASH MEMORY					
Data Retention ⁹	Endurance ⁸ T _J = 85°C	10,000 20			Cycles Years
FUNCTIONAL TIMES ¹⁰	Time until new data is available				
Power-On Start-Up Time			205		ms
Reset Recovery Time ¹¹			90		ms
Flash Memory Back-Up Time			75		ms
Flash Memory Test Time			20		ms
Automatic Self-Test Time	SMPL_PRD = 0x0001		45		ms
CONVERSION RATE					
xGYRO_OUT, xACCL_OUT	SMPL_PRD = 0x0001		819.2		SPS
xMAGN_OUT, BARO_OUT ¹²	SMPL_PRD = 0x0001		51.2		SPS
Clock Accuracy				±3	%
Sync Input Clock ¹³		0.8		1.1	kHz
POWER SUPPLY					
Power Supply Current	Operating voltage range, VDD	3.15	3.3	3.45	V
			76	104	mA

¹ The repeatability specifications represent analytical projections, which are based off of the following drift contributions and conditions: temperature hysteresis (–40°C to +85°C), electronics drift (high-temperature operating life test: 85°C, 500 hours), drift from temperature cycling (JESD22, Method A104-C, Method N, 500 cycles, –40°C to +85°C), rate random walk (10 year projection), and broadband noise.

² Bias repeatability describes a long-term behavior, over a variety of conditions. Short-term repeatability is related to the in-run bias stability and noise density specifications.

³ X-ray exposure may degrade this performance metric.

⁴ The extended pressure range is guaranteed by design.

⁵ The relative error assumes that the initial error, at 25°C, is corrected in the end application.

⁶ Linearity errors assume a full scale (FS) of 1000 mbar.

⁷ The digital I/O signals are driven by an internal 3.3 V supply, and the inputs are 5 V tolerant.

⁸ Endurance is qualified as per JEDEC Standard 22, Method A117, and measured at –40°C, +25°C, +85°C, and +125°C.

⁹ The data retention lifetime equivalent is at a junction temperature (T_J) of 85°C as per JEDEC Standard 22, Method A117. Data retention lifetime decreases with junction temperature.

¹⁰ These times do not include thermal settling and internal filter response times (330 Hz bandwidth), which may affect overall accuracy.

¹¹ The $\overline{\text{RST}}$ line must be held low for at least 10 µs to assure a proper reset and recovery sequence.

¹² The xMAGN_OUT and BARO_OUT registers update at a rate that is 1/16th that of the other output registers.

¹³ The sync input clock functions below the specified minimum value but at reduced performance levels.

TIMING SPECIFICATIONS

T_A = 25°C, VDD = 3.3 V, unless otherwise noted.

Table 2.

Parameter	Description	Normal Mode			Burst Read			Unit
		Min ¹	Typ	Max	Min ¹	Typ	Max	
f _{SCLK}	Serial clock	0.01		2.0	0.01		1.0	MHz
t _{STALL}	Stall period between data	9			N/A ²			μs
t _{READRATE}	Read rate	40						μs
t _{CS}	Chip select to SCLK edge	48.8			48.8			ns
t _{DAV}	DOUT valid after SCLK edge			100			100	ns
t _{DSU}	DIN setup time before SCLK rising edge	24.4			24.4			ns
t _{DHD}	DIN hold time after SCLK rising edge	48.8			48.8			ns
t _{SCLKR} , t _{SCLKF}	SCLK rise/fall times, not shown in the Timing Diagrams section		5	12.5		5	12.5	ns
t _{DR} , t _{DF}	DOUT rise/fall times, not shown in the Timing Diagrams section		5	12.5		5	12.5	ns
t _{SFS}	\overline{CS} high after SCLK edge	5			5			ns
t ₁	Input sync positive pulse width	25			25			μs
t _{STDR}	Input sync to data ready valid transition		600			600		μs
t _{NV}	Data invalid time		210			210		μs
t ₃	Input sync period	910			910			μs

¹ Guaranteed by design and characterization, but not tested in production.

² When using the burst read mode, the stall period is not applicable.

Timing Diagrams

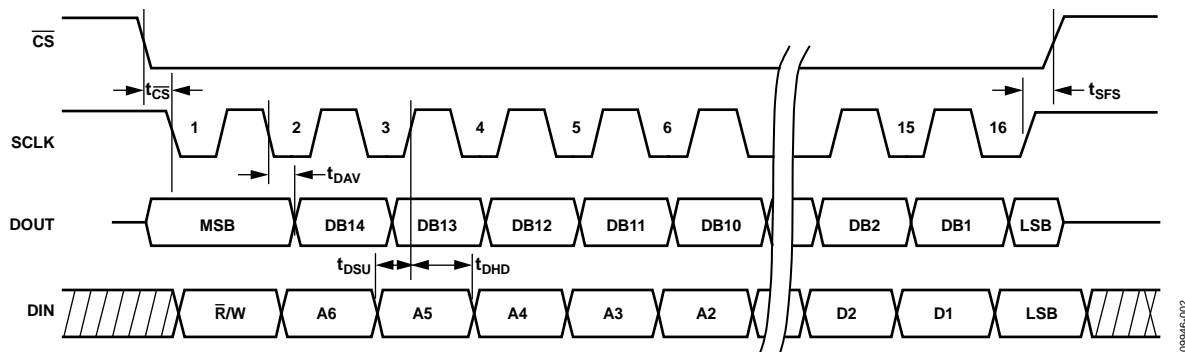

Figure 2. SPI Timing and Sequence

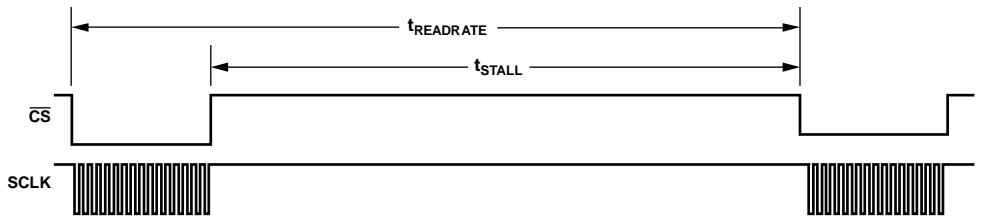

Figure 3. Stall Time and Data Rate

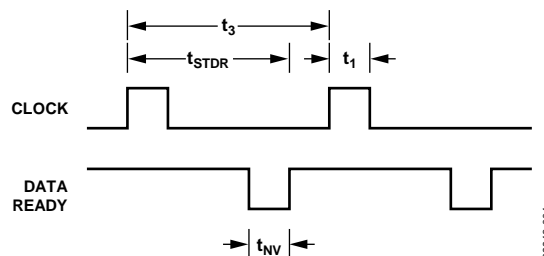

Figure 4. Input Clock Timing Diagram

ABSOLUTE MAXIMUM RATINGS

Table 3.

Parameter	Rating
Acceleration	
Any Axis, Unpowered	2000 <i>g</i>
Any Axis, Powered	2000 <i>g</i>
VDD to GND	−0.3 V to +3.45 V
Digital Input Voltage to GND	−0.3 V to +VDD + 0.3 V
Digital Output Voltage to GND	−0.3 V to +VDD + 0.3 V
Temperature	
Operating Range	−40°C to +105°C
Storage Range	−65°C to +125°C ^{1,2}
Pressure	2 bar

¹ Extended exposure to temperatures outside the specified temperature range of −40°C to +105°C can adversely affect the accuracy of the factory calibration. For best accuracy, store the parts within the specified operating range of −40°C to +105°C.

² Although the device is capable of withstanding short-term exposure to 150°C, long-term exposure threatens internal mechanical integrity.

Stresses at or above those listed under Absolute Maximum Ratings may cause permanent damage to the product. This is a stress rating only; functional operation of the product at these or any other conditions above those indicated in the operational section of this specification is not implied. Operation beyond the maximum operating conditions for extended periods may affect product reliability.

Table 4. Package Characteristics

Package Type	θ_{JA} (°C/W)	θ_{JC} (°C/W)	Mass (grams)
20-Lead Module (ML-20-2)	36.5	16.9	15

ESD CAUTION



ESD (electrostatic discharge) sensitive device. Charged devices and circuit boards can discharge without detection. Although this product features patented or proprietary protection circuitry, damage may occur on devices subjected to high energy ESD. Therefore, proper ESD precautions should be taken to avoid performance degradation or loss of functionality.

PIN CONFIGURATION AND FUNCTION DESCRIPTIONS

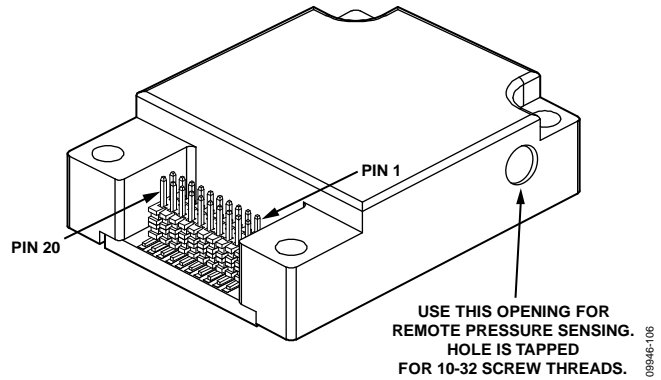
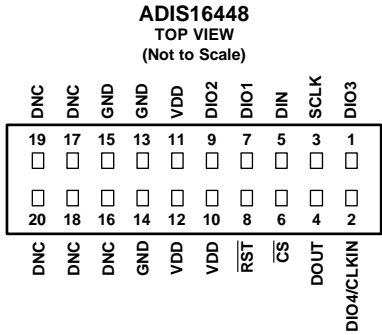

- NOTES**
1. THIS REPRESENTATION DISPLAYS THE TOP VIEW WHEN THE CONNECTOR IS VISIBLE AND FACING UP.
 2. MATING CONNECTOR: SAMTEC CLM-110-02 OR EQUIVALENT.
 3. DNC = DO NOT CONNECT.

Figure 5. Pin Configuration

Figure 6. Pin Locations

Table 5. Pin Function Descriptions

Pin No.	Mnemonic	Type ¹	Description
1	DIO3	I/O	Configurable Digital Input/Output.
2	DIO4/CLKIN	I/O	Configurable Digital Input/Output or Sync Clock Input.
3	SCLK	I	SPI Serial Clock.
4	DOUT	O	SPI Data Output. Clocks the output on the SCLK falling edge.
5	DIN	I	SPI Data Input. Clocks the input on the SCLK rising edge.
6	CS	I	SPI Chip Select.
7	DIO1	I/O	Configurable Digital Input/Output.
8	RST	I	Reset.
9	DIO2	I/O	Configurable Digital Input/Output.
10, 11, 12	VDD	S	Power Supply.
13, 14, 15	GND	S	Power Ground.
16, 17, 18, 19, 20	DNC	N/A	Do Not Connect. Do not connect to these pins.

¹ I is input, O is output, S is supply, and N/A is not applicable.

TYPICAL PERFORMANCE CHARACTERISTICS

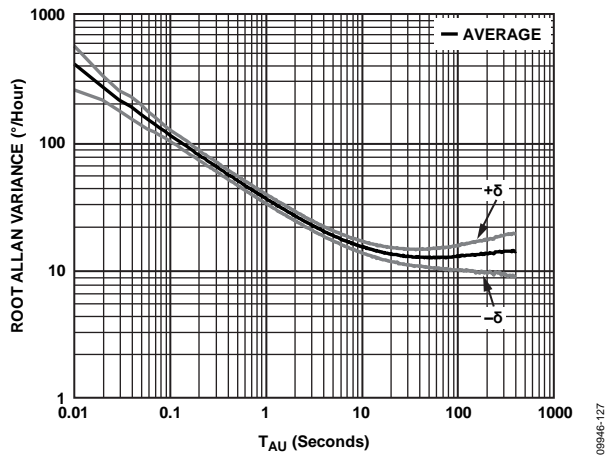

Figure 7. Gyroscope Root Allan Variance

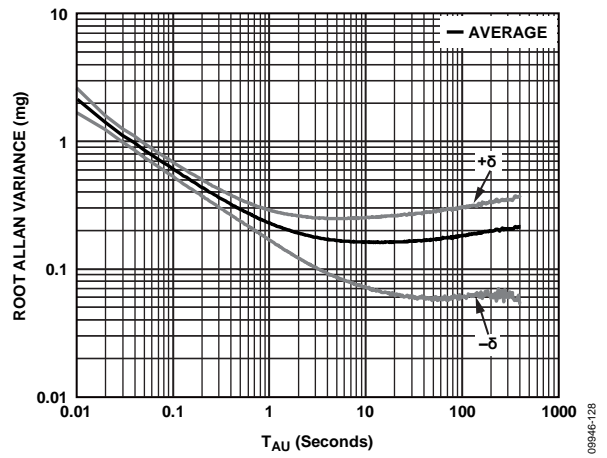

Figure 8. Accelerometer Root Allan Variance

USER REGISTERS

Table 6. User Register Memory Map¹

Name	R/W	Flash Backup	Address ²	Default	Function	Bit Assignments
FLASH_CNT	R	Yes	0x00	N/A	Flash memory write count	See Table 32
Reserved	N/A	N/A	0x02	N/A	N/A	
XGYRO_OUT	R	No	0x04	N/A	X-axis gyroscope output	See Table 9
YGYRO_OUT	R	No	0x06	N/A	Y-axis gyroscope output	See Table 10
ZGYRO_OUT	R	No	0x08	N/A	Z-axis gyroscope output	See Table 11
XACCL_OUT	R	No	0x0A	N/A	X-axis accelerometer output	See Table 13
YACCL_OUT	R	No	0x0C	N/A	Y-axis accelerometer output	See Table 14
ZACCL_OUT	R	No	0x0E	N/A	Z-axis accelerometer output	See Table 15
XMAGN_OUT	R	No	0x10	N/A	X-axis magnetometer measurement	See Table 17
YMAGN_OUT	R	No	0x12	N/A	Y-axis magnetometer measurement	See Table 18
ZMAGN_OUT	R	No	0x14	N/A	Z-axis magnetometer measurement	See Table 19
BARO_OUT	R	No	0x16	N/A	Barometer pressure measurement, high word	See Table 21
TEMP_OUT	R	No	0x18	N/A	Temperature output	See Table 23
XGYRO_OFF	R/W	Yes	0x1A	0x0000	X-axis gyroscope bias offset factor	See Table 37
YGYRO_OFF	R/W	Yes	0x1C	0x0000	Y-axis gyroscope bias offset factor	See Table 38
ZGYRO_OFF	R/W	Yes	0x1E	0x0000	Z-axis gyroscope bias offset factor	See Table 39
XACCL_OFF	R/W	Yes	0x20	0x0000	X-axis acceleration bias offset factor	See Table 40
YACCL_OFF	R/W	Yes	0x22	0x0000	Y-axis acceleration bias offset factor	See Table 41
ZACCL_OFF	R/W	Yes	0x24	0x0000	Z-axis acceleration bias offset factor	See Table 42
XMAGN_HIC	R/W	Yes	0x26	0x0000	X-axis magnetometer, hard iron factor	See Table 43
YMAGN_HIC	R/W	Yes	0x28	0x0000	Y-axis magnetometer, hard iron factor	See Table 44
ZMAGN_HIC	R/W	Yes	0x2A	0x0000	Z-axis magnetometer, hard iron factor	See Table 45
XMAGN_SIC	R/W	Yes	0x2C	0x0000	X-axis magnetometer, soft iron factor	See Table 46
YMAGN_SIC	R/W	Yes	0x2E	0x0000	Y-axis magnetometer, soft iron factor	See Table 47
ZMAGN_SIC	R/W	Yes	0x30	0x0000	Z-axis magnetometer, soft iron factor	See Table 48
GPIO_CTRL	R/W	No	0x32	0x0000	Auxiliary digital input/output control	See Table 33
MSC_CTRL	R/W	Yes	0x34	0x0006	Miscellaneous control	See Table 30
SMPL_PRD	R/W	Yes	0x36	0x0001	Internal sample period (rate) control	See Table 34
SENS_AVG	R/W	Yes	0x38	0x0402	Dynamic range and digital filter control	See Table 35
SEQ_CNT	R	N/A	0x3A	N/A	xMAGN_OUT and BARO_OUT counter	See Table 36
DIAG_STAT	R	No	0x3C	0x0000	System status	See Table 31
GLOB_CMD	W	N/A	0x3E	0x0000	System command	See Table 25
ALM_MAG1	R/W	Yes	0x40	0x0000	Alarm 1 amplitude threshold	See Table 49
ALM_MAG2	R/W	Yes	0x42	0x0000	Alarm 2 amplitude threshold	See Table 50
ALM_SMPL1	R/W	Yes	0x44	0x0000	Alarm 1 sample size	See Table 51
ALM_SMPL2	R/W	Yes	0x46	0x0000	Alarm 2 sample size	See Table 52
ALM_CTRL	R/W	Yes	0x48	0x0000	Alarm control	See Table 53
Reserved	N/A	N/A	0x4A to 0x51	N/A	Reserved	
LOT_ID1	R	Yes	0x52	N/A	Lot identification number	See Table 26
LOT_ID2	R	Yes	0x54	N/A	Lot identification number	See Table 27
PROD_ID	R	Yes	0x56	0x4040	Product identifier	See Table 28
SERIAL_NUM	R	Yes	0x58	N/A	Lot-specific serial number	See Table 29

¹ N/A means not applicable.

² Each register contains two bytes. The address of the lower byte is displayed. The address of the upper byte is equal to the address of the lower byte plus 1.

USER INTERFACE

The ADIS16448 is an autonomous system that requires no user initialization. When it has a valid power supply, it initializes itself and starts sampling, processing, and loading sensor data into the output registers at a sample rate of 819.2 SPS. DIO1 pulses high after each sample cycle concludes. The SPI interface enables simple integration with many embedded processor platforms, as shown in Figure 9 (electrical connection) and Table 7 (pin functions).

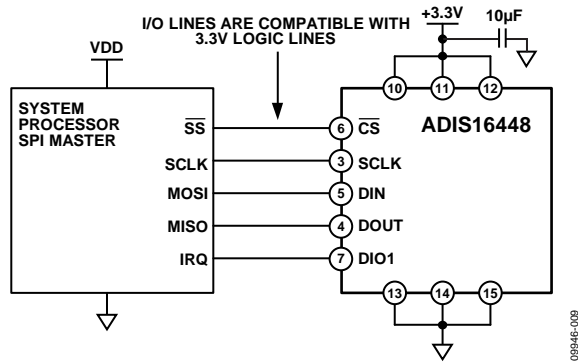

Figure 9. Electrical Connection Diagram

Table 7. Generic Master Processor Pin Names and Functions

Pin Name	Function
SS	Slave select
SCLK	Serial clock
MOSI	Master output, slave input
MISO	Master input, slave output
IRQ	Interrupt request

The ADIS16448 SPI interface supports full duplex serial communication (simultaneous transmit and receive) and uses the bit sequence shown in Figure 12. Table 8 provides a list of the most common settings that require attention to initialize the serial port of a processor for the ADIS16448 SPI interface.

Table 8. Generic Master Processor SPI Settings

Processor Setting	Description
Master	The ADIS16448 operates as a slave
SCLK Rate ≤ 2 MHz ¹	Maximum serial clock rate
SPI Mode 3	CPOL = 1 (polarity), CPHA = 1 (phase)
MSB-First Mode	Bit sequence
16-Bit Mode	Shift register/data length

¹ For burst read, SCLK rate ≤ 1 MHz.

READING SENSOR DATA

The ADIS16448 provides two different options for acquiring sensor data: single register and burst register. A single register read requires two 16-bit SPI cycles. The first cycle requests the contents of a register using the bit assignments in Figure 12. Bit DC7 to Bit DC0 are don't cares for a read, and then the output register contents follow on DOUT during the second sequence. Figure 10 includes three single register reads in succession. In this example, the process starts with DIN = 0x0400 to request the contents of XGYRO_OUT, then follows with 0x0600 to request YGYRO_OUT and 0x0800 to request ZGYRO_OUT. Full duplex operation enables processors to use the same 16-bit SPI cycle to read data from DOUT while requesting the next set of data on DIN. Figure 11 provides an example of the four SPI signals when reading XGYRO_OUT in a repeating pattern.

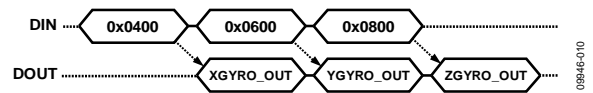

Figure 10. SPI Read Example

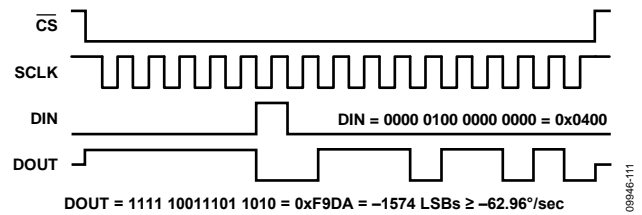
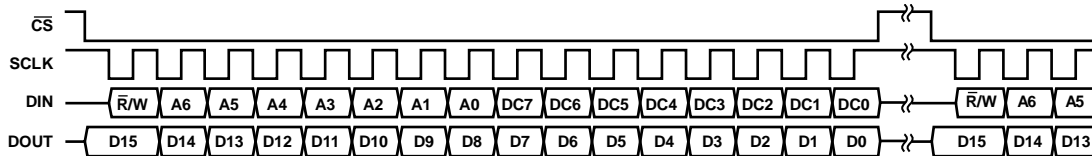

Figure 11. Example SPI Read, Second 16-Bit Sequence



NOTES

1. THE DOUT BIT PATTERN REFLECTS THE ENTIRE CONTENTS OF THE REGISTER IDENTIFIED BY [A6:A0] IN THE PREVIOUS 16-BIT DIN SEQUENCE WHEN R/W = 0.
2. IF R/W = 1 DURING THE PREVIOUS SEQUENCE, DOUT IS NOT DEFINED.

Figure 12. SPI Communication Bit Sequence

Burst Read Function

The burst read function provides a way to read all of the data in one continuous stream of bits (no stall time). As shown in Figure 13, start this mode by setting DIN = 0x3E00, while keeping CS low for 12 additional, 16-bit read cycles. These 12 cycles produce the following sequence of output registers on DOUT: DIAG_STAT, XGYRO_OUT, YGYRO_OUT, ZGYRO_OUT, XACCL_OUT, YACCL_OUT, ZACCL_OUT, XMAGN_OUT, YMAGN_OUT, ZMAGN_OUT, BARO_OUT, and TEMP_OUT.

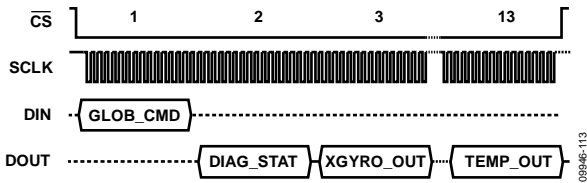

Figure 13. Burst Read Sequence, MSC_CTRL[4] = 0

Burst Read Function with CRC

When MSC_CTRL[4] = 1, the ADIS16448 adds a CRC-16 code at the end of the burst mode response (after TEMP_OUT), on the DOUT line. This increases the total number of 16-bit segments in the burst read operation to 14. The CRC-16 code derives from the CCIT CRC-16 method and provides a simple mechanism for verifying the correct communication of data during a burst mode sequence. This method strings together the data from the burst read output into a continuous binary number (176 bits), divides it by 0x1021, and uses the remainder of this operation as the CRC-16 code. The 176-bit binary number contains the contents of the following registers, which are in their order of significance in the 176-bit number: XGYRO_OUT (most significant 16-bits), YGYRO_OUT, ZGYRO_OUT, XACCL_OUT, YACCL_OUT, ZACCL_OUT, XMAGN_OUT, YMAGN_OUT, ZMAGN_OUT, BARO_OUT, and TEMP_OUT (least significant 16-bits).

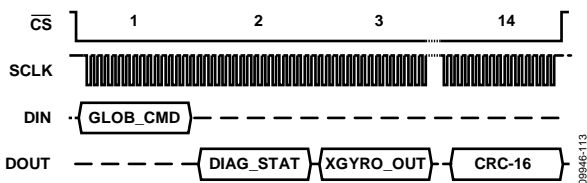

Figure 14. Burst Ready Sequence, MSC_CTRL[4] = 1

SPI Read Test Sequence

Figure 15 provides a test pattern for testing the SPI communication. In this pattern, write 0x5600 to the DIN line in a repeating pattern and raise chip select for at least 9 μs between each 16-bit sequence. Starting with the second 16-bit sequence, DOUT produces the contents of the PROD_ID (see Table 28) register, 0x4040.

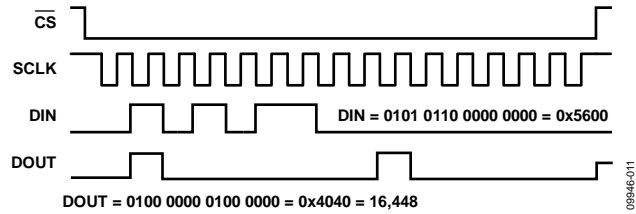

Figure 15. SPI Test Read Pattern DIN = 0x5600, DOUT = 0x4040

DEVICE CONFIGURATION

The control registers in Table 6 provide users with a variety of configuration options. The SPI provides access to these registers, one byte at a time, using the bit assignments in Figure 12. Each register has 16 bits, where Bits[7:0] represent the lower address, and Bits[15:8] represent the upper address. Figure 16 provides an example of writing 0x04 to Address 0x36 (SMPL_PRD[15:8]), using DIN = 0xB704. This example reduces the sample rate by a factor of eight (see Table 34).

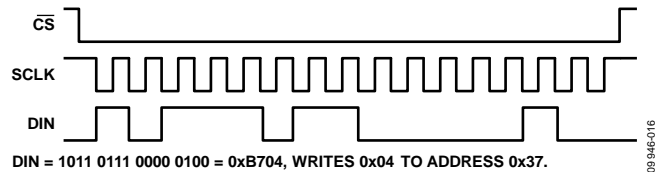

Figure 16. Example SPI Write Sequence

Dual Memory Structure

Writing configuration data to a control register updates its SRAM contents, which are volatile. After optimizing each relevant control register setting in a system, set GLOB_CMD[3] = 1 (DIN = 0xBE08) to backup these settings in nonvolatile flash memory. The flash backup process requires a valid power supply level for the entire process time, 75 ms. Table 6 provides a user register memory map that includes a flash backup column. A yes in this column indicates that a register has a mirror location in flash and, when backed up properly, it automatically restores itself during startup or after a reset. Figure 17 provides a diagram of the dual memory structure used to manage operation and store critical user settings.

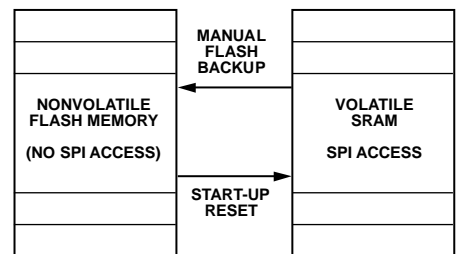

Figure 17. SRAM and Flash Memory Diagram

OUTPUT DATA REGISTERS

Each sensor in the ADIS16448 has a dedicated output register in the user register map (see Table 6). Figure 18 provides arrows, which describe the direction or rotation (g_x , g_y , g_z), acceleration (a_x , a_y , a_z), and magnetic field (m_x , m_y , m_z) that produce a positive response in its output data.

GYROSCOPES

XGYRO_OUT (see Table 9) contains x-axis gyroscope data (g_x in Figure 18), YGYRO_OUT (see Table 10) contains y-axis gyroscope data (g_y in Figure 18), and ZGYRO_OUT (see Table 11) contains z-axis gyroscope data (g_z in Figure 18). Table 12 illustrates the gyroscope data format with numerical examples.

Table 9. XGYRO_OUT (Base Address = 0x04), Read Only

Bits	Description
[15:0]	X-axis gyroscope data, twos complement format, 25 LSB/°/sec (SENS_AVG[15:8] = 0x04), 0°/sec = 0x0000

Table 10. YGYRO_OUT (Base Address = 0x06), Read Only

Bits	Description
[15:0]	Y-axis gyroscope data, twos complement format, 25 LSB/°/sec (SENS_AVG[15:8] = 0x04), 0°/sec = 0x0000

Table 11. ZGYRO_OUT (Base Address = 0x08), Read Only

Bits	Description
[15:0]	Z-axis gyroscope data, twos complement format, 25 LSB/°/sec (SENS_AVG[15:8] = 0x04), 0°/sec = 0x0000

Table 12. Rotation Rate, Twos Complement Format¹

Rotation Rate (°/sec)	Decimal	Hex	Binary
+1000	+25,000	0x61A8	0110 0001 1010 1000
+2 ÷ 25	+2	0x0002	0000 0000 0000 0010
+1 ÷ 25	+1	0x0001	0000 0000 0000 0001
0	0	0x0000	0000 0000 0000 0000
-1 ÷ 25	-1	0xFFFF	1111 1111 1111 1111
-2 ÷ 25	-2	0xFFFE	1111 1111 1111 1110
-1000	-25,000	0x9E58	1001 1110 0101 1000

¹ SENS_AVG[15:8] = 0x04, see Table 35.

ACCELEROMETERS

XACCL_OUT (see Table 13) contains x-axis accelerometer data (a_x in Figure 18), YACCL_OUT (see Table 14) contains y-axis accelerometer data (a_y in Figure 18), and ZACCL_OUT (see Table 15) contains z-axis accelerometer data (a_z in Figure 18). Table 16 illustrates the accelerometer data format with numerical examples.

Table 13. XACCL_OUT (Base Address = 0x0A), Read Only

Bits	Description
[15:0]	X-axis acceleration data, twos complement format, 1200 LSB/g, 0 g = 0x0000

Table 14. YACCL_OUT (Base Address = 0x0C), Read Only

Bits	Description
[15:0]	Y-axis acceleration data, twos complement format, 1200 LSB/g, 0 g = 0x0000

Table 15. ZACCL_OUT (Base Address = 0x0E), Read Only

Bits	Description
[15:0]	Z-axis acceleration data, twos complement format, 1200 LSB/g, 0 g = 0x0000

Table 16. Acceleration, Twos Complement Format

Acceleration (g)	Decimal	Hex	Binary
+18	+21,600	0x5460	0101 0100 0101 0000
+2 ÷ 1200	+2	0x0002	0000 0000 0000 0010
+1 ÷ 1200	+1	0x0001	0000 0000 0000 0001
0	0	0x0000	0000 0000 0000 0000
-1 ÷ 1200	-1	0xFFFF	1111 1111 1111 1111
-2 ÷ 1200	-2	0xFFFE	1111 1111 1111 1110
-18	-21,600	0xABAO	1010 1011 1010 0000

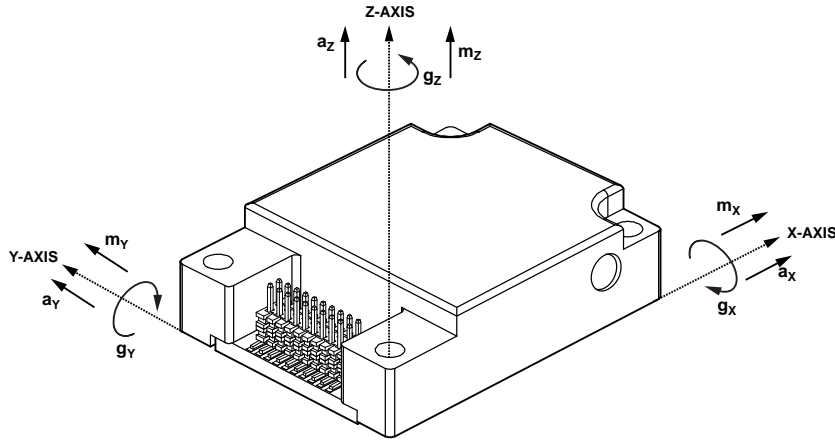

Figure 18. Inertial Sensor Direction Reference

MAGNETOMETERS

XMAGN_OUT (see Table 17) contains x-axis magnetometer data (m_x in Figure 18), YMAGN_OUT (see Table 18) contains y-axis magnetometer data (m_y in Figure 18), and ZMAGN_OUT (see Table 19) contains z-axis magnetometer data (m_z in Figure 18). Table 20 illustrates the magnetometer data format with numerical examples. The lower four bits of each magnetometer output data register (XMAGN_OUT[3:0]) are not active at the maximum update rate of 51.2 SPS. They become active when using SMPL_PRD[12:8] to average and decimate the data. The number of bits that become active is equal to the decimation setting number in SMPL_PRD[12:8]. For example, if SMPL_PRD[15:8] = 0x02, XMAGN_OUT[15:2] are active and XMAGN_OUT[1:0] are inactive.

Table 17. XMAGN_OUT (Base Address = 0x10), Read Only

Bits	Description
[15:0]	X-axis magnetic field intensity data, ± 1.9 gauss twos complement, 7 LSB/mgauss, 0x0000 = 0 mgauss

Table 18. YMAGN_OUT (Base Address = 0x12), Read Only

Bits	Description
[15:0]	Y-axis magnetic field intensity data, ± 1.9 gauss twos complement, 7 LSB/mgauss, 0x0000 = 0 mgauss

Table 19. ZMAGN_OUT (Base Address = 0x14), Read Only

Bits	Description
[15:0]	Z-axis magnetic field intensity data, ± 1.9 gauss twos complement, 7 LSB/mgauss, 0x0000 = 0 mgauss

Table 20. Magnetometer, Twos Complement Format

Magnetic Field (mgauss)	Decimal	Hex	Binary
+1900	+13,300	0x33F4	0011 0011 1111 0100
+2 \div 7	+2	0x0002	0000 0000 0000 0010
+1 \div 7	+1	0x0001	0000 0000 0000 0001
0	0	0x0000	0000 0000 0000 0000
+1 \div 7	-1	0xFFFF	1111 1111 1111 1111
+2 \div 7	-2	0xFFFE	1111 1111 1111 1110
-1900	-13,300	0xCC0C	1100 1100 0000 1100

BAROMETRIC PRESSURE

BARO_OUT (see Table 21) contains the barometric pressure data. Table 22 provides several numerical format examples for BARO_OUT.

Table 21. BARO_OUT (Base Address = 0x16), Read Only

Bits	Description
[15:0]	Barometric pressure data, binary data format, 20 μ bar per LSB, 0x0000 = 0 mbar

Table 22. Pressure, Binary, BARO_OUT

Pressure	Decimal	Hex	Binary
1200 mbar	60,000	0xEA60	1110 1010 0110 0000
1100 mbar	55,000	0xD6D8	1101 0110 1101 1000
1000 mbar	50,000	0xC350	1100 0011 0101 0000
0.04 mbar	2	0x0002	0000 0000 0000 0010
0.02 mbar	1	0x0001	0000 0000 0000 0001
0 mbar	0	0x0000	0000 0000 0000 0000

REMOTE PRESSURE SENSING

The ADIS16448 package offers a threaded hole (10-32) to support remote pressure sensing. Figure 19 provides an example of a fitting, which mates this hole to a barbed interface that enables a tight connection with rubber tubing (1/8”).

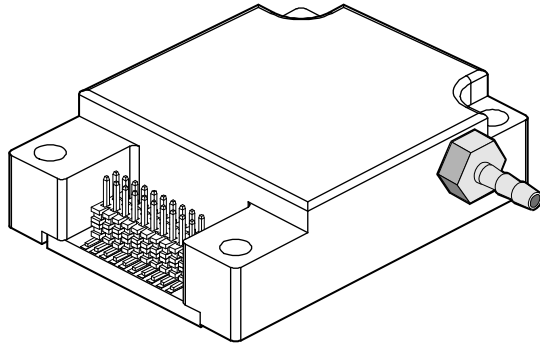

Figure 19. Barb Fitting for Remote Pressure Sensing

INTERNAL TEMPERATURE

The internal temperature measurement data loads into the TEMP_OUT (see Table 23) register. Table 24 illustrates the temperature data format. Note that this temperature represents an internal temperature reading, which does not precisely represent external conditions. The intended use of TEMP_OUT is to monitor relative changes in temperature.

Table 23. TEMP_OUT (Base Address = 0x18), Read Only

Bits	Description
[15:12]	Not used
[11:0]	Twos complement, 0.07386°C/LSB, 31°C = 0x000

Table 24. Temperature, Twos Complement Format

Temperature (°C)	Decimal	Hex	Binary
+105	+1002	3EA	0011 1110 1010
+85	+731	2DB	0010 1101 1011
+31.14772	+2	2	0000 0000 0010
+31.07386	+1	0	0000 0000 0001
+31	0	0	0000 0000 0000
+30.92614	-1	FFF	1111 1111 1111
+30.85228	-2	FFE	1111 1111 1110
-40	-962	C3E	1100 0011 1110

SYSTEM FUNCTIONS

GLOBAL COMMANDS

The GLOB_CMD register in Table 25 provides trigger bits for software reset, flash memory management, and calibration control. Start each of these functions by writing a 1 to the assigned bit in GLOB_CMD. After completing the task, the bit automatically returns to 0. For example, set GLOB_CMD[7] = 1 (DIN = 0xBE80) to initiate a software reset. Set GLOB_CMD[3] = 1 (DIN = 0xBE08) to back up the user register contents in nonvolatile flash. This sequence includes loading the control registers with the data in their respective flash memory locations prior to producing new data.

Table 25. GLOB_CMD (Base Address = 0x3E), Write Only

Bits	Description (Default = 0x0000)
[15:8]	Not used
7	Software reset
[6:4]	Not used
3	Flash update
2	Not used
1	Factory calibration restore
0	Gyroscope bias correction

PRODUCT IDENTIFICATION

The PROD_ID register in Table 28 contains the binary equivalent of 16,448. It provides a product specific variable for systems that need to track this in their system software. The LOT_ID1 and LOT_ID2 registers in Table 26 and Table 27 combine to provide a unique, 32-bit lot identification code. The SERIAL_NUM register in Table 29 contains a binary number that represents the serial number on the device label. The assigned serial numbers in SERIAL_NUM are lot specific.

Table 26. LOT_ID1 (Base Address = 0x52), Read Only

Bits	Description
[15:0]	Lot identification, binary code

Table 27. LOT_ID2 (Base Address = 0x54), Read Only

Bits	Description
[15:0]	Lot identification, binary code

Table 28. PROD_ID (Base Address = 0x56), Read Only

Bits	Description (Default = 0x4040)
[15:0]	Product identification = 0x4040

Table 29. SERIAL_NUM (Base Address = 0x58), Read Only

Bits	Description
[15:12]	Reserved
[11:0]	Serial number, 1 to 4094 (0xFFE)

SELF-TEST FUNCTION

The MSC_CTRL register in Table 30 provides a self-test function for the gyroscopes, accelerometers, magnetometers, and barometers. Note that the magnetometer results assume that the nonearth magnetic fields are low, in comparison to the magnetic field of the earth. This function allows the user to verify the mechanical integrity of each MEMS sensor. When enabled, the self test applies an electrostatic force to each internal sensor element, which causes them to move. The movement in each element simulates its response to actual rotation/acceleration and generates a predictable electrical response in the sensor outputs. Set MSC_CTRL[10] = 1 (DIN = 0xB504) to activate the internal self test routine, which compares the response to an expected range of responses and reports a pass/fail response to DIAG_STAT[5]. If this is high, review DIAG_STAT[15:10] to identify the failing sensor.

Table 30. MSC_CTRL (Base Address = 0x34), Read/Write

Bits	Description (Default = 0x0006)
[15:12]	Not used
11	Checksum memory test (cleared upon completion) ¹ 1 = enabled, 0 = disabled
10	Internal self test (cleared upon completion) ¹ 1 = enabled, 0 = disabled
[9:8]	Do not use, always set to 00
7	Not used
6	Point of percussion, see Figure 23 1 = enabled, 0 = disabled
5	Not used
4	CRC-16 code for burst mode 1 = include the CRC-16 code in burst read output sequence 0 = do not include the CRC-16 code in burst read output sequence
3	Not used
2	Data ready enable 1 = enabled, 0 = disabled
1	Data ready polarity 1 = active high when data is valid 0 = active low when data is valid
0	Data ready line select 1 = DIO2, 0 = DIO1

¹ The bit is automatically reset to 0 after finishing the test.

STATUS/ERROR FLAGS

The DIAG_STAT register in Table 31 provides error flags for a number of functions. Each flag uses 1 to indicate an error condition and 0 to indicate a normal condition. Reading this register provides access to the status of each flag and resets all of the bits to 0 for monitoring future operation. If the error condition remains, the error flag returns to 1 at the conclusion of the next sample cycle. The SPI communication error flag in DIAG_STAT[3] indicates that the number of SCLKs in a SPI sequence did not equal a multiple of 16 SCLKs.

Table 31. DIAG_STAT (Base Address = 0x3C), Read Only

Bits	Description (Default = 0x0000)
15	Z-axis accelerometer self-test failure 1 = fail, 0 = pass
14	Y-axis accelerometer self-test failure 1 = fail, 0 = pass
13	X-axis accelerometer self-test failure 1 = fail, 0 = pass
12	Z-axis gyroscope self-test failure 0 = pass
11	Y-axis gyroscope self-test failure 1 = fail, 0 = pass
10	X-axis gyroscope self-test failure 1 = fail, 0 = pass
9	Alarm 2 status 1 = active, 0 = inactive
8	Alarm 1 status 1 = active, 0 = inactive
7	New data, xMAGN_OUT/BARO_OUT
6	Flash test, checksum flag 1 = fail, 0 = pass
5	Self-test diagnostic error flag 1 = fail, 0 = pass
4	Sensor overrange 1 = overrange, 0 = normal
3	SPI communication failure 1 = fail, 0 = pass
2	Flash update failure 1 = fail, 0 = pass
1	Barometer functional test 1 = fail, 0 = pass
0	Magnetometer functional test 1 = fail, 0 = pass

Magnetometer/Barometer New Data Indicator

DIAG_STAT[7] indicates that all four registers have new, unread data in them. This bit rises to 1 after the xMAGN_OUT and BARO_OUT registers have new data updates. It lowers to zero after one of the registers are accessed using a SPI-driven read command. This bit does not return to zero after reading DIAG_STAT.

MEMORY MANAGEMENT

The FLASH_CNT register in Table 32 provides a 16-bit counter that helps track the number of write cycles to the nonvolatile flash memory. The flash updates every time a manual flash update occurs. A manual flash update is initiated by the GLOB_CMD[3] bit and is performed at the completion of the GLOB_CMD[1:0] functions (see Table 25).

Table 32. FLASH_CNT (Base Address = 0x00), Read Only

Bits	Description
[15:0]	Binary counter

Checksum Test

Set MSC_CTRL[11] = 1 (DIN = 0xB508) to perform a checksum test of the internal program memory. This function takes a summation of the internal program memory and compares it with the original summation value for the same locations (from factory configuration). If the sum matches the correct value, DIAG_STAT[6] is equal to 0. If it does not match, DIAG_STAT[6] is equal to 1. Make sure that the power supply is within specification for the entire 20 ms that this function takes to complete.

INPUT/OUTPUT CONFIGURATION

DATA READY INDICATOR

The data ready indicator provides a signal that indicates when the registers are updating, so that system processors can avoid data collision, a condition when internal register updates happen at the same time that an external processor requests it. The data ready signal has valid and invalid states. Using the transition from invalid to valid to trigger an interrupt service routine provides the most time for data acquisition (before the next register update). See Figure 4 and Table 2 for specific timing information. `MSC_CTRL[2:0]` (see Table 30) provide control bits for enabling this function, selecting the polarity of the valid state and I/O line assignment (DIO1, DIO2). The factory default setting of `MSC_CTRL[2:0] = 110` (DIN = 0xB406) establishes DIO1 as a data ready output line and assigns the valid state with a logic high (1). Set `MSC_CTRL[2:0] = 100` (DIN = 0xB404) to change the polarity of the data ready signal on DIO1 for interrupt inputs that require negative logic inputs for activation.

GENERAL-PURPOSE INPUT/OUTPUT

DIO1, DIO2, DIO3, and DIO4 are configurable, general-purpose input/output lines that serve multiple purposes. The data ready controls in `MSC_CTRL[2:0]` have the highest priority for configuring DIO1 and DIO2. The alarm indicator controls in `ALM_CTRL[2:0]` have the second highest priority for configuring DIO1 and DIO2. The external clock control associated with `SMPL_PRD[0]` has the highest priority for DIO4 configuration (see Table 34). `GPIO_CTRL` in Table 33 has the lowest priority for configuring DIO1, DIO2, and DIO4, and has absolute control over DIO3.

Table 33. GPIO_CTRL (Base Address = 0x32), Read/Write

Bits	Description (Default = 0x0000)
[15:12]	Not used
11	General-Purpose I/O Line 4 (DIO4) data level
10	General-Purpose I/O Line 3 (DIO3) data level
9	General-Purpose I/O Line 2 (DIO2) data level
8	General-Purpose I/O Line 1 (DIO1) data level
[7:4]	Not used
3	General-Purpose I/O Line 4 (DIO4) direction control 1 = output, 0 = input
2	General-Purpose I/O Line 3 (DIO3) direction control 1 = output, 0 = input
1	General-Purpose I/O Line 2 (DIO2) direction control 1 = output, 0 = input
0	General-Purpose I/O Line 1 (DIO1) direction control 1 = output, 0 = input

Example Input/Output Configuration

For example, set `GPIO_CTRL[3:0] = 0100` (DIN = 0xB204) to set DIO3 as an output signal pin and DIO1, DIO2, and DIO4 as input signal pins. Set the output on DIO3 to 1 by setting `GPIO_CTRL[10] = 1` (DIN = 0xB304). Then, read `GPIO_CTRL[7:0]` (DIN = 0x3200) and mask off `GPIO_CTRL[9:8]` and `GPIO_CTRL[11]` to monitor the digital signal levels on DIO4, DIO2, and DIO1.

DIGITAL PROCESSING CONFIGURATION

GYROSCOPES/ACCELEROMETERS

Figure 21 provides a diagram that describes all signal-processing components for the gyroscopes and accelerometers. The internal sampling system produces new data in the xGYRO_OUT and xACCL_OUT output data registers at a rate of 819.2 SPS. The SMPL_PRD register in Table 34 provides two functional controls that affect sampling and register update rates. SMPL_PRD[12:8] provides a control for reducing the update rate, using an averaging filter with a decimated output. These bits provide a binomial control that divides the data rate by a factor of 2 every time this number increases by 1. For example, set SMPL_PRD[15:8] = 0x04 (DIN = 0xB704) to set the decimation factor to 16. This reduces the update rate to 51.2 SPS and the bandwidth to ~25 Hz. The SMPL_PRD[12:8] setting affects the update rate for the TEMP_OUT register (see Table 23) as well.

Table 34. SMPL_PRD (Base Address = 0x36), Read/Write

Bits	Description (Default = 0x0001)
[15:13]	Not used
[12:8]	D, decimation rate setting, binomial, see Figure 21
[7:1]	Not used
0	Clock
1	internal sampling clock, 819.2 SPS
0	external sampling clock

INPUT CLOCK CONFIGURATION

SMPL_PRD[0] (see Table 34) provides a control for synchronizing the internal sampling to an external clock source. Set SMPL_PRD[0] = 0 (DIN = 0xB600) and GPIO_CTRL[3] = 0 (DIN = 0xB200) to enable the external clock. See Table 2 and Figure 4 for timing information.

Digital Filtering

The SENS_AVG register in Table 35 provides user controls for the low-pass filter. This filter contains two cascaded averaging filters that provide a Bartlett window, FIR filter response (see Figure 20). For example, set SENS_AVG[2:0] = 100 (DIN = 0xB804) to set each stage to 16 taps. When used with the default sample rate of 819.2 SPS and zero decimation (SMPL_PRD[15:8] = 0x00), this value reduces the sensor bandwidth to approximately 16 Hz.

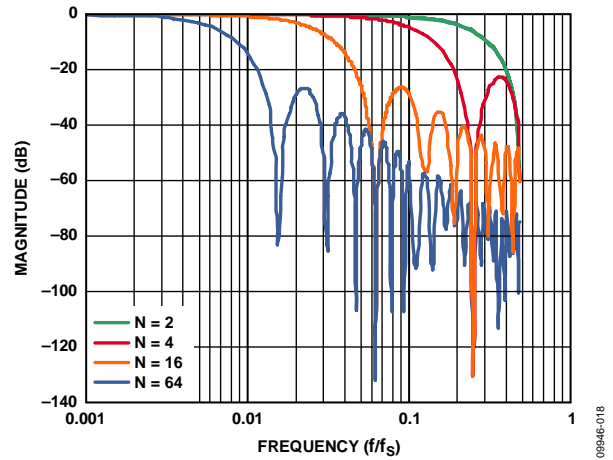

Figure 20. Bartlett Window, FIR Filter Frequency Response (Phase Delay = N Samples)

Dynamic Range

The SENS_AVG[10:8] bits provide three dynamic range settings for the gyroscopes. The lower dynamic range settings ($\pm 250^\circ/\text{sec}$ and $\pm 500^\circ/\text{sec}$) limit the minimum filter tap sizes to maintain resolution. For example, set SENS_AVG[10:8] = 010 (DIN = 0xB902) for a measurement range of $\pm 500^\circ/\text{sec}$. Because this setting can influence the filter settings, program SENS_AVG[10:8] before programming SENS_AVG[2:0] if more filtering is required.

Table 35. SENS_AVG (Base Address = 0x38), Read/Write

Bits	Description (Default = 0x0402)
[15:11]	Not used
[10:8]	Measurement range (sensitivity) selection 100 = $\pm 1000^\circ/\text{sec}$ (default condition) 010 = $\pm 500^\circ/\text{sec}$, filter taps ≥ 4 (Bits[2:0] $\geq 0x02$) 001 = $\pm 250^\circ/\text{sec}$, filter taps ≥ 16 (Bits[2:0] $\geq 0x04$)
[7:3]	Not used
[2:0]	Filter Size Variable B Number of taps in each stage; $N_B = 2^B$ See Figure 20 for filter response

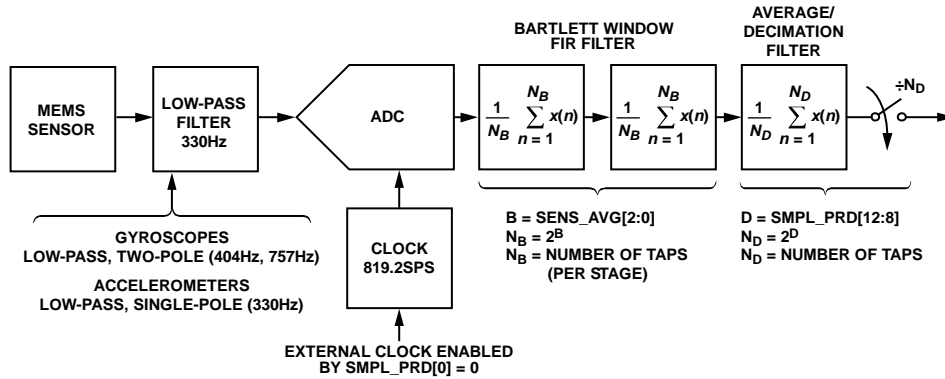

Figure 21. Sampling and Frequency Response Block Diagram

MAGNETOMETER/BAROMETER

The magnetometer (xMAGN_OUT) and barometer output registers (BARO_OUT) update at a rate of 51.2 SPS. When using the external clock, these registers update at a rate of 1/16th of the input clock frequency. The update rates for the magnetometer and barometers do not change with the SMPL_PRD [15:8] register settings, unless SMPL_PRD[15:8] > 0x04.

New Data Indicators

DIAG_STAT[7] (see Table 31) offers a new data bit for the magnetometer (xMAGN_OUT) and barometer output registers (BARO_OUT) registers. This bit rises to a 1, right after the xMAGN_OUT and BARO_OUT registers receive fresh data. It returns to 0 after one of the four registers experiences a read request.

The SEQ_CNT register (see Table 36) provides a counter function to help determine when there is new data in the magnetometer and barometer registers. When using the full sample rate (SMPL_PRD[15:8] = 0x00), SEQ_CNT starts at

a value of 16 and decrements every time the gyroscope data updates. When it reaches a value of 1, it returns to a value 16 after the next gyroscope update cycle. When SEQ_CNT equals 16, the magnetometer (xMAGN_OUT) and barometer (BARO_OUT) registers contain new data. The SEQ_CNT register can be useful during initialization to help synchronize read loops for new data in both magnetometer and barometer outputs. When beginning a continuous read loop, read SEQ_CNT to determine the number of sample cycles that must pass, before the magnetometer and barometer registers update.

Table 36. SEQ_CNT (Base Address = 0x3A), Read Only

Bits	Description
[15:11]	Don't care
[6:0]	Binary counter: 16 to 1, when D = 0 Counter range = 16/2 ^D - 1, when 1 ≤ D ≤ 4 See Table 34 for more information on D

CALIBRATION

The mechanical structure and assembly process of the ADIS16448 provide excellent position and alignment stability for each sensor, even after subjected to temperature cycles, shock, vibration, and other environmental conditions. The factory calibration includes a dynamic characterization of each gyroscope and accelerometer over temperature and generates sensor specific correction formulas.

GYROSCOPES

The XGYRO_OFF (see Table 37), YGYRO_OFF (see Table 38), and ZGYRO_OFF (see Table 39) registers provide user-programmable bias adjustment function for the X-, Y-, and Z-axis gyroscopes, respectively. Figure 22 illustrates that they contain bias correction factors that adjust to the sensor data immediately before it loads into the output register.

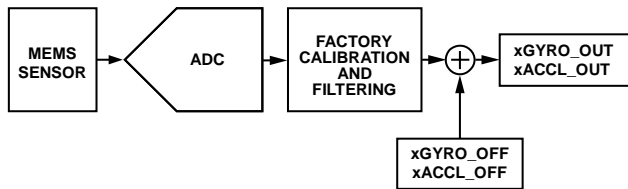

Figure 22. User Calibration, Gyroscopes, and Accelerometers

Gyroscope Bias Error Estimation

Any system level calibration function must start with an estimate of the bias errors, which typically comes from a sample of gyroscope output data, when the device is not in motion. The sample size of data depends on the accuracy goals. Figure 7 provides a trade-off relationship between averaging time and the expected accuracy of a bias measurement. Vibration, thermal gradients, and power supply instability can influence the accuracy of this process.

Table 37. XGYRO_OFF (Base Address = 0x1A), Read/Write

Bits	Description (Default = 0x0000)
[15:0]	X-axis, gyroscope offset correction factor, twos complement, 0.01°/sec/LSB, 0°/sec = 0x0000

Table 38. YGYRO_OFF (Base Address = 0x1C), Read/Write

Bits	Description (Default = 0x0000)
[15:0]	Y-axis, gyroscope offset correction factor, twos complement, 0.01°/sec/LSB, 0°/sec = 0x0000

Table 39. ZGYRO_OFF (Base Address = 0x1E), Read/Write

Bits	Description (Default = 0x0000)
[15:0]	Z-axis, gyroscope offset correction factor, twos complement, 0.01°/sec/LSB, 0°/sec = 0x0000

Gyroscope Bias Correction Factors

When the bias estimate is complete, multiply the estimate by -1 to change its polarity, convert it into digital format for the offset correction registers (see Table 37, Table 38, and Table 39), and write the correction factors to the correction registers. For example, lower the X-axis bias by 10 LSB (0.1°/sec) by setting XGYRO_OFF = 0xFFFF6 (DIN = 0x9BFF, 0x9AF6).

Single Command Bias Correction

GLOB_CMD[0] (see Table 25) loads the xGYRO_OFF registers with the values that are the opposite of the values that are in xGYRO_OUT, at the time of initiation. Use this command, together with the decimation filter (SMPL_PRD[12:8], see Table 34), to automatically average the gyroscope data and improve the accuracy of this function, as follows:

1. Set SENS_AVG[10:8] = 001 (DIN = 0xB901) to optimize the xGYRO_OUT sensitivity to 0.01°/sec/LSB.
2. Set SMPL_PRD[12:8] = 0x10 (DIN = 0xB710) to set the decimation rate to 65,536 (2¹⁶), which provides an averaging time of 80 seconds (65,536 ÷ 819.2 SPS).
3. Wait for 80 seconds while keeping the device motionless.
4. Set GLOB_CMD[0] = 1 (DIN = 0xBE01) and wait for the time it takes to perform the flash memory backup.

ACCELEROMETERS

The XACCL_OFF (see Table 40), YACCL_OFF (see Table 41), and ZACCL_OFF (see Table 42) registers provide user programmable bias adjustment function for the X-, Y-, and Z-axis accelerometers, respectively. These registers adjust the accelerometer data in the same manner as XGYRO_OFF in Figure 22.

Table 40. XACCL_OFF (Base Address = 0x20), Read/Write

Bits	Description (Default = 0x0000)
[15:0]	X-axis, accelerometer offset correction factor, twos complement, 1/1200 g/LSB, 0 g = 0x0000

Table 41. YACCL_OFF (Base Address = 0x22), Read/Write

Bits	Description (Default = 0x0000)
[15:14]	Not used
[13:0]	Y-axis, accelerometer offset correction factor, twos complement, 1/1200 g/LSB, 0 g = 0x0000

Table 42. ZACCL_OFF (Base Address = 0x24), Read/Write

Bits	Description (Default = 0x0000)
[15:14]	Not used
[13:0]	Z-axis, accelerometer offset correction factor, twos complement, 1/1200 g/LSB, 0 g = 0x0000

Accelerometer Bias Error Estimation

Under static conditions, orient each accelerometer in positions where the response to gravity is predictable. A common approach to this is to measure the response of each accelerometer when they are oriented in peak response positions, that is, where ±1 g is the ideal measurement position. Next, average the +1 g and -1 g accelerometer measurements together to estimate the residual bias error. Using more points in the rotation can improve the accuracy of the response.

Accelerometer Bias Correction Factors

When the bias estimate is complete, multiply the estimate by -1 to change its polarity, convert it to the digital format for the offset correction registers (see Table 40, Table 41 or Table 42) and write the correction factors to the correction registers. For example, lower the x-axis bias by 12 LSB (10 mg) by setting XACCL_OFF = 0xFFFF4 (DIN = 0xA1FF, 0xA0F4).

Point of Percussion Alignment

Set MSC_CTRL[6] = 1 (DIN = 0xB446) to enable this feature and maintain the factory default settings for DIO1. This feature performs a point of percussion translation to the point identified in Figure 23. See Table 30 for more information on MSC_CTRL.

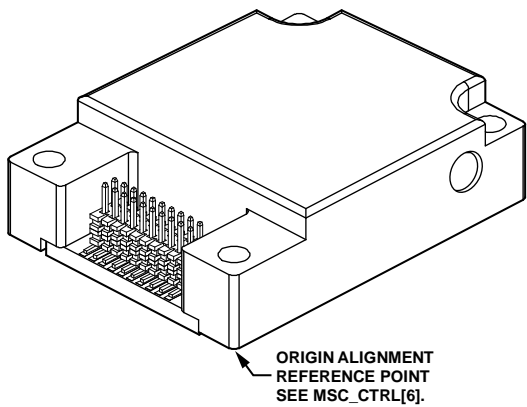

Figure 23. Point of Percussion Physical Reference

MAGNETOMETER CALIBRATION

The ADIS16448 provides registers that contribute to both hard iron and soft iron correction factors, as shown in Figure 24.

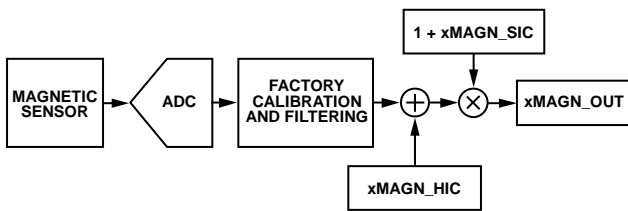

Figure 24. Hard Iron and Soft Iron Factor Correction

Hard Iron Correction

The XMAGN_HIC (see Table 43), YMAGN_HIC (see Table 44), and ZMAGN_HIC (see Table 45) registers provide the user programmable bias adjustment function for the X-, Y-, and Z-axis magnetometers, respectively. Hard iron effects result in an offset of the magnetometer response.

Table 43. XMAGN_HIC (Base Address = 0x26), Read/Write

Bits	Description (Default = 0x0000)
[15:0]	X-axis hard iron correction factor, twos complement, 7 LSB/mgauss, 0x0000 = 0

Table 44. YMAGN_HIC (Base Address = 0x28), Read/Write

Bits	Description (Default = 0x0000)
[15:0]	Y-axis hard iron correction factor, twos complement, 7 LSB/mgauss, 0x0000 = 0

Table 45. ZMAGN_HIC (Base Address = 0x2A), Read/Write

Bits	Description (Default = 0x0000)
[15:0]	Z-axis hard iron correction factor, twos complement, 7 LSB/mgauss, 0x0000 = 0 mgauss

Hard Iron Factors

When the hard iron error estimation is complete, take the following steps:

1. Multiply the estimate by -1 to change its polarity.
2. Convert it into digital format for the hard iron correction registers (see Table 43).
3. Write the correction factors to the registers. For example, lower the x-axis bias by 10 LSB (~ 1.429 mgauss) by setting XMAGN_HIC = 0xFFFF6 (DIN = 0xA7FF, 0xA6F6)

Soft Iron Effects

The XMAGN_SIC (see Table 46), YMAGN_SIC (see Table 47), and ZMAGN_SIC (see Table 48) registers provide an adjustment variable for the magnetometer sensitivity adjustment in each magnetometer response to simplify the process of performing a system level soft iron correction.

Table 46. XMAGN_SIC (Base Address = 0x2C), Read/Write

Bits	Description (Default = 0x8000)
[15:0]	X-axis soft iron correction factor, twos complement format, 1 LSB = 100%/32,767 0x7FFF = 100% increase (2x), 0x8000 = 100% decrease (0x)

Table 47. YMAGN_SIC (Base Address = 0x2E), Read/Write

Bits	Description (Default = 0x8000)
[15:0]	Y-axis soft iron correction factor, twos complement format, 1 LSB = 100%/32,767 0x7FFF = 100% increase (2x), 0x8000 = 100% decrease (0x)

Table 48. ZMAGN_SIC (Base Address = 0x30), Read/Write

Bits	Description (Default = 0x8000)
[15:0]	Z-axis soft iron correction factor, twos complement format, 1 LSB = 100%/32,767 0x7FFF = 100% increase (2x), 0x8000 = 100% decrease (0x)

FLASH UPDATES

When using the user calibration registers to optimize system level accuracy, set GLOB_CMD[3] = 1 (DIN = 0xBE04) to save these settings in nonvolatile flash memory. Be sure to consider the endurance rating of the flash memory when determining how often to update the user correction factors in the flash memory.

RESTORING FACTORY CALIBRATION

Set GLOB_CMD[1] = 1 (DIN = 0xBE02) to execute the factory calibration restore function, which resets the gyroscope and accelerometer offset registers to 0x0000 and all sensor data to 0. Then, it automatically updates the flash memory and restarts sampling and processing data. See Table 25 for information on GLOB_CMD.

ALARMS

Alarm 1 and Alarm 2 provide two independent alarms with programmable levels, polarity, and data sources.

STATIC ALARM USE

The static alarms setting compares the data source selection (ALM_CTRL[15:8]) with the values in the ALM_MAGx registers listed in Table 49 and Table 50, using ALM_MAGx[15] to determine the trigger polarity. The data format in these registers matches the format of the data selection in ALM_CTRL[15:8]. See Table 54, Alarm 1, for a static alarm configuration example.

Table 49. ALM_MAG1 (Base Address = 0x40), Read/Write

Bits	Description (Default = 0x0000)
[15:0]	Threshold setting; matches for format of ALM_CTRL[11:8] output register selection

Table 50. ALM_MAG2 (Base Address = 0x42), Read/Write

Bits	Description (Default = 0x0000)
[15:0]	Threshold setting; matches for format of ALM_CTRL[15:12] output register selection

DYNAMIC ALARM USE

The dynamic alarm setting monitors the data selection for a rate-of-change comparison. The rate-of-change comparison is represented by the magnitude in the ALM_MAGx registers over the time represented by the number-of-samples setting in the ALM_SMPLx registers, located in Table 51 and Table 52. See Table 54, Alarm 2, for a dynamic alarm configuration example.

Table 51. ALM_SMPL1 (Base Address = 0x44), Read/Write

Bits	Description (Default = 0x0000)
[15:8]	Not used
[7:0]	Binary, number of samples (both 0x00 and 0x01 = 1)

Table 52. ALM_SMPL2 (Base Address = 0x46), Read/Write

Bits	Description (Default = 0x0000)
[15:8]	Not used
[7:0]	Binary, number of samples (both 0x00 and 0x01 = 1)

ALARM REPORTING

The DIAG_STAT[9:8] bits provide error flags that indicate an alarm condition. The ALM_CTRL[2:0] bits provide controls for a hardware indicator using DIO1 or DIO2.

Table 53. ALM_CTRL (Base Address = 0x48), Read/Write

Bits	Description (Default = 0x0000)
[15:12]	Alarm 2 data source selection 0000 = disable 0001 = XGYRO_OUT 0010 = YGYRO_OUT 0011 = ZGYRO_OUT 0100 = XACCL_OUT 0101 = YACCL_OUT 0110 = ZACCL_OUT 0111 = XMAGN_OUT 1001 = YMAGN_OUT 1010 = ZMAGN_OUT 1011 = BARO_OUT 1100 = TEMP_OUT
[11:8]	Alarm 1 data source selection (same as Alarm 2)
7	Alarm 2, dynamic/static (1 = dynamic, 0 = static)
6	Alarm 1, dynamic/static (1 = dynamic, 0 = static)
5	Alarm 2, polarity (1 = greater than ALM_MAG2)
4	Alarm 1, polarity (1 = greater than ALM_MAG1)
3	Data source filtering (1 = filtered, 0 = unfiltered)
2	Alarm indicator (1 = enabled, 0 = disabled)
1	Alarm indicator active polarity (1 = high, 0 = low)
0	Alarm output line select (1 = DIO2, 0 = DIO1)

Alarm Example

Table 54 offers an example that configures Alarm 1 to trigger when filtered ZACCL_OUT data drops below 0.7 g and Alarm 2 to trigger when filtered ZGYRO_OUT data changes by more than 50°/sec over a 100 ms period, or 500°/sec². The filter setting helps reduce false triggers from noise and refines the accuracy of the trigger points. The ALM_SMPL2 setting of 82 samples provides a comparison period that is approximately equal to 100 ms for an internal sample rate of 819.2 SPS.

Table 54. Alarm Configuration Example

DIN	Description
0xC936, 0xC8AF	ALM_CTRL = 0x36AF Alarm 2: dynamic, Δ-ZGYRO_OUT (Δ-time, ALM_SMPL2) > ALM_MAG2 Alarm 1: static, ZACCL_OUT < ALM_MAG1, filtered data DIO2 output indicator, positive polarity
0xC313, 0xC288	ALM_MAG2 = 0x04E2 = 1,250 LSB = 50°/sec
0xC10A, 0xC0F0	ALM_MAG1 = 0x0348 = 840 LSB = +0.7 g
0xC652	ALM_SMPL2[7:0] = 0x52 = 82 samples 82 samples ÷ 819.2 SPS = ~100 ms

APPLICATIONS INFORMATION

MOUNTING TIPS

The mounting and installation process can influence gyroscope bias repeatability and other key parametric behaviors. To preserve the best performance, use the following guidelines when developing an attachment approach for the [ADIS16448](#):

- Focus mounting force at the machine screw locations.
- Avoid direct force application on the substrate.
- Avoid placing mounting pressure on the package lid, except for the edges that border the exposed side of the substrate.
- Use a consistent mounting torque of 28 inch-ounces on mounting hardware.
- Avoid placing translational forces on the electrical connector.

For additional mounting ideas and tips, refer to the [AN-1305 Application Note](#).

POWER SUPPLY CONSIDERATIONS

The power supply must be within 3.15 V and 3.45 V for normal operation and optimal performance. During start up, the internal power conversion system starts drawing current when VDD reaches 1.6 V. The internal processor begins initializing when VDD is equal to 2.35 V. After the processor starts, VDD must reach 2.7 V within 128 ms. Also, make sure that the power supply drops below 1.6 V to shut the device down. Figure 9 shows a 10 μ F capacitor on the power supply. Using this capacitor supports optimal noise performance in the sensors.

ADIS16IMU2/PCBZ

The [ADIS1644X/FLEX](#) and [ADIS16IMU2/PCBZ](#) accessories provide a simplified method for connecting to an embedded processor platform or to the [EVAL-ADIS2](#) evaluation system. Figure 26 provides a mechanical design example for using these

two components with the [ADIS16448](#) inertial measurement unit (IMU) in a system.

Figure 25 provides the pin assignments for J1 on the [ADIS16IMU2/PCBZ](#) breakout board.

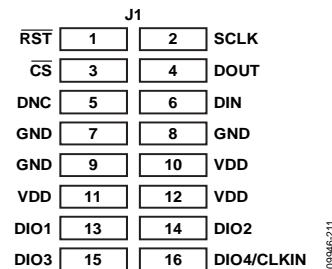

Figure 25. J1 Pin Assignments for the [ADIS16IMU2/PCBZ](#)

The C1 and C2 locations on the [ADIS16IMU2/PCBZ](#) provide users with the pads to install 10 μ F of capacitance across VDD and GND, which Figure 9 recommends for best performance.

PC-BASED EVALUATION TOOLS

The [EVAL-ADIS2](#) supports PC-based evaluation of the [ADIS16448](#). Refer to the [EVAL-ADIS2 Evaluation System Wiki Guide](#) for more information on connecting the [ADIS16448](#) to the [EVAL-ADIS2](#) system.

X-RAY SENSITIVITY

Exposure to high dose rate X-rays, such as those in production systems that inspect solder joints in electronic assemblies, may affect accelerometer bias errors. For optimal performance, avoid exposing the [ADIS16448](#) to this type of inspection.

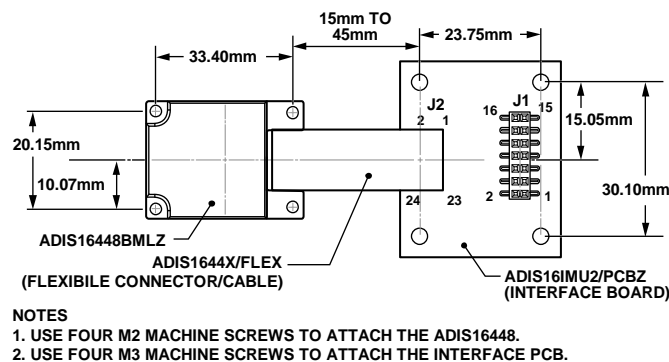

Figure 26. Physical Diagram for [ADIS16448](#) Accessories

OUTLINE DIMENSIONS

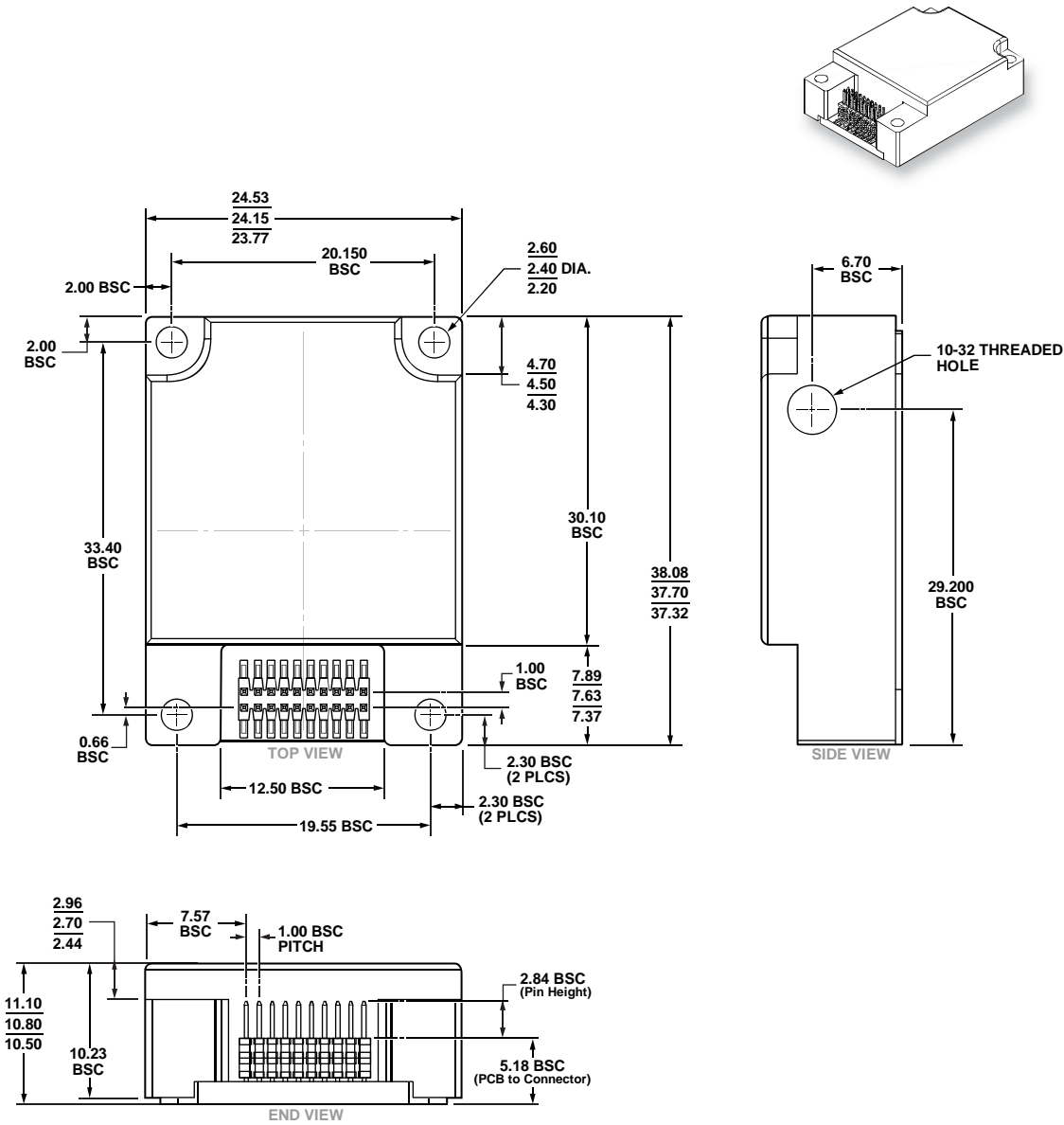

Figure 27. 20-Lead Module with Connector Interface (ML-20-2)
Dimensions shown in millimeters

ORDERING GUIDE

Model ^{1, 2}	Temperature Range	Package Description	Package Option
ADIS16448BMLZ	-40°C to +105°C	20-Lead Module with Connector Interface	ML-20-2
ADIS16448BMLZ-P	-40°C to +105°C	20-Lead Module with Connector Interface	ML-20-2

¹ Z = RoHS Compliant Part.

² The ADIS16448BMLZ-P includes Parylene-C coating on the internal substrate and components, which has a thickness of 0.001" (±20%), along with a connector that has gold plating that is at least 0.00003 inches thick.

Looking for pricing, stock, or lifecycle information?

Click below to explore more details on WIN SOURCE:

 [View ADIS16448BMLZ on WIN SOURCE](#)

 [Analog Devices Inc. Information](#)

Optimize Your Supply Chain with WIN SOURCE Solutions

-  Global Sourcing Solution
-  Obsolete Management
-  Cost Control Management
-  Shortage Management
-  Alternative Solution
-  Excess Inventory Management