



**THE DATASHEET OF
AP39811AS7-13**



Description

The AP39811 is a high performance power switcher integrated with a primary side regulation controller and an integrated N-channel power MOSFET for the application of shaver charger. It is easy to achieve a targeted slant IV curve without an opto-coupler and secondary control circuitry. A resistor connected between FB pin and CPR pin is introduced to adjust the slew rate of the slant IV curve.

The AP39811 operates in Pulse Frequency Modulation (PFM) mode and peak current Amplitude Modulation (AM) mode to form a fine tune frequency curve within the whole power range. Therefore, AP39811 can achieve high average efficiency and avoid audible noise.

The AP39811 provides comprehensive protections without additional circuitry. It contains V_{CC} over voltage protection, output over voltage protection, XFMR anti-saturation protection, bulk-cap open protection, open loop protection, over temperature protection, etc.

The AP39811 is available in SO-7 package.

Features

- Primary Side Control for Eliminating Opto-Coupler
- Built-In 650V Power MOSFET
- Slant IV Curve Control
- 75mW No-Load Input Power
- Flyback Topology in DCM Operation
- External Adjustable Line Compensation for CC
- Multiple AM/PFM Control Mode to Improve Audio Noise and Efficiency
- Frequency Jitter to Improve System EMI
- Valley-On for the Higher Efficiency and Better EMI Behavior
- Multiple Protections:
 - Over Voltage Protection (OVP)
 - Bulk-Cap Open Protection
 - Transformer Saturation Protection (TSP) via Primary Peak Current Limitation
 - Internal Over Temperature Protection (OTP)
- SO-7 Package
- **Totally Lead-Free & Fully RoHS Compliant (Notes 1 & 2)**
- **Halogen and Antimony Free. "Green" Device (Note 3)**

Notes: 1. No purposely added lead. Fully EU Directive 2002/95/EC (RoHS), 2011/65/EU (RoHS 2) & 2015/863/EU (RoHS 3) compliant.
 2. See <https://www.diodes.com/quality/lead-free/> for more information about Diodes Incorporated's definitions of Halogen- and Antimony-free, "Green" and Lead-free.
 3. Halogen- and Antimony-free "Green" products are defined as those which contain <900ppm bromine, <900ppm chlorine (<1500ppm total Br + Cl) and <1000ppm antimony compounds.

Pin Assignments

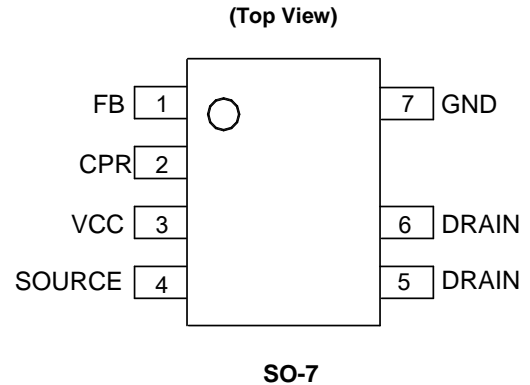

Applications

- Shaver Charger

Typical Applications Circuit

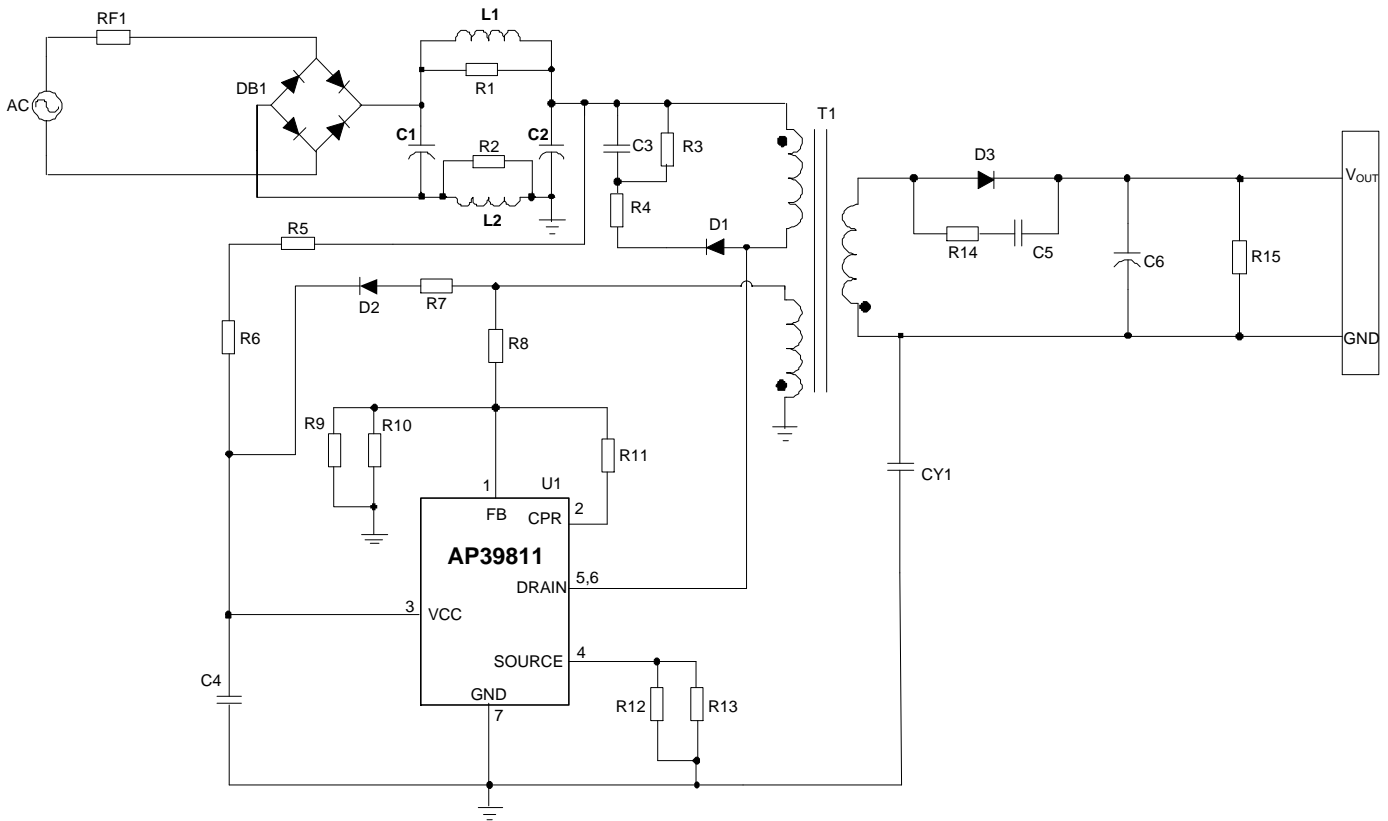

Pin Descriptions

Pin Number	Pin Name	Function
1	FB	Connect to the auxiliary winding through a resistor divider network, used as a multi-function pin to realize output voltage detection for CV control, t_{ONS} detection for CC control, line voltage sense for line compensation, and cable compensation as well.
2	CPR	A resistor is connected between FB pin and CPR pin to adjust slant-IV curve.
3	VCC	The power supply for the IC.
4	SOURCE	SOURCE terminal of the integrated MOSFET. The primary side current is sensed through this pin.
5, 6	DRAIN	DRAIN terminal of the integrated MOSFET.
7	GND	Signal ground. Current return for driver and control circuits.

NEW PRODUCT

Functional Block Diagram

NEW PRODUCT

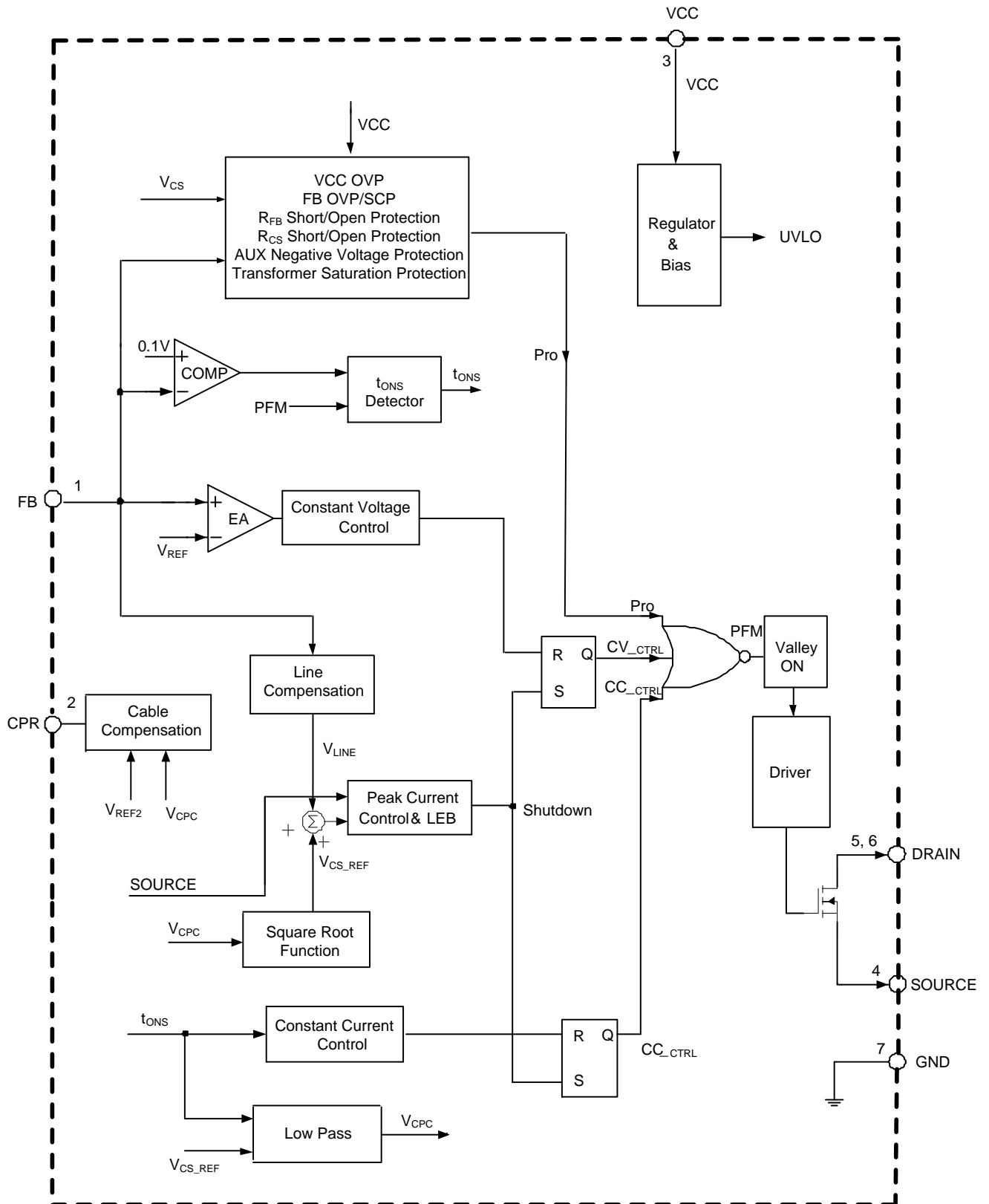

Absolute Maximum Ratings (Note 4)

Symbol	Parameter	Rating	Unit
V_{CC}	Supply Voltage	-0.3 to 35	V
V_{SOURCE}	SOURCE Input Voltage	-0.3 to 8	V
V_{CPR}	CPR Input Voltage	-0.3 to 8	V
V_{FB}	FB Input Voltage	-0.3 to 8	V
V_{DS}	Drain-Source Voltage ($T_J=+25^{\circ}C$)	650	V
T_J	Operating Junction Temperature	-40 to +150	$^{\circ}C$
T_{STG}	Storage Temperature	-65 to +150	$^{\circ}C$
T_{LEAD}	Lead Temperature (Soldering, 10s)	+300	$^{\circ}C$
θ_{JC}	Thermal Resistance (Junction to Case) (Note 5)	2	$^{\circ}C/W$
θ_{JA}	Thermal Resistance (Junction to Ambient) (Note 5)	78	$^{\circ}C/W$
—	ESD (Human Body Model)	2000	V
—	ESD (Charged Device Model)	1000	V

- Notes: 4. Stresses greater than those listed under *Absolute Maximum Ratings* can cause permanent damage to the device. These are stress ratings only, and functional operation of the device at these or any other conditions beyond those indicated under *Recommended Operating Conditions* is not implied. Exposure to *Absolute Maximum Ratings* for extended periods can affect device reliability.
5. Test condition: Device mounted on FR-4 substrate PC board, 2oz copper, with 1inch² cooling area.

Recommended Operating Conditions

Symbol	Parameter	Min	Max	Unit
V_{CC}	Supply Voltage	10	28	V
T_A	Ambient Temperature	-40	+85	$^{\circ}C$

Electrical Characteristics (@ $T_A = +25^\circ\text{C}$, $V_{CC} = 15\text{V}$, unless otherwise specified.)

Symbol	Parameter	Condition	Min	Typ	Max	Unit
STARTUP AND UVLO SECTION						
V_{TH_ST}	Startup Threshold	—	14.5	16	17.5	V
$V_{OPR(MIN)}$	Minimum Operating Voltage	—	6.1	6.8	7.5	V
STANDBY CURRENT SECTION						
I_{ST}	Startup Current	$V_{CC} = V_{TH_ST} - 1\text{V}$ Before Startup	—	1	3	μA
I_{CC_OPR}	Minimum Operating Current	Static Current	450	550	650	μA
CURRENT SENSE SECTION						
V_{CS_H}	Peak Current Sense Threshold Voltage	33% to 100% CC Load	540	600	660	mV
V_{CS_L}		No Load to 3% CC Load	180	200	220	mV
R_{LINE}	Built-In Line Compensation Resistance	—	48	60	72	Ω
t_{LEB}	Leading Edge Blanking	—	250	300	350	ns
CONSTANT VOLTAGE SECTION						
V_{FB}	Feedback Threshold Voltage	Closed Loop Test of V_{OUT}	2.3	2.35	2.4	V
Ratio $SAMPLE_L$	Sample Ratio	No Load to 3% CC Load	50	55	60	%
Ratio $SAMPLE_H$	Sample Ratio	33% to 100% CC Load	55	60	65	%
t_{SAMPLE_H}	Sample Time When $t_{ONS} > 15\mu\text{s}$	—	6.4	8	9.6	μs
CONSTANT CURRENT SECTION						
t_{ONS}/t_{SW}	Secondary Winding Conduction Duty	Tested @ $V_{FB} = 1\text{V}$	0.7	0.75	0.8	—
FREQUENCY JITTER						
$\Delta V_{CS}/V_{CS}$	V_{CS} Modulation	No Load to Full Load	2.5	3	3.5	%
CABLE COMPENSATION						
$V_{CPR_CABLE_MIN}$	Minimum Cable Compensation	AP39811A	1.33	1.4	1.47	V
		AP39811B	2.04	2.14	2.24	V
VALLEY-ON SECTION						
t_{VAL-ON}	Valid Off Time of Valley-On	From the End of t_{ONS}	26	32	38	μs
DYNAMIC SECTION						
$t_{OFF(MAX)}$	Maximum Off Time	AP39811A	0.9	1	1.1	ms
		AP39811B	700	768	836	μs
PROTECTION FUNCTION SECTION						
$V_{FB(OVP)}$	Over Voltage Protection at FB Pin	—	3.3	3.6	3.9	V
$V_{CC(OVP)}$	Over Voltage Protection at VCC Pin	—	29.5	32	34.5	V
$t_{ONP(MAX)}$	Maximum Turn-On Time	—	12.8	16	19.2	μs
$V_{CS(MIN)}$	Minimum Peak Current Sense Voltage at $t_{ONP} = 4\mu\text{s}$ (First Cycle)	—	80	100	130	mV
$V_{CS(MAX)}$	Maximum CS Voltage	—	675	750	825	mV
$V_{FB_NEG_L}$	Low Threshold for FB Negative Voltage Protection	—	8.4	14	19.6	mV
$V_{FB_NEG_H}$	High Threshold for FB Negative Voltage Protection	—	25.2	42	58.8	mV

Electrical Characteristics (continued) (@ $T_A = +25^\circ\text{C}$, $V_{CC} = 15\text{V}$, unless otherwise specified.)

Symbol	Parameter	Condition	Min	Typ.	Max	Unit
T_{OTP}	Shutdown Temperature	—	+115	+130	+145	$^\circ\text{C}$
T_{HYS}	Temperature Hysteresis	—	+27	+30	+33	$^\circ\text{C}$
Power MOSFET Section						
BV_{DSS}	Integrated MOSFET Drain-Source Break-Down Voltage (Note 6)	—	650	—	—	V
$R_{DS(ON)}$	Static Drain-Source On-Resistance	—	—	9	—	Ω
I_D	Continuous Drain Current	—	—	—	1	A

Note: 6. The aging condition of drain-source voltage is 80% of BV_{DSS} .

Performance Characteristics

Start-Up Voltage vs. Ambient Temperature

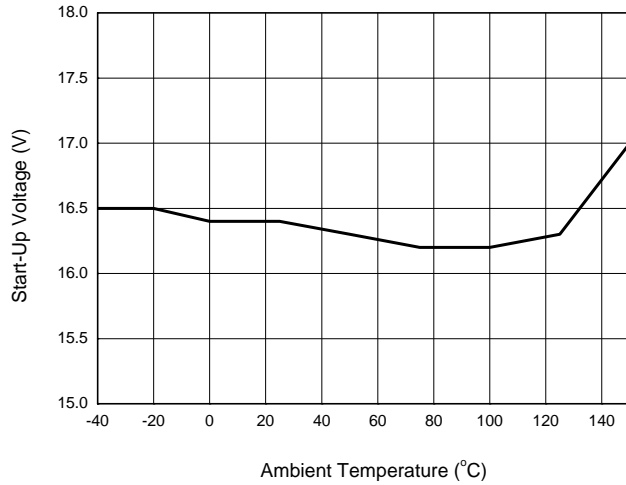

Start-Up Current vs. Ambient Temperature

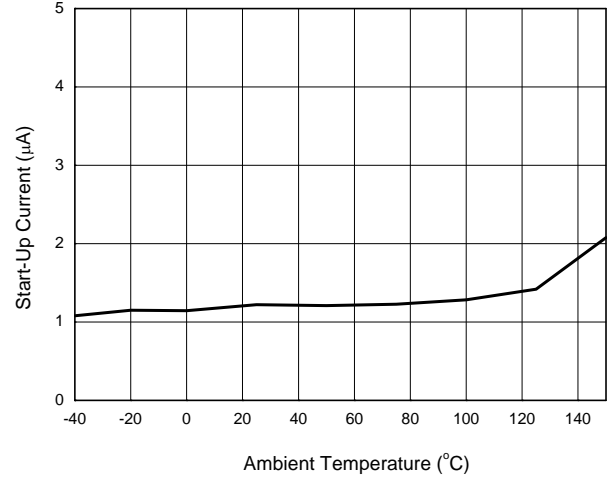

Minimal Operating Voltage vs. Ambient Temperature

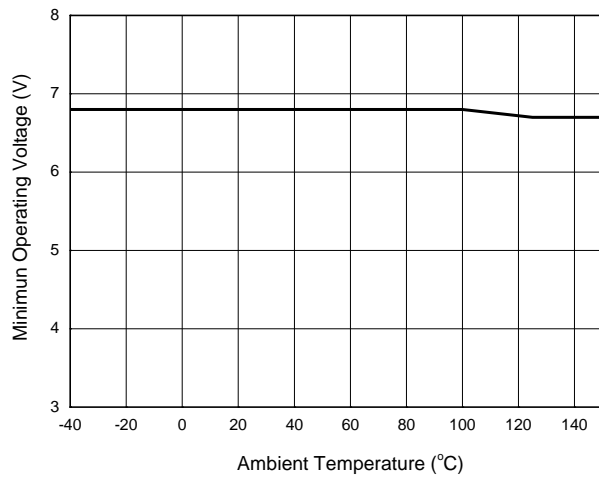

Operating Current vs. Ambient Temperature

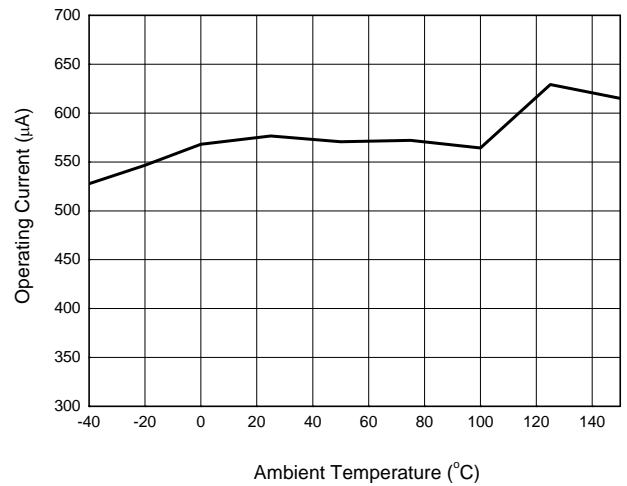

V_{CS_H} vs. Ambient Temperature

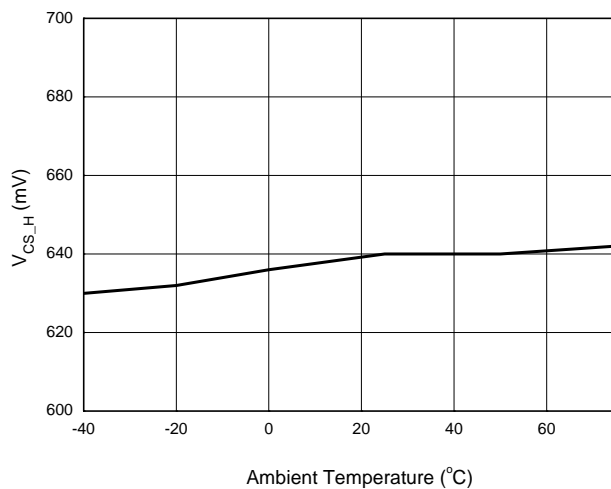

Minimum Cable Compensation Voltage vs. Ambient Temperature

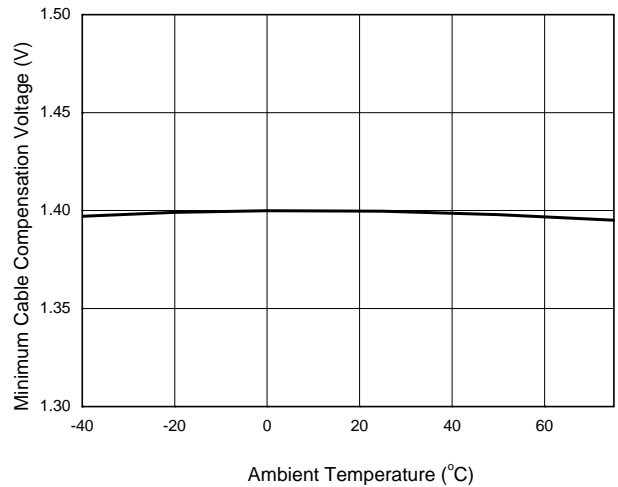

Performance Characteristics (continued)

Feedback Voltage vs. Ambient Temperature

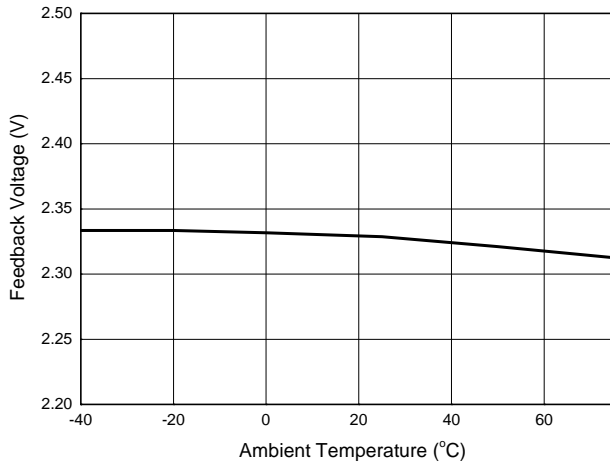

V_{CC} OVP Voltage vs. Ambient Temperature

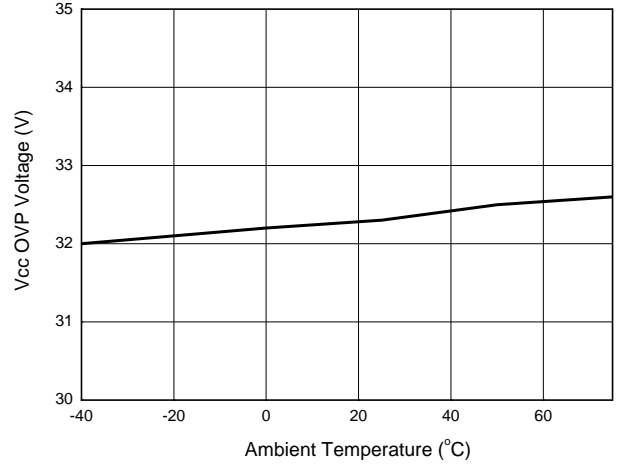

Line Compensation Resistance vs. Ambient Temperature

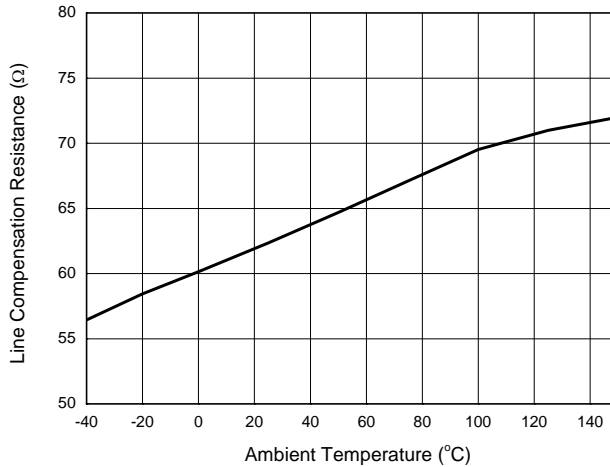

(AP39811A) Maximum Off Time vs. Ambient Temperature

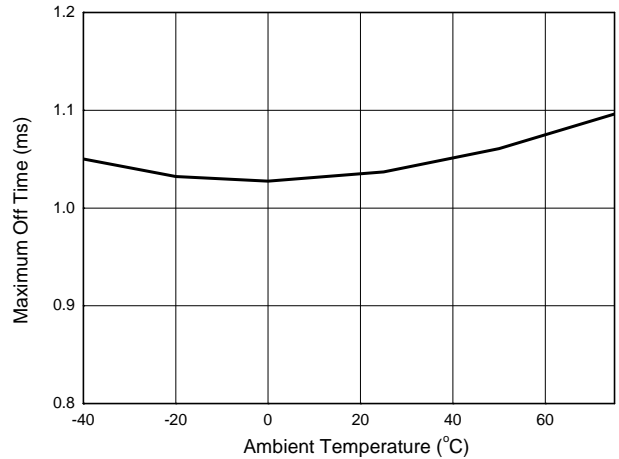

Low Threshold Voltage for FB Negative Protection vs. Ambient Temperature

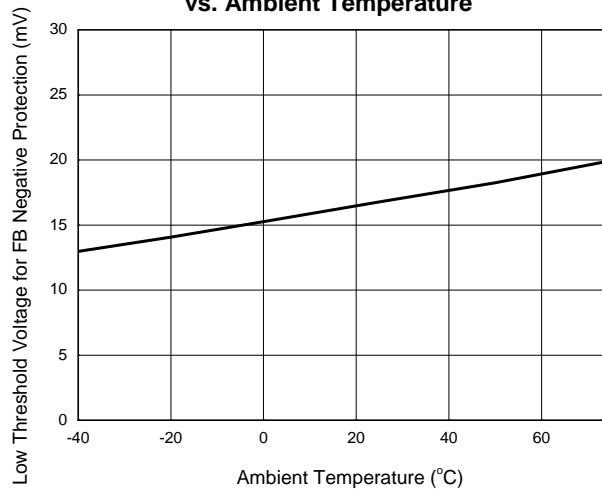

Operation Description

1. The Conventional PSR Operating Waveforms

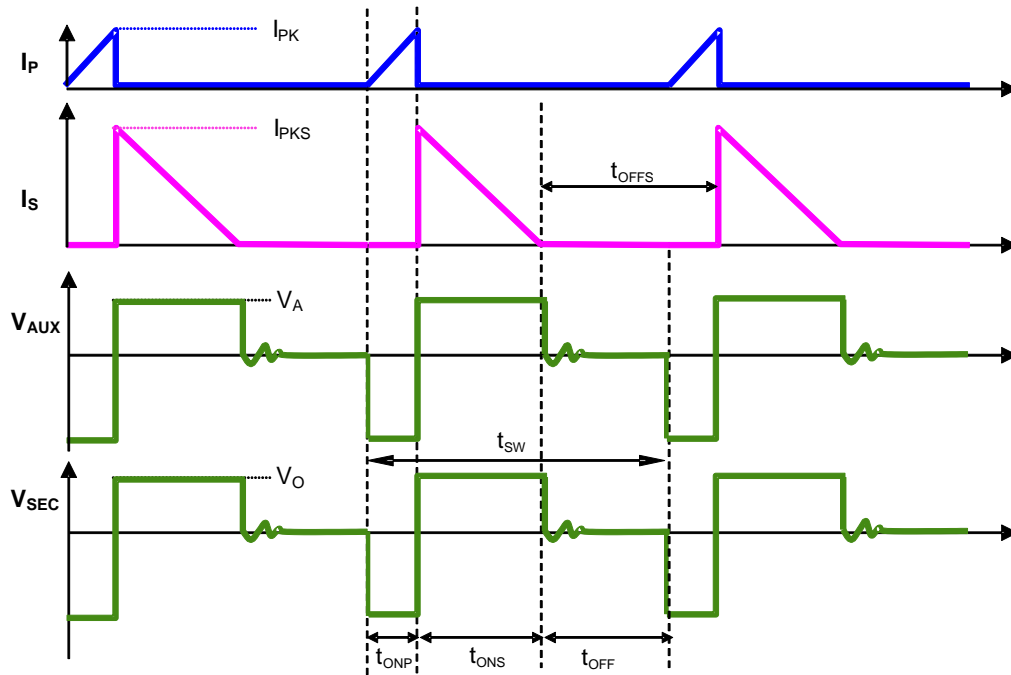

Figure 1. The Operation Waveform of Flyback PSR System

Figure 1 shows the typical waveforms which demonstrate the basic operating principle of AP39811 application. And the parameters are defined as following.

I_P ---The primary-side current

I_S ---The secondary-side current

I_{PK} ---Peak value of primary-side current

I_{PKS} ---Peak value of secondary-side current

V_{SEC} ---The transient voltage at secondary winding

V_O ---The output voltage

V_{AUX} ---The transient voltage at auxiliary winding

V_A --- The stable voltage at auxiliary winding when rectification diode is in conducting status, which equals the sum of voltage VCC and the forward voltage drop of auxiliary diode

t_{SW} ---The period of switching frequency

t_{ONP} ---The conduction time when primary-side switch is "ON"

t_{ONS} ---The conduction time when secondary-side diode is "ON"

t_{OFF} ---The dead time when neither primary-side switch nor secondary side diode is "ON"

t_{OFFS} --- The time when secondary-side diode is "OFF"

For primary-side regulation, the primary current $i_p(t)$ is sensed by a current sense resistor R_{CS} connected to pin SOURCE. The current rises up linearly at a rate of:

$$\frac{di_p(t)}{dt} = \frac{V_{IN}(t)}{L_M} \quad (1)$$

As illustrated in Figure 1, when the current $i_p(t)$ rises up to I_{PK} , the primary MOSFET would turn off. The constant peak current is given by:

$$I_{PK} = \frac{V_{CS}}{R_{CS}} \quad (2)$$

Operation Description (continued)

The energy stored in the magnetizing inductance L_M each cycle is therefore:

$$E_g = \frac{1}{2} \times L_M \cdot I_{PK}^2 \quad (3)$$

So the power transferring from the input to the output is given by:

$$P = \frac{1}{2} \times L_M \times I_{PK}^2 \times f_{SW} \quad (4)$$

Where, the f_{SW} is the switching frequency. When the peak current I_{PK} is constant, the output power would depend on the switching frequency f_{SW} .

2. A Special IV Curve for Shaver Charger

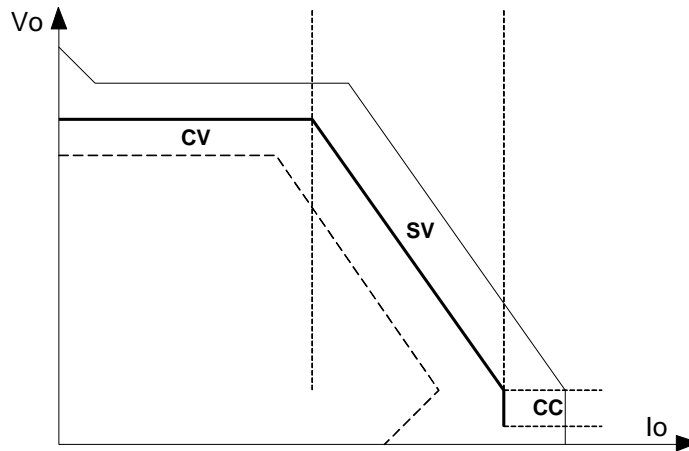

Figure 2. A Special IV Curve

Figure 2 is a typical IV curve special for shaver charger, comparing to a conventional charger. In addition to usual Constant Voltage (CV) part and Constant Current (CC) part, shaver charger requires a unique Slanted Voltage (SV) part. To achieve this special IV curve, the AP39811 creatively adopts a new control method, called Enhanced Cable Compensation method.

3. Constant Voltage Control

The output voltage is proportional to the auxiliary winding voltage during t_{ONS} period indicated by Formula 5. This auxiliary winding voltage is divided by resistors R_{FB1} and R_{FB2} before inputting to the FB pin. As Figure 3 illustrated, the AP39811 detects the FB voltage at the end of t_{SAMPLE} during t_{ONS} period, the detected voltage which reflects the output voltage is regulated to V_{FB} of 2.4V with the help of the constant voltage control block. To be compatible with different system designs and avoid the turn-off spike impact, the t_{SAMPLE} is designed to be part of t_{ONS} , usually 55% of t_{ONS} at light load and 60% of t_{ONS} at heavy load. For system design, adjusting the ratio of R_{FB1} and R_{FB2} can get the target output voltage value.

$$V_{AUX} = \frac{N_{AUX}}{N_S} \times (V_o + V_d) \quad (5)$$

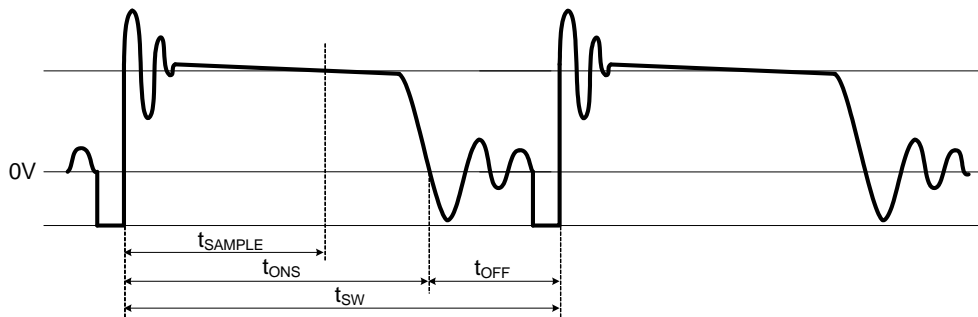

Figure 3. Auxiliary Voltage Waveform

NEW PRODUCT

Operation Description (continued)

4. Slanted Voltage Control

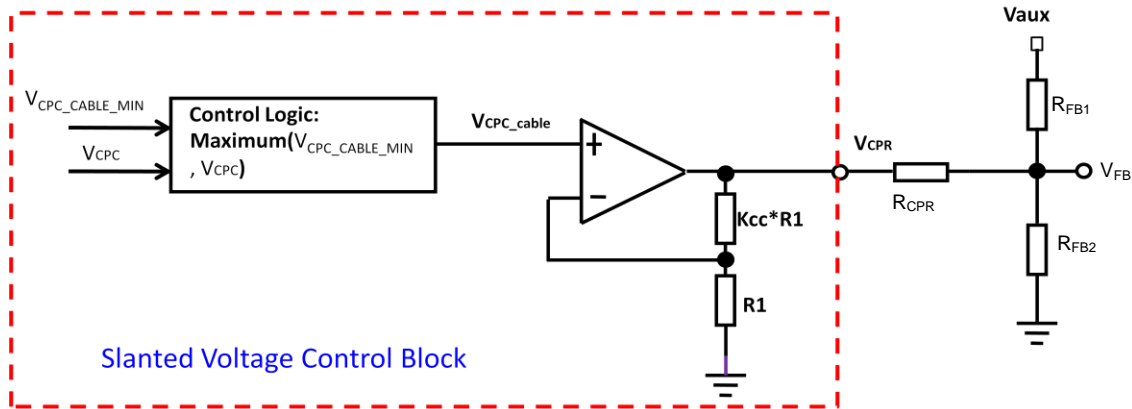

Figure 4. Slanted Voltage Control Block

In AP39811, an enhanced cable compensation method is introduced to achieve the slanted IV curve. As shown in Figure 4, the voltage on CPR pin represents the cable compensation voltage which is changed according to the load condition. The resistance R_{CPR} connected between CPR pin and FB pin is used to adjust the cable compensation value.

$$V_O = \frac{(V_{FB} - V_{CPR}) * R_{FB1} + \left(1 + \frac{R_{FB1}}{R_{FB2}}\right) * V_{FB}}{N_{as}} - V_d \quad (6)$$

Formula 6 indicates the mathematical relationship within all V_{OUT} -related parameters. V_{FB} is 2.4V regulated by constant voltage control block, N_{as} is the turns ratio of auxiliary winding turns to secondary winding turns, V_{CPR} is the CPR pin voltage, V_d is the forward voltage of secondary rectify diode, R_{FB1} and R_{FB2} are used as the voltage divider net. As it shows, the V_{CPR} will affect the V_{OUT} greatly and it is controlled by AP39811.

Figure 4 illustrates the control principle of slanted voltage control block, as it can be seen, V_{CPR} is proportional to V_{CPC_CABLE} , refer to Formula 7

$$V_{CPR} = V_{CPC_CABLE} * (1 + K_{CC}) \quad (7)$$

K_{CC} is an inner factor, for AP39811A, it is 1.5, while for AP39811B, it is 1.2. The V_{CPC_CABLE} is derived by comparing the $V_{CPC_CABLE_MIN}$ and V_{CPC} , the higher value is assigned to V_{CPC_CABLE} . V_{CPC} is an inner factor that is proportional to the output current and it directly indicates the load condition. $V_{CPC_CABLE_MIN}$ is a constant value, so $V_{CPC_CABLE_MIN}$ is constant, for AP39811A it is 1.4V and 2.14V for AP39811B, this parameter is fixed within AP39811, so the ratio of the inflection point of CV and SV to CC point is fixed. The higher the $V_{CPC_CABLE_MIN}$, the larger the ratio is. Figure 5 shows the relationship of V_{CPR} , V_{FB} and I_O . Before the inflection point, the V_{FB} and V_{CPR} are both constant and the constant output voltage is achieved. After the inflection point, the V_{CPR} increases along with the load current, which leads to a decreasing output voltage and the slanted output voltage part is formed. Note that when the V_{CPR} is lower than V_{FB} in range A, AP39811 has positive cable compensation and the compensation voltage is added to the V_{FB} -regulated voltage. In range B, the cable compensation is reversed and the compensation voltage is subtracted from the V_{FB} -regulated voltage.

Operation Description (continued)

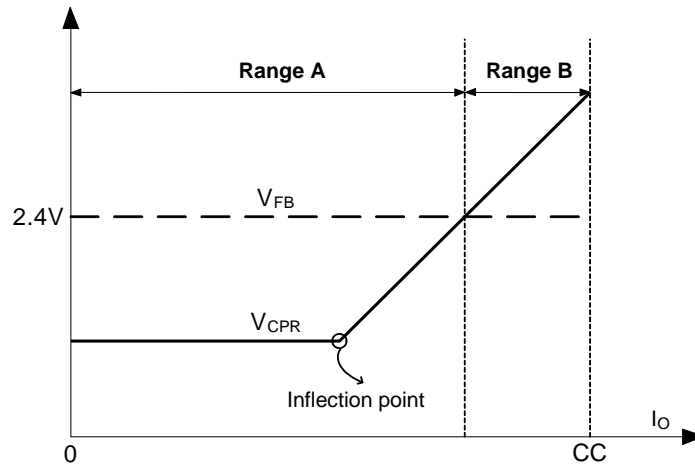

Figure 5: V_{CPR} and V_{FB} Versus I_o

5. Constant Current Control

In AP39811, Formula 8 shows the related parameters that determine the output current. To get a constant output current, the V_{CS} and t_{ONS}/t_{SW} is fixed in AP39811 during CC mode. Meanwhile, reliable control logic is integrated within AP39811 to ensure the system swift smoothly between CC mode and CV/SV mode.

$$I_{OUT} = \frac{1}{2} * \frac{N_p}{N_s} * I_{pk} * \frac{t_{ONS}}{t_{SW}} = \frac{1}{2} * \frac{N_p}{N_s} * \frac{V_{CS}}{R_{CS}} * \frac{t_{ONS}}{t_{SW}} \quad (8)$$

6. Multiple Segment Peak Current

In the original PFM PSR system, the switching frequency decreases with the decreasing output current, which will encounter audible noise issue when switching frequency decreases below 20kHz.

In order to avoid audible noise issue, the AP39811 uses 3-segment primary peak current control method at CV and SV mode, the current sense threshold voltage is piecewise defined. As shown in Figure 6, the low threshold V_{CS_L} is set under 3% CC load, the high threshold V_{CS_H} is set above 33% CC load. Within the range from 3% to 33%, the threshold V_{CS_M} increases basing on the load condition, the V_{CS_M} is carefully calculated inside the AP39811 to make the system operate at a constant switching frequency which is higher than 20kHz.

As for the special IV curve, the maximum switching frequency occurs at the slanted voltage mode. During this mode, the V_{CS} reaches its maximum threshold V_{CS_H} , so the frequency varies only with the input power, carefully select the primary inductance to get a reasonable frequency feature.

Operation Description (continued)

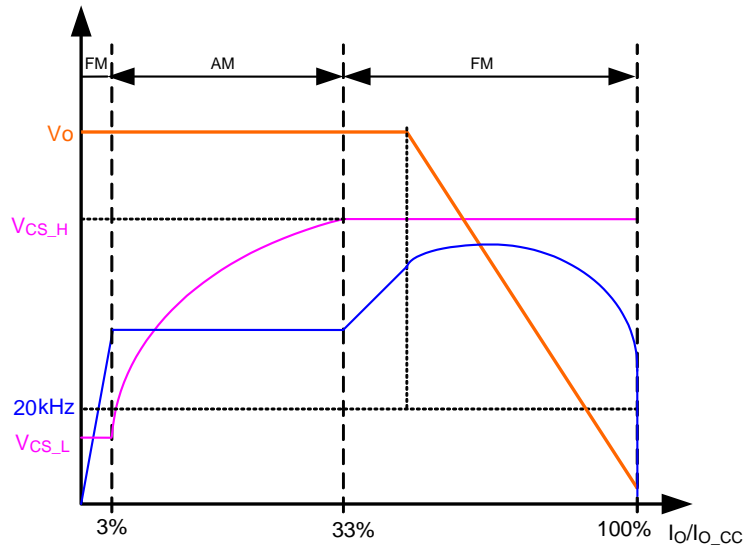

Figure 6: V_{CS} and f_S Versus I_o

7. Leading Edge Blanking

When the power switch is turned on, a turn-on spike will occur on the V_{CS} sense resistance. To avoid false-termination of the switching pulse, a 300ns leading-edge blanking is built in. During this blanking period, the current sense comparator is disabled and the primary MOSFET cannot be turned off.

8. Valley Turn-on

When the off time (t_{OFF}) is shorter than t_{VAL-ON} , the AP39811 power system can work with valley turn-on. It can reduce the switching-on power losses and achieve high overall efficiency. At the same time, because of valley turn-on the switching frequency has the random jitter feature, which will be beneficial to conductive EMI performance. And valley turn-on can also reduce the power switch turn-on spike current and then achieve the better radioactive EMI performance.

9. V_{CS} Jitter

Even though the valley turn-on function produces the random frequency jitter feature, an active frequency jitter function is added in the AP39811. The active frequency dithering is realized by applying variation on V_{CS} reference (V_{CS_REF}). The V_{CS_REF} is changed every 2 cycles and the period of variation is 12 cycles, which is shown as Figure 7. The variation between V_{CS4} and V_{CS1} is $\pm 3\%$ using the mean level as a reference.

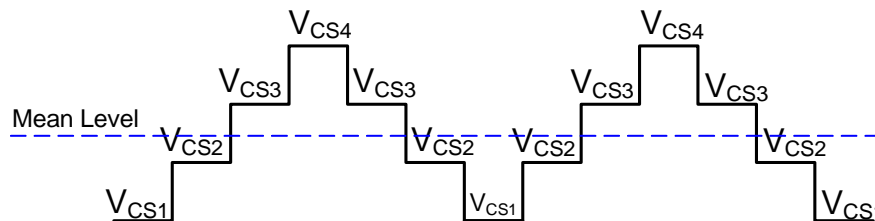

Figure 7: V_{CS} Jitter

10. Adjustable Line Compensation

In real system, there exists a delay time, from the V_{SOURCE} reach the inner V_{CS} threshold to the actual switch turn-off point. The delay time contains the propagation time of the inner comparator and the driver delay, and it does not change with line voltage. The delay time leads to different primary peak current under different line voltage, which results in different output current in CC mode.

Operation Description (continued)

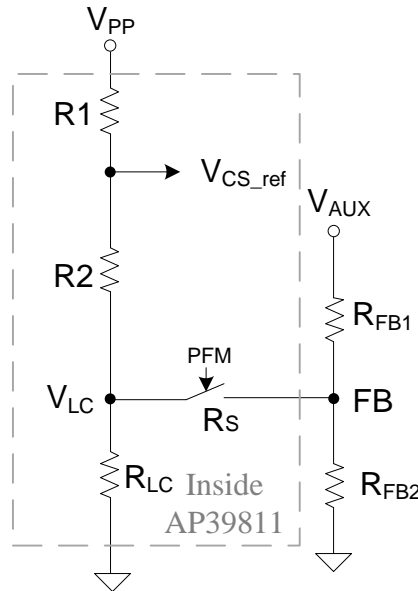

Figure 8: Line Compensation Control Circuit

In order to alleviate the difference under the universal input voltage, the AP39811 integrates the line compensation control circuit shown as Figure 8. During the primary on stage, an inner switcher R_S switches on, the R_{LC} is much smaller compared with R_{FB2} , so the R_{FB2} 's effect on line compensation can be neglected, the proportional line voltage is detected through R_{FB1} and R_{LC} , and is added to the V_{CS} threshold (V_{CS_REF}). The V_{LC} can be derived from the Formula 9:

$$V_{LC} = \frac{\frac{R_{FB1}}{3 * R2} * V_{PP} - V_{AUX}}{1 + \frac{R_{FB1}}{3 * R2} + \frac{R_{FB1}}{R_{LC}}} \quad (9)$$

The final compensated V_{CS} is :

$$V_{CS_REF} = \frac{1}{3} * V_{PP} + \frac{2}{3} * V_{LC} \quad (10)$$

In the above formulas, V_{PP} is 1.8V at CC mode, R_{LC} is 60Ω, $R2$ is 60kΩ, $R1$ is two times of $R2$, V_{AUX} is the auxiliary winding voltage during primary-on period, which is proportional to bus voltage. Based on the formula, we can make a conclusion that a smaller R_{FB1} results in deeper line compensation. If we know the delay time, t_{DELAY} , typically 150ns in AP39811, we can calculate the R_{FB1} as a reference for the system design.

11. Protection

The AP39811 provides versatile protections to prevent the system from damage under various fault conditions. Most protections will trigger auto-recovery mode in which the system will restart as soon as the V_{CC} drops to $V_{OPR(MIN)}$, when the fault conditions are removed, the system will recover to normal operation automatically.

V_{CC} OVP

A V_{CC} OVP threshold is set to protect the IC from damage. When the V_{CC} OVP protection is triggered, the IC will stop output drive signal immediately and the system will enter auto-recovery mode.

Output Over Voltage Protection (SOVP)

As it described above that the FB pin voltage during t_{ONS} reflects the output voltage proportionally, this voltage can be used to realize SOVP. The AP39811 set a higher threshold, $V_{FB(OVP)}$, to shut down the system if the sampled voltage reached the threshold continuously for 3 switching cycles, the SOVP will be triggered and the system will enter auto-recovery mode.

Operation Description (continued)

Transformer Anti-Saturation Protection

Under some fault conditions or bad system design, the transformer may approach saturation and the current increases dramatically. To avoid power device damage since of transformer saturation, AP39811 integrated a maximum V_{CS} threshold $V_{CS(MAX)}$ to protect the system, If there are 3 consecutive pulses where V_{CS} exceeds the threshold, the controller will shut down and enter auto-recovery mode.

Over Temperature Protection (OTP)

If the IC junction temperature exceeds the threshold of +130°C, the AP39811 will shut down immediately and enter auto-recovery mode. Note that even when the V_{CC} reaches V_{TH_ST} , the IC will not output any drive pulse until the junction temperature falls of a hysteresis temperature of +30°C.

Bulk Capacitor Open Protection

When the bulk capacitor opens, the bus voltage becomes a rectified half sine wave with large line frequency ripple. The IC can identify this fault by detecting bus voltage valley value. The AP39811 detects the bus voltage at each switching cycle through FB pin. If the detected voltage is lower than $V_{FB_NEG_L}$ for 3 consecutive switching cycles, the IC will shut down and enter auto-recovery mode. During the auto recovery mode, when the V_{CC} reaches the V_{TH_ST} , the controller will output one drive pulse to detect the bus voltage. If the detected signal is higher than $V_{FB_NEG_H}$, the IC will output subsequent pulses and the system will operate normally, otherwise the IC will shut down again and enter next restart cycle.

Ordering Information

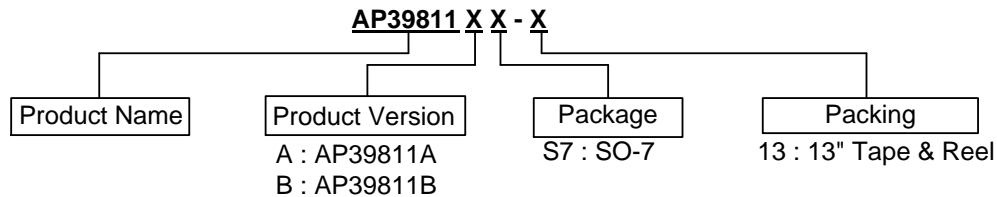

Package	Part Number	Marking ID	Packing
SO-7	AP39811AS7-13	39811A	4000/Tape & Reel
SO-7	AP39811BS7-13	39811B	4000/Tape & Reel

Marking Information

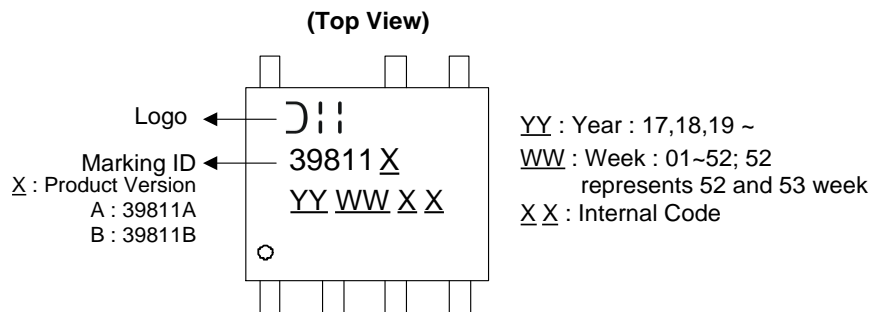

Package Outline Dimensions (All dimensions in mm (inch).)

Please see <http://www.diodes.com/package-outlines.html> for the latest version.

(1) Package Type: SO-7

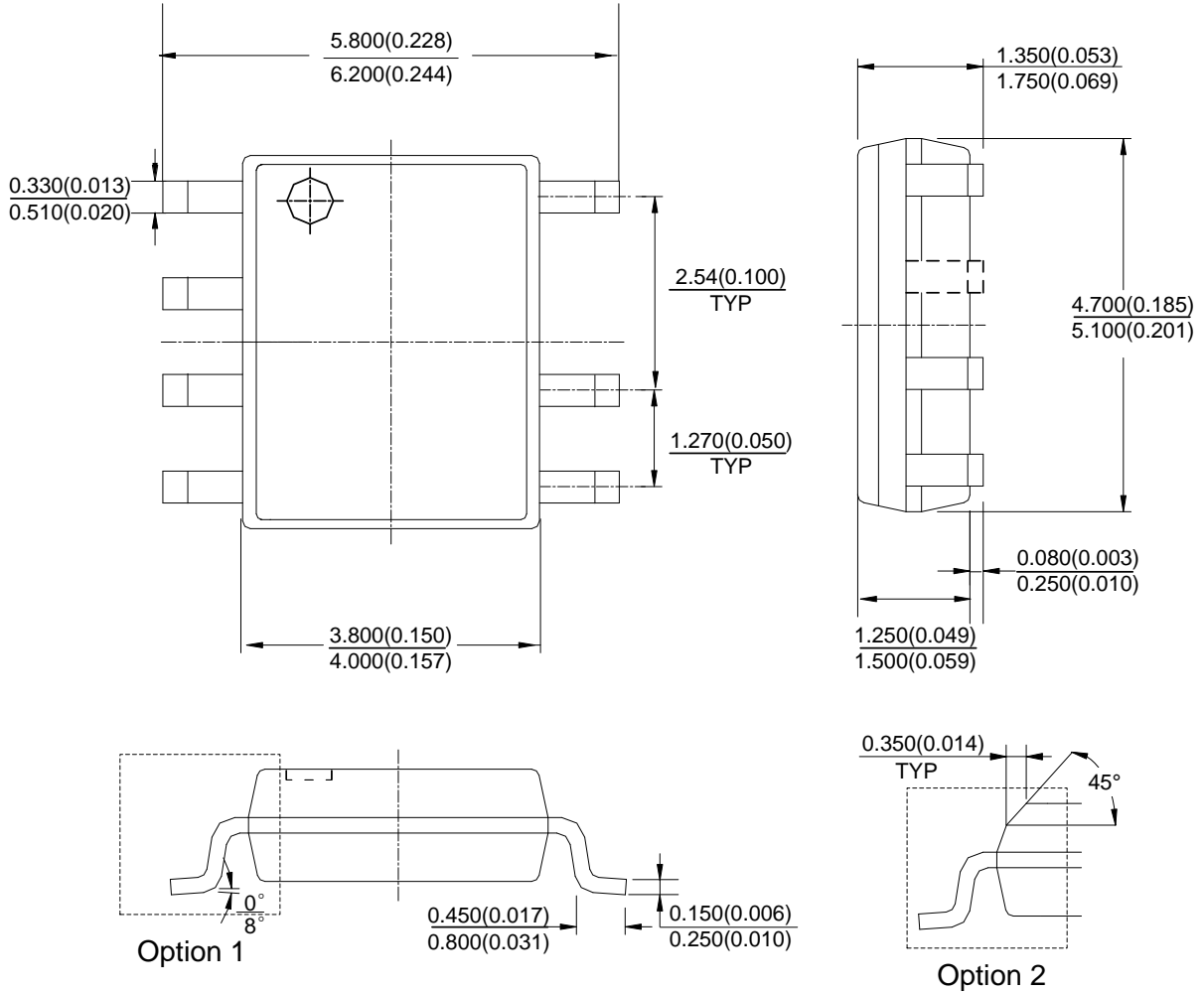

Note: Eject hole, oriented hole and mold mark is optional.

NEW PRODUCT

Suggested Pad Layout

Please see <http://www.diodes.com/package-outlines.html> for the latest version.

(1) Package Type: SO-7

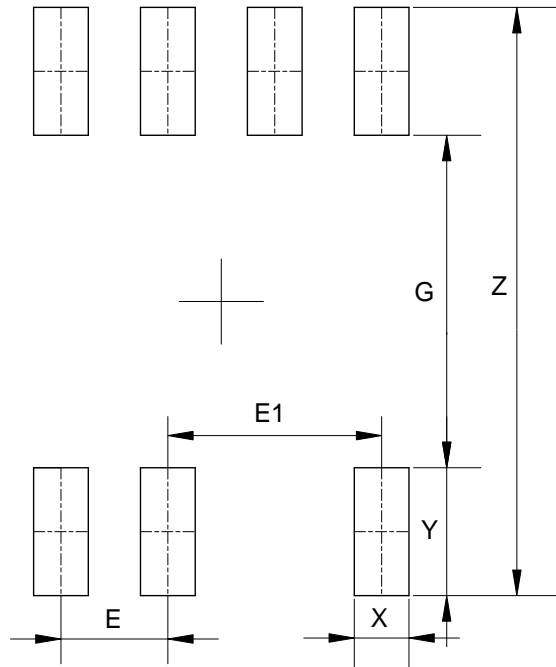

Dimensions	Z (mm)/(inch)	G (mm)/(inch)	X (mm)/(inch)	Y (mm)/(inch)	E (mm)/(inch)	E1 (mm)/(inch)
Value	6.900/0.272	3.900/0.154	0.650/0.026	1.500/0.059	1.270/0.050	2.540/0.100

NEW PRODUCT

IMPORTANT NOTICE

DIODES INCORPORATED MAKES NO WARRANTY OF ANY KIND, EXPRESS OR IMPLIED, WITH REGARDS TO THIS DOCUMENT, INCLUDING, BUT NOT LIMITED TO, THE IMPLIED WARRANTIES OF MERCHANTABILITY AND FITNESS FOR A PARTICULAR PURPOSE (AND THEIR EQUIVALENTS UNDER THE LAWS OF ANY JURISDICTION).

Diodes Incorporated and its subsidiaries reserve the right to make modifications, enhancements, improvements, corrections or other changes without further notice to this document and any product described herein. Diodes Incorporated does not assume any liability arising out of the application or use of this document or any product described herein; neither does Diodes Incorporated convey any license under its patent or trademark rights, nor the rights of others. Any Customer or user of this document or products described herein in such applications shall assume all risks of such use and will agree to hold Diodes Incorporated and all the companies whose products are represented on Diodes Incorporated website, harmless against all damages.

Diodes Incorporated does not warrant or accept any liability whatsoever in respect of any products purchased through unauthorized sales channel. Should Customers purchase or use Diodes Incorporated products for any unintended or unauthorized application, Customers shall indemnify and hold Diodes Incorporated and its representatives harmless against all claims, damages, expenses, and attorney fees arising out of, directly or indirectly, any claim of personal injury or death associated with such unintended or unauthorized application.

Products described herein may be covered by one or more United States, international or foreign patents pending. Product names and markings noted herein may also be covered by one or more United States, international or foreign trademarks.

This document is written in English but may be translated into multiple languages for reference. Only the English version of this document is the final and determinative format released by Diodes Incorporated.

LIFE SUPPORT

Diodes Incorporated products are specifically not authorized for use as critical components in life support devices or systems without the express written approval of the Chief Executive Officer of Diodes Incorporated. As used herein:

A. Life support devices or systems are devices or systems which:

1. are intended to implant into the body, or
2. support or sustain life and whose failure to perform when properly used in accordance with instructions for use provided in the labeling can be reasonably expected to result in significant injury to the user.

B. A critical component is any component in a life support device or system whose failure to perform can be reasonably expected to cause the failure of the life support device or to affect its safety or effectiveness.

Customers represent that they have all necessary expertise in the safety and regulatory ramifications of their life support devices or systems, and acknowledge and agree that they are solely responsible for all legal, regulatory and safety-related requirements concerning their products and any use of Diodes Incorporated products in such safety-critical, life support devices or systems, notwithstanding any devices- or systems-related information or support that may be provided by Diodes Incorporated. Further, Customers must fully indemnify Diodes Incorporated and its representatives against any damages arising out of the use of Diodes Incorporated products in such safety-critical, life support devices or systems.

Copyright © 2019, Diodes Incorporated

www.diodes.com

Looking for pricing, stock, or lifecycle information?

Click below to explore more details on WIN SOURCE:

 [View AP39811AS7-13 on WIN SOURCE](#)

 [Diodes Incorporated](#) Information

Optimize Your Supply Chain with WIN SOURCE Solutions

-  Global Sourcing Solution
-  Obsolete Management
-  Cost Control Management
-  Shortage Management
-  Alternative Solution
-  Excess Inventory Management