



**THE DATASHEET OF  
BD86123AEFJ-E2**



# 4.5V to 18V, 3A 1ch Synchronous Buck Converter



## BD86123AEFJ

### ●Description

The BD86123AEFJ is synchronous buck converters. The device integrates power MOSFETS that provide a each maximums current output current continuous load current over a wide operating input voltage of 4.5V to 18V.

Current mode operation provides fast transient response and easy phase compensation.

The output power MOSFETS using P-type MOSEFT (HI side) and N-type MOSEFT (LOW side), then this device don't need boot capacitor.

The BD86123AEFJ is HTSOP-J8 standard packages.

### ●Applications

- LCD TVs
- Set top boxes
- DVD/Blu-ray players/recorders
- Broadband Network and Communication Interface
- Amusement, other

### ●Features

- Input voltage range: 4.5V to 18.0V
- Reference voltage 0.8V ± 1%
- Average output Current: 3A(Max.)
- Switching frequency: 550kHz(Typ.)
- Pch FET ON resistance: 90mΩ (Typ.)
- Nch FET ON resistance: 50mΩ (Typ.)
- Standby current: 1μA (Typ.)
- Operating temperature range: -40°C to +85°C
- Cycle by cycle over current protection(OCP)
- Thermal shutdown (TSD)
- Under voltage lock out(UVLO)
- Short circuit protection(SCP)
- Over voltage protection(OVP)
- Fixed soft start 5msec

### ●Package

HTSOP-J8

W(Typ.) x D(Typ.) x H(Max.)  
4.90mm x 6.00mm x 1.00mm

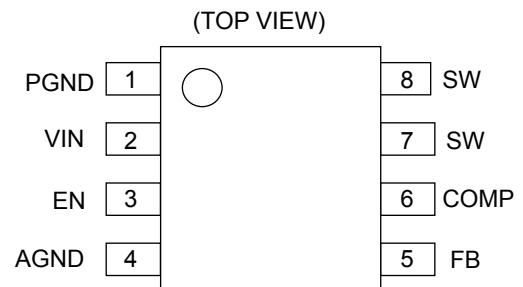

Figure 2. Pin configuration

### ●Typical Application

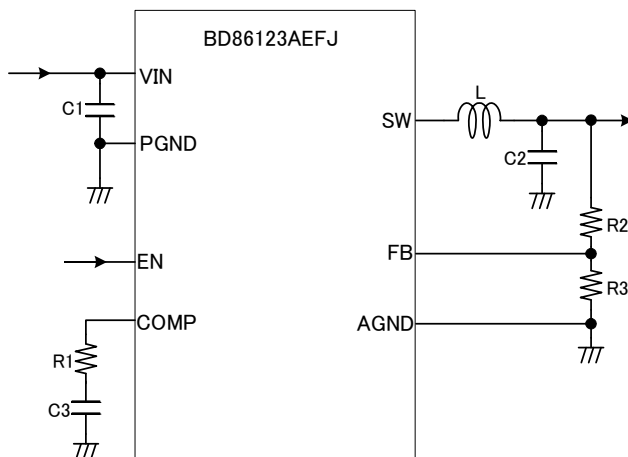

Figure 1. Application Circuit

●Block Diagram

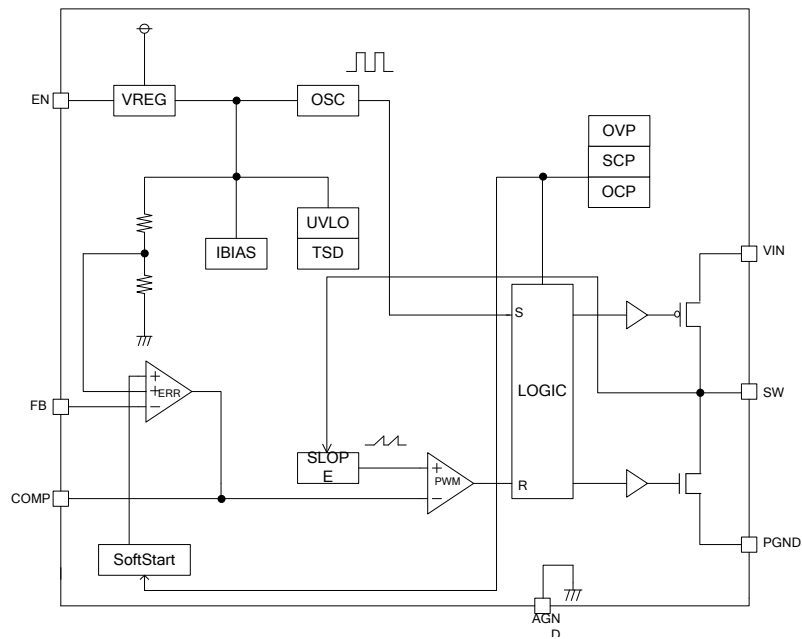

Figure 3. Block diagram

●Pin Description

No.	Symbol	Description
1	PGND	Power Ground pin. Power ground return for switching circuit.
2	VIN	Input voltage supply pin.
3	EN	Enable input control. Active high.
4	AGND	Analog Ground pin. Electrically needs to be connected to PGND.
5	FB	Converter feedback input. Connect to output voltage with feedback resistor divider.
6	COMP	Error amplifier output, and input to the output switch current comparator. External loop compensation pin.
7	SW	Switch node connection between high-side Pch FET and Low-side Nch FET.
8	SW	Switch node connection between high-side Pch FET and Low-side Nch FET.
Thermal Pad	Back side	Thermal pad of the package. Must be soldered to achieve appropriate dissipation. Must be connected to AGND.

**●Absolute maximum ratings (Ta=25°C)**

Parameter	Symbol	Ratings	Unit	Condition
Input supply voltage	V <sub>IN</sub>	20	V	
SW terminal voltage	V <sub>SW</sub>	20	V	
EN terminal voltage	V <sub>EN</sub>	20	V	
Power dissipation	P <sub>d</sub>	3760*	mW	70mm×70mm, thickness 1.6mm, and 4 layer glass epoxy substrates
Operating temperature	T <sub>opr</sub>	-40~+85	°C	
Storage temperature	T <sub>stg</sub>	-55~+150	°C	
Maximum Junction temperature	T <sub>jmax</sub>	150	°C	
FB, COMP terminal voltage	VLVPINS	7	V	

\* Operating at higher than Ta=25°C, 30.08mW shall be reduced per 1°C

**●Operating conditions**

Parameter	Symbol	Ratings			Unit
		Min.	Typ.	Max.	
Input supply voltage	V <sub>IN</sub>	4.5	-	18.0	V
Output current	I <sub>OUT</sub>	-	-	5.0	A
Output voltage range	V <sub>RANGE</sub>	V <sub>IN</sub> × 0.08*	-	V <sub>IN</sub> × 0.8	V

\* V<sub>IN</sub> × 0.08 ≥ 0.8 [V]

## ●Electrical characteristics

(Unless otherwise noted Ta=25°C, V<sub>IN</sub>=12V, V<sub>EN</sub> = 3V)

Parameter	Symbol	Limits			UNIT	Condition
		Min.	Typ.	Max.		
V <sub>IN</sub> supply current (operating)	I <sub>Q_active</sub>	-	1.5	2.5	mA	V <sub>FB</sub> = 0.75V, V <sub>EN</sub> = 5V
V <sub>IN</sub> supply current (standby)	I <sub>Q_stby</sub>	-	1.0	10.0	μA	V <sub>EN</sub> = 0V
Reference voltage (VREF)	V <sub>FB</sub>	0.792	0.800	0.808	V	FB-COMP Short (Voltage follower)
FB input bias current	I <sub>FB</sub>	-	0	2	μA	
Oscillation frequency	f <sub>OSC</sub>	500	550	600	kHz	
High side FET ON resistance	R <sub>ONH</sub>	-	90	-	mΩ	V <sub>IN</sub> = 12V , I <sub>SW</sub> = -1A
Low side FET ON resistance	R <sub>ONL</sub>	-	50	-	mΩ	V <sub>IN</sub> = 12V , I <sub>SW</sub> = -1A
SW leak current	I <sub>LSW</sub>	-	0	5	μA	V <sub>IN</sub> = 18V , V <sub>SW</sub> = 18V
Switch Current Limit	I <sub>LIMIT</sub>	3.7	-	-	A	
Min duty	Min_duty	-	-	8	%	
UVLO voltage	V <sub>UVLO</sub>	3.8	4.1	4.4	V	V <sub>IN</sub> Sweep up
UVLO hysteresis	V <sub>UVLOHYS</sub>	-	0.3	-	V	
EN terminal H threshold voltage	V <sub>ENH</sub>	2.0	-	-	V	
EN terminal L threshold voltage	V <sub>ENL</sub>	-	-	0.8	V	
Soft Start Time	T <sub>SS</sub>	3.0	5.0	7.0	msec	

- V<sub>FB</sub>:FB terminal voltage, V<sub>EN</sub>:EN terminal voltage,
- Current capability should not exceed Pd.

● Typical Performance Curves (Reference data)

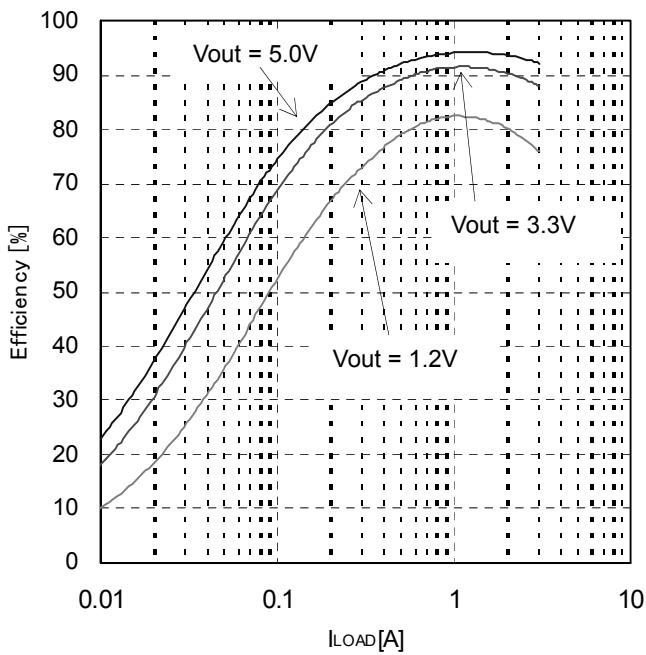

Figure 4. Efficiency  
(VIN=12V, L=3.3/4.7/4.7μH(Vout=1.2/3.3/5.0V), Cout=44μF)

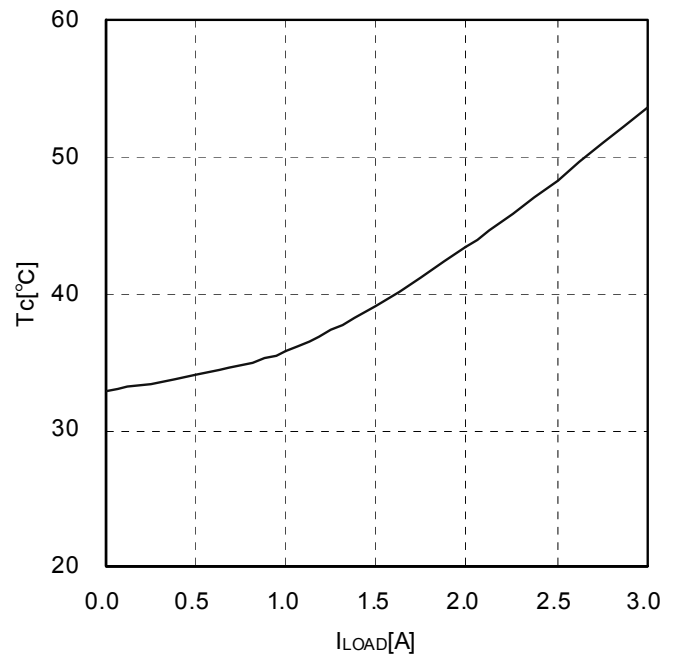
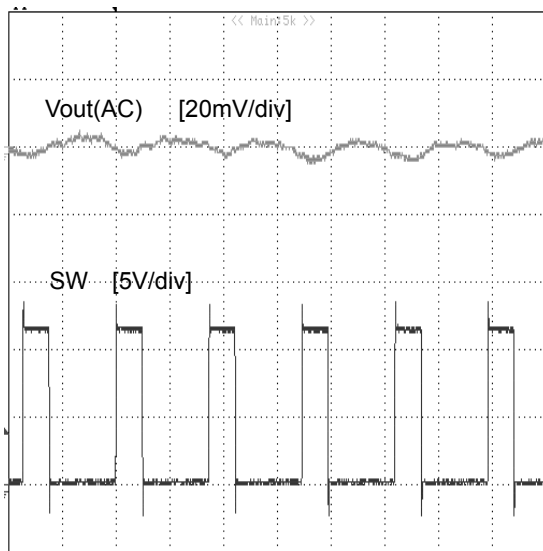
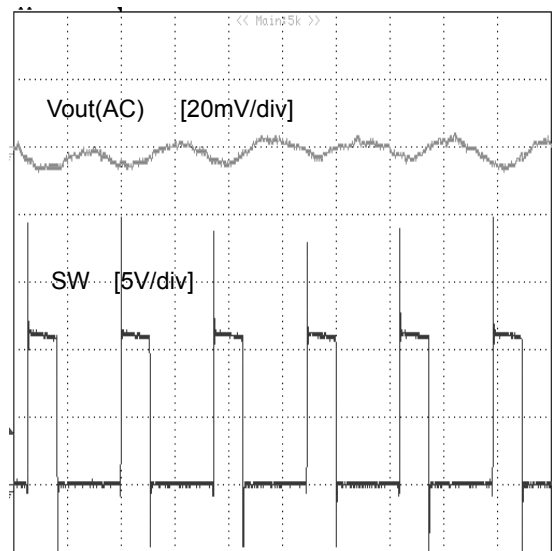

Figure 5. T<sub>C</sub>-I<sub>LOAD</sub>  
(VIN=12V, Vout=3.3V, L=4.7μH, Cout=44μF)



T - Time - 1μsec/div

Figure 6. Vout Ripple  
(VIN=12V, Vout=3.3V, L=4.7μH, Cout=44μF, Iout=0A)



T - Time - 1μsec/div

Figure 7. Vout Ripple  
(VIN=12V, Vout=3.3V, L=4.7μH, Cout=44μF, Iout=3A)

● Typical Performance Curves (Reference data) (continued)

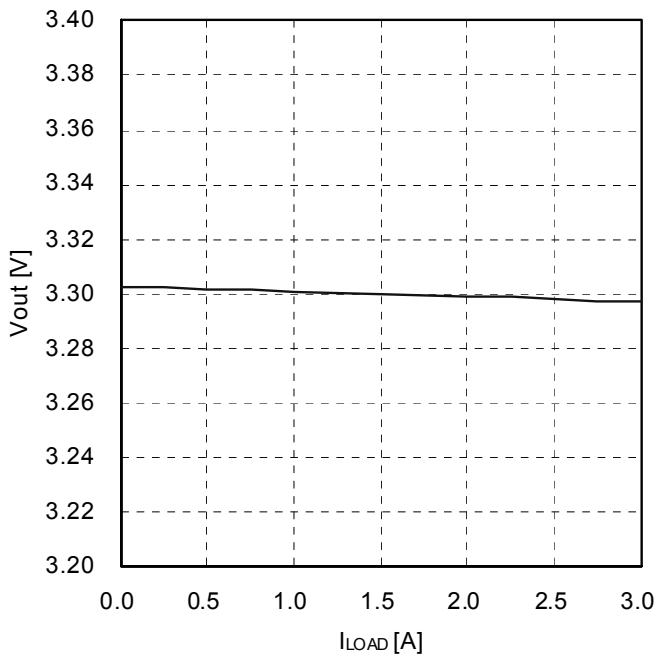

Figure 8. Load regulation  
(V<sub>IN</sub>=12V, V<sub>out</sub>=3.3V, L=4.7μH, C<sub>out</sub>=44μF)

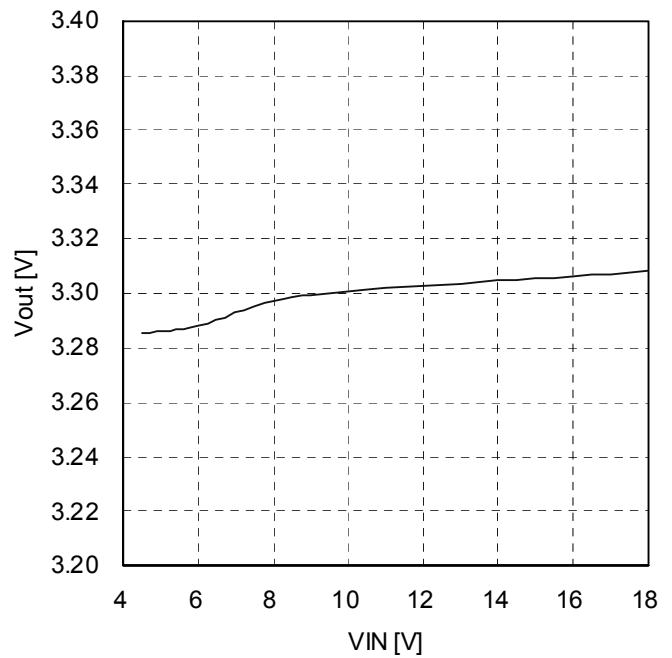

Figure 9. Line regulation  
(V<sub>out</sub>=3.3V, L=4.7μH, C<sub>out</sub>=44μF, I<sub>out</sub>=0A)

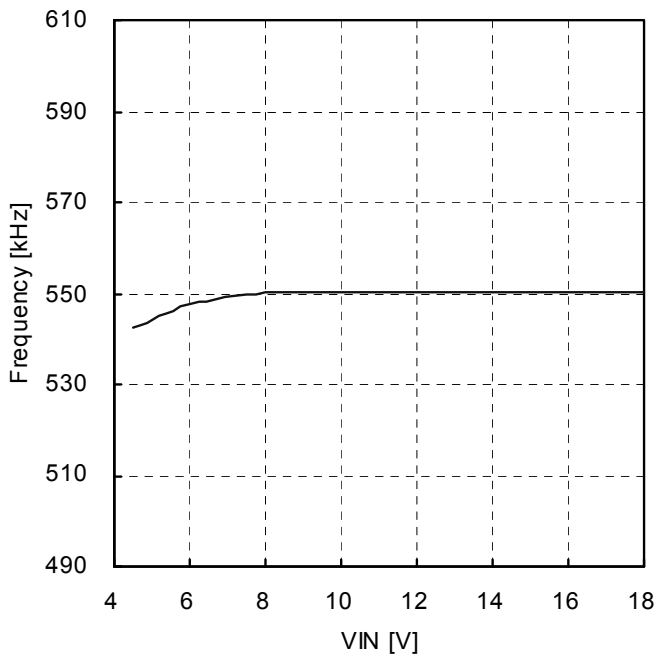

Figure 10. Frequency  
(V<sub>out</sub>=3.3V, L=4.7μH, C<sub>out</sub>=44μF, I<sub>out</sub>=0A)

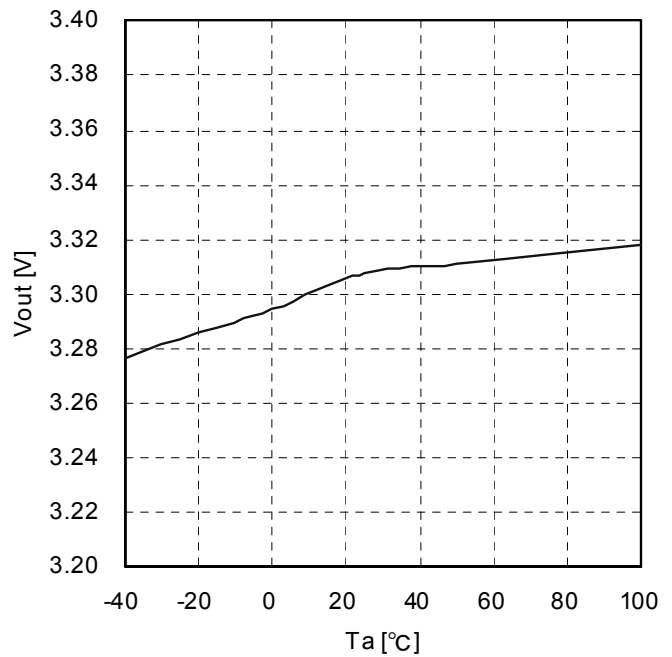
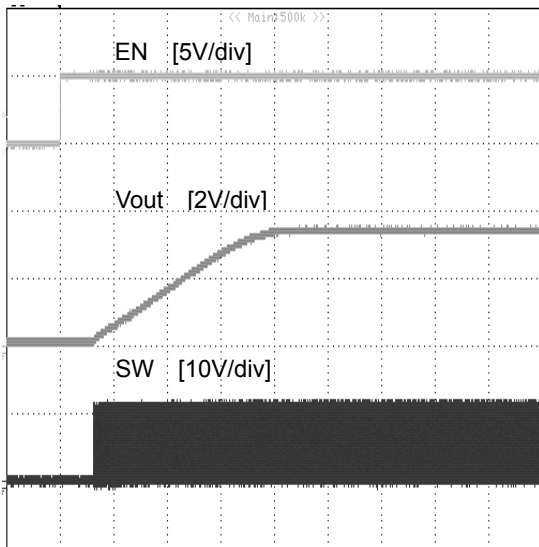

Figure 11. V<sub>out</sub>-Temperature  
(V<sub>in</sub>=12V, V<sub>out</sub>=3.3V, L=4.7μH, C<sub>out</sub>=44μF, I<sub>out</sub>=0A)

● Typical Performance Curves (Reference data) (continued)



T - Time – 1msec/div

Figure 12. Start up wave form  
(Vin=12V, Vout=3.3V, L=4.7μH, Cout=44μF, Iout=0A)

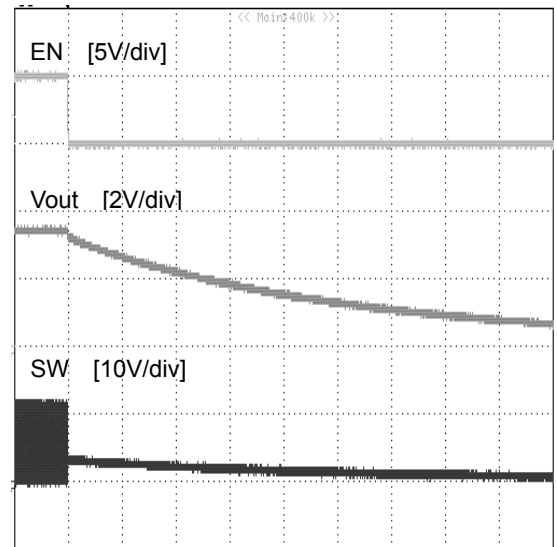

T - Time – 200msec/div

Figure 13. Off wave form  
(Vin=12V, Vout=3.3V, L=4.7μH, Cout=44μF, Iout=0A)

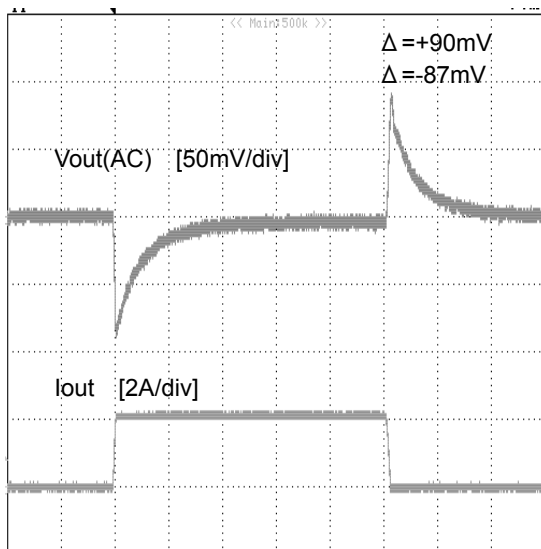

T - Time - 100μsec/div

Figure 14. Transient response  
(Vin=12V, Vout=3.3V, L=4.7μH, Cout=44μF, Iout=2A)

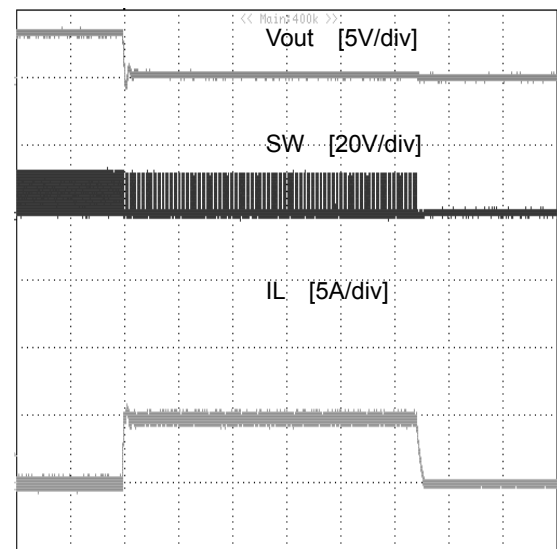

T - Time - 200μsec/div

Figure 15. OCP function  
(Vin=12V, Vout=3.3V, L=4.7μH, Cout=44μF, Vout is short to GND)

●Functional descriptions

**1 Enable control**

The device can be controlled ON/OFF by EN terminal voltage.

An internal circuit starts when VEN reaches 2.0V.

When standing up of VIN is too steep (1msec or less), a defective start might be caused according to the state of Pascon between GND substrate pattern and power supply-when the terminal EN is short-circuited to the terminal VIN and it is used.

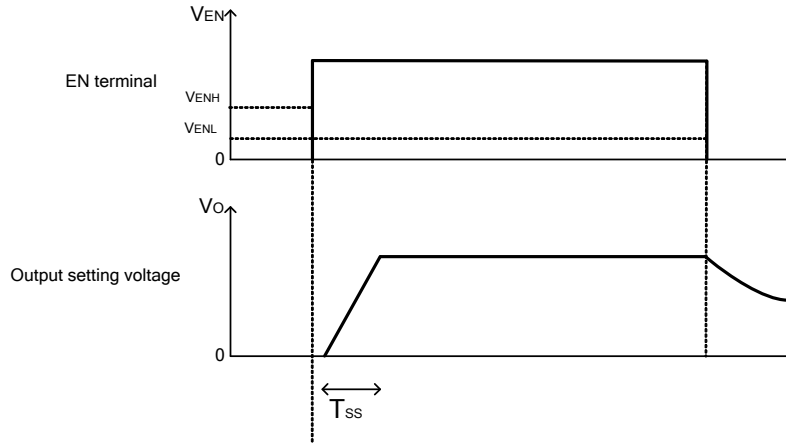

Figure 16. ON/OFF transition wave form in EN controlling

**2 Protection function**

**Protection circuit is effective for destruction prevention due to accident so that avoid using under continuous protection operation.**

**2-1 Short Circuit protection function (SCP)**

The FB terminal voltage is compared with internal reference voltage VREF.

If FB terminal voltage falls below  $V_{SCP}$  (= VREF - 240mV) and the state continues, output changes to low voltage and the state is fixed.

During soft start, the FB terminal voltage is compared with internal soft start slope

Table 1. output short circuit protection function

EN terminal	FB terminal	Short Circuit Protection function	Short Circuit Protection operation
$>V_{ENH}$	$<V_{SCP}$	Effective	ON
	$>V_{SCP}$		OFF
$<V_{ENL}$	-	Invalidity	OFF

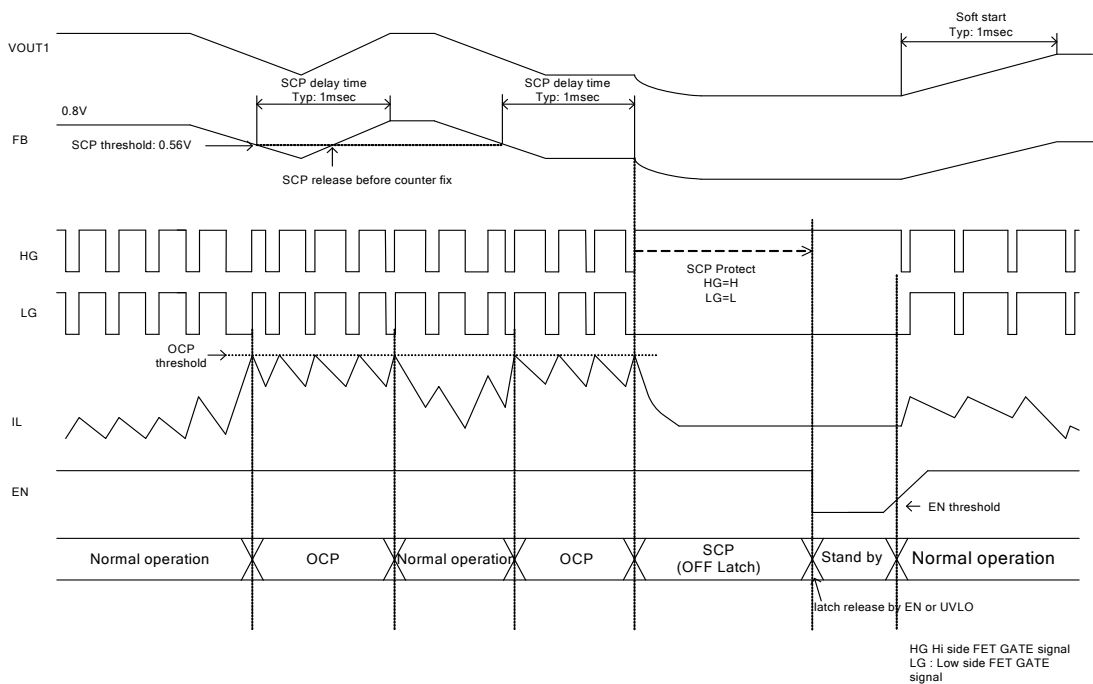

Figure 17. SCP Timing chart

**2-2 Over voltage protection function (OVP)**

Output over Voltage Protection is activated when FB voltage rises to or above  $V_{OVP}$  ( $= V_{REF} + 240mV$ ) and the state continues, output changes to low voltage and the state is fixed.

Table 2. output over voltage protection function

EN terminal	FB terminal	Short Circuit Protection function	Short Circuit Protection operation
$>V_{ENH}$	$>V_{OVP}$	Effective	ON
	$<V_{OVP}$		OFF
$<V_{ENL}$	-	Invalidity	OFF

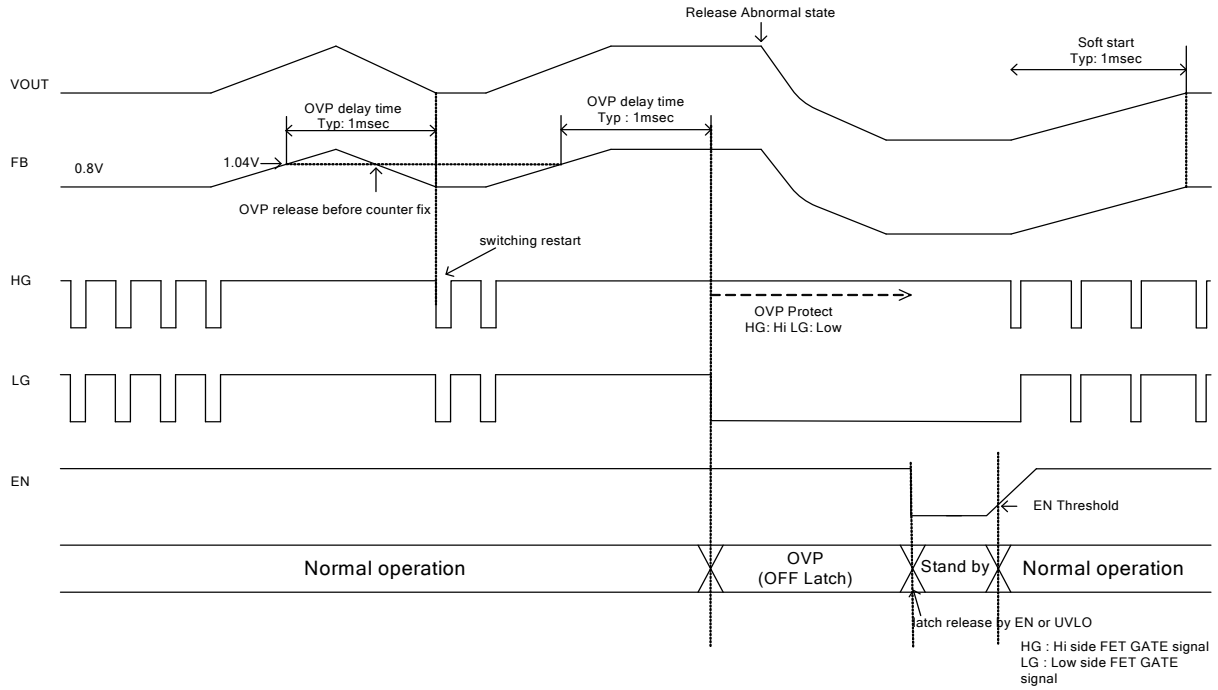

Figure 18. OVP Timing chart

**2-3 Under voltage lock out protection (UVLO)**

Under voltage lock out protection monitors the VIN terminal voltage. When the VIN terminal voltage is lower than 3.8V (typ), the device state changes to the standby mode. When the VIN terminal voltage is higher than 4.1V (typ), the device starts operation.

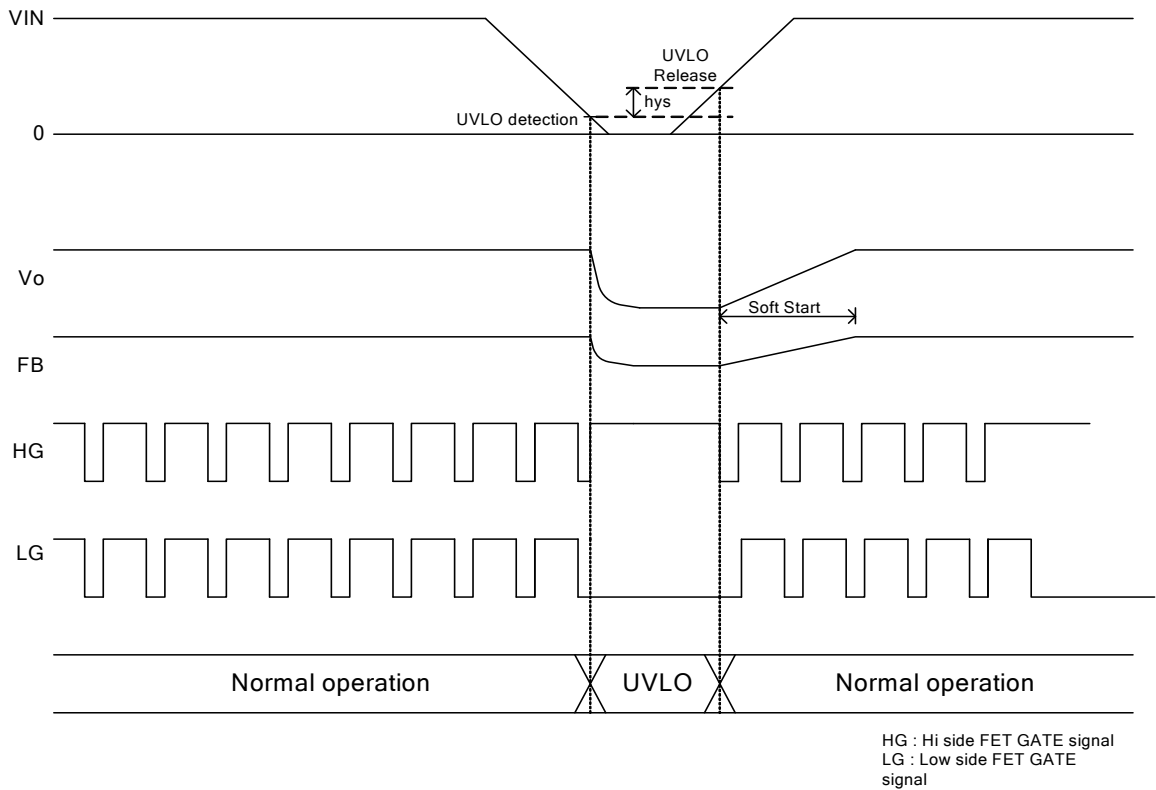

Figure 19. UVLO Timing chart

**2-4 Thermal shut down function**

BD86123A monitors the temperature of itself. When the temperature of the chip exceeds  $T_j=175$ , the DC/DC converter is fixed in a low voltage.

TSD function is aimed to shut down IC from thermal reckless driving under an abnormal state to exceed  $T_{jmax}=150$ . It aims at neither protection nor the guarantee of the set. Therefore, please do not use this function to protect the set.

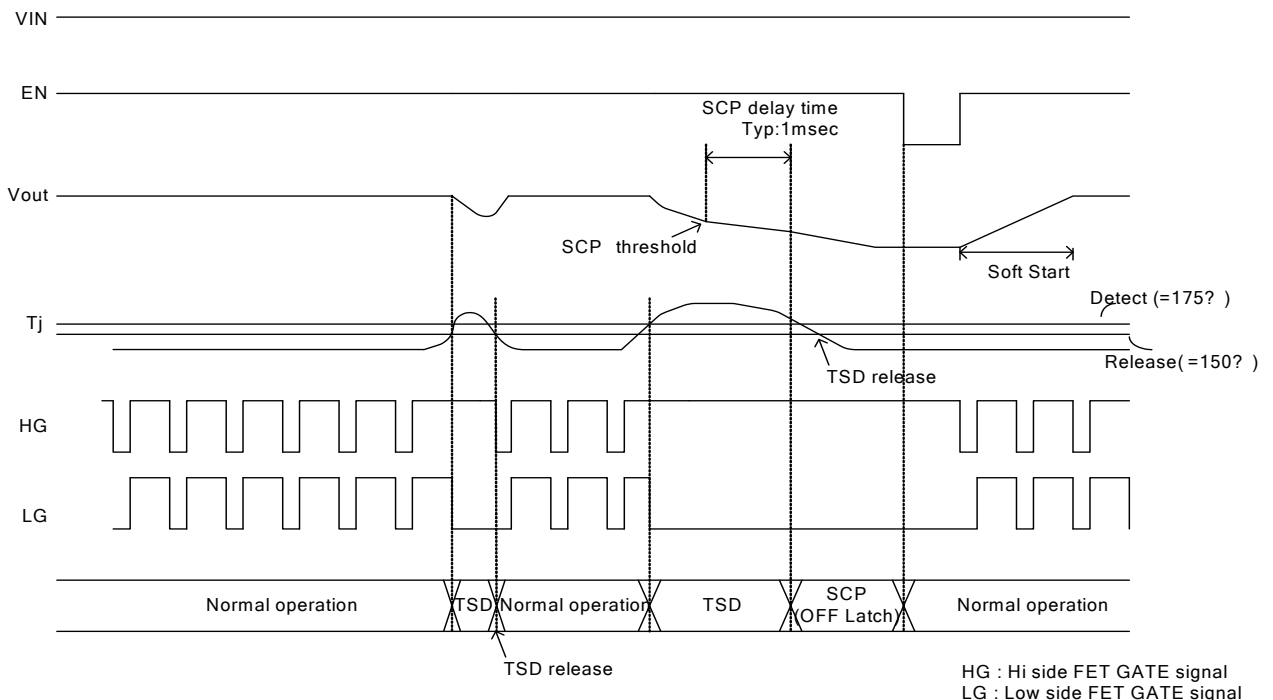

Figure 20. TSD Timing chart

**2-5 Over current protection function**

The over current protection function has been achieved by limiting the current that flows on high side MOSFET. Output current is limited by cycle-by-cycle. When an abnormal state continues, the output is fixed in a low level.

**2-6 Error detection (off latch) release method**

BD86123A enters the state of off latch when the protection function operates.

To release the off latch state, the VIN terminal voltage should be changed to less than UVLO level (=3.8V [typ] ) or, the EN terminal voltage falls below V<sub>ENL</sub>.voltage.

●Application Example(s)

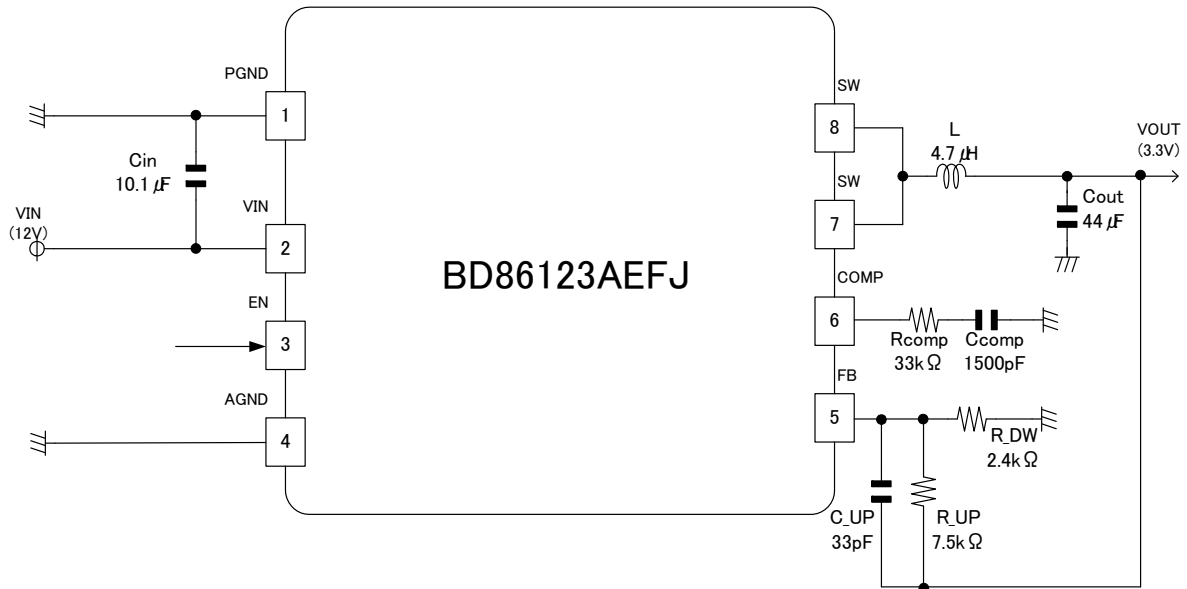

Figure 21. Application circuit

However, the best values of Application Components are different between applications. please confirm actual application and decide values finally.

		Maker	Part No
Input capacitor(Cin)	10µF/25V + 0.1µF/50V	TDK	C3225JB1E106K + C1608JB1H104K
Output capacitor(Cout)	22µF/16V × 2	TDK	C3216JB1C226M × 2
Inductor (L)	4.7µH	TDK	SPM6530-4R7

Vo(V)	FB	
	R_UP [kΩ]	R_DW [kΩ]
5	4.3	0.82
3.3	7.5	2.4
1.8	15	12
1.5	16	18
1.2	10	20
1	5.1	20

●How to select parts of application

(1) Output LC filter constant selection

The Output LC filter is required to supply constant current to the output load. A larger value inductance at this filter results in less inductor ripple current( $\Delta I_L$ ) and less output ripple voltage. However, the larger value inductors tend to have less fast load transient-response, a larger physical size, a lower saturation current and higher series resistance. A smaller value inductance has almost opposite characteristics above. So Choosing the Inductor ripple current( $\Delta I_L$ ) between 20 to 40% of the averaged inductor current (equivalent to the output load current) is a good compromise.

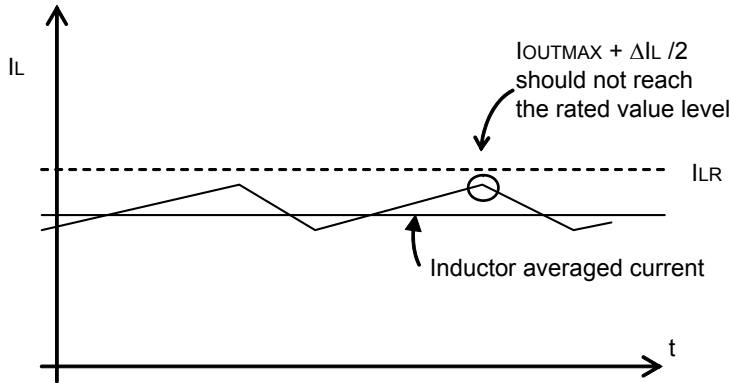

Figure 22.

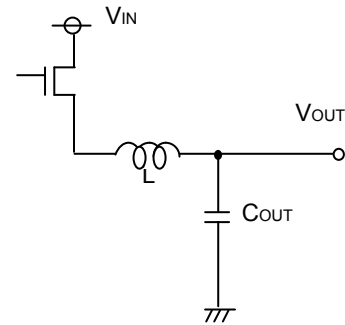

Figure 23.

Setting  $\Delta I_L = 30\% \times \text{Averaged Inductor current (3A)} = 0.9 \text{ [A]}$ ,

$$L = \frac{V_{OUT} \times (V_{IN} - V_{OUT})}{V_{IN} \times F_{OSC} \times \Delta I_L} = 4.83 \mu \text{ [H]} \approx 4.7 \mu \text{ [H]}$$

Where  $V_{IN} = 12\text{V}$ ,  $V_{OUT} = 3.3\text{V}$ ,  $F_{OSC} = 550 \text{ kHz}$ ,  
;  $F_{OSC}$  is a switching frequency

Also the inductor should have the higher saturation current than  $I_{OUTMAX} + \Delta I_L / 2$ .

The output capacitor  $C_{OUT}$  affects the output ripple-voltage. Choose the large capacitor to achieve the small ripple-voltage enough to meet the application requirement.

Output ripple voltage  $\Delta V_{RPL}$  is calculated by the following equation.

$$\Delta V_{RPL} = \Delta I_L \times \left( R_{ESR} + \frac{1}{8 \times C_{OUT} \times F_{OSC}} \right) \text{ [V]}$$

Where  $R_{ESR}$  is a parasitic series resistance in output capacitor.

Setting  $C_{OUT} = 44 \mu\text{F}$ ,  $R_{ESR} = 10 \text{ m}\Omega$   
 $\Delta V_{RPL} = 0.9 \times (10 \text{ m} + 1 / (8 \times 44 \mu \times 550 \text{ k})) = 13.6 \text{ mV}$

(2) Design of Feedback Resistance constant

Set the feedback resistance as shown below.

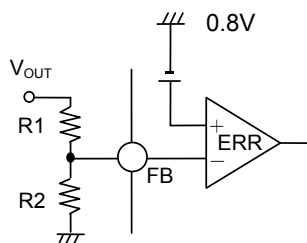

Figure 24.

$$V_{OUT} = \frac{R1 + R2}{R2} \times 0.8 \text{ [V]}$$

**(3) Loop Compensation**

Choosing compensation capacitor  $C_{CMP}$  and resistor  $R_{CMP}$

The current-mode buck converter has 2-poles and 1-zero system. Choosing the compensation resistor and capacitor is important for a good load-transient response and good stability.

The example of DC/DC converter application bode plot is shown below.

The compensation resistor  $R_{CMP}$  will decides the cross over frequency  $F_{CRS}$  (the frequency that the total DC-DC loop-gain falls to 0dB).

Setting the higher cross over frequency achieves good response speed, however less stability. While setting the lower cross over frequency shows good stability but worse response speed.

The 1/10 of switching frequency for the cross over frequency shows a good performance at most applications.

( i ) Choosing phase compensation resistor  $R_{CMP}$

The compensation resistor  $R_{CMP}$  can be on following formula.

$$R_{CMP} = \frac{2\pi \times V_{OUT} \times F_{CRS} \times C_{OUT}}{V_{FB} \times G_{MP} \times G_{MA}} \quad [\Omega]$$

Where

$V_{OUT}$  ; Output voltage,  $F_{CRS}$  ; Cross over frequency,  $C_{OUT}$  ; Output Capacitor,

$V_{FB}$  ; internal feedback voltage (**0.8V(TYP)**),

$G_{MP}$  ; Current Sense Gain (**4.3A/V(TYP)**) ,  $G_{MA}$  ; Error Amplifier Trans-conductance (**400 $\mu$ A/V(TYP)**)

Setting  $V_{OUT}= 3.3V$ ,  $F_{CRS}= 55kHz$ ,  $C_{OUT}= 44\mu F$ ,

$$R_{CMP} = \frac{2\pi \times 3.3 \times 55k \times 44\mu}{0.8 \times 4.3 \times 400\mu} = 37.3k \approx 33k \quad [\Omega]$$

( ii ) Choosing phase compensation capacitor  $C_{CMP}$

For the stability of DC/DC converter, canceling the phase delay that derives from output capacitor  $C_{OUT}$  and resistive load  $R_{OUT}$  by inserting the phase advance.

The phase advance can be added by the zero on compensation resistor  $R_{CMP}$  and capacitor  $C_{CMP}$ .

Making  $F_z= F_{CRS} / 6$  gives a first-order estimate of  $C_{CMP}$ .

Compensation Capacitor  $C_{CMP} = \frac{V_{out} \times C_{out}}{I_{out} \times R_{CMP}} \quad [F]$

Compensation Capacitor  $C_{CMP} = \frac{3.3 \times 44\mu}{3 \times 33k} = 1.47n \approx 1.5n \quad [F]$

However, the best values of zero and  $F_{CRS}$  are different between applications. After calculation above formula and confirmation actual application, please decide values finally.

( iii ) The condition of the loop compensation stability

The stability of DC/DC converter is important. To secure the operating stability, please check the loop compensation has the enough phase-margin. For the condition of loop compensation stability, the phase-delay must be less than 150 degree where Gain is 0 dB.

Feed forward capacitor  $C_{RUP}$  boosts phase margin over a limited frequency range and is sometimes used to improve loop response.  $C_{RUP}$  will be more effective if  $R_{UP} \gg R_{UP}||R_{DW}$

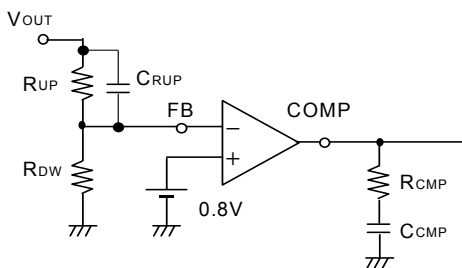

Figure 25.

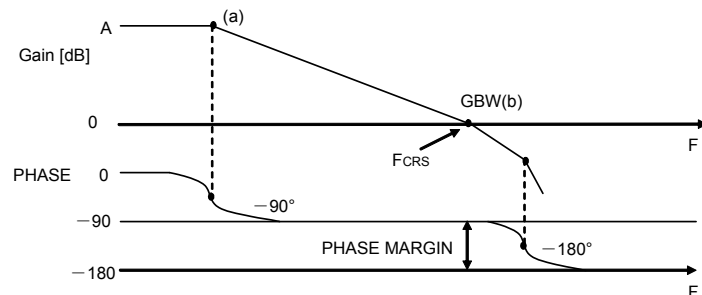

Figure 26.

● I/O equivalence circuit(s)

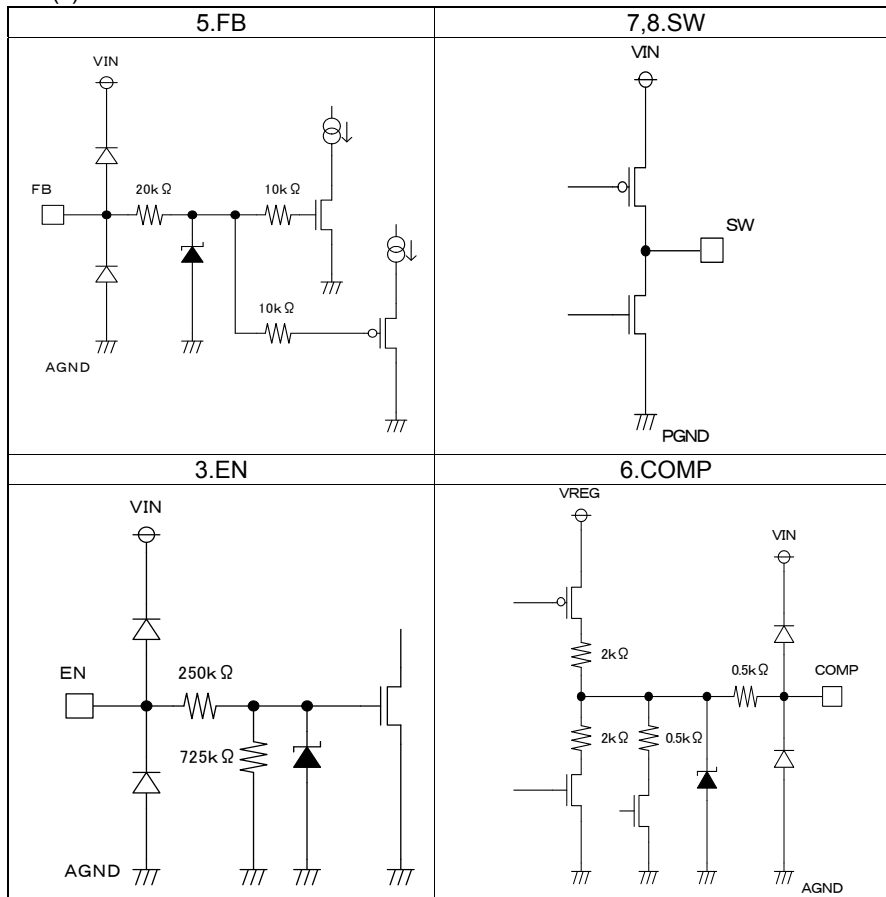

Figure 27.

●Notes for use

- 1) Absolute maximum ratings  
 Use of the IC in excess of absolute maximum ratings such as the applied voltage or operating temperature range may result in IC damage. Assumptions should not be made regarding the state of the IC (short mode or open mode) when such damage is suffered. A physical safety measure such as a fuse should be implemented when use of the IC in a special mode where the absolute maximum ratings may be exceeded is anticipated.
- 2) GND potential  
 Ensure a minimum GND pin potential in all operating conditions.
- 3) Setting of heat  
 Use a thermal design that allows for a sufficient margin in light of the power dissipation (Pd) in actual operating conditions.
- 4) Pin short and mistake fitting  
 Use caution when orienting and positioning the IC for mounting on printed circuit boards. Improper mounting may result in damage to the IC. Shorts between output pins or between output pins and the power supply and GND pins caused by the presence of a foreign object may result in damage to the IC.
- 5) Actions in strong magnetic field  
 Use caution when using the IC in the presence of a strong magnetic field as doing so may cause the IC to malfunction.
- 6) Testing on application boards  
 When testing the IC on an application board, connecting a capacitor to a pin with low impedance subjects the IC to stress. Always discharge capacitors after each process or step. Ground the IC during assembly steps as an antistatic measure, and use similar caution when transporting or storing the IC. Always turn the IC's power supply off before connecting it to or removing it from a jig or fixture during the inspection process.
- 7) Ground wiring patterns  
 When using both small signal and large current GND patterns, it is recommended to isolate the two ground patterns, placing a single ground point at the application's reference point so that the pattern wiring resistance and voltage variations caused by large currents do not cause variations in the small signal ground voltage. Be careful not to change the GND wiring patterns of any external components.
- 8) Regarding input pin of the IC  
 This monolithic IC contains P+ isolation and P substrate layers between adjacent elements in order to keep them isolated. P/N junctions are formed at the intersection of these P layers with the N layers of other elements to create a variety of parasitic elements.  
 For example, when the resistors and transistors are connected to the pins as shown in Figure 26. , a parasitic diode or a transistor operates by inverting the pin voltage and GND voltage.  
 The formation of parasitic elements as a result of the relationships of the potentials of different pins is an inevitable result of the IC's architecture. The operation of parasitic elements can cause interference with circuit operation as well as IC malfunction and damage. For these reasons, it is necessary to use caution so that the IC is not used in a way that will trigger the operation of parasitic elements such as by the application of voltages lower than the GND (P substrate) voltage to input and output pins.

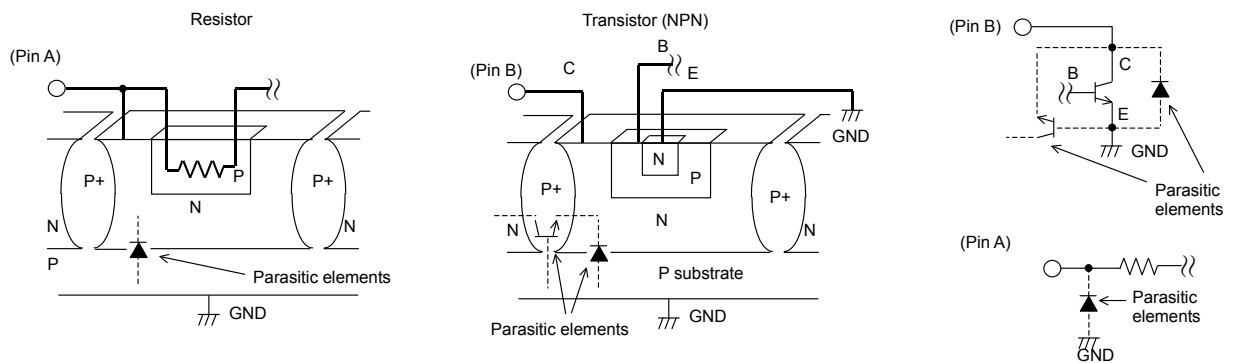

Figure 28. Example of a Simple Monolithic IC Architecture

## 9) Overcurrent protection circuits

An overcurrent protection circuit designed according to the output current is incorporated for the prevention of IC damage that may result in the event of load shorting. This protection circuit is effective in preventing damage due to sudden and unexpected accidents. However, the IC should not be used in applications characterized by the continuous operation or transitioning of the protection circuits. At the time of thermal designing, keep in mind that the current capacity has negative characteristics to temperatures.

## 10) Thermal shutdown circuit (TSD)

This IC incorporates a built-in TSD circuit for the protection from thermal destruction. The IC should be used within the specified power dissipation range. However, in the event that the IC continues to be operated in excess of its power dissipation limits, the attendant rise in the chip's junction temperature  $T_j$  will trigger the TSD circuit to turn off all output power elements. Operation of the TSD circuit presumes that the IC's absolute maximum ratings have been exceeded. Application designs should never make use of the TSD circuit.

## 11) EN control speed

Chattering happens if standing lowering speed is slow when standing of EN pin is lowered.

The reverse current in which the input side and the pressure operation are done from the output side is generated when chattering operates with the output voltage remained, and there is a case to destruction.

Please set to stand within 100 $\mu$ s when you control ON/OFF by the EN signal.

**Status of this document**

**The Japanese version of this document is formal specification. A customer may use this translation version only for a reference to help reading the formal version.**

**If there are any differences in translation version of this document formal version takes priority**

●Power Dissipation

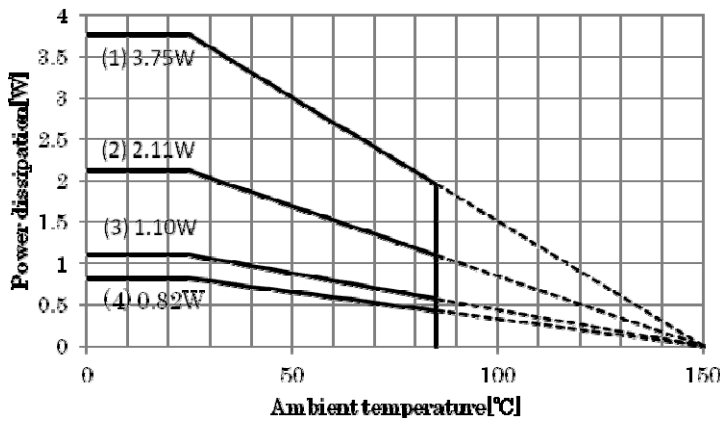

HTSOP-J8 Package

- On 70 × 70 × 1.6 mm glass epoxy PCB
- (1) 1-layer board (Backside copper foil area 0 mm × 0 mm)
- (2) 2-layer board (Backside copper foil area 15 mm × 15 mm)
- (3) 2-layer board (Backside copper foil area 70 mm × 70 mm)
- (4) 4-layer board (Backside copper foil area 70 mm × 70 mm)

●Ordering Information

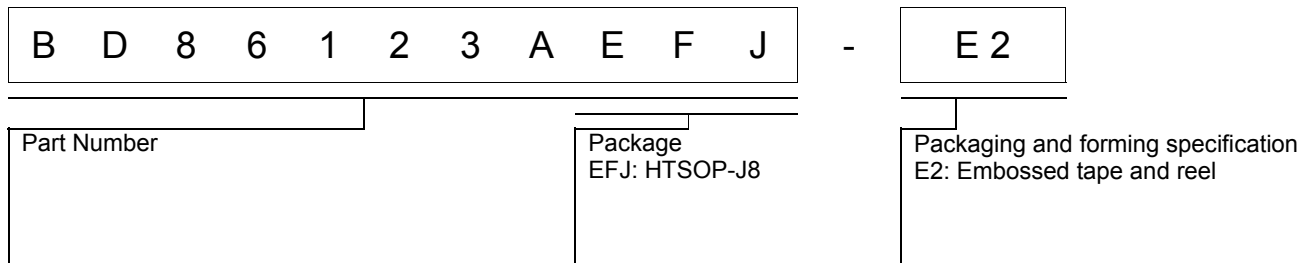

●Physical Dimension Tape and Reel Information

HTSOP-J8

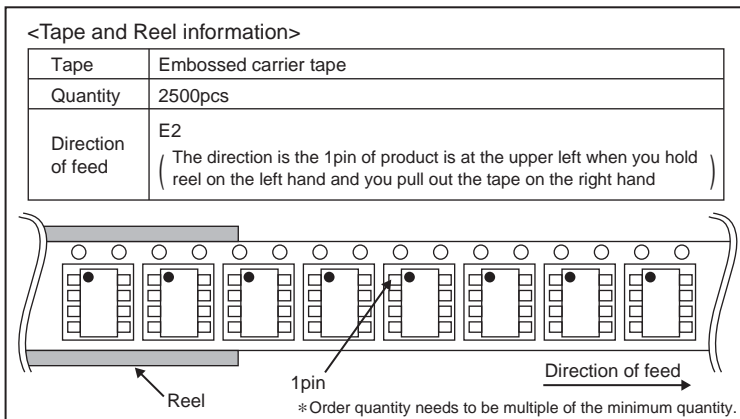
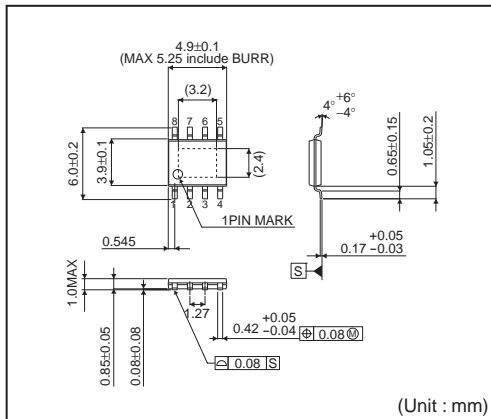

●Marking Diagram(s)(TOP VIEW)

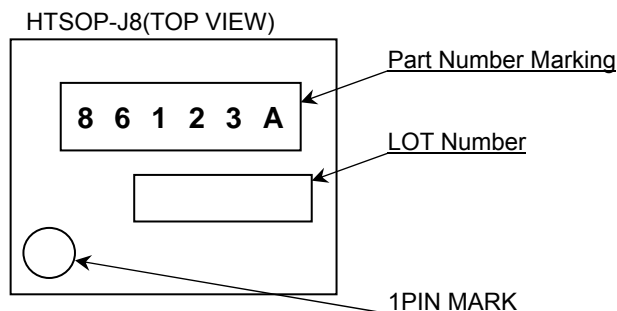

## ●History

Date	Revision	Changes
04.Sep.2012	001	New Release

## Looking for pricing, stock, or lifecycle information?

Click below to explore more details on WIN SOURCE:

- ⊖ [View BD86123AEFJ-E2 on WIN SOURCE](#)
- ⊖ [Rohm Semiconductor](#) Information

## Optimize Your Supply Chain with WIN SOURCE Solutions

- ✓ Global Sourcing Solution
- ✓ Obsolete Management
- ✓ Cost Control Management
- ✓ Shortage Management
- ✓ Alternative Solution
- ✓ Excess Inventory Management