



**THE DATASHEET OF
BD9B304QWZ-E2**



2.7V to 5.5V Input, 3.0A Integrated MOSFET Single Synchronous Buck DC/DC Converter

BD9B304QWZ

General Description

BD9B304QWZ is a synchronous buck switching regulator with built-in low on-resistance power MOSFETs. This IC, which is capable of providing current up to 3A, features fast transient response by employing constant on-time control system. It offers high oscillating frequency at low inductance. With its original constant on-time control method which operates low consumption at light load, this product is ideal for equipment and devices that demand minimal standby power consumption.

Features

- Single Synchronous Buck DC/DC Converter
- Constant On-time Control Suitable to Deep-SLLM
- Over Current Protection
- Short Circuit Protection
- Thermal Shutdown Protection
- Under Voltage Lockout Protection
- UMMP008AZ020 Package (Backside Heat Dissipation)

Applications

- Step-down Power Supply for DSPs, FPGAs, Microprocessors, etc.
- Laptop PCs/Tablet PCs/Servers
- LCD TVs
- Storage Devices (HDDs/SSDs)
- Printers, OA Equipment
- Distributed Power Supplies, Secondary Power Supplies

Key Specifications

- Input Voltage Range: 2.7V to 5.5V
- Output Voltage Range: 0.8 V to $V_{IN} \times 0.8$ V
- Output Current: 3A (Max)
- Switching Frequency: 2MHz/1MHz (Typ)
- High-Side MOSFET ON Resistance: 40mΩ (Typ)
- Low-Side MOSFET ON Resistance: 40mΩ (Typ)
- Standby Current: 0μA (Typ)

Package

UMMP008AZ020 W (Typ) x D (Typ) x H (Max)
2.00mm x 2.00mm x 0.40mm

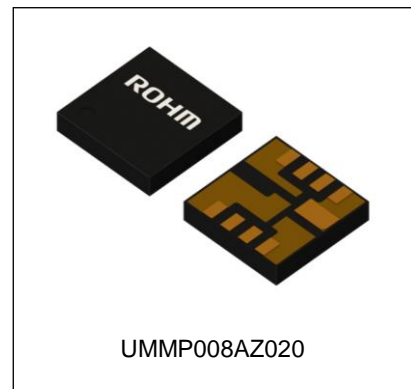

Typical Application Circuit

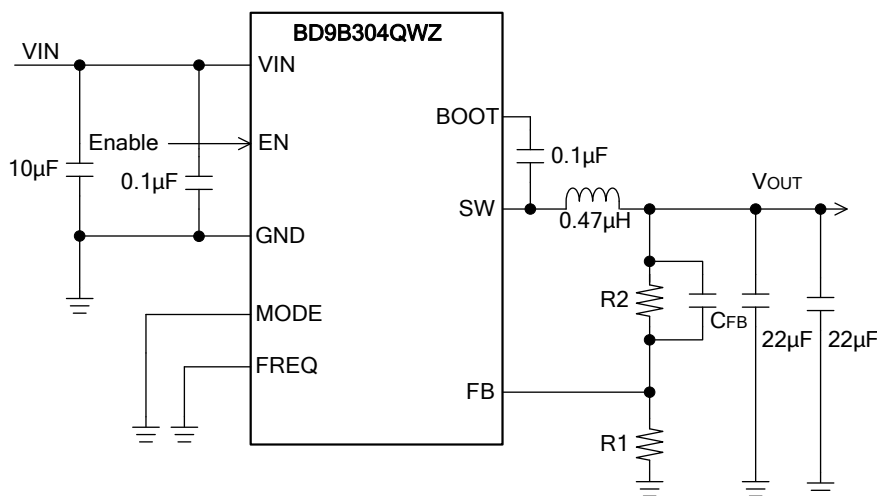

Figure 1. Application Circuit(MODE=L, FREQ=L)

Pin Configuration

(TOP VIEW)

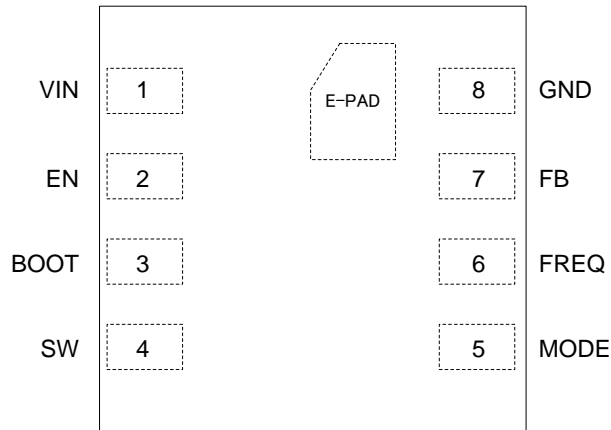

Figure 2. Pin Configuration

Pin Descriptions

Pin No.	Pin Name	Function
1	VIN	Power supply terminal for the switching regulator. This terminal supply power to the output stage and control circuit of the switching regulator. Connecting 0.1 μ F and 10 μ F ceramic capacitors are recommended.
2	EN	Enable terminal. Turning this terminal signal Low (0.8V or lower) forces the device to enter the shutdown mode. Turning this terminal signal High (2.0V or higher) enables the device. This terminal must be terminated.
3	BOOT	Terminal for bootstrap. Connect a bootstrap capacitor of 0.1 μ F between this terminal and SW terminal. The voltage of this terminal is the gate drive voltage of the High-Side MOSFET.
4	SW	Switch node. This terminal is connected to the source of the High-Side MOSFET and drain of the Low-Side MOSFET. Connect a bootstrap capacitor of 0.1 μ F between this terminal and BOOT terminal. In addition, connect an inductor considering the direct current superimposition characteristic. Use an inductor of 0.47 μ H at FREQ=L or 1.0 μ H at FREQ=H.
5	MODE	Terminal for setting switching control mode. Connecting this terminal to VIN forces the device to operate in the fixed frequency PWM mode. Connecting this terminal to ground enables the Deep-SLLM control and the mode is automatically switched between the Deep-SLLM control and fixed frequency PWM mode. Please fix this terminal to VIN or ground.
6	FREQ	Terminal for setting switching frequency. Connecting this terminal to ground makes switching to operate constant on-time corresponding to 2MHz. Connecting this terminal to VIN makes switching to operate constant on-time corresponding to 1MHz. Please fix this terminal to VIN or ground.
7	FB	An inverting input node for the error amplifier and main comparator. See page 21 for how to calculate the resistance of the output voltage setting.
8	GND	Ground terminal for the output stage of the switching regulator and the control circuit.
-	E-Pad	A backside heat dissipation exposed pad. Connecting to the internal PCB ground plane by using multiple vias provides excellent heat dissipation characteristics.

Block Diagram

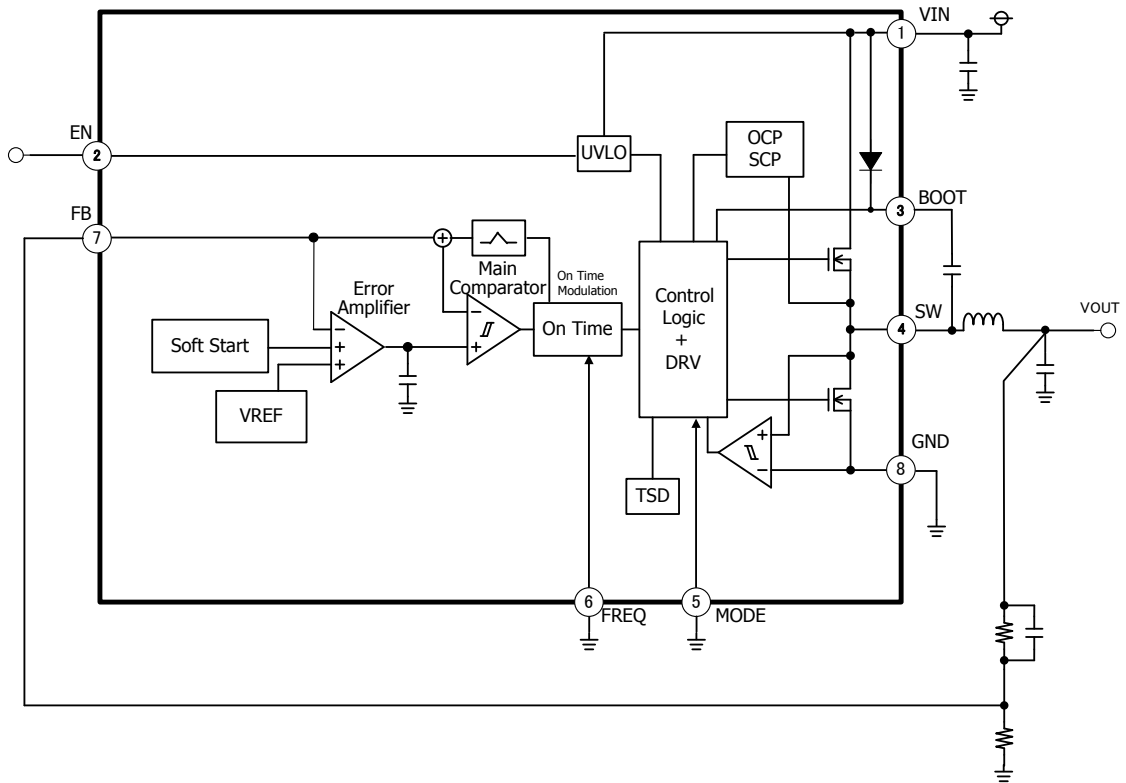

Figure 3. Block Diagram

Description of Blocks

- **VREF**
The VREF block generates the internal reference voltage.
- **UVLO**
The UVLO block is for under voltage lockout protection. It will shut down the IC when VIN falls to 2.45 V (Typ) or lower. The threshold voltage has a hysteresis of 100mV (Typ).
- **TSD**
The TSD block is for thermal protection. The thermal protection circuit shuts down the device when the internal temperature of IC rises to 175°C (Typ) or higher. Thermal protection circuit resets when the temperature falls. The circuit has a hysteresis of 25°C (Typ).
- **Soft Start**
The Soft Start circuit slows down the rise of output voltage during start-up and controls the current, which allows the prevention of output voltage overshoot and inrush current. The internal soft start time is set to 1ms typically.
- **Control Logic + DRV**
This block is a DC/DC driver. A signal from On Time block is applied to drive the MOSFETs.
- **OCP/SCP**
After soft start is completed and in condition where output voltage is below 70% (Typ) of voltage setting, it counts the number of times of which current flowing in High side FET reaches over current limit. When 512 times is counted, it stops operation for 1ms (Typ) and re-operates. Counting is reset when output voltage is above 80% (Typ) of voltage setting or when IC re-operates by EN, UVLO, SCP function.
- **Error Amplifier**
Error Amplifier adjusts Main Comparator input to make internal reference voltage equal to FB terminal voltage.
- **Main Comparator**
Main comparator compares Error Amplifier output and FB terminal voltage. When FB terminal voltage becomes low, it outputs High and reports to the On Time block that the output voltage has dropped below control voltage.
- **On Time**
This is a block which creates On Time. Requested On Time is created when Main Comparator output becomes High. On Time is adjusted to restrict frequency change even with I/O voltage change.

Absolute Maximum Ratings (Ta = 25°C)

Parameter	Symbol	Rating	Unit
Input Voltage	V _{IN}	-0.3 to +7	V
EN Terminal Voltage	V _{EN}	-0.3 to +7	V
MODE Terminal Voltage	V _{MODE}	-0.3 to +7	V
FREQ Terminal Voltage	V _{FREQ}	-0.3 to +7	V
Voltage from GND to BOOT	V _{BOOT}	-0.3 to +14	V
Voltage from SW to BOOT	ΔV _{BOOT}	-0.3 to +7	V
FB Terminal Voltage	V _{FB}	-0.3 to +7	V
SW Terminal Voltage	V _{SW}	-0.3 to V _{IN} + 0.3	V
Output Current	I _{OUT}	3.5	A
Maximum Junction Temperature	T _{jmax}	150	°C
Storage Temperature Range	T _{stg}	-55 to +150	°C

Caution 1: Operating the IC over the absolute maximum ratings may damage the IC. The damage can either be a short circuit between pins or an open circuit between pins and the internal circuitry. Therefore, it is important to consider circuit protection measures, such as adding a fuse, in case the IC is operated over the absolute maximum ratings.

Caution 2: Should by any chance the maximum junction temperature rating be exceeded the rise in temperature of the chip may result in deterioration of the properties of the chip. In case of exceeding this absolute maximum rating, increase the board size and copper area to prevent exceeding the maximum junction temperature rating.

Thermal Resistance^(Note 1)

Parameter	Symbol	Thermal Resistance (Typ)		Unit
		1s ^(Note 3)	2s2p ^(Note 4)	
UMMP008AZ020				
Junction to Ambient	θ _{JA}	376.0	67.8	°C/W
Junction to Top Characterization Parameter ^(Note 2)	Ψ _{JT}	92.0	18.0	°C/W

(Note 1) Based on JESD51-2A(Still-Air)

(Note 2) The thermal characterization parameter to report the difference between junction temperature and the temperature at the top center of the outside surface of the component package.

(Note 3) Using a PCB board based on JESD51-3.

Layer Number of Measurement Board	Material	Board Size
Single	FR-4	114.3mm x 76.2mm x 1.57mmt

Top	
Copper Pattern	Thickness
Footprints and Traces	70μm

(Note 4) Using a PCB board based on JESD51-5, 7.

Layer Number of Measurement Board	Material	Board Size	Thermal Via ^(Note 5)	
			Pitch	Diameter
4 Layers	FR-4	114.3mm x 76.2mm x 1.6mmt	-	Φ0.30mm

Top		2 Internal Layers		Bottom	
Copper Pattern	Thickness	Copper Pattern	Thickness	Copper Pattern	Thickness
Footprints and Traces	70μm	74.2mm x 74.2mm	35μm	74.2mm x 74.2mm	70μm

(Note 5) This thermal via connects with the copper pattern of all layers.

Recommended Operating Conditions

Parameter	Symbol	Min	Typ	Max	Unit
Input Voltage	V_{IN}	2.7	-	5.5	V
Operating Temperature Range	T_{opr}	-40	-	+85	°C
Output Current	I_{OUT}	0	-	3	A
Output Voltage Range	V_{RANGE}	0.8	-	$V_{IN} \times 0.8$	V

Electrical Characteristics (Unless otherwise specified $T_a=25^\circ\text{C}$, $V_{IN}=5\text{V}$, $V_{EN}=5\text{V}$, $V_{MODE}=GND$)

Parameter	Symbol	Min	Typ	Max	Unit	Conditions
VIN Pin						
Standby Supply Current	I_{STB}	-	0	10	μA	$V_{EN}=GND$
Operating Supply Current	I_{CC}	-	40	60	μA	$V_{FREQ}=V_{IN}$, $I_{OUT}=0\text{mA}$ Non switching
UVLO Detection Threshold Voltage	V_{UVLO1}	2.35	2.45	2.55	V	VIN falling
UVLO Release Threshold Voltage	V_{UVLO2}	2.425	2.55	2.7	V	VIN rising
UVLO Hysteresis	$V_{UVLOHYS}$	50	100	200	mV	
Enable						
EN Input High Level Voltage	V_{ENH}	2.0	-	V_{IN}	V	
EN Input Low Level Voltage	V_{ENL}	GND	-	0.8	V	
EN Input Current	I_{EN}	-	5	10	μA	$V_{EN}=5\text{V}$
Reference Voltage, Error Amplifier						
FB Terminal Voltage	V_{FB}	0.792	0.8	0.808	V	
FB Input Current	I_{FB}	-	-	1	μA	$V_{FB}=0.8\text{V}$
Soft Start Time	t_{SS}	0.5	1.0	2.0	ms	
Control						
FREQ Input High Level Voltage	V_{FRQH}	$V_{IN}-0.3$	-	V_{IN}	V	
FREQ Input Low Level Voltage	V_{FRQL}	GND	-	0.3	V	
MODE Input High Level Voltage	V_{MODEH}	$V_{IN}-0.3$	-	V_{IN}	V	
MODE Input Low Level Voltage	V_{MODEL}	GND	-	0.3	V	
On Time1	t_{ONT1}	96	120	144	ns	$V_{OUT}=1.2\text{V}$, $V_{FREQ}=GND$, $V_{MODE}=V_{IN}$
On Time2	t_{ONT2}	192	240	288	ns	$V_{OUT}=1.2\text{V}$, $V_{FREQ}=V_{IN}$, $V_{MODE}=V_{IN}$
SW						
High Side FET On Resistance	R_{ONH}	-	40	80	m Ω	$V_{BOOT} - V_{SW}=5\text{V}$
Low Side FET On Resistance	R_{ONL}	-	40	80	m Ω	
High Side Output Leakage Current	I_{LH}	-	0	10	μA	No switching
Low Side Output Leakage Current	I_{LL}	-	0	10	μA	No switching

Typical Performance Curves

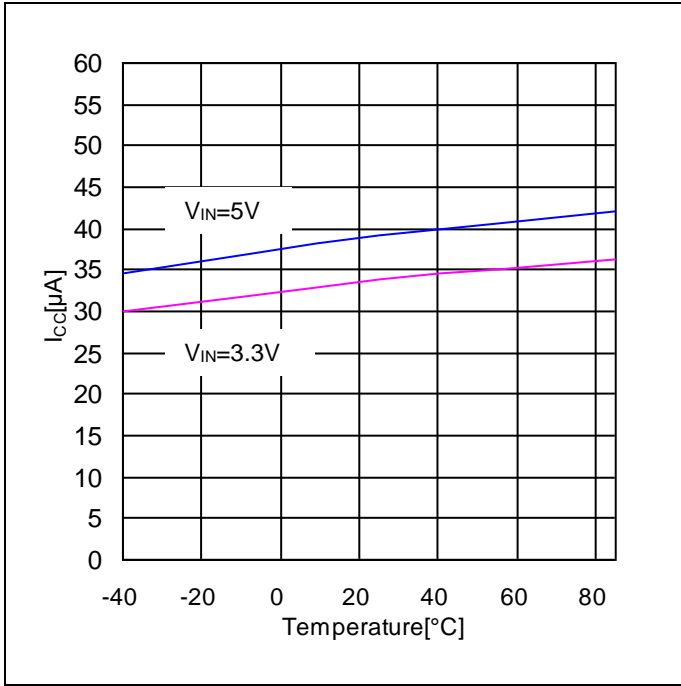

Figure 4. Operating Supply Current vs Temperature

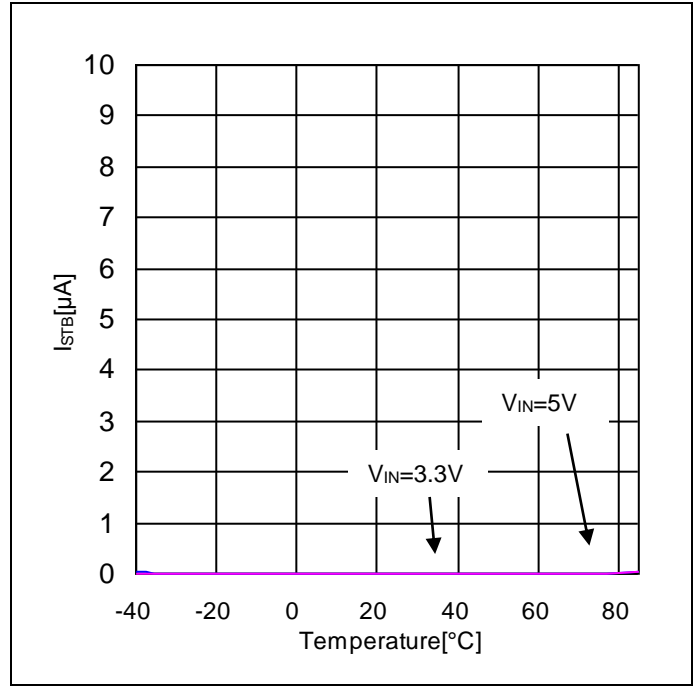

Figure 5. Standby Supply Current vs Temperature

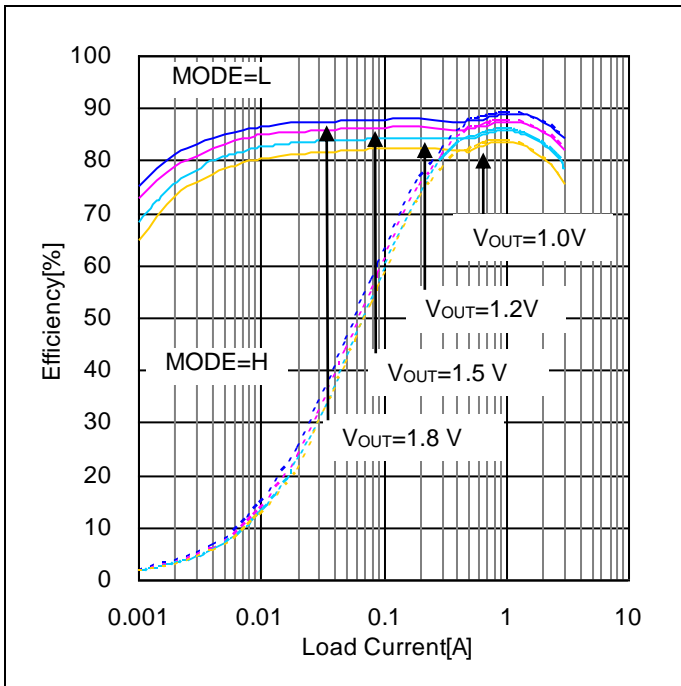

Figure 6. Efficiency vs Load Current
(VIN=5V, L=0.47µH, FREQ=L)

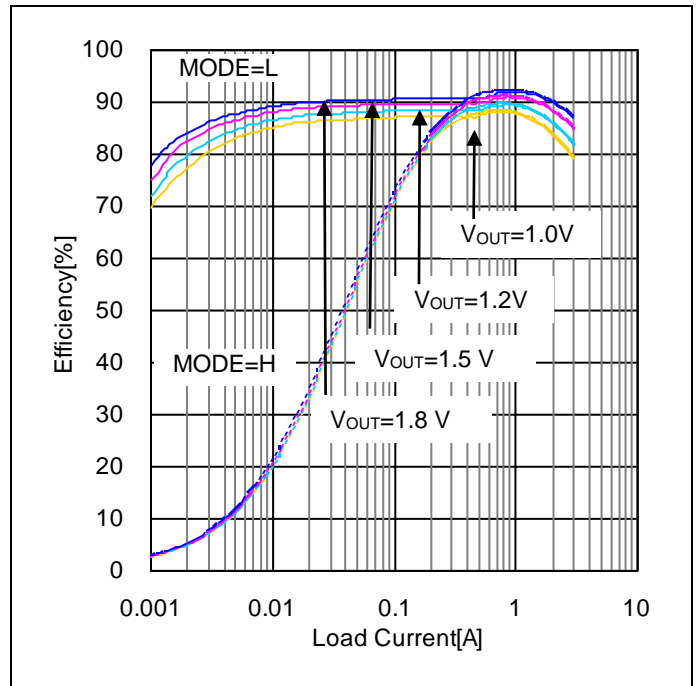

Figure 7. Efficiency vs Load Current
(VIN=5V, L=1.0µH, FREQ=H)

Typical Performance Curves - continued

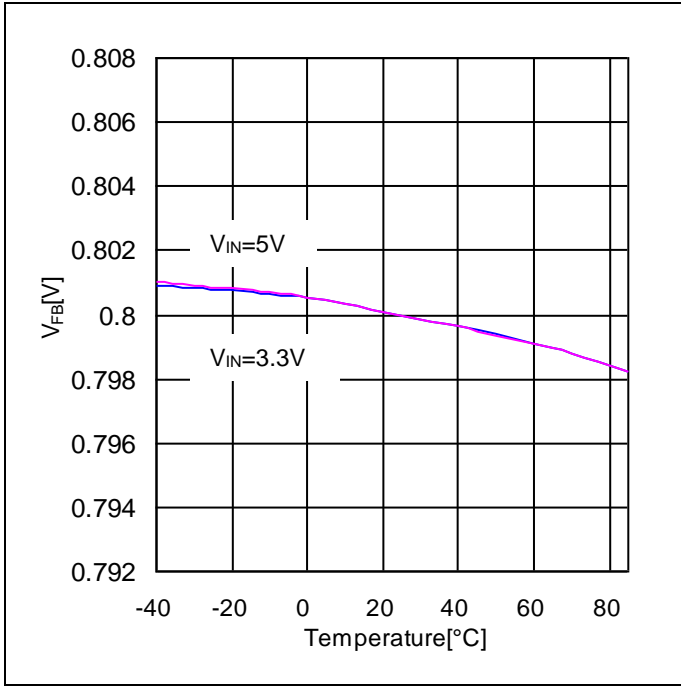

Figure 8. FB Terminal Voltage vs Temperature

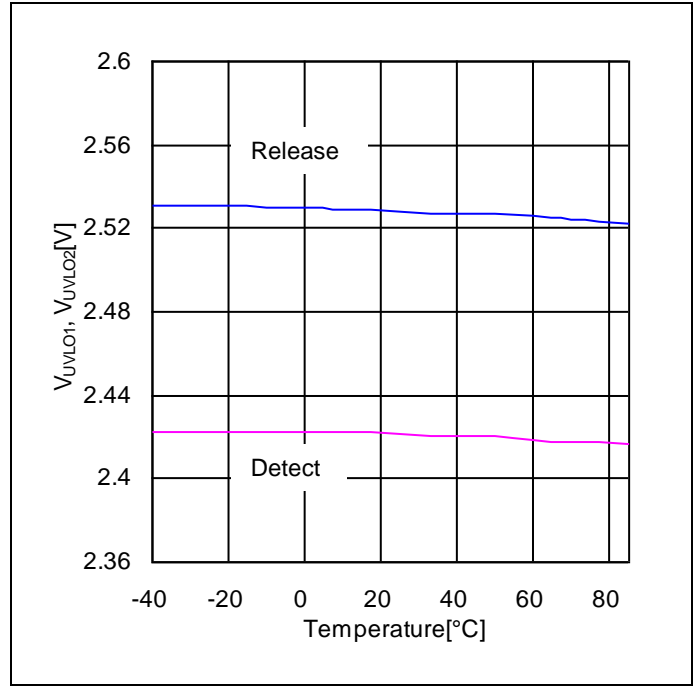

Figure 9. UVLO Detection Threshold Voltage, UVLO Release Threshold Voltage vs Temperature

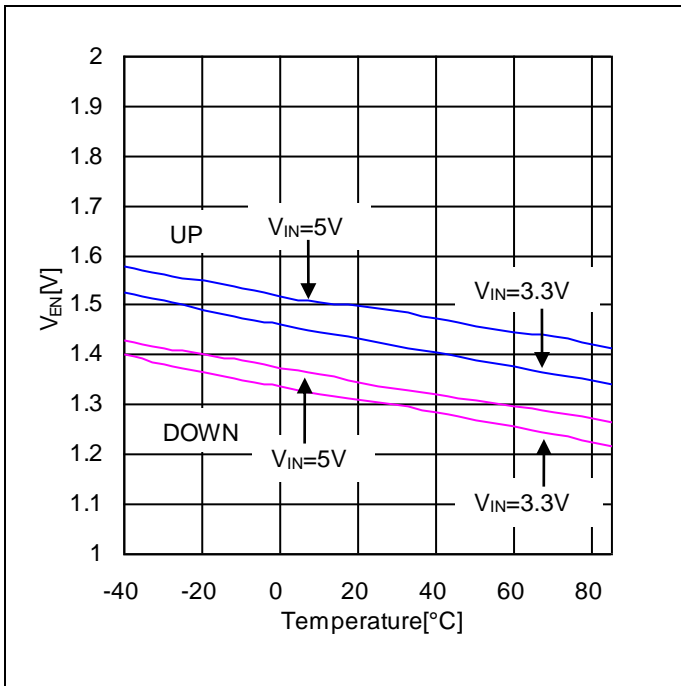

Figure 10. EN Threshold Voltage vs Temperature

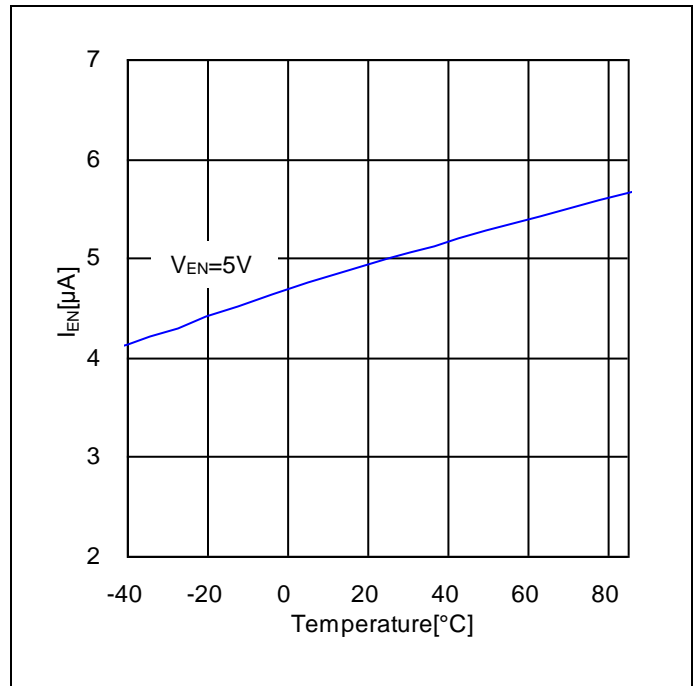

Figure 11. EN Input Current vs Temperature

Typical Performance Curves - continued

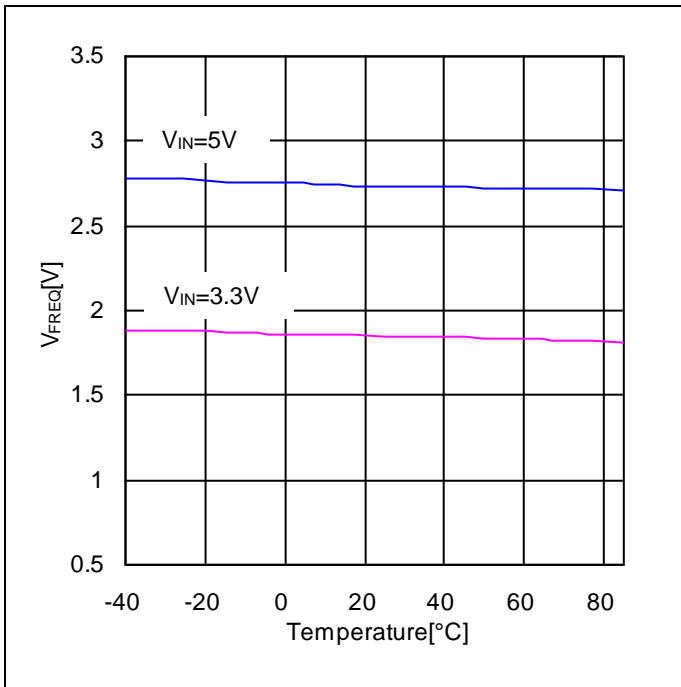

Figure 12. FREQ Threshold Voltage vs Temperature

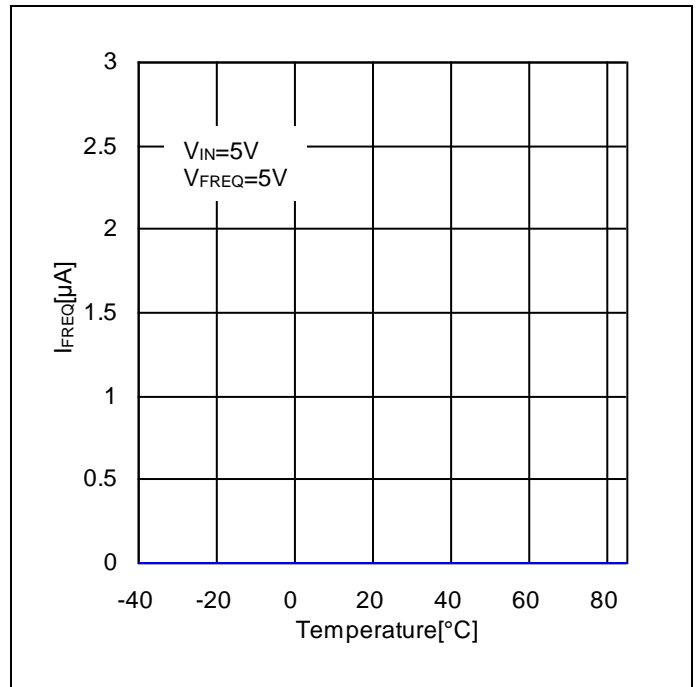

Figure 13. FREQ Input Current vs Temperature

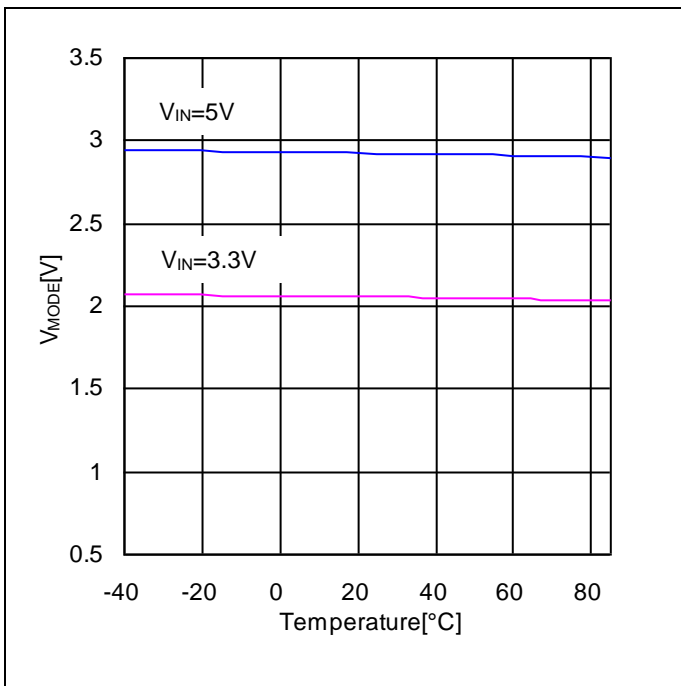

Figure 14. MODE Threshold Voltage vs Temperature

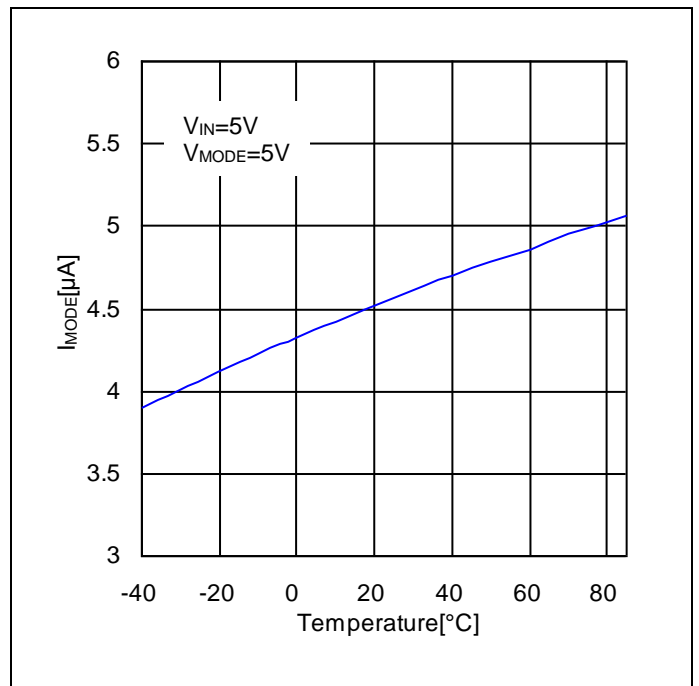

Figure 15. MODE Input Current vs Temperature

Typical Performance Curves - continued

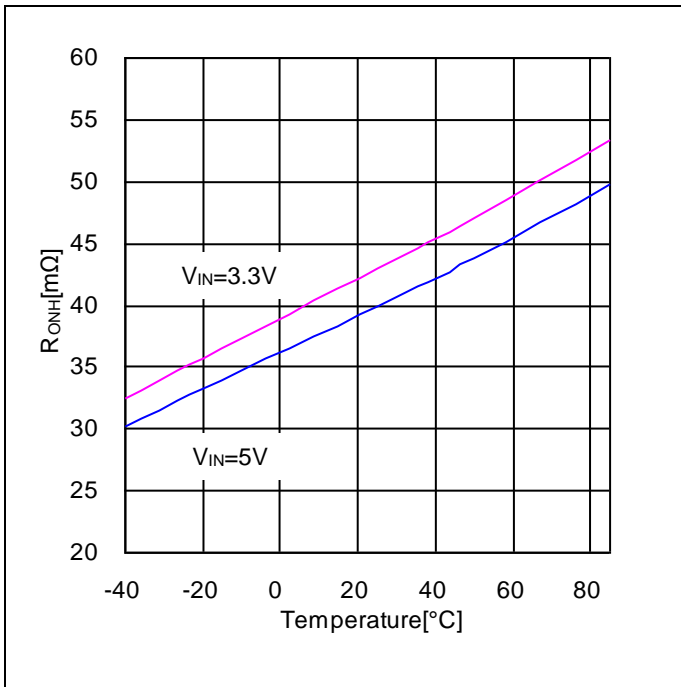

Figure 16. High Side FET On Resistance vs Temperature

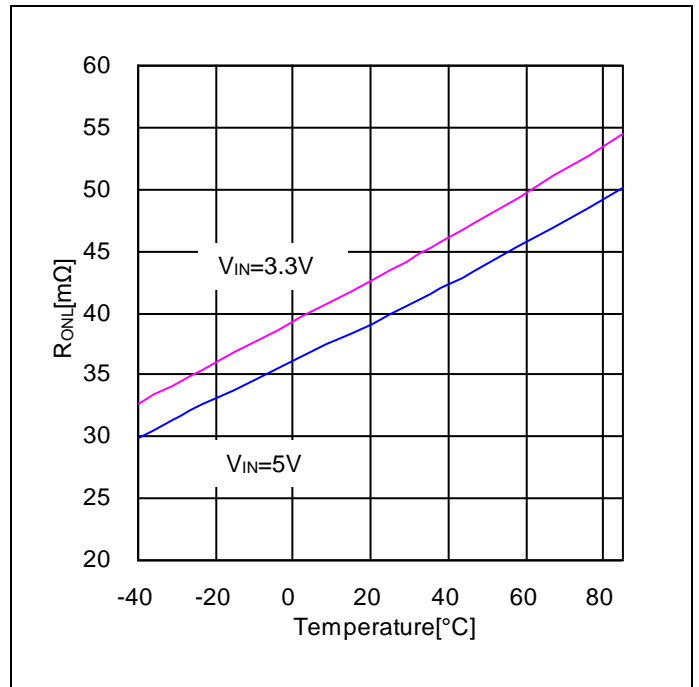

Figure 17. Low Side FET On Resistance vs Temperature

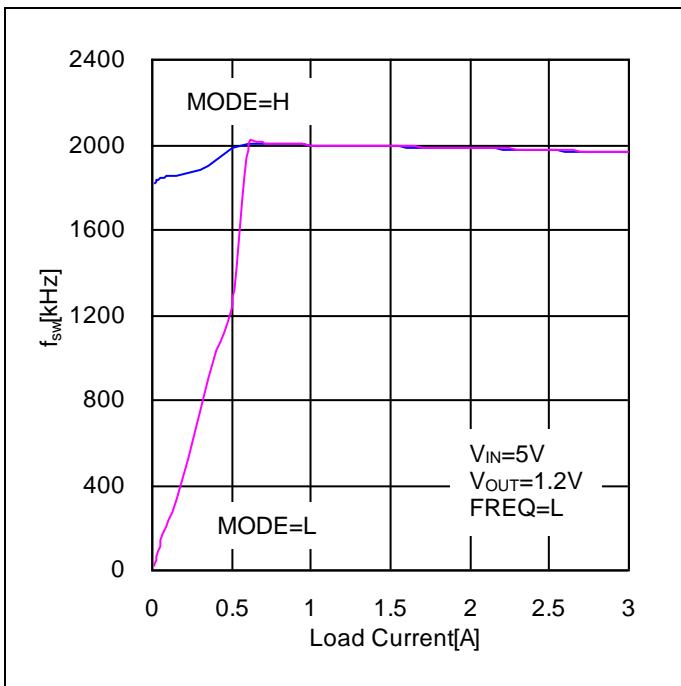

Figure 18. Switching Frequency vs Load Current

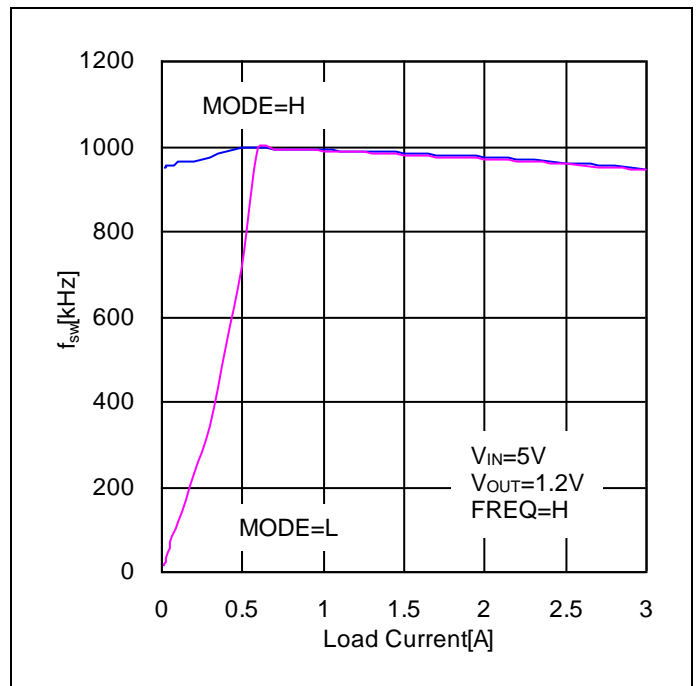

Figure 19. Switching Frequency vs Load Current

Typical Performance Curves - continued

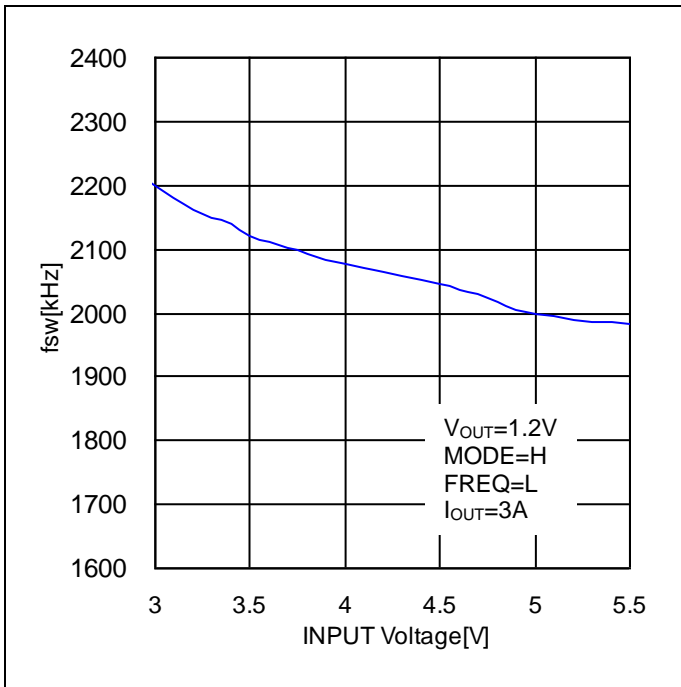

Figure 20. Switching Frequency vs Input Voltage

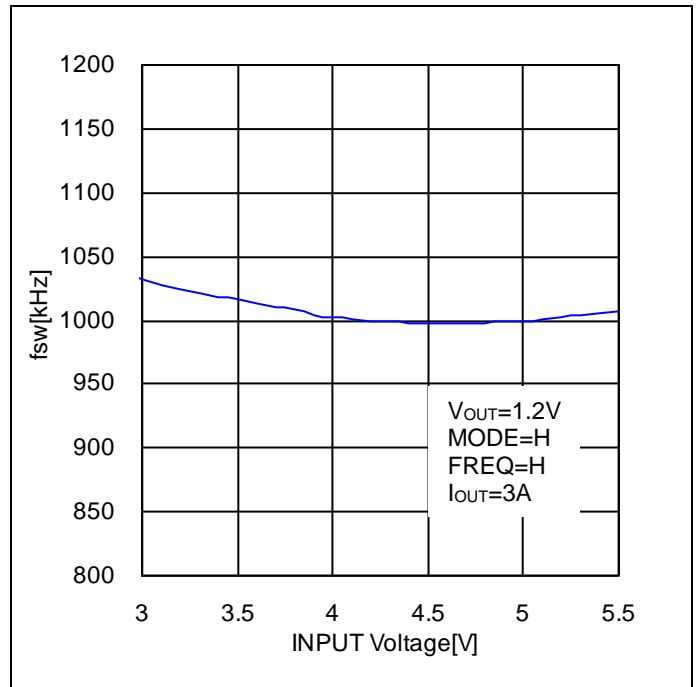

Figure 21. Switching Frequency vs Input Voltage

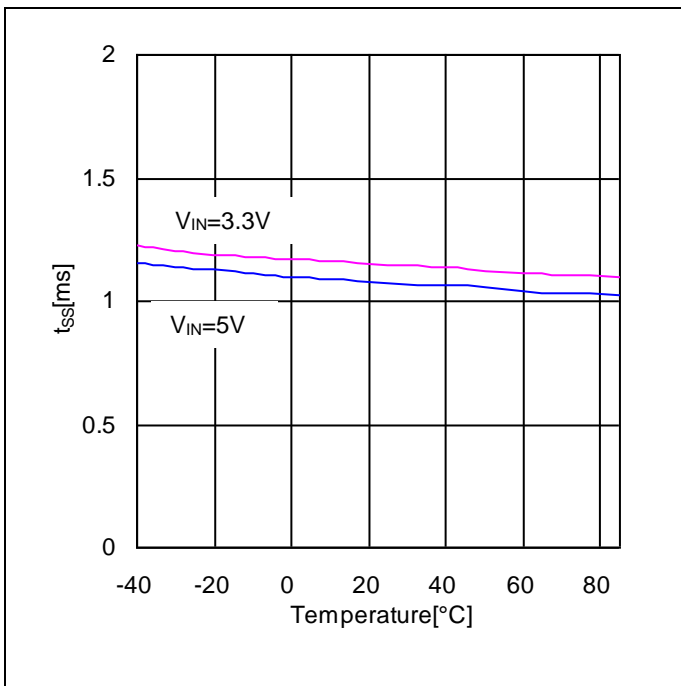

Figure 22. Soft Start Time vs Temperature

Typical Performance Curves - continued

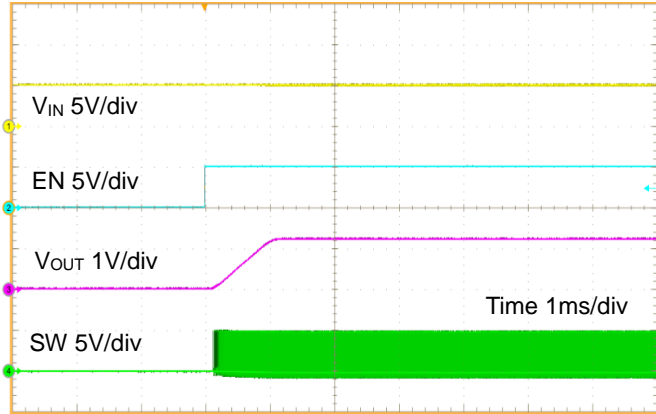

Figure 23. Power ON Waveform (EN=0V to 5V)
($V_{OUT}=1.2V$, FREQ=H, $R_{LOAD}=0.4\Omega$)

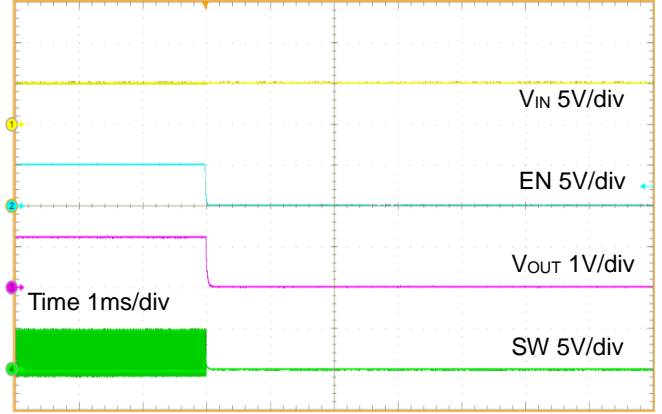

Figure 24. Power OFF Waveform (EN=5V to 0V)
($V_{OUT}=1.2V$, FREQ=H, $R_{LOAD}=0.4\Omega$)

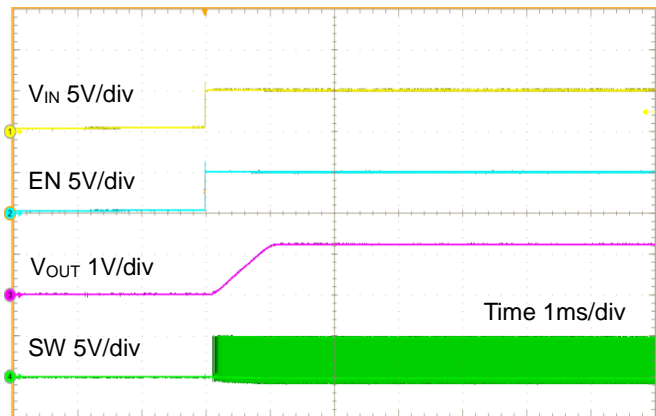

Figure 25. Power ON Waveform ($V_{IN} = EN$)
($V_{OUT}=1.2V$, FREQ=H, $R_{LOAD}=0.4\Omega$)

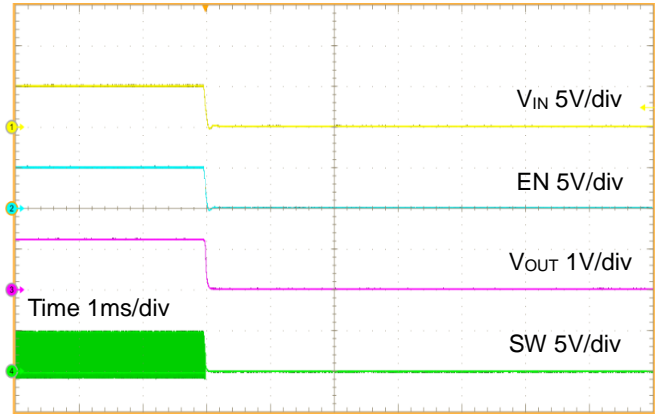

Figure 26. Power OFF Waveform ($V_{IN} = EN$)
($V_{OUT}=1.2V$, FREQ=H, $R_{LOAD}=0.4\Omega$)

Typical Performance Curves - continued

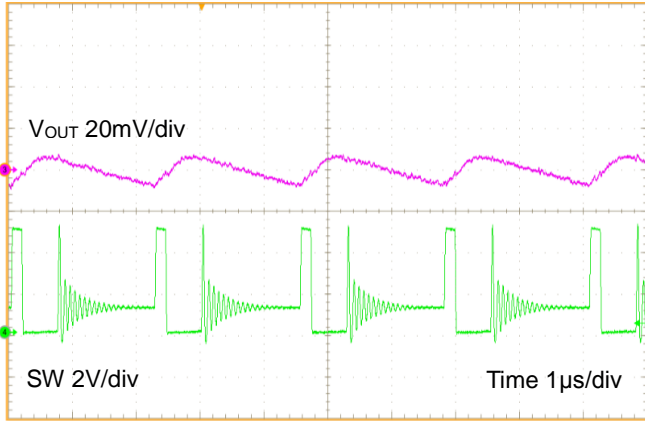

Figure 27. Switching Waveform
($V_{IN}=5V$, $V_{OUT}=1.2V$, $FREQ=L$, $I_{OUT}=0.2A$)

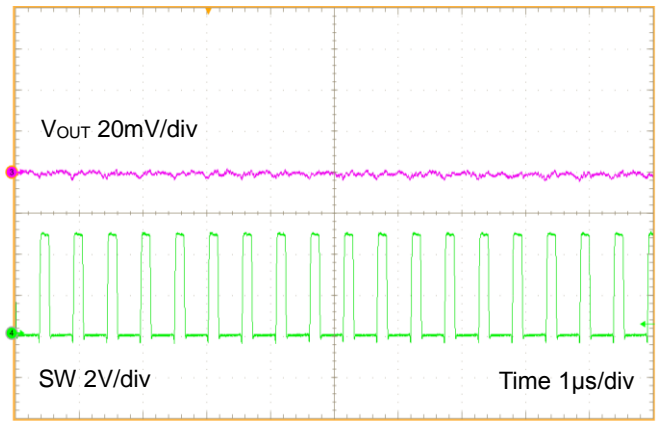

Figure 28. Switching Waveform
($V_{IN}=5V$, $V_{OUT}=1.2V$, $FREQ=L$, $I_{OUT}=3A$)

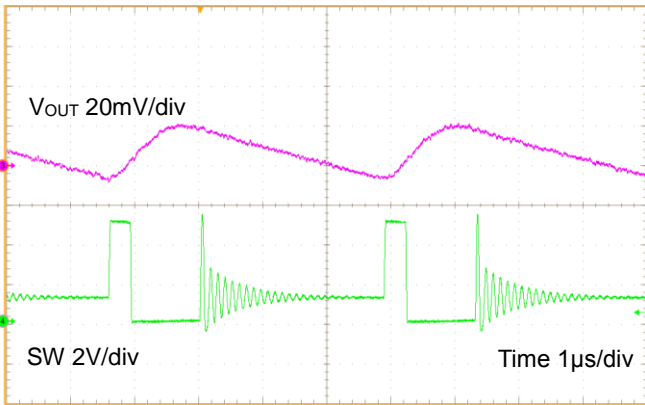

Figure 29. Switching Waveform
($V_{IN}=5V$, $V_{OUT}=1.2V$, $FREQ=H$, $I_{OUT}=0.2A$)

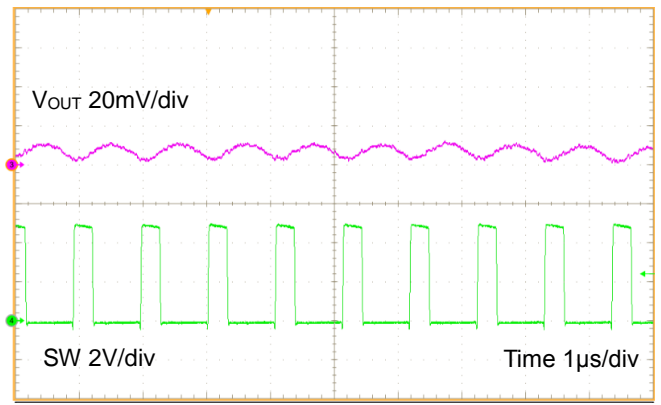

Figure 30. Switching Waveform
($V_{IN}=5V$, $V_{OUT}=1.2V$, $FREQ=H$, $I_{OUT}=3A$)

Typical Performance Curves - continued

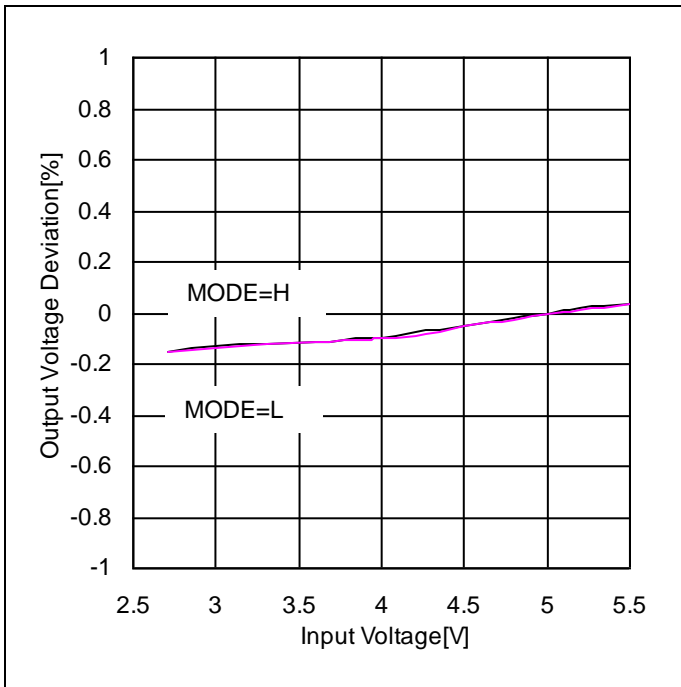

Figure 31. Line Regulation
($V_{OUT}=1.2V$, $L=1.0\mu H$, $FREQ=H$)

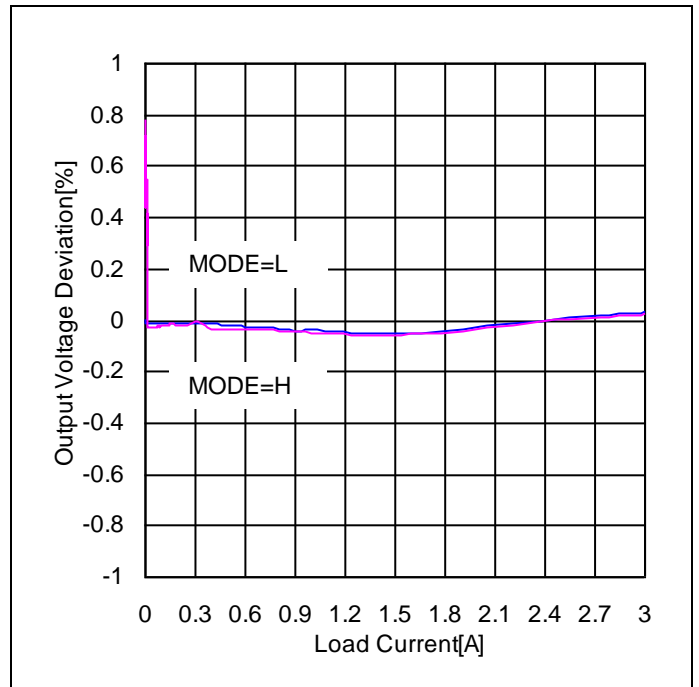

Figure 32. Load Regulation
($V_{IN}=5V$, $V_{OUT}=1.2V$, $L=1.0\mu H$, $FREQ=H$)

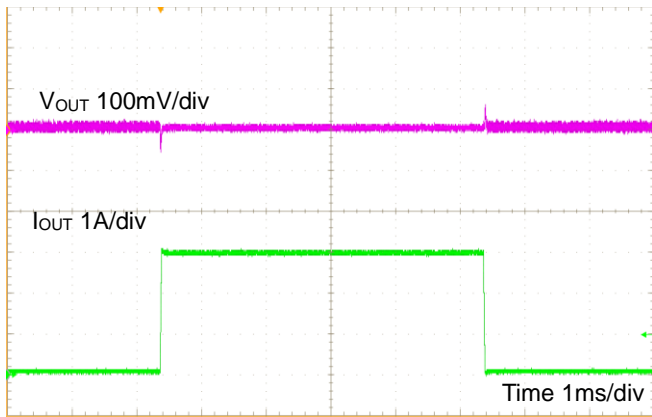

Figure 33. Load Transient Response $I_{OUT}=0.1A-3A$
($V_{IN}=5V$, $V_{OUT}=1.2V$, $FREQ=L$, $MODE=L$, $C_{OUT}=22\mu F \times 2$)

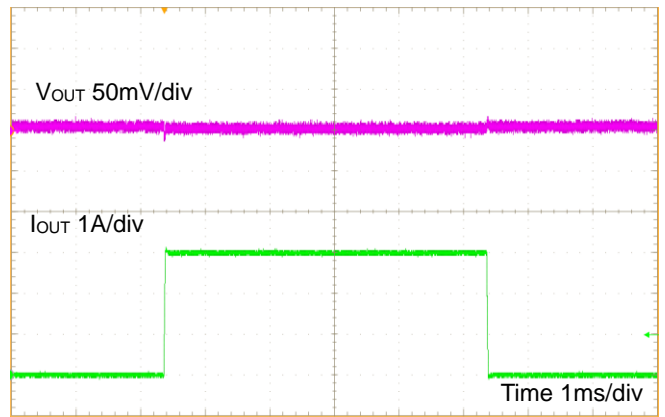

Figure 34. Load Transient Response $I_{OUT}=0A-3A$
($V_{IN}=5V$, $V_{OUT}=1.2V$, $FREQ=L$, $MODE=H$, $C_{OUT}=22\mu F \times 2$)

Function Explanations

1. Basic Operation

(1) DC/DC Converter operation

BD9B304QWZ is a synchronous rectifying step-down switching regulator that achieves faster load transient response by employing constant on-time control system. It utilizes switching operation in PWM (Pulse Width Modulation) mode for heavier load, while it utilizes Deep-SLLM (Simple Light Load Mode) control for lighter load to improve efficiency.

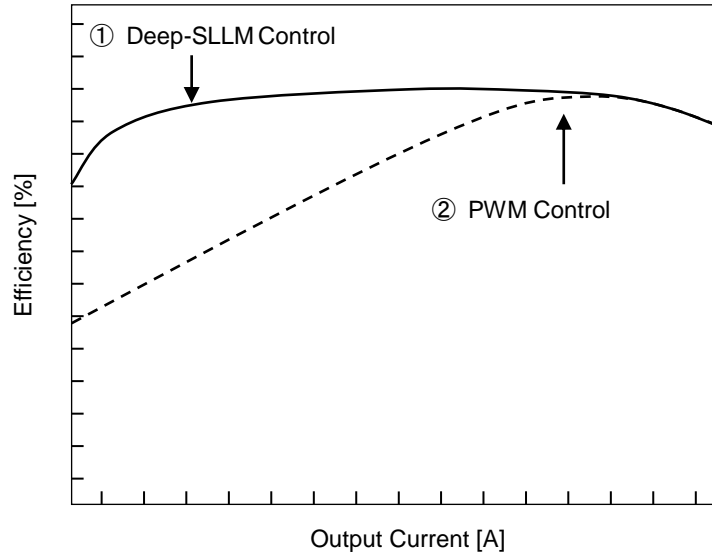

Figure 35. Efficiency (Deep-SLLM Control and PWM Control)

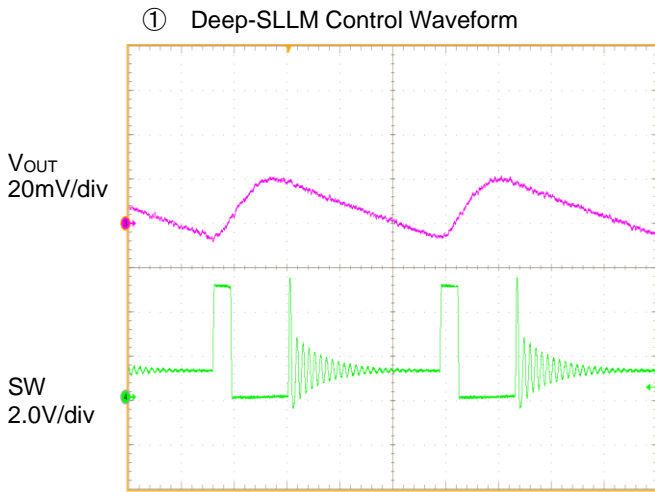

Figure 36. Switching Waveform at Deep-SLLM Control (VIN=5.0V, VOUT=1.2V, IOUT=200mA, FREQ=H)

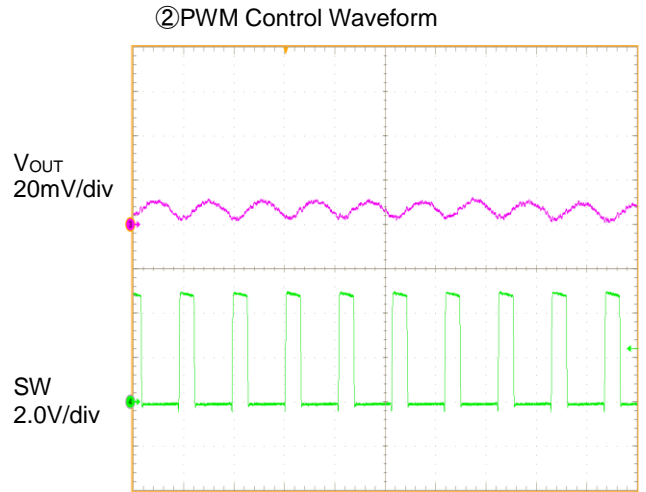

Figure 37. Switching Waveform at PWM Control (VIN=5.0V, VOUT=1.2V, IOUT=3A, FREQ=H)

(2) Enable Control

The IC shutdown can be controlled by the voltage applied to the EN terminal. When V_{EN} reaches 2.0 V(Min), the internal circuit is activated and the IC starts up. To enable shutdown control with the EN terminal, the shutdown interval (Low level interval of EN) must be set to 100 μ s or longer. Startup by EN must be at the same time or after the input of power supply voltage.

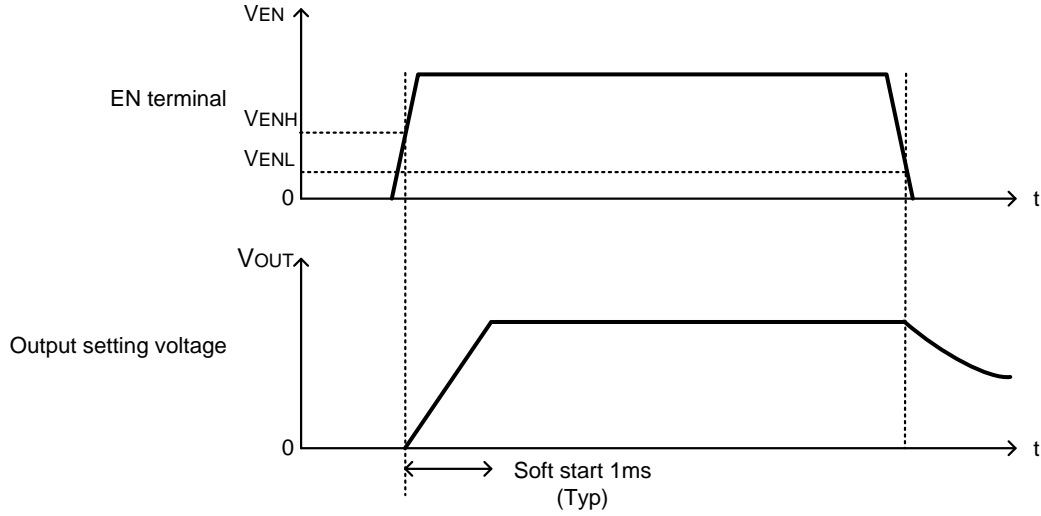

Figure 38. Start Up and Shut Down with Enable

(3) Soft Start

When EN terminal is turned High, Soft Start operates and output voltage gradually rises. With the Soft Start Function, over shoot of output voltage and rush current can be prevented. Rising time of output voltage is 1ms(Typ).

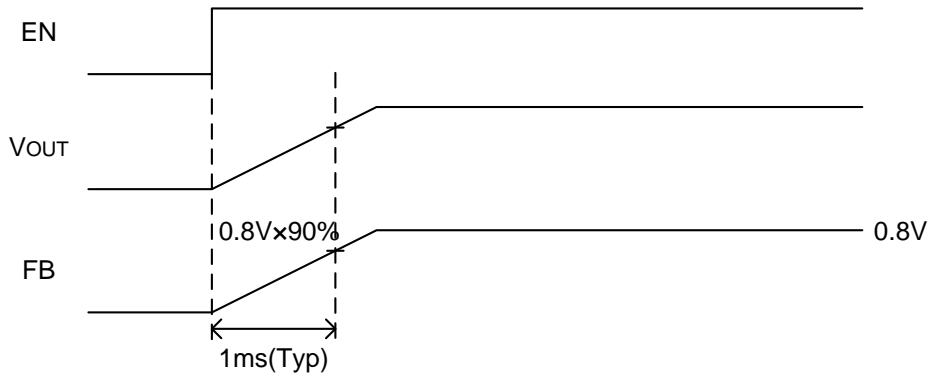

Figure 39. Soft Start Timing Chart

2. Protection

The protective circuits are intended for prevention of damage caused by unexpected accidents. Do not use them for continuous protective operation.

(1) Over Current Protection (OCP) / Short Circuit Protection (SCP)

Setting of Over current protection is 5.5A (Typ). When OCP is triggered, over current protection is realized by restricting On / Off Duty of current flowing in upper MOSFET by each switching cycle. Also, if Over current protection operates 512 cycles in a condition where FB terminal voltage reaches below 70% of internal reference voltage, Short Circuit protection (SCP) operates and stops switching for 1ms(Typ) before it initiates restart. However, during startup, Short circuit protection will not operate even if the IC is still in the SCP condition.

Table 1. Over Current Protection / Short Circuit Protection Function

EN terminal	Startup	Over current protection	Short circuit protection
More than 2.0V	While start up	Valid	Invalid
	Startup completed	Valid	Valid
Less than 0.8V	*	Invalid	Invalid

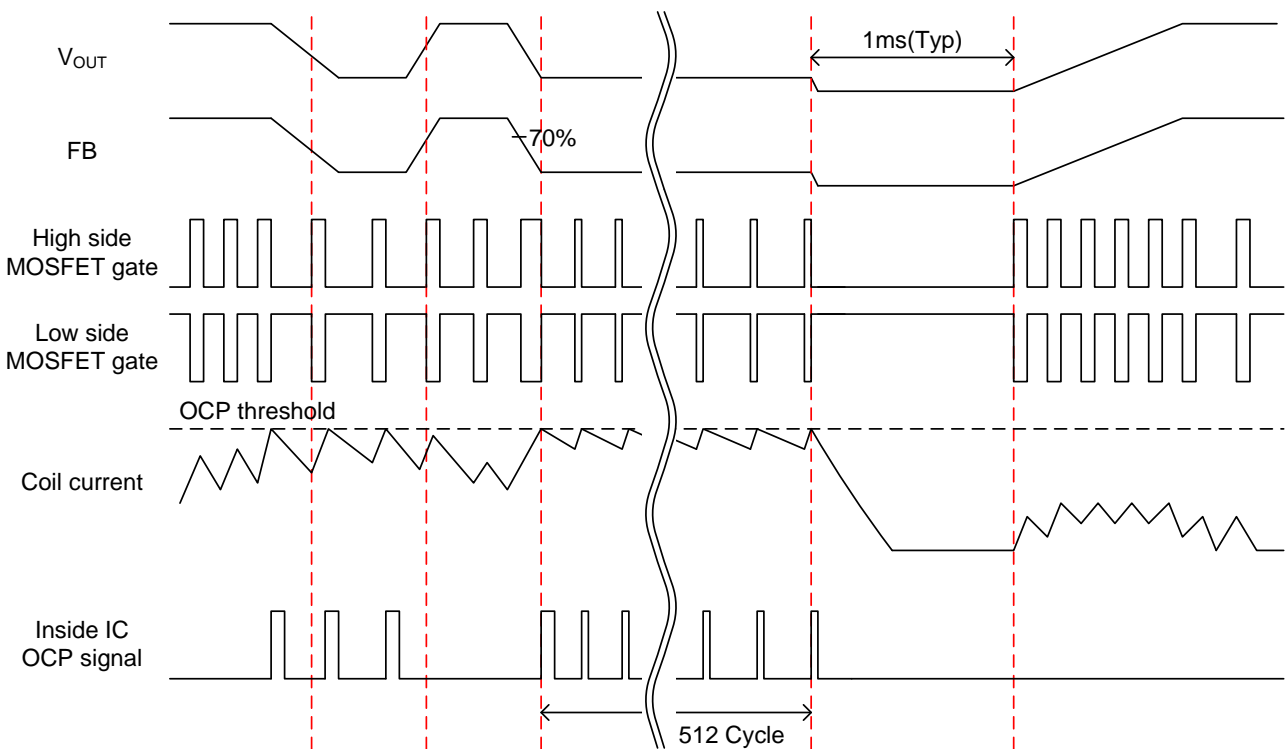

Figure 40. Short Circuit Protection (SCP) Timing Chart

(2) Under Voltage Lockout Protection (UVLO)

The Under Voltage Lockout Protection circuit monitors the VIN terminal voltage. The operation enters standby when the VIN terminal voltage is 2.45V (Typ) or lower. The operation starts when the VIN terminal voltage is 2.55V (Typ) or higher.

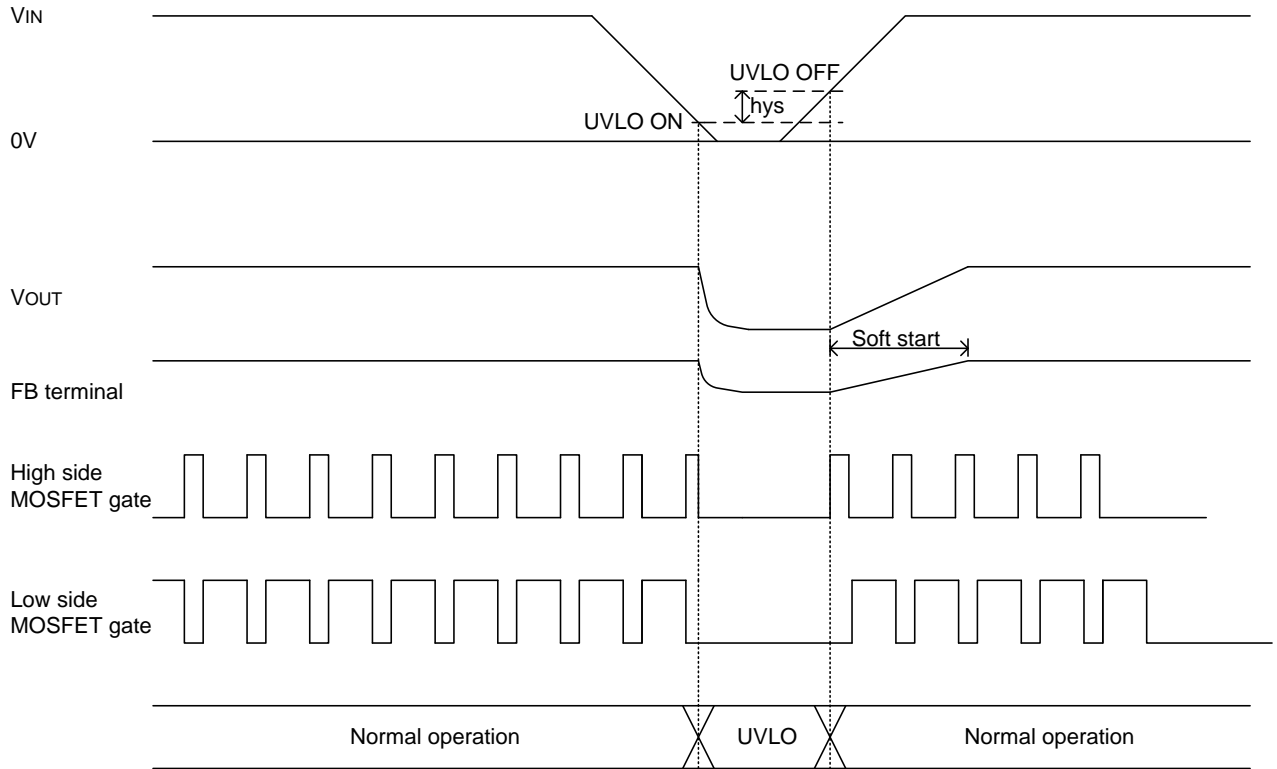

Figure 41. UVLO Timing Chart

(3) Thermal Shutdown

When the chip temperature exceeds $T_j=175^{\circ}\text{C}(\text{Typ})$, the DC/DC converter output is stopped. Thermal protection circuit resets when the temperature falls. The circuit has a hysteresis of $25^{\circ}\text{C}(\text{Typ})$. The thermal shutdown circuit is intended for shutting down the IC from thermal runaway in an abnormal state with the temperature exceeding $T_{j\text{max}}=150^{\circ}\text{C}$. It is not meant to protect or guarantee the soundness of the application. Do not use the function of this circuit for application protection design.

Application Example

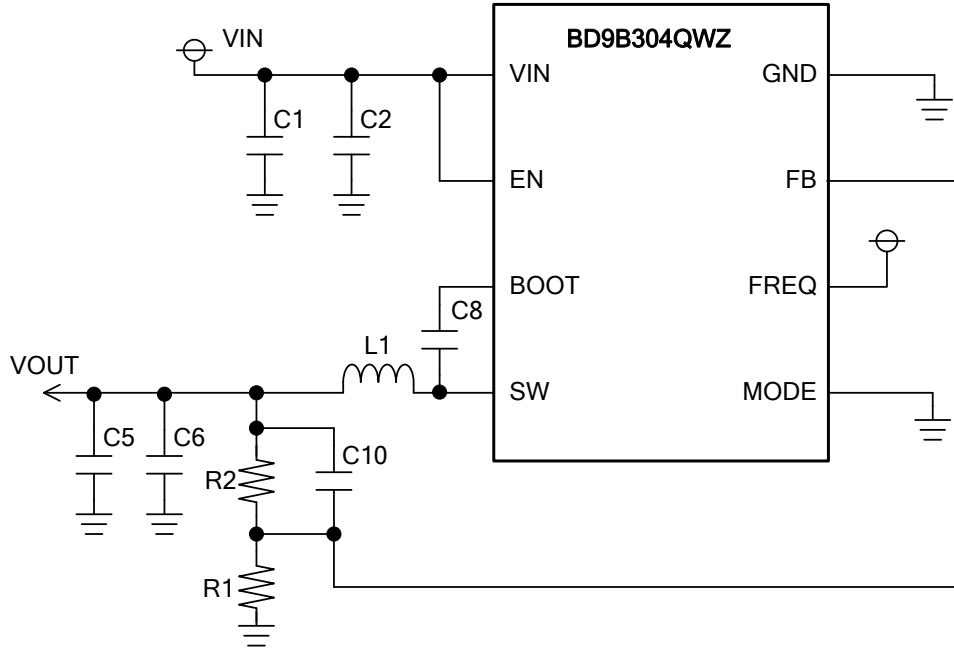

Figure 42. Application Circuit

Table 2. Recommended Component Values (VIN=5V, FREQ=H)

Part No.	V _{OUT}				Company	Part name
	1.0V	1.2V	1.5V	1.8V		
R1	300kΩ	150kΩ	180kΩ	120kΩ	ROHM	MCR01MZPDxxxx
R2	75kΩ	75kΩ	160kΩ	150kΩ	ROHM	MCR01MZPDxxxx
C1 (Note 1)	10μF	10μF	10μF	10μF	Murata	GRM21BB31A106ME18
C2 (Note 2)	0.1μF	0.1μF	0.1μF	0.1μF	Murata	GRM155B11A104MA01D
C5,C6	22μF	22μF	22μF	22μF	Murata	GRM21BB30J226ME38L
C8 (Note 3)	0.1μF	0.1μF	0.1μF	0.1μF	Murata	GRM155B11A104MA01D
C10	120pF	120pF	150pF	180pF	Murata	GRM15 series
L1	1.0μH	1.0μH	1.0μH	1.0μH	TOKO	FDSD0420 DFE252012C

Table 3. Recommended Component Values (VIN=5V, FREQ=L)

Part No.	V _{OUT}				Company	Part name
	1.0V	1.2V	1.5V	1.8V		
R1	300kΩ	150kΩ	180kΩ	120kΩ	ROHM	MCR01MZPDxxxx
R2	75kΩ	75kΩ	160kΩ	150kΩ	ROHM	MCR01MZPDxxxx
C1 (Note 1)	10μF	10μF	10μF	10μF	Murata	GRM21BB31A106ME18
C2 (Note 2)	0.1μF	0.1μF	0.1μF	0.1μF	Murata	GRM155B11A104MA01D
C5,C6	22μF	22μF	22μF	22μF	Murata	GRM21BB30J226ME38L
C8 (Note 3)	0.1μF	0.1μF	0.1μF	0.1μF	Murata	GRM155B11A104MA01D
C10	100pF	100pF	100pF	120pF	Murata	GRM15 series
L1	0.47μH	0.47μH	0.47μH	0.47μH	TOKO	FDSD0420 DFE252012C

(Note 1) For capacitance of input capacitor take temperature characteristics, DC bias characteristics, etc. into consideration to set minimum value to no less than 4.7μF

(Note 2) Connect a 0.1μF ceramic capacitor near to VIN terminal as much as possible.

(Note 3) For capacitance of bootstrap capacitor take temperature characteristics, DC bias characteristics, etc. into consideration to set minimum value to no less than 0.047μF.

Selection of Components Externally Connected

About the application except the recommendation, please contact us.

1. Output LC Filter Constant

In order to supply a continuous current to the load, the DC/DC converter requires an LC filter for smoothing the output voltage. Use inductors of values 0.47μH at FREQ=L or 1.0μH at FREQ=H.

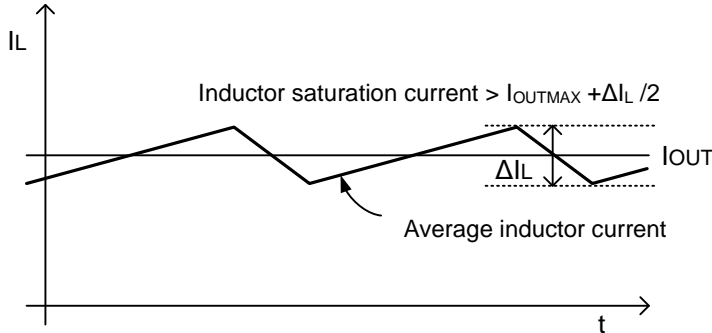

Figure 43. Waveform of current through inductor

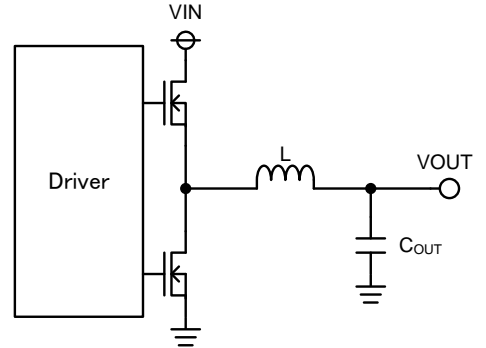

Figure 44. Output LC filter circuit

Inductor ripple current ΔIL

$$\Delta I_L = V_{OUT} \times (V_{IN} - V_{OUT}) \times \frac{1}{V_{IN} \times f_{SW} \times L} = 912 \text{ [mA]}$$

where

$$V_{IN} = 5 \text{ [V]}$$

$$V_{OUT} = 1.2 \text{ [V]}$$

$$L = 1.0 \text{ [}\mu\text{H]}$$

$$f_{sw} = 1 \text{ [MHz]} \text{ (Switching Frequency)}$$

The saturation current of the inductor must be larger than the sum of the maximum output current and 1/2 of the inductor ripple current ΔIL.

The output capacitor COUT affects the output ripple voltage characteristics. The output capacitor COUT must satisfy the required ripple voltage characteristics.

The output ripple voltage can be represented by the following equation.

$$\Delta V_{RPL} = \Delta I_L \times (R_{ESR} + \frac{1}{8 \times C_{OUT} \times f_{SW}}) \text{ [V]}$$

where

R_{ESR} is the Equivalent Series Resistance(ESR) of the output capacitor.

* The capacitor rating must allow a sufficient margin with respect to the output voltage.

The output ripple voltage is decreased with a smaller ESR.

Considering temperature and DC bias characteristics, please use ceramic capacitor of about 22μF to 47μF.

* Be careful of total capacitance value, when additional capacitor CLOAD is connected in addition to output capacitor COUT. Use maximum additional capacitor CLOAD (Max) which satisfies the following condition.

$$\text{Maximum starting inductor ripple current } I_{LSTART} < \text{Over Current limit } 3.7 \text{ [A]} \text{ (min)}$$

Maximum starting inductor ripple current ILSTART can be expressed using the following equation.

$$I_{LSTART} = \text{Maximum starting output current}(I_{OMAX}) + \text{Charge current to output capacitor}(I_{CAP}) + \frac{\Delta I_L}{2}$$

Charge current to output capacitor I_{CAP} can be expressed using the following equation.

$$I_{CAP} = \frac{(C_{OUT} + C_{LOAD}) \times V_{OUT}}{t_{SS}} [A]$$

For example, given $V_{IN} = 5V$, $V_{OUT} = 1.2V$, $L = 1.0\mu H$, switching frequency $f_{SW} = 800kHz$ (Min), Output capacitor $C_{OUT} = 44\mu F$, Soft Start time $t_{SS} = 0.5ms$ (Min), and load current during soft start $I_{OSS} = 3A$, maximum C_{LOAD} can be computed using the following equation.

$$C_{LOAD}(max) < \frac{(3.7 - I_{OSS} - \Delta I_L / 2) \times t_{SS}}{V_{OUT}} - C_{OUT} = 10.2 [\mu F]$$

* C_{LOAD} has an effect on the stability of the DC/DC converter.
To ensure the stability of the DC/DC converter, make sure that a sufficient phase margin is provided.

2. Output Voltage Setting

The output voltage value can be set by the feedback resistance ratio.
For stable operation, use feedback resistance $R2$ more than $20k\Omega$.

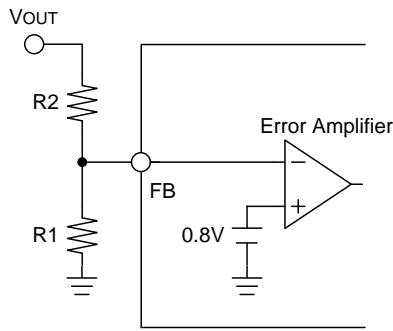

$$V_{OUT} = \frac{R1 + R2}{R1} \times 0.8 [V]$$

$$R1 = \frac{0.8}{V_{OUT} - 0.8} \times R2 [\Omega]$$

$$0.8[V] \leq V_{OUT} \leq (V_{IN} \times 0.8)[V]$$

Figure 45. Feedback Resistor Circuit

3. FB Capacitor

Generally, in fixed ON time control, sufficient ripple voltage in FB voltage is needed to operate comparator stably. Regarding this IC, by injecting ripple voltage to FB voltage inside IC it is designed to correspond to low ESR output capacitor. Please set the FB capacitor within the range of the following expression to inject an appropriate ripple.

$$\frac{V_{OUT} \times (1 - \frac{V_{OUT}}{V_{IN}})}{f_{SW} \times 7.65 \times 10^3} < C_{FB} < \frac{V_{OUT} \times (1 - \frac{V_{OUT}}{V_{IN}})}{f_{SW} \times 3.3 \times 10^3} [F]$$

V_{IN} : Input Voltage[V]

V_{OUT} : Output Voltage[V]

f_{SW} : Switching Frequency[Hz]

4. Bootstrap Capacitor

Connect a $0.1\mu F$ ceramic capacitor between SW terminal and BOOT terminal.

PCB Layout Design

In the step-down DC/DC converter, a large pulse current flows into two loops. The first loop is the one into which the current flows when the High-Side FET is turned ON. The flow starts from the input capacitor C_{IN} , runs through the FET, inductor L and output capacitor C_{OUT} and back to GND of C_{IN} via GND of C_{OUT} . The second loop is the one into which the current flows when the Low-Side FET is turned on. The flow starts from the Low-Side FET, runs through the inductor L and output capacitor C_{OUT} and back to GND of the Low-Side FET via GND of C_{OUT} . Route these two loops as thick and as short as possible to allow noise to be reduced for improved efficiency. It is recommended to connect the input and output capacitors directly to the GND plane. The PCB layout has a great influence on all of the heat generation, noise and efficiency characteristics.

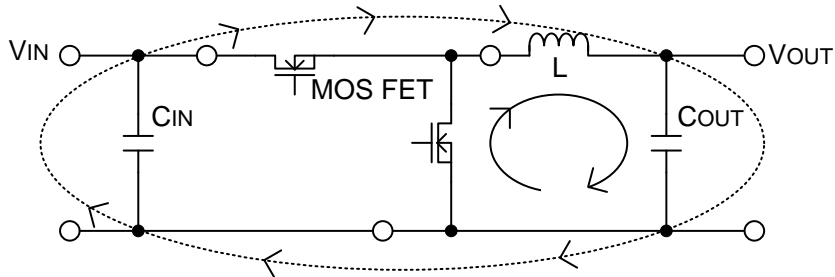

Figure 46. Current Loop of Buck Converter

Accordingly, design the PCB layout considering the following points.

- Connect an input capacitor as close as possible to the IC VIN terminal and GND terminal on the same plane as the IC.
- If there is any unused area on the PCB, provide a copper foil plane for the GND node to assist heat dissipation from the IC and the surrounding components.
- Switching nodes such as SW are susceptible to noise due to AC coupling with other nodes. Route the coil pattern as thick and as short as possible.
- Provide lines connected to FB far from the SW nodes.
- Place the output capacitor away from the input capacitor in order to avoid the effect of harmonic noise from the input.

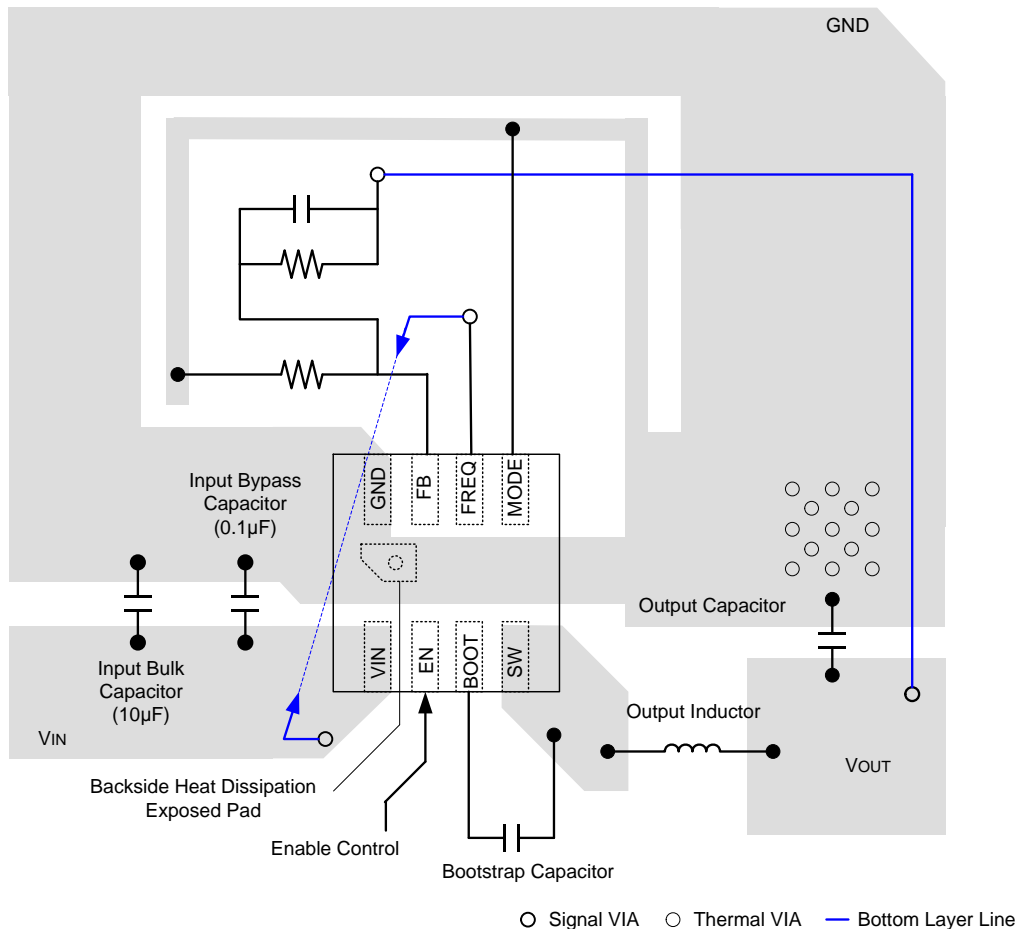
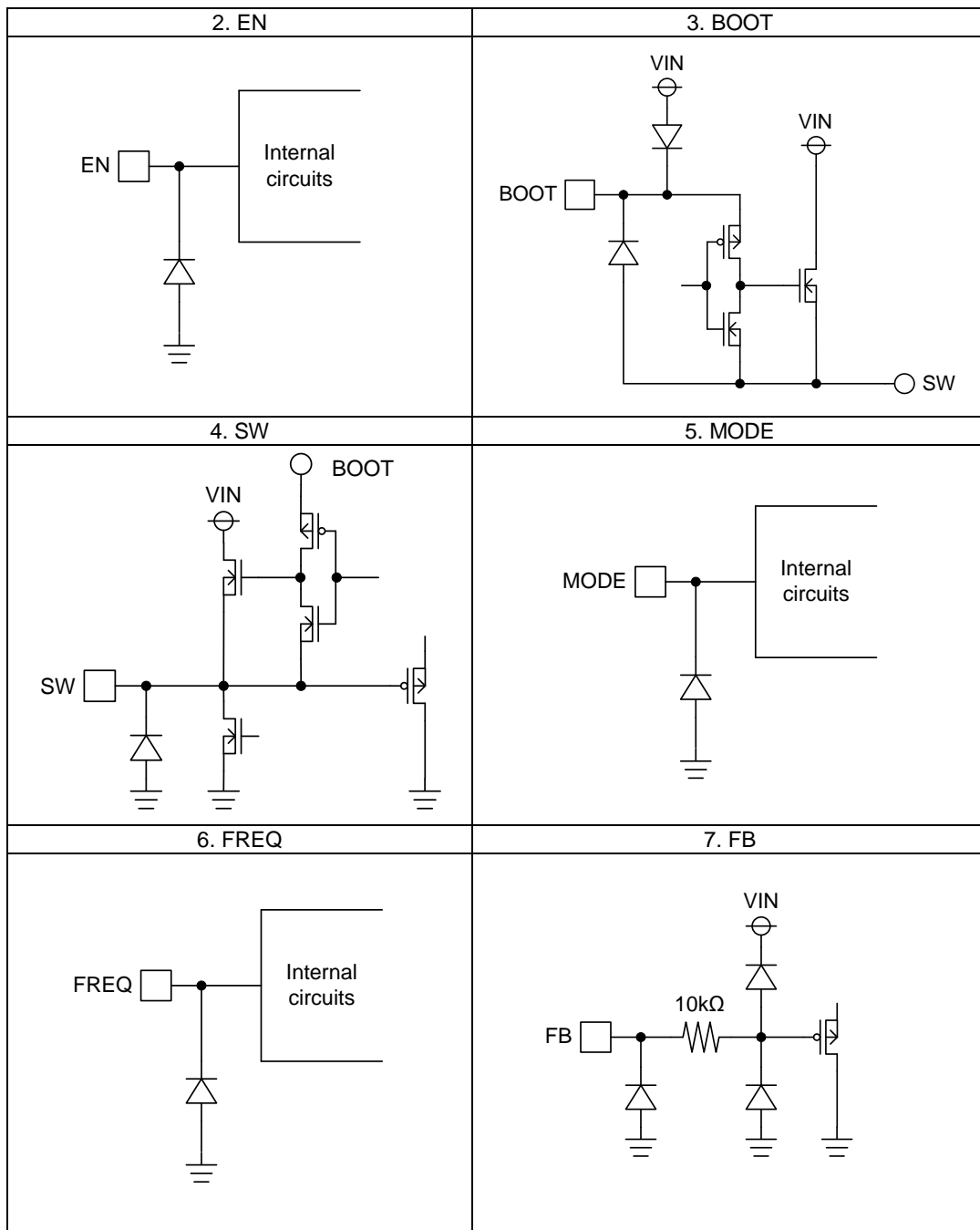

Figure 47. Example of PCB Layout

I/O Equivalence Circuits



Please refer to page6 for electrical characteristics of internal circuits.

Operational Notes

1. Reverse Connection of Power Supply

Connecting the power supply in reverse polarity can damage the IC. Take precautions against reverse polarity when connecting the power supply, such as mounting an external diode between the power supply and the IC's power supply pins.

2. Power Supply Lines

Design the PCB layout pattern to provide low impedance supply lines. Separate the ground and supply lines of the digital and analog blocks to prevent noise in the ground and supply lines of the digital block from affecting the analog block. Furthermore, connect a capacitor to ground at all power supply pins. Consider the effect of temperature and aging on the capacitance value when using electrolytic capacitors.

3. Ground Voltage

Ensure that no pins are at a voltage below that of the ground pin at any time, even during transient condition. However, pins that drive inductive loads (e.g. motor driver outputs, DC-DC converter outputs) may inevitably go below ground due to back EMF or electromotive force. In such cases, the user should make sure that such voltages going below ground will not cause the IC and the system to malfunction by examining carefully all relevant factors and conditions such as motor characteristics, supply voltage, operating frequency and PCB wiring to name a few.

4. Ground Wiring Pattern

When using both small-signal and large-current ground traces, the two ground traces should be routed separately but connected to a single ground at the reference point of the application board to avoid fluctuations in the small-signal ground caused by large currents. Also ensure that the ground traces of external components do not cause variations on the ground voltage. The ground lines must be as short and thick as possible to reduce line impedance.

5. Recommended Operating Conditions

These conditions represent a range within which the expected characteristics of the IC can be approximately obtained. The electrical characteristics are guaranteed under the conditions of each parameter.

6. Inrush Current

When power is first supplied to the IC, it is possible that the internal logic may be unstable and inrush current may flow instantaneously due to the internal powering sequence and delays, especially if the IC has more than one power supply. Therefore, give special consideration to power coupling capacitance, power wiring, width of ground wiring, and routing of connections.

7. Operation Under Strong Electromagnetic Field

Operating the IC in the presence of a strong electromagnetic field may cause the IC to malfunction.

8. Testing on Application Boards

When testing the IC on an application board, connecting a capacitor directly to a low-impedance output pin may subject the IC to stress. Always discharge capacitors completely after each process or step. The IC's power supply should always be turned off completely before connecting or removing it from the test setup during the inspection process. To prevent damage from static discharge, ground the IC during assembly and use similar precautions during transport and storage.

9. Inter-pin Short and Mounting Errors

Ensure that the direction and position are correct when mounting the IC on the PCB. Incorrect mounting may result in damaging the IC. Avoid nearby pins being shorted to each other especially to ground, power supply and output pin. Inter-pin shorts could be due to many reasons such as metal particles, water droplets (in very humid environment) and unintentional solder bridge deposited in between pins during assembly to name a few.

Operational Notes – continued

10. Unused Input Pins

Input pins of an IC are often connected to the gate of a MOS transistor. The gate has extremely high impedance and extremely low capacitance. If left unconnected, the electric field from the outside can easily charge it. The small charge acquired in this way is enough to produce a significant effect on the conduction through the transistor and cause unexpected operation of the IC. So unless otherwise specified, unused input pins should be connected to the power supply or ground line.

11. Regarding the Input Pin of the IC

This monolithic IC contains P+ isolation and P substrate layers between adjacent elements in order to keep them isolated. P-N junctions are formed at the intersection of the P layers with the N layers of other elements, creating a parasitic diode or transistor. For example (refer to figure below):

When $GND > Pin A$ and $GND > Pin B$, the P-N junction operates as a parasitic diode.
When $GND > Pin B$, the P-N junction operates as a parasitic transistor.

Parasitic diodes inevitably occur in the structure of the IC. The operation of parasitic diodes can result in mutual interference among circuits, operational faults, or physical damage. Therefore, conditions that cause these diodes to operate, such as applying a voltage lower than the GND voltage to an input pin (and thus to the P substrate) should be avoided.

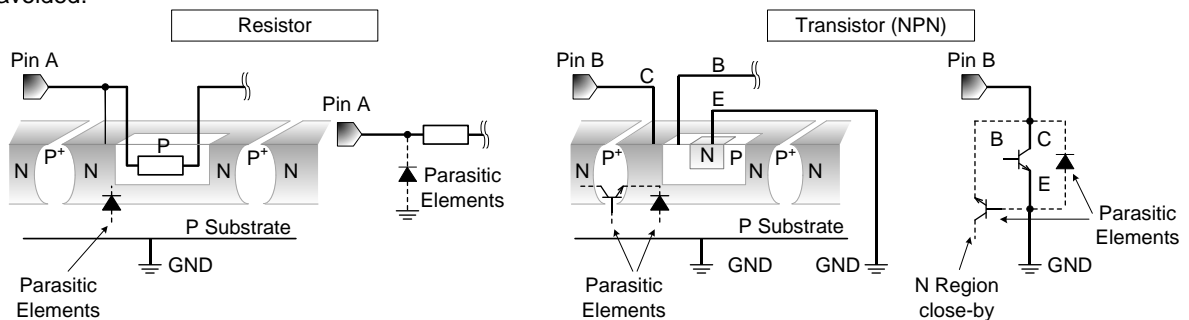

Figure 48. Example of monolithic IC structure

12. Ceramic Capacitor

When using a ceramic capacitor, determine a capacitance value considering the change of capacitance with temperature and the decrease in nominal capacitance due to DC bias and others.

13. Area of Safe Operation (ASO)

Operate the IC such that the output voltage, output current, and the maximum junction temperature rating are all within the Area of Safe Operation (ASO).

14. Thermal Shutdown Circuit(TSD)

This IC has a built-in thermal shutdown circuit that prevents heat damage to the IC. Normal operation should always be within the IC's maximum junction temperature rating. If however the rating is exceeded for a continued period, the junction temperature (T_j) will rise which will activate the TSD circuit that will turn OFF all output pins. When the T_j falls below the TSD threshold, the circuits are automatically restored to normal operation.

Note that the TSD circuit operates in a situation that exceeds the absolute maximum ratings and therefore, under no circumstances, should the TSD circuit be used in a set design or for any purpose other than protecting the IC from heat damage.

15. Over Current Protection Circuit (OCP)

This IC incorporates an integrated overcurrent protection circuit that is activated when the load is shorted. This protection circuit is effective in preventing damage due to sudden and unexpected incidents. However, the IC should not be used in applications characterized by continuous operation or transitioning of the protection circuit.

16. Disturbance light

In a device where a portion of silicon is exposed to light such as in a WL-CSP, IC characteristics may be affected due to photoelectric effect. For this reason, it is recommended to come up with countermeasures that will prevent the chip from being exposed to light.

Ordering Information

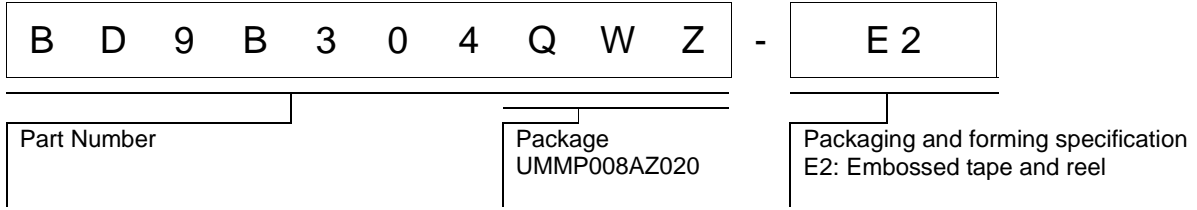

Marking Diagrams

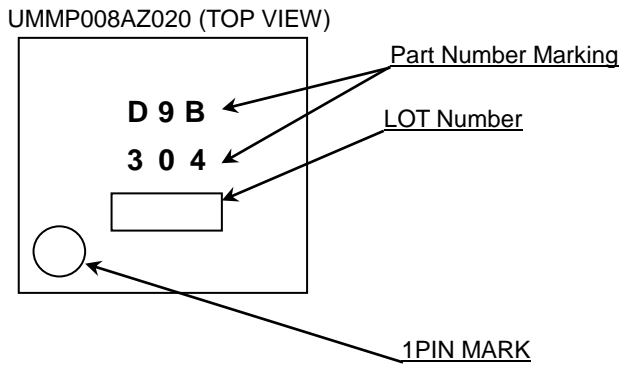

Physical Dimension, Tape and Reel Information

Package Name	UMMP008AZ020
--------------	--------------

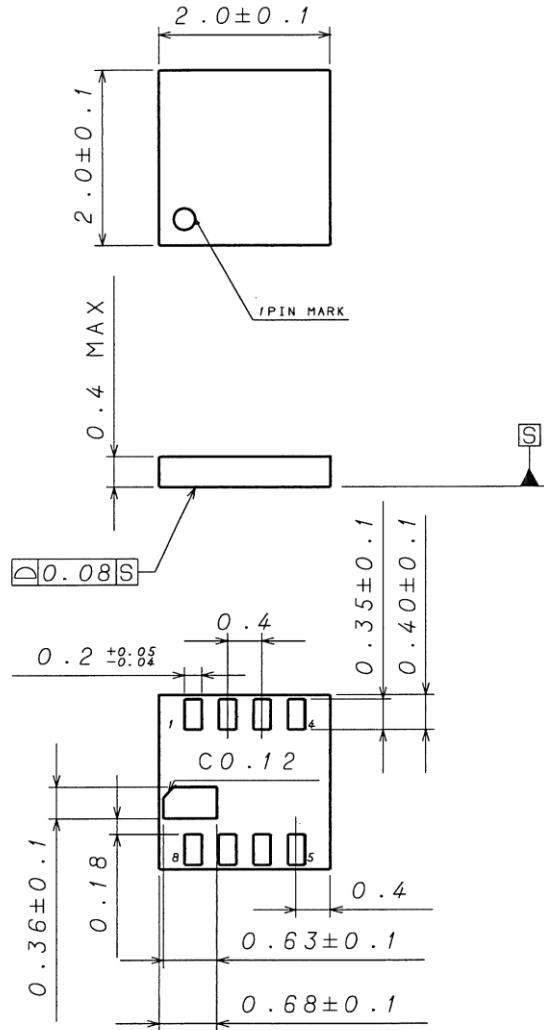

(UNIT : mm)

PKG : UMMP008AZ020

< Tape and Reel Information >

Tape	Embossed carrier tape
Quantity	4000pcs
Direction of feed	E2 The direction is the pin 1 of product is at the upper left when you hold reel on the left hand and you pull out the tape on the right hand

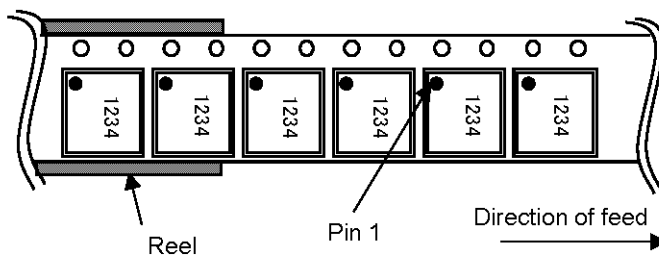

Revision History

Date	Revision	Changes
-	001	Not Release
07.Feb.2017	002	New Release

Notice

Precaution on using ROHM Products

- Our Products are designed and manufactured for application in ordinary electronic equipments (such as AV equipment, OA equipment, telecommunication equipment, home electronic appliances, amusement equipment, etc.). If you intend to use our Products in devices requiring extremely high reliability (such as medical equipment ^(Note 1), transport equipment, traffic equipment, aircraft/spacecraft, nuclear power controllers, fuel controllers, car equipment including car accessories, safety devices, etc.) and whose malfunction or failure may cause loss of human life, bodily injury or serious damage to property ("Specific Applications"), please consult with the ROHM sales representative in advance. Unless otherwise agreed in writing by ROHM in advance, ROHM shall not be in any way responsible or liable for any damages, expenses or losses incurred by you or third parties arising from the use of any ROHM's Products for Specific Applications.

(Note1) Medical Equipment Classification of the Specific Applications

JAPAN	USA	EU	CHINA
CLASS III	CLASS III	CLASS II b	CLASS III
CLASS IV		CLASS III	

- ROHM designs and manufactures its Products subject to strict quality control system. However, semiconductor products can fail or malfunction at a certain rate. Please be sure to implement, at your own responsibilities, adequate safety measures including but not limited to fail-safe design against the physical injury, damage to any property, which a failure or malfunction of our Products may cause. The following are examples of safety measures:
 - Installation of protection circuits or other protective devices to improve system safety
 - Installation of redundant circuits to reduce the impact of single or multiple circuit failure
- Our Products are designed and manufactured for use under standard conditions and not under any special or extraordinary environments or conditions, as exemplified below. Accordingly, ROHM shall not be in any way responsible or liable for any damages, expenses or losses arising from the use of any ROHM's Products under any special or extraordinary environments or conditions. If you intend to use our Products under any special or extraordinary environments or conditions (as exemplified below), your independent verification and confirmation of product performance, reliability, etc. prior to use, must be necessary:
 - Use of our Products in any types of liquid, including water, oils, chemicals, and organic solvents
 - Use of our Products outdoors or in places where the Products are exposed to direct sunlight or dust
 - Use of our Products in places where the Products are exposed to sea wind or corrosive gases, including Cl₂, H₂S, NH₃, SO₂, and NO₂
 - Use of our Products in places where the Products are exposed to static electricity or electromagnetic waves
 - Use of our Products in proximity to heat-producing components, plastic cords, or other flammable items
 - Sealing or coating our Products with resin or other coating materials
 - Use of our Products without cleaning residue of flux (even if you use no-clean type fluxes, cleaning residue of flux is recommended); or Washing our Products by using water or water-soluble cleaning agents for cleaning residue after soldering
 - Use of the Products in places subject to dew condensation
- The Products are not subject to radiation-proof design.
- Please verify and confirm characteristics of the final or mounted products in using the Products.
- In particular, if a transient load (a large amount of load applied in a short period of time, such as pulse. is applied, confirmation of performance characteristics after on-board mounting is strongly recommended. Avoid applying power exceeding normal rated power; exceeding the power rating under steady-state loading condition may negatively affect product performance and reliability.
- De-rate Power Dissipation depending on ambient temperature. When used in sealed area, confirm that it is the use in the range that does not exceed the maximum junction temperature.
- Confirm that operation temperature is within the specified range described in the product specification.
- ROHM shall not be in any way responsible or liable for failure induced under deviant condition from what is defined in this document.

Precaution for Mounting / Circuit board design

- When a highly active halogenous (chlorine, bromine, etc.) flux is used, the residue of flux may negatively affect product performance and reliability.
- In principle, the reflow soldering method must be used on a surface-mount products, the flow soldering method must be used on a through hole mount products. If the flow soldering method is preferred on a surface-mount products, please consult with the ROHM representative in advance.

For details, please refer to ROHM Mounting specification

Precautions Regarding Application Examples and External Circuits

1. If change is made to the constant of an external circuit, please allow a sufficient margin considering variations of the characteristics of the Products and external components, including transient characteristics, as well as static characteristics.
2. You agree that application notes, reference designs, and associated data and information contained in this document are presented only as guidance for Products use. Therefore, in case you use such information, you are solely responsible for it and you must exercise your own independent verification and judgment in the use of such information contained in this document. ROHM shall not be in any way responsible or liable for any damages, expenses or losses incurred by you or third parties arising from the use of such information.

Precaution for Electrostatic

This Product is electrostatic sensitive product, which may be damaged due to electrostatic discharge. Please take proper caution in your manufacturing process and storage so that voltage exceeding the Products maximum rating will not be applied to Products. Please take special care under dry condition (e.g. Grounding of human body / equipment / solder iron, isolation from charged objects, setting of Ionizer, friction prevention and temperature / humidity control).

Precaution for Storage / Transportation

1. Product performance and soldered connections may deteriorate if the Products are stored in the places where:
 - [a] the Products are exposed to sea winds or corrosive gases, including Cl₂, H₂S, NH₃, SO₂, and NO₂
 - [b] the temperature or humidity exceeds those recommended by ROHM
 - [c] the Products are exposed to direct sunshine or condensation
 - [d] the Products are exposed to high Electrostatic
2. Even under ROHM recommended storage condition, solderability of products out of recommended storage time period may be degraded. It is strongly recommended to confirm solderability before using Products of which storage time is exceeding the recommended storage time period.
3. Store / transport cartons in the correct direction, which is indicated on a carton with a symbol. Otherwise bent leads may occur due to excessive stress applied when dropping of a carton.
4. Use Products within the specified time after opening a humidity barrier bag. Baking is required before using Products of which storage time is exceeding the recommended storage time period.

Precaution for Product Label

A two-dimensional barcode printed on ROHM Products label is for ROHM's internal use only.

Precaution for Disposition

When disposing Products please dispose them properly using an authorized industry waste company.

Precaution for Foreign Exchange and Foreign Trade act

Since concerned goods might be fallen under listed items of export control prescribed by Foreign exchange and Foreign trade act, please consult with ROHM in case of export.

Precaution Regarding Intellectual Property Rights

1. All information and data including but not limited to application example contained in this document is for reference only. ROHM does not warrant that foregoing information or data will not infringe any intellectual property rights or any other rights of any third party regarding such information or data.
2. ROHM shall not have any obligations where the claims, actions or demands arising from the combination of the Products with other articles such as components, circuits, systems or external equipment (including software).
3. No license, expressly or implied, is granted hereby under any intellectual property rights or other rights of ROHM or any third parties with respect to the Products or the information contained in this document. Provided, however, that ROHM will not assert its intellectual property rights or other rights against you or your customers to the extent necessary to manufacture or sell products containing the Products, subject to the terms and conditions herein.

Other Precaution



1. This document may not be reprinted or reproduced, in whole or in part, without prior written consent of ROHM.
2. The Products may not be disassembled, converted, modified, reproduced or otherwise changed without prior written consent of ROHM.
3. In no event shall you use in any way whatsoever the Products and the related technical information contained in the Products or this document for any military purposes, including but not limited to, the development of mass-destruction weapons.
4. The proper names of companies or products described in this document are trademarks or registered trademarks of ROHM, its affiliated companies or third parties.

General Precaution





1. Before you use our Products, you are requested to carefully read this document and fully understand its contents. ROHM shall not be in any way responsible or liable for failure, malfunction or accident arising from the use of any ROHM's Products against warning, caution or note contained in this document.
2. All information contained in this document is current as of the issuing date and subject to change without any prior notice. Before purchasing or using ROHM's Products, please confirm the latest information with a ROHM sales representative.
3. The information contained in this document is provided on an "as is" basis and ROHM does not warrant that all information contained in this document is accurate and/or error-free. ROHM shall not be in any way responsible or liable for any damages, expenses or losses incurred by you or third parties resulting from inaccuracy or errors of or concerning such information.

Looking for pricing, stock, or lifecycle information?

Click below to explore more details on WIN SOURCE:

-  [View BD9B304QWZ-E2 on WIN SOURCE](#)
-  [Rohm Semiconductor](#) Information

Optimize Your Supply Chain with WIN SOURCE Solutions

-  Global Sourcing Solution
-  Obsolete Management
-  Cost Control Management
-  Shortage Management
-  Alternative Solution
-  Excess Inventory Management