



**THE DATASHEET OF
BP5250-24**



DC/DC converter

BP5250/BP5250-24

The BP5250/BP5250-24 are DC/DC converters for step-down that can drive PchFET using PWM system. The voltage setting resistor and the combination of external power elements enable you to make any power circuit to your liking. High-efficient DC/DC converter can be made easy by adding external components such as I/O smoothing capacitor without designing circuit.

● Applications

OA appliances(copy machine, personal computer, facsimile), AV appliances (car navigation, DVD etc.), and industrial appliances.

● Features

- 1) High power conversion($\eta=90\%$ $V_{in}=12V$ 5V/2A)
- 2) Power save pin(Leakage current at OFF mode : $I_R=10\mu A_{MAX}$)
- 3) Output voltage can be established from 1.5V to 9V in the VADJ pin.(For BP5250, however, output voltage is limited by input voltage.)
- 4) With recovery type overcurrent protection function (Detection current can be established by the external current detection resistance.)
- 5) Power circuit can be made easy by adding external smoothing capacitor and power element.
- 6) Reference voltage accuracy $1.25V\pm 1\%$

● Absolute maximum ratings ($T_a=25^\circ C$)

| Parameter | Symbol | Limits | | Unit | Condition |
|-----------------------------------|-------------|------------|-----------|------------|---|
| | | BP5250 | BP5250-24 | | |
| Input voltage | V_i | 24 | 30 | V | DC |
| ESD endurance | V_{surge} | 1 | | kV | (EIAJ ED4701-1C-111A) |
| Operating temperature range | T_{opr} | -40 ~ +85 | | $^\circ C$ | |
| Storage temperature range | T_{stg} | -50 ~ +100 | | $^\circ C$ | |
| Allowable max surface temperature | T_{fmax} | 100 | | $^\circ C$ | Ambient temperature+The module self-heating $\leq T_{fmax}$ |
| The power saving terminal voltage | V_{CTL} | 24 | 30 | V | $V_i \geq V_{CTL}$ |

● Recommended operating conditions ($T_a=25^\circ C$)

| Parameter | | Symbol | Min. | Typ. | Max. | Unit |
|---------------|-----------|--------|------|------|------|------|
| Input voltage | BP5250 | V_i | 8 | 12 | 16 | V |
| | BP5250-24 | | 20 | 24 | 27 | V |

● Block diagram

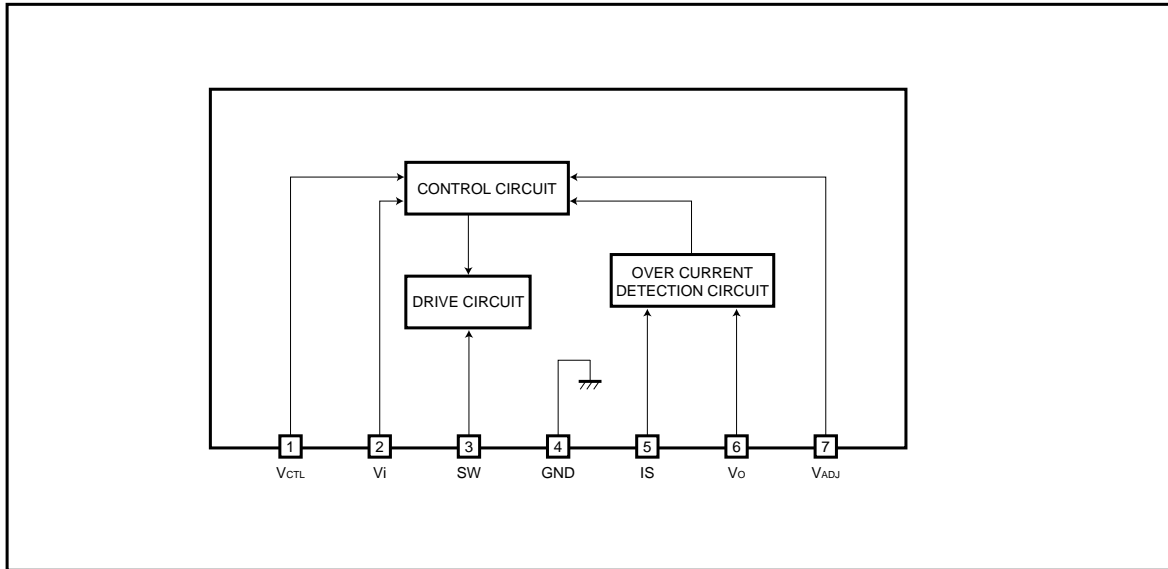

● Pin descriptions

| Pin No. | Pin name | Function |
|---------|------------------|--|
| 1 | V _{CTL} | Power save terminal. Setting the voltage on this terminal to Low or high impedance turns the output OFF. Normally connect to V _i for use. |
| 2 | V _i | Input voltage terminal. Inserting a bypass capacitor of 0.1μF between this and pin 4 GND is recommended. |
| 3 | SW | Terminal to drive the external FET gate. |
| 4 | GND | GND terminal. Connect the negative terminal of the I/O smoothing capacitor and the anode terminal of the flywheel diode nearby. |
| 5 | IS | Overcurrent detection terminal. The value of the resistor inserted between this and pin 6 sets the output current capacity. |
| 6 | V _o | Output voltage monitor terminal. |
| 7 | V _{ADJ} | Output voltage setting terminal. The values of the resistors inserted between this and pin 6 and between this and GND set the output voltage capacity. |

● **Electrical characteristics** (Unless otherwise noted, $V_i=12V$: BP5250, $V_i=24V$: BP5250-24, $T_a=25^\circ C$)

| Parameter | Symbol | Min. | Typ. | Max. | Unit | Conditions | Test Circuit |
|---|------------|-------|------|-------|---------|-------------------------|--------------|
| Output ADJ Pin voltage | V_{ADJ} | 1.225 | 1.25 | 1.275 | V | VSW L→H | Fig.1 |
| Over current detection off set voltage1 | V_{LT1} | 60 | 68 | 76 | mV | VSW L→H $V_{ADJ}=1.25V$ | Fig.2 |
| Over current detection off set voltage2 | V_{LT2} | 20 | 28 | 36 | mV | VSW L→H $V_{ADJ}=0V$ | Fig.2 |
| CTL pin ON voltage | V_{CTLH} | 2 | - | - | V | VSW H→L | Fig.3 |
| CTL pin OFF voltage | V_{CTLL} | - | - | 1 | V | VSW L→H | Fig.3 |
| CTL sink current | I_{CTL} | 40 | 50 | 70 | μA | $V_{CTL}=5V$ | Fig.3 |
| Stand by current | I_{STB} | - | 0 | 10 | μA | $V_{CTL}=0V$ | Fig.3 |

● **Measurement circuit**

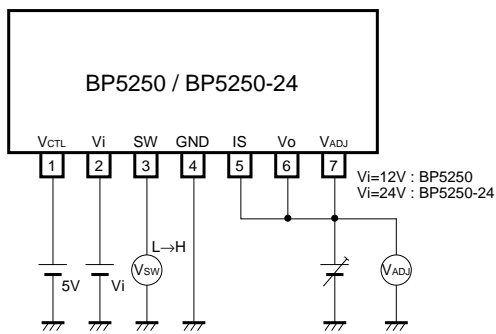
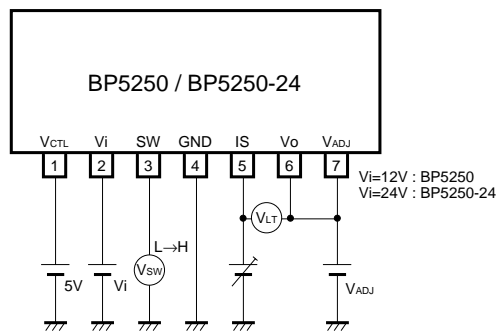
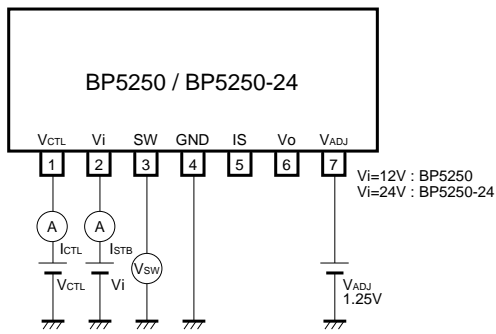

Fig.1 Output ADJ terminal voltage measurement circuit



Over current detection off set voltage 1 : $V_{ADJ}=1.25V$
 Over current detection off set voltage 2 : $V_{ADJ}=0V$

Fig.2 Over current detection off set voltage measurement circuit



CTL sink current : $V_{CTL}=5V$
 Stand by current : $V_{CTL}=0V$

Fig.3 Control terminal voltage sink current - Stand by sink current measurement circuit

● Application example

(1) Application circuit example is shown in the Fig.4.

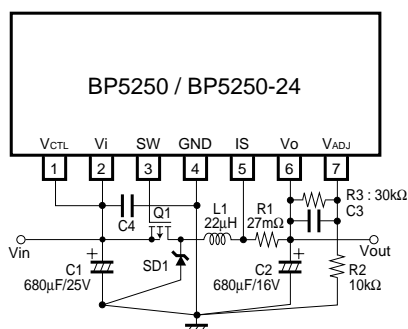

Fig.4

*Application

- Input voltage 12V
- Output current 2A
- Output voltage 5V
- Q1 : 2SJ529S/Hitachi
- SD : RB050L-40/ROHM
- L1 : CDRH124-220L/Sumida
- C1 : 680μF/25V (ZL series)/Rubycon
- C2 : 680μF/10V (ZL series)/Rubycon
- C3 : 0.1μF/16V
- C4 : 0.1μF/25V

- There is a possibility that the C1 exceeds the allowable ripple current. Note the allowable ripple current of the capacitor to be used.
- $R2+R3 \leq 55k\Omega$ is recommended for R2,3 to make the most of output voltage accuracy.
- Output voltage range is limited by input voltage. Please refer to the Fig.8.

R1 : Over-current detection resistance $R1=0.068V / (0.068V : \text{offset voltage})$
 Overcurrent protection characteristic at $R1=27m\Omega$ is shown below.

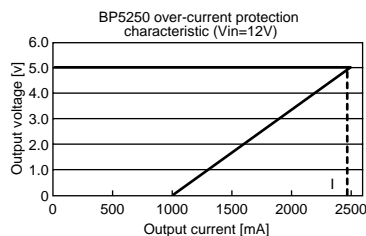

R2, R3 : Output voltage establishment resistance

$$V_o = V_{ADJ} \times (1 + R_3/R_2)$$

($R_2 + R_3 \leq 55k\Omega$)

| Establishment example | | | |
|-----------------------|-------|-------|--|
| Vo(V) | R2(Ω) | R3(Ω) | |
| 8.0 | 3.3k | 18k | |
| 5.0 | 10k | 30k | |
| 3.3 | 20k | 33k | |
| 2.5 | 10k | 10k | |
| 1.5 | 10k | 2k | |

(2) When the load current is increased.

It is possible by arrangement in a parallel connecting Q1, 2 and SD1,2

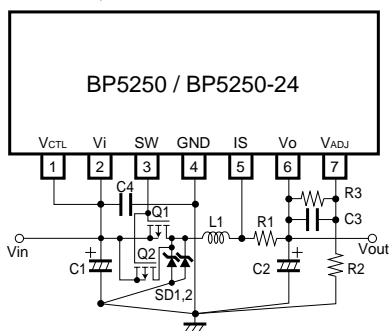

Fig.5

- When Q1 and Q2 are connected parallel, use of a device with small gate capacity is recommended. Large gate capacity reduces the switching speed, which may cause a larger FET loss, exceeding the allowable loss value.
- When 2SJ529S is connected parallel, the rated load current 3A is the maximum at $V_i=12V, V_o=5V$

(3) When the power saving function is used.

The output is off when the VCTL pin is set to the Low or high-impedance.

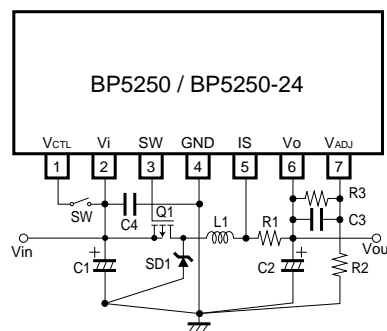

Fig.6

● Output voltage establishment range

Output voltage establishment range is changed by input voltage. Please refer to the Fig.8.

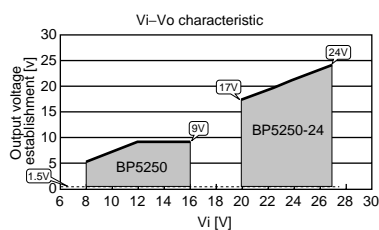

Fig.8

● Caution note for operation

- (1) Output voltage establishment range is changed by input voltage. Please refer to the Fig.8.
- (2) Layout of external parts may significantly change the output spike noise or characteristics or cause abnormal oscillation and temperature increase. Note the following for layout.
 - Provide the input smoothing electrolytic capacitor close to the FET source and pin 2 of the module.
 - Provide the output smoothing electrolytic capacitor close to pin 6 of the module together with the current detection resistor
 - Large current may run into the coil, current detection resistor and output through the FET source-drain. Try to use a solid pattern as much as possible.
 - FET drain, coil and flywheel diode may generate heat by power loss. Try to use a solid pattern so that the heat may be released. Measure a rise in temperature of each element and make sure that it is not abnormal.
 - Provide the negative terminal of the I/O smoothing capacitor and anode terminal of the flywheel diode close to GND pin 4 of the module.
 - Connect the negative terminal of the I/O smoothing electrolytic capacitor and anode terminal of the flywheel diode nearby.
- (3) Output load may cause large ripple current in the I/O smoothing electrolytic capacitor. Note the allowable ripple current of the capacitor to be used.
- (4) As the output smoothing electrolytic capacitor, one with especially low impedance is recommended for suppressing output ripple voltage. Select a capacitor suited for the use.
- (5) Please be sure to use protection circuit function. (R1 should not be 0Ω.)

● Output voltage establishment and application circuit example

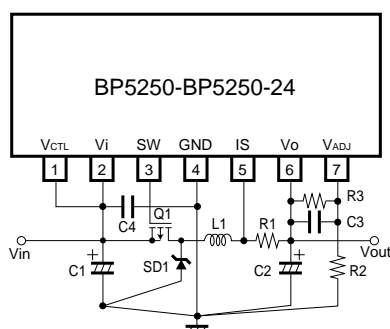

Fig.9

*Application example

Input voltage 12V

Output voltage 5V

Q1 : 2SJ529S/hitachi

SD : RB050L-40/ROHM

L1 : CDRH124-220L/Sumida

C1 : 680μF/25V (zL series)/Rubycon

C2 : 680μF/16V (zL series)/Rubycon

C3 : 0.1μF/16V/ROHM

C4 : 0.1μF/25V/ROHM

R1 : 27mΩ/SUSUMU

R2 : 10kΩ/ROHM

R3 : 30kΩ/ROHM

(1) Output voltage and resistance

Output voltage V_o is determined by output ADJ pin voltage(V_{ADJ}) and R_2 , R_3 .

$$V_o = V_{ADJ} \times (1 + R_3/R_2) [V] \quad V_{ADJ} = 1.25V$$

Note) Please set the resistance to $R_2 + R_3 \leq 55K\Omega$ to make the best use of this module performance.

| Establishment example | | |
|-----------------------|---------------|---------------|
| $V_o(V)$ | $R_2(\Omega)$ | $R_3(\Omega)$ |
| 8.0 | 3.3k | 18k |
| 5.0 | 10k | 30k |
| 3.3 | 20k | 33k |
| 2.5 | 10k | 10k |
| 1.5 | 10k | 2k |

(2) FET(Q1)

FET is determined by taking the peak current flowed to the external FET, drain-source voltage(V_{DS}), ON resistance($R_{DS(ON)}$), input capacity(C_{iss}), allowable loss of package, and area of safe operation.

For the basic circuit example(Fig.9), FET of 2SJ529S/Hitachi is used.

Please use FET with the characteristic equal to or than this one. Especially, the input capacity(C_{iss}), and ON resistance may cause a larger FET loss. Note the FET with the characteristic equal to or higher to be used.

The characteristic of 2SJ529S is

$V_{DS} = -60V$
 $I_D = -10A$
 $R_{DS(ON)} = 0.17\Omega$ TYP ($I_D = -5A$, $V_{DS} = -4V$)
 $P_{ch} = 20W$ ($T_c = 25^\circ C$)
 $C_{iss} = 580PF$

(3) Inductor(L1)

inductor L1 is determined by the following expression in consideration of output ripple current.

$$L1 \geq n \times (V_i - V_o) / I_o \times 1/f \times V_o / V_i [H]$$

V_i : Input voltage [V]
 V_o : Output voltage [V]
 I_o : Output current [A]
 f : Oscillation frequency ($\approx 190KHz$)
 n : Ripple current condition
 I_o/n is ripple current. Normally, $n=2.5\sim 5$ is recommended.

L is determined from above.

Peak current flowed into the inductor by the determined L is

$$I_p = I_o + (V_i - V_o) / 2 \times 1/L1 \times 1/f \times (1 - V_o/V_i) [A]$$

I_p for actual usage is calculated back by the L of the expression above.

Ripple current I_r by the determined L is

$$I_r = (V_i - V_o) / L1 \times 1/f \times V_o / V_i [A]$$

As stated above, after $L1[H]$ inductor and the $I_p[A]$ peak current are determined, an inductor for these specifications can be determined. Output ripple voltage is determined by the multiplication of the $I_r[A]$ ripple current and the impedance of the smoothing capacitor.

$$V_r = I_r \times Z_c$$

V_r : Output ripple voltage [V_{p-p}]

Z_c : Impedance of smoothing capacitor [Ω]

(4) Flywheel diode(SD1)

- Rated current must be twice as much as the maximum overload current(Iomax) or more.
- Rated voltage must be 1.3 times as much as the maximum input voltage or more.
- Please use the high-speed switching schottky barrier diode that reverse recovery time is 50ns or less.
- If it used in high temperature, please be careful about the temperature characteristics of IR.

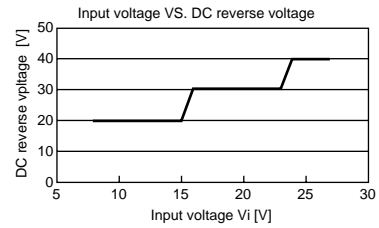

(5) Overcurrent detection resistor(R1)

Overcurrent detection resistor is determined by the following expression.

$$R1 = VLT1 / I_{omax} \text{ [m}\Omega\text{]}$$

VLT1 : Overcurrent offset voltage1(60~76mV)

Iomax : Maximum overload current [A]

And, ISL current at short circuit is

$$ISL = VLT2 / R1 \text{ [A]}$$

VLT2 : Overcurrent detection offset voltage2(20~36mV)

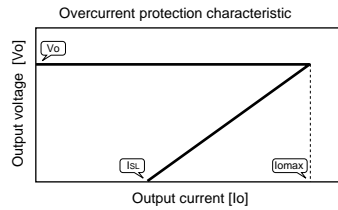

From the above-mentioned, fold-back current characteristic when the overcurrent protection is operated is shown. Both Iomax, and ISL may be different value from the actual value because they are detected at the peak current. Please make sure to confirm it in the actual operating.

(6) Input smoothing capacitor(C1)

Large ripple current flow into the input smoothing capacitor. The current is determined by the following expression. For actual usage, please use the larger one than this numeric value.

$$I_{rms} = i_r \times \sqrt{V_o / 3V_i} + (i_p - i_r) \times \sqrt{V_o / V_i} \text{ [A]}$$

I_{rms} : Input ripple current actual-value [Arms]

i_r : Ripple current [A]

i_p : Peak current [A]

V : Input voltage [V]

V_o : Output voltage [V]

- Voltage of the used capacitor must be more than Vi × 2.
- Allowable ripple current of the used capacitor must be larger than the ripple current.

(7) Output smoothing capacitor(C2)

Output smoothing capacitor is determined by the impedance of smoothing capacitor from the mark value of output ripple voltage.

$$Z_c \leq V_r / i_r \text{ [}\Omega\text{]}$$

Z_c : Impedance of capacitor [Ω]

V_r : Mark value of output ripple voltage[Vp-p]

i_r : Ripple current [A]

- Voltage of the used capacitor must be more than Vo × 2.
- Allowable ripple current of the used capacitor must be larger than the ripple current.

● External dimensions (Units : mm)

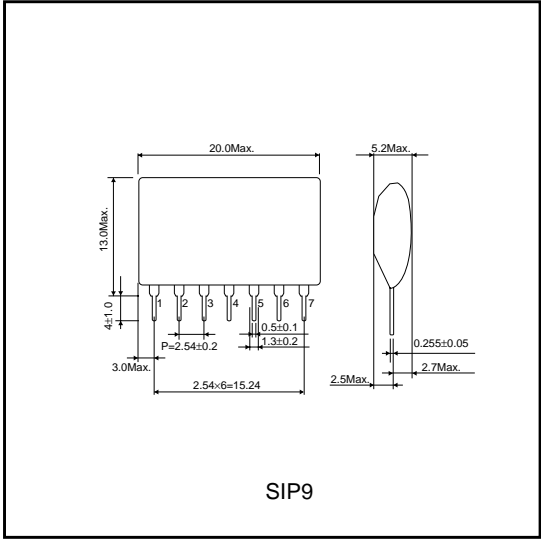

● BP5250 external reference components

Input voltage 12V

| Output current | 1A | | | | | Note |
|----------------|-------------------|-------------------|-------------------|-------------------|-------------------|------------------------|
| output voltage | 1.5V±3% | 2.5V±3% | 3.3V±3% | 5V±3% | 8V±3% | |
| Q 1 | CPH6306 | CPH6306 | CPH6306 | CPH6306 | CPH6306 | |
| SD1 | RB050L-40 | RB050L-40 | RB050L-40 | RB050L-40 | RB050L-40 | |
| L1 | 17~34μH±10% | 26~52μH±10% | 31~63μH±10% | 38~77μH±10% | 35~70μH±10% | Rated current |
| | 1.3A or higher | 1.3A or higher | 1.3A or higher | 1.4A or higher | 1.5A or higher | |
| C1 | 0.4Arms or higher | 0.5Arms or higher | 0.6Arms or higher | 0.7Arms or higher | 0.9Arms or higher | Allowable ripple curmt |
| | 220~4700μF | 220~4700μF | 220~4700μF | 220~4700μF | 330~4700μF | |
| C2 | 0.3Arms or higher | 0.3Arms or higher | 0.3Arms or higher | 0.3Arms or higher | 0.3Arms or higher | Allowable ripple curmt |
| | 220~1000μF | 220~1000μF | 220~1000μF | 220~1000μF | 220~1000μF | |
| C3 | 0.1μF/16V (R) | 0.1μF/16V (R) | 0.1μF/16V (R) | 0.1μF/16V (R) | 0.1μF/16V (R) | |
| C4 | 0.1μF/25V (R) | 0.1μF/25V (R) | 0.1μF/25V (R) | 0.1μF/25V (R) | 0.1μF/25V (R) | |
| R1 | 56mΩ±5% less than | 56mΩ±5% less than | 56mΩ±5% less than | 56mΩ±5% less than | 56mΩ±5% less than | |
| R2 | 10kΩ±1% | 10kΩ±1% | 20kΩ±1% | 10kΩ±1% | 3.3kΩ±1% | |
| R3 | 2kΩ±1% | 10kΩ±1% | 33kΩ±1% | 30kΩ±1% | 18kΩ±1% | |

| Output current | 2A | | | | | Note |
|----------------|-------------------|-------------------|-------------------|-------------------|-------------------|------------------------|
| output voltage | 1.5V±3% | 2.5V±3% | 3.3V±3% | 5V±3% | 8V±3% | |
| Q 1 | 2SJ529S | 2SJ529S | 2SJ529S | 2SJ529S | 2SJ529S | |
| SD1 | RB050L-40 | RB050L-40 | RB050L-40 | RB050L-40 | RB050L-40 | |
| L1 | 9~17μH±10% | 13~26μH±10% | 16~31μH±10% | 19~38μH±10% | 17~35μH±10% | Rated current |
| | 2.5A or higher | 2.5A or higher | 2.5A or higher | 2.5A or higher | 2.6A or higher | |
| C1 | 0.8Arms or higher | 1Arms or higher | 1Arms or higher | 1.5Arms or higher | 1.8Arms or higher | Allowable ripple curmt |
| | 330~4700μF | 330~4700μF | 330~4700μF | 680~4700μF | 680~4700μF | |
| C2 | 0.6Arms or higher | 0.6Arms or higher | 0.6Arms or higher | 0.6Arms or higher | 0.7Arms or higher | Allowable ripple curmt |
| | 560~1500μF | 560~1500μF | 560~1500μF | 560~1500μF | 560~1500μF | |
| C3 | 0.1μF/16V (R) | 0.1μF/16V (R) | 0.1μF/16V (R) | 0.1μF/16V (R) | 0.1μF/16V (R) | |
| C4 | 0.1μF/25V (R) | 0.1μF/25V (R) | 0.1μF/25V (R) | 0.1μF/25V (R) | 0.1μF/25V (R) | |
| R1 | 27mΩ±5% less than | 27mΩ±5% less than | 27mΩ±5% less than | 27mΩ±5% less than | 27mΩ±5% less than | |
| R2 | 10kΩ±1% | 10kΩ±1% | 20kΩ±1% | 10kΩ±1% | 3.3kΩ±1% | |
| R3 | 2kΩ±1% | 10kΩ±1% | 33kΩ±1% | 30kΩ±1% | 18kΩ±1% | |

| Output current | 3A | | | | | Note |
|----------------|-------------------|-------------------|-------------------|-------------------|-------------------|------------------------|
| output voltage | 1.5V±3% | 2.5V±3% | 3.3V±3% | 5V±3% | 8V±3% | |
| Q 1 | 2SJ529S×2 | 2SJ529S×2 | 2SJ529S×2 | 2SJ529S×2 | 2SJ529S×2 | |
| SD1 | RB050L-40×2 | RB050L-40×2 | RB050L-40×2 | RB050L-40×2 | RB050L-40×2 | |
| L1 | 6~11μH±10% | 9~17μH±10% | 10~21μH±10% | 13~26μH±10% | 12~23μH±10% | Rated current |
| | 3.7A or higher | 3.7A or higher | 3.8A or higher | 3.8A or higher | 3.9A or higher | |
| C1 | 1.2Arms or higher | 1.5Arms or higher | 1.8Arms or higher | 2.2Arms or higher | 2.7Arms or higher | Allowable ripple curmt |
| | 470~4700μF | 680~4700μF | 680~4700μF | 1000~4700μF | 1500~4700μF | |
| C2 | 0.8Arms or higher | 0.9Arms or higher | 0.9Arms or higher | 0.9Arms or higher | 1Arms or higher | Allowable ripple curmt |
| | 680~1500μF | 680~1500μF | 680~1500μF | 680~1500μF | 680~1500μF | |
| C3 | 0.1μF/16V (R) | 0.1μF/16V (R) | 0.1μF/16V (R) | 0.1μF/16V (R) | 0.1μF/16V (R) | |
| C4 | 0.1μF/25V (R) | 0.1μF/25V (R) | 0.1μF/25V (R) | 0.1μF/25V (R) | 0.1μF/25V (R) | |
| R1 | 18mΩ±5% less than | 18mΩ±5% less than | 18mΩ±5% less than | 18mΩ±5% less than | 18mΩ±5% less than | |
| R2 | 10kΩ±1% | 10kΩ±1% | 20kΩ±1% | 10kΩ±1% | 3.3kΩ±1% | |
| R3 | 2kΩ±1% | 10kΩ±1% | 33kΩ±1% | 30kΩ±1% | 18kΩ±1% | |

● BP5250-24 external referene components

Input voltage 24V

| Output current | 1A | | | | | Note |
|----------------|-------------------|-------------------|-------------------|-------------------|-------------------|--------------------------|
| Output voltage | 1.5V±3% | 2.5V±3% | 3.3V±3% | 5V±3% | 8V±3% | |
| Q 1 | CPH6306 | CPH6306 | CPH6306 | CPH6306 | CPH6306 | |
| SD1 | RB050L-40 | RB050L-40 | RB050L-40 | RB050L-40 | RB050L-40 | |
| L1 | 18~37μH±10% | 30~59μH±10% | 37~75μH±10% | 52~105μH±10% | 70~140μH±10% | |
| | 1.3A or higher | 1.3A or higher | 1.3A or higher | 1.3A or higher | 1.3A or higher | Rated current |
| C1 | 0.3Arms or higher | 0.4Arms or higher | 0.4Arms or higher | 0.5Arms or higher | 0.7Arms or higher | Allowable ripple current |
| | 33~4700μF | 100~4700μF | 100~4700μF | 100~4700μF | 100~4700μF | |
| C2 | 0.3Arms or higher | 0.3Arms or higher | 0.3Arms or higher | 0.3Arms or higher | 0.3Arms or higher | Allowable ripple current |
| | 220~1000μF | 220~1000μF | 220~1000μF | 220~1000μF | 220~1000μF | |
| C3 | 0.1μF/16V (R) | 0.1μF/16V (R) | 0.1μF/16V (R) | 0.1μF/16V (R) | 0.1μF/16V (R) | |
| C4 | 0.1μF/50V (R) | 0.1μF/50V (R) | 0.1μF/50V (R) | 0.1μF/50V (R) | 0.1μF/50V (R) | |
| R1 | 56mΩ±5% less than | 56mΩ±5% less than | 56mΩ±5% less than | 56mΩ±5% less than | 56mΩ±5% less than | |
| R2 | 10kΩ±1% | 10kΩ±1% | 20kΩ±1% | 10kΩ±1% | 3.3kΩ±1% | |
| R3 | 2kΩ±1% | 10kΩ±1% | 33kΩ±1% | 30kΩ±1% | 18kΩ±1% | |

| Output current | 2A | | | | | Note |
|----------------|-------------------|-------------------|-------------------|-------------------|-------------------|--------------------------|
| Output voltage | 1.5V±3% | 2.5V±3% | 3.3V±3% | 5V±3% | 8V±3% | |
| Q 1 | 2SJ529S | 2SJ529S | 2SJ529S | 2SJ529S | 2SJ529S | |
| SD1 | RB050L-40 | RB050L-40 | RB050L-40 | RB050L-40 | RB050L-40 | |
| L1 | 9~18μH±10% | 15~30μH±10% | 19~38μH±10% | 26~52μH±10% | 35~70μH±10% | |
| | 2.5A or higher | 2.5A or higher | 2.5A or higher | 2.5A or higher | 2.5A or higher | Rated current |
| C1 | 0.6Arms or higher | 0.7Arms or higher | 0.8Arms or higher | 1Arms or higher | 1.3Arms or higher | Allowable ripple current |
| | 100~4700μF | 100~4700μF | 220~4700μF | 220~4700μF | 220~4700μF | |
| C2 | 0.6Arms or higher | 0.6Arms or higher | 0.6Arms or higher | 0.6Arms or higher | 0.6Arms or higher | Allowable ripple current |
| | 560~1500μF | 560~1500μF | 560~1500μF | 560~1500μF | 560~1500μF | |
| C3 | 0.1μF/16V (R) | 0.1μF/16V (R) | 0.1μF/16V (R) | 0.1μF/16V (R) | 0.1μF/16V (R) | |
| C4 | 0.1μF/50V (R) | 0.1μF/50V (R) | 0.1μF/50V (R) | 0.1μF/50V (R) | 0.1μF/50V (R) | |
| R1 | 27mΩ±5% less than | 27mΩ±5% less than | 27mΩ±5% less than | 27mΩ±5% less than | 27mΩ±5% less than | |
| R2 | 10kΩ±1% | 10kΩ±1% | 20kΩ±1% | 10kΩ±1% | 3.3kΩ±1% | |
| R3 | 2kΩ±1% | 10kΩ±1% | 33kΩ±1% | 30kΩ±1% | 18kΩ±1% | |

| Output current | 3A | | | | | Note |
|----------------|-------------------|-------------------|-------------------|-------------------|-------------------|--------------------------|
| Output voltage | 1.5V±3% | 2.5V±3% | 3.3V±3% | 5V±3% | 8V±3% | |
| Q 1 | 2SJ529S×2 | 2SJ529S×2 | 2SJ529S×2 | 2SJ529S×2 | 2SJ529S×2 | |
| SD1 | RB050L-40×2 | RB050L-40×2 | RB050L-40×2 | RB050L-40×2 | RB050L-40×2 | |
| L1 | 6~12μH±10% | 10~20μH±10% | 13~25μH±10% | 17~35μH±10% | 23~47μH±10% | |
| | 3.8A or higher | 3.8A or higher | 3.8A or higher | 3.8A or higher | 3.8A or higher | Rated current |
| C1 | 0.9Arms or higher | 1Arms or higher | 1.2Arms or higher | 1.5Arms or higher | 1.9Arms or higher | Allowable ripple current |
| | 220~4700μF | 220~4700μF | 220~4700μF | 470~4700μF | 470~4700μF | |
| C2 | 0.9Arms or higher | 0.9Arms or higher | 0.9Arms or higher | 0.9Arms or higher | 0.9Arms or higher | Allowable ripple current |
| | 680~1500μF | 680~1500μF | 680~1500μF | 680~1500μF | 680~1500μF | |
| C3 | 0.1μF/16V (R) | 0.1μF/16V (R) | 0.1μF/16V (R) | 0.1μF/16V (R) | 0.1μF/16V (R) | |
| C4 | 0.1μF/25V (R) | 0.1μF/25V (R) | 0.1μF/25V (R) | 0.1μF/25V (R) | 0.1μF/25V (R) | |
| R1 | 18mΩ±5% less than | 18mΩ±5% less than | 18mΩ±5% less than | 18mΩ±5% less than | 18mΩ±5% less than | |
| R2 | 10kΩ±1% | 10kΩ±1% | 20kΩ±1% | 10kΩ±1% | 3.3kΩ±1% | |
| R3 | 2kΩ±1% | 10kΩ±1% | 33kΩ±1% | 30kΩ±1% | 18kΩ±1% | |

Precautions on Use of ROHM Power Module

Safety Precautions

- 1) The products are designed and produced for application in ordinary electronic equipment (AV equipment, OA equipment, telecommunication equipment, home appliances, amusement equipment etc.).
If the products are to be used in devices requiring extremely high reliability (medical equipment, transport equipment, aircraft/spacecraft, nuclear power controllers, fuel controllers, car equipment including car accessories, safety devices, etc.) and whose malfunction or operational error may endanger human life and sufficient fail-safe measures, please consult with the Company's sales staff in advance. If product malfunctions may result in serious damage, including that to human life, sufficient fail-safe measures must be taken, including the following:
 - [a] Installation of protection circuits or other protective devices to improve system safety
 - [b] Installation of redundant circuits in the case of single-circuit failure
- 2) The products are designed for use in a standard environment and not in any special environments. Application of the products in a special environment can deteriorate product performance. Accordingly, verification and confirmation of product performance, prior to use, is recommended if used under the following conditions:
 - [a] Use in various types of liquid, including water, oils, chemicals, and organic solvents
 - [b] Use outdoors where the products are exposed to direct sunlight, or in dusty places
 - [c] Use in places where the products are exposed to sea winds or corrosive gases, including Cl₂, H₂S, NH₃, SO₂, and NO₂
 - [d] Use in places where the products are exposed to static electricity or electromagnetic waves
 - [e] Use in proximity to heat-producing components, plastic cords, or other flammable items
 - [f] Use involving sealing or coating the products with resin or other coating materials
 - [g] Use involving unclean solder or use of water or water-soluble cleaning agents for cleaning after soldering
 - [h] Use of the products in places subject to dew condensation
- 3) The products are not radiation resistant.
- 4) The Company is not responsible for any problems resulting from use of the products under conditions not recommended herein.
- 5) The Company should be notified of any product safety issues. Moreover, product safety issues should be periodically monitored by the customer.

Precautions Regarding Application Example and External Circuits



- 1) If change is made to the constant of an external circuit, allow a sufficient margin due to variations of the characteristics of the products and external components, including transient characteristics, as well as static characteristics. Please be informed that the Company has not conducted investigations on whether or not particular changes in the application examples or external circuits would result in the infringement of patent rights of a third party.
- 2) The application examples, their constants, and other types of information contained herein are applicable only when the products are used in accordance with standard methods.
Therefore, if mass production is intended, sufficient consideration to external conditions must be made.

Prohibitions Regarding Industrial Property

- 1) These Specifications contain information related to the Company's industrial property. Any use of them other than pertaining to the usage of appropriate products is not permitted. Duplication of these Specifications and its disclosure to a third party without the Company's permission is prohibited.
- 2) Information and data on products, including application examples, contained in these specifications are simply for reference; the Company does not guarantee any industrial property rights, intellectual property rights, or any other rights of a third party regarding this information or data. Accordingly, the Company does not bear any responsibility for:
 - [a] infringement of the intellectual property rights of a third party
 - [b] any problems incurred by the use of the products listed herein.
- 3) The Company prohibits the purchaser of its products to exercise or use the intellectual property rights, industrial property rights, or any other rights that either belong to or are controlled by the Company, other than the right to use, sell, or dispose of the products.

Looking for pricing, stock, or lifecycle information?

Click below to explore more details on WIN SOURCE:

-  [View BP5250-24](#) on WIN SOURCE
-  [Rohm Semiconductor](#) Information

Optimize Your Supply Chain with WIN SOURCE Solutions

-  Global Sourcing Solution
-  Obsolete Management
-  Cost Control Management
-  Shortage Management
-  Alternative Solution
-  Excess Inventory Management