



**THE DATASHEET OF
BQ25892EVM-664**



bq25890EVM, bq25892EVM, bq25895EVM, bq25896EVM and bq25895MEVM(PWR664)

This user's guide provides detailed testing instructions for the PWR664 evaluation modules (EVM) using the bq25890, bq25892, bq25895, bq25896 or bq25895M (bq2589x) devices. Also included are descriptions of the necessary equipment, equipment setup, and procedures. The reference documentation contains the printed-circuit board layouts, schematics, and the bill of materials (BOM).

Contents

1	Introduction	2
	1.1 EVM Features	2
	1.2 I/O Descriptions	2
2	Test Summary	4
	2.1 Equipment	4
	2.2 Equipment Setup.....	5
	2.3 Procedure	9
3	PCB Layout Guideline	11
4	Board Layout, Schematic, and Bill of Materials	12
	4.1 PWR664 PCB Layouts	12
	4.2 Schematics	16
	4.3 Bill of Materials	21

List of Figures

1	Verify Windows 7 Properties	4
2	Connections of the EV2300	5
3	Original Test Setup for PWR664 (bq2589x EVM).....	5
4	Start Window of the bq2589x Evaluation Software	6
5	Part Select Window of the bq2589x Evaluation Software	6
6	Communications Adapter Error	7
7	Acknowledge Error	7
8	DashBoard Status Tab.....	7
9	Select Field View	8
10	Main Window of the bq2589x Evaluation Software	8
11	Top Assembly.....	12
12	Top Layer	13
13	Mid-Layer 1	13
14	Mid-Layer 2	14
15	Bottom Layer.....	14
16	Bottom Solder.....	15
17	Bottom Assembly	15
18	bq25890 EVM Schematic	16
19	bq25892 EVM Schematic	17
20	bq25895 EVM Schematic	18
21	bq25895M EVM Schematic.....	19
22	bq25896 EVM Schematic	20

List of Tables

1	Device Data Sheets	2
2	EVM Connections.....	2
3	Jumper Connections	3
4	Recommended Operating Conditions.....	3
5	bq25890EVM-664 Bill of Materials.....	21
6	bq25892EVM-664 Bill of Materials.....	23
7	bq25895EVM-664 Bill of Materials.....	25
8	bq25895MEVM-664 Bill of Materials	27
9	bq25896EVM-664 Bill of Materials.....	29

Trademarks

Microsoft, Windows are registered trademarks of Microsoft Corporation.

1 Introduction

1.1 EVM Features

For detailed features and operation, refer to [Table 1](#) for a list of devices and their data sheets.

Table 1. Device Data Sheets

Device	Document
bq25890, bq25892	SLUSC86
bq25895	SLUSC88
bq25895M	SLUSCC8
bq25896	SLUSC76

The bq2589x evaluation module (EVM) is a complete charger modules for evaluating an I²C-controlled single NVDC-1 charge using the bq2589x device.

This EVM doesn't include the USB-to-GPIO interface board. To evaluate the EVM, a USB-to-GPIO interface board must be ordered separately.

1.2 I/O Descriptions

[Table 2](#) lists the jumper connections available on this EVM.

Table 2. EVM Connections

Jack	Description
J1-VBUS	Input: positive terminal
J1-GND	Input: negative terminal (ground terminal)
J2-PMID	PMID pin connection/Power bank output
J2-GND	Ground/Power bank output negative terminal
J3-SYS	Connected to system
J3-GND	Ground
J4-BAT+	Connected to battery pack
J4-GND	Ground
J5	Input mini-USB port
J6	Output mini-USB port
J7	USB-to-GPIO connector
J8	I2C 4-pin connector

Table 3 lists the EVM jumper connections.

Table 3. Jumper Connections

Jack	Description	Factory Setting
JP1	For bq25892/6 input current setting: Low: adaptor port; High: USB input	bq25890/5/5M: Not installed; bq25892/6: short PSEL to LOW
JP2	D-/PG pin selection	bq25890/5/5M: short to D-; bq25892/6: short to PG
JP3	Pin 24 selection: to DSEL, PG, or NC	bq25890/5/5M_DSEL: short to DSEL; bq25892/6: not installed
JP4	STAT, PG, \overline{CE} , INT, OTG pins internal pullup source (VSYS or BAT)	Short to VSYS
JP5	D+/D- connections for input current limit setting	bq25890/5/5M: installed; bq25892/6: Not installed
JP6	USB current limit selection pin during buck mode and PSEL is high/ Enable pin during boost mode	Not installed
JP7	\overline{CE} pin setting: pull low to enable the charge	Not Installed
JP8	TS pin to GND	Not Installed
JP9	TS resistor divider pullup source (REGN) connection	Installed
JP10	Internal 10 k to GND to TS pin	Installed

Table 4 lists the recommended operating conditions for this EVM.

Table 4. Recommended Operating Conditions

Symbol	Description	MIN	TYP	MAX	Unit
Supply voltage, V_{IN} bq25890/2/5/5M/6	Input voltage from AC adapter	3.9		14	V
Battery voltage, V_{BAT} 0 3.7 4.4 V	Voltage applied at V_{BAT} terminal	0		4.5	V
I_{BAT}	Fast charging current			5	A
	Discharging current through internal MOSFET	9			A
Supply current, I_{IN}	Maximum input current from AC adapter input	0		3.25	A

2 Test Summary

2.1 Equipment

This section includes a list of supplies required to perform tests on this EVM.

1. Power Supplies

Power supply #1 (PS#1): a power supply capable of supplying 5 V at 1 A is required. While this part can handle larger voltage and current, it is not necessary for this procedure.

2. Load #1 (4-Quadrant Supply, Constant Voltage < 4.5 V)

A 0–20 V/0–5 A, > 30-W system, DC electronic load and setting as constant voltage load mode.

Or:

Kepeco load: BOP 20–5M, DC 0 to ±20 V, 0 to ±5 A (or higher).

3. Load #2 – Use with Boost Mode

PMID to GND load, 10 Ω, 5 W or greater.

4. Meters

Six Fluke 75 multimeters, (equivalent or better).

Or:

Four equivalent voltage meters and two equivalent current meters. The current meters must be capable of measuring 5 A+ current.

5. Computer

A computer with at least one USB port and a USB cable. The bq2589xEVM evaluation software must be properly installed.

6. USB-to-GPIO Communication Kit (EV2300 USB-Based PC Interface Board)

7. Software

Double click the “BatteryManagementStudio-1.3.35_Build2-windows-installer” installation file, follow the installation steps. The software supports the Microsoft® Windows® XP and Windows 7 operating systems.

Install EV2300 Software

For Windows 7 64-bit users:

http://e2e.ti.com/support/power_management/battery_management/m/videos__files/458983.aspx.

Verify the computer Windows 7 settings by right clicking on computer and selecting properties:

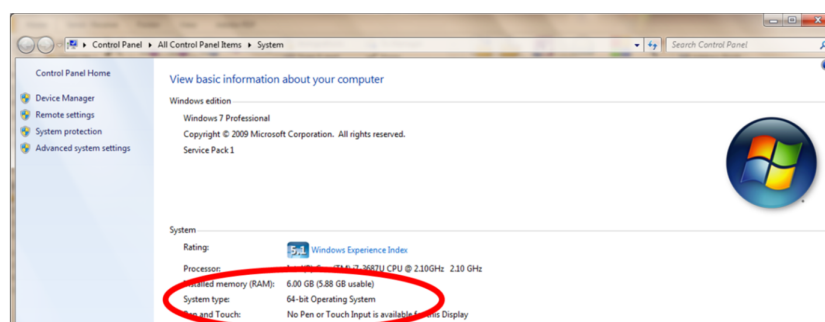

Figure 1. Verify Windows 7 Properties

Windows XP or Windows 7 32-bit users must access the following: <http://www.ti.com/litv/zip/slec003a>.

2.2 Equipment Setup

1. Set PS#1 for 5-V DC, 1-A current limit and then turn off the supply.
2. Connect the output of PS#1 in series with a current meter (multimeter) to J1 (VBUS and GND).
3. Connect a voltage meter across TP3 (VBUS) and TP6 (PGND).
4. Turn on the Load, set to constant voltage mode and output to 2.5 V. Turn off (disable) Load. Connect Load in series with a current meter (multimeter), ground side, to J4 (BAT+ and GND) as shown in Figure 3.
5. Connect a voltage meter across J4 (BAT+ and GND).
6. Connect the EV2300 USB interface board to the computer with a USB cable and from I2C port to J8 with the 4-pin cable. The connections are shown in Figure 2.
7. Remove jumper (if installed) from JP5.

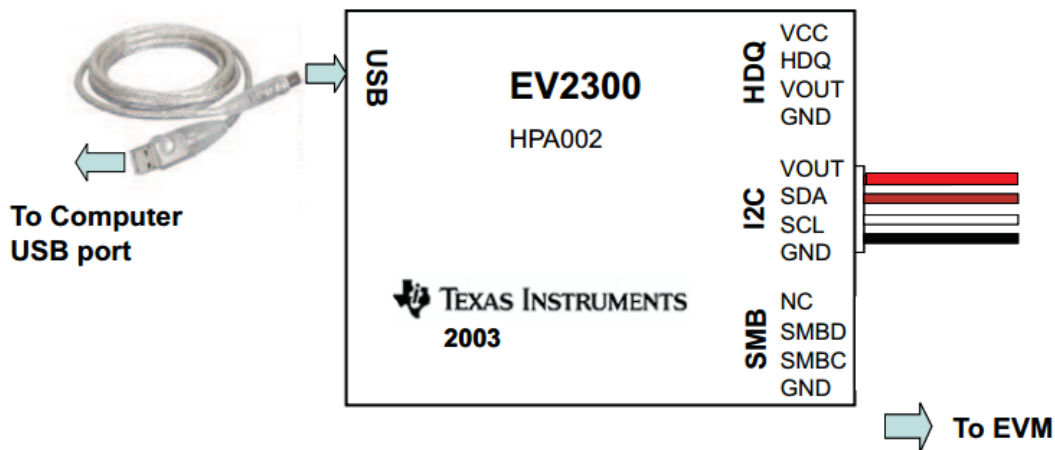

Figure 2. Connections of the EV2300

8. Install shunts as shown in Table 3.

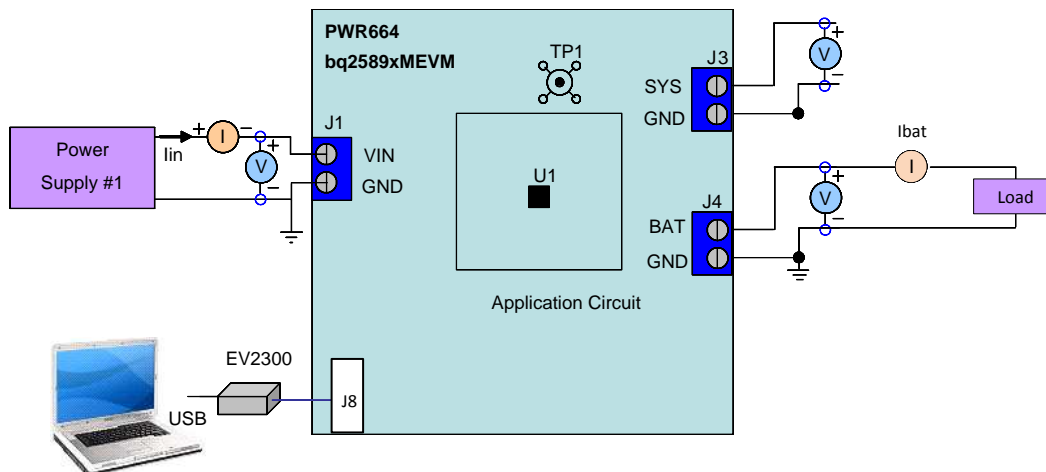

Figure 3. Original Test Setup for PWR664 (bq2589x EVM)

- Turn on the computer. Launch the bq2589x evaluation software, choose *Charger* as shown in [Figure 4](#), then choose the appropriate .bqz file as shown in [Figure 5](#).

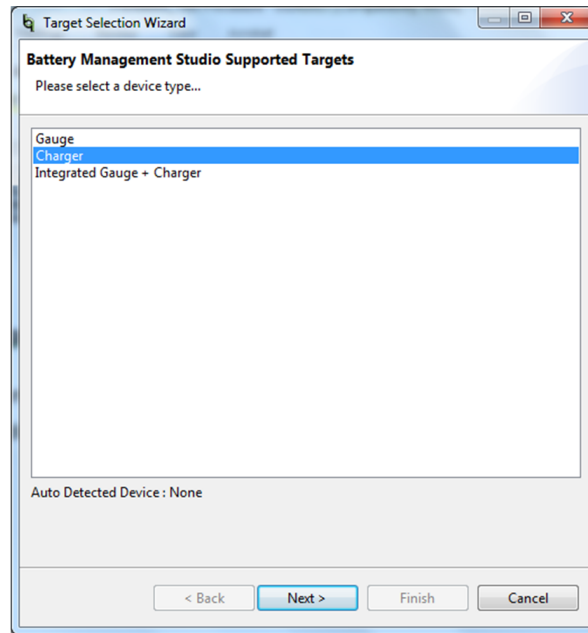

Figure 4. Start Window of the bq2589x Evaluation Software

[Figure 5](#) illustrates the following part selection options:

- Select the Charger_1_00-bq25890-895.bqz file, if evaluating the bq25890 or bq25895
- Select Charger_1_00-bq25892-896.bqz, if evaluating the bq25892

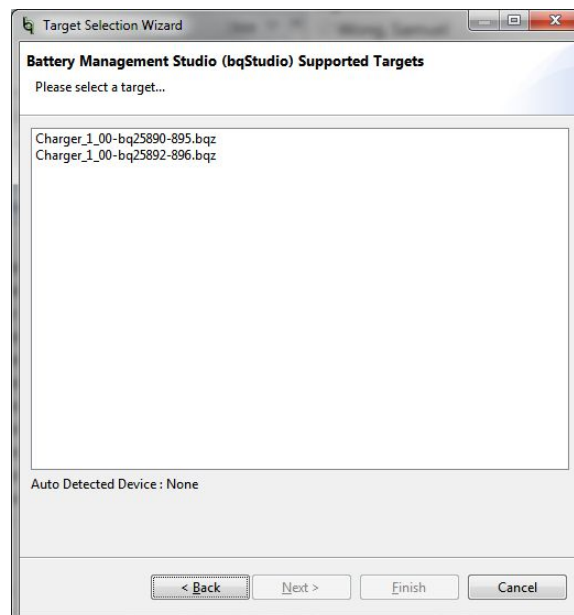

Figure 5. Part Select Window of the bq2589x Evaluation Software

10. If an error pops up stating the communications adapter was not found (Figure 6), click OK to proceed. Next, unplug and re-plug the adapter.

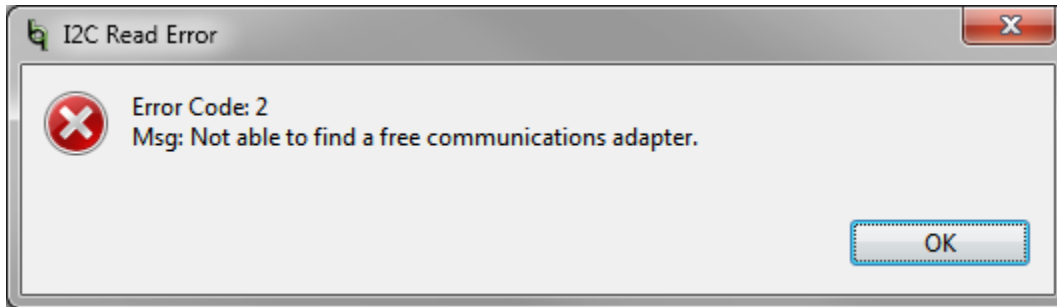

Figure 6. Communications Adapter Error

If an error pops up stating there is no acknowledge from the device (Figure 7), click OK to proceed and then pick the appropriate I2C address from the drop-down menu in the GUI (see the Procedure section).

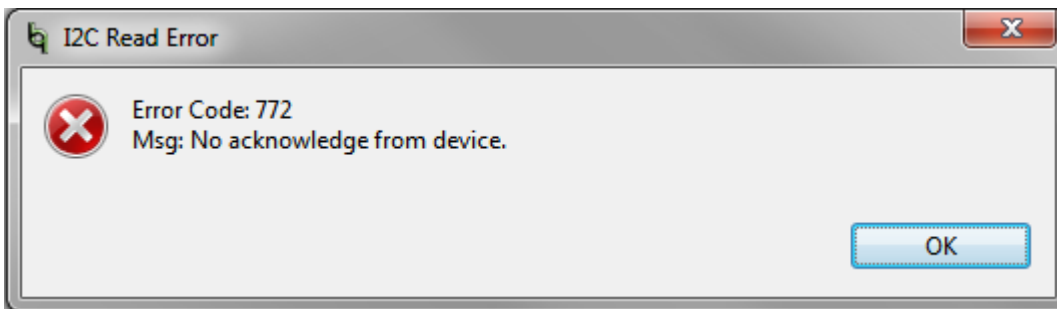

Figure 7. Acknowledge Error

Check the connection status of the EV2300 in bqStudio by going to *View* → *DashBoard*. A panel on the left-hand side should appear, with the status of the EV2300 at the top (Figure 8).

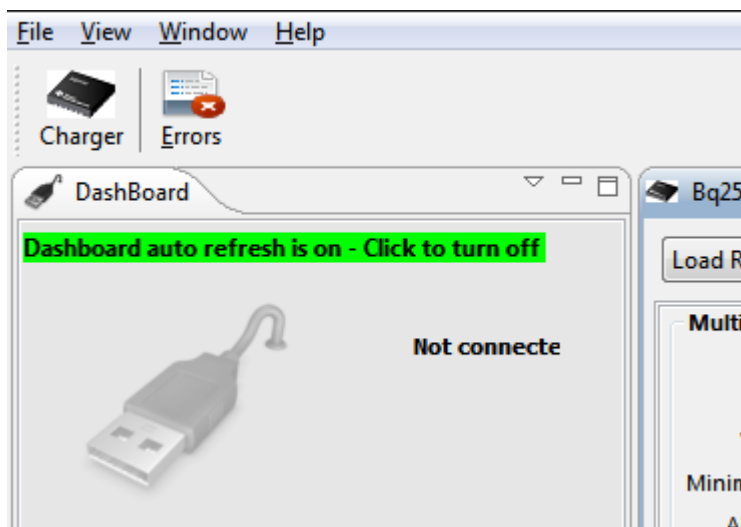

Figure 8. DashBoard Status Tab

- Choose *Field View*, as shown in Figure 9. The main window of the bq2589x software is shown in Figure 10.

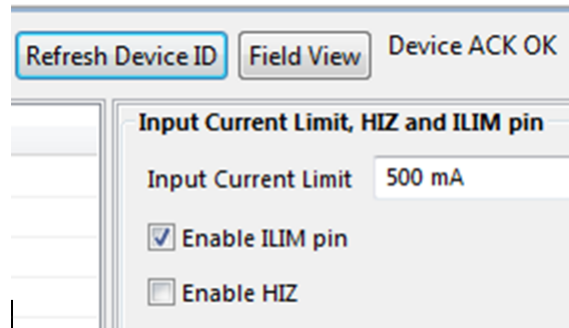

Figure 9. Select Field View

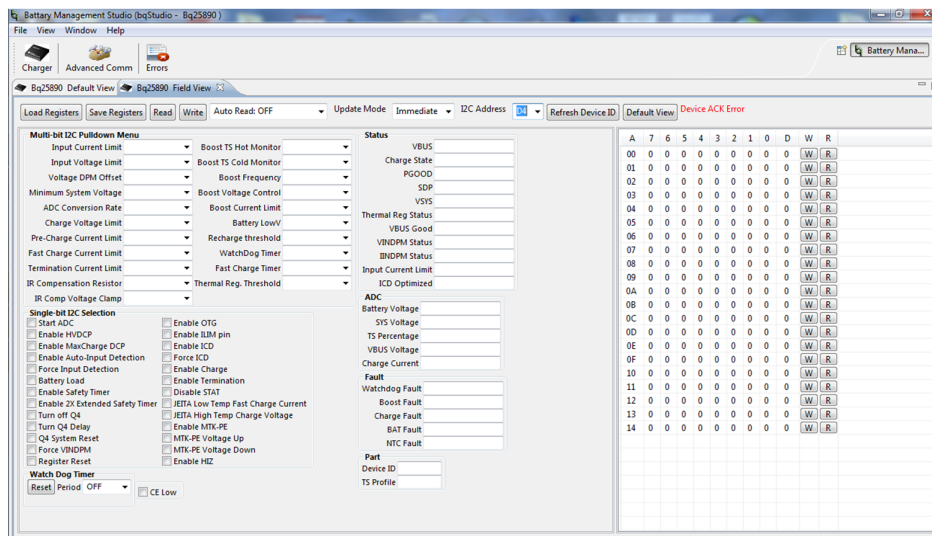
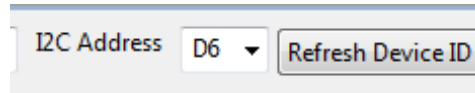

Figure 10. Main Window of the bq2589x Evaluation Software

2.3 Procedure

2.3.1 Communication Verification

1. In the EVM software, specify device "I2C Address" as D6 for bq25892/6, and D4 for bq25890/5.



2. Enable Load#1 from [Section 2.2](#), step 4. Click the **Read** button
3. In the EVM GUI software (see example screen shot below) , make the following changes as necessary:
 - Select "Disabled" for the "Watchdog Timer"
 - Select "Force VINDPM"
 - Set "Input Voltage Limit" to 4.2
 - Set "Input Current Limit" to 500 mA
 - Set "Charge Voltage Limit" to 4.208 V
 - Set "Fast Charge Current" ICHG to 960 mA
 - Set "Minimum System Voltage" to 3.5V
 - Set "Pre-Charge Current" to 256 mA
 - Select "Charge Enable"
 - Deselect "Enable ILIM pin"
 - Deselect "Enable ICD"
 - Deselect "Enable Termination"

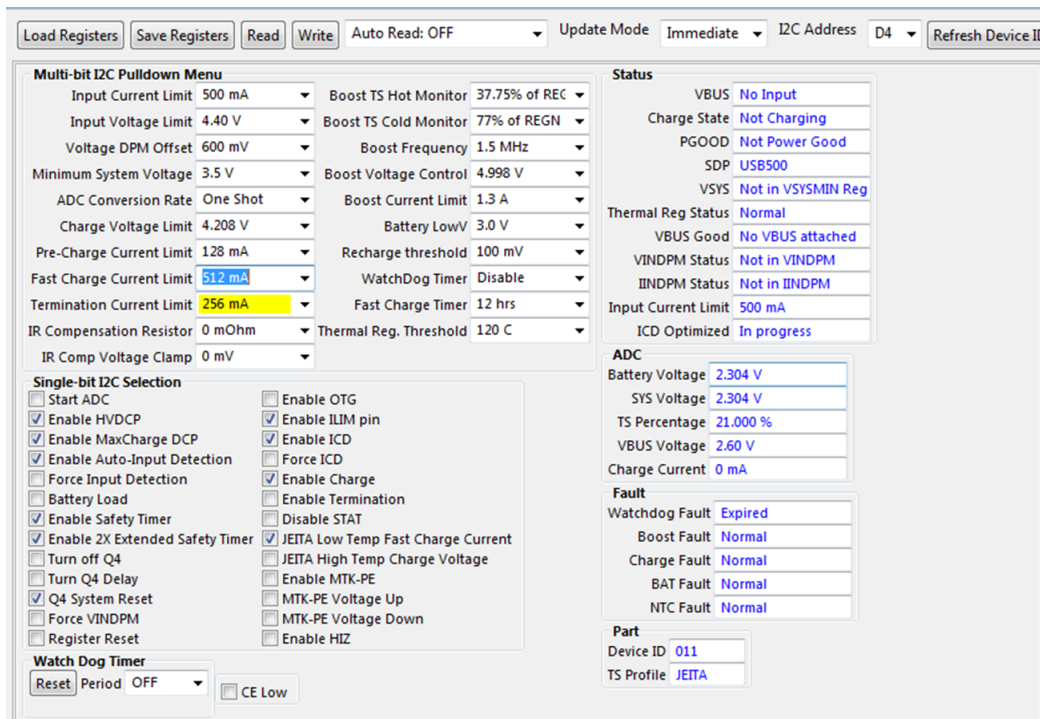

The screenshot shows the EVM GUI software interface. At the top, there are buttons for 'Load Registers', 'Save Registers', 'Read', and 'Write'. The 'Auto Read' is set to 'OFF' and 'Update Mode' is 'Immediate'. The 'I2C Address' is set to 'D4' and there is a 'Refresh Device ID' button.

The main area is divided into several sections:

- Multi-bit I2C Pulldown Menu:** Contains various settings such as Input Current Limit (500 mA), Input Voltage Limit (4.40 V), Voltage DPM Offset (600 mV), Minimum System Voltage (3.5 V), ADC Conversion Rate (One Shot), Charge Voltage Limit (4.208 V), Pre-Charge Current Limit (128 mA), Fast Charge Current Limit (512 mA), Termination Current Limit (256 mA), IR Compensation Resistor (0 mOhm), IR Comp Voltage Clamp (0 mV), Boost TS Hot Monitor (37.75% of REC), Boost TS Cold Monitor (77% of REGN), Boost Frequency (1.5 MHz), Boost Voltage Control (4.998 V), Boost Current Limit (1.3 A), Battery LowV (3.0 V), Recharge threshold (100 mV), WatchDog Timer (Disable), Fast Charge Timer (12 hrs), and Thermal Reg. Threshold (120 C).
- Single-bit I2C Selection:** Contains checkboxes for Start ADC, Enable HVDCP, Enable MaxCharge DCP, Enable Auto-Input Detection, Force Input Detection, Battery Load, Enable Safety Timer, Enable 2X Extended Safety Timer, Turn off Q4, Turn Q4 Delay, Q4 System Reset, Force VINDPM, Register Reset, Enable OTG, Enable ILIM pin, Enable ICD, Force ICD, Enable Charge, Enable Termination, Disable STAT, JEITA Low Temp Fast Charge Current, JEITA High Temp Charge Voltage, Enable MTK-PE, MTK-PE Voltage Up, MTK-PE Voltage Down, and Enable HIZ.
- Watch Dog Timer:** Set to 'Reset' with 'Period' 'OFF' and 'CE Low' checked.
- Status:** Shows various status indicators such as VBUS (No Input), Charge State (Not Charging), PGOOD (Not Power Good), SDP (USB500), VSYS (Not in VSYSMIN Reg), Thermal Reg Status (Normal), VBUS Good (No VBUS attached), VINDPM Status (Not in VINDPM), IINDPM Status (Not in IINDPM), Input Current Limit (500 mA), and ICD Optimized (In progress).
- ADC:** Shows Battery Voltage (2.304 V), SYS Voltage (2.304 V), TS Percentage (21.000 %), VBUS Voltage (2.60 V), and Charge Current (0 mA).
- Fault:** Shows Watchdog Fault (Expired), Boost Fault (Normal), Charge Fault (Normal), BAT Fault (Normal), and NTC Fault (Normal).
- Part:** Shows Device ID (011) and TS Profile (JEITA).

2.3.2 Charger Mode Verification

- Turn on PS#1, click the **Read** button twice:
 - Observe** → Everything *Normal* at *Fault* box

Fault	
Watchdog Fault	Normal
Boost Fault	Normal
Charge Fault	Normal
BAT Fault	Normal
NTC Fault	Normal

- Observe** → D3 (STAT) is on
 - Observe** → D4 (\overline{PG}) is on (bq25892/6)
- Measure the voltage across J3 and J4 as follows:
 - Measure** → V(TP4(SYS), TP7(GND)) = 3.65 V \pm 300 mV
 - Measure** → V(TP5(BAT), TP7(GND)) = 2.5 V \pm 200 mV
 - Change load to 3.7 V
 - Measure** → I(BAT) = 625 mA \pm 100 mA
 - Measure** → V(TP5(BAT), TP7(GND)) = 3.7 V \pm 200 mV
 - Measure** → I(VBUS) = 500 mA \pm 200mA

2.3.3 Boost Mode Verification

- Turn off and disconnect PS#1
- If the constant voltage load connected from BAT+ to GND is not a four-quadrant supply (sources current), remove the load and use the power source disconnected in step one, set to 3.7-V and 2-A current limit and connect between BAT+ and GND
- Check the *OTG* configurations option in the GUI

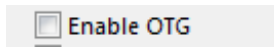

- Apply 10 Ω (5 W or greater) across J2 (PMID(+)) to GND(-)
 - Measure: V:** (TP2 (PMID) and TP6 (GND)) = 5.0 V \pm 200 mV

2.3.4 Helpful Hints

- The leads/cables to the various power supplies, batteries and loads have resistance. The current meters also have series resistance. The charger dynamically reduces charge current depending on the voltage sensed at its VBUS pin (using the VINDPM feature), BAT pin (as part of normal termination) and TS pin (through its battery temperature monitoring feature via battery thermistor). Therefore, you must use voltmeters to measure the voltage as close to the IC pins as possible instead of relying on the power supply's digital readouts. If a battery thermistor is not available, either disable the TS function or replace with an appropriately sized (typically) 10 k Ω resistor.
- When using a sourcemeter that can source and sink current as your battery simulator, it is highly recommended to add a large (1000 μ F+) capacitor at the EVM BAT and GND connectors in order to prevent oscillations at the BAT pin due to mismatched impedances of the charger output and sourcemeter input within their respective regulation loop bandwidths. Configuring the sourcemeter for 4-wire sensing eliminates the need for a separate voltmeter to measure the voltage at the BAT pin. When using 4-wire sensing, always ensure that the sensing leads are connected in order to prevent accidental overvoltage by the power leads.
- For precise measurements of charge current and battery regulation near termination, the current meter

in series with the battery or battery simulator should not be set to auto-range and may need be removed entirely. An alternate method for measuring charge current is to either use an oscilloscope with hall effect current probe or place a 1% or better, thermally capable (for example, 0.010 Ω in 1210 or larger footprint) resistor in series between the BAT pin and battery and measure the voltage across that resistor.

3 PCB Layout Guideline

Minimize the switching node rise and fall times for minimum switching loss. Proper layout of the components minimizing high-frequency current path loop is important to prevent electrical and magnetic field radiation and high-frequency resonant problems. This PCB layout priority list must be followed in the order presented for proper layout:

1. Place the input capacitor as close as possible to the PMID and GND pin connections and use the shortest possible copper trace connection or GND plane.
2. Place the inductor input terminal as close to the SW pin as possible. Minimize the copper area of this trace to lower electrical and magnetic field radiation but make the trace wide enough to carry the charging current. Do not use multiple layers in parallel for this connection. Minimize parasitic capacitance from this area to any other trace or plane.
3. Put an output capacitor near to the inductor and the IC. Tie ground connections to the IC ground with a short copper trace connection or GND plane.
4. Route analog ground separately from power ground. Connect analog ground and connect power ground separately. Connect analog ground and power ground together using power pad as the single ground connection point or use a 0- Ω resistor to tie analog ground to power ground.
5. Use a single ground connection to tie the charger power ground to the charger analog ground just beneath the IC. Use ground copper pour but avoid power pins to reduce inductive and capacitive noise coupling.
6. Place decoupling capacitors next to the IC pins and make the trace connection as short as possible.
7. It is critical that the exposed power pad on the backside of the IC package be soldered to the PCB ground. Ensure that there are sufficient thermal vias directly under the IC, connecting to the ground plane on the other layers.
8. The via size and number should be enough for a given current path.

See the EVM design for the recommended component placement with trace and via locations. For the QFN information, refer to *Quad Flatpack No-Lead Logic Packages (SCBA017)* and *QFN/SON PCB Attachment (SLUA271)*.

4 Board Layout, Schematic, and Bill of Materials

This section contains the [board layouts](#), [schematics](#), and [BOM](#).

4.1 PWR664 PCB Layouts

Figure 11 through Figure 17 show the PCB layouts for the PWR664 EVM.

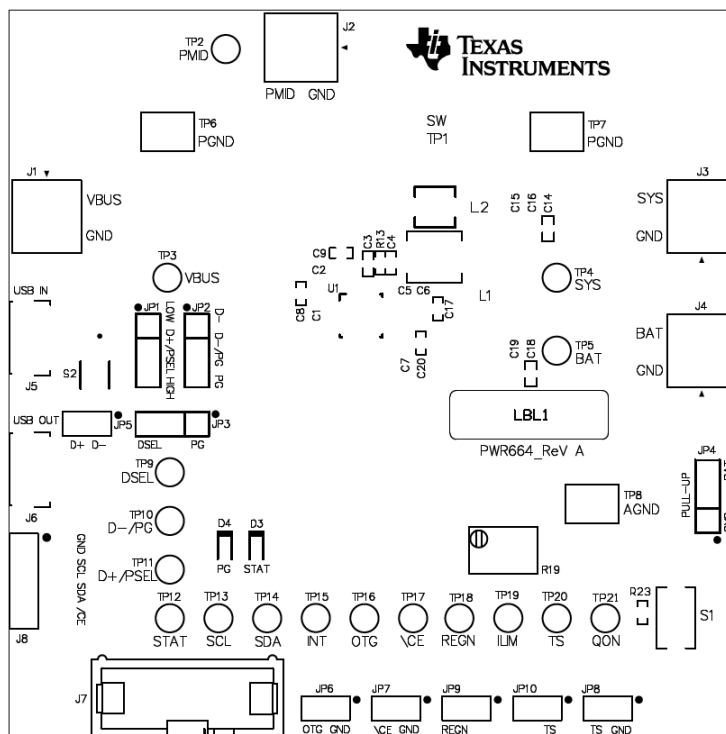

Figure 11. Top Assembly

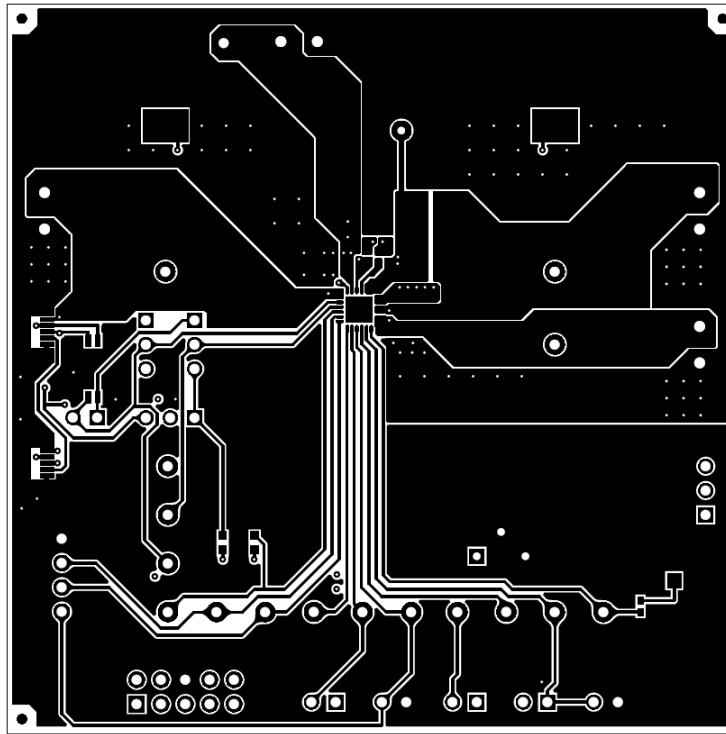

Figure 12. Top Layer

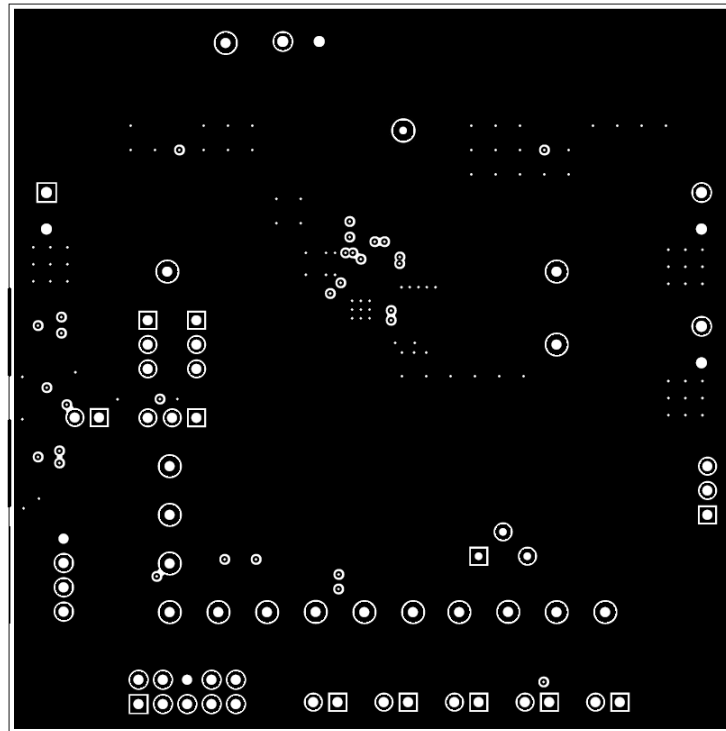

Figure 13. Mid-Layer 1

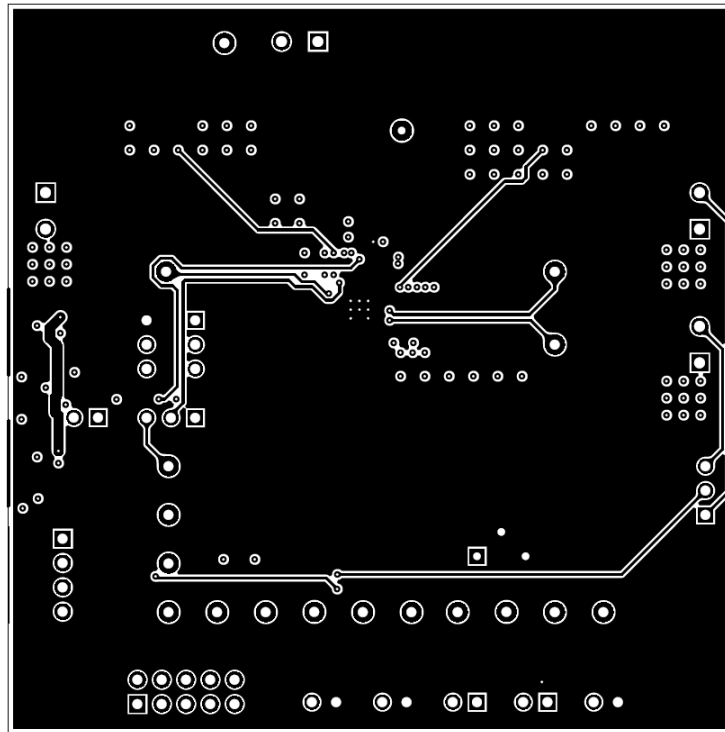

Figure 14. Mid-Layer 2

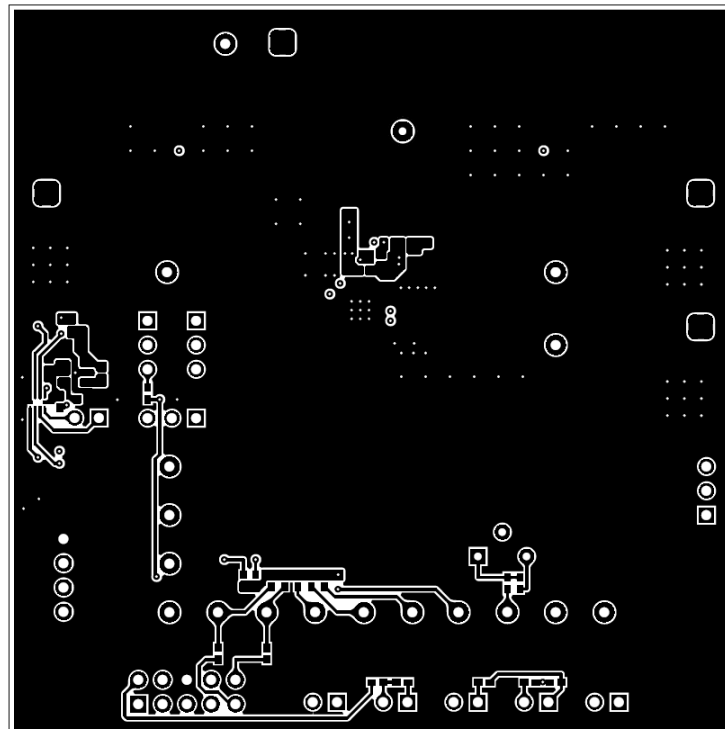

Figure 15. Bottom Layer

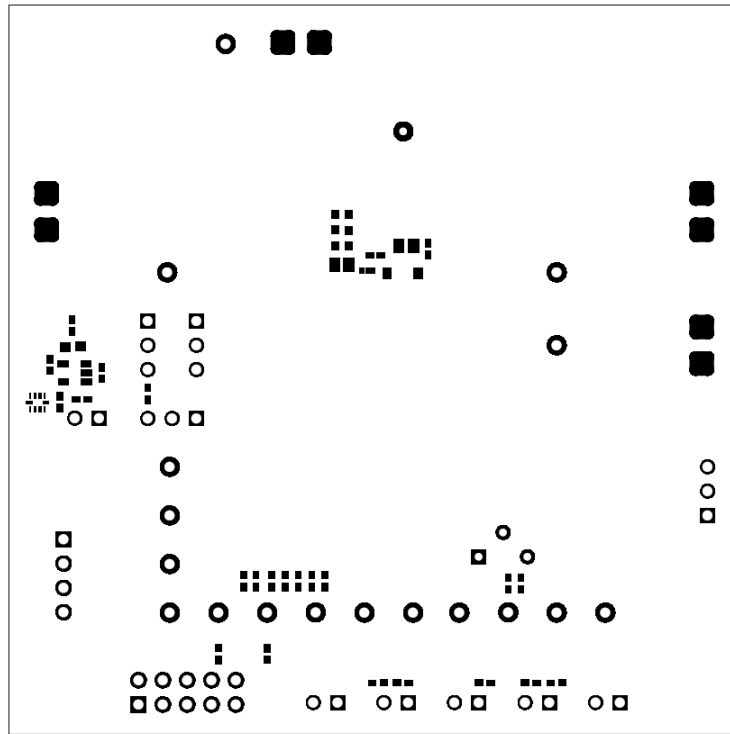
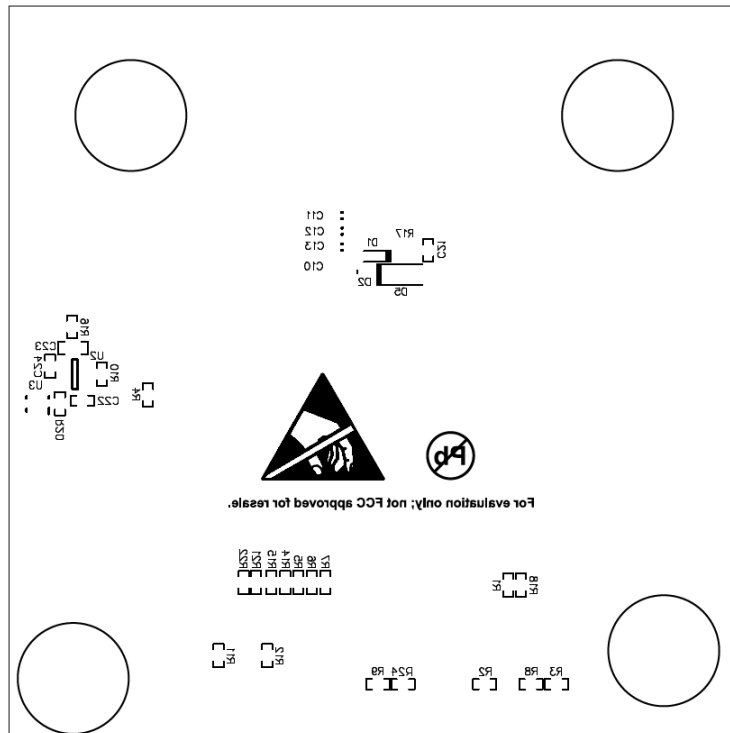
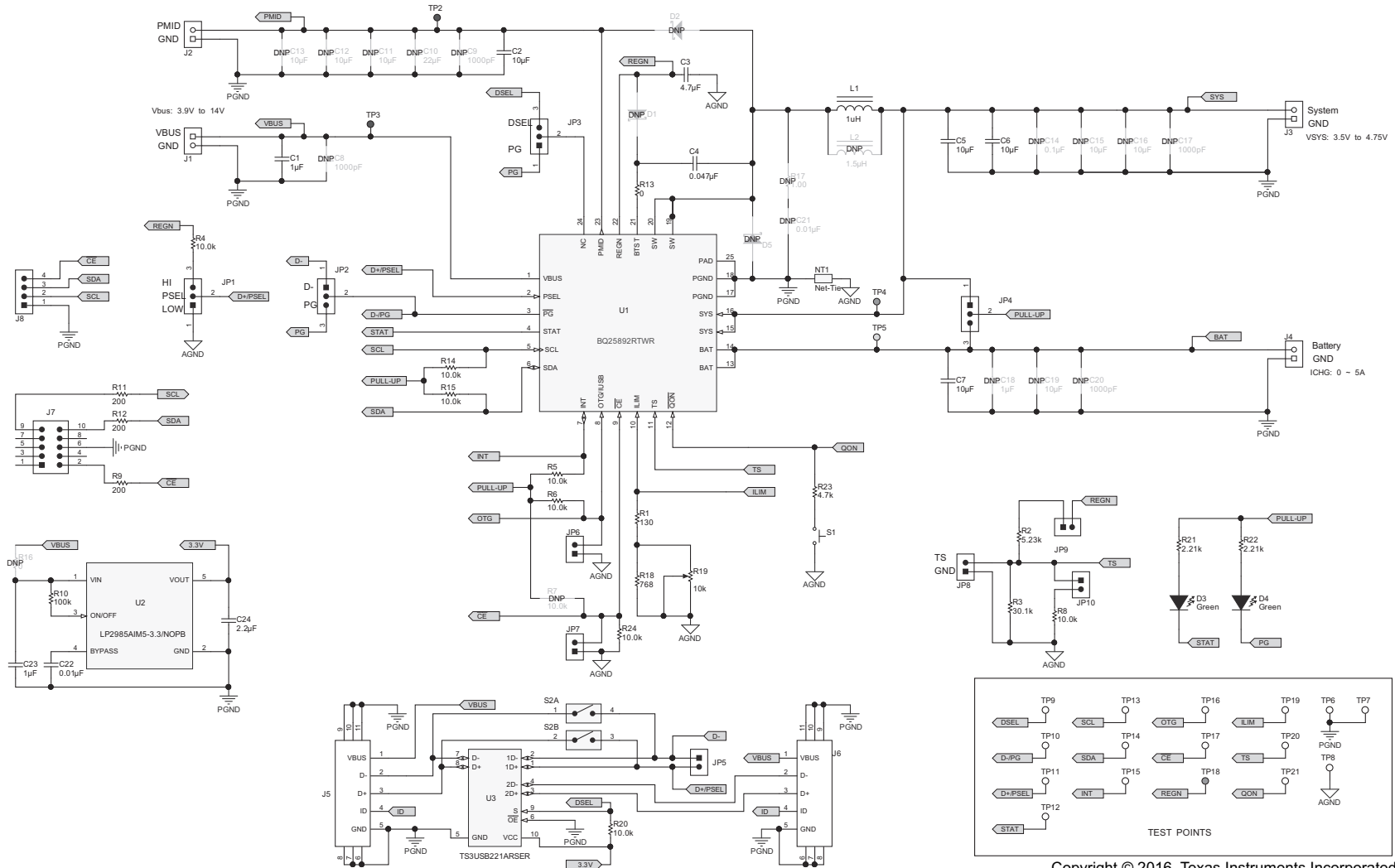

Figure 16. Bottom Solder





Copyright © 2016, Texas Instruments Incorporated

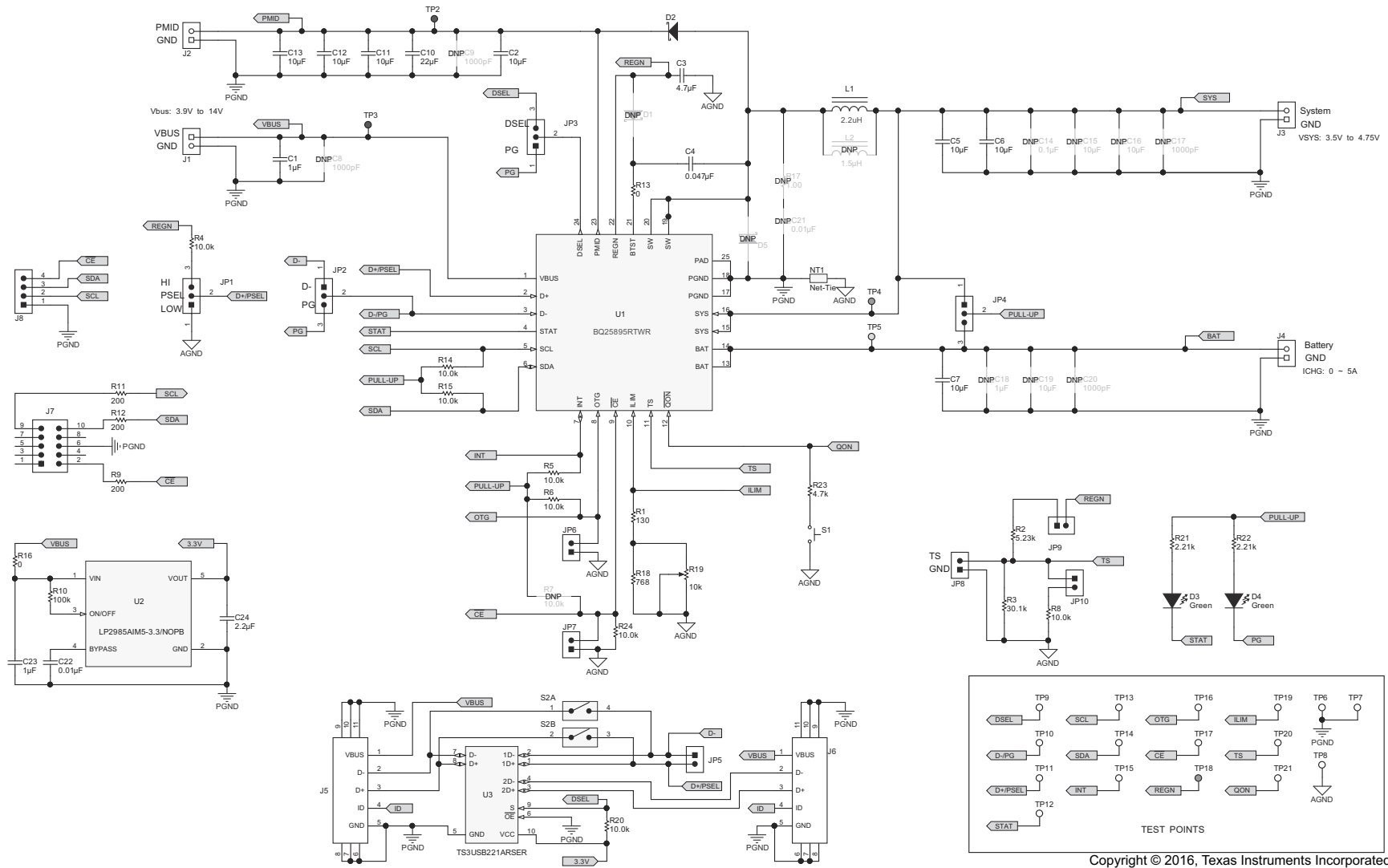

Figure 20. bq25895 EVM Schematic

Copyright © 2016, Texas Instruments Incorporated

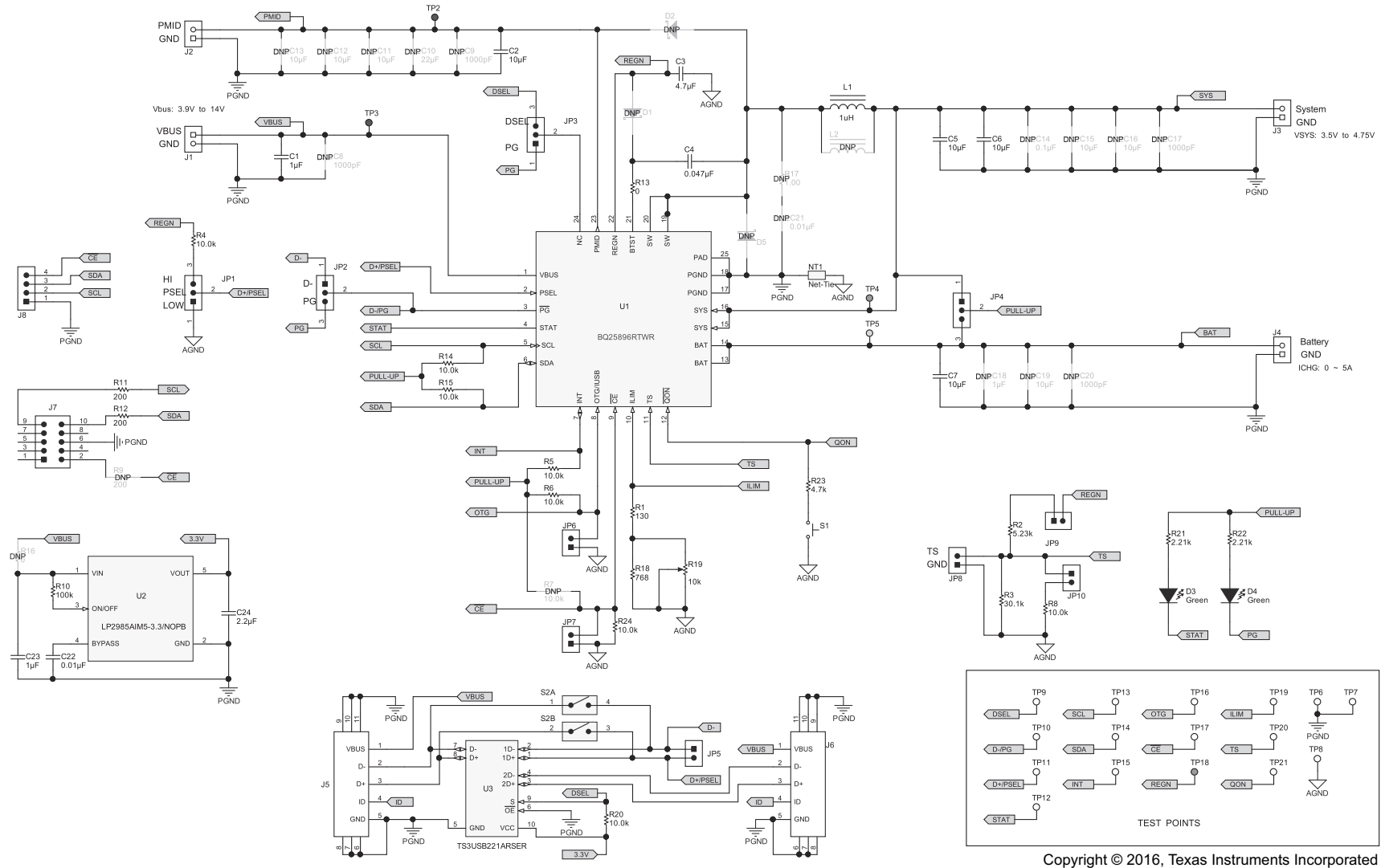

Figure 22. bq25896 EVM Schematic

Copyright © 2016, Texas Instruments Incorporated

4.3 Bill of Materials

Table 5 lists the bq25890EVM-664 BOM, Table 6 lists the bq25892EVM-664 BOM, Table 7 lists the bq25895EVM-664 BOM, Table 8 lists the bq25895MEVM-664 BOM and Table 9 lists the bq25896EVM-664 BOM.

Table 5. bq25890EVM-664 Bill of Materials

Designator	Qty.	Value	Description	Package Reference	Part Number	Manufacturer
C1	1	1µF	CAP, CERM, 1 µF, 25 V, ±10%, X7R, 0805	0805	GRM219R71E105KA88D	Murata
C2	1	10µF	CAP, CERM, 10µF, 25V, ±10%, X5R, 0805	0805	C2012X5R1E106K125AB	TDK
C3	1	4.7µF	CAP, CERM, 4.7µF, 16V, ±10%, X5R, 0603	0603	GRM188R61C475KAAJ	Murata
C4	1	0.047µF	CAP, CERM, 0.047µF, 25V, ±10%, X7R, 0402	0402	GRM155R71E473KA88D	Murata
C5, C6, C7	3	10µF	CAP, CERM, 10 µF, 10 V, ±10%, X7R, 0805	0805	GRM21BR71A106KE51L	Murata
C22	1	0.01µF	CAP, CERM, 0.01µF, 25V, ±10%, X7R, 0402	0402	C1005X7R1E103K	TDK
C23	1	1µF	CAP, CERM, 1µF, 25V, ±10%, X7R, 0603	0603	C1608X7R1E105K080AB	TDK
C24	1	2.2µF	CAP, CERM, 2.2µF, 10V, ±10%, X5R, 0402	0402	C1005X5R1A225K050BC	TDK
D3, D4	2	Green	LED, Green, SMD	1.6x0.8x0.8mm	LTST-C190GKT	Lite-On
H1, H2, H3, H4	4		Bumpon, Hemisphere, 0.44 x 0.20, Clear	Transparent Bumpon	SJ-5303 (CLEAR)	3M
J1, J2, J3, J4	4	2x1	Conn Term Block, 2POS, 3.81mm, TH	2POS Terminal Block	1727010	Phoenix Contact
J5, J6	2		Connector, Receptacle, Micro-USB Type B, R/A, Bottom Mount SMT	7.5x2.45x5mm	0473460001	Molex
J7	1		Header (shrouded), 100mil, 5x2, High-Temperature, Gold, TH	5x2 Shrouded header	N2510-6002-RB	3M
J8	1		Header, 100mil, 4x1, R/A, TH	4x1 R/A Header	22-05-3041	Molex
JP1–JP4	4		Header, 100mil, 3x1, Tin plated, TH	Header, 3 PIN, 100mil, Tin	PEC03SAAN	Sullins Connector Solutions
JP5–JP10	6		Header, 100mil, 2x1, Tin plated, TH	Header, 2 PIN, 100mil, Tin	PEC02SAAN	Sullins Connector Solutions
L1	1	1µH	Inductor, Shielded Drum Core, Powdered Iron, 1µH, 7A, 0.0181 Ω, SMD	5.49x2x5.18mm	IHLP2020BZER1R0M11	Vishay-Dale
LBL1	1		Thermal Transfer Printable Labels, 0.650" W x 0.200" H - 10,000 per roll	PCB Label 0.650"H x 0.200"W	THT-14-423-10	Brady
R1	1	130	RES, 130 Ω, 1%, 0.063W, 0402	0402	CRCW0402130RFKED	Vishay-Dale
R2	1	5.23k	RES, 5.23kΩ, 1%, 0.063W, 0402	0402	CRCW04025K23FKED	Vishay-Dale
R3	1	30.1k	RES, 30.1kΩ, 1%, 0.063W, 0402	0402	CRCW040230K1FKED	Vishay-Dale
R4–R6, R8, R14, R15, R20, R24	8	10.0k	RES, 10.0kΩ, 1%, 0.063W, 0402	0402	CRCW040210K0FKED	Vishay-Dale
R9, R11, R12	3	200	RES, 200 Ω, 1%, 0.063W, 0402	0402	CRCW0402200RFKED	Vishay-Dale
R10	1	100k	RES, 100kΩ, 1%, 0.063W, 0402	0402	CRCW0402100KFKED	Vishay-Dale
R13, R16	2	0	RES, 0 Ω, 5%, 0.063W, 0402	0402	CRCW04020000Z0ED	Vishay-Dale
R18	1	768	RES, 768 Ω, 1%, 0.063W, 0402	0402	CRCW0402768RFKED	Vishay-Dale
R19	1	10k	Trimmer, 10kΩ, 0.25W, TH	4.5x8x6.7mm	3266W-1-103LF	Bourns
R21, R22	2	2.21k	RES, 2.21kΩ, 1%, 0.063W, 0402	0402	CRCW04022K21FKED	Vishay-Dale
R23	1	4.7k	RES, 4.7kΩ, 5%, 0.063W, 0402	0402	CRCW04024K70JNED	Vishay-Dale
S1	1		Switch, Normally open, 2.3N force, 200k operations, SMD	KSR	KSR221GLFS	C and K Components
S2	1		DIP Switch, SPST, 2Pos, Slide, SMT	SW, 4.7x1.45x3mm	CVS-02TB	Copal Electronics
SH-JP2–SH-JP5, SH-JP9, SH-JP10	6	1x2	Shunt, 100mil, Gold plated, Black	Shunt	969102-0000-DA	3M

Table 5. bq25890EVM-664 Bill of Materials (continued)

Designator	Qty.	Value	Description	Package Reference	Part Number	Manufacturer
TP2, TP3	2	Red	Test Point, Miniature, Red, TH	Red Miniature Testpoint	5000	Keystone
TP4, TP18	2	Orange	Test Point, Miniature, Orange, TH	Orange Miniature Testpoint	5003	Keystone
TP5	1	Yellow	Test Point, Miniature, Yellow, TH	Yellow Miniature Testpoint	5004	Keystone
TP6, TP7, TP8	3	SMT	Test Point, Compact, SMT	Testpoint_Keystone_Compact	5016	Keystone
TP9-TP17, TP19-TP21	12	White	Test Point, Miniature, White, TH	White Miniature Testpoint	5002	Keystone
U1	1		I2C Controlled 5A Single Cell Charger with NVDC Power Path Management and MaxCharge™ High Voltage Adapter Support, RTW0024H	RTW0024H	BQ25890RTWR	Texas Instruments
U2	1		Micropower 150 mA Low-Noise Ultra Low-Dropout Regulator in SOT-23 Package, DBV0005A	DBV0005A	LP2985AIM5-3.3/NOPB	Texas Instruments
U3	1		ESD Protected, High-Speed USB 2.0 (480-Mbps) 1:2 Multiplexer / Demultiplexer Switch, 1:2 Mux / Demux, 6 Ω RON, 2.5 to 3.3V, -40 to 85°C, 10-Pin UQFN (RSE), Green (RoHS & no Sb/Br)	RSE0010A	TS3USB221ARSER	Texas Instruments
C8, C9, C17, C20	0	1000pF	CAP, CERM, 1000pF, 25V, ±5%, C0G/NP0, 0402	0402	C1005C0G1E102J	TDK
C10	0	22µF	CAP, CERM, 22 µF, 25 V, ±20%, X5R, 0805	0805	GRM21BR61E226ME44	Murata
C11, C12, C13	0	10µF	CAP, CERM, 10µF, 25V, ±20%, X5R, 0603	0603	GRM188R61E106MA73	Murata
C14	0	0.1µF	CAP, CERM, 0.1µF, 16V, ±10%, X7R, 0603	0603	C1608X7R1C104K	TDK
C15, C16, C19	0	10µF	CAP, CERM, 10 µF, 10 V, ±10%, X7R, 0805	0805	GRM21BR71A106KE51L	Murata
C18	0	1µF	CAP, CERM, 1µF, 16V, ±10%, X7R, 0603	0603	C1608X7R1C105K	TDK
C21	0	0.01µF	CAP, CERM, 0.01µF, 25V, ±10%, X7R, 0402	0402	C1005X7R1E103K	TDK
D1	0	40V	Diode, Schottky, 40V, 0.38A, SOD-523	SOD-523	ZLLS350TA	Diodes Inc.
D2	0	20V	Diode, Schottky, 20 V, 1 A, 1.4x0.6x0.31mm	1.4x0.6x0.31mm	NSR10F20NXT5G	ON Semiconductor
D5	0	30V	Diode, Schottky, 30 V, 1 A, SOD-123	SOD-123	B130LAW-7-F	Diodes Inc.
FID1, FID2, FID3	0		Fiducial mark. There is nothing to buy or mount.	Fiducial	N/A	N/A
L2	0	1.5µH	Inductor, Flat Wire, Powdered Iron, 1.5 µH, 3 A, 0.05 Ω, SMD	4.7x1.2x4.0mm	SRP4012-1R5M	Bourns
R7	0	10.0k	RES, 10.0kΩ, 1%, 0.063W, 0402	0402	CRCW040210K0FKED	Vishay-Dale
R17	0	1.00	RES, 1.00 Ω, 1%, 0.125W, 0805	0805	CRCW08051R00FKEA	Vishay-Dale
SH-JP1	0	1x2	Shunt, 100mil, Gold plated, Black	Shunt	969102-0000-DA	3M

Table 6. bq25892EVM-664 Bill of Materials

Designator	Qty.	Value	Description	Package Reference	PartNumber	Manufacturer
C1	1	1µF	CAP, CERM, 1 µF, 25 V, ±10%, X7R, 0805	0805	GRM219R71E105KA88D	MuRata
C2	1	10µF	CAP, CERM, 10µF, 25V, ±10%, X5R, 0805	0805	C2012X5R1E106K125AB	TDK
C3	1	4.7µF	CAP, CERM, 4.7µF, 16V, ±10%, X5R, 0603	0603	GRM188R61C475KAAJ	MuRata
C4	1	0.047µF	CAP, CERM, 0.047µF, 25V, ±10%, X7R, 0402	0402	GRM155R71E473KA88D	MuRata
C5, C6, C7	3	10µF	CAP, CERM, 10 µF, 10 V, ±10%, X7R, 0805	0805	GRM21BR71A106KE51L	MuRata
C22	1	0.01µF	CAP, CERM, 0.01µF, 25V, ±10%, X7R, 0402	0402	C1005X7R1E103K	TDK
C23	1	1µF	CAP, CERM, 1µF, 25V, ±10%, X7R, 0603	0603	C1608X7R1E105K080AB	TDK
C24	1	2.2µF	CAP, CERM, 2.2µF, 10V, ±10%, X5R, 0402	0402	C1005X5R1A225K050BC	TDK
D3, D4	2	Green	LED, Green, SMD	1.6x0.8x0.8mm	LTST-C190GKT	Lite-On
H1, H2, H3, H4	4		Bump, Hemisphere, 0.44 × 0.20, Clear	Transparent Bump	SJ-5303 (CLEAR)	3M
J1, J2, J3, J4	4	2x1	Conn Term Block, 2POS, 3.81mm, TH	2POS Terminal Block	1727010	Phoenix Contact
J5, J6	2		Connector, Receptacle, Micro-USB Type B, R/A, Bottom Mount SMT	7.5x2.45x5mm	0473460001	Molex
J7	1		Header (shrouded), 100mil, 5x2, High-Temperature, Gold, TH	5x2 Shrouded header	N2510-6002-RB	3M
J8	1		Header, 100mil, 4x1, R/A, TH	4x1 R/A Header	22-05-3041	Molex
JP1, JP2, JP3, JP4	4		Header, 100mil, 3x1, Tin plated, TH	Header, 3 PIN, 100mil, Tin	PEC03SAAN	Sullins Connector Solutions
JP5, JP6, JP7, JP8, JP9, JP10	6		Header, 100mil, 2x1, Tin plated, TH	Header, 2 PIN, 100mil, Tin	PEC02SAAN	Sullins Connector Solutions
L1	1	1µH	Inductor, Shielded Drum Core, Powdered Iron, 1µH, 7A, 0.0181 Ω, SMD	5.49x2x5.18mm	IHLP2020BZER1R0M11	Vishay-Dale
LBL1	1		Thermal Transfer Printable Labels, 0.650" W x 0.200" H - 10,000 per roll	PCB Label 0.650"H x 0.200"W	THT-14-423-10	Brady
R1	1	130	RES, 130 Ω, 1%, 0.063W, 0402	0402	CRCW0402130RFKED	Vishay-Dale
R2	1	5.23k	RES, 5.23kΩ, 1%, 0.063W, 0402	0402	CRCW04025K23FKED	Vishay-Dale
R3	1	30.1k	RES, 30.1kΩ, 1%, 0.063W, 0402	0402	CRCW040230K1FKED	Vishay-Dale
R4–R6, R8, R14, R15, R20, R24	8	10.0k	RES, 10.0kΩ, 1%, 0.063W, 0402	0402	CRCW040210K0FKED	Vishay-Dale
R9, R11, R12	3	200	RES, 200 Ω, 1%, 0.063W, 0402	0402	CRCW0402200RFKED	Vishay-Dale
R10	1	100k	RES, 100kΩ, 1%, 0.063W, 0402	0402	CRCW0402100KFKED	Vishay-Dale
R13	1	0	RES, 0 Ω, 5%, 0.063W, 0402	0402	CRCW04020000Z0ED	Vishay-Dale
R18	1	768	RES, 768 Ω, 1%, 0.063W, 0402	0402	CRCW0402768RFKED	Vishay-Dale
R19	1	10k	Trimmer, 10kΩ, 0.25W, TH	4.5x8x6.7mm	3266W-1-103LF	Bourns
R21, R22	2	2.21k	RES, 2.21kΩ, 1%, 0.063W, 0402	0402	CRCW04022K21FKED	Vishay-Dale
R23	1	4.7k	RES, 4.7kΩ, 5%, 0.063W, 0402	0402	CRCW04024K70JNED	Vishay-Dale
S1	1		Switch, Normally open, 2.3N force, 200k operations, SMD	KSR	KSR221GLFS	C and K Components
S2	1		DIP Switch, SPST, 2Pos, Slide, SMT	SW, 4.7x1.45x3mm	CVS-02TB	Copal Electronics
SH-JP1—SH-JP4, SH-JP9, SH-JP10	6	1x2	Shunt, 100mil, Gold plated, Black	Shunt	969102-0000-DA	3M
TP2, TP3	2	Red	Test Point, Miniature, Red, TH	Red Miniature Testpoint	5000	Keystone
TP4, TP18	2	Orange	Test Point, Miniature, Orange, TH	Orange Miniature Testpoint	5003	Keystone
TP5	1	Yellow	Test Point, Miniature, Yellow, TH	Yellow Miniature Testpoint	5004	Keystone
TP6, TP7, TP8	3	SMT	Test Point, Compact, SMT	Testpoint_Keystone_Compact	5016	Keystone

Table 6. bq25892EVM-664 Bill of Materials (continued)

Designator	Qty.	Value	Description	Package Reference	PartNumber	Manufacturer
TP9–TP17, TP19–TP21	12	White	Test Point, Miniature, White, TH	White Miniature Testpoint	5002	Keystone
U1	1		I2C Controlled 5A Single Cell Charger with NVDC Power Path Management and MaxCharge™ High Voltage Adapter Support, RTW0024H	RTW0024H	BQ25892RTWR	Texas Instruments
U2	1		Micropower 150 mA Low-Noise Ultra Low-Dropout Regulator in SOT-23 Package, DBV0005A	DBV0005A	LP2985AIM5-3.3/NOPB	Texas Instruments
U3	1		ESD Protected, High-Speed USB 2.0 (480-Mbps) 1:2 Multiplexer / Demultiplexer Switch, 1:2 Mux / Demux, 6 Ω RON, 2.5 to 3.3V, -40 to 85°C, 10-Pin UQFN (RSE), Green (RoHS & no Sb/Br)	RSE0010A	TS3USB221ARSER	Texas Instruments
C8, C9, C17, C20	0	1000pF	CAP, CERM, 1000pF, 25V, ±5%, C0G/NP0, 0402	0402	C1005C0G1E102J	TDK
C10	0	22µF	CAP, CERM, 22 µF, 25 V, ±20%, X5R, 0805	0805	GRM21BR61E226ME44	Murata
C11, C12, C13	0	10µF	CAP, CERM, 10µF, 25V, ±20%, X5R, 0603	0603	GRM188R61E106MA73	Murata
C14	0	0.1µF	CAP, CERM, 0.1µF, 16V, ±10%, X7R, 0603	0603	C1608X7R1C104K	TDK
C15, C16, C19	0	10µF	CAP, CERM, 10 µF, 10 V, ±10%, X7R, 0805	0805	GRM21BR71A106KE51L	Murata
C18	0	1µF	CAP, CERM, 1µF, 16V, ±10%, X7R, 0603	0603	C1608X7R1C105K	TDK
C21	0	0.01µF	CAP, CERM, 0.01µF, 25V, ±10%, X7R, 0402	0402	C1005X7R1E103K	TDK
D1	0	40V	Diode, Schottky, 40V, 0.38A, SOD-523	SOD-523	ZLLS350TA	Diodes Inc.
D2	0	20V	Diode, Schottky, 20 V, 1 A, 1.4x0.6x0.31mm	1.4x0.6x0.31mm	NSR10F20NXT5G	ON Semiconductor
D5	0	30V	Diode, Schottky, 30 V, 1 A, SOD-123	SOD-123	B130LAW-7-F	Diodes Inc.
FID1, FID2, FID3	0		Fiducial mark. There is nothing to buy or mount.	Fiducial	N/A	N/A
L2	0	1.5µH	Inductor, Flat Wire, Powdered Iron, 1.5 µH, 3 A, 0.05 Ω, SMD	4.7x1.2x4.0mm	SRP4012-1R5M	Bourns
R7	0	10.0k	RES, 10.0kΩ, 1%, 0.063W, 0402	0402	CRCW040210K0FKED	Vishay-Dale
R16	0	0	RES, 0 Ω 5%, 0.063W, 0402	0402	CRCW04020000Z0ED	Vishay-Dale
R17	0	1.00	RES, 1.00 Ω, 1%, 0.125W, 0805	0805	CRCW08051R00FKEA	Vishay-Dale
SH-JP5	0	1x2	Shunt, 100mil, Gold plated, Black	Shunt	969102-0000-DA	3M

Table 7. bq25895EVM-664 Bill of Materials

Designator	Qty.	Value	Description	PackageReference	Part Number	Manufacturer
C1	1	1µF	CAP, CERM, 1 µF, 25 V, ±10%, X7R, 0805	0805	GRM219R71E105KA88D	Murata
C2	1	10µF	CAP, CERM, 10µF, 25V, ±10%, X5R, 0805	0805	C2012X5R1E106K125AB	TDK
C3	1	4.7µF	CAP, CERM, 4.7µF, 16V, ±10%, X5R, 0603	0603	GRM188R61C475KAAJ	Murata
C4	1	0.047µF	CAP, CERM, 0.047µF, 25V, ±10%, X7R, 0402	0402	GRM155R71E473KA88D	Murata
C5, C6, C7	3	10µF	CAP, CERM, 10 µF, 10 V, ±10%, X7R, 0805	0805	GRM21BR71A106KE51L	Murata
C10	1	22µF	CAP, CERM, 22 µF, 25 V, ±20%, X5R, 0805	0805	GRM21BR61E226ME44	Murata
C11, C12, C13	3	10µF	CAP, CERM, 10µF, 25V, ±20%, X5R, 0603	0603	GRM188R61E106MA73	Murata
C22	1	0.01µF	CAP, CERM, 0.01µF, 25V, ±10%, X7R, 0402	0402	C1005X7R1E103K	TDK
C23	1	1µF	CAP, CERM, 1µF, 25V, ±10%, X7R, 0603	0603	C1608X7R1E105K080AB	TDK
C24	1	2.2µF	CAP, CERM, 2.2µF, 10V, ±10%, X5R, 0402	0402	C1005X5R1A225K050BC	TDK
D2	1	20V	Diode, Schottky, 20 V, 1 A, 1.4x0.6x0.31mm	1.4x0.6x0.31mm	NSR10F20NXT5G	ON Semiconductor
D3, D4	2	Green	LED, Green, SMD	1.6x0.8x0.8mm	LTST-C190GKT	Lite-On
H1, H2, H3, H4	4		Bump, Hemisphere, 0.44 x 0.20, Clear	Transparent Bump	SJ-5303 (CLEAR)	3M
J1, J2, J3, J4	4	2x1	Conn Term Block, 2POS, 3.81mm, TH	2POS Terminal Block	1727010	Phoenix Contact
J5, J6	2		Connector, Receptacle, Micro-USB Type B, R/A, Bottom Mount SMT	7.5x2.45x5mm	0473460001	Molex
J7	1		Header (shrouded), 100mil, 5x2, High-Temperature, Gold, TH	5x2 Shrouded header	N2510-6002-RB	3M
J8	1		Header, 100mil, 4x1, R/A, TH	4x1 R/A Header	22-05-3041	Molex
JP1, JP2, JP3, JP4	4		Header, 100mil, 3x1, Tin plated, TH	Header, 3 PIN, 100mil, Tin	PEC03SAAN	Sullins Connector Solutions
JP5-JP10	6		Header, 100mil, 2x1, Tin plated, TH	Header, 2 PIN, 100mil, Tin	PEC02SAAN	Sullins Connector Solutions
L1	1	2.2µH	Inductor, Shielded Drum Core, Powdered Iron, 2.2 µH, 8 A, 0.018 ohm, SMD	IHLP-2525CZ	IHLP2525CZER2R2M01	Vishay-Dale
LBL1	1		Thermal Transfer Printable Labels, 0.650" W x 0.200" H - 10,000 per roll	PCB Label 0.650"H x 0.200"W	THT-14-423-10	Brady
R1	1	130	RES, 130 Ω, 1%, 0.063W, 0402	0402	CRCW0402130RFKED	Vishay-Dale
R2	1	5.23k	RES, 5.23kΩ, 1%, 0.063W, 0402	0402	CRCW04025K23FKED	Vishay-Dale
R3	1	30.1k	RES, 30.1kΩ, 1%, 0.063W, 0402	0402	CRCW040230K1FKED	Vishay-Dale
R4-R6, R8, R14, R15, R20, R24	8	10.0k	RES, 10.0kΩ, 1%, 0.063W, 0402	0402	CRCW040210K0FKED	Vishay-Dale
R9, R11, R12	3	200	RES, 200 Ω, 1%, 0.063W, 0402	0402	CRCW0402200RFKED	Vishay-Dale
R10	1	100k	RES, 100k Ω, 1%, 0.063W, 0402	0402	CRCW0402100KFKED	Vishay-Dale
R13, R16	2	0	RES, 0 Ω, 5%, 0.063W, 0402	0402	CRCW04020000Z0ED	Vishay-Dale
R18	1	768	RES, 768 Ω, 1%, 0.063W, 0402	0402	CRCW0402768RFKED	Vishay-Dale
R19	1	10k	Trimmer, 10kΩ, 0.25W, TH	4.5x8x6.7mm	3266W-1-103LF	Bourns
R21, R22	2	2.21k	RES, 2.21k Ω, 1%, 0.063W, 0402	0402	CRCW04022K21FKED	Vishay-Dale
R23	1	4.7k	RES, 4.7kΩ 5%, 0.063W, 0402	0402	CRCW04024K70JNED	Vishay-Dale
S1	1		Switch, Normally open, 2.3N force, 200k operations, SMD	KSR	KSR221GLFS	C and K Components
S2	1		DIP Switch, SPST, 2Pos, Slide, SMT	SW, 4.7x1.45x3mm	CVS-02TB	Copal Electronics
SH-JP2, SH-JP3, SH-JP4, SH-JP5, SH-JP9, SH-JP10	6	1x2	Shunt, 100mil, Gold plated, Black	Shunt	969102-0000-DA	3M
TP2, TP3	2	Red	Test Point, Miniature, Red, TH	Red Miniature Testpoint	5000	Keystone
TP4, TP18	2	Orange	Test Point, Miniature, Orange, TH	Orange Miniature Testpoint	5003	Keystone

Table 7. bq25895EVM-664 Bill of Materials (continued)

Designator	Qty.	Value	Description	PackageReference	Part Number	Manufacturer
TP5	1	Yellow	Test Point, Miniature, Yellow, TH	Yellow Miniature Testpoint	5004	Keystone
TP6, TP7, TP8	3	SMT	Test Point, Compact, SMT	Testpoint_Keystone_Compact	5016	Keystone
TP9, TP10, TP11, TP12, TP13, TP14, TP15, TP16, TP17, TP19, TP20, TP21	12	White	Test Point, Miniature, White, TH	White Miniature Testpoint	5002	Keystone
U1	1		I2C Controlled 5A Single Cell Charger with NVDC Power Path Management and MaxCharge™ High Voltage Adapter Support, RTW0024H	RTW0024H	BQ25895RTWR	Texas Instruments
U2	1		Micropower 150 mA Low-Noise Ultra Low-Dropout Regulator in SOT-23 Package, DBV0005A	DBV0005A	LP2985AIM5-3.3/NOPB	Texas Instruments
U3	1		ESD Protected, High-Speed USB 2.0 (480-Mbps) 1:2 Multiplexer / Demultiplexer Switch, 1:2 Mux / Demux, 6 Ω RON, 2.5 to 3.3V, -40 to 85°C, 10-Pin UQFN (RSE), Green (RoHS & no Sb/Br)	RSE0010A	TS3USB221ARSER	Texas Instruments
C8, C9, C17, C20	0	1000pF	CAP, CERM, 1000pF, 25V, ±5%, C0G/NP0, 0402	0402	C1005C0G1E102J	TDK
C14	0	0.1µF	CAP, CERM, 0.1uF, 16V, ±10%, X7R, 0603	0603	C1608X7R1C104K	TDK
C15, C16, C19	0	10µF	CAP, CERM, 10 µF, 10 V, ±10%, X7R, 0805	0805	GRM21BR71A106KE51L	Murata
C18	0	1µF	CAP, CERM, 1uF, 16V, ±10%, X7R, 0603	0603	C1608X7R1C105K	TDK
C21	0	0.01µF	CAP, CERM, 0.01uF, 25V, ±10%, X7R, 0402	0402	C1005X7R1E103K	TDK
D1	0	40V	Diode, Schottky, 40V, 0.38A, SOD-523	SOD-523	ZLLS350TA	Diodes Inc.
D5	0	30V	Diode, Schottky, 30 V, 1 A, SOD-123	SOD-123	B130LAW-7-F	Diodes Inc.
FID1, FID2, FID3	0		Fiducial mark. There is nothing to buy or mount.	Fiducial	N/A	N/A
L2	0	1.5µH	Inductor, Flat Wire, Powdered Iron, 1.5 µH, 3 A, 0.05 Ω, SMD	4.7x1.2x4.0mm	SRP4012-1R5M	Bourns
R7	0	10.0k	RES, 10.0kΩ, 1%, 0.063W, 0402	0402	CRCW040210K0FKED	Vishay-Dale
R17	0	1.00	RES, 1.00 Ω, 1%, 0.125W, 0805	0805	CRCW08051R00FKEA	Vishay-Dale
SH-JP1	0	1x2	Shunt, 100mil, Gold plated, Black	Shunt	969102-0000-DA	3M

Table 8. bq25895MEVM-664 Bill of Materials

Designator	Qty.	Value	Description	PackageReference	Part Number	Manufacturer
C1	1	1µF	CAP, CERM, 1 µF, 25 V, ±10%, X7R, 0805	0805	GRM219R71E105KA88D	Murata
C2	1	10µF	CAP, CERM, 10µF, 25V, ±10%, X5R, 0805	0805	C2012X5R1E106K125AB	TDK
C3	1	4.7µF	CAP, CERM, 4.7µF, 16V, ±10%, X5R, 0603	0603	GRM188R61C475KAAJ	Murata
C4	1	0.047µF	CAP, CERM, 0.047µF, 25V, ±10%, X7R, 0402	0402	GRM155R71E473KA88D	Murata
C5, C6, C7	3	10µF	CAP, CERM, 10 µF, 10 V, ±10%, X7R, 0805	0805	GRM21BR71A106KE51L	Murata
C10	1	22µF	CAP, CERM, 22 µF, 25 V, ±20%, X5R, 0805	0805	GRM21BR61E226ME44	Murata
C11, C12, C13	3	10µF	CAP, CERM, 10µF, 25V, ±20%, X5R, 0603	0603	GRM188R61E106MA73	Murata
C22	1	0.01µF	CAP, CERM, 0.01µF, 25V, ±10%, X7R, 0402	0402	C1005X7R1E103K	TDK
C23	1	1µF	CAP, CERM, 1µF, 25V, ±10%, X7R, 0603	0603	C1608X7R1E105K080AB	TDK
C24	1	2.2µF	CAP, CERM, 2.2µF, 10V, ±10%, X5R, 0402	0402	C1005X5R1A225K050BC	TDK
D2	1	20V	Diode, Schottky, 20 V, 1 A, 1.4x0.6x0.31mm	1.4x0.6x0.31mm	NSR10F20NXT5G	ON Semiconductor
D3, D4	2	Green	LED, Green, SMD	1.6x0.8x0.8mm	LTST-C190GKT	Lite-On
H1, H2, H3, H4	4		Bump, Hemisphere, 0.44 x 0.20, Clear	Transparent Bump	SJ-5303 (CLEAR)	3M
J1, J2, J3, J4	4	2x1	Conn Term Block, 2POS, 3.81mm, TH	2POS Terminal Block	1727010	Phoenix Contact
J5, J6	2		Connector, Receptacle, Micro-USB Type B, R/A, Bottom Mount SMT	7.5x2.45x5mm	0473460001	Molex
J7	1		Header (shrouded), 100mil, 5x2, High-Temperature, Gold, TH	5x2 Shrouded header	N2510-6002-RB	3M
J8	1		Header, 100mil, 4x1, R/A, TH	4x1 R/A Header	22-05-3041	Molex
JP1, JP2, JP3, JP4	4		Header, 100mil, 3x1, Tin plated, TH	Header, 3 PIN, 100mil, Tin	PEC03SAAN	Sullins Connector Solutions
JP5-JP10	6		Header, 100mil, 2x1, Tin plated, TH	Header, 2 PIN, 100mil, Tin	PEC02SAAN	Sullins Connector Solutions
L1	1	2.2µH	Inductor, Shielded Drum Core, Powdered Iron, 2.2 µH, 8 A, 0.018 ohm, SMD	IHLP-2525CZ	IHLP2525CZER2R2M01	Vishay-Dale
LBL1	1		Thermal Transfer Printable Labels, 0.650" W x 0.200" H - 10,000 per roll	PCB Label 0.650"H x 0.200"W	THT-14-423-10	Brady
R1	1	130	RES, 130 Ω, 1%, 0.063W, 0402	0402	CRCW0402130RFKED	Vishay-Dale
R2	1	5.23k	RES, 5.23kΩ, 1%, 0.063W, 0402	0402	CRCW04025K23FKED	Vishay-Dale
R3	1	30.1k	RES, 30.1kΩ, 1%, 0.063W, 0402	0402	CRCW040230K1FKED	Vishay-Dale
R4-R6, R8, R14, R15, R20, R24	8	10.0k	RES, 10.0kΩ, 1%, 0.063W, 0402	0402	CRCW040210K0FKED	Vishay-Dale
R9, R11, R12	3	200	RES, 200 Ω, 1%, 0.063W, 0402	0402	CRCW0402200RFKED	Vishay-Dale
R10	1	100k	RES, 100k Ω, 1%, 0.063W, 0402	0402	CRCW0402100KFKED	Vishay-Dale
R13, R16	2	0	RES, 0 Ω, 5%, 0.063W, 0402	0402	CRCW04020000Z0ED	Vishay-Dale
R18	1	768	RES, 768 Ω, 1%, 0.063W, 0402	0402	CRCW0402768RFKED	Vishay-Dale
R19	1	10k	Trimmer, 10kΩ, 0.25W, TH	4.5x8x6.7mm	3266W-1-103LF	Bourns
R21, R22	2	2.21k	RES, 2.21k Ω, 1%, 0.063W, 0402	0402	CRCW04022K21FKED	Vishay-Dale
R23	1	4.7k	RES, 4.7kΩ 5%, 0.063W, 0402	0402	CRCW04024K70JNED	Vishay-Dale
S1	1		Switch, Normally open, 2.3N force, 200k operations, SMD	KSR	KSR221GLFS	C and K Components
S2	1		DIP Switch, SPST, 2Pos, Slide, SMT	SW, 4.7x1.45x3mm	CVS-02TB	Copal Electronics
SH-JP2, SH-JP3, SH-JP4, SH-JP5, SH-JP9, SH-JP10	6	1x2	Shunt, 100mil, Gold plated, Black	Shunt	969102-0000-DA	3M
TP2, TP3	2	Red	Test Point, Miniature, Red, TH	Red Miniature Testpoint	5000	Keystone
TP4, TP18	2	Orange	Test Point, Miniature, Orange, TH	Orange Miniature Testpoint	5003	Keystone

Table 8. bq25895MEVM-664 Bill of Materials (continued)

Designator	Qty.	Value	Description	PackageReference	Part Number	Manufacturer
TP5	1	Yellow	Test Point, Miniature, Yellow, TH	Yellow Miniature Testpoint	5004	Keystone
TP6, TP7, TP8	3	SMT	Test Point, Compact, SMT	Testpoint_Keystone_Compact	5016	Keystone
TP9, TP10, TP11, TP12, TP13, TP14, TP15, TP16, TP17, TP19, TP20, TP21	12	White	Test Point, Miniature, White, TH	White Miniature Testpoint	5002	Keystone
U1	1		I2C Controlled 5A Single Cell Charger with NVDC Power Path Management and MaxCharge™ High Voltage Adapter Support, RTW0024H	RTW0024H	BQ25895MRTWR	Texas Instruments
U2	1		Micropower 150 mA Low-Noise Ultra Low-Dropout Regulator in SOT-23 Package, DBV0005A	DBV0005A	LP2985AIM5-3.3/NOPB	Texas Instruments
U3	1		ESD Protected, High-Speed USB 2.0 (480-Mbps) 1:2 Multiplexer / Demultiplexer Switch, 1:2 Mux / Demux, 6 Ω RON, 2.5 to 3.3V, -40 to 85°C, 10-Pin UQFN (RSE), Green (RoHS & no Sb/Br)	RSE0010A	TS3USB221ARSER	Texas Instruments
C8, C9, C17, C20	0	1000pF	CAP, CERM, 1000pF, 25V, ±5%, C0G/NP0, 0402	0402	C1005C0G1E102J	TDK
C14	0	0.1µF	CAP, CERM, 0.1uF, 16V, ±10%, X7R, 0603	0603	C1608X7R1C104K	TDK
C15, C16, C19	0	10µF	CAP, CERM, 10 µF, 10 V, ±10%, X7R, 0805	0805	GRM21BR71A106KE51L	Murata
C18	0	1µF	CAP, CERM, 1uF, 16V, ±10%, X7R, 0603	0603	C1608X7R1C105K	TDK
C21	0	0.01µF	CAP, CERM, 0.01uF, 25V, ±10%, X7R, 0402	0402	C1005X7R1E103K	TDK
D1	0	40V	Diode, Schottky, 40V, 0.38A, SOD-523	SOD-523	ZLLS350TA	Diodes Inc.
D5	0	30V	Diode, Schottky, 30 V, 1 A, SOD-123	SOD-123	B130LAW-7-F	Diodes Inc.
FID1, FID2, FID3	0		Fiducial mark. There is nothing to buy or mount.	Fiducial	N/A	N/A
L2	0	1.5µH	Inductor, Flat Wire, Powdered Iron, 1.5 µH, 3 A, 0.05 Ω, SMD	4.7x1.2x4.0mm	SRP4012-1R5M	Bourns
R7	0	10.0k	RES, 10.0kΩ, 1%, 0.063W, 0402	0402	CRCW040210K0FKED	Vishay-Dale
R17	0	1.00	RES, 1.00 Ω, 1%, 0.125W, 0805	0805	CRCW08051R00FKEA	Vishay-Dale
SH-JP1	0	1x2	Shunt, 100mil, Gold plated, Black	Shunt	969102-0000-DA	3M

Table 9. bq25896EVM-664 Bill of Materials

Designator	Qty.	Value	Description	PackageReference	Part Number	Manufacturer
C1	1	1uF	CAP, CERM, 1 µF, 25 V, +/- 10%, X7R, 0805	0805	GRM219R71E105KA88D	MuRata
C2	1	10uF	CAP, CERM, 10uF, 25V, +/-10%, X5R, 0805	0805	C2012X5R1E106K125AB	TDK
C3	1	4.7uF	CAP, CERM, 4.7uF, 16V, +/-10%, X5R, 0603	0603	GRM188R61C475KAAJ	MuRata
C4	1	0.047uF	CAP, CERM, 0.047uF, 25V, +/-10%, X7R, 0402	0402	GRM155R71E473KA88D	MuRata
C5, C6, C7	3	10uF	CAP, CERM, 10 µF, 10 V, +/- 10%, X7R, 0805	0805	GRM21BR71A106KE51L	MuRata
C22	1	0.01uF	CAP, CERM, 0.01uF, 25V, +/-10%, X7R, 0402	0402	C1005X7R1E103K	TDK
C23	1	1uF	CAP, CERM, 1uF, 25V, +/-10%, X7R, 0603	0603	C1608X7R1E105K080AB	TDK
C24	1	2.2uF	CAP, CERM, 2.2uF, 10V, +/-10%, X5R, 0402	0402	C1005X5R1A225K050BC	TDK
D3, D4	2	Green	LED, Green, SMD	1.6x0.8x0.8mm	LTST-C190GKT	Lite-On
H1, H2, H3, H4	4		Bumpon, Hemisphere, 0.44 X 0.20, Clear	Transparent Bumpon	SJ-5303 (CLEAR)	3M
J1, J2, J3, J4	4	2x1	Conn Term Block, 2POS, 3.81mm, TH	2POS Terminal Block	1727010	Phoenix Contact
J5, J6	2		Connector, Receptacle, Micro-USB Type B, R/A, Bottom Mount SMT	7.5x2.45x5mm	0473460001	Molex
J7	1		Header (shrouded), 100mil, 5x2, High-Temperature, Gold, TH	5x2 Shrouded header	N2510-6002-RB	3M
J8	1		Header, 100mil, 4x1, R/A, TH	4x1 R/A Header	22-05-3041	Molex
JP1, JP2, JP3, JP4	4		Header, 100mil, 3x1, Tin plated, TH	Header, 3 PIN, 100mil, Tin	PEC03SAAN	Sullins Connector Solutions
JP5, JP6, JP7, JP8, JP9, JP10	6		Header, 100mil, 2x1, Tin plated, TH	Header, 2 PIN, 100mil, Tin	PEC02SAAN	Sullins Connector Solutions
L1	1	1uH	Inductor, Shielded Drum Core, Powdered Iron, 1uH, 7A, 0.0181 ohm, SMD	5.49x2x5.18mm	IHLP2020BZER1R0M11	Vishay-Dale
LBL1	1		Thermal Transfer Printable Labels, 0.650" W x 0.200" H - 10,000 per roll	PCB Label 0.650"H x 0.200"W	THT-14-423-10	Brady
R1	1	130	RES, 130 ohm, 1%, 0.063W, 0402	0402	CRCW0402130RFKED	Vishay-Dale
R2	1	5.23k	RES, 5.23k ohm, 1%, 0.063W, 0402	0402	CRCW04025K23FKED	Vishay-Dale
R3	1	30.1k	RES, 30.1k ohm, 1%, 0.063W, 0402	0402	CRCW040230K1FKED	Vishay-Dale
R4, R5, R6, R8, R14, R15, R20, R24	8	10.0k	RES, 10.0k ohm, 1%, 0.063W, 0402	0402	CRCW040210K0FKED	Vishay-Dale
R10	1	100k	RES, 100k ohm, 1%, 0.063W, 0402	0402	CRCW0402100KFKE	Vishay-Dale
R11, R12	2	200	RES, 200 ohm, 1%, 0.063W, 0402	0402	CRCW0402200RFKED	Vishay-Dale
R13	1	0	RES, 0 ohm, 5%, 0.063W, 0402	0402	CRCW04020000Z0ED	Vishay-Dale
R18	1	768	RES, 768 ohm, 1%, 0.063W, 0402	0402	CRCW0402768RFKED	Vishay-Dale
R19	1	10k	Trimmer, 10k ohm, 0.25W, TH	4.5x8x6.7mm	3266W-1-103LF	Bourns
R21, R22	2	2.21k	RES, 2.21k ohm, 1%, 0.063W, 0402	0402	CRCW04022K21FKED	Vishay-Dale
R23	1	4.7k	RES, 4.7k ohm, 5%, 0.063W, 0402	0402	CRCW04024K70JNED	Vishay-Dale
S1	1		Switch, Normally open, 2.3N force, 200k operations, SMD	KSR	KSR221GLFS	C and K Components
S2	1		DIP Switch, SPST, 2Pos, Slide, SMT	SW, 4.7x1.45x3mm	CVS-02TB	Copal Electronics
SH-JP1, SH-JP2, SH-JP3, SH-JP4, SH-JP9, SH-JP10	6	1x2	Shunt, 100mil, Gold plated, Black	Shunt	969102-0000-DA	3M
TP2, TP3	2	Red	Test Point, Miniature, Red, TH	Red Miniature Testpoint	5000	Keystone
TP4, TP18	2	Orange	Test Point, Miniature, Orange, TH	Orange Miniature Testpoint	5003	Keystone
TP5	1	Yellow	Test Point, Miniature, Yellow, TH	Yellow Miniature Testpoint	5004	Keystone
TP6, TP7, TP8	3	SMT	Test Point, Compact, SMT	Testpoint_Keystone_Compact	5016	Keystone

Table 9. bq25896EVM-664 Bill of Materials (continued)

Designator	Qty.	Value	Description	PackageReference	Part Number	Manufacturer
TP9, TP10, TP11, TP12, TP13, TP14, TP15, TP16, TP17, TP19, TP20, TP21	12	White	Test Point, Miniature, White, TH	White Miniature Testpoint	5002	Keystone
U1	1		I2C Controlled 3A Single Cell Charger with NVDC Power Path Management and MaxCharge High Voltage Adapter Support, RTW0024H	RTW0024H	BQ25896RTWR	Texas Instruments
U2	1		Micropower 150 mA Low-Noise Ultra Low-Dropout Regulator in SOT-23 Package, DBV0005A	DBV0005A	LP2985AIM5-3.3/NOPB	Texas Instruments
U3	1		ESD Protected, High-Speed USB 2.0 (480-Mbps) 1:2 Multiplexer / Demultiplexer Switch, 1:2 Mux / Demux, 6 ohm RON, 2.5 to 3.3V, -40 to 85 degC, 10-Pin UQFN (RSE), Green (RoHS & no Sb/Br)	RSE0010A	TS3USB221ARSER	Texas Instruments
C8, C9, C17, C20	0	1000pF	CAP, CERM, 1000pF, 25V, +/-5%, C0G/NP0, 0402	0402	C1005C0G1E102J	TDK
C10	0	22uF	CAP, CERM, 22 uF, 25 V, +/- 20%, X5R, 0805	0805	GRM21BR61E226ME44	MuRata
C11, C12, C13	0	10uF	CAP, CERM, 10uF, 25V, +/-20%, X5R, 0603	0603	GRM188R61E106MA73	MuRata
C14	0	0.1uF	CAP, CERM, 0.1uF, 16V, +/-10%, X7R, 0603	0603	C1608X7R1C104K	TDK
C15, C16, C19	0	10uF	CAP, CERM, 10 uF, 10 V, +/- 10%, X7R, 0805	0805	GRM21BR71A106KE51L	MuRata
C18	0	1uF	CAP, CERM, 1uF, 16V, +/-10%, X7R, 0603	0603	C1608X7R1C105K	TDK
C21	0	0.01uF	CAP, CERM, 0.01uF, 25V, +/-10%, X7R, 0402	0402	C1005X7R1E103K	TDK
D1	0	40V	Diode, Schottky, 40V, 0.38A, SOD-523	SOD-523	ZLLS350TA	Diodes Inc.
D2	0	20V	Diode, Schottky, 20 V, 1 A, 1.4x0.6x0.31mm	1.4x0.6x0.31mm	NSR10F20NXT5G	ON Semiconductor
D5	0	30V	Diode, Schottky, 30 V, 1 A, SOD-123	SOD-123	B130LAW-7-F	Diodes Inc.
FID1, FID2, FID3	0		Fiducial mark. There is nothing to buy or mount.	Fiducial	N/A	N/A
L2	0	2.2uH	Inductor, Shielded Drum Core, Powdered Iron, 2.2 uH, 8 A, 0.018 ohm, SMD	IHLP-2525CZ	IHLP2525CZER2R2M01	Vishay-Dale
R7	0	10.0k	RES, 10.0k ohm, 1%, 0.063W, 0402	0402	CRCW040210K0FKED	Vishay-Dale
R9	0	200	RES, 200 ohm, 1%, 0.063W, 0402	0402	CRCW0402200RFKED	Vishay-Dale
R16	0	0	RES, 0 ohm, 5%, 0.063W, 0402	0402	CRCW04020000Z0ED	Vishay-Dale
R17	0	1.00	RES, 1.00 ohm, 1%, 0.125W, 0805	0805	CRCW08051R00FKEA	Vishay-Dale
SH-JP5	0	1x2	Shunt, 100mil, Gold plated, Black	Shunt	969102-0000-DA	3M

Revision History

NOTE: Page numbers for previous revisions may differ from page numbers in the current version.

Changes from A Revision (July 2015) to B Revision	Page
• Added <i>bq25896 EVM Schematic</i> Figure 22	20
• Added <i>bq25896 EVM BOM</i> Table 9	29

Revision History

Changes from Original (March 2015) to A Revision	Page
• Added <i>bq25895M EVM</i> to document.	1
• Changed version number on <i>BatteryManagementStudio-1.3.35</i>	4
• Changed <i>Install EV2300 Software</i> section.	4
• Changed <i>Connections of the EV2300 image</i>	5
• Deleted EV2400 reference in <i>Original Test Setup for PWR664 (bq2589x EVM) image</i>	5
• Changed steps 8 and 9 in the <i>Equipment Setup</i> section.	6
• Changed image in the <i>Communication Verification</i> section, step 3.	9
• Added <i>Clean-Up</i> section.	10
• Added <i>bq25895M EVM Schematic</i> image.	19
• Added <i>bq25895M EVM BOM</i> Table 8	27

IMPORTANT NOTICE AND DISCLAIMER

TI PROVIDES TECHNICAL AND RELIABILITY DATA (INCLUDING DATA SHEETS), DESIGN RESOURCES (INCLUDING REFERENCE DESIGNS), APPLICATION OR OTHER DESIGN ADVICE, WEB TOOLS, SAFETY INFORMATION, AND OTHER RESOURCES "AS IS" AND WITH ALL FAULTS, AND DISCLAIMS ALL WARRANTIES, EXPRESS AND IMPLIED, INCLUDING WITHOUT LIMITATION ANY IMPLIED WARRANTIES OF MERCHANTABILITY, FITNESS FOR A PARTICULAR PURPOSE OR NON-INFRINGEMENT OF THIRD PARTY INTELLECTUAL PROPERTY RIGHTS.

These resources are intended for skilled developers designing with TI products. You are solely responsible for (1) selecting the appropriate TI products for your application, (2) designing, validating and testing your application, and (3) ensuring your application meets applicable standards, and any other safety, security, regulatory or other requirements.

These resources are subject to change without notice. TI grants you permission to use these resources only for development of an application that uses the TI products described in the resource. Other reproduction and display of these resources is prohibited. No license is granted to any other TI intellectual property right or to any third party intellectual property right. TI disclaims responsibility for, and you will fully indemnify TI and its representatives against, any claims, damages, costs, losses, and liabilities arising out of your use of these resources.

TI's products are provided subject to [TI's Terms of Sale](#) or other applicable terms available either on ti.com or provided in conjunction with such TI products. TI's provision of these resources does not expand or otherwise alter TI's applicable warranties or warranty disclaimers for TI products.

TI objects to and rejects any additional or different terms you may have proposed.

Mailing Address: Texas Instruments, Post Office Box 655303, Dallas, Texas 75265
Copyright © 2022, Texas Instruments Incorporated

Looking for pricing, stock, or lifecycle information?

Click below to explore more details on WIN SOURCE:

 [View BQ25892EVM-664](#) on WIN SOURCE

 [Texas Instruments](#) Information

Optimize Your Supply Chain with WIN SOURCE Solutions

-  Global Sourcing Solution
-  Obsolete Management
-  Cost Control Management
-  Shortage Management
-  Alternative Solution
-  Excess Inventory Management