



**THE DATASHEET OF
BQ4832YMA-85**





bq4832Y

RTC Module With 32Kx8 NVSRAM

Features

- Integrated SRAM, real-time clock, CPU supervisor, crystal, power-fail circuit, and battery
- Real-Time Clock counts hundredths of seconds through years in BCD format
- RAM-like clock access
- Compatible with industry-standard 32K x 8 SRAMs
- Unlimited write cycles
- 10-year minimum data retention and clock operation in the absence of power
- Automatic power-fail chip deselect and write-protection
- Watchdog timer, power-on reset, alarm/periodic interrupt, power-fail and battery-low warning
- Software clock calibration for greater than ± 1 minute per month accuracy

General Description

The bq4832Y RTC Module is a non-volatile 262,144-bit SRAM organized as 32,768 words by 8 bits with an integral real-time clock and CPU supervisor. The CPU supervisor provides a programmable watchdog timer and a microprocessor reset. Other features include alarm, power-fail, and periodic interrupts, and a battery-low warning.

The device combines an internal lithium battery, quartz crystal, clock and power-fail chip, and a full CMOS SRAM in a plastic 32-pin DIP module. The RTC Module directly replaces industry-standard SRAMs and also fits into many EPROM and EEPROM sockets without any requirement for special write timing or limitations on the number of write cycles.

Registers for the real-time clock, alarm and other special functions are located in registers 7FF0h–7FFFh of the memory array.

The clock and alarm registers are dual-port read/write SRAM locations that are updated once per second by a clock control circuit from the internal clock counters. The dual-port registers allow clock updates to occur without interrupting normal access to the rest of the SRAM array.

The bq4832Y also contains a power-fail-detect circuit. The circuit deselects the device whenever V_{CC} falls below tolerance, providing a high degree of data security. The battery is electrically isolated when shipped from the factory to provide maximum battery capacity. The battery remains disconnected until the first application of V_{CC} .

Pin Connections

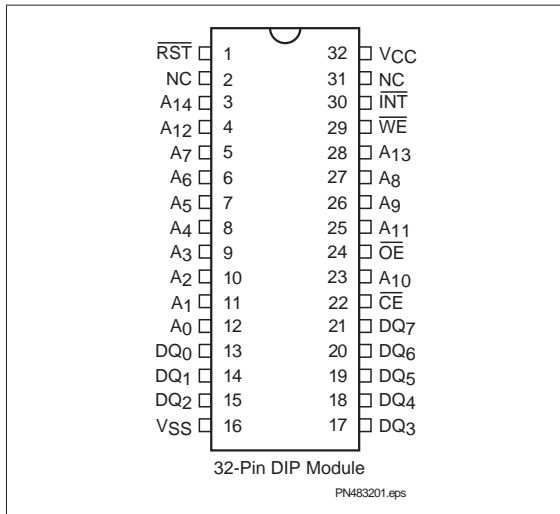

Pin Names

- A_0 – A_{14} Address input
- \overline{CE} Chip enable
- \overline{RST} Microprocessor reset
- \overline{WE} Write enable
- \overline{OE} Output enable
- DQ_0 – DQ_7 Data in/data out
- \overline{INT} Programmable interrupt
- V_{CC} +5 volts
- V_{SS} Ground

bq4832Y

Functional Description

Figure 1 is a block diagram of the bq4832Y. The following sections describe the bq4832Y functional operation,

including memory and clock interface, data-retention modes, power-on reset timing, watchdog timer activation, and interrupt generation.

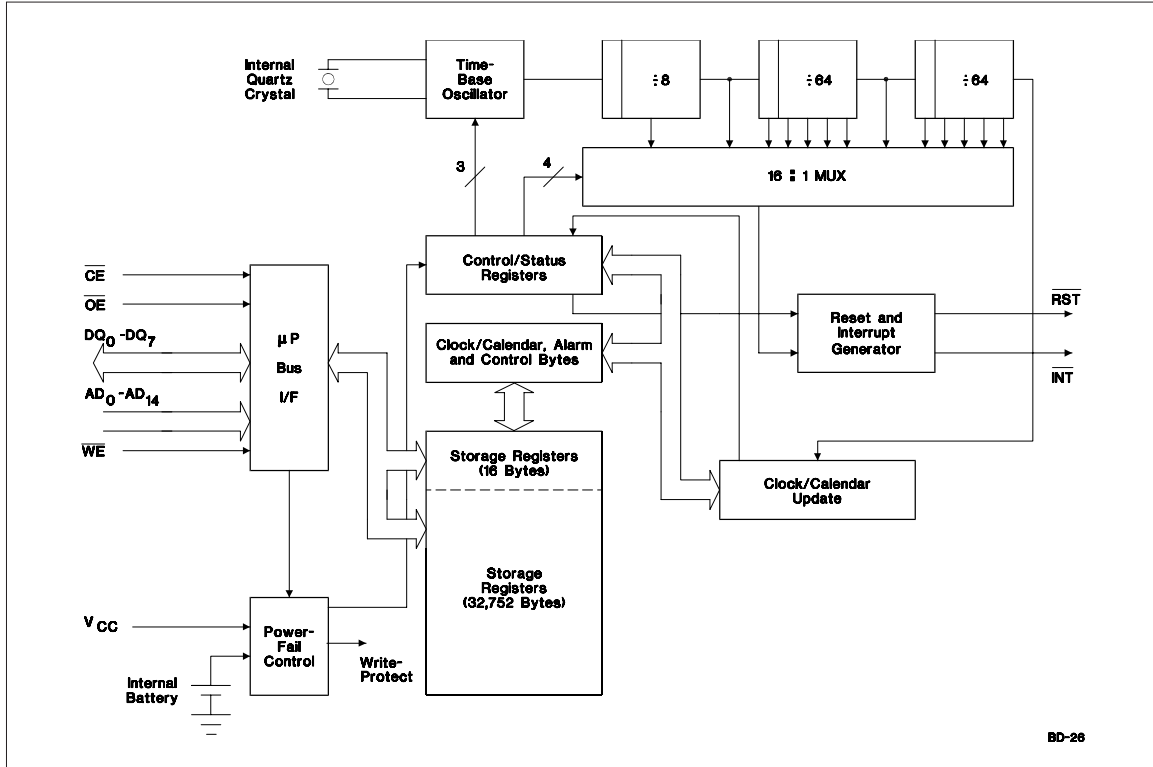

Figure 1. Block Diagram

Truth Table

V _{CC}	$\overline{\text{CE}}$	$\overline{\text{OE}}$	$\overline{\text{WE}}$	Mode	DQ	Power
< V _{CC} (max.)	V _{IH}	X	X	Deselect	High Z	Standby
	V _{IL}	X	V _{IL}	Write	D _{IN}	Active
> V _{CC} (min.)	V _{IL}	V _{IL}	V _{IH}	Read	D _{OUT}	Active
	V _{IL}	V _{IH}	V _{IH}	Read	High Z	Active
< V _{PFD} (min.) > V _{SO}	X	X	X	Deselect	High Z	CMOS standby
≤ V _{SO}	X	X	X	Deselect	High Z	Battery-backup mode

bq4832Y

Address Map

The bq4832Y provides 16 bytes of clock and control status registers and 32,752 bytes of storage RAM.

Figure 2 illustrates the address map for the bq4832Y. Table 1 is a map of the bq4832Y registers, and Table 2 describes the register bits.

Memory Interface

Read Mode

The bq4832Y is in read mode whenever \overline{OE} (output enable) is low and \overline{CE} (chip enable) is low. The device architecture allows ripple-through access of data from eight of 262,144 locations in the static storage array. Thus, the unique address specified by the 15 address inputs defines which one of the 32,768 bytes of data is to be accessed. Valid data is available at the data I/O pins within t_{AA} (address access time) after the last address input signal is stable, providing that the \overline{CE} and \overline{OE} (output enable) access times are also satisfied. If the \overline{CE} and \overline{OE} access times are not met, valid data is available after the latter of chip enable access time (t_{ACE}) or output enable access time (t_{OE}).

\overline{CE} and \overline{OE} control the state of the eight three-state data I/O signals. If the outputs are activated before t_{AA} , the data lines are driven to an indeterminate state until t_{AA} . If the address inputs are changed while \overline{CE} and \overline{OE} remain low, output data remains valid for t_{OH} (output data hold time), but goes indeterminate until the next address access.

Write Mode

The bq4832Y is in write mode whenever \overline{WE} and \overline{CE} are active. The start of a write is referenced from the latter-occurring falling edge of \overline{WE} or \overline{CE} . A write is terminated by the earlier rising edge of \overline{WE} or \overline{CE} . The addresses must be held valid throughout the cycle. \overline{CE} or \overline{WE} must return high for a minimum of t_{WR2} from \overline{CE} or t_{WR1} from \overline{WE} prior to the initiation of another read or write cycle.

Data-in must be valid t_{DW} prior to the end of write and remain valid for t_{DH1} or t_{DH2} afterward. \overline{OE} should be kept high during write cycles to avoid bus contention; although, if the output bus has been activated by a low on \overline{CE} and \overline{OE} , a low on \overline{WE} disables the outputs t_{WZ} after \overline{WE} falls.

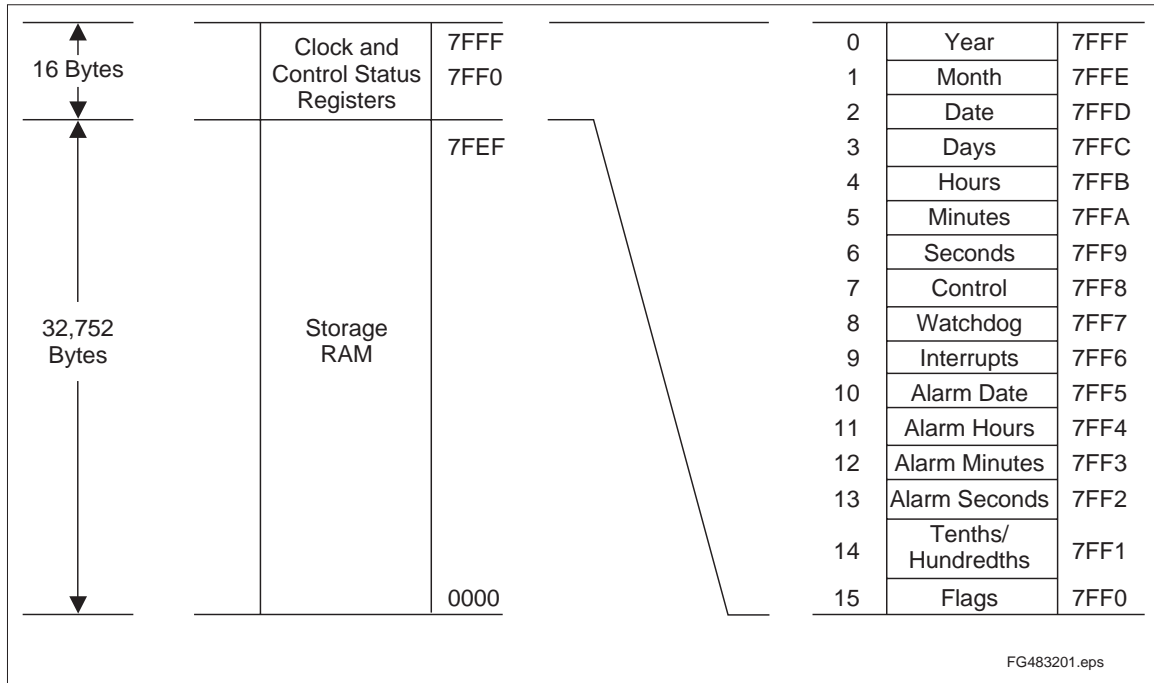

Figure 2. Address Map

bq4832Y

Data-Retention Mode

With valid V_{CC} applied, the bq4832Y operates as a conventional static RAM. Should the supply voltage decay, the RAM automatically power-fail deselects, write-protecting itself t_{WPT} after V_{CC} falls below V_{PFD} . All outputs become high impedance, and all inputs are treated as “don’t care.”

If power-fail detection occurs during a valid access, the memory cycle continues to completion. If the memory cycle fails to terminate within time t_{WPT} , write-protection takes place. When V_{CC} drops below V_{SO} , the control circuit switches power to the internal energy source, which preserves data.

The internal coin cell maintains data in the bq4832Y after the initial application of V_{CC} for an accumulated period of at least 10 years when V_{CC} is less than V_{SO} . As system power returns and V_{CC} rises above V_{SO} , the battery is disconnected, and the power supply is switched to external V_{CC} . Write-protection continues for t_{CER} after V_{CC} reaches V_{PFD} to allow for processor stabilization. After t_{CER} , normal RAM operation can resume.

Clock Interface

Reading the Clock

The interface to the clock and control registers of the bq4832Y is the same as that for the general-purpose storage memory. Once every second, the user-accessible clock/calendar locations are updated simultaneously from the internal real time counters. To prevent reading data in transition, updates to the bq4832Y clock registers should be halted. Updating is halted by setting the read bit D6 of the control register to 1. As long as the read bit is 1, updates to user-accessible clock locations are inhibited. Once the frozen clock information is retrieved by reading the appropriate clock memory locations, the read bit should be reset to 0 in order to allow updates to occur from the internal counters. Because the internal counters are not halted by setting the read bit, reading the clock locations has no effect on clock accuracy. Once the read bit is reset to 0, within one second the internal registers update the user-accessible registers with the correct time. A halt command issued during a clock update allows the update to occur before freezing the data.

Table 1. bq4832Y Clock and Control Register Map

Address	D7	D6	D5	D4	D3	D2	D1	D0	Range (h)	Register
7FFF	10 Years				Year				00–99	Year
7FFE	X	X	X	10 Month	Month				01–12	Month
7FFD	X	X	10 Date		Date				01–31	Date
7FFC	X	FTE	X	X	X	Day			01–07	Days
7FFB	X	X	10 Hours		Hours				00–23	Hours
7FFA	X	10 Minutes			Minutes				00–59	Minutes
7FF9	OSC	10 Seconds		Seconds				00–59	Seconds	
7FF8	W	R	S	Calibration				00–31	Control	
7FF7	WDS	BM4	BM3	BM2	BM1	BM0	WD1	WD0		Watchdog
7FF6	AIE	PWRIE	ABE	PIE	RS3	RS2	RS1	RS0		Interrupts
7FF5	ALM3	X	10-date alarm		Alarm date				01–31	Alarm date
7FF4	ALM2	X	10-hour alarm		Alarm hours				00–23	Alarm hours
7FF3	ALM1	Alarm 10 minutes			Alarm minutes				00–59	Alarm minutes
7FF2	ALM0	Alarm 10 seconds			Alarm seconds				00–59	Alarm seconds
7FF1	0.1 seconds				0.01 seconds				00–99	0.1/0.01 seconds
7FF0	WDF	AF	PWRF	BLF	PF	X	X	X		Flags

Notes: X = Unused bits; can be written and read.
 Clock/Calendar data in 24-hour BCD format.
 BLF = 1 for low battery.
 OSC = 1 stops the clock oscillator.
 Interrupt enables are cleared on power-up.

Table 2. Clock and Control Register Bits

Bits	Description
ABE	Alarm interrupt enable in battery-backup mode
AF	Alarm interrupt flag
AIE	Alarm interrupt enable
ALM0–ALM3	Alarm repeat rate
BLF	Battery-low flag
BM0–BM4	Watchdog multiplier
FTE	Frequency test mode enable
OSC	Oscillator stop
PF	Periodic interrupt flag
PIE	Periodic interrupt enable
PWRF	Power-fail interrupt flag
PWRIE	Power-fail interrupt enable
R	Read clock enable
RS0–RS3	Periodic interrupt rate
S	Calibration sign
W	Write clock enable
WD0–WD1	Watchdog resolution
WDF	Watchdog flag
WDS	Watchdog steering

Setting the Clock

Bit D7 of the control register is the write bit. Like the read bit, the write bit when set to a 1 halts updates to the clock/calendar memory locations. Once frozen, the locations can be written with the desired information in 24-hour BCD format. Resetting the write bit to 0 causes the written values to be transferred to the internal clock counters and allows updates to the user-accessible registers to resume within one second. Use the write bit, D7, only when updating the time registers (7FFF-7FF9).

Stopping and Starting the Clock Oscillator

The OSC bit in the seconds register turns the clock on or off. If the bq4832Y is to spend a significant period of time in storage, the clock oscillator can be turned off to preserve battery capacity. OSC set to 1 stops the clock oscillator. When OSC is reset to 0, the clock oscillator is turned on and clock updates to user-accessible memory locations occur within one second.

The OSC bit is set to 1 when shipped from the Benchmarq factory.

Calibrating the Clock

The bq4832Y real-time clock is driven by a quartz controlled oscillator with a nominal frequency of 32,768 Hz. The quartz crystal is contained within the bq4832Y package along with the battery. The clock accuracy of the bq4832Y module is tested to be within 20ppm or about 1 minute per month at 25°C. The oscillation rates of crystals change with temperature as Figure 3 shows. To compensate for the frequency shift, the bq4832Y offers onboard software clock calibration. The user can adjust the calibration based on the typical operating temperature of individual applications.

The software calibration bits are located in the control register. Bits D0–D4 control the magnitude of correction, and bit D5 the direction (positive or negative) of correction. Assuming that the oscillator is running at exactly 32,786 Hz, each calibration step of D0–D4 adjusts the clock rate by +4.068 ppm (+10.7 seconds per month) or -2.034 ppm (-5.35 seconds per month) depending on the value of the sign bit D5. When the sign bit is 1, positive adjustment occurs; a 0 activates negative adjustment. The total range of clock calibration is +5.5 or -2.75 minutes per month.

Two methods can be used to ascertain how much calibration a given bq4832Y may require in a system. The first involves simply setting the clock, letting it run for a month, and then comparing the time to an accurate known reference like WWV radio broadcasts. Based on the variation to the standard, the end user can adjust the clock to match the system’s environment even after the product is packaged in a non-serviceable enclosure. The only requirement is a utility that allows the end user to access the calibration bits in the control register.

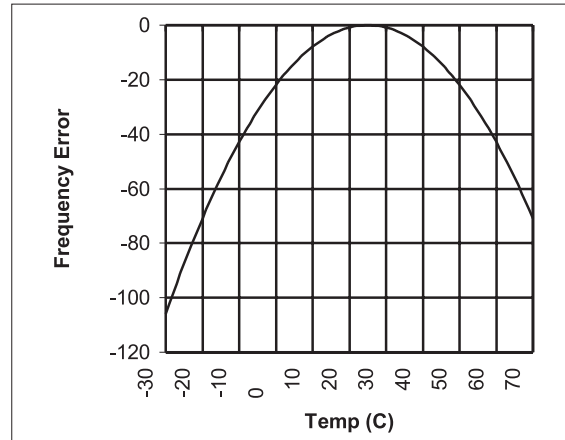

Figure 3. Frequency Error

bq4832Y

The second approach uses a bq4832Y test mode. When the frequency test mode enable bit FTE in the days register is set to a 1, and the oscillator is running at exactly 32,768 Hz, the LSB of the seconds register toggles at 512 Hz. Any deviation from 512 Hz indicates the degree and direction of oscillator frequency shift at the test temperature. For example, a reading of 512.01024 Hz indicates a $(1E6 * 0.01024) / 512$ or +20 ppm oscillator frequency error, requiring ten steps of negative calibration ($10 * -2.034$ or -20.34) or 001010 to be loaded into the calibration byte for correction. To read the test frequency, the bq4832Y must be selected and held in an extended read of the seconds register, location 7FF9, without having the read bit set. The frequency appears on DQ0. The FTE bit must be set using the write bit control. The FTE bit must be reset to 0 for normal clock operation to resume.

Power-On Reset

The bq4832Y provides a power-on reset, which pulls the \overline{RST} pin low on power-down and remains low on power-up for t_{CER} after V_{CC} passes V_{PFD} .

Watchdog Timer

The watchdog circuit monitors the microprocessor's activity. If the processor does not reset the watchdog timer within the programmed time-out period, the circuit asserts the \overline{INT} or \overline{RST} pin. The watchdog timer is activated by writing the desired time-out period into the eight-bit watchdog register described in Table 3 (device address 7FF7). The five bits (BM4–BM0) store a binary multiplier, and the two lower-order bits (WD1–WD0) select the resolution, where 00 = $\frac{1}{16}$ second, 01 = $\frac{1}{4}$ second, 10 = 1 second, and 11 = 4 seconds.

The time-out period is the multiplication of the five-bit multiplier with the two-bit resolution. For example, writing 00011 in BM4–BM0 and 10 in WD1–WD0 results in a total time-out setting of 3×1 or 3 seconds. A multiplier of zero disables the watchdog circuit. Bit 7 of the watchdog register (WDS) is the watchdog steering bit. When WDS is set to a 1 and a time-out occurs, the watchdog asserts a reset pulse for t_{CER} on the \overline{RST} pin. During the reset pulse, the watchdog register is cleared to all zeros disabling the watchdog. When WDS is set to a 0, the watchdog asserts the \overline{INT} pin on a time-out. The \overline{INT} pin remains low until the watchdog is reset by the microprocessor or a power failure occurs. Addition-

ally, when the watchdog times out, the watchdog flag bit (WDF) in the flags register, location 7FF0, is set.

To reset the watchdog timer, the microprocessor must write to the watchdog register. After being reset by a write, the watchdog time-out period starts over. As a precaution, the watchdog circuit is disabled on a power failure. The user must, therefore, set the watchdog at boot-up for activation.

Interrupts

The bq4832Y allows four individually selected interrupt events to generate an interrupt request on the \overline{INT} pin. These four interrupt events are:

- The watchdog timer interrupt, programmable to occur according to the time-out period and conditions described in the watchdog timer section.
- The periodic interrupt, programmable to occur once every 122 μ s to 500ms.
- The alarm interrupt, programmable to occur once per second to once per month.
- The power-fail interrupt, which can be enabled to be asserted when the bq4832Y detects a power failure.

The periodic, alarm, and power-fail interrupts are enabled by an individual interrupt-enable bit in register 7FF6, the interrupts register. When an event occurs, its event flag bit in the flags register, location 7FF0, is set. If the corresponding event enable bit is also set, then an interrupt request is generated. Reading the flags register clears all flag bits and makes \overline{INT} high impedance. To reset the flag register, the bq4832Y addresses must be held stable at location 7FF0 for at least 50ns to avoid inadvertent resets.

Periodic Interrupt

Bits RS3–RS0 in the interrupts register program the rate for the periodic interrupt. The user can interpret the interrupt in two ways: either by polling the flags register for PF assertion or by setting PIE so that \overline{INT} goes active when the bq4832Y sets the periodic flag. Reading the flags register resets the PF bit and returns \overline{INT} to the high-impedance state. Table 4 shows the periodic rates.

Table 3. Watchdog Register Bits

MSB		Bits						LSB	
7	6	5	4	3	2	1	0		
WDS	BM4	BM3	BM2	BM1	BM0	WD1	WD0		

Sept. 1996 C

Table 4. Periodic Rates

RS3	RS2	RS1	RS0	Interrupt Rate
0	0	0	0	None
0	0	0	1	10ms
0	0	1	0	100ms
0	0	1	1	122.07 μ s
0	1	0	0	244.14 μ s
0	1	0	1	488.281 μ s
0	1	1	0	976.5625
0	1	1	1	1.953125ms
1	0	0	0	3.90625ms
1	0	0	1	7.8125ms
1	0	1	0	15.625ms
1	0	1	1	31.25ms
1	1	0	0	62.5ms
1	1	0	1	125ms
1	1	1	0	250ms
1	1	1	1	500ms

Alarm Interrupt

Registers 7FF5–7FF2 program the real-time clock alarm. During each update cycle, the bq4832Y compares the date, hours, minutes, and seconds in the clock registers with the corresponding alarm registers. If a match between all the corresponding bytes is found, the alarm flag AF in the flags register is set. If the alarm interrupt is enabled with AIE, an interrupt request is generated on INT. The alarm condition is cleared by a read to the flags register. ALM3–ALM0 puts the alarm into a periodic mode of operation. Table 5 describes the selectable rates.

Table 5. Alarm Frequency (Alarm Bits DQ7 of Alarm Registers)

ALM3	ALM2	ALM1	ALM0	Alarm Frequency
1	1	1	1	Once per second
1	1	1	0	Once per minute when seconds match
1	1	0	0	Once per hour when minutes, and seconds match
1	0	0	0	Once per day when hours, minutes, and seconds match
0	0	0	0	When date, hours, minutes, and seconds match

The alarm interrupt can be made active while the bq4832Y is in the battery-backup mode by setting ABE in the interrupts register. Normally, the INT pin tristates during battery backup. With ABE set, however, INT is driven low if an alarm condition occurs and the AIE bit is set. Because the AIE bit is reset during power-on reset, an alarm generated during power-on reset updates only the flags register. The user can read the flags register during boot-up to determine if an alarm was generated during power-on reset.

Power-Fail Interrupt

When V_{CC} falls to the power-fail-detect point, the power-fail flag PWRF is set. If the power-fail interrupt enable bit (PWRIE) is also set, then INT is asserted low. The power-fail interrupt occurs t_{WPT} before the bq4832Y generates a reset and deselects. The PWRIE bit is cleared on power-up.

Battery-Low Warning

The bq4832Y checks the internal battery on power-up. If the battery voltage is below 2.2V, the battery-low flag BLF in the flags register is set to a 1 indicating that clock and RAM data may be invalid.

bq4832Y

Absolute Maximum Ratings

Symbol	Parameter	Value	Unit	Conditions
V _{CC}	DC voltage applied on V _{CC} relative to V _{SS}	-0.3 to 7.0	V	
V _T	DC voltage applied on any pin excluding V _{CC} relative to V _{SS}	-0.3 to 7.0	V	V _T ≤ V _{CC} + 0.3
T _{OPR}	Operating temperature	0 to +70	°C	
T _{STG}	Storage temperature (V _{CC} off; oscillator off)	-40 to +70	°C	
T _{BIAS}	Temperature under bias	-10 to +70	°C	
T _{SOLDER}	Soldering temperature	+260	°C	For 10 seconds

Note: Permanent device damage may occur if **Absolute Maximum Ratings** are exceeded. Functional operation should be limited to the Recommended DC Operating Conditions detailed in this data sheet. Exposure to conditions beyond the operational limits for extended periods of time may affect device reliability.

Recommended DC Operating Conditions (T_A = T_{OPR})

Symbol	Parameter	Minimum	Typical	Maximum	Unit	Notes
V _{CC}	Supply voltage	4.5	5.0	5.5	V	
V _{SS}	Supply voltage	0	0	0	V	
V _{IL}	Input low voltage	-0.3	-	0.8	V	
V _{IH}	Input high voltage	2.2	-	V _{CC} + 0.3	V	

Note: Typical values indicate operation at T_A = 25°C.

DC Electrical Characteristics ($T_A = T_{OPR}$, $V_{CCmin} \leq V_{CC} \leq V_{CCmax}$)

Symbol	Parameter	Minimum	Typical	Maximum	Unit	Conditions/Notes
I _{LI}	Input leakage current	-	-	± 1	μA	V _{IN} = V _{SS} to V _{CC}
I _{LO}	Output leakage current	-	-	± 1	μA	$\overline{CE} = V_{IH}$ or $\overline{OE} = V_{IH}$ or $\overline{WE} = V_{IL}$
V _{OH}	Output high voltage	2.4	-	-	V	I _{OH} = -1.0 mA
V _{OL}	Output low voltage	-	-	0.4	V	I _{OL} = 2.1 mA
I _{OD}	\overline{RST} , \overline{INT} sink current	10	-	-	mA	V _{OL} = 0.4V
I _{SB1}	Standby supply current	-	3	6	mA	$\overline{CE} = V_{IH}$
I _{SB2}	Standby supply current	-	2	4	mA	$\overline{CE} \geq V_{CC} - 0.2V$, 0V ≤ V _{IN} ≤ 0.2V, or V _{IN} ≥ V _{CC} - 0.2V
I _{CC}	Operating supply current	-	55	75	mA	Min. cycle, duty = 100%, $\overline{CE} = V_{IL}$, I _{I/O} = 0mA
V _{PFD}	Power-fail-detect voltage	4.30	4.37	4.50	V	
V _{SO}	Supply switch-over voltage	-	3	-	V	

Notes: Typical values indicate operation at T_A = 25°C, V_{CC} = 5V.
 \overline{RST} and \overline{INT} are open-drain outputs.

Capacitance (T_A = 25°C, F = 1MHz, V_{CC} = 5.0V)

Symbol	Parameter	Minimum	Typical	Maximum	Unit	Conditions
C _{I/O}	Input/output capacitance	-	-	10	pF	Output voltage = 0V
C _{IN}	Input capacitance	-	-	10	pF	Input voltage = 0V

Note: These parameters are sampled and not 100% tested.

bq4832Y

AC Test Conditions

Parameter	Test Conditions
Input pulse levels	0V to 3.0V
Input rise and fall times	5 ns
Input and output timing reference levels	1.5 V (unless otherwise specified)
Output load (including scope and jig)	See Figures 4 and 5

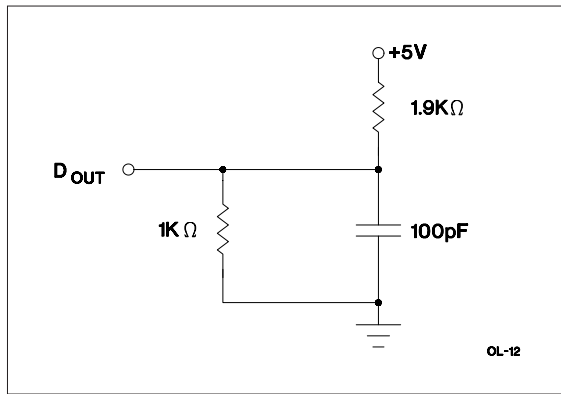

Figure 4. Output Load A

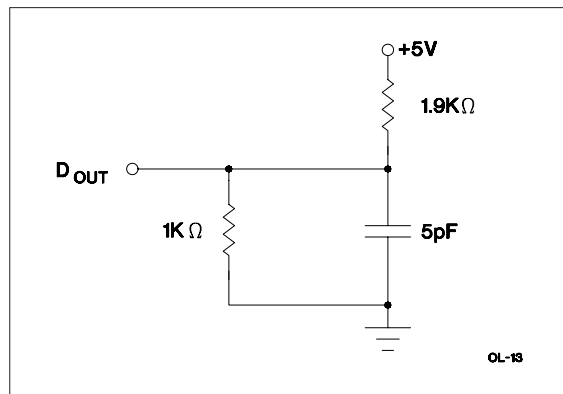
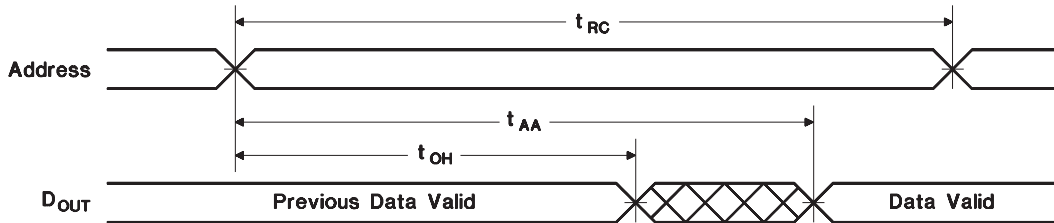

Figure 5. Output Load B

Read Cycle ($T_A = T_{OPR}$, $V_{CCmin} \leq V_{CC} \leq V_{CCmax}$)

Symbol	Parameter	-85		Unit	Conditions
		Min.	Max.		
t _{RC}	Read cycle time	85	-	ns	
t _{AA}	Address access time	-	85	ns	Output load A
t _{ACE}	Chip enable access time	-	85	ns	Output load A
t _{OE}	Output enable to output valid	-	45	ns	Output load A
t _{CLZ}	Chip enable to output in low Z	5	-	ns	Output load B
t _{OLZ}	Output enable to output in low Z	0	-	ns	Output load B
t _{CHZ}	Chip disable to output in high Z	0	35	ns	Output load B
t _{OHZ}	Output disable to output in high Z	0	25	ns	Output load B
t _{OH}	Output hold from address change	10	-	ns	Output load A

Read Cycle No. 1 (Address Access) ^{1,2}



RC-1

Read Cycle No. 2 (CE Access) ^{1,3,4}

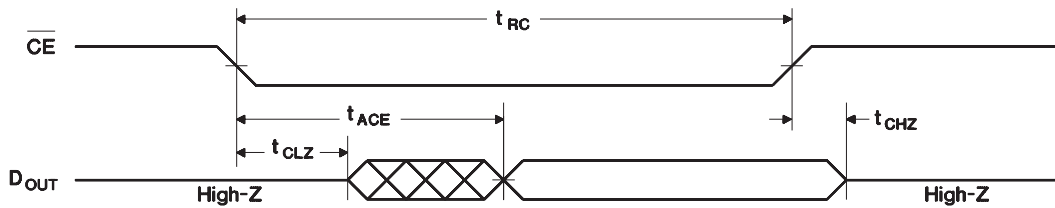

RC-2

Read Cycle No. 3 (OE Access) ^{1,5}

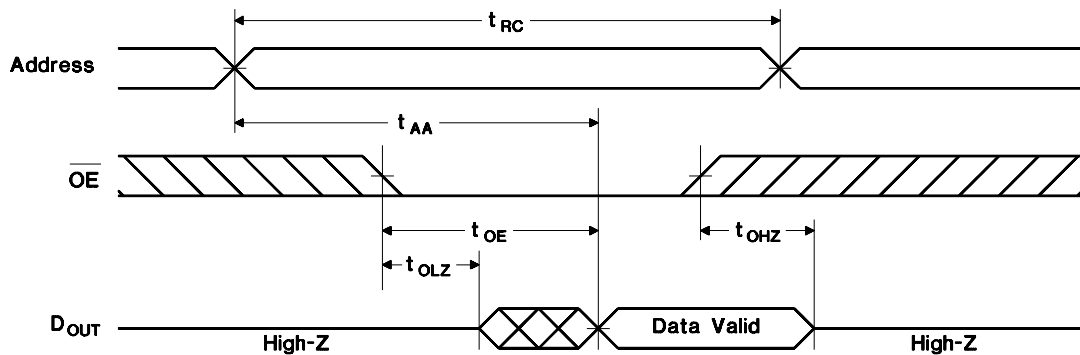

RC-3

- Notes:**
1. \overline{WE} is held high for a read cycle.
 2. Device is continuously selected: $\overline{CE} = \overline{OE} = V_{IL}$.
 3. Address is valid prior to or coincident with \overline{CE} transition low.
 4. $\overline{OE} = V_{IL}$.
 5. Device is continuously selected: $\overline{CE} = V_{IL}$.

bq4832Y

Write Cycle ($T_A = T_{OPR}$, $V_{CCmin} \leq V_{CC} \leq V_{CCmax}$)

Symbol	Parameter	-85		Units	Conditions/Notes
		Min.	Max.		
t _{WC}	Write cycle time	85	-	ns	
t _{CW}	Chip enable to end of write	75	-	ns	(1)
t _{AW}	Address valid to end of write	75	-	ns	(1)
t _{AS}	Address setup time	0	-	ns	Measured from address valid to beginning of write. (2)
t _{WP}	Write pulse width	65	-	ns	Measured from beginning of write to end of write. (1)
t _{WR1}	Write recovery time (write cycle 1)	5	-	ns	Measured from \overline{WE} going high to end of write cycle. (3)
t _{WR2}	Write recovery time (write cycle 2)	15	-	ns	Measured from \overline{CE} going high to end of write cycle. (3)
t _{DW}	Data valid to end of write	35	-	ns	Measured to first low-to-high transition of either \overline{CE} or \overline{WE} .
t _{DH1}	Data hold time (write cycle 1)	0	-	ns	Measured from \overline{WE} going high to end of write cycle. (4)
t _{DH2}	Data hold time (write cycle 2)	10	-	ns	Measured from \overline{CE} going high to end of write cycle. (4)
t _{WZ}	Write enabled to output in high Z	0	30	ns	I/O pins are in output state. (5)
t _{OW}	Output active from end of write	0	-	ns	I/O pins are in output state. (5)

- Notes:**
1. A write ends at the earlier transition of \overline{CE} going high and \overline{WE} going high.
 2. A write occurs during the overlap of a low \overline{CE} and a low \overline{WE} . A write begins at the later transition of \overline{CE} going low and \overline{WE} going low.
 3. Either t_{WR1} or t_{WR2} must be met.
 4. Either t_{DH1} or t_{DH2} must be met.
 5. If \overline{CE} goes low simultaneously with \overline{WE} going low or after \overline{WE} going low, the outputs remain in high-impedance state.

Write Cycle No. 1 (WE-Controlled) ^{1,2,3}

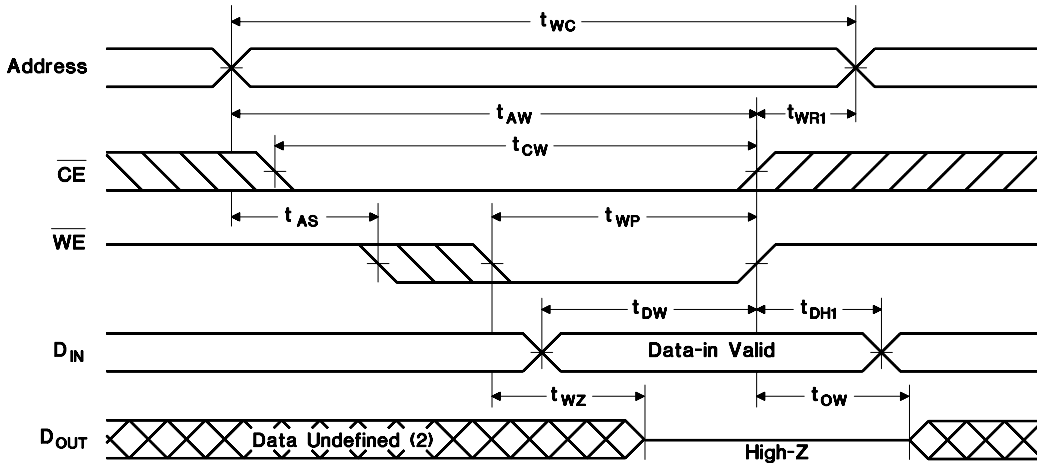

WC-14

Write Cycle No. 2 (CE-Controlled) ^{1,2,3,4,5}

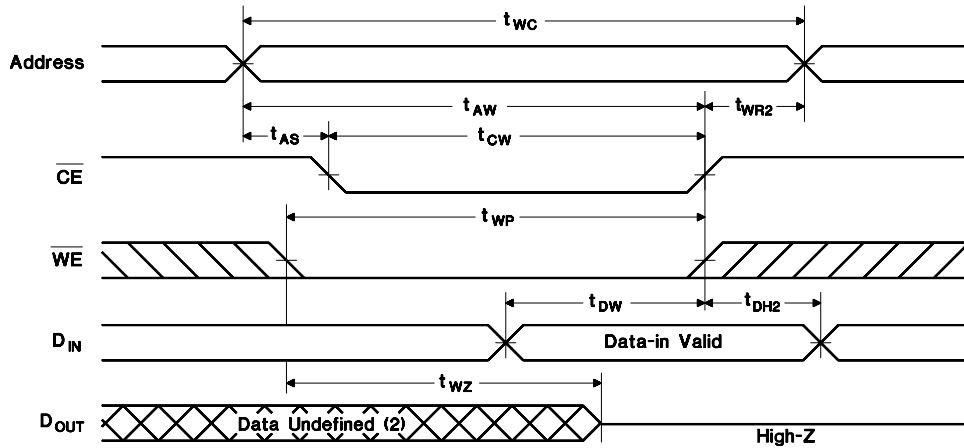

WC-15

- Notes:**
1. \overline{CE} or \overline{WE} must be high during address transition.
 2. Because I/O may be active (\overline{OE} low) during this period, data input signals of opposite polarity to the outputs must not be applied.
 3. If \overline{OE} is high, the I/O pins remain in a state of high impedance.
 4. Either t_{wr1} or t_{wr2} must be met.
 5. Either t_{dh1} or t_{dh2} must be met.

bq4832Y

Power-Down/Power-Up Cycle ($T_A = T_{OPR}$)

Symbol	Parameter	Minimum	Typical	Maximum	Unit	Conditions
t_{PF}	V_{CC} slew, 4.50 to 4.20 V	300	-	-	μs	
t_{FS}	V_{CC} slew, 4.20 to V_{SO}	10	-	-	μs	
t_{PU}	V_{CC} slew, V_{SO} to V_{PFD} (max.)	0	-	-	μs	
t_{CER}	Chip enable recovery time	40	100	200	ms	Time during which SRAM is write-protected after V_{CC} passes V_{PFD} on power-up.
t_{DR}	Data-retention time in absence of V_{CC}	10	-	-	years	$T_A = 25^\circ\text{C}$. (2)
t_{WPT}	Write-protect time	40	100	160	μs	Delay after V_{CC} slews down past V_{PFD} before SRAM is write-protected.

- Notes:**
1. Typical values indicate operation at $T_A = 25^\circ\text{C}$, $V_{CC} = 5\text{V}$.
 2. Battery is disconnected from circuit until after V_{CC} is applied for the first time. t_{DR} is the accumulated time in absence of power beginning when power is first applied to the device.

Caution: Negative undershoots below the absolute maximum rating of -0.3V in battery-backup mode may affect data integrity.

Power-Down/Power-Up Timing

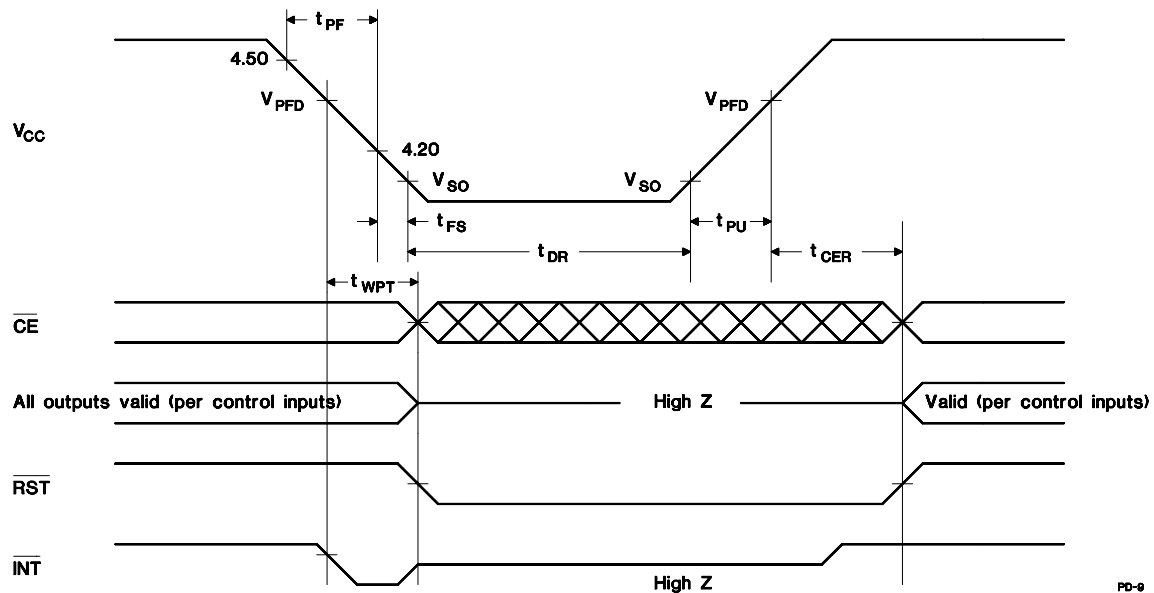

- Notes:**
1. $\overline{\text{PWRIE}}$ is set to "1" to enable power fail interrupt.
 2. $\overline{\text{RST}}$ and $\overline{\text{INT}}$ are open drain and require an external pull-up resistor.

Data Sheet Revision History

Change No.	Page No.	Description
1	4	Corrected the locations of bits D6 and D4 of the Interrupts Register and the corresponding bits D5 and D3 of the Flags Register (these were reversed).
2	4	Corrected the alarm date register (7FF5) to allow for 01-31 days in a month instead of 01-07 days.
2	9	Lowered I _{SB1} from 4, 7mA to 3, 6mA; lowered I _{SB2} typical from 2.5mA to 2mA.

Notes: Change 1 = Mar. 1996 B changes from Oct. 1995 A.
Change 2 = Sept. 1996 C changes from Mar. 1996 B.

bq4832Y

MA: 32-Pin A-Type Module

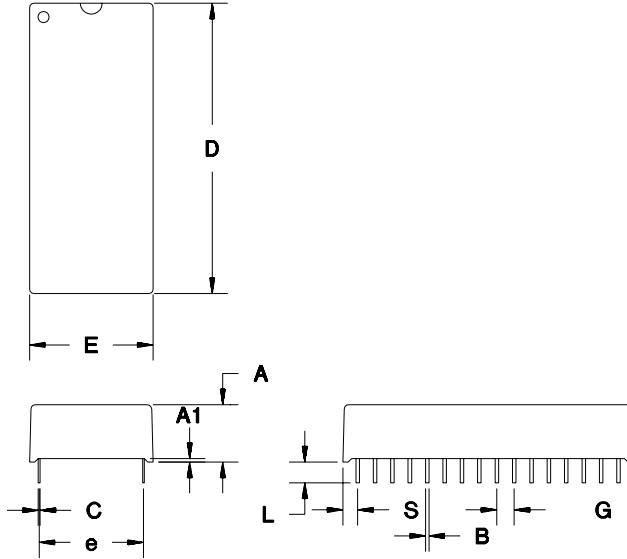

32-Pin MA (A-Type Module)

Dimension	Inches		Millimeters	
	Min.	Max.	Min.	Max.
A	0.365	0.375	9.27	9.53
A1	0.015	-	0.38	-
B	0.017	0.023	0.43	0.58
C	0.008	0.013	0.20	0.33
D	1.670	1.700	42.42	43.18
E	0.710	0.740	18.03	18.80
e	0.590	0.630	14.99	16.00
G	0.090	0.110	2.29	2.79
L	0.120	0.150	3.05	3.81
S	0.075	0.110	1.91	2.79

Ordering Information

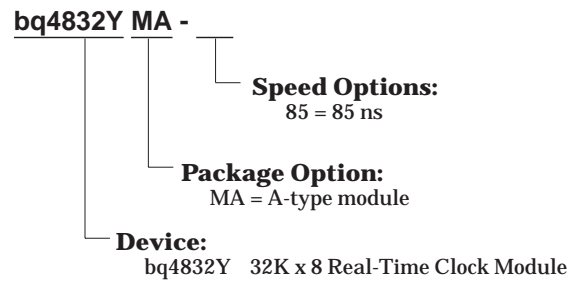

PACKAGING INFORMATION

Orderable Device	Status (1)	Package Type	Package Drawing	Pins	Package Qty	Eco Plan (2)	Lead/Ball Finish (6)	MSL Peak Temp (3)	Op Temp (°C)	Device Marking (4/5)	Samples
BQ4832YMA-85	OBSOLETE	DIP MODULE	MA	32		TBD	Call TI	Call TI	0 to 70		

(1) The marketing status values are defined as follows:

ACTIVE: Product device recommended for new designs.

LIFEBUY: TI has announced that the device will be discontinued, and a lifetime-buy period is in effect.

NRND: Not recommended for new designs. Device is in production to support existing customers, but TI does not recommend using this part in a new design.

PREVIEW: Device has been announced but is not in production. Samples may or may not be available.

OBSOLETE: TI has discontinued the production of the device.

(2) Eco Plan - The planned eco-friendly classification: Pb-Free (RoHS), Pb-Free (RoHS Exempt), or Green (RoHS & no Sb/Br) - please check <http://www.ti.com/productcontent> for the latest availability information and additional product content details.

TBD: The Pb-Free/Green conversion plan has not been defined.

Pb-Free (RoHS): TI's terms "Lead-Free" or "Pb-Free" mean semiconductor products that are compatible with the current RoHS requirements for all 6 substances, including the requirement that lead not exceed 0.1% by weight in homogeneous materials. Where designed to be soldered at high temperatures, TI Pb-Free products are suitable for use in specified lead-free processes.

Pb-Free (RoHS Exempt): This component has a RoHS exemption for either 1) lead-based flip-chip solder bumps used between the die and package, or 2) lead-based die adhesive used between the die and leadframe. The component is otherwise considered Pb-Free (RoHS compatible) as defined above.

Green (RoHS & no Sb/Br): TI defines "Green" to mean Pb-Free (RoHS compatible), and free of Bromine (Br) and Antimony (Sb) based flame retardants (Br or Sb do not exceed 0.1% by weight in homogeneous material)

(3) MSL, Peak Temp. - The Moisture Sensitivity Level rating according to the JEDEC industry standard classifications, and peak solder temperature.

(4) There may be additional marking, which relates to the logo, the lot trace code information, or the environmental category on the device.

(5) Multiple Device Markings will be inside parentheses. Only one Device Marking contained in parentheses and separated by a "~" will appear on a device. If a line is indented then it is a continuation of the previous line and the two combined represent the entire Device Marking for that device.

(6) Lead/Ball Finish - Orderable Devices may have multiple material finish options. Finish options are separated by a vertical ruled line. Lead/Ball Finish values may wrap to two lines if the finish value exceeds the maximum column width.

Important Information and Disclaimer: The information provided on this page represents TI's knowledge and belief as of the date that it is provided. TI bases its knowledge and belief on information provided by third parties, and makes no representation or warranty as to the accuracy of such information. Efforts are underway to better integrate information from third parties. TI has taken and continues to take reasonable steps to provide representative and accurate information but may not have conducted destructive testing or chemical analysis on incoming materials and chemicals. TI and TI suppliers consider certain information to be proprietary, and thus CAS numbers and other limited information may not be available for release.

In no event shall TI's liability arising out of such information exceed the total purchase price of the TI part(s) at issue in this document sold by TI to Customer on an annual basis.

IMPORTANT NOTICE

Texas Instruments Incorporated and its subsidiaries (TI) reserve the right to make corrections, enhancements, improvements and other changes to its semiconductor products and services per JESD46, latest issue, and to discontinue any product or service per JESD48, latest issue. Buyers should obtain the latest relevant information before placing orders and should verify that such information is current and complete. All semiconductor products (also referred to herein as "components") are sold subject to TI's terms and conditions of sale supplied at the time of order acknowledgment.

TI warrants performance of its components to the specifications applicable at the time of sale, in accordance with the warranty in TI's terms and conditions of sale of semiconductor products. Testing and other quality control techniques are used to the extent TI deems necessary to support this warranty. Except where mandated by applicable law, testing of all parameters of each component is not necessarily performed.

TI assumes no liability for applications assistance or the design of Buyers' products. Buyers are responsible for their products and applications using TI components. To minimize the risks associated with Buyers' products and applications, Buyers should provide adequate design and operating safeguards.

TI does not warrant or represent that any license, either express or implied, is granted under any patent right, copyright, mask work right, or other intellectual property right relating to any combination, machine, or process in which TI components or services are used. Information published by TI regarding third-party products or services does not constitute a license to use such products or services or a warranty or endorsement thereof. Use of such information may require a license from a third party under the patents or other intellectual property of the third party, or a license from TI under the patents or other intellectual property of TI.

Reproduction of significant portions of TI information in TI data books or data sheets is permissible only if reproduction is without alteration and is accompanied by all associated warranties, conditions, limitations, and notices. TI is not responsible or liable for such altered documentation. Information of third parties may be subject to additional restrictions.

Resale of TI components or services with statements different from or beyond the parameters stated by TI for that component or service voids all express and any implied warranties for the associated TI component or service and is an unfair and deceptive business practice. TI is not responsible or liable for any such statements.

Buyer acknowledges and agrees that it is solely responsible for compliance with all legal, regulatory and safety-related requirements concerning its products, and any use of TI components in its applications, notwithstanding any applications-related information or support that may be provided by TI. Buyer represents and agrees that it has all the necessary expertise to create and implement safeguards which anticipate dangerous consequences of failures, monitor failures and their consequences, lessen the likelihood of failures that might cause harm and take appropriate remedial actions. Buyer will fully indemnify TI and its representatives against any damages arising out of the use of any TI components in safety-critical applications.

In some cases, TI components may be promoted specifically to facilitate safety-related applications. With such components, TI's goal is to help enable customers to design and create their own end-product solutions that meet applicable functional safety standards and requirements. Nonetheless, such components are subject to these terms.

No TI components are authorized for use in FDA Class III (or similar life-critical medical equipment) unless authorized officers of the parties have executed a special agreement specifically governing such use.

Only those TI components which TI has specifically designated as military grade or "enhanced plastic" are designed and intended for use in military/aerospace applications or environments. Buyer acknowledges and agrees that any military or aerospace use of TI components which have **not** been so designated is solely at the Buyer's risk, and that Buyer is solely responsible for compliance with all legal and regulatory requirements in connection with such use.

TI has specifically designated certain components as meeting ISO/TS16949 requirements, mainly for automotive use. In any case of use of non-designated products, TI will not be responsible for any failure to meet ISO/TS16949.

Products

Audio	www.ti.com/audio
Amplifiers	amplifier.ti.com
Data Converters	dataconverter.ti.com
DLP® Products	www.dlp.com
DSP	dsp.ti.com
Clocks and Timers	www.ti.com/clocks
Interface	interface.ti.com
Logic	logic.ti.com
Power Mgmt	power.ti.com
Microcontrollers	microcontroller.ti.com
RFID	www.ti-rfid.com
OMAP Applications Processors	www.ti.com/omap
Wireless Connectivity	www.ti.com/wirelessconnectivity

Applications

Automotive and Transportation	www.ti.com/automotive
Communications and Telecom	www.ti.com/communications
Computers and Peripherals	www.ti.com/computers
Consumer Electronics	www.ti.com/consumer-apps
Energy and Lighting	www.ti.com/energy
Industrial	www.ti.com/industrial
Medical	www.ti.com/medical
Security	www.ti.com/security
Space, Avionics and Defense	www.ti.com/space-avionics-defense
Video and Imaging	www.ti.com/video

TI E2E Community

e2e.ti.com

Looking for pricing, stock, or lifecycle information?

Click below to explore more details on WIN SOURCE:

 [View BQ4832YMA-85](#) on WIN SOURCE

 [Texas Instruments](#) Information

Optimize Your Supply Chain with WIN SOURCE Solutions

-  Global Sourcing Solution
-  Obsolete Management
-  Cost Control Management
-  Shortage Management
-  Alternative Solution
-  Excess Inventory Management