

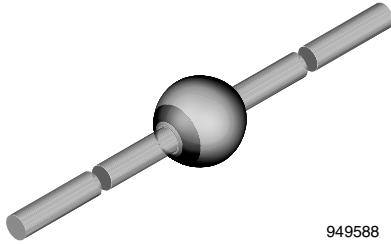

**THE DATASHEET OF
BZW03C180-TAP**



Zener Diodes with Surge Current Specification



949588

FEATURES

- Glass passivated junction
- Hermetically sealed package
- Clamping time in picoseconds
- Material categorization:
For definitions of compliance please see www.vishay.com/doc?99912

RoHS
 COMPLIANT
 HALOGEN
FREE

APPLICATIONS

- Voltage regulators and transient suppression
- Circuits

PRIMARY CHARACTERISTICS

PARAMETER	VALUE	UNIT
V _Z range nom.	6.8 to 270	V
Test current I _{ZT}	5 to 175	mA
V _Z specification	Pulse current	
Int. construction	Single	

ORDERING INFORMATION (Example)

DEVICE NAME	ORDERING CODE	TAPED UNITS	MINIMUM ORDER QUANTITY
BZW03C6V8	BZW03C6V8-TR	2500 per 10" tape and reel	12 500
BZW03C6V8	BZW03C6V8-TAP	2500 per ammpack	12 500

PACKAGE

PACKAGE NAME	WEIGHT	MOLDING COMPOUND FLAMMABILITY RATING	MOISTURE SENSITIVITY LEVEL	SOLDERING CONDITIONS
SOD-64	858 mg	UL 94 V-0	MSL level 1 (according J-STD-020)	260 °C/10 s at terminals

ABSOLUTE MAXIMUM RATINGS (T_{amb} = 25 °C, unless otherwise specified)

PARAMETER	TEST CONDITION	SYMBOL	VALUE	UNIT
Power dissipation	I = 10 mm, T _L = 25 °C	P _{tot}	6000	mW
	T _{amb} = 45 °C	P _{tot}	1850	
Repetitive peak reverse power dissipation		P _{ZRM}	20	W
Non repetitive peak surge power dissipation	t _p = 100 μs, T _j = 25 °C	P _{ZSM}	1000	W
Junction to ambient air	I = 25 mm, T _L = constant	R _{thJA}	30	K/W
	On PC board with spacing 37.5 mm	R _{thJA}	70	
Junction temperature		T _J	175	°C
Storage temperature range		T _{stg}	- 65 to + 175	°C
Forward voltage (max.)	I _F = 1 A	V _F	1.2	V



ELECTRICAL CHARACTERISTICS ($T_{amb} = 25\text{ }^{\circ}\text{C}$, unless otherwise specified)														
PART NUMBER	ZENER VOLTAGE RANGE			TEST CURRENT	REVERSE LEAKAGE CURRENT		DYNAMIC RESISTANCE		TEMPERATURE COEFFICIENT		CLAMPING ⁽¹⁾		STAND OFF ⁽²⁾	
	V _Z at I _{ZT1}			I _{ZT1}	I _R at V _R		Z _Z at I _{ZT1}		TC _{VZ} at I _{ZT1}		V _{(CL)R} at I _{RMS}		I _R at V _R	
	V			mA	μA	V	Ω		%K		V	A	μA	V
	MIN.	NOM.	MAX.		MAX.		TYP.	MAX.	MIN.	MAX.	MAX.		MAX.	
BZW03C6V8	6.4	6.8	7.2	175	2000	5.1	0.7	1.5	0	0.07	10.3	48.5	4000	5.6
BZW03C7V5	7	7.5	7.9	175	1500	5.6	0.7	1.5	0	0.07	11.3	44.2	3000	6.2
BZW03C8V2	7.7	8.2	8.7	150	1200	6.2	0.8	1.5	0.03	0.08	12.3	40.6	2400	6.8
BZW03C9V1	8.5	9.1	9.6	150	40	6.8	0.9	2	0.03	0.08	13.3	37.6	100	7.5
BZW03C10	9.4	10	10.6	125	20	7.5	1	2	0.05	0.09	14.8	34	40	8.2
BZW03C11	10.4	11	11.6	125	15	8.2	1.1	2.5	0.05	0.1	15.7	31.8	30	9.1
BZW03C12	11.4	12	12.7	100	10	9.1	1.1	2.5	0.05	0.1	17	29.4	20	10
BZW03C13	12.4	14	14.1	100	4	10	1.2	2.5	0.05	0.1	18.9	26.4	10	11
BZW03C15	13.8	15	15.6	75	2	11	1.2	2.5	0.05	0.1	20.9	23.9	10	12
BZW03C16	15.3	16	17.1	75	2	12	1.3	2.5	0.06	0.11	22.9	21.8	10	13
BZW03C18	16.8	18	19.1	65	2	13	1.3	2.5	0.06	0.11	25.6	19.5	10	15
BZW03C20	18.8	20	21.2	65	2	15	1.5	3	0.06	0.11	28.4	17.6	10	16
BZW03C22	20.8	22	23.3	50	2	16	1.6	3.5	0.06	0.11	31	16.1	10	18
BZW03C24	22.8	24	25.6	50	2	18	1.8	3.5	0.06	0.11	33.8	14.8	10	20
BZW03C27	25.1	27	28.9	50	2	20	2.5	5	0.06	0.11	38.1	13.1	10	22
BZW03C30	28	30	32	40	2	22	4	8	0.06	0.11	42.2	11.8	10	24
BZW03C33	31	33	35	40	2	24	5	10	0.06	0.11	46.2	10.8	10	27
BZW03C36	34	36	38	30	2	27	6	11	0.06	0.11	50.1	10	10	30
BZW03C39	37	39	41	30	2	30	7	14	0.06	0.11	54.1	9.2	10	33
BZW03C43	40	43	46	30	2	33	10	20	0.07	0.12	60.7	8.2	10	36
BZW03C47	44	47	50	25	2	36	12	25	0.07	0.12	65.5	7.6	10	39
BZW03C51	48	51	54	25	2	39	14	27	0.07	0.12	70.8	7	10	43
BZW03C56	52	56	60	20	2	43	18	35	0.07	0.12	78.6	6.3	10	47
BZW03C62	58	62	66	20	2	47	20	42	0.08	0.13	86.5	5.8	10	51
BZW03C68	64	68	72	20	2	51	22	44	0.08	0.13	94.4	5.3	10	56
BZW03C75	70	75	79	20	2	56	25	45	0.08	0.13	103.5	4.8	10	62
BZW03C82	77	82	87	15	2	62	30	65	0.08	0.13	114	4.3	10	68
BZW03C91	85	91	96	15	2	68	40	75	0.09	0.13	126	3.9	10	75
BZW03C100	94	100	106	12	2	75	45	90	0.09	0.13	139	3.6	10	82
BZW03C110	104	110	116	12	2	82	65	125	0.09	0.13	152	3.3	10	91
BZW03C120	114	120	127	10	2	91	90	170	0.09	0.13	167	3	10	100
BZW03C130	124	130	141	10	2	100	100	190	0.09	0.13	185	2.7	10	110
BZW03C150	138	150	156	8	2	110	150	330	0.09	0.13	204	2.4	10	120
BZW03C160	153	160	171	8	2	120	180	350	0.09	0.13	224	2.2	10	130
BZW03C180	168	180	191	5	2	130	210	430	0.09	0.13	249	2	10	150
BZW03C200	188	200	212	5	2	150	250	500	0.09	0.13	276	1.8	10	160
BZW03C220	208	220	233	5	2	160	350	700	0.09	0.13	305	1.6	10	180
BZW03C240	228	240	256	5	2	180	450	900	0.09	0.13	336	1.5	10	200
BZW03C270	251	270	289	5	2	200	600	1200	0.09	0.13	380	1.3	10	220

Notes

- (1) Exp. falling pulse, t_p = 500 μs down to 37 %
- (2) Stand-off reverse voltage = recommended supply voltage



ELECTRICAL CHARACTERISTICS ($T_{amb} = 25\text{ }^{\circ}\text{C}$, unless otherwise specified)														
PART NUMBER	ZENER VOLTAGE RANGE			TEST CURRENT	REVERSE LEAKAGE CURRENT		DYNAMIC RESISTANCE		TEMPERATURE COEFFICIENT		CLAMPING ⁽¹⁾		STAND OFF ⁽²⁾	
	V_Z at I_{ZT1}			I_{ZT1}	I_R at V_R		Z_Z at I_{ZT1}		TC_{VZ} at I_{ZT1}		$V_{(CL)R}$ at I_{RMS}		I_R at V_R	
	V			mA	μA	V	Ω		%/K		V	A	μA	V
	MIN.	NOM.	MAX.		MAX.		TYP.	MAX.	MIN.	MAX.	MAX.		MAX.	
BZW03D6V8	6.1	6.8	7.5	175	2000	4.8	0.7	1.5	0	0.07	10.6	48.5	4000	5.3
BZW03D7V5	6.75	7.5	8.25	175	1500	5.3	0.7	1.5	0	0.07	11.7	44.2	3000	5.8
BZW03D8V2	7.4	8.2	9	150	1200	5.8	0.8	1.5	0.03	0.08	12.6	40.6	2400	6.5
BZW03D9V1	8.2	9.1	10	150	40	6.5	0.9	2	0.03	0.08	13.6	37.6	100	7.1
BZW03D10	9	10	11	125	20	7.1	1	2	0.05	0.09	15.2	34	40	7.9
BZW03D11	9.9	11	12.1	125	15	7.9	1.1	2.5	0.05	0.1	16.2	31.8	30	8.6
BZW03D12	10.8	12	13.2	100	10	8.6	1.1	2.5	0.05	0.1	17.5	29.4	20	9.3
BZW03D13	11.7	13	14.3	100	4	9.3	1.2	2.5	0.05	0.1	19.1	26.4	10	10.6
BZW03D15	13.5	15	16.5	75	2	10.6	1.2	2.5	0.05	0.1	21.8	23.9	10	11.6
BZW03D16	14.4	16	17.6	75	2	11.6	1.3	2.5	0.06	0.11	23.4	21.8	10	12.6
BZW03D18	16.2	18	19.8	65	2	12.6	1.3	2.5	0.06	0.11	26.3	19.5	10	14.4
BZW03D20	18	20	22	65	2	14.4	1.5	3	0.06	0.11	29.2	17.6	10	15.8
BZW03D22	20.8	22	24.2	50	2	15.8	1.6	3.5	0.06	0.11	32	16.1	10	17.2
BZW03D24	21.6	24	26.4	50	2	17.2	1.8	3.5	0.06	0.11	34.6	14.8	10	19.4
BZW03D27	24.3	27	29.7	50	2	19.4	2.5	5	0.06	0.11	39	13.1	10	21.5
BZW03D30	27	30	33	40	2	21.5	4	8	0.06	0.11	43.2	11.8	10	23.5
BZW03D33	29.7	33	36.3	40	2	23.5	5	10	0.06	0.11	47	10.8	10	25.8
BZW03D36	32.4	36	39.6	30	2	25.8	6	11	0.06	0.11	51.7	10	10	28
BZW03D39	25.1	39	42.9	30	2	28	7	14	0.06	0.11	56	9.2	10	31
BZW03D43	38.7	43	47.3	30	2	31	10	20	0.07	0.12	62	8.2	10	33.5
BZW03D47	42.3	47	51.7	25	2	33.5	12	25	0.07	0.12	66.7	7.6	10	36.5
BZW03D51	45.9	51	56.1	25	2	36.5	14	27	0.07	0.12	73	7	10	40
BZW03D56	50.4	56	61.6	20	2	40	18	35	0.07	0.12	80.2	6.3	10	44.5
BZW03D62	55.8	62	68.2	20	2	44.5	20	42	0.08	0.13	88.7	5.8	10	49
BZW03D68	61.2	68	74.8	20	2	49	22	44	0.08	0.13	97.2	5.3	10	54
BZW03D75	67.5	75	82.5	20	2	54	25	45	0.08	0.13	107	4.8	10	59
BZW03D82	73.8	82	90.2	15	2	59	30	65	0.08	0.13	117	4.3	10	65
BZW03D91	81.9	91	100	15	2	65	40	75	0.09	0.13	130	3.9	10	71
BZW03D100	90	100	110	12	2	71	45	90	0.09	0.13	143	3.6	10	79
BZW03D110	99	110	121	12	2	79	65	125	0.09	0.13	157	3.3	10	86
BZW03D120	108	120	132	10	2	86	90	170	0.09	0.13	172	3	10	93
BZW03D130	117	130	143	10	2	93	100	190	0.09	0.13	187	2.7	10	106
BZW03D150	135	150	165	8	2	106	150	330	0.09	0.13	213	2.4	10	116
BZW03D160	144	160	176	8	2	116	180	350	0.09	0.13	229	2.2	10	126
BZW03D180	162	180	198	5	2	126	210	430	0.09	0.13	256	2	10	144
BZW03D200	180	200	220	5	2	144	250	500	0.09	0.13	284	1.8	10	158
BZW03D220	198	220	242	5	2	158	350	700	0.09	0.13	314	1.6	10	172
BZW03D240	216	240	264	5	2	172	450	900	0.09	0.13	344	1.5	10	194
BZW03D270	243	270	297	5	2	194	600	1200	0.09	0.13	388	1.3	10	215

Notes

- (1) Exp. falling pulse, $t_p = 500\text{ }\mu\text{s}$ down to 37 %
- (2) Stand-off reverse voltage = recommended supply voltage

BASIC CHARACTERISTICS ($T_{amb} = 25\text{ }^{\circ}\text{C}$, unless otherwise specified)

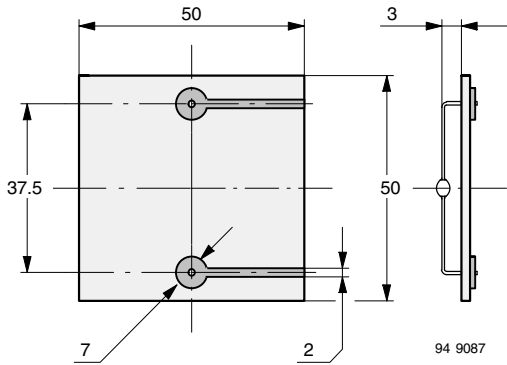

Fig. 1 - Epoxy Glass Hard Tissue, Board Thickness 1.5 mm, $R_{thJA} \leq 70\text{ K/W}$

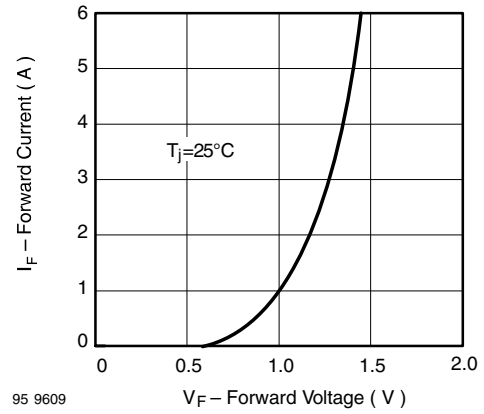

Fig. 3 - Forward Current vs. Forward Voltage

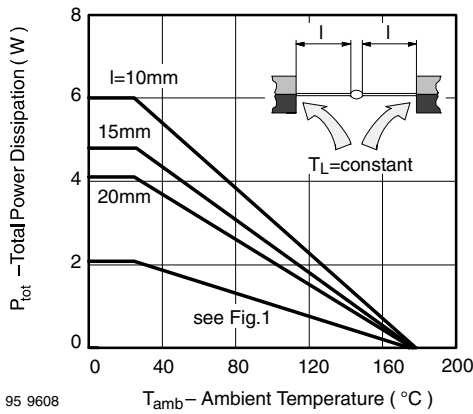

Fig. 2 - Total Power Dissipation vs. Ambient Temperature

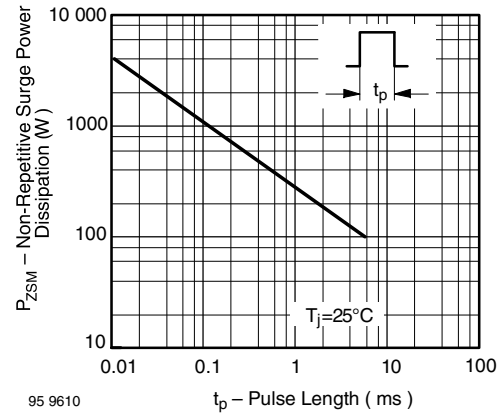
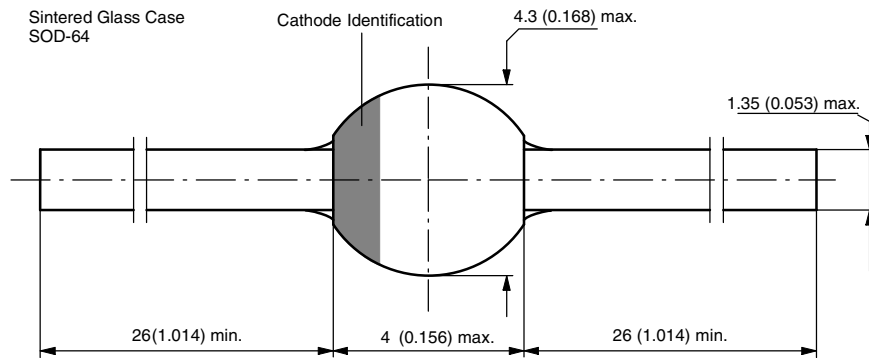

Fig. 4 - Non Repetitive Surge Power Dissipation vs. Pulse Length

PACKAGE DIMENSIONS in millimeters (inches): **SOD-64**



Document-No.: 6.563-5006.4-4
 Rev. 3 - Date: 09.February.2005
 94 9587



Disclaimer

ALL PRODUCT, PRODUCT SPECIFICATIONS AND DATA ARE SUBJECT TO CHANGE WITHOUT NOTICE TO IMPROVE RELIABILITY, FUNCTION OR DESIGN OR OTHERWISE.

Vishay Intertechnology, Inc., its affiliates, agents, and employees, and all persons acting on its or their behalf (collectively, "Vishay"), disclaim any and all liability for any errors, inaccuracies or incompleteness contained in any datasheet or in any other disclosure relating to any product.

Vishay makes no warranty, representation or guarantee regarding the suitability of the products for any particular purpose or the continuing production of any product. To the maximum extent permitted by applicable law, Vishay disclaims (i) any and all liability arising out of the application or use of any product, (ii) any and all liability, including without limitation special, consequential or incidental damages, and (iii) any and all implied warranties, including warranties of fitness for particular purpose, non-infringement and merchantability.

Statements regarding the suitability of products for certain types of applications are based on Vishay's knowledge of typical requirements that are often placed on Vishay products in generic applications. Such statements are not binding statements about the suitability of products for a particular application. It is the customer's responsibility to validate that a particular product with the properties described in the product specification is suitable for use in a particular application. Parameters provided in datasheets and / or specifications may vary in different applications and performance may vary over time. All operating parameters, including typical parameters, must be validated for each customer application by the customer's technical experts. Product specifications do not expand or otherwise modify Vishay's terms and conditions of purchase, including but not limited to the warranty expressed therein.

Except as expressly indicated in writing, Vishay products are not designed for use in medical, life-saving, or life-sustaining applications or for any other application in which the failure of the Vishay product could result in personal injury or death. Customers using or selling Vishay products not expressly indicated for use in such applications do so at their own risk. Please contact authorized Vishay personnel to obtain written terms and conditions regarding products designed for such applications.

No license, express or implied, by estoppel or otherwise, to any intellectual property rights is granted by this document or by any conduct of Vishay. Product names and markings noted herein may be trademarks of their respective owners.

Looking for pricing, stock, or lifecycle information?

Click below to explore more details on WIN SOURCE:

 [View BZW03C180-TAP on WIN SOURCE](#)

 [Vishay Information](#)

Optimize Your Supply Chain with WIN SOURCE Solutions

-  Global Sourcing Solution
-  Obsolete Management
-  Cost Control Management
-  Shortage Management
-  Alternative Solution
-  Excess Inventory Management