



# THE DATASHEET OF BTS6510B



# Smart Highside High Current Power Switch

## Reversave™

- Reverse battery protection by self turn on of power MOSFET

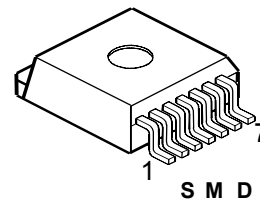
## Features

- Overload protection
- Current limitation
- Short circuit protection
- Overtemperature protection
- Overvoltage protection (including load dump)
- Clamp of negative voltage at output
- Fast deenergizing of inductive loads <sup>1)</sup>
- Low ohmic inverse current operation
- Diagnostic feedback with load current sense
- Open load detection via current sense
- Loss of  $V_{bb}$  protection<sup>2)</sup>
- Electrostatic discharge (ESD) protection

## Product Summary

Operating voltage	$V_{bb(on)}$	5.0 ... 34	V
On-state resistance	$R_{ON}$	6.0	mΩ
Noinal current	$I_{L(nom)}$	17	A
Load current (ISO)	$I_{L(ISO)}$	70	A
Short circuit current limitation	$I_{L(SC)}$	130	A
Current sense ratio	$I_L : I_{IS}$	14 000	

TO 220-7

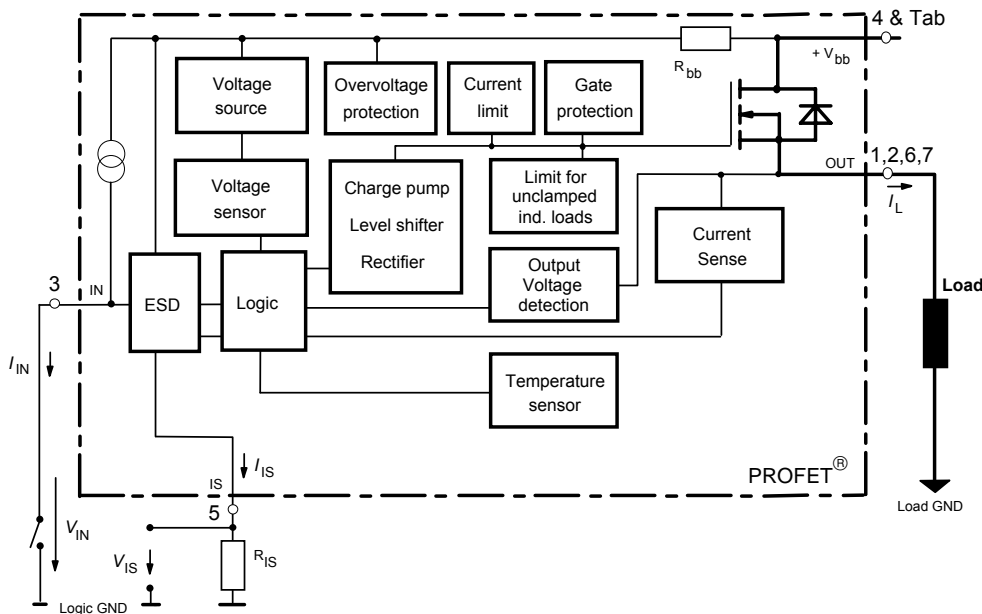


## Application

- Power switch with current sense diagnostic feedback for 12 V and 24 V DC grounded loads
- Most suitable for loads with high inrush current like lamps and motors; all types of resistive and inductive loads
- Replaces electromechanical relays, fuses and discrete circuits

## General Description

N channel vertical power FET with charge pump, current controlled input and diagnostic feedback with load current sense, integrated in Smart SIPMOS® chip on chip technology. Providing embedded protective functions.



<sup>1)</sup> With additional external diode.

<sup>2)</sup> Additional external diode required for energized inductive loads (see page 8).

Pin	Symbol		Function
1	OUT	O	Output to the load. The pins 1,2,6 and 7 must be shorted with each other especially in high current applications! <sup>3)</sup>
2	OUT	O	Output to the load. The pins 1,2,6 and 7 must be shorted with each other especially in high current applications! <sup>3)</sup>
3	IN	I	Input, activates the power switch in case of short to ground
4	V <sub>bb</sub>	+	Positive power supply voltage, the tab is electrically connected to this pin. In high current applications the tab should be used for the V <sub>bb</sub> connection instead of this pin <sup>4)</sup> .
5	IS	S	Diagnostic feedback providing a sense current proportional to the load current; zero current on failure (see Truth Table on page 6)
6	OUT	O	Output to the load. The pins 1,2,6 and 7 must be shorted with each other especially in high current applications! <sup>3)</sup>
7	OUT	O	Output to the load. The pins 1,2,6 and 7 must be shorted with each other especially in high current applications! <sup>3)</sup>

**Maximum Ratings** at  $T_j = 25\text{ °C}$  unless otherwise specified

Parameter	Symbol	Values	Unit
Supply voltage (overvoltage protection see page 4)	V <sub>bb</sub>	42	V
Supply voltage for short circuit protection, $T_{j,start} = -40 \dots +150\text{ °C}$ : (E <sub>AS</sub> limitation see diagram on page 9)	V <sub>bb</sub>	34	V
Load current (short circuit current, see page 5)	I <sub>L</sub>	self-limited	A
Load dump protection V <sub>LoadDump</sub> = V <sub>A</sub> + V <sub>S</sub> , V <sub>A</sub> = 13.5 V R <sub>I</sub> <sup>5)</sup> = 2 Ω, R <sub>L</sub> = 0.54 Ω, t <sub>d</sub> = 200 ms, IN, IS = open or grounded	V <sub>Load dump</sub> <sup>6)</sup>	75	V
Operating temperature range	T <sub>j</sub>	-40 ... +150	°C
Storage temperature range	T <sub>stg</sub>	-55 ... +150	
Power dissipation (DC), T <sub>C</sub> ≤ 25 °C	P <sub>tot</sub>	170	W
Inductive load switch-off energy dissipation, single pulse V <sub>bb</sub> = 12 V, T <sub>j,start</sub> = 150 °C, T <sub>C</sub> = 150 °C const., I <sub>L</sub> = 20 A, Z <sub>L</sub> = 7.5 mH, 0 Ω, (see diagrams on page 9)	E <sub>AS</sub>	1.5	J
Electrostatic discharge capability (ESD) Human Body Model acc. MIL-STD883D, method 3015.7 and ESD assn. std. S5.1-1993, C = 100 pF, R = 1.5 kΩ	V <sub>ESD</sub>	4	kV
Current through input pin (DC)	I <sub>IN</sub>	+15, -250	mA
Current through current sense status pin (DC) see internal circuit diagrams on page 7	I <sub>IS</sub>	+15, -250	

<sup>3)</sup> Not shorting all outputs will considerably increase the on-state resistance, reduce the peak current capability and decrease the current sense accuracy

<sup>4)</sup> Otherwise add about 0.3 mΩ to the R<sub>ON</sub> if the pin is used instead of the tab.

<sup>5)</sup> R<sub>I</sub> = internal resistance of the load dump test pulse generator.

<sup>6)</sup> V<sub>Load dump</sub> is setup without the DUT connected to the generator per ISO 7637-1 and DIN 40839.

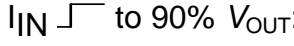
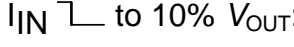
**Thermal Characteristics**

Parameter and Conditions	Symbol	Values			Unit
		min	typ	max	
Thermal resistance chip - case:	$R_{thJC}^{7)}$	--	--	0.75	K/W
junction - ambient (free air):	$R_{thJA}$	--	60	--	
SMD version, device on PCB <sup>8)</sup> :			33		

**Electrical Characteristics**

Parameter and Conditions	Symbol	Values			Unit
		min	typ	max	
at $T_j = -40 \dots +150^\circ\text{C}$ , $V_{bb} = 12\text{ V}$ unless otherwise specified					

**Load Switching Capabilities and Characteristics**

On-state resistance (Tab to pins 1,2,6,7) $V_{IN} = 0$ , $I_L = 20\text{ A}$	$T_j = 25^\circ\text{C}$ : $T_j = 150^\circ\text{C}$ :	$R_{ON}$	--	4.4	6.0	m $\Omega$
$V_{IN} = 0$ , $I_L = 90\text{ A}$	$T_j = 150^\circ\text{C}$ :			--	10.7	
$V_{bb} = 6\text{ V}^{9)}$ , $V_{IN} = 0$ , $I_L = 20\text{ A}$	$T_j = 150^\circ\text{C}$ :	--	10	17		
Nominal load current <sup>10)</sup> , (Tab to pins 1,2,6,7) ISO Proposal: $V_{ON} = 0.5\text{ V}$ , $T_C = 85^\circ\text{C}$ , $T_j \leq 150^\circ\text{C}$ <sup>11)</sup> SMD <sup>8)</sup> : $T_A = 85^\circ\text{C}$ , $T_j \leq 150^\circ\text{C}$ $V_{ON} \leq 0.5\text{ V}$		$I_{L(ISO)}$	55	70	--	A
		$I_{L(NOM)}$	13.6	17	--	
Maximum load current in resistive range (Tab to pins 1,2,6,7) $V_{ON} = 1.8\text{ V}$ , $T_C = 25^\circ\text{C}$ : see diagram on page 12 $V_{ON} = 1.8\text{ V}$ , $T_C = 150^\circ\text{C}$ :		$I_{L(Max)}$	250	--	--	A
Turn-on time <sup>12)</sup>	$I_{IN}$  to 90% $V_{OUT}$ :	$t_{on}$	150	230	470	$\mu\text{s}$
Turn-off time	$I_{IN}$  to 10% $V_{OUT}$ :	$t_{off}$	80	130	200	
$R_L = 1\ \Omega$ , $T_j = -40\dots+150^\circ\text{C}$						
Slew rate on <sup>12)</sup> (10 to 30% $V_{OUT}$ ) $R_L = 1\ \Omega$ , $T_j = 25^\circ\text{C}$		$dV/dt_{on}$	0.1	0.25	0.6	V/ $\mu\text{s}$
Slew rate off <sup>12)</sup> (70 to 40% $V_{OUT}$ ) $R_L = 1\ \Omega$ , $T_j = 25^\circ\text{C}$		$-dV/dt_{off}$	0.15	0.35	0.6	V/ $\mu\text{s}$

<sup>7)</sup> Thermal resistance  $R_{thCH}$  case to heatsink (about 0.5 ... 0.9 K/W with silicone paste) not included!

<sup>8)</sup> Device on 50mm\*50mm\*1.5mm epoxy PCB FR4 with 6cm<sup>2</sup> (one layer, 70 $\mu\text{m}$  thick) copper area for  $V_{bb}$  connection. PCB is vertical without blown air.

<sup>9)</sup> Decrease of  $V_{bb}$  below 10 V causes slowly a dynamic increase of  $R_{ON}$  to a higher value of  $R_{ON(Static)}$ . As long as  $V_{bIN} > V_{bIN(u) max}$ ,  $R_{ON}$  increase is less than 10 % per second for  $T_j < 85^\circ\text{C}$ .

<sup>10)</sup> not subject to production test, specified by design

<sup>11)</sup>  $T_j$  is about 105 $^\circ\text{C}$  under these conditions.

<sup>12)</sup> See timing diagram on page 13.

Parameter and Conditions at $T_j = -40 \dots +150^\circ\text{C}$ , $V_{bb} = 12\text{V}$ unless otherwise specified	Symbol	Values			Unit
		min	typ	max	

**Inverse Load Current Operation**

On-state resistance (Pins 1,2,6,7 to pin 4) $V_{bIN} = 12\text{V}$ , $I_L = -20\text{A}$ see page 9 $T_j = 25^\circ\text{C}$ : $T_j = 150^\circ\text{C}$ :	$R_{ON(inv)}$	--	4.4 7.9	6.0 10.5	$\text{m}\Omega$
Nominal inverse load current (Pins 1,2,6,7 to Tab) $V_{ON} = -0.5\text{V}$ , $T_C = 85^\circ\text{C}^{11)}$	$I_{L(inv)}$	55	70	--	A
Drain-source diode voltage ( $V_{out} > V_{bb}$ ) $I_L = -20\text{A}$ , $I_{IN} = 0$ , $T_j = +150^\circ\text{C}$	$-V_{ON}$	--	0.6	--	V

**Operating Parameters**

Operating voltage ( $V_{IN} = 0$ ) <sup>9, 13)</sup>	$V_{bb(on)}$	5.0	--	34	V	
Undervoltage shutdown <sup>14)</sup>	$V_{bIN(u)}$	1.5	3.0	4.5	V	
Undervoltage start of charge pump see diagram page 14	$V_{bIN(ucp)}$	3.0	4.5	6.0	V	
Overvoltage protection <sup>15)</sup> $I_{bb} = 15\text{mA}$	$V_{bIN(z)}$	$T_j = -40^\circ\text{C}$ : $T_j = 25\dots+150^\circ\text{C}$ :	60 62	-- 66	-- --	V
Standby current $I_{IN} = 0$	$I_{bb(off)}$	$T_j = -40\dots+25^\circ\text{C}$ : $T_j = 150^\circ\text{C}$ :	-- --	15 25	25 50	$\mu\text{A}$

<sup>13)</sup> If the device is turned on before a  $V_{bb}$ -decrease, the operating voltage range is extended down to  $V_{bIN(u)}$ . For all voltages 0 ... 34 V the device is fully protected against overtemperature and short circuit.

<sup>14)</sup>  $V_{bIN} = V_{bb} - V_{IN}$  see diagram on page 7. When  $V_{bIN}$  increases from less than  $V_{bIN(u)}$  up to  $V_{bIN(ucp)} = 5\text{V}$  (typ.) the charge pump is not active and  $V_{OUT} \approx V_{bb} - 3\text{V}$ .

<sup>15)</sup> See also  $V_{ON(CL)}$  in circuit diagram on page 8.

Parameter and Conditions at $T_j = -40 \dots +150^\circ\text{C}$ , $V_{bb} = 12\text{V}$ unless otherwise specified	Symbol	Values			Unit
		min	typ	max	

**Protection Functions<sup>16)</sup>**

Short circuit current limit (Tab to pins 1,2,6,7) <sup>17)</sup> $V_{ON} = 6\text{V}$	$T_C = -40^\circ\text{C}$ : $I_{L(SC)}$	--	110	--	A
	$T_C = 25^\circ\text{C}$ : $I_{L(SC)}$	45	130	180	
	$T_C = +150^\circ\text{C}$ : $I_{L(SC)}$	--	115	--	
Output clamp <sup>18)</sup> (inductive load switch off) see diagram Ind. and overvolt. output clamp page 7	$I_L = 40\text{mA}$ : $-V_{OUT(CL)}$	14	17	20	V
Output clamp (inductive load switch off) at $V_{OUT} = V_{bb} - V_{ON(CL)}$ (e.g. overvoltage), $I_L = 40\text{mA}$	$V_{ON(CL)}$	39	42	47	V
Thermal overload trip temperature	$T_{jt}$	150	--	--	$^\circ\text{C}$
Thermal hysteresis	$\Delta T_{jt}$	--	10	--	K

**Reverse Battery**

Reverse battery voltage <sup>19)</sup>	$-V_{bb}$	--	--	32	V
On-state resistance (Pins 1,2,6,7 to pin 4) $V_{bb} = -12\text{V}$ , $V_{IN} = 0$ , $I_L = -20\text{A}$ , $R_{IS} = 1\text{k}\Omega$	$T_j = 25^\circ\text{C}$ : $R_{ON(rev)}$ $T_j = 150^\circ\text{C}$ :	--	5.4 8.9	7.0 12.3	$\text{m}\Omega$
Integrated resistor in $V_{bb}$ line	$R_{bb}$	--	120	--	$\Omega$

**Diagnostic Characteristics**

Current sense ratio, static on-condition, $k_{ILIS} = I_L : I_{IS}$ , $V_{ON} < 1.5\text{V}^{20)}$ , $V_{IS} < V_{OUT} - 5\text{V}$ , $V_{bIN} > 4.0\text{V}$ see diagram on page 11	$I_L = 90\text{A}$ , $T_j = -40^\circ\text{C}$ :	$k_{ILIS}$	12 400	14 200	16 000
	$T_j = 25^\circ\text{C}$ :		12 000	13 700	15 400
	$T_j = 150^\circ\text{C}$ :		11 400	12 800	14 200
	$I_L = 20\text{A}$ , $T_j = -40^\circ\text{C}$ :		12 200	14 800	17 400
	$T_j = 25^\circ\text{C}$ :		12 000	14 100	16 200
	$T_j = 150^\circ\text{C}$ :		11 500	13 200	15 000
	$I_L = 10\text{A}$ , $T_j = -40^\circ\text{C}$ :		11 100	15 300	19 500
	$T_j = 25^\circ\text{C}$ :		11 500	14 500	17 500
	$T_j = 150^\circ\text{C}$ :		11 400	13 300	15 200
	$I_L = 4\text{A}$ , $T_j = -40^\circ\text{C}$ :		10 000	17 600	28 500
	$T_j = 25^\circ\text{C}$ :		11 000	15 600	22 000
	$T_j = 150^\circ\text{C}$ :		10 600	13 800	18 000
	$I_{IS} = 0$ by $I_{IN} = 0$ (e.g. during deenergizing of inductive loads):				

<sup>16)</sup> Integrated protection functions are designed to prevent IC destruction under fault conditions described in the data sheet. Fault conditions are considered as "outside" normal operating range. Protection functions are not designed for continuous repetitive operation.

<sup>17)</sup> Short circuit is a failure mode. The device is not designed to operate continuously into a short circuit. The lifetime will be reduced under such conditions.

<sup>18)</sup> This output clamp can be "switched off" by using an additional diode at the IS-Pin (see page 7). If the diode is used,  $V_{OUT}$  is clamped to  $V_{bb} - V_{ON(CL)}$  at inductive load switch off.

<sup>19)</sup> The reverse load current through the intrinsic drain-source diode has to be limited by the connected load (as it is done with all polarity symmetric loads). Note that under off-conditions ( $I_{IN} = I_{IS} = 0$ ) the power transistor is not activated. This results in raised power dissipation due to the higher voltage drop across the intrinsic drain-source diode. The temperature protection is not active during reverse current operation! Increasing reverse battery voltage capability is simply possible as described on page 8.

<sup>20)</sup> If  $V_{ON}$  is higher, the sense current is no longer proportional to the load current due to sense current saturation, see  $I_{IS,lim}$ .

Parameter and Conditions at $T_j = -40 \dots +150^\circ\text{C}$ , $V_{bb} = 12\text{V}$ unless otherwise specified	Symbol	Values			Unit
		min	typ	max	
Sense current saturation	$I_{S,lim}$	6.5	--	--	mA
Current sense leakage current $I_{IN} = 0$ : $V_{IN} = 0, I_L \leq 0$ :	$I_{S(LL)}$	--	--	0.5	$\mu\text{A}$
	$I_{S(LH)}$	--	2	--	
Current sense overvoltage protection $I_{bb} = 15\text{mA}$ $T_j = -40^\circ\text{C}$ : $T_j = 25\dots+150^\circ\text{C}$ :	$V_{bIS(Z)}$	60	--	--	V
		62	66	--	
Current sense settling time <sup>21)</sup>	$t_{s(IS)}$	--	--	500	$\mu\text{s}$

### Input

Input and operating current (see diagram page 12) IN grounded ( $V_{IN} = 0$ )	$I_{IN(on)}$	--	0.8	1.5	mA
Input current for turn-off <sup>22)</sup>	$I_{IN(off)}$	--	--	80	$\mu\text{A}$

### Truth Table

	Input current level	Output level	Current Sense $I_S$	Remark
Normal operation	L H	L H	0 nominal	$=I_L / k_{IIS}$ , up to $I_S = I_{S,lim}$
Very high load current	H	H	$I_{S,lim}$	up to $V_{ON} = V_{ON(Fold\ back)}$ $I_S$ no longer proportional to $I_L$
Current-limitation	H	H	0	$V_{ON} > V_{ON(Fold\ back)}$
Short circuit to GND	L	L	0	
	H	L	0	
Over-temperature	L	L	0	
	H	L	0	
Short circuit to $V_{bb}$	L	H	0	
	H	H	<nominal <sup>23)</sup>	
Open load	L	Z <sup>24)</sup>	0	
	H	H	0	
Negative output voltage clamp	L	L	0	
Inverse load current	L	H	0	
	H	H	0	

L = "Low" Level

H = "High" Level

Overtemperature reset by cooling:  $T_j < T_{jt}$  (see diagram on page 14)

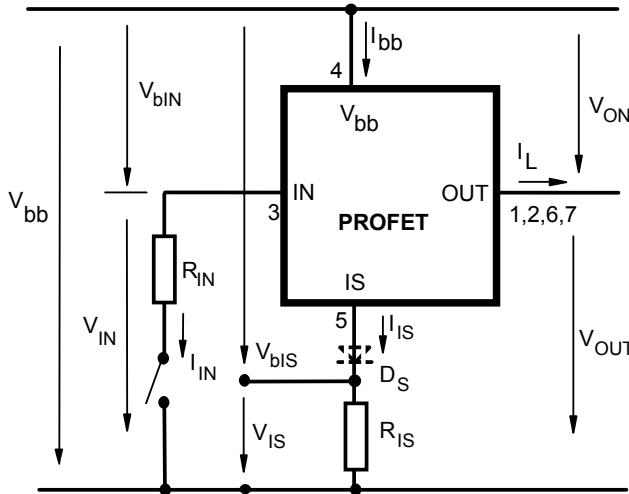
<sup>21)</sup> not subject to production test, specified by design

<sup>22)</sup> We recommend the resistance between IN and GND to be less than 0.5 k $\Omega$  for turn-on and more than 500k $\Omega$  for turn-off. Consider that when the device is switched off ( $I_{IN} = 0$ ) the voltage between IN and GND reaches almost  $V_{bb}$ .

<sup>23)</sup> Low ohmic short to  $V_{bb}$  may reduce the output current  $I_L$  and can thus be detected via the sense current  $I_S$ .

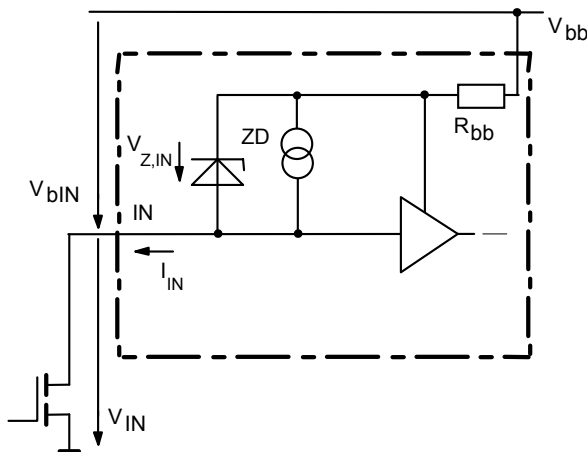
<sup>24)</sup> Power Transistor "OFF", potential defined by external impedance.

**Terms**



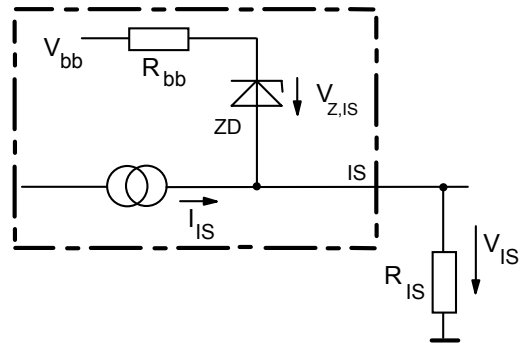
Two or more devices can easily be connected in parallel to increase load current capability.

**Input circuit (ESD protection)**



When the device is switched off ( $I_{IN} = 0$ ) the voltage between IN and GND reaches almost  $V_{bb}$ . Use a mechanical switch, a bipolar or MOS transistor with appropriate breakdown voltage as driver.  $V_{Z,IN} = 66\text{ V (typ.)}$ .

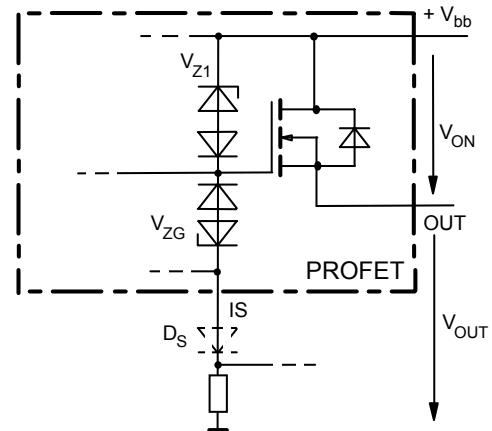
**Current sense status output**



$V_{Z,IS} = 66\text{ V (typ.)}$ ,  $R_{IS} = 1\text{ k}\Omega$  nominal (or  $1\text{ k}\Omega / n$ , if  $n$  devices are connected in parallel).  $I_S = I_L / K_{iis}$  can be driven only by the internal circuit as long as  $V_{out} - V_{IS} > 5\text{ V}$ . If you want measure load currents up to  $I_{L(M)}$ ,  $R_{IS}$  should be less than  $\frac{V_{bb} - 5\text{ V}}{I_{L(M)} / K_{iis}}$ .

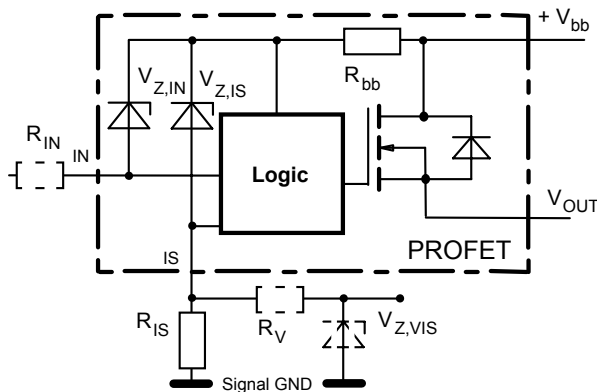
Note: For large values of  $R_{IS}$  the voltage  $V_{IS}$  can reach almost  $V_{bb}$ . See also overvoltage protection. If you don't use the current sense output in your application, you can leave it open.

**Inductive and overvoltage output clamp**



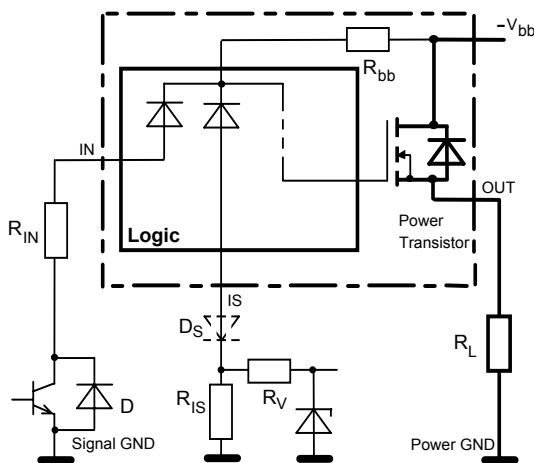
$V_{ON}$  is clamped to  $V_{ON(CL)} = 42\text{ V typ.}$  At inductive load switch-off without  $D_S$ ,  $V_{OUT}$  is clamped to  $V_{OUT(CL)} = -19\text{ V typ.}$  via  $V_{ZG}$ . With  $D_S$ ,  $V_{OUT}$  is clamped to  $V_{bb} - V_{ON(CL)}$  via  $V_{Z1}$ . Using  $D_S$  gives faster deenergizing of the inductive load, but higher peak power dissipation in the PROFET. In case of a floating ground with a potential higher than 19V referring to the OUT – potential the device will switch on, if diode  $D_S$  is not used.

### Overvoltage protection of logic part



$R_{bb} = 120\Omega$  typ.,  $V_{Z,IN} = V_{Z,IS} = 66V$  typ.,  $R_{IS} = 1k\Omega$  nominal. Note that when overvoltage exceeds 71 V typ. a voltage above 5V can occur between IS and GND, if  $R_V$ ,  $V_{Z,VIS}$  are not used.

### Reverse battery protection



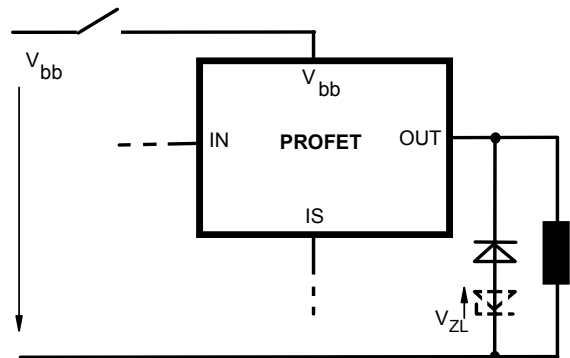
$R_V \geq 1k\Omega$ ,  $R_{IS} = 1k\Omega$  nominal. Add  $R_{IN}$  for reverse battery protection in applications with  $V_{bb}$  above 16 V<sup>19)</sup>; recommended value:  $\frac{1}{R_{IN}} + \frac{1}{R_{IS}} + \frac{1}{R_V} = \frac{0.1A}{|V_{bb}| - 12V}$  if  $D_S$  is not used (or  $\frac{1}{R_{IN}} = \frac{0.1A}{|V_{bb}| - 12V}$  if  $D_S$  is used).

To minimize power dissipation at reverse battery operation, the summarized current into the IN and IS pin should be about 120mA. The current can be provided by using a small signal diode D in parallel to the input switch, by using a MOSFET input switch or by proper adjusting the current through  $R_{IS}$  and  $R_V$ .

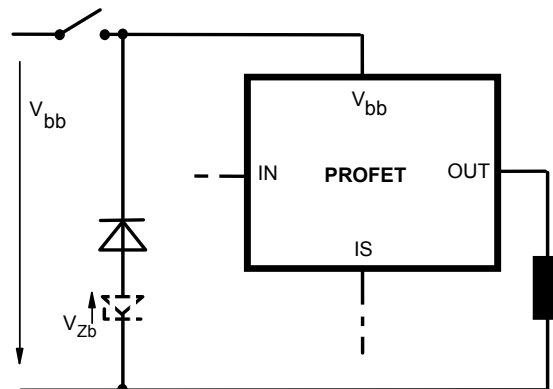
### V<sub>bb</sub> disconnect with energized inductive load

Provide a current path with load current capability by using a diode, a Z-diode, or a varistor. ( $V_{ZL} < 72V$  or  $V_{Zb} < 30V$  if  $R_{IN}=0$ ). For higher clamp voltages currents at IN and IS have to be limited to 250 mA.

Version a:

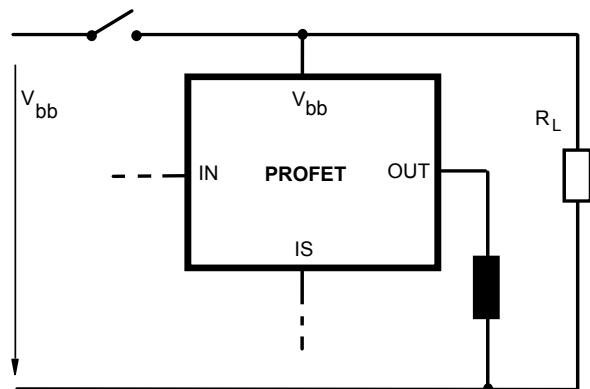


Version b:

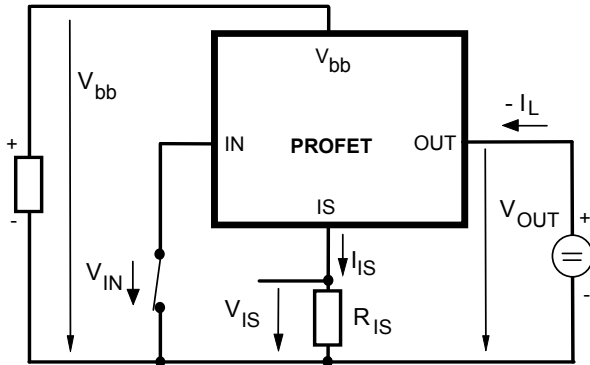


Note that there is no reverse battery protection when using a diode without additional Z-diode  $V_{ZL}$ ,  $V_{Zb}$ .

Version c: Sometimes a necessary voltage clamp is given by non inductive loads  $R_L$  connected to the same switch and eliminates the need of clamping circuit:



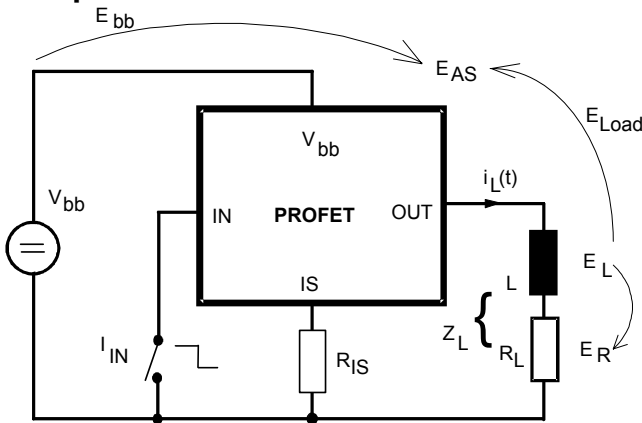
### Inverse load current operation



The device is specified for inverse load current operation ( $V_{OUT} > V_{bb} > 0V$ ). The current sense feature is not available during this kind of operation ( $I_{IS} = 0$ ). With  $I_{IN} = 0$  (e.g. input open) only the intrinsic drain source diode is conducting resulting in considerably increased power dissipation. If the device is switched on ( $V_{IN} = 0$ ), this power dissipation is decreased to the much lower value  $R_{ON(INV)} \cdot I^2$  (specifications see page 4).

Note: Temperature protection during inverse load current operation is not possible!

### Inductive load switch-off energy dissipation



Energy stored in load inductance:

$$E_L = 1/2 \cdot L \cdot I_L^2$$

While demagnetizing load inductance, the energy dissipated in PROFET is

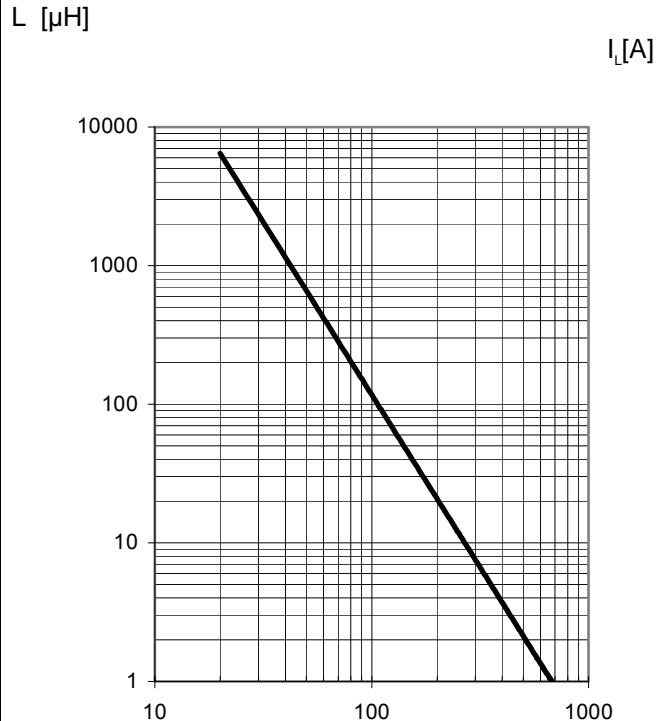
$$E_{AS} = E_{bb} + E_L - E_R = V_{ON(CL)} \cdot \int i_L(t) dt,$$

with an approximate solution for  $R_L > 0 \Omega$ :

$$E_{AS} = \frac{I_L \cdot L}{2 \cdot R_L} (V_{bb} + |V_{OUT(CL)}|) \ln \left( 1 + \frac{I_L \cdot R_L}{|V_{OUT(CL)}|} \right)$$

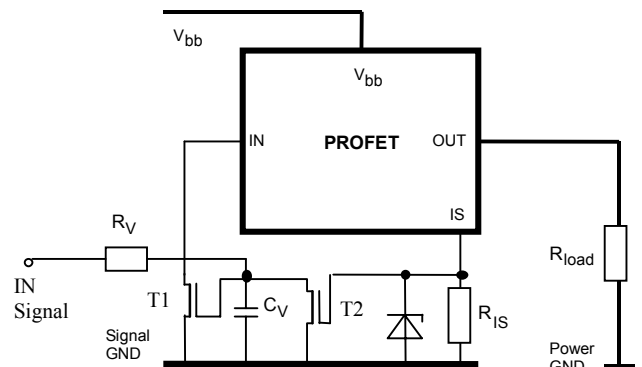
### Maximum allowable load inductance for a single switch off

$$L = f(I_L); T_{j,start} = 150^\circ C, V_{bb} = 12V, R_L = 0 \Omega$$



### Externally adjustable current limit

If the device is conducting, the sense current can be used to reduce the short circuit current and allow higher lead inductance (see diagram above). The device will be turned off, if the threshold voltage of T2 is reached by  $I_s \cdot R_{IS}$ . After a delay time defined by  $R_V \cdot C_V$  T1 will be reset. The device is turned on again, the short circuit current is defined by  $I_{L(SC)}$ .



**Options Overview**

Type	BTS	6510P	550P 650P	555
Overtemperature protection with hysteresis $T_j > 150\text{ °C}$ , latch function <sup>25)</sup>		X	X	X
$T_j > 150\text{ °C}$ , with auto-restart on cooling		X	X	X
Short circuit to GND protection with overtemperature shutdown switches off when $V_{ON} > 6\text{ V typ.}$ (when first turned on after approx. 180 $\mu\text{s}$ )		X	X	X
Overvoltage shutdown		-	-	-
Output negative voltage transient limit to $V_{bb} - V_{ON(CL)}$ to $V_{OUT} = -19\text{ V typ}$		X X <sup>26)</sup>	X X <sup>26)</sup>	X X <sup>26)</sup>

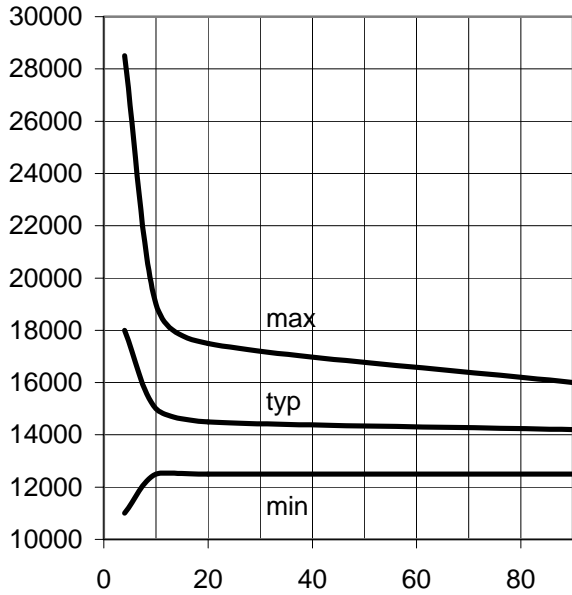
<sup>25)</sup> Latch except when  $V_{bb} - V_{OUT} < V_{ON(SC)}$  after shutdown. In most cases  $V_{OUT} = 0\text{ V}$  after shutdown ( $V_{OUT} \neq 0\text{ V}$  only if forced externally). So the device remains latched unless  $V_{bb} < V_{ON(SC)}$  (see page 5). No latch between turn on and  $t_{d(SC)}$ .

<sup>26)</sup> Can be "switched off" by using a diode  $D_S$  (see page 8) or leaving open the current sense output.

### Characteristics

**Current sense versus load current:**

$I_{IS} = f(I_L), T_J = -40 \dots +150 \text{ }^\circ\text{C}$



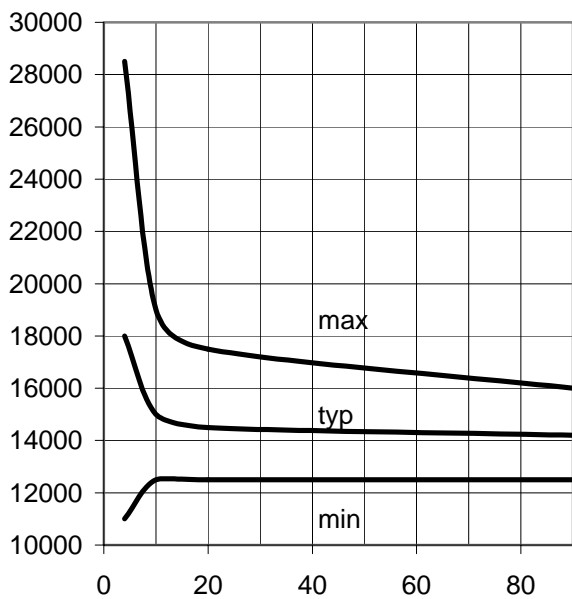
$I_{IS}$  [mA]

$I_L$  [A]

**Current sense ratio:**

$K_{ILIS} = f(I_L), T_J = -40^\circ\text{C}$

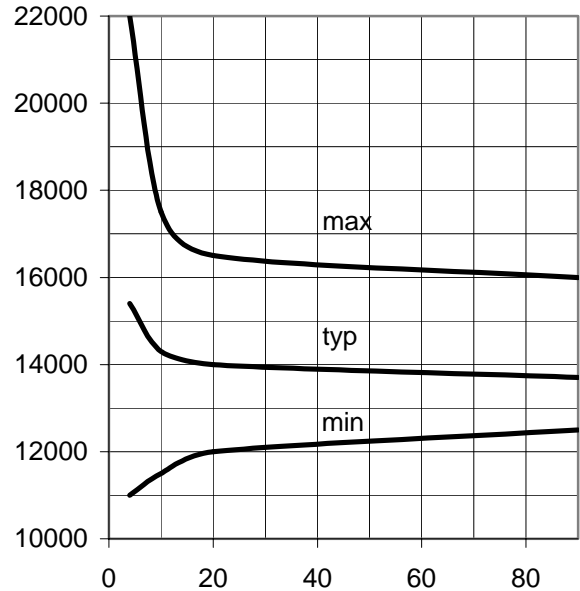
$k_{ILIS}$



$I_L$  [A]

**Current sense ratio:**

$I_{IS} = f(I_L), T_J = 25 \text{ }^\circ\text{C}$



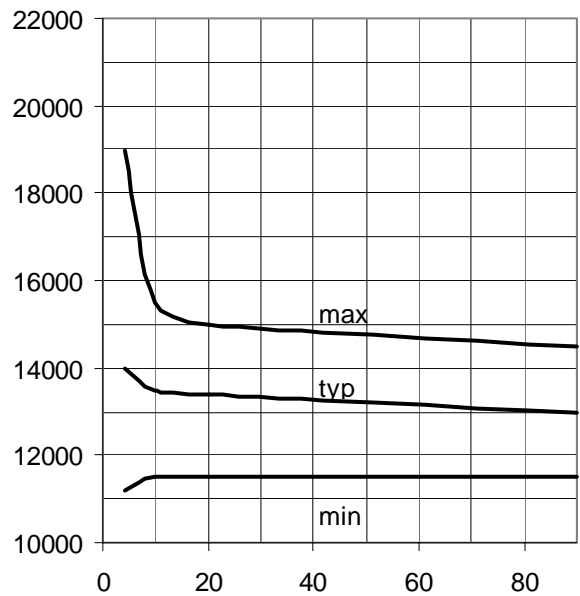
$k_{ILIS}$

$I_L$  [A]

**Current sense ratio:**

$K_{ILIS} = f(I_L), T_J = 150^\circ\text{C}$

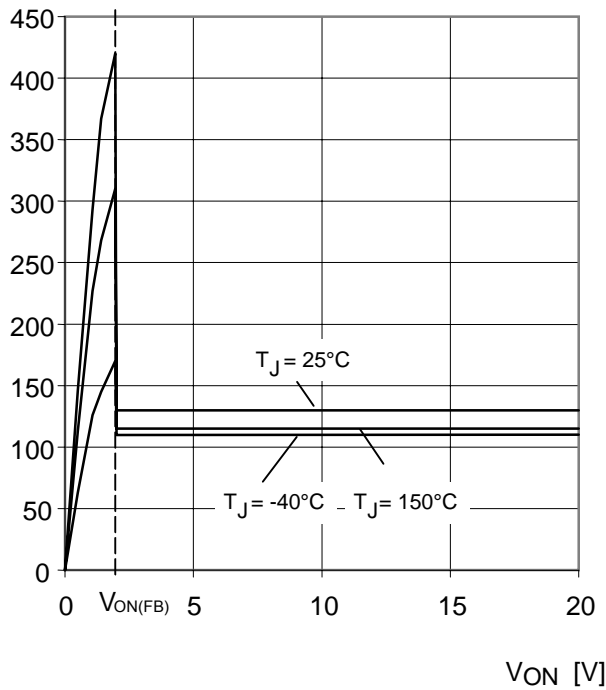
$k_{ILIS}$



$I_L$  [A]

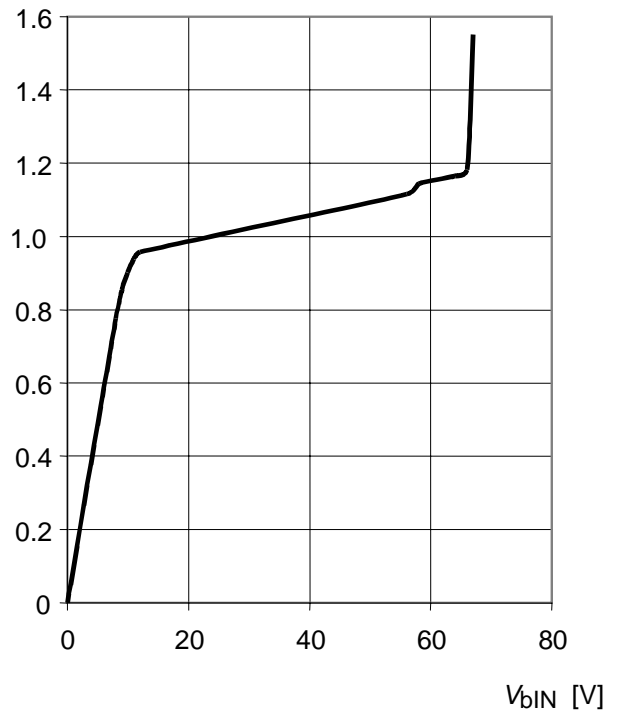
**Typ. current limitation characteristic**  
 $I_L = f(V_{ON}, T_j)$

$I_L$  [A]



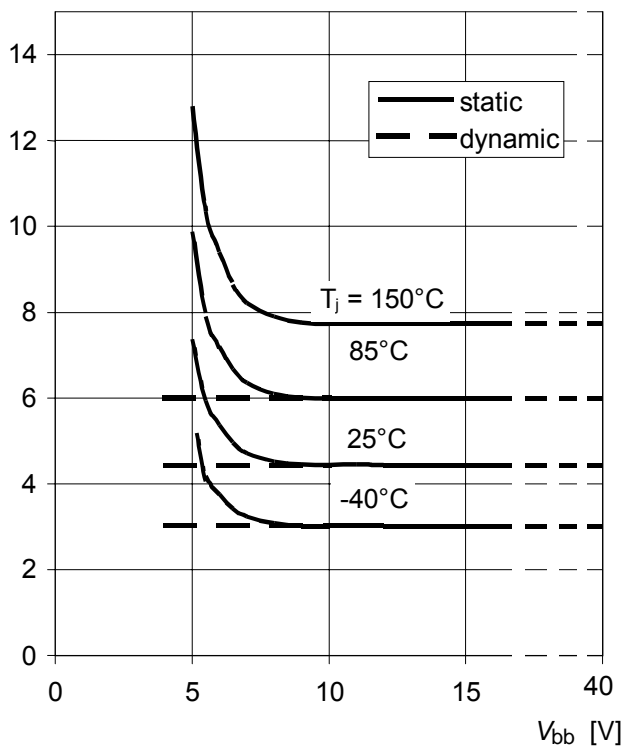
**Typ. input current**

$I_{IN} = f(V_{bIN}), V_{bIN} = V_{bb} - V_{IN}$   
 $I_{IN}$  [mA]



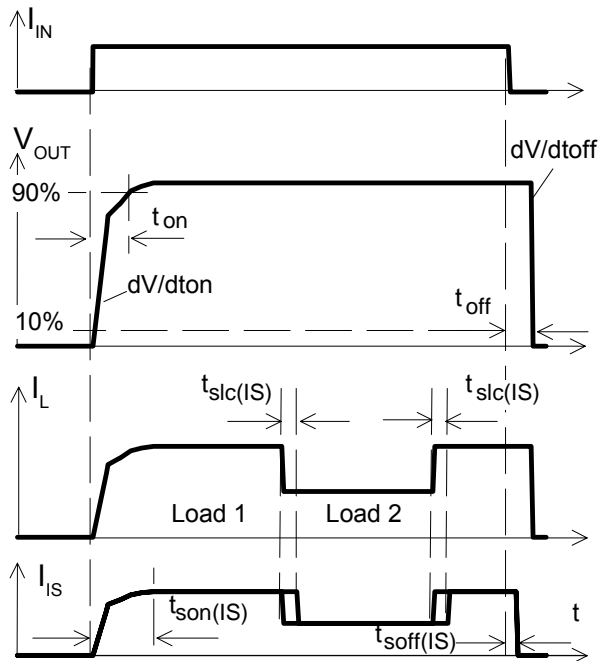
**Typ. on-state resistance**  
 $R_{ON} = f(V_{bb}, T_j); I_L = 20\text{ A}; V_{IN} = 0$

$R_{ON}$  [mOhm]



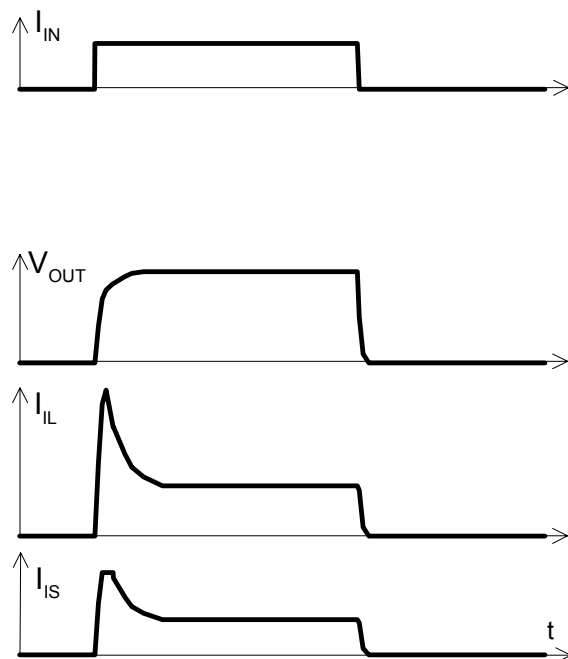
## Timing diagrams

**Figure 1a:** Switching a resistive load, change of load current in on-condition:



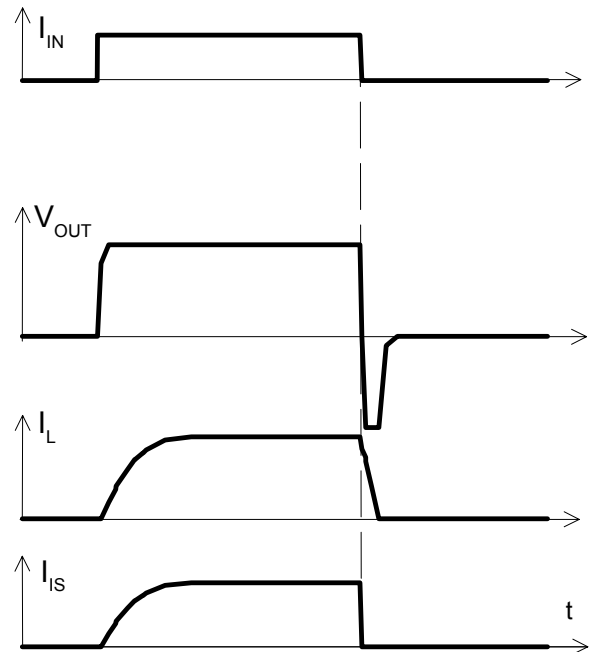
The sense signal is not valid during a settling time after turn-on/off and after change of load current.

**Figure 2b:** Switching motors and lamps:



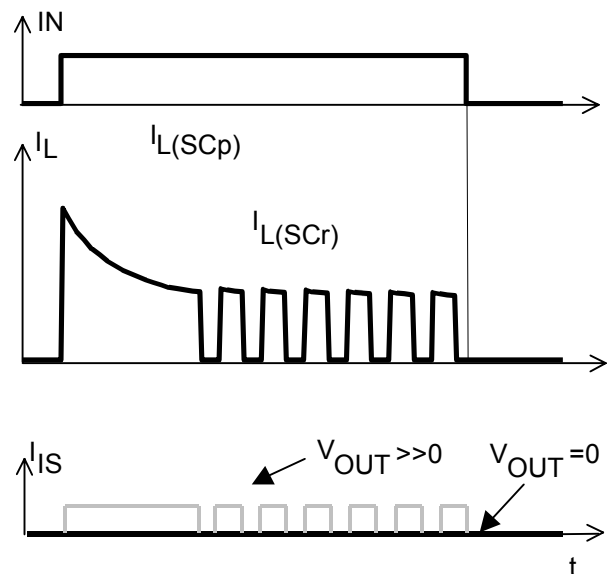
Sense current saturation can occur at very high inrush currents (see  $I_{IS,lim}$  on page Fehler! Textmarke nicht definiert.).

**Figure 2c:** Switching an inductive load:

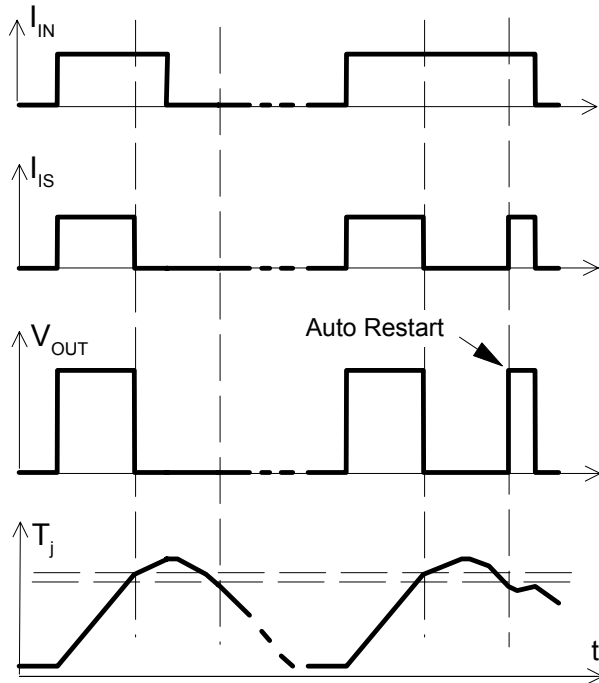


**Figure 3d:** Short circuit:

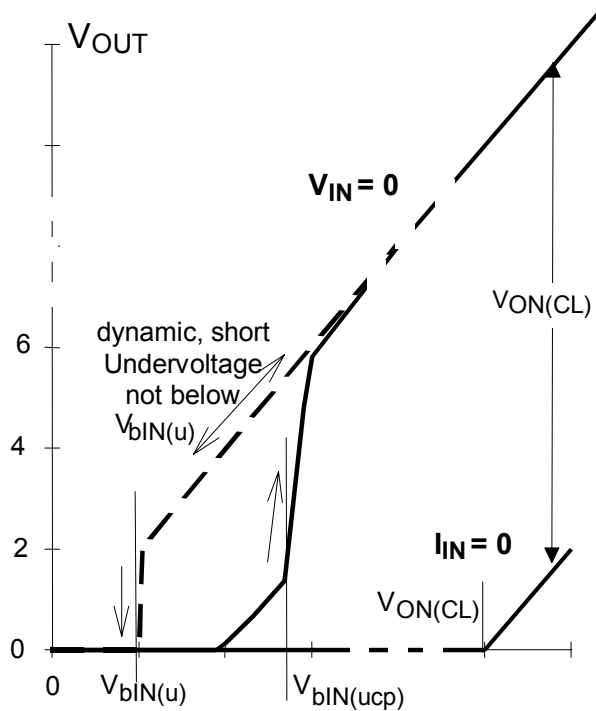
shut down by overtemperature detection with auto restart on cooling



**Figure 4e:** Overtemperature Reset if  $T_j < T_{jt}$



**Figure 6f:** Undervoltage restart of charge pump, overvoltage clamp



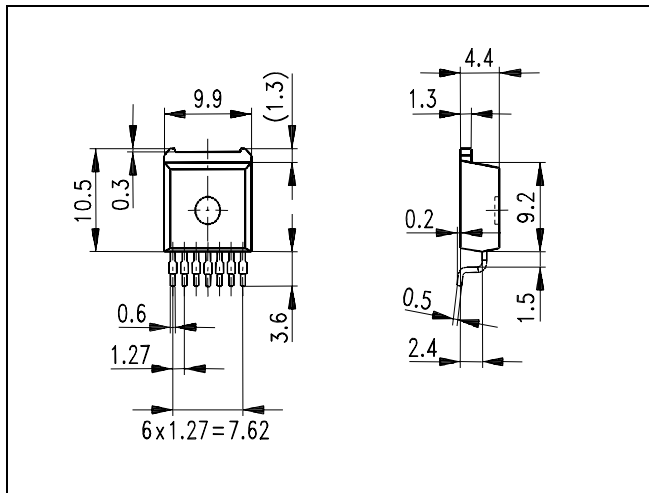
## Package and Ordering Code

All dimensions in mm

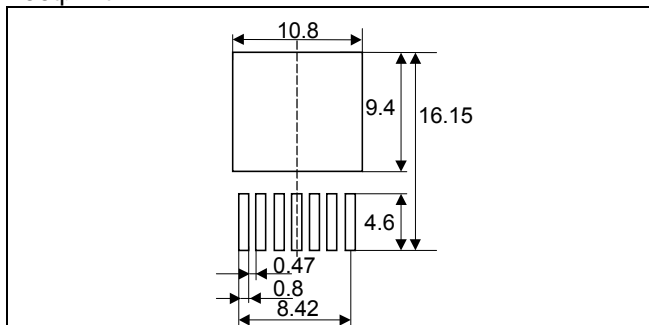
### SMD TO 220-7,

Ordering code

BTS 6510 B	T&R:	Q67060-S6311
------------	------	--------------



Footprint:



Published by  
**Infineon Technologies AG,**  
**St.-Martin-Strasse 53,**  
**D-81669 München**  
 © Infineon Technologies AG 2001  
**All Rights Reserved.**

#### Attention please!

The information herein is given to describe certain components and shall not be considered as a guarantee of characteristics.

Terms of delivery and rights to technical change reserved.

We hereby disclaim any and all warranties, including but not limited to warranties of non-infringement, regarding circuits, descriptions and charts stated herein.

Infineon Technologies is an approved CECC manufacturer.

#### Information

For further information on technology, delivery terms and conditions and prices please contact your nearest Infineon Technologies Office in Germany or our Infineon Technologies Representatives worldwide (see address list).



#### Warnings

Due to technical requirements components may contain dangerous substances. For information on the types in question please contact your nearest Infineon Technologies Office.

Infineon Technologies Components may only be used in life-support devices or systems with the express written approval of Infineon Technologies, if a failure of such components can reasonably be expected to cause the failure of that life-support device or system, or to affect the safety or effectiveness of that device or system. Life support devices or systems are intended to be implanted in the human body, or to support and/or maintain and sustain and/or protect human life. If they fail, it is reasonable to assume that the health of the user or other persons may be endangered.

## Looking for pricing, stock, or lifecycle information?

Click below to explore more details on WIN SOURCE:

-  [View BTS6510B on WIN SOURCE](#)
-  [Infineon Technologies Information](#)

## Optimize Your Supply Chain with WIN SOURCE Solutions

-  Global Sourcing Solution
-  Obsolete Management
-  Cost Control Management
-  Shortage Management
-  Alternative Solution
-  Excess Inventory Management