



**THE DATASHEET OF  
NCP4371AACDR2G**



# NCP4371

## Qualcomm Quick Charge™ 3.0 HVDCP Controller

NCP4371 is a USB secondary side fast-charging controller, supporting Qualcomm Quick Charge 3.0 (QC 3.0) High Voltage Dedicated Charging Port (HVDCP) Class A and Class B specification. NCP4371 allows for selection of the output voltage of an AC-DC USB adapter based on commands from the Portable Device (PD) being powered. Selecting a higher charging voltage will reduce the charging current for a given power level resulting in reduced IR drops and increased system efficiency. Another advantage of QC3.0 is a decreased battery charging time and a reduced PD system cost thanks to the ability to select an optimum charging voltage. This eliminates the need for costly DC-DC converters within the PD. The USB-bus voltage can be controlled in discreet steps from 3.6 V up to 20 V. The output current is limited not to exceed maximum allowable power level.

The NCP4371 resides at the secondary (isolated) side of the adapter. It includes voltage and current feedback regulation eliminating the need for a shunt regulator such as TL431.

The NCP4371 provides charging current limits down to  $V_{BUS} = 2.2$  V protecting the portable device from excessive currents in case of a soft short-circuit condition.

The NCP4371 integrates a safe-discharge circuitry to quickly and reliably discharge output capacitors in case the USB cable is unplugged or connected to a 5 V only USB port.

### Features

- Supports Qualcomm Quick Charge 3.0 HVDCP Class A/B
- Output Voltage Can be Configured in Discreet Steps from
  - ◆ Class A: 3.6 V up to 12 V
  - ◆ Class B: 3.6 V up to 20 V
- Compatible with USB Battery Charging Specification Revision 1.2 (USB BC1.2)
- Constant Voltage and Constant Current Regulation
- Soft Short-Circuit Current Limitation Down to  $V_{BUS} = 2.2$  V
- Removes a Need for the Secondary Side Shunt Regulator such as TL431
- Output Capacitor Safe-Discharge Circuitry at Cable Unplug
- Fast Dynamic Response
- Built-in Power Limiting Function
- Low Supply Current
- Wide Operating Input Voltage Range: 2.2 V to 28 V
- These Devices are Pb-Free, Halogen Free/BFR Free and are RoHS Compliant

### Typical Applications

- Fast Charging AC/DC Adapters for Smart Phones, Tablets and Other Portable Devices



ON Semiconductor®

[www.onsemi.com](http://www.onsemi.com)



SOIC-8  
D SUFFIX  
CASE 751

### MARKING DIAGRAM

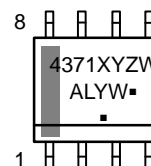

4371XYZW = Specific Device Code  
(See Device Options Table)

A = Assembly Location  
L = Wafer Lot  
Y = Year  
W = Work Week  
▪ = Pb-Free Package

### PIN CONNECTIONS

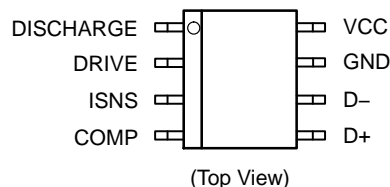

### ORDERING INFORMATION

See detailed ordering, marking and shipping information in the package dimensions section on page 13 of this data sheet.



# NCP4371

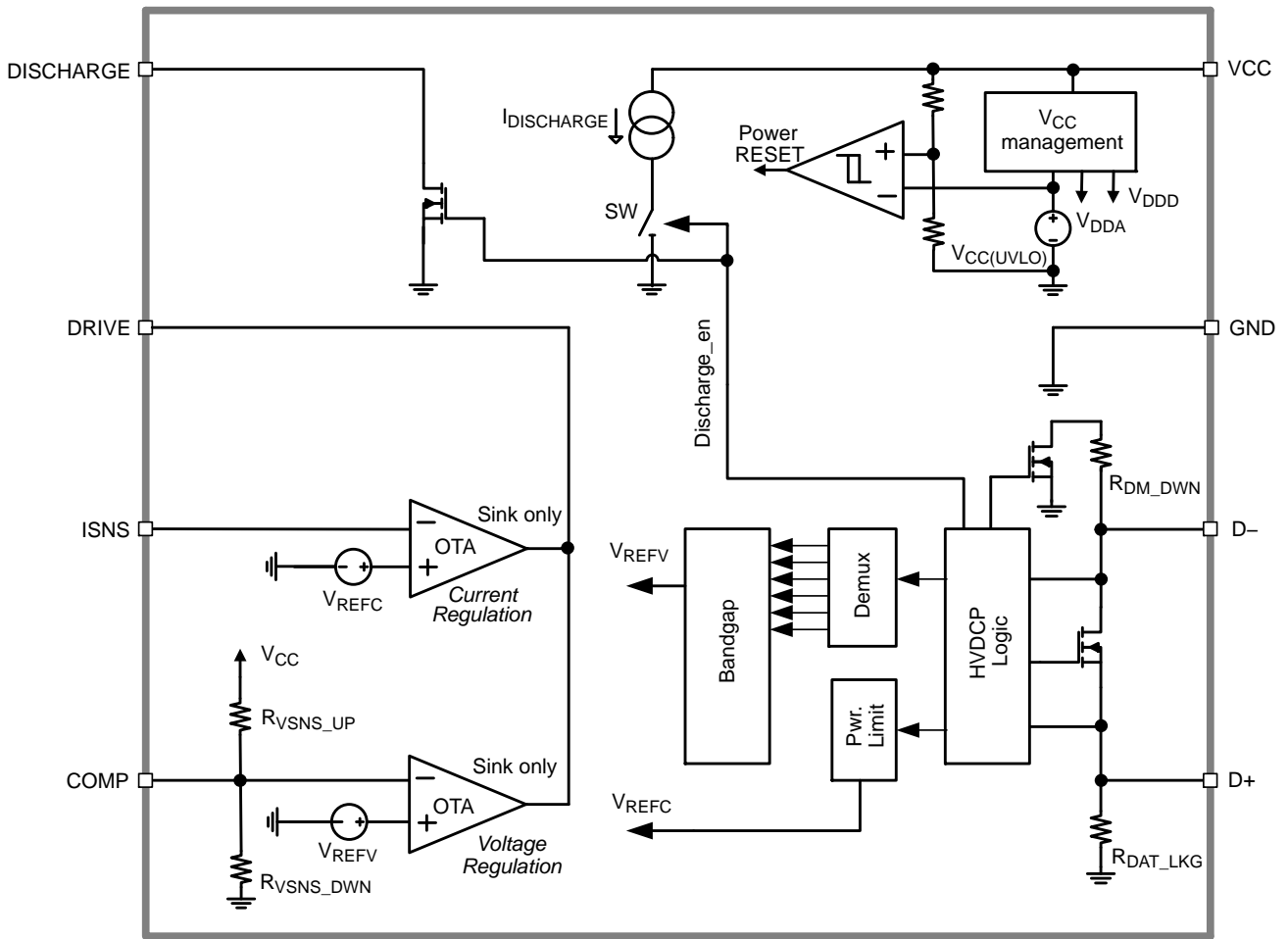

**Figure 2. Simplified Block Diagram**

**Table 1. PIN FUNCTION DESCRIPTION**

Pin No.	Pin Name	Description
1	DISCHARGE	This output is used to safely discharge $V_{BUS}$ output capacitors when an unplug event is detected
2	DRIVE	Output of current sinking OTA amplifier or amplifiers driving feedback optocoupler's LED. Connect here compensation network (networks) as well.
3	ISNS	Current sensing input for output current regulation, connect it to shunt resistor in ground branch.
4	COMP	Compensation pin of output voltage regulation, connected to a feedback compensation network.
5	D+	USB D+ Data Line Input
6	D-	USB D- Data Line Input
7	GND	Ground
8	VCC	Supply voltage pin

# NCP4371

**Table 2. MAXIMUM RATINGS**

Rating	Symbol	Value	Unit
Supply Voltage	$V_{CC}$	-0.3 to 28.0 $\pm 100$	V mA
DISCHARGE pin	$V_{DISCHARGE}$	-0.3 to $V_{CC}$ +500/-40	V mA
DRIVE pin	$V_{DRIVE}$	-0.3 to $V_{CC}$ +100/-90	V mA
D+, D-, VSNS, ISNS Input Voltage	$V_{D+}, V_{D-}, V_{VSNS}, V_{ISNS}$	-0.3 to 5.5 $\pm 100$	V mA
Junction to Air Thermal Resistance, SOIC8	$R_{\theta J-A, SOIC8}$	160	$^{\circ}C/W$
Maximum Junction Temperature	$T_{JMAX}$	125	$^{\circ}C$
Storage Temperature	$T_{STG}$	-60 to 150	$^{\circ}C$
ESD Capability, Human Body Model (Notes 1, 4)	ESD <sub>HBM</sub>	6000	V
ESD Capability, Machine Model (Note 1)	ESD <sub>MM</sub>	200	V
ESD Capability, Charged Device Model (Note 1)	ESD <sub>CDM</sub>	750	V

Stresses exceeding those listed in the Maximum Ratings table may damage the device. If any of these limits are exceeded, device functionality should not be assumed, damage may occur and reliability may be affected.

1. Refer to ELECTRICAL CHARACTERISTICS and APPLICATION INFORMATION for Safe Operating Area.
2. This device series incorporates ESD protection and is tested by the following methods:  
 ESD Human Body Model tested per AEC-Q100-002 (EIA/JESD22-A114)  
 ESD Machine Model tested per AEC-Q100-003 (EIA/JESD22-A115)  
 ESD Charged Device Model per JEDEC Standard JESD22-C101D  
 Latchup Current Maximum Rating <100 mA per JEDEC standard: JESD78 with respect to max. ratings table values
3. For information, please refer to our Soldering and Mounting Techniques Reference Manual, SOLDERRM/D
4. D+ vs. D- pin capability HBM 2500 V

**Table 3. ELECTRICAL CHARACTERISTICS**

-40 $^{\circ}C \leq T_J \leq 125^{\circ}C$ ;  $V_{CC} = 5 V$ ; unless otherwise noted. Typical values are at  $T_J = +25^{\circ}C$ .

Parameter	Test Conditions	Symbol	Min	Typ	Max	Unit
-----------	-----------------	--------	-----	-----	-----	------

**SUPPLY**

Minimum Operating Input Voltage	$V_{CC}$ voltage at which current limiting OTA is enabled	$V_{CC(min)}$	-	-	2.2	V
$V_{CC}$ HVDCP Logic Enable	$V_{CC}$ increasing level at which the HVDCP commands are accepted	$V_{CC(ON)}$	2.9	3.2	3.4	V
$V_{CC}$ HVDCP Logic Disable	$V_{CC}$ decreasing level at which the HVDCP commands are stopped to be accepted	$V_{CC(OFF)}$	2.7	3.0	3.2	V
Quiescent Current		$I_{CC}$			300	$\mu A$

**VOLTAGE CONTROL LOOP OTA**

Transconductance	Sink current only	$g_{mv}$	-	1	-	S
Voltage Control Reference Voltage	Nominal $V_{BUS} = 5 V$	$V_{REFV}$	1.21	1.25	1.29	V
Sink Current Capability		$I_{SINKV}$	2.0			mA
Output Voltage Sense Divider Resistor, Pull-Up		$R_{VSNS\_UP}$		66		k $\Omega$
Output Voltage Sense Divider Resistor, Pull-Down		$R_{VSNS\_DWN}$		24		k $\Omega$

**CURRENT CONTROL LOOP OTA**

Transconductance	Sink current only	$g_{mc}$	-	3	-	S
Current Control Reference Voltage	Current limit A reference set-point	$V_{REFC(A)}$	10	14	18	mV
	Current limit B reference set-point	$V_{REFC(B)}$	12	17	21	
	Current limit C reference set-point	$V_{REFC(C)}$	18	22	26	
	Current limit D reference set-point	$V_{REFC(D)}$	24	28	32	
	Current limit E reference set-point	$V_{REFC(E)}$	29	33	37	
	Current limit F reference set-point	$V_{REFC(F)}$	34	38	42	
	Current limit G reference set-point	$V_{REFC(G)}$	40	44	48	
	Current limit H reference set-point	$V_{REFC(H)}$	53	57	61	

# NCP4371

**Table 3. ELECTRICAL CHARACTERISTICS**

–40°C ≤ T<sub>J</sub> ≤ 125°C; V<sub>CC</sub> = 5 V; unless otherwise noted. Typical values are at T<sub>J</sub> = +25°C.

Parameter	Test Conditions	Symbol	Min	Typ	Max	Unit
<b>CURRENT CONTROL LOOP OTA</b>						
Sink Current Capability		I <sub>SINKC</sub>	2.0			mA
<b>HVDCP</b>						
Output Voltage Selection Reference		V <sub>SEL_REF</sub>	1.8	2	2.2	V
Data Detect Voltage		V <sub>DAT_REF</sub>	0.25	0.325	0.4	V
Data Line Leakage Resistance		R <sub>DAT_LKG</sub>	300	–	1500	kΩ
D– Pull–Down Resistance		R <sub>DM_DWN</sub>	14.25	19.53	24.8	kΩ
D+ to D– Resistance During DCP Mode		R <sub>DCP_DAT</sub>			45	Ω
<b>OUTPUT CAPACITOR DISCHARGER</b>						
Discharge Comparator OFF Voltage	V <sub>BUS_REF</sub> = 5 V, V <sub>DIS(OFF)</sub> sensed at VCC pin	V <sub>DIS(OFF)</sub>		5.2		mV
VCC Discharge Current	Discharge current of the internal current sink at the VCC pin	I <sub>DIS(VCC)</sub>			90	mA
DISCHARGE Pin Maximum Sink Current	Maximum sink current of the DISCHARGE pin Minimum recommended external discharge resistor value connected from V <sub>BUS</sub> to DISCHARGE pin is R <sub>DIS</sub> ≥ 70 Ω (Class A) R <sub>DIS</sub> ≥ 120 Ω (Class B)	I <sub>DIS(EXT)</sub>		150		mA

Product parametric performance is indicated in the Electrical Characteristics for the listed test conditions, unless otherwise noted. Product performance may not be indicated by the Electrical Characteristics if operated under different conditions.

# NCP4371

## TYPICAL CHARACTERISTICS

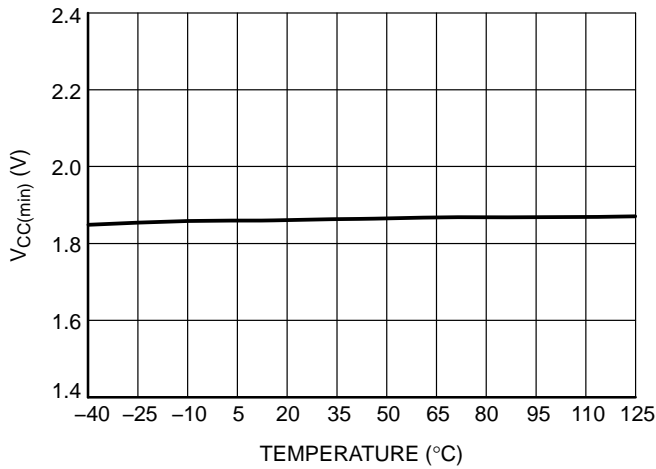

Figure 3. V<sub>CC</sub> Minimum Operating Input Voltage, V<sub>CC(min)</sub>

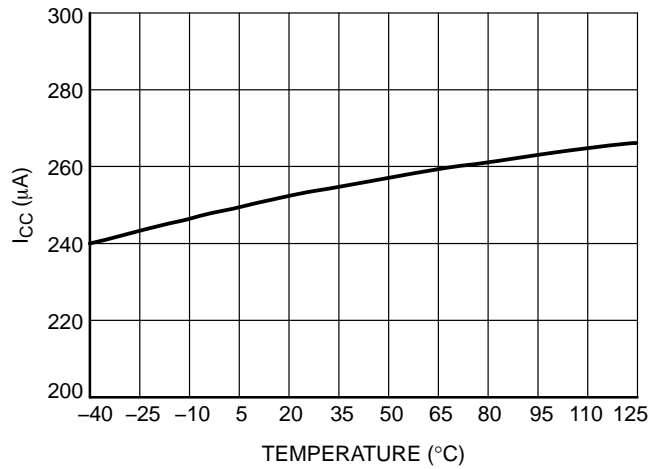

Figure 4. Quiescent Current, I<sub>CC</sub>

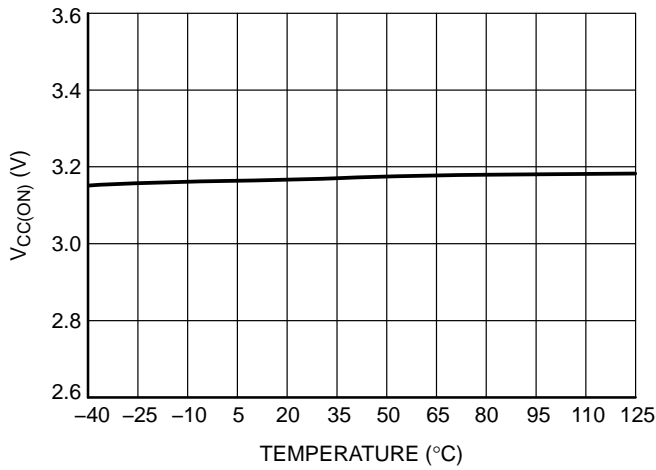

Figure 5. V<sub>CC</sub> HVDCP Logic Enable, V<sub>CC(ON)</sub>

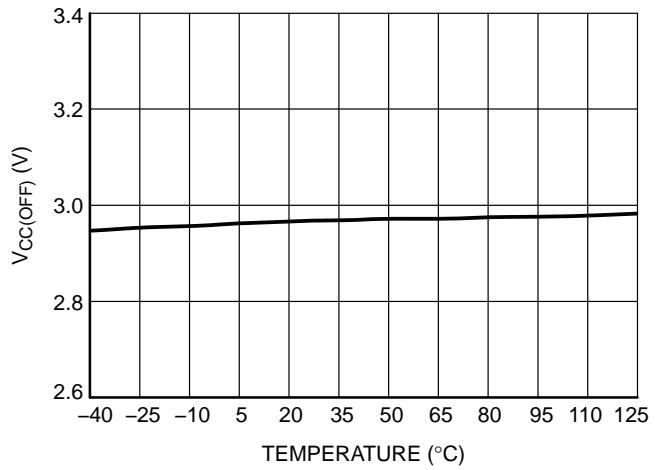

Figure 6. V<sub>CC</sub> HVDCP Logic Disable, V<sub>CC(OFF)</sub>

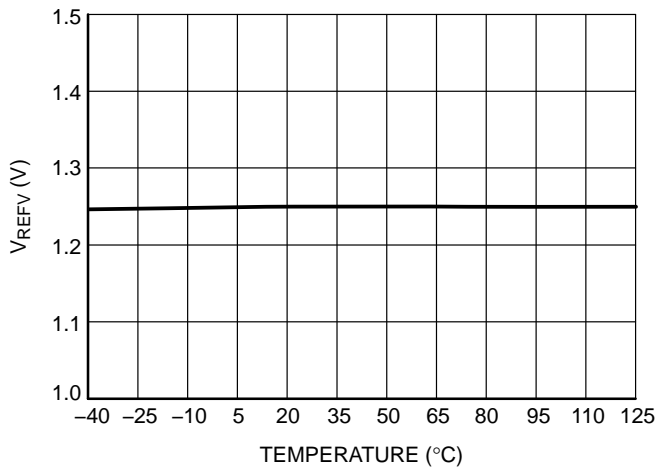

Figure 7. Voltage Control Reference Voltage, V<sub>REFV</sub>

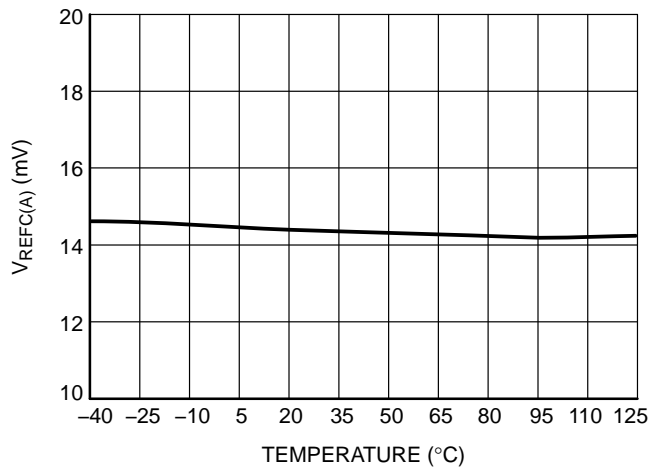

Figure 8. Current Control Reference Voltage, V<sub>REFC(A)</sub>

# NCP4371

## TYPICAL CHARACTERISTICS

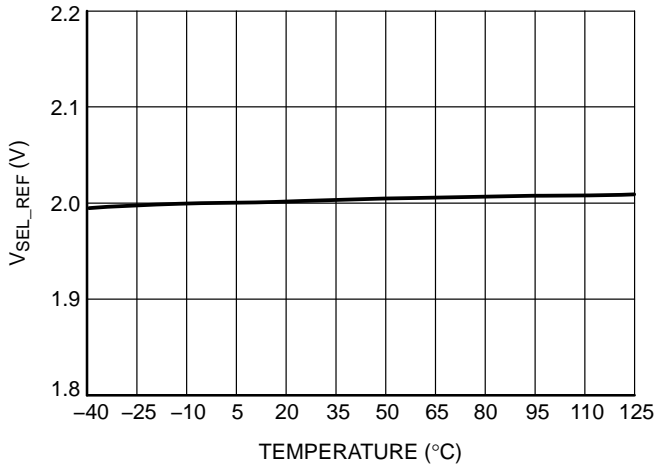

Figure 9. Output Voltage Selection Reference, V<sub>SEL\_REF</sub>

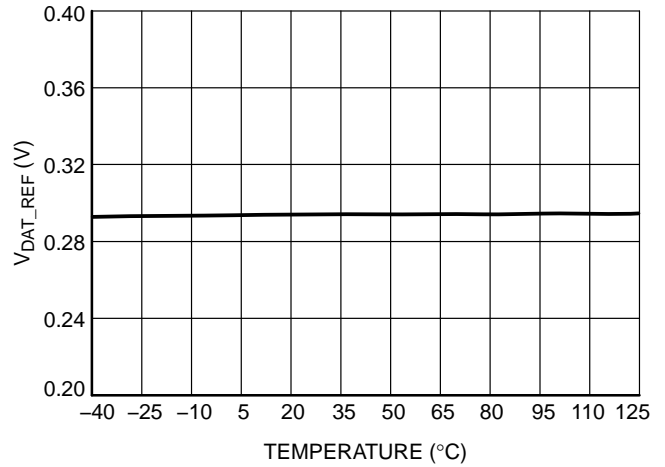

Figure 10. Data Detect Voltage, V<sub>DAT\_REF</sub>

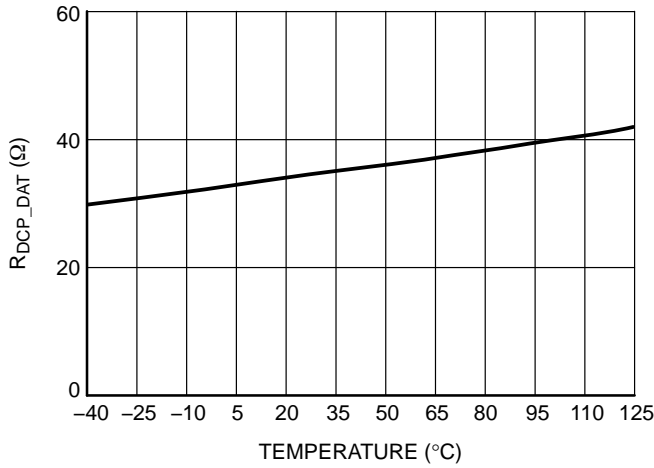

Figure 11. D+ to D- Resistance During DCP Mode, R<sub>DCP\_DAT</sub>

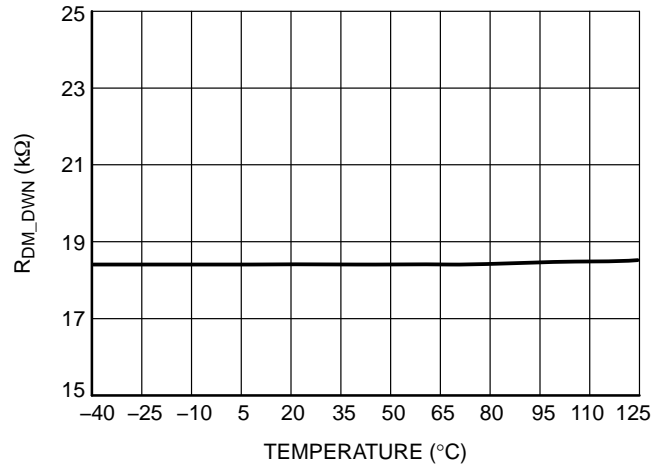

Figure 12. D- Pull-Down Resistance, R<sub>DM\_DWN</sub>

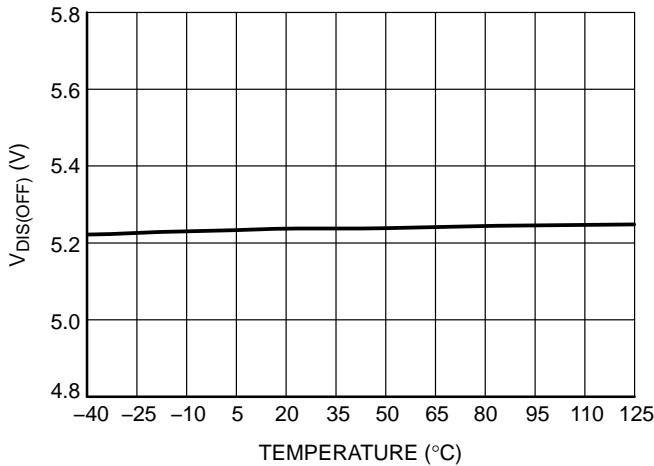

Figure 13. Discharge Comparator OFF Voltage, V<sub>DIS(OFF)</sub>

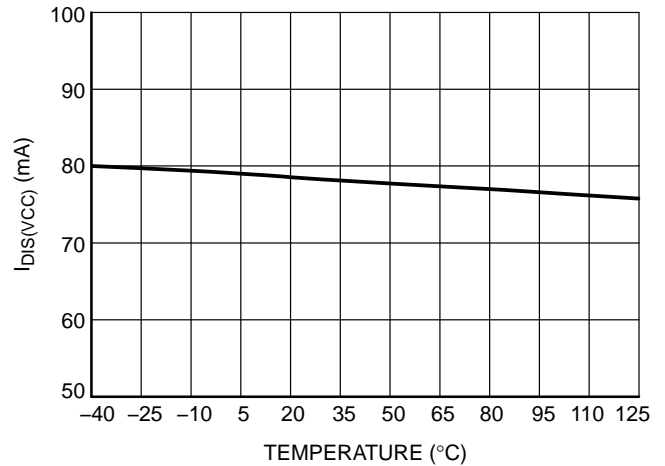

Figure 14. VCC Discharge Current, I<sub>DIS(VCC)</sub>

# NCP4371

## TYPICAL CHARACTERISTICS

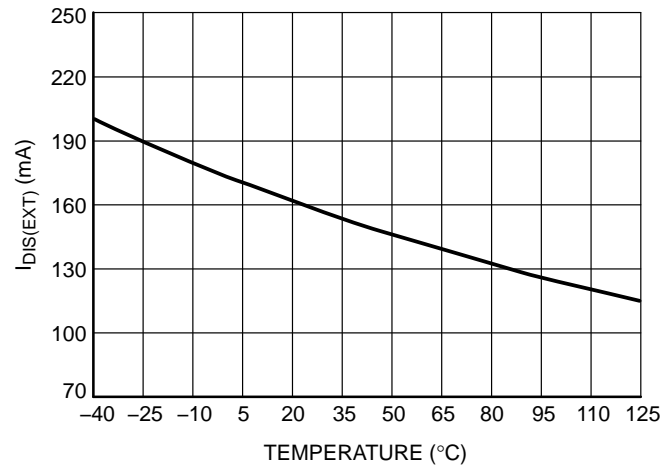

Figure 15. VCC Discharge Current,  $I_{DIS(EXT)}$

APPLICATION INFORMATION

The NCP4371 is designed to operate as an output voltage and current controller for USB chargers, which resides on the secondary side of the off-line adapter. It enables to accommodate the output voltage based on the request from the portable device in order to optimize the battery charge time. The NCP4371 is compatible with Qualcomm Quick Charge 3.0 HVDCP specification. The output voltage can be increased or decreased in discrete steps. The output current is limited not to exceed the maximum power limit for given output voltage level. The internal discharge switch discharges the output capacitors to a safe voltage level in a case of the cable unplug.

**Voltage Regulation**

The Voltage Regulation Path eliminates a need for a voltage shunt regulator at the secondary side of the off-line supply. The voltage on VCC pin is divided by internal resistor divider ( $R_{VSNS\_UP}$ ,  $R_{VSNS\_DWN}$ ) and compared with the internal precise voltage reference  $V_{REFV}$ . The voltage difference is amplified by  $g_{mV}$  of the transconductance amplifier. The amplifier output current is connected to the DRIVE pin. This DRIVE pin drives regulation optocoupler that provides regulation of primary side. The internal voltage reference  $V_{REFV}$  is adjustable based on the command from the Portable Device compatible with Qualcomm Quick Charge specification. The voltage control loop compensation network shall be connected between DRIVE and COMP pins.

**Current Regulation**

The output current is sensed by the shunt resistor  $R_{SENSE}$  in series with the load. Voltage drop on  $R_{SENSE}$  is compared with internal precise voltage reference  $V_{REFC}$  at ISNS transconductance amplifier input. Voltage difference is amplified by  $g_{mC}$  to output current of amplifier, connected to the DRIVE pin.

**HVDCP Mode**

After power-up pins D+ and D- of NCP4371 are shorted with impedance  $R_{DCP\_DAT}$  and internal reference voltage  $V_{REFV}$  is set to  $V_{BUS}$  voltage 5 V. The device is in a BC1.2 compatible mode. If a portable device compatible with the Qualcomm Quick Charge specification is connected a negotiation between HVDCP and PD is executed. Once the negotiation is successful the NCP4371 opens D+ and D- short connection and D- is pulled down with a  $R_{DM\_DWN}$ . The NCP4371 enters HVDCP mode. It monitors D+ and D- inputs. Based on the specified control patterns the internal voltage reference value  $V_{REFV}$  is adjusted in order to increase or decrease output voltage to the required value. The NCP4371 is available in Class A and Class B version. Class A allows to change the output voltage up to  $V_{BUS} = 12$  V. Class B allows output voltage up to 20 V. If the unplug event is detected the decoder circuitry turns-on an internal current sink, which discharges the output capacitors to a safe voltage level. If the NCP4371 is set to a

Continuous mode it responds to the PD requests in a Single request mode. It does not support Group request mode.

**Table 4. D+ AND D- OUTPUT VOLTAGE CODING**

Portable Device		HVDCP Class A	HVDCP Class B
D+	D-	Adapter Voltage	Adapter Voltage
0.6 V	0.6 V	12 V	12 V
3.3 V	0.6 V	9 V	9 V
0.6 V	3.3 V	Continuous mode	Continuous mode
3.3 V	3.3 V	Previous voltage	20 V
0.6 V	GND	5 V	5V

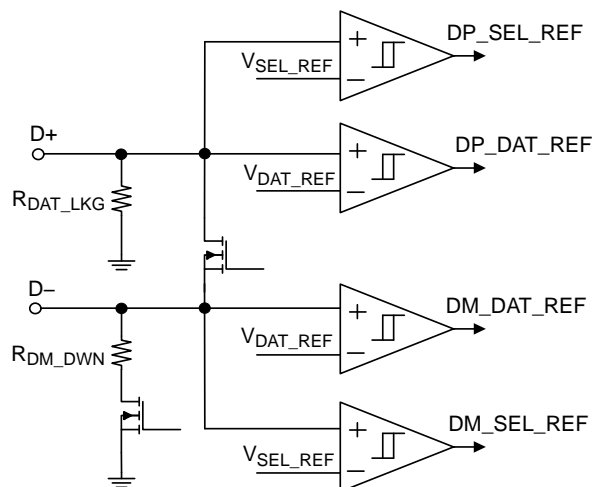

**Figure 16. HVDCP D+ and D- Comparators**

**HVDCP Mode – Continuous Mode**

The continuous mode of operation leverages the previously unused state in QC2.0. If the portable devices try and utilize this mode, it applies voltages on D+ and D- per Table 4. Assuming the HVDCP supports this mode of operation, it will glitch filter the request as it currently does, using  $T_{GLITCH\_V\_CHANGE}$ . Before the portable device can begin to increment or decrement the voltage, it must wait  $T_{V\_NEW\_REQUEST\_CONT}$  before pulling D+ and D- high or low. Once this time has finished, the portable device now attempts to increment or decrement the voltage. To increment, the portable device sends a pulse of width  $T_{ACTIVE}$  by pulling D+ to  $V_{DP\_UP}$  and then must return D+ to  $V_{DP\_SRC}$  for  $T_{INACTIVE}$ .

The NCP4371 responds to the increment/decrement request in a single request mode, i.e. the output voltage is changed immediately with each request. For the single request, and HVDCP recognizes a rising edge on D+ for an increment, and falling edge on D- for a decrement, and glitch filters this with  $T_{GLITCH\_CONT\_CHANGE}$ . After this period, it begins changing its output voltage by incrementing or decrementing in a 200 mV step. The output voltage is at its final value within  $T_{V\_CONT\_CHANGE\_SINGLE}$ .

# NCP4371

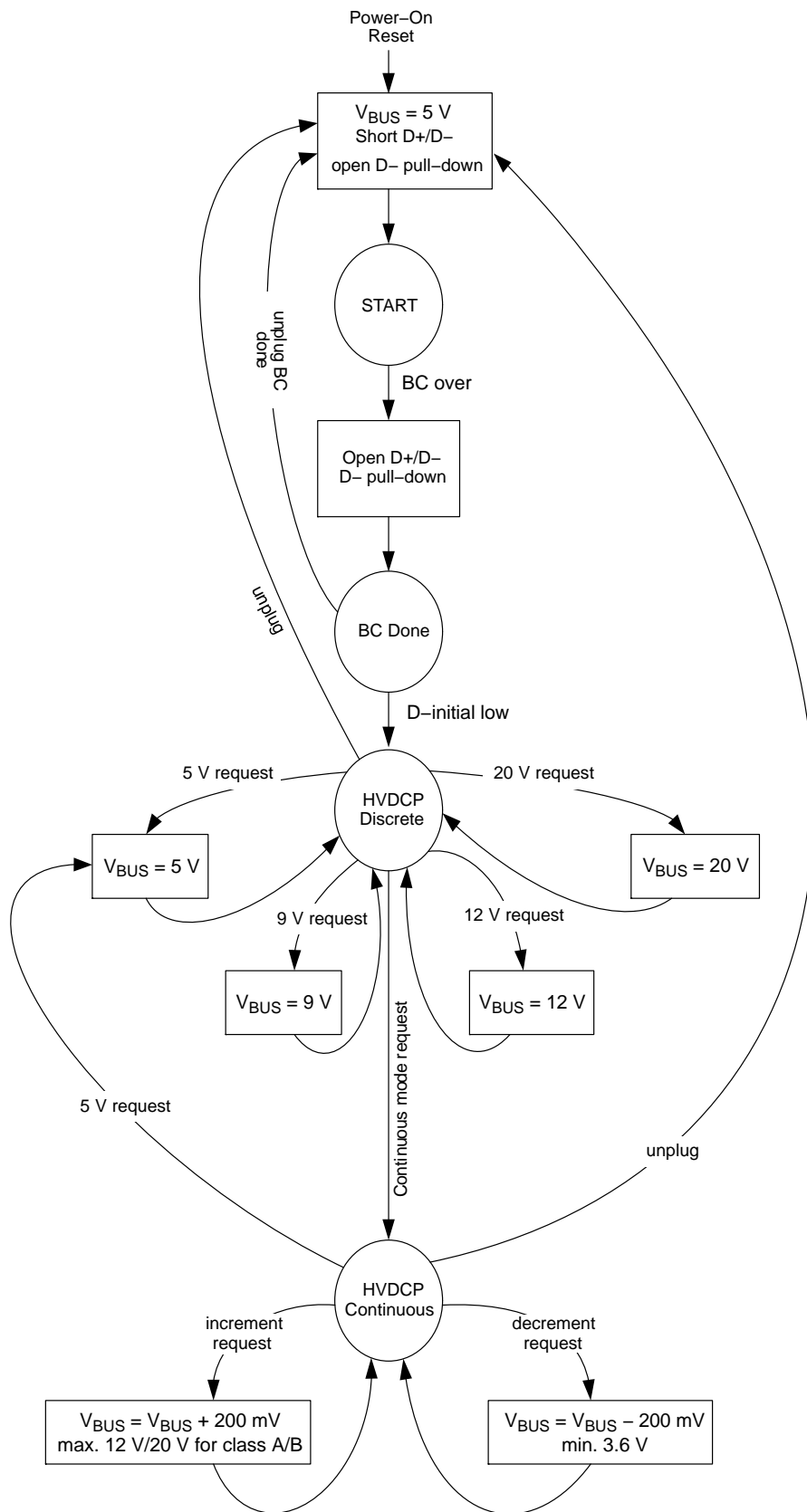

Figure 17. NCP4371 State Diagram

**Power Limit**

The protocol decoder and the power limit logic will limit maximum output current to keep regulation within recommended  $V_{out}/I_{out}$  operating range. The Power Limit block adjusts  $V_{REFC}$  voltage reference at the current regulation loop in order to limit the maximum output current.

The NCP4371 is designed to give a user a high degree of freedom to optimize maximum power and current limit profile of the target application. The user can scale both – maximum output power and maximum current limit independently.

The NCP4371 has two constant power curves defined – “Option A” for Class A only and “Option B” for either Class A or Class B. Power Option C shall be used for applications where constant power regulation is not required. If Power Option C is selected then power limiting curve is ignored. The applications based on Power Option C operate in “constant current regulation mode”.

In order to scale the power limit curve for the given power a selection of the current sense resistor has to be done. The relation between current sense resistor and output power limit is given by the curves in Figure 18.

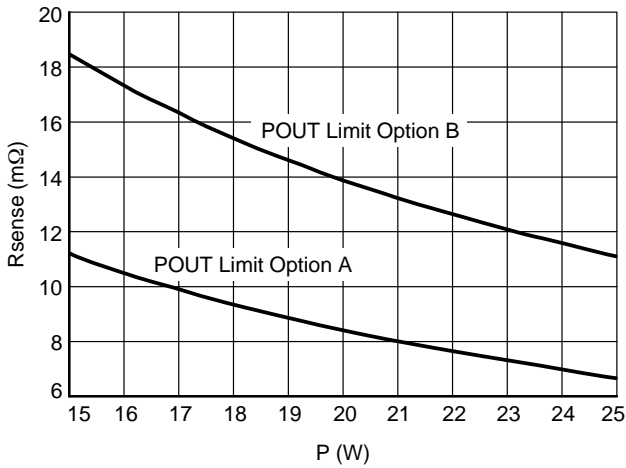

**Figure 18. R<sub>SENSE</sub> vs. P<sub>OUT</sub> Limit Curve**

The characteristics in the Figure 23 cover a range  $P_{OUT} = 15 - 25$  W. For powers outside this interval following formula can be used for  $R_{SENSE}$  selection:

Option A (Class A only) :  $R_{SENSE} = \frac{168}{P_{max}} [m\Omega]$  (eq. 1)

Option B (Class A & B) :  $R_{SENSE} = \frac{277}{P_{max}} [m\Omega]$  (eq. 2)

Once the Power limit is defined by an  $R_{SENSE}$  selection the user needs to define a maximum output current limit. This current limit can be given by a connector or cable maximum current rating.

There are 5 current limit options available for Power Option A and 8 current limit options for Power Option B and C. Each power limit option corresponds to a particular Current Control Reference Voltage ( $V_{REFC}$ ), which limits the maximum output current for the selected  $R_{SENSE}$  resistor. The user has to make a selection from current limit characteristics shown in Figure 19. Each power limit curve represents a unique device option (see Table Device Options).

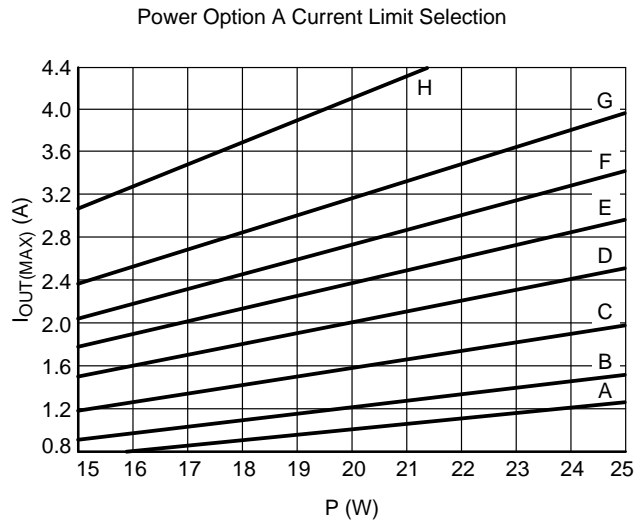
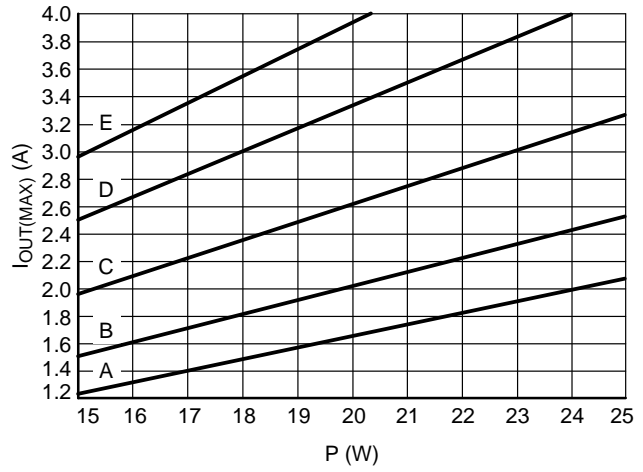

**Figure 19. Current Limit Characteristics**

Table 5. CURRENT LIMIT OPTION REFERENCE VOLTAGE

Current Limit Option	A	B	C	D	E	F	G	H
$V_{REFC}[mV]$	14	17	22	28	33	38	44	57

**Soft Short–Circuit Protection**

In case of a short–circuit at the USB cable end or the portable device USB receptacle it is desired to limit the short circuit current to prevent a portable device or cable from a damage. The NCP4371 offers an extended region of output current limiting down to  $V_{BUS} = 2.2\text{ V}$ . If the  $V_{BUS}$  falls below  $V_{CC(OFF)}$  then the HVDCP logic is disabled and D+/- pins are shorted. No further commands from the portable device are accepted. The only feature enabled is the output current limiting at the moment. The device stays in the current limiting mode until  $V_{CC}$  rises back above  $V_{CC(ON)}$  threshold. The device logic will resume its operation and goes to a default BC1.2 compatible mode. A new negotiation between the charger and portable device has to be carried out in order to enable HVDCP compatibility mode.

**Discharge**

If voltage level lower than actual  $V_{BUS}$  is requested by PD the discharge circuitry discharges the output capacitors to reach the new voltage level in a short time. As well, the discharge circuitry is activated if cable unplug event is detected. The NCP4371 features two discharge paths. By default, the discharge is done via built–in regulated current source at VCC pin. If the VCC pin discharge capability is not sufficient an external discharge resistor  $R_{DIS}$  has to be used.

The discharge resistor is wired from a positive pole of the output capacitor to the DISCHARGE pin. The minimum recommended value of the discharge resistor  $R_{DIS}$  is  $70\ \Omega$  for Class A and  $120\ \Omega$  for Class B. The DISCHARGE pin has an internal protection for a case the user wires the pin directly to  $V_{BUS}$ . If this condition is detected the discharge MOSFET at the pin is turned off. It is highly recommended to use an external discharge resistor always if Class B device is used. In case of Class A device and  $C_{OUT} < 1500\ \mu F$  the DISCHARGE pin can be left disconnected.

**Dual Discharge Path**

The NCP4371 allows to select between a single discharge path and the dual discharge. By default, if an external discharge resistor  $R_{DIS}$  is connected between a positive pole of the output capacitor and the DISCHARGE pin, the NCP4371 recognize it and the internal discharge path via VCC pin is disabled. Some applications may require even stronger discharge capability or may need to discharge two capacitors connected at two different nodes (USB–Type C output capacitors before and after VBUS switch). The NCP4371 allows to enable a simultaneous function of internal discharge via VCC pin and external DISCHARGE pin. Figure 20 shows an application idea of the dual discharge paths in the USB–Type C adapter design.

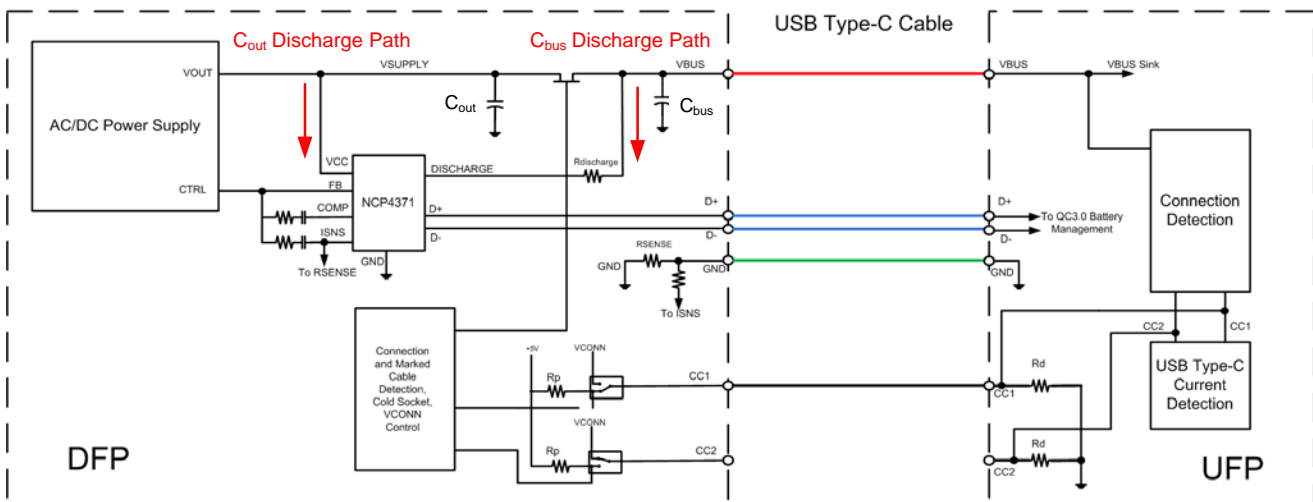

Figure 20. Dual Discharge Path – Application Idea (USB–Type C Adapter)

# NCP4371

**Table 6. DEVICE OPTIONS**

OPN # NCP4371xyzwDR2G	QuickCharge Class A/B X		Power Limit Y			Current Limit (mV) Z								Discharge W	
	A	B	A	B	C	A	B	C	D	E	F	G	H	S	D
	Class A	Class B	Class A	Class A&B	No Power Limit	14	17	22	28	33	38	44	57	Single	Dual
NCP4371AACDR2G	X		X					X						X	
NCP4371AAEDR2G	X		X							X				X	
NCP4371AADDR2G	X		X						X					X	
NCP4371ACCDR2G	X				X			X						X	
NCP4371BBEDR2G		X		X						X				X	
NCP4371BBCDDR2G		X		X				X							X

NOTE: Device option with 4371XYZ marking are single discharge path version exclusively.

## ORDERING INFORMATION

Device	Marking	Package	Shipping†
NCP4371AACDR2G	4371AAC	SOIC-8 (Pb-Free)	2500 / Tape & Reel
NCP4371AAEDR2G	4371AAE		
NCP4371AADDR2G	4371AAD		
NCP4371ACCDR2G	4371ACC		
NCP4371BBEDR2G	4371BBE		
NCP4371BBCDDR2G	4371BBCD		

†For information on tape and reel specifications, including part orientation and tape sizes, please refer to our Tape and Reel Packaging Specifications Brochure, BRD8011/D.

# MECHANICAL CASE OUTLINE PACKAGE DIMENSIONS



SCALE 1:1

SOIC-8 NB  
CASE 751-07  
ISSUE AK

DATE 16 FEB 2011

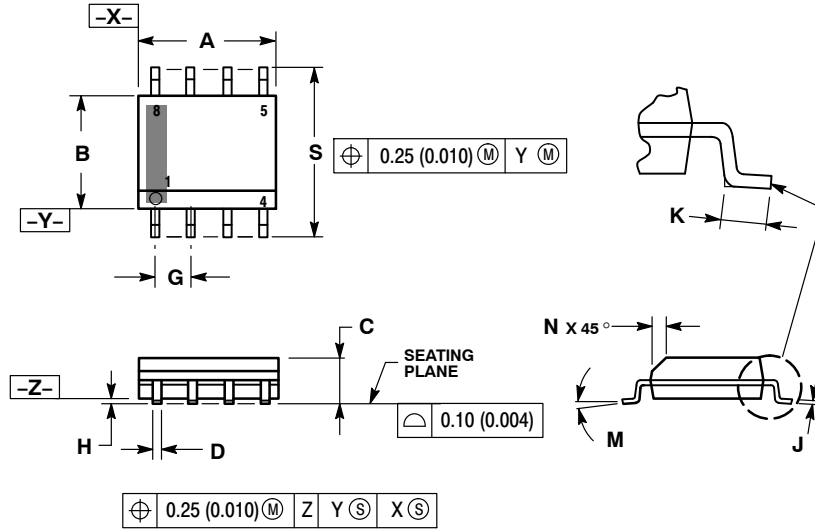

- NOTES:
1. DIMENSIONING AND TOLERANCING PER ANSI Y14.5M, 1982.
  2. CONTROLLING DIMENSION: MILLIMETER.
  3. DIMENSION A AND B DO NOT INCLUDE MOLD PROTRUSION.
  4. MAXIMUM MOLD PROTRUSION 0.15 (0.006) PER SIDE.
  5. DIMENSION D DOES NOT INCLUDE DAMBAR PROTRUSION. ALLOWABLE DAMBAR PROTRUSION SHALL BE 0.127 (0.005) TOTAL IN EXCESS OF THE D DIMENSION AT MAXIMUM MATERIAL CONDITION.
  6. 751-01 THRU 751-06 ARE OBSOLETE. NEW STANDARD IS 751-07.

DIM	MILLIMETERS		INCHES	
	MIN	MAX	MIN	MAX
A	4.80	5.00	0.189	0.197
B	3.80	4.00	0.150	0.157
C	1.35	1.75	0.053	0.069
D	0.33	0.51	0.013	0.020
G	1.27 BSC		0.050 BSC	
H	0.10	0.25	0.004	0.010
J	0.19	0.25	0.007	0.010
K	0.40	1.27	0.016	0.050
M	0°	8°	0°	8°
N	0.25	0.50	0.010	0.020
S	5.80	6.20	0.228	0.244

## GENERIC MARKING DIAGRAM\*

### SOLDERING FOOTPRINT\*

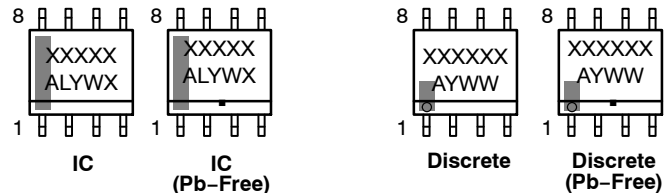
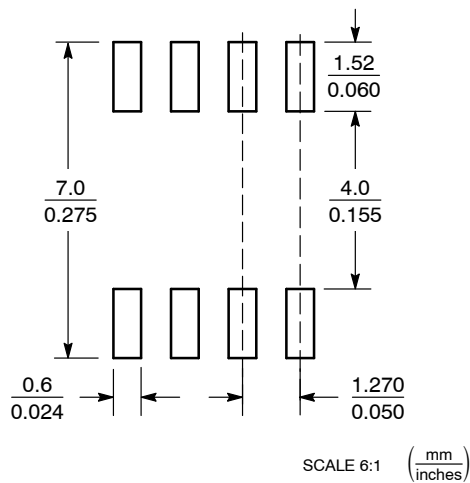

XXXXXX = Specific Device Code  
A = Assembly Location  
L = Wafer Lot  
Y = Year  
W = Work Week  
▪ = Pb-Free Package

XXXXXX = Specific Device Code  
A = Assembly Location  
Y = Year  
WW = Work Week  
▪ = Pb-Free Package

\*This information is generic. Please refer to device data sheet for actual part marking. Pb-Free indicator, "G" or microdot "▪", may or may not be present. Some products may not follow the Generic Marking.

\*For additional information on our Pb-Free strategy and soldering details, please download the ON Semiconductor Soldering and Mounting Techniques Reference Manual, SOLDERRM/D.

## STYLES ON PAGE 2

DOCUMENT NUMBER:	98ASB42564B	Electronic versions are uncontrolled except when accessed directly from the Document Repository. Printed versions are uncontrolled except when stamped "CONTROLLED COPY" in red.
DESCRIPTION:	SOIC-8 NB	PAGE 1 OF 2

onsemi and ONsemi are trademarks of Semiconductor Components Industries, LLC dba onsemi or its subsidiaries in the United States and/or other countries. onsemi reserves the right to make changes without further notice to any products herein. onsemi makes no warranty, representation or guarantee regarding the suitability of its products for any particular purpose, nor does onsemi assume any liability arising out of the application or use of any product or circuit, and specifically disclaims any and all liability, including without limitation special, consequential or incidental damages. onsemi does not convey any license under its patent rights nor the rights of others.

**SOIC-8 NB**  
**CASE 751-07**  
**ISSUE AK**

DATE 16 FEB 2011

- |   |  |  |  |
|---|--|--|--|
| <p>STYLE 1:<br/>         PIN 1. EMITTER<br/>         2. COLLECTOR<br/>         3. COLLECTOR<br/>         4. EMITTER<br/>         5. EMITTER<br/>         6. BASE<br/>         7. BASE<br/>         8. EMITTER</p>   | <p>STYLE 2:<br/>         PIN 1. COLLECTOR, DIE, #1<br/>         2. COLLECTOR, #1<br/>         3. COLLECTOR, #2<br/>         4. COLLECTOR, #2<br/>         5. BASE, #2<br/>         6. EMITTER, #2<br/>         7. BASE, #1<br/>         8. EMITTER, #1</p>               | <p>STYLE 3:<br/>         PIN 1. DRAIN, DIE #1<br/>         2. DRAIN, #1<br/>         3. DRAIN, #2<br/>         4. DRAIN, #2<br/>         5. GATE, #2<br/>         6. SOURCE, #2<br/>         7. GATE, #1<br/>         8. SOURCE, #1</p>                            | <p>STYLE 4:<br/>         PIN 1. ANODE<br/>         2. ANODE<br/>         3. ANODE<br/>         4. ANODE<br/>         5. ANODE<br/>         6. ANODE<br/>         7. ANODE<br/>         8. COMMON CATHODE</p>   |
| <p>STYLE 5:<br/>         PIN 1. DRAIN<br/>         2. DRAIN<br/>         3. DRAIN<br/>         4. DRAIN<br/>         5. GATE<br/>         6. GATE<br/>         7. SOURCE<br/>         8. SOURCE</p>   | <p>STYLE 6:<br/>         PIN 1. SOURCE<br/>         2. DRAIN<br/>         3. DRAIN<br/>         4. SOURCE<br/>         5. SOURCE<br/>         6. GATE<br/>         7. GATE<br/>         8. SOURCE</p>  | <p>STYLE 7:<br/>         PIN 1. INPUT<br/>         2. EXTERNAL BYPASS<br/>         3. THIRD STAGE SOURCE<br/>         4. GROUND<br/>         5. DRAIN<br/>         6. GATE 3<br/>         7. SECOND STAGE Vd<br/>         8. FIRST STAGE Vd</p>                    | <p>STYLE 8:<br/>         PIN 1. COLLECTOR, DIE #1<br/>         2. BASE, #1<br/>         3. BASE, #2<br/>         4. COLLECTOR, #2<br/>         5. COLLECTOR, #2<br/>         6. EMITTER, #2<br/>         7. EMITTER, #1<br/>         8. COLLECTOR, #1</p>                              |
| <p>STYLE 9:<br/>         PIN 1. EMITTER, COMMON<br/>         2. COLLECTOR, DIE #1<br/>         3. COLLECTOR, DIE #2<br/>         4. EMITTER, COMMON<br/>         5. EMITTER, COMMON<br/>         6. BASE, DIE #2<br/>         7. BASE, DIE #1<br/>         8. EMITTER, COMMON</p> | <p>STYLE 10:<br/>         PIN 1. GROUND<br/>         2. BIAS 1<br/>         3. OUTPUT<br/>         4. GROUND<br/>         5. GROUND<br/>         6. BIAS 2<br/>         7. INPUT<br/>         8. GROUND</p>  | <p>STYLE 11:<br/>         PIN 1. SOURCE 1<br/>         2. GATE 1<br/>         3. SOURCE 2<br/>         4. GATE 2<br/>         5. DRAIN 2<br/>         6. DRAIN 2<br/>         7. DRAIN 1<br/>         8. DRAIN 1</p>   | <p>STYLE 12:<br/>         PIN 1. SOURCE<br/>         2. SOURCE<br/>         3. SOURCE<br/>         4. GATE<br/>         5. DRAIN<br/>         6. DRAIN<br/>         7. DRAIN<br/>         8. DRAIN</p>   |
| <p>STYLE 13:<br/>         PIN 1. N.C.<br/>         2. SOURCE<br/>         3. SOURCE<br/>         4. GATE<br/>         5. DRAIN<br/>         6. DRAIN<br/>         7. DRAIN<br/>         8. DRAIN</p>  | <p>STYLE 14:<br/>         PIN 1. N-SOURCE<br/>         2. N-GATE<br/>         3. P-SOURCE<br/>         4. P-GATE<br/>         5. P-DRAIN<br/>         6. P-DRAIN<br/>         7. N-DRAIN<br/>         8. N-DRAIN</p>   | <p>STYLE 15:<br/>         PIN 1. ANODE 1<br/>         2. ANODE 1<br/>         3. ANODE 1<br/>         4. ANODE 1<br/>         5. CATHODE, COMMON<br/>         6. CATHODE, COMMON<br/>         7. CATHODE, COMMON<br/>         8. CATHODE, COMMON</p>               | <p>STYLE 16:<br/>         PIN 1. EMITTER, DIE #1<br/>         2. BASE, DIE #1<br/>         3. EMITTER, DIE #2<br/>         4. BASE, DIE #2<br/>         5. COLLECTOR, DIE #2<br/>         6. COLLECTOR, DIE #2<br/>         7. COLLECTOR, DIE #1<br/>         8. COLLECTOR, DIE #1</p> |
| <p>STYLE 17:<br/>         PIN 1. VCC<br/>         2. V2OUT<br/>         3. V1OUT<br/>         4. TXE<br/>         5. RXE<br/>         6. VEE<br/>         7. GND<br/>         8. ACC</p>  | <p>STYLE 18:<br/>         PIN 1. ANODE<br/>         2. ANODE<br/>         3. SOURCE<br/>         4. GATE<br/>         5. DRAIN<br/>         6. DRAIN<br/>         7. CATHODE<br/>         8. CATHODE</p>   | <p>STYLE 19:<br/>         PIN 1. SOURCE 1<br/>         2. GATE 1<br/>         3. SOURCE 2<br/>         4. GATE 2<br/>         5. DRAIN 2<br/>         6. MIRROR 2<br/>         7. DRAIN 1<br/>         8. MIRROR 1</p>   | <p>STYLE 20:<br/>         PIN 1. SOURCE (N)<br/>         2. GATE (N)<br/>         3. SOURCE (P)<br/>         4. GATE (P)<br/>         5. DRAIN<br/>         6. DRAIN<br/>         7. DRAIN<br/>         8. DRAIN</p>   |
| <p>STYLE 21:<br/>         PIN 1. CATHODE 1<br/>         2. CATHODE 2<br/>         3. CATHODE 3<br/>         4. CATHODE 4<br/>         5. CATHODE 5<br/>         6. COMMON ANODE<br/>         7. COMMON ANODE<br/>         8. CATHODE 6</p>  | <p>STYLE 22:<br/>         PIN 1. I/O LINE 1<br/>         2. COMMON CATHODE/VCC<br/>         3. COMMON CATHODE/VCC<br/>         4. I/O LINE 3<br/>         5. COMMON ANODE/GND<br/>         6. I/O LINE 4<br/>         7. I/O LINE 5<br/>         8. COMMON ANODE/GND</p> | <p>STYLE 23:<br/>         PIN 1. LINE 1 IN<br/>         2. COMMON ANODE/GND<br/>         3. COMMON ANODE/GND<br/>         4. LINE 2 IN<br/>         5. LINE 2 OUT<br/>         6. COMMON ANODE/GND<br/>         7. COMMON ANODE/GND<br/>         8. LINE 1 OUT</p> | <p>STYLE 24:<br/>         PIN 1. BASE<br/>         2. EMITTER<br/>         3. COLLECTOR/ANODE<br/>         4. COLLECTOR/ANODE<br/>         5. CATHODE<br/>         6. CATHODE<br/>         7. COLLECTOR/ANODE<br/>         8. COLLECTOR/ANODE</p>                                      |
| <p>STYLE 25:<br/>         PIN 1. VIN<br/>         2. N/C<br/>         3. REXT<br/>         4. GND<br/>         5. IOUT<br/>         6. IOUT<br/>         7. IOUT<br/>         8. IOUT</p>   | <p>STYLE 26:<br/>         PIN 1. GND<br/>         2. dv/dt<br/>         3. ENABLE<br/>         4. ILIMIT<br/>         5. SOURCE<br/>         6. SOURCE<br/>         7. SOURCE<br/>         8. VCC</p>  | <p>STYLE 27:<br/>         PIN 1. ILIMIT<br/>         2. OVLO<br/>         3. UVLO<br/>         4. INPUT+<br/>         5. SOURCE<br/>         6. SOURCE<br/>         7. SOURCE<br/>         8. DRAIN</p>  | <p>STYLE 28:<br/>         PIN 1. SW_TO_GND<br/>         2. DASIC_OFF<br/>         3. DASIC_SW_DET<br/>         4. GND<br/>         5. V_MON<br/>         6. VBULK<br/>         7. VBULK<br/>         8. VIN</p>  |
| <p>STYLE 29:<br/>         PIN 1. BASE, DIE #1<br/>         2. EMITTER, #1<br/>         3. BASE, #2<br/>         4. EMITTER, #2<br/>         5. COLLECTOR, #2<br/>         6. COLLECTOR, #2<br/>         7. COLLECTOR, #1<br/>         8. COLLECTOR, #1</p>                        | <p>STYLE 30:<br/>         PIN 1. DRAIN 1<br/>         2. DRAIN 1<br/>         3. GATE 2<br/>         4. SOURCE 2<br/>         5. SOURCE 1/DRAIN 2<br/>         6. SOURCE 1/DRAIN 2<br/>         7. SOURCE 1/DRAIN 2<br/>         8. GATE 1</p>                           |  |  |

<b>DOCUMENT NUMBER:</b>	<b>98ASB42564B</b>	Electronic versions are uncontrolled except when accessed directly from the Document Repository. Printed versions are uncontrolled except when stamped "CONTROLLED COPY" in red.
<b>DESCRIPTION:</b>	<b>SOIC-8 NB</b>	<b>PAGE 2 OF 2</b>

**onsemi** and **ONSEMI** are trademarks of Semiconductor Components Industries, LLC dba **onsemi** or its subsidiaries in the United States and/or other countries. **onsemi** reserves the right to make changes without further notice to any products herein. **onsemi** makes no warranty, representation or guarantee regarding the suitability of its products for any particular purpose, nor does **onsemi** assume any liability arising out of the application or use of any product or circuit, and specifically disclaims any and all liability, including without limitation special, consequential or incidental damages. **onsemi** does not convey any license under its patent rights nor the rights of others.

**onsemi**, **Onsemi**, and other names, marks, and brands are registered and/or common law trademarks of Semiconductor Components Industries, LLC dba "**onsemi**" or its affiliates and/or subsidiaries in the United States and/or other countries. **onsemi** owns the rights to a number of patents, trademarks, copyrights, trade secrets, and other intellectual property. A listing of **onsemi**'s product/patent coverage may be accessed at [www.onsemi.com/site/pdf/Patent-Marking.pdf](http://www.onsemi.com/site/pdf/Patent-Marking.pdf). **onsemi** reserves the right to make changes at any time to any products or information herein, without notice. The information herein is provided "as-is" and **onsemi** makes no warranty, representation or guarantee regarding the accuracy of the information, product features, availability, functionality, or suitability of its products for any particular purpose, nor does **onsemi** assume any liability arising out of the application or use of any product or circuit, and specifically disclaims any and all liability, including without limitation special, consequential or incidental damages. Buyer is responsible for its products and applications using **onsemi** products, including compliance with all laws, regulations and safety requirements or standards, regardless of any support or applications information provided by **onsemi**. "Typical" parameters which may be provided in **onsemi** data sheets and/or specifications can and do vary in different applications and actual performance may vary over time. All operating parameters, including "Typicals" must be validated for each customer application by customer's technical experts. **onsemi** does not convey any license under any of its intellectual property rights nor the rights of others. **onsemi** products are not designed, intended, or authorized for use as a critical component in life support systems or any FDA Class 3 medical devices or medical devices with a same or similar classification in a foreign jurisdiction or any devices intended for implantation in the human body. Should Buyer purchase or use **onsemi** products for any such unintended or unauthorized application, Buyer shall indemnify and hold **onsemi** and its officers, employees, subsidiaries, affiliates, and distributors harmless against all claims, costs, damages, and expenses, and reasonable attorney fees arising out of, directly or indirectly, any claim of personal injury or death associated with such unintended or unauthorized use, even if such claim alleges that **onsemi** was negligent regarding the design or manufacture of the part. **onsemi** is an Equal Opportunity/Affirmative Action Employer. This literature is subject to all applicable copyright laws and is not for resale in any manner.

## ADDITIONAL INFORMATION

### TECHNICAL PUBLICATIONS:

Technical Library: [www.onsemi.com/design/resources/technical-documentation](http://www.onsemi.com/design/resources/technical-documentation)  
onsemi Website: [www.onsemi.com](http://www.onsemi.com)

### ONLINE SUPPORT: [www.onsemi.com/support](http://www.onsemi.com/support)

For additional information, please contact your local Sales Representative at [www.onsemi.com/support/sales](http://www.onsemi.com/support/sales)

## Looking for pricing, stock, or lifecycle information?

Click below to explore more details on WIN SOURCE:

 [View NCP4371AACDR2G on WIN SOURCE](#)

 [ON Semiconductor](#) Information

## Optimize Your Supply Chain with WIN SOURCE Solutions

-  Global Sourcing Solution
-  Obsolete Management
-  Cost Control Management
-  Shortage Management
-  Alternative Solution
-  Excess Inventory Management