



**THE DATASHEET OF
TPS54618CQRTERQ1**



TPS54618C-Q1 Automotive 2.95-V to 6-V, 6-A, Synchronous Buck Converter

1 Features

- AEC-Q100 qualified for automotive applications:
 - Temperature grade 1: -40°C to +125°C, T_A
- [Functional Safety-Capable](#)
 - [Documentation available to aid functional safety system design](#)
- Two 12-mΩ (typical) MOSFETs for high efficiency at 6-A loads
- 300-kHz to 2-MHz switching frequency
- 0.8-V ±1% Voltage reference over temperature (-40°C to +150°C)
- Synchronizes to external clock
- Adjustable slow start and sequencing
- UV and OV power-good output
- New product available: [TPS62816-Q1](#), 6-V step-down converter in 2-mm x 3-mm QFN package with wettable flanks
- Thermally-enhanced 3-mm x 3-mm, 16-pin WQFN package

2 Applications

- [Automotive head unit](#)
- [Automotive instrument cluster](#)
- [Automotive ADAS camera](#)

3 Description

The TPS54618C-Q1 device is a full-featured 6-V, 6-A, synchronous step-down current-mode converter with two integrated MOSFETs.

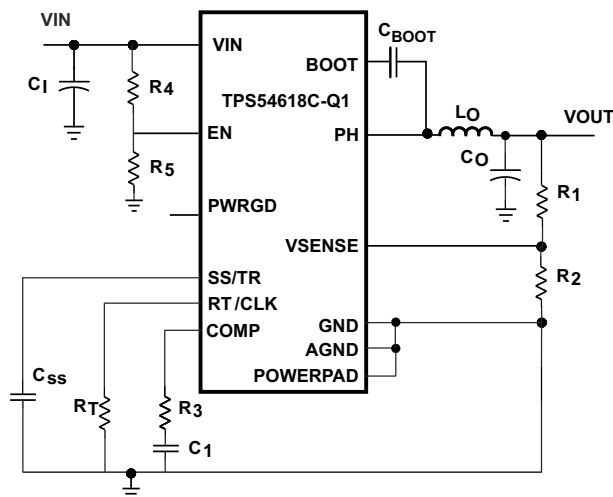

Simplified Schematic

The TPS54618C-Q1 enables small designs by integrating the MOSFETs, implementing current-mode control to reduce external component count, reducing inductor size by enabling up to 2-MHz switching frequency, and minimizing the IC footprint with a small, 3-mm x 3-mm, thermally-enhanced WQFN package.

The TPS54618C-Q1 provides accurate regulation for a variety of loads with an accurate ±1% voltage reference (VREF) over temperature.

Efficiency is maximized through the integrated 12-mΩ MOSFETs and 515-μA typical supply current. Using the enable pin, shutdown supply current is reduced to 5.5-μA by entering a shutdown mode.

Undervoltage lockout is internally set at 2.6 V, but can be increased by programming the threshold with a resistor network on the enable pin. The output-voltage start-up ramp is controlled by the slow-start pin. An open-drain power-good signal indicates the output is within 93% to 107% of its nominal voltage.

Frequency foldback and thermal shutdown protect the device during an overcurrent condition.

Device Information

PART NUMBER ⁽¹⁾	PACKAGE	BODY SIZE (NOM)
TPS54618C-Q1	WQFN (16)	3.00 mm x 3.00 mm

- (1) For all available packages, see the orderable addendum at the end of the data sheet.

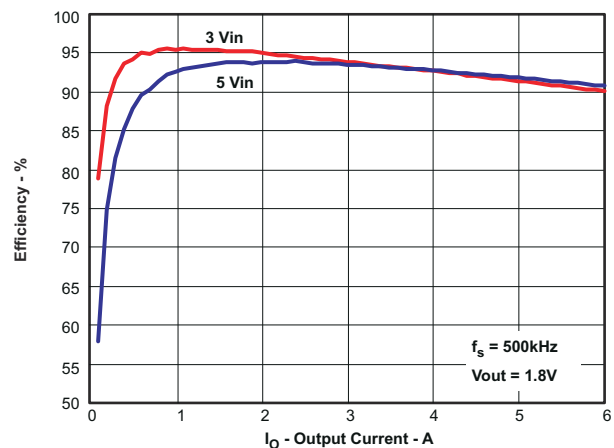

Efficiency vs Output Current



Table of Contents

1 Features	1	7.4 Device Functional Modes.....	20
2 Applications	1	8 Application and Implementation	24
3 Description	1	8.1 Application Information.....	24
4 Revision History	2	8.2 Typical Application.....	24
5 Pin Configuration and Functions	3	9 Power Supply Recommendations	32
Pin Functions.....	3	10 Layout	33
6 Specifications	5	10.1 Layout Guidelines.....	33
6.1 Absolute Maximum Ratings	5	10.2 Layout Example.....	34
6.2 ESD Ratings	5	10.3 Power Dissipation Estimate.....	34
6.3 Recommended Operating Conditions	5	11 Device and Documentation Support	36
6.4 Thermal Information	5	11.1 Device Support.....	36
6.5 Electrical Characteristics	6	11.2 Receiving Notification of Documentation Updates..	36
6.6 Timing Requirements	7	11.3 Support Resources.....	36
6.7 Typical Characteristics.....	8	11.4 Trademarks.....	36
7 Detailed Description	12	11.5 Electrostatic Discharge Caution.....	36
7.1 Overview.....	12	11.6 Glossary.....	36
7.2 Functional Block Diagram.....	13	12 Mechanical, Packaging, and Orderable	
7.3 Feature Description.....	13	Information	36

4 Revision History

NOTE: Page numbers for previous revisions may differ from page numbers in the current version.

Changes from Revision * (September 2020) to Revision A (August 2021)	Page
• Added TPS62816-Q1 promotion bullet.....	1
• Changed "Start with 100 kΩ for the R1 resistor and use equation 1..." to "Pick a suitable value for R1 and use equation 1...".....	14

5 Pin Configuration and Functions

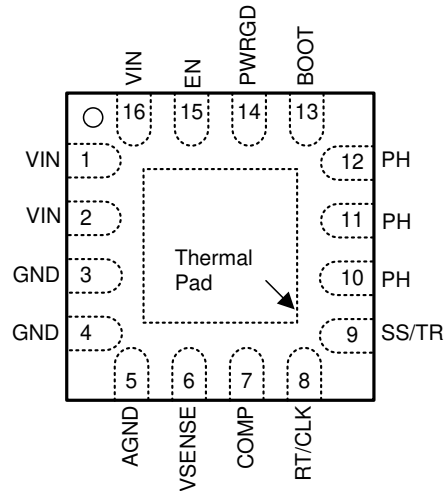

Figure 5-1. 16-Pin WQFN With Exposed Thermal Pad RTE Package (Top View)

Table 5-1. Pin Functions

PIN		TYPE ⁽¹⁾	DESCRIPTION
NAME	NO.		
AGND	5	G	Analog ground must be electrically connected to GND close to the device.
BOOT	13	I	A bootstrap capacitor is required between BOOT and PH. If the voltage on this capacitor is below the minimum required by the BOOT UVLO, the output is forced to switch off until the capacitor is refreshed.
COMP	7	O	Error amplifier output, and input to the output switch current comparator. Connect frequency compensation components to this pin.
EN	15	I	Enable pin and internal pullup current source. Pull below 1.2 V to disable. Float to enable. Can be used to set the on/off threshold (adjust UVLO) with two additional resistors.
GND	3	G	Power ground. This pin must be electrically connected directly to the power pad under the device.
	4		
PH	10	O	The source of the internal high-side power MOSFET, and drain of the internal low-side (synchronous) rectifier MOSFET.
	11		
	12		
PWRGD	14	O	An open-drain output, asserts low if output voltage is low due to thermal shutdown, overcurrent, overvoltage and undervoltage, or EN shutdown.
RT/CLK	8	I/O	Resistor timing or external clock input pin
SS/TR	9	I/O	Slow start and tracking. An external capacitor connected to this pin sets the output voltage rise time. This pin can also be used for tracking.
VIN	1	I	Input supply voltage: 2.95 V to 6 V
	2		
	16		
VSENSE	6	I	Inverting node of the transconductance (gm) error amplifier
Thermal Pad	—	G	GND pin must be connected to the exposed power pad for proper operation. This power pad must be connected to any internal PCB ground plane using multiple vias for good thermal performance.

(1) I = Input, O = Output, G = Ground

Pin Functions

PIN		TYPE ⁽¹⁾	DESCRIPTION
NAME	NO.		
AGND	5	G	Analog ground must be electrically connected to GND close to the device.

PIN		TYPE ⁽¹⁾	DESCRIPTION
NAME	NO.		
BOOT	13	I	A bootstrap capacitor is required between BOOT and PH. If the voltage on this capacitor is below the minimum required by the BOOT UVLO, the output is forced to switch off until the capacitor is refreshed.
COMP	7	O	Error amplifier output, and input to the output switch current comparator. Connect frequency compensation components to this pin.
EN	15	I	Enable pin and internal pullup current source. Pull below 1.2 V to disable. Float to enable. Can be used to set the on/off threshold (adjust UVLO) with two additional resistors.
GND	3	G	Power ground. This pin must be electrically connected directly to the power pad under the device.
	4		
PH	10	O	The source of the internal high-side power MOSFET, and drain of the internal low-side (synchronous) rectifier MOSFET.
	11		
	12		
PWRGD	14	O	An open-drain output, asserts low if output voltage is low due to thermal shutdown, overcurrent, overvoltage and undervoltage, or EN shutdown.
RT/CLK	8	I/O	Resistor timing or external clock input pin
SS/TR	9	I/O	Slow start and tracking. An external capacitor connected to this pin sets the output voltage rise time. This pin can also be used for tracking.
VIN	1	I	Input supply voltage: 2.95 V to 6 V
	2		
	16		
VSENSE	6	I	Inverting node of the transconductance (gm) error amplifier
Thermal Pad	—	G	GND pin must be connected to the exposed power pad for proper operation. This power pad must be connected to any internal PCB ground plane using multiple vias for good thermal performance.

(1) I = Input, O = Output, G = Ground

6 Specifications

6.1 Absolute Maximum Ratings

over operating free-air temperature range (unless otherwise noted)⁽¹⁾

		MIN	MAX	UNIT
Input voltage	PWRGD, VIN	-0.3	7	V
	EN, RT/CLK	-0.3	4	
	COMP, SS, VSENSE	-0.3	3	
	BOOT		V _{PH} + 7	
Output voltage	BOOT-PH		7	V
	PH	-0.6	7	
	PH (10-ns transient)	-2	10	
Source current	EN, RT/CLK		100	μA
Sink current	COMP, SS		100	μA
	PWRGD		10	mA
Operating junction temperature, T _J		-40	150	°C
Storage temperature, T _{stg}		-65	150	°C

- (1) Stresses beyond those listed under *Absolute Maximum Ratings* may cause permanent damage to the device. These are stress ratings only, which do not imply functional operation of the device at these or any other conditions beyond those indicated under [Section 6.3](#). Exposure to absolute-maximum-rated conditions for extended periods may affect device reliability.

6.2 ESD Ratings

			VALUE	UNIT
V _(ESD)	Electrostatic discharge	Human-body model (HBM), per AEC Q100-002 ⁽¹⁾ HBM ESD classification level XX	±2000	V
		Charged-device model (CDM), per AEC Q100-011 CDM ESD classification level XX	±750	

- (1) AEC Q100-002 indicates that HBM stressing shall be in accordance with the ANSI/ESDA/JEDEC JS-001 specification.

6.3 Recommended Operating Conditions

over operating free-air temperature range (unless otherwise noted)

		MIN	MAX	UNIT
V _{VIN}	Input voltage	3	6	V
T _A	Operating ambient temperature	-40	125	°C

6.4 Thermal Information

THERMAL METRIC ⁽²⁾ (1)		TPS54618C-Q1	UNIT
		RTE (WQFN)	
		16 PINS	
R _{θJA}	Junction-to-ambient thermal resistance	44.38	°C/W
R _{θJC(top)}	Junction-to-case (top) thermal resistance	46.09	°C/W
R _{θJB}	Junction-to-board thermal resistance	15.96	°C/W
ψ _{JT}	Junction-to-top characterization parameter	0.69	°C/W
ψ _{JB}	Junction-to-board characterization parameter	15.91	°C/W
R _{θJC(bot)}	Junction-to-case (bottom) thermal resistance	4.55	°C/W

- (1) For more information about traditional and new thermal metrics, see the [Semiconductor and IC Package Thermal Metrics](#) application report.
(2) Unless otherwise specified, metrics listed in this table refer to JEDEC high-K board measurements

6.5 Electrical Characteristics

 at $T_J = -40^{\circ}\text{C}$ to $+125^{\circ}\text{C}$, $V_{IN} = 2.95$ to 6 V (unless otherwise noted)

PARAMETER	TEST CONDITIONS	MIN	TYP	MAX	UNIT
SUPPLY VOLTAGE (VIN PIN)					
Operating input voltage		2.95		6	V
Internal undervoltage lockout threshold	VIN UVLO STOP		2.28	2.5	V
	VIN UVLO START		2.45	2.6	
Shutdown supply current	EN = 0 V, 25°C, 2.95 V ≤ VIN ≤ 6 V		5.5	15	μA
Quiescent current, IQ	VSENSE = 0.9 V, VIN = 5 V, 25°C, RT = 400 kΩ		515	650	μA
ENABLE AND UVLO (EN PIN)					
Enable threshold	Rising		1.25		V
	Falling		1.18		
Input current	Enable threshold + 50 mV		-3.5		μA
	Enable threshold - 50 mV		-1.9		
VOLTAGE REFERENCE (VSENSE PIN)					
Voltage reference	2.95 V ≤ VIN ≤ 6 V, -40°C < TJ < 150°C	0.791	0.799	0.807	V
MOSFET					
High-side switch resistance	BOOT-PH = 5 V		12	25	mΩ
	BOOT-PH = 2.95 V		16	33	
Low-side switch resistance	VIN = 5 V		13	25	mΩ
	VIN = 2.95 V		17	33	
ERROR AMPLIFIER					
Input current			2		nA
Error amplifier transconductance (gm)	-2 μA < ICOMP < 2 μA, VCOMP = 1 V		245		μmhos
Error amplifier transconductance (gm) during slow start	-2 μA < ICOMP < 2 μA, VCOMP = 1 V, VSENSE = 0.4 V		79		μmhos
Error amplifier source/sink	VCOMP = 1 V, 100-mV overdrive		±20		μA
COMP to Iswitch gm			25		A/V
CURRENT LIMIT					
Current limit threshold	VIN = 6 V, 25°C < TJ < 150°C	7.46	10.6	15.3	A
	VIN = 2.95 V, 25°C < TJ < 150°C	7.68	10.2	13.5	
THERMAL SHUTDOWN					
Thermal shutdown			168		°C
Hysteresis			20		°C
BOOT (BOOT PIN)					
BOOT charge resistance	VIN = 5 V		16		Ω
BOOT-PH UVLO	VIN = 2.95 V		2.1		V
SLOW-START AND TRACKING (SS/TR PIN)					
Charge current	V(SS/TR) = 0.4 V		2		μA
SS/TR to VSENSE matching	V(SS/TR) = 0.4 V		54		mV
SS/TR to reference crossover	98% normal		1.1		V
SS/TR discharge voltage (overload)	VSENSE = 0 V		61		mV
SS/TR discharge current (overload)	VSENSE = 0 V, V(SS/TR) = 0.4 V		350		μA
SS discharge current (UVLO, EN, Thermal fault)	VIN = 5 V, V(SS) = 0.5 V		1.9		mA

at $T_J = -40^\circ\text{C}$ to $+125^\circ\text{C}$, $V_{IN} = 2.95$ to 6 V (unless otherwise noted)

PARAMETER	TEST CONDITIONS	MIN	TYP	MAX	UNIT
POWER GOOD (PWRGD PIN)					
VSENSE threshold	VSENSE falling (Fault)		91%		Vre
	VSENSE rising (Good)		93%		
	VSENSE rising (Fault)		109%		
	VSENSE falling (Good)		107%		
Hysteresis	VSENSE falling		2%		Vref
Output high leakage	VSENSE = VREF, $V_{(PWRGD)} = 5.5\text{ V}$		7		nA
ON-resistance			56	100	Ω
Output low	$I_{(PWRGD)} = 3\text{ mA}$		0.2	0.3	V
Minimum V_{IN} for valid output	$V_{(PWRGD)} < 0.5\text{ V}$ at $100\ \mu\text{A}$		0.65	1.5	V

6.6 Timing Requirements

		MIN	NOM	MAX	UNIT
TIMING RESISTOR AND EXTERNAL CLOCK (RT/CLK PIN)					
Switching frequency range using RT mode		200		2000	kHz
Switching frequency	$R_t = 400\text{ k}\Omega$	400	500	600	kHz
Switching frequency range using CLK mode		300		2000	kHz
Minimum CLK pulse width		75			ns
RT/CLK voltage	$R_{(RT/CLK)} = 400\text{ k}\Omega$		0.5		V
RT/CLK high threshold			1.6	2.2	V
RT/CLK low threshold		0.4	0.6		V
RT/CLK falling edge to PH rising edge delay	Measure at 500 kHz with RT resistor in series		90		ns
PLL lock in time	Measure at 500 kHz		42		μs
PH (PH PIN)					
Minimum ON-time	Measured at 50% points on PH, $I_{OUT} = 3\text{ A}$		75		ns
	Measured at 50% points on PH, $V_{IN} = 6\text{ V}$, $I_{OUT} = 0\text{ A}$		120		
Minimum OFF-time	Prior to skipping off pulses, $BOOT\text{-}PH = 2.95\text{ V}$, $I_{OUT} = 3\text{ A}$		60		ns
Rise time	$V_{IN} = 6\text{ V}$, 6 A		2.25		V/ns
Fall time	$V_{IN} = 6\text{ V}$, 6 A		2		

6.7 Typical Characteristics

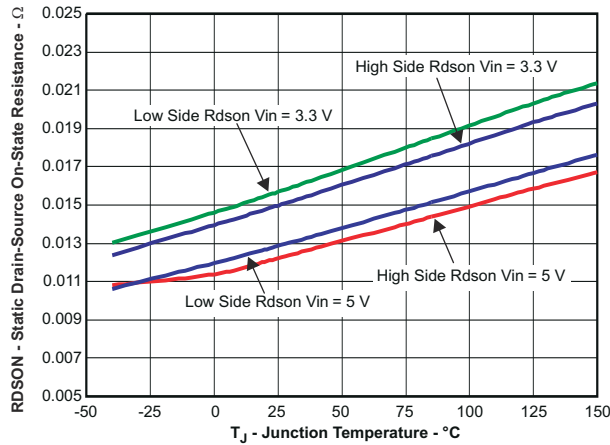

Figure 6-1. High-Side and Low-Side ON-Resistance vs Junction Temperature

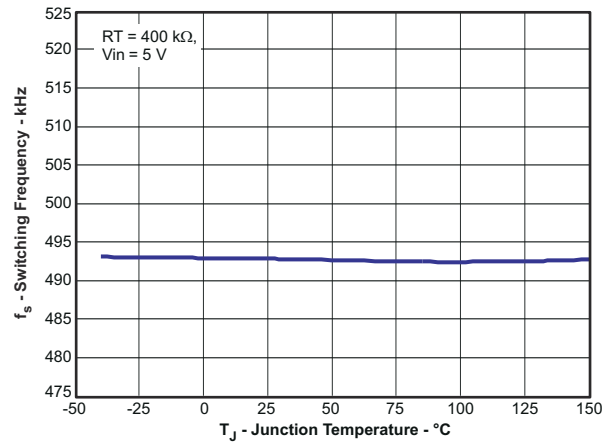

Figure 6-2. Switching Frequency vs Junction Temperature

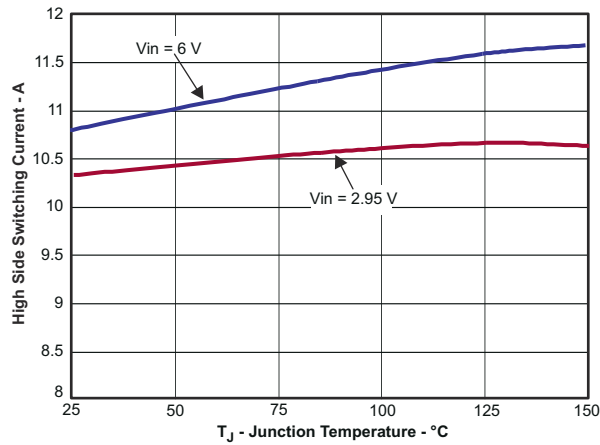

Figure 6-3. High-Side Current Limit vs Junction Temperature

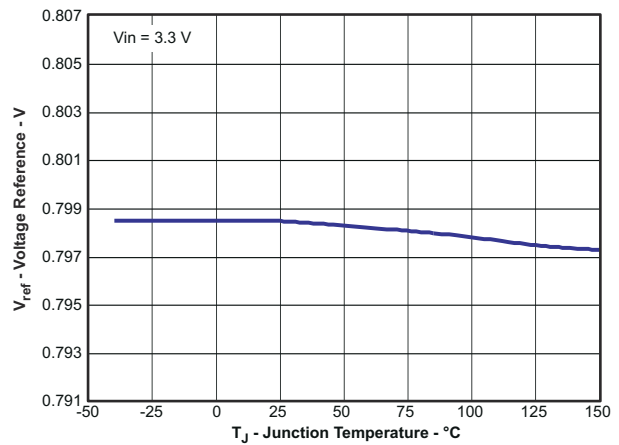

Figure 6-4. Voltage Reference vs Junction Temperature

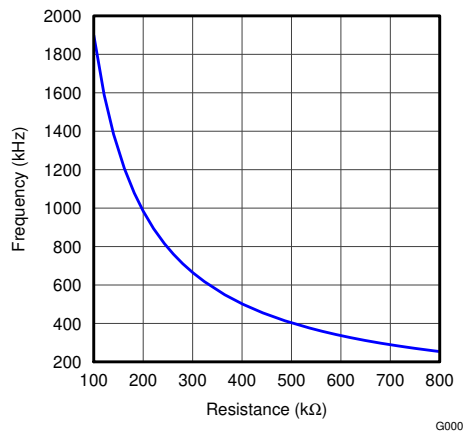

Figure 6-5. Switching Frequency vs RT Resistance Low Frequency Range

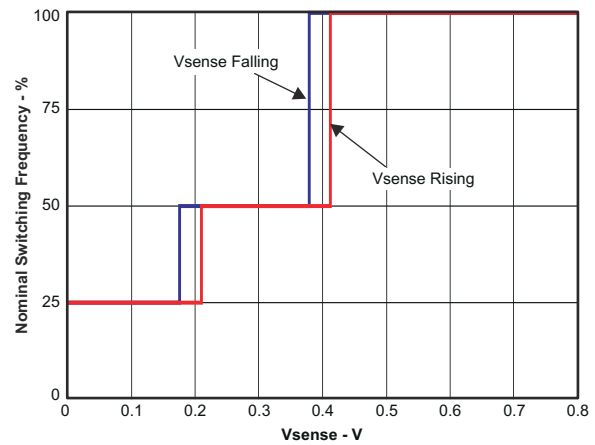

Figure 6-6. Switching Frequency vs Vsense

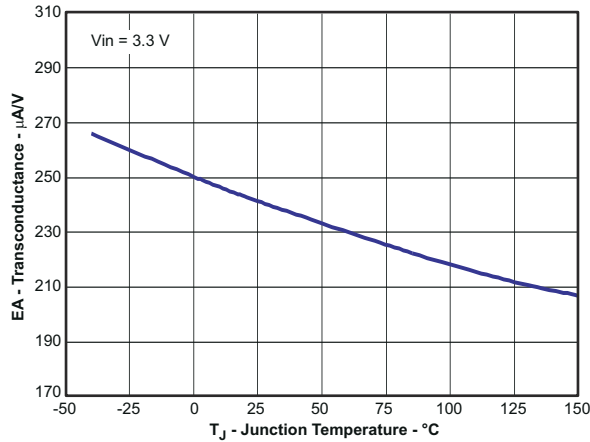

Figure 6-7. Transconductance vs Junction Temperature

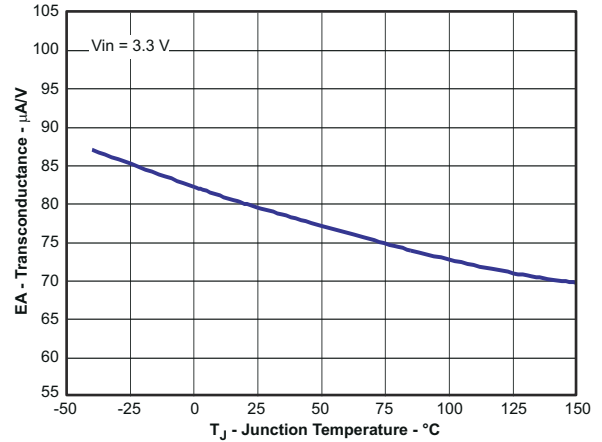

Figure 6-8. Transconductance (Soft-Start) vs Junction Temperature

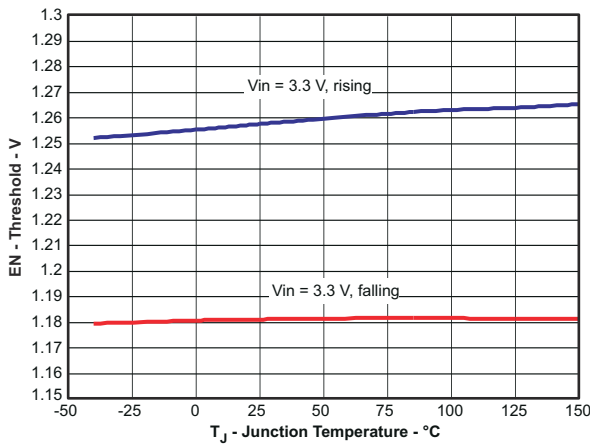

Figure 6-9. Enable Pin Voltage vs Junction Temperature

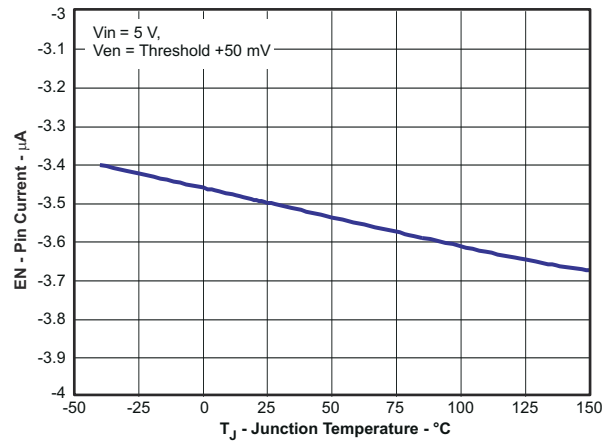

Figure 6-10. EN Pin Current vs Junction Temperature

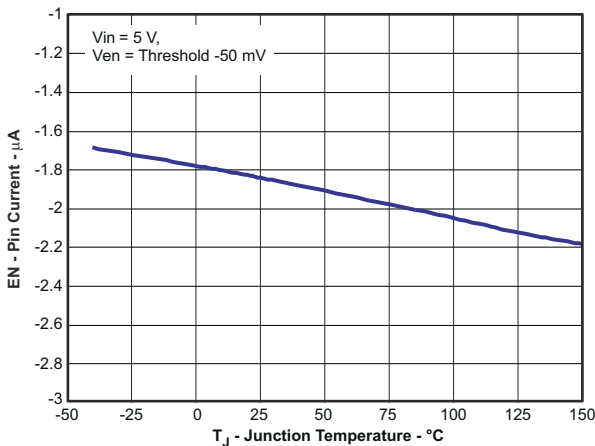

Figure 6-11. EN Pin Current vs Junction Temperature

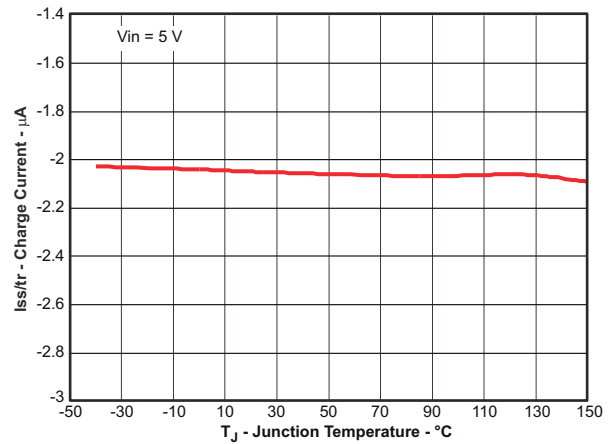

Figure 6-12. Charge Current vs Junction Temperature

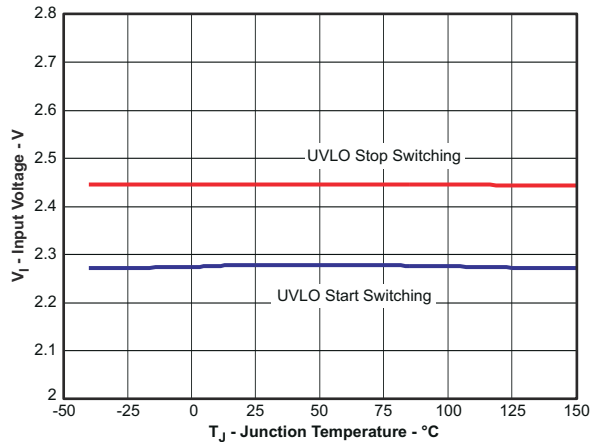

Figure 6-13. Input Voltage vs Junction Temperature

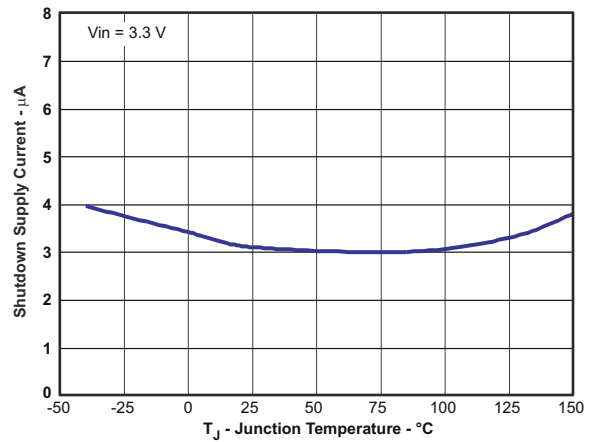

Figure 6-14. Shutdown Supply Current vs Junction Temperature

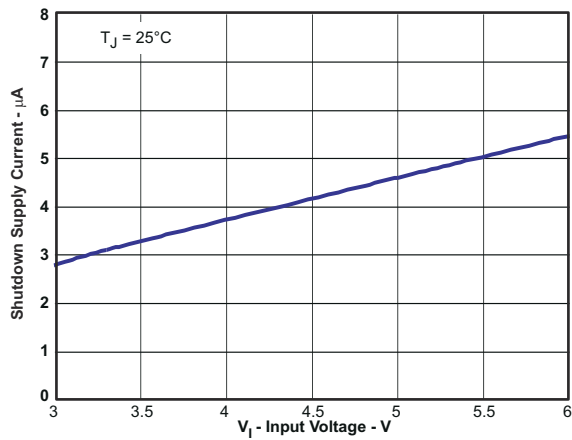

Figure 6-15. Shutdown Supply Current vs Input Voltage

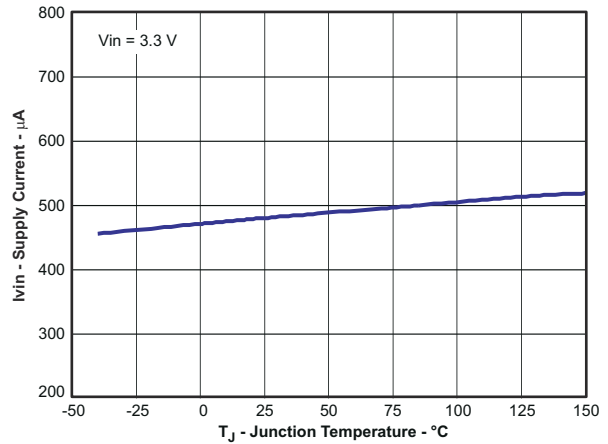

Figure 6-16. Supply Current vs Junction Temperature

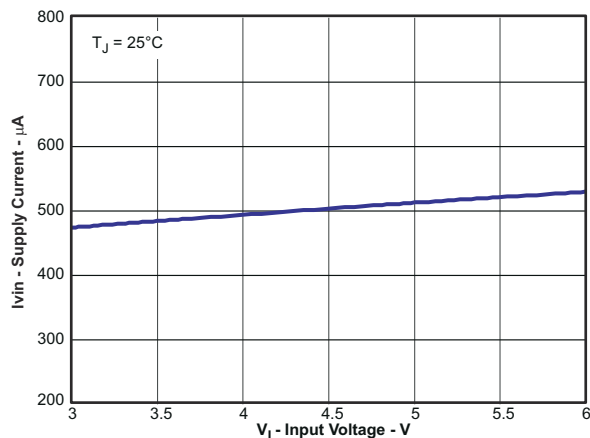

Figure 6-17. Supply Current vs Input Voltage

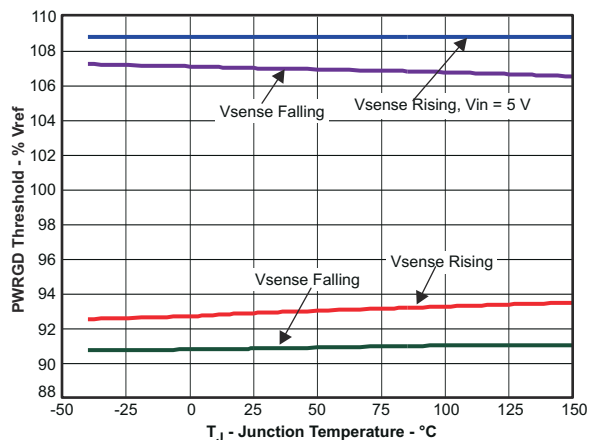

Figure 6-18. PWRGD Threshold vs Junction Temperature

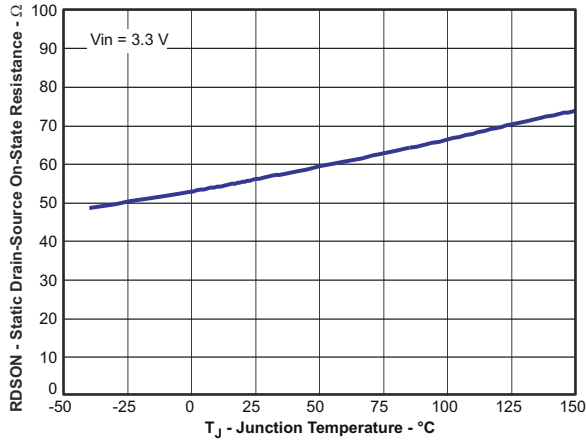

Figure 6-19. PWRGD ON-Resistance vs Junction Temperature

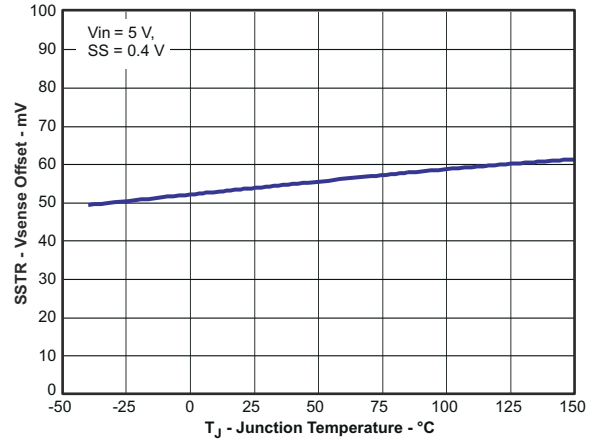

Figure 6-20. SS/TR to VSENSE Offset vs Junction Temperature

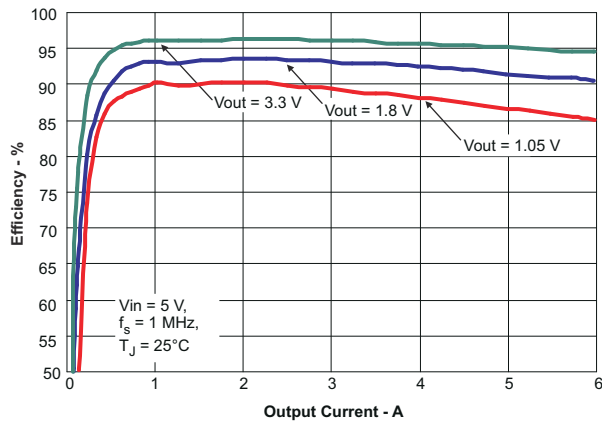

Figure 6-21. Efficiency vs Load Current

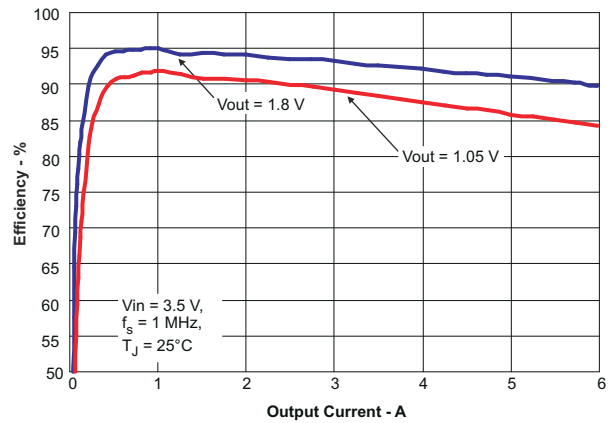

Figure 6-22. Efficiency vs Load Current

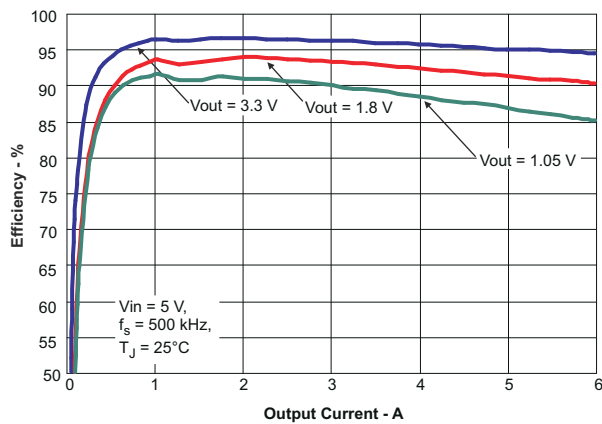

Figure 6-23. Efficiency vs Load Current

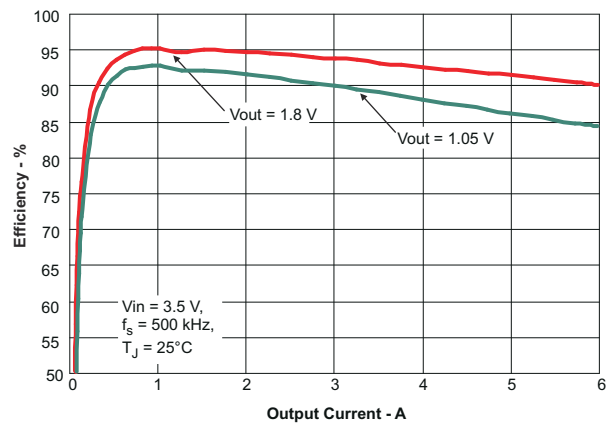

Figure 6-24. Efficiency vs Load Current

7 Detailed Description

7.1 Overview

The TPS54618C-Q1 is a 6-V, 6-A, synchronous step-down (buck) converter with two integrated n-channel MOSFETs. To improve performance during line and load transients, the device implements a constant frequency, peak current mode control which reduces output capacitance and simplifies external frequency compensation design. The wide switching frequency range of 200 kHz to 2000 kHz allows for efficiency and size optimization when selecting the output filter components. The switching frequency is adjusted using a resistor to ground on the RT/CLK pin. The device has an internal phase lock loop (PLL) on the RT/CLK pin that is used to synchronize the power switch turnon to a falling edge of an external system clock.

The TPS54618C-Q1 has a typical default start-up voltage of 2.45 V. The EN pin has an internal pullup current source that can be used to adjust the input voltage undervoltage lockout (UVLO) with two external resistors. In addition, the pullup current provides a default condition when the EN pin is floating for the device to operate. The total operating current for the TPS54618C-Q1 is typically 515 μ A when not switching and under no load. When the device is disabled, the supply current is less than 5.5 μ A.

The integrated 12-m Ω MOSFETs allow for high efficiency power supply designs with continuous output currents up to 6 A.

The TPS54618C-Q1 reduces the external component count by integrating the boot recharge diode. The bias voltage for the integrated high-side MOSFET is supplied by a capacitor between the BOOT and PH pins. The boot capacitor voltage is monitored by an UVLO circuit and turns off the high-side MOSFET when the voltage falls below a preset threshold. This BOOT circuit allows the TPS54618C-Q1 to operate approaching 100%. The output voltage can be stepped down to as low as the 0.799-V reference.

The TPS54618C-Q1 has a power-good comparator (PWRGD) with 2% hysteresis.

The TPS54618C-Q1 minimizes excessive output overvoltage transients by taking advantage of the overvoltage power-good comparator. When the regulated output voltage is greater than 109% of the nominal voltage, the overvoltage comparator is activated, and the high-side MOSFET is turned off and masked from turning on until the output voltage is lower than 107%.

The SS/TR (slow start/tracking) pin is used to minimize inrush currents or provide power supply sequencing during power up. A small value capacitor must be coupled to the pin for slow start. The SS/TR pin is discharged before the output power up to ensure a repeatable restart after an overtemperature fault, UVLO fault, or disabled condition.

The use of a frequency foldback circuit reduces the switching frequency during start-up and over current fault conditions to help limit the inductor current.

7.2 Functional Block Diagram

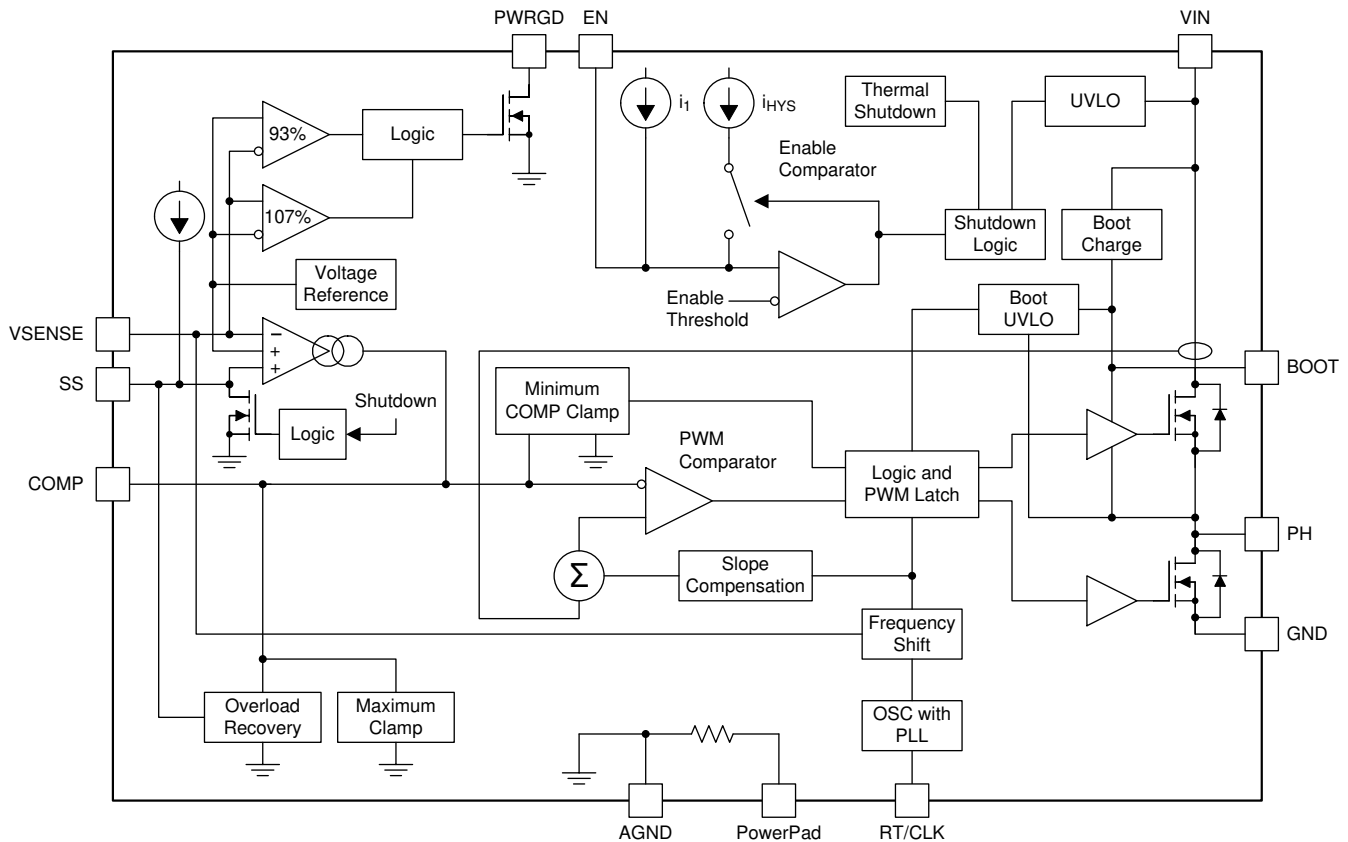

7.3 Feature Description

7.3.1 Fixed Frequency PWM Control

The TPS54618C-Q1 uses an adjustable, fixed frequency, peak current mode control. The output voltage is compared through external resistors on the VSENSE pin to an internal voltage reference by an error amplifier which drives the COMP pin. An internal oscillator initiates the turnon of the high-side power switch. The error amplifier output is compared to the high-side power switch current. When the power switch current reaches the COMP voltage level, the high-side power switch is turned off and the low-side power switch is turned on. The COMP pin voltage increases and decreases as the output current increases and decreases. The device implements a current limit by clamping the COMP pin voltage to a maximum level and also implements a minimum clamp for improved transient response performance.

7.3.2 Slope Compensation and Output Current

The TPS54618C-Q1 adds a compensating ramp to the switch current signal. This slope compensation prevents subharmonic oscillations as duty cycle increases. The available peak inductor current remains constant over the full duty cycle range.

7.3.3 Bootstrap Voltage (Boot) and Low Dropout Operation

The TPS54618C-Q1 has an integrated boot regulator and requires a small ceramic capacitor between the BOOT and PH pin to provide the gate drive voltage for the high-side MOSFET. The value of the ceramic capacitor must be 0.1 μF . A ceramic capacitor with an X7R or X5R grade dielectric with a voltage rating of 10 V or higher is recommended because of the stable characteristics over temperature and voltage.

To improve dropout, the TPS54618C-Q1 is designed to operate at 100% duty cycle as long as the BOOT-to-PH pin voltage is greater than 2.2 V. The high-side MOSFET is turned off using a UVLO circuit, allowing for the low-side MOSFET to conduct when the voltage from BOOT to PH drops below 2.2 V. Because the supply

current sourced from the BOOT pin is very low, the high-side MOSFET can remain on for more switching cycles than are required to refresh the capacitor, thus the effective duty cycle of the switching regulator is very high.

7.3.4 Error Amplifier

The TPS54618C-Q1 has a transconductance amplifier. The error amplifier compares the VSENSE voltage to the lower of the SS/TR pin voltage or the internal 0.799-V voltage reference. The transconductance of the error amplifier is 245 $\mu\text{A/V}$ during normal operation. When the voltage of VSENSE pin is below 0.799 V and the device is regulating using the SS/TR voltage, the gm is typically greater than 79 $\mu\text{A/V}$, but less than 245 $\mu\text{A/V}$. The frequency compensation components are placed between the COMP pin and ground.

7.3.5 Voltage Reference

The voltage reference system produces a precise $\pm 1\%$ voltage reference over temperature by scaling the output of a temperature-stable bandgap circuit. The bandgap and scaling circuits produce 0.799 V at the noninverting input of the error amplifier.

7.3.6 Adjusting the Output Voltage

The output voltage is set with a resistor divider from the output node to the VSENSE pin. TI recommends using divider resistors with 1% tolerance or better. Pick a suitable value for the R1 resistor and use [Equation 1](#) to calculate R2. To improve efficiency at very light loads, consider using larger value resistors. If the values are too high, the regulator is more susceptible to noise and voltage errors from the VSENSE input current are noticeable.

$$R2 = R1 \times \left(\frac{0.799 \text{ V}}{V_O - 0.799 \text{ V}} \right) \quad (1)$$

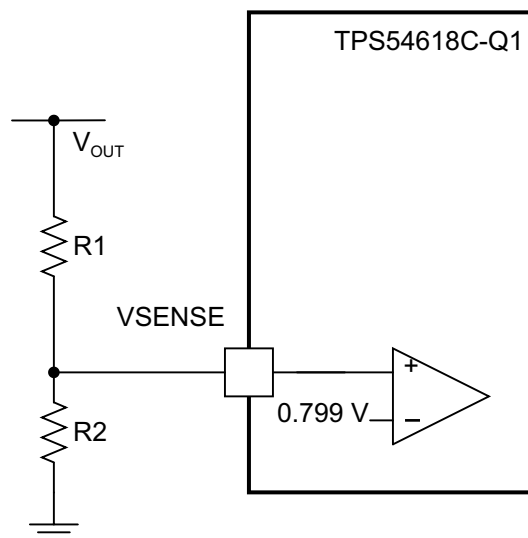

Figure 7-1. Voltage Divider Circuit

7.3.7 Enable and Adjusting Undervoltage Lockout

The TPS54618C-Q1 is disabled when the VIN pin voltage falls below 2.28 V. If an application requires a higher undervoltage lockout (UVLO), use the EN pin as shown in [Figure 7-2](#) to adjust the input voltage UVLO by using two external resistors. TI recommends using the EN resistors to set the UVLO falling threshold (V_{STOP}) above 2.6 V. The rising threshold (V_{START}) must be set to provide enough hysteresis to allow for any input supply variations. The EN pin has an internal pullup current source that provides the default condition of the TPS54618C-Q1 operating when the EN pin floats. Once the EN pin voltage exceeds 1.25 V, an additional 1.6 μA of hysteresis is added. When the EN pin is pulled below 1.18 V, the 1.6 μA is removed. This additional current facilitates input voltage hysteresis.

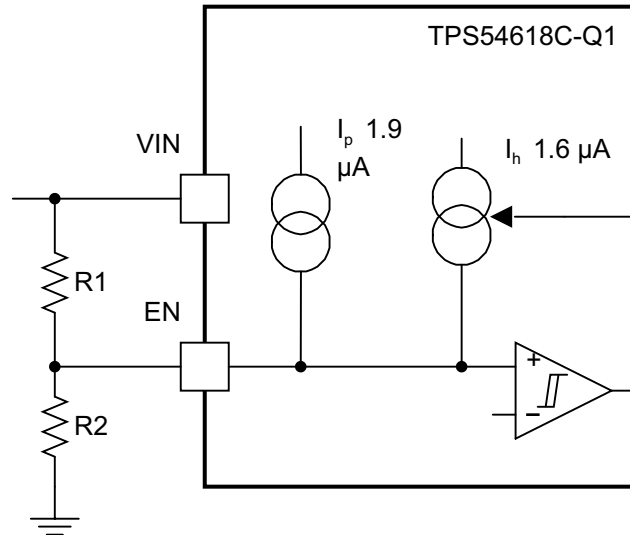

Figure 7-2. Adjustable Undervoltage Lockout

$$R1 = \frac{V_{START} \left(\frac{V_{ENFALLING}}{V_{ENRISING}} \right) - V_{STOP}}{I_p \left(1 - \frac{V_{ENFALLING}}{V_{ENRISING}} \right) + I_h} \quad (2)$$

$$R2 = \frac{R1 \times V_{ENFALLING}}{V_{STOP} - V_{ENFALLING} + R1(I_p + I_h)} \quad (3)$$

where

- R1 and R2 are in Ω
- $I_h = 1.6 \mu A$
- $I_p = 1.9 \mu A$
- $V_{ENRISING} = 1.25 V$
- $V_{ENFALLING} = 1.18 V$

7.3.8 Soft-Start Pin

The TPS54618C-Q1 regulates to the lower of the SS/TR pin and the internal reference voltage. A capacitor on the SS/TR pin to ground implements a slow-start time. The TPS54618C-Q1 has an internal pullup current source of $2 \mu A$, which charges the external slow-start capacitor. Equation 4 calculates the required slow-start capacitor value.

$$C_{ss}(nF) = \frac{T_{ss}(mS) \times I_{ss}(\mu A)}{V_{ref}(V)} \quad (4)$$

where

- T_{ss} is the desired slow-start time in ms
- I_{ss} is the internal slow-start charging current of $2 \mu A$
- V_{ref} is the internal voltage reference of $0.799 V$

If, during normal operation, the VIN goes below UVLO, the EN pin pulls below $1.2 V$, or a thermal shutdown event occurs, the TPS54618C-Q1 stops switching. When the VIN goes above UVLO, EN is released or pulled

high, or a thermal shutdown is exited, then SS/TR is discharged to below 40 mV before reinitiating a powering-up sequence. The VSENSE voltage follows the SS/TR pin voltage with a 54-mV offset up to 85% of the internal voltage reference. When the SS/TR voltage is greater than 85% on the internal reference voltage, the offset increases as the effective system reference transitions from the SS/TR voltage to the internal voltage reference.

7.3.9 Sequencing

Many of the common power supply sequencing methods can be implemented using the SS/TR, EN, and PWRGD pins. The sequential method can be implemented using an open-drain or collector output of a power-on reset pin of another device. [Figure 7-3](#) shows the sequential method. The power good is coupled to the EN pin on the TPS54618C-Q1 which enables the second power supply once the primary supply reaches regulation.

Ratio-metric start-up can be accomplished by connecting the SS/TR pins together. The regulator outputs ramp up and reach regulation at the same time. When calculating the slow-start time, the pullup current source must be doubled in [Equation 4](#). The ratio-metric method is shown in [Figure 7-5](#).

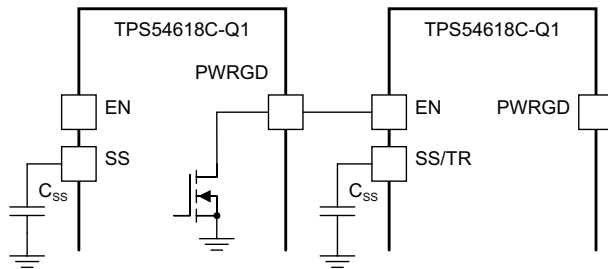

Figure 7-3. Sequential Start-Up Sequence

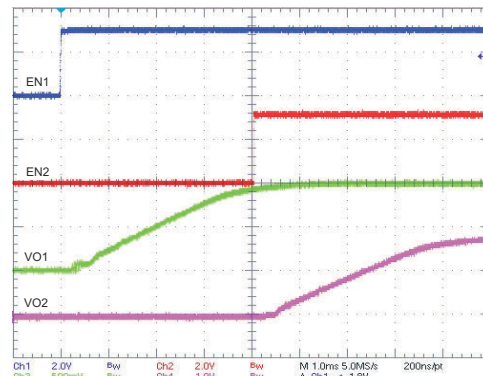

Figure 7-4. Sequential Start-Up Using EN and PWRGD

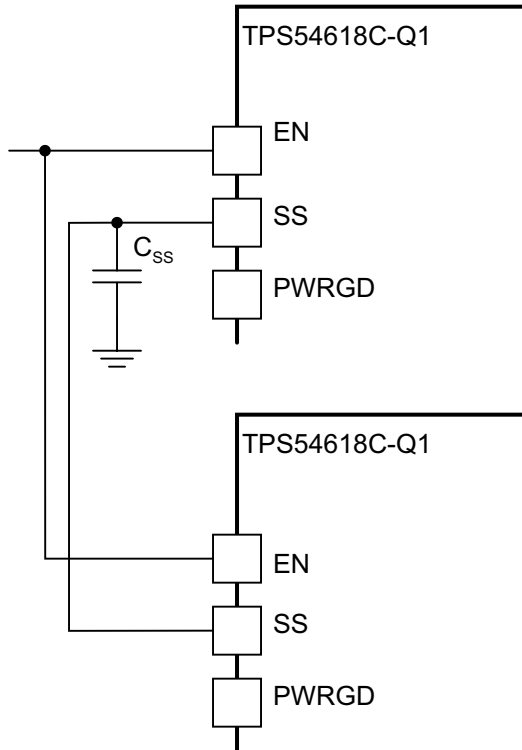

Figure 7-5. Schematic for Ratio-Metric Start-Up Sequence

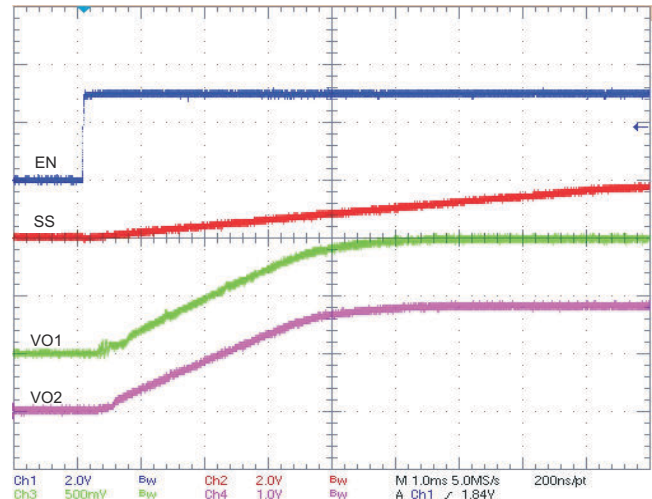

Figure 7-6. Ratio-Metric Start-Up

Ratio-metric and simultaneous power supply sequencing can be implemented by connecting the resistor network of R1 and R2 shown in Figure 7-7 to the output of the power supply that needs to be tracked or another voltage reference source. Using Equation 5 and Equation 6, the tracking resistors can be calculated to initiate the Vout2 slightly before, after, or at the same time as Vout1. Equation 7 is the voltage difference between Vout1 and Vout2. The ΔV variable is zero volts for simultaneous sequencing. To minimize the effect of the inherent SS/TR to VSENSE offset ($V_{ssoffset}$) in the slow-start circuit and the offset created by the pullup current source (I_{ss}) and tracking resistors, the $V_{ssoffset}$ and I_{ss} are included as variables in the equations. To design a ratio-metric start-up in which the Vout2 voltage is slightly greater than the Vout1 voltage when Vout2 reaches regulation, use a negative number in Equation 5 through Equation 7 for ΔV . Equation 7 results in a positive number for applications which the Vout2 is slightly lower than Vout1 when Vout2 regulation is achieved. Because the SS/TR pin must be pulled below 40 mV before starting after an EN, UVLO, or thermal shutdown fault, careful selection of the tracking resistors is needed to ensure the device restarts after a fault. Make sure the calculated R1 value from Equation 5 is greater than the value calculated in Equation 8 to ensure the device can recover from a fault. As the SS/TR voltage becomes more than 85% of the nominal reference voltage the $V_{ssoffset}$ becomes larger as the slow-start circuits gradually handoff the regulation reference to the internal voltage reference. The SS/TR pin voltage needs to be greater than 1.1 V for a complete hand off to the internal voltage reference as shown in Figure 7-6.

$$R1 = \frac{V_{out2} + \Delta V}{V_{ref}} \times \frac{V_{ssoffset}}{I_{ss}} \tag{5}$$

$$R2 = \frac{V_{ref} \times R1}{V_{out2} + \Delta V - V_{ref}} \tag{6}$$

$$\Delta V = V_{out1} - V_{out2} \tag{7}$$

$$R1 > 2930 \times V_{out1} - 145 \times \Delta V \tag{8}$$

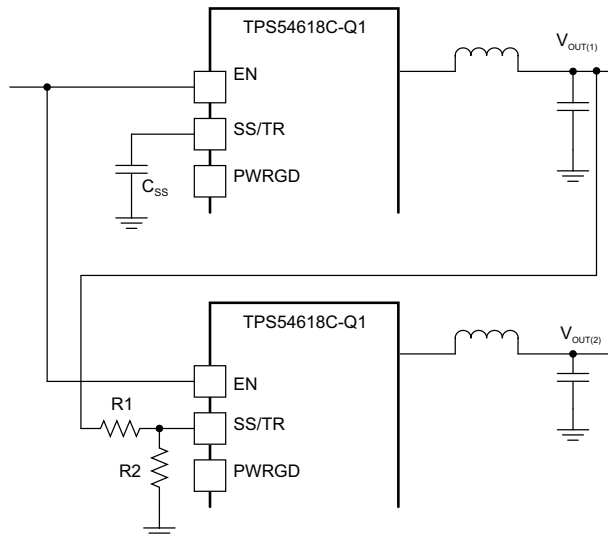

Figure 7-7. Ratio-Metric and Simultaneous Start-Up Sequence

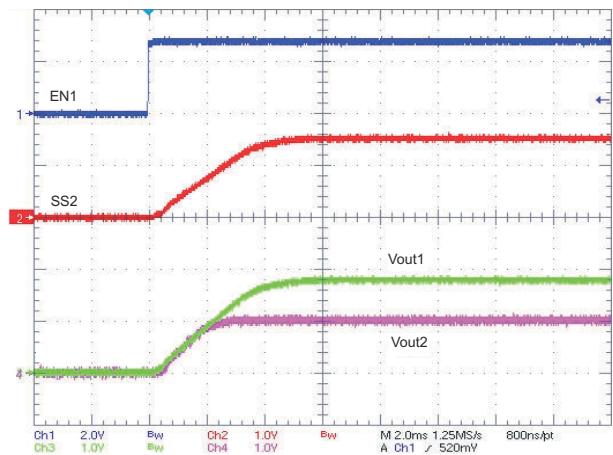

Figure 7-8. Ratio-Metric Start-Up Using Coupled SS/TR Pins

7.3.10 Constant Switching Frequency and Timing Resistor (RT/CLK Pin)

The switching frequency of the TPS54618C-Q1 is adjustable over a wide range from 300 kHz to 2000 kHz by placing a maximum of 700 kΩ and minimum of 85 kΩ, respectively, on the RT/CLK pin. An internal amplifier holds this pin at a fixed voltage when using an external resistor to ground to set the switching frequency. The RT/CLK is typically 0.5 V. To determine the timing resistance for a given switching frequency, use the curve in Equation 9 or Equation 10.

$$RT(k\Omega) = \frac{235892}{f_{sw}(kHz)^{1.027}} \tag{9}$$

$$f_{\text{SW}} \text{ (kHz)} = \frac{171032}{RT(\text{k}\Omega)^{0.974}} \quad (10)$$

To reduce the solution size, you would typically set the switching frequency as high as possible, but tradeoffs of the efficiency, maximum input voltage, and minimum controllable ON-time must be considered.

The minimum controllable ON-time is typically 75 ns at full current load and 120 ns at no load, and limits the maximum operating input voltage or output voltage.

7.3.11 Overcurrent Protection

The TPS54618C-Q1 implements a cycle-by-cycle current limit. During each switching cycle, the high-side switch current is compared to the voltage on the COMP pin. When the instantaneous switch current intersects the COMP voltage, the high-side switch is turned off. During overcurrent conditions that pull the output voltage low, the error amplifier responds by driving the COMP pin high, increasing the switch current. The error amplifier output is clamped internally. This clamp functions as a switch current limit.

7.3.12 Frequency Shift

To operate at high switching frequencies and provide protection during overcurrent conditions, the TPS54618C-Q1 implements a frequency shift. If frequency shift was not implemented during an overcurrent condition, the low-side MOSFET may not be turned off long enough to reduce the current in the inductor, causing a current runaway. With frequency shift during an overcurrent condition, the switching frequency is reduced from 100%, then 50%, then 25%, as the voltage decreases from 0.799 to 0 V on VSENSE pin to allow the low-side MOSFET to be off long enough to decrease the current in the inductor. During start-up, the switching frequency increases as the voltage on VSENSE increases from 0 to 0.799 V.

7.3.13 Reverse Overcurrent Protection

The TPS54618C-Q1 implements low-side current protection by detecting the voltage across the low-side MOSFET. When the converter sinks current through its low-side FET, the control circuit turns off the low-side MOSFET if the reverse current is typically more than 4.5 A. By implementing this additional protection scheme, the converter is able to protect itself from excessive current during power cycling and start-up into prebiased outputs.

7.3.14 Synchronize Using the RT/CLK Pin

The RT/CLK pin is used to synchronize the converter to an external system clock. See [Figure 7-9](#). To implement the synchronization feature in a system, connect a square wave to the RT/CLK pin with an ON-time of at least 75 ns. If the pin is pulled above the PLL upper threshold, a mode change occurs and the pin becomes a synchronization input. The internal amplifier is disabled and the pin is a high impedance clock input to the internal PLL. If clocking edges stop, the internal amplifier is re-enabled and the mode returns to the frequency set by the resistor. The square wave amplitude at this pin must transition lower than 0.6 V and higher than 1.6 V typically. The synchronization frequency range is 300 kHz to 2000 kHz. The rising edge of the PH is synchronized to the falling edge of RT/CLK pin.

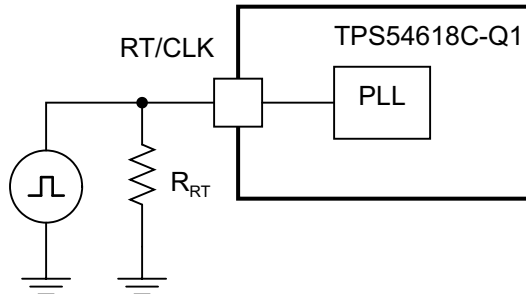

Figure 7-9. Synchronizing to a System Clock

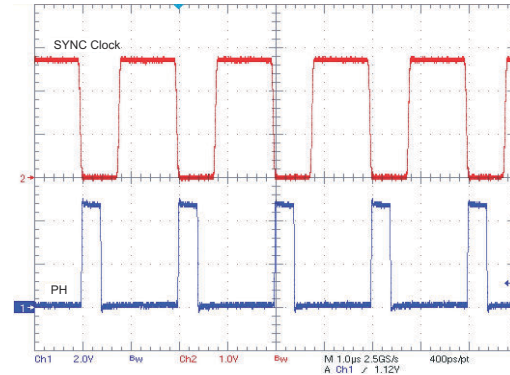

Figure 7-10. Plot of Synchronizing to System Clock

7.3.15 Power Good (PWRGD Pin)

The PWRGD pin output is an open-drain MOSFET. The output is pulled low when the VSENSE voltage enters the fault condition by falling below 91% or rising above 109% of the nominal internal reference voltage. There is a 2% hysteresis on the threshold voltage, so when the VSENSE voltage rises to the good condition above 93% or falls below 107% of the internal voltage reference, the PWRGD output MOSFET is turned off. TI recommends using a pullup resistor between the values of 1 k Ω and 100 k Ω to a voltage source that is 6 V or less. The PWRGD is in a valid state once the VIN input voltage is greater than 1.5 V.

7.3.16 Overvoltage Transient Protection

The TPS54618C-Q1 incorporates an overvoltage transient protection (OVTP) circuit to minimize voltage overshoot when recovering from output fault conditions or strong unload transients. The OVTP feature minimizes the output overshoot by implementing a circuit to compare the VSENSE pin voltage to the OVTP threshold which is 109% of the internal voltage reference. If the VSENSE pin voltage is greater than the OVTP threshold, the high-side MOSFET is disabled, preventing current from flowing to the output and minimizing output overshoot. When the VSENSE voltage drops lower than the OVTP threshold, the high-side MOSFET is allowed to turn on the next clock cycle.

7.3.17 Thermal Shutdown

The device implements an internal thermal shutdown to protect itself if the junction temperature exceeds 168°C. The thermal shutdown forces the device to stop switching when the junction temperature exceeds the thermal trip threshold. Once the die temperature decreases below 150°C, the device reinitiates the power-up sequence by discharging the SS pin to below 40 mV. The thermal shutdown hysteresis is 20°C.

7.4 Device Functional Modes

7.4.1 Simple Small Signal Model for Peak Current Mode Control

Figure 7-11 shows an equivalent model for the TPS54618C-Q1 control loop which can be modeled in a circuit simulation program to check frequency response and dynamic load response. The error amplifier is a transconductance amplifier with a gm of 245 $\mu\text{A/V}$. The error amplifier can be modeled using an ideal voltage controlled current source. The resistor R0 and capacitor Co model the open loop gain and frequency response of the amplifier. The 1-mV AC voltage source between the nodes a and b effectively breaks the control loop for the frequency response measurements. Plotting a/c shows the small signal response of the frequency compensation. Plotting a/b shows the small signal response of the overall loop. The dynamic loop response can be checked by replacing the R_L with a current source with the appropriate load step amplitude and step rate in a time domain analysis.

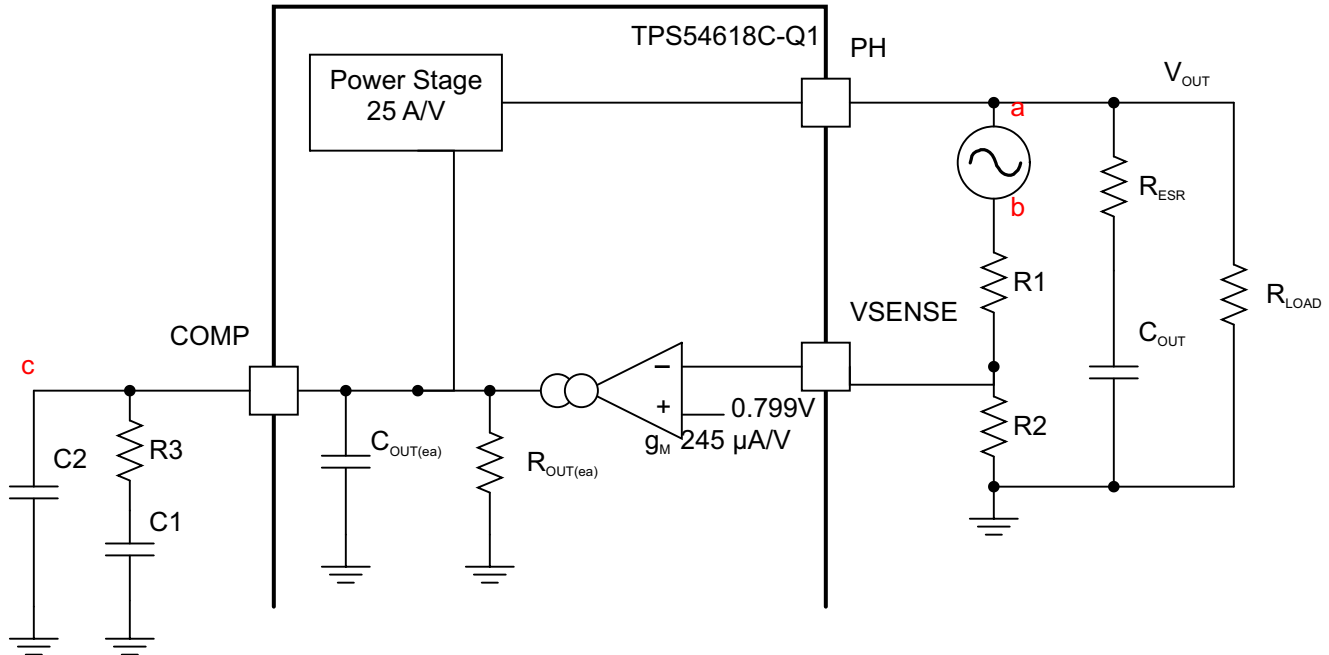
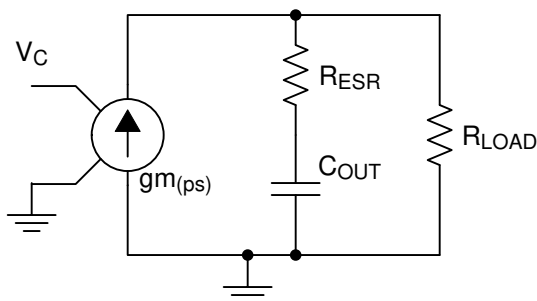

Figure 7-11. Small Signal Model for Loop Response

Figure 7-11 is a simple, small-signal model that can be used to understand how to design the frequency compensation. The TPS54618C-Q1 power stage can be approximated to a voltage-controlled current source (duty cycle modulator) supplying current to the output capacitor and load resistor. The control to output transfer function is shown in Equation 11 and consists of a DC gain, one dominant pole, and one ESR zero. The quotient of the change in switch current and the change in COMP pin voltage (node c in Figure 7-11) is the power stage transconductance. The g_m for the TPS54618C-Q1 is 25 A/V. The low frequency gain of the power stage frequency response is the product of the transconductance and the load resistance as shown in Equation 12. As the load current increases and decreases, the low frequency gain decreases and increases, respectively. This variation with load can seem problematic at first glance, but the dominant pole moves with load current. The combined effect is highlighted by the dashed line in the right half of Figure 7-13. As the load current decreases, the gain increases and the pole frequency lowers, keeping the 0-dB crossover frequency the same for the varying load conditions which makes it easier to design the frequency compensation.



Copyright © 2016, Texas Instruments Incorporated

Figure 7-12. Small Signal Model for Peak Current Mode Control

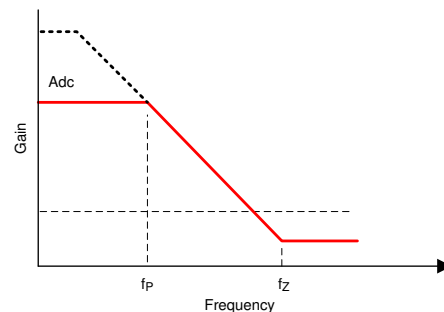

Figure 7-13. Frequency Response Model for Peak Current Mode Control

$$\frac{V_O}{V_C} = A_{dc} \times \frac{\left(1 + \frac{s}{2\pi \times fz}\right)}{\left(1 + \frac{s}{2\pi \times fp}\right)} \quad (11)$$

$$A_{dc} = g_{m_{ps}} \times R_L \quad (12)$$

$$fp = \frac{1}{C_{OUT} \times R_L \times 2\pi} \quad (13)$$

$$fz = \frac{1}{C_{OUT} \times R_{ESR} \times 2\pi} \quad (14)$$

7.4.2 Small Signal Model for Frequency Compensation

The TPS54618C-Q1 uses a transconductance amplifier for the error amplifier and readily supports two of the commonly used frequency compensation circuits. The compensation circuits are shown in Figure 7-14. The Type-2 circuits are most likely implemented in high-bandwidth power supply designs using low-ESR output capacitors. In Type 2A, one additional high-frequency pole is added to attenuate high-frequency noise.

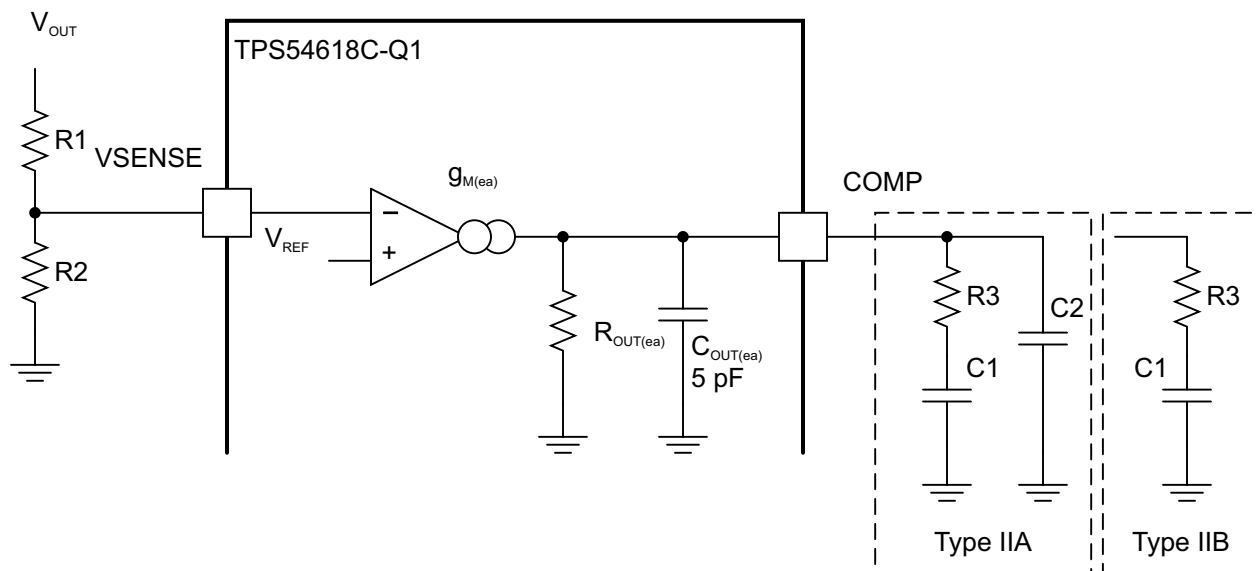

Figure 7-14. Types of Frequency Compensation

The design guidelines for TPS54618C-Q1 loop compensation are as follows:

1. The modulator pole, $f_{p\text{ mod}}$, and the esr zero, f_{z1} , must be calculated using [Equation 15](#) and [Equation 16](#). Derating the output capacitor (C_{OUT}) can be needed if the output voltage is a high percentage of the capacitor rating. Use the capacitor manufacturer information to derate the capacitor value. Use [Equation 17](#) and [Equation 18](#) to estimate a starting point for the crossover frequency, f_c . [Equation 17](#) is the geometric mean of the modulator pole and the esr zero and [Equation 18](#) is the mean of modulator pole and the switching frequency. Use the lower value of [Equation 17](#) or [Equation 18](#) as the maximum crossover frequency.

$$f_{p\text{ mod}} = \frac{I_{out\max}}{2\pi \times V_{out} \times C_{out}} \quad (15)$$

$$f_{z\text{ mod}} = \frac{1}{2\pi \times R_{esr} \times C_{out}} \quad (16)$$

$$f_c = \sqrt{f_{p\text{ mod}} \times f_{z\text{ mod}}} \quad (17)$$

$$f_c = \sqrt{f_{p\text{ mod}} \times \frac{f_{sw}}{2}} \quad (18)$$

2. R_3 can be determined by [Equation 19](#):

$$R_3 = \frac{2\pi \times f_c \times V_o \times C_{OUT}}{g_{m_{ea}} \times V_{ref} \times g_{m_{ps}}} \quad (19)$$

where

- the $g_{m_{ea}}$ amplifier gain (245 $\mu\text{A/V}$)
- $g_{m_{ps}}$ is the power stage gain (25 A/V)

3. Place a compensation zero at the dominant pole:

$$f_p = \frac{1}{C_{OUT} \times R_L \times 2\pi}$$

C_1 can be determined by [Equation 20](#):

$$C_1 = \frac{R_L \times C_{OUT}}{R_3} \quad (20)$$

4. C_2 is optional. It can be used to cancel the zero from the ESR of C_{OUT} .

$$C_2 = \frac{R_{esr} \times C_{OUT}}{R_3} \quad (21)$$

8 Application and Implementation

Note

Information in the following applications sections is not part of the TI component specification, and TI does not warrant its accuracy or completeness. TI's customers are responsible for determining suitability of components for their purposes. Customers should validate and test their design implementation to confirm system functionality.

8.1 Application Information

This design example describes a high-frequency switching regulator design using ceramic output capacitors. This design is available as the [HPA606](#) evaluation module (EVM).

8.2 Typical Application

This section details a high-frequency, 1.8-V output power supply design application with adjusted UVLO.

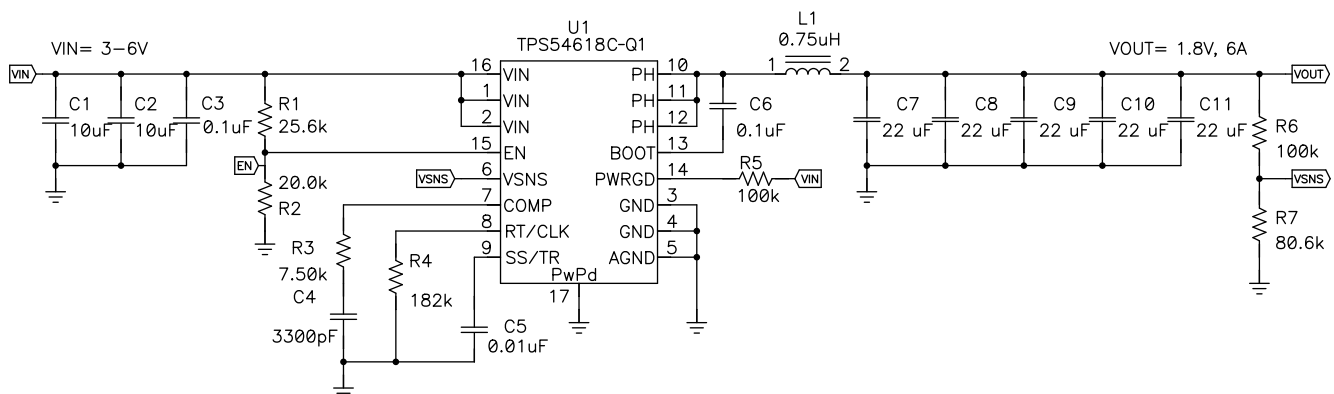

Figure 8-1. Typical Application Schematic TPS54618C-Q1

8.2.1 Design Requirements

The design parameters for the TPS54618C-Q1 are listed in [Table 8-1](#).

Table 8-1. Design Parameters

PARAMETER	CONDITIONS	MIN	TYP	MAX	UNIT
V_{IN}	Input voltage	3	3.3	6	V
V_{OUT}	Output voltage		1.8		V
ΔV_{OUT}	Transient response	1.5-A to 4.5-A load step	4%		
$I_{OUT(max)}$	Maximum output current			6	A
$V_{OUT(ripple)}$	Output voltage ripple			30	mV _{P-P}
f_{SW}	Switching frequency		1000		kHz

8.2.2 Detailed Design Procedure

8.2.2.1 Step One: Select the Switching Frequency

The first step is to decide on a switching frequency for the regulator. Typically, you want to choose the highest switching frequency possible because this produces the smallest solution size. The high-switching frequency allows for lower valued inductors and smaller output capacitors compared to a power supply that switches at a lower frequency. However, the highest switching frequency causes extra switching losses, which hurt the performance of the converter. The converter is capable of running from 300 kHz to 2 MHz. Unless a small solution size is an ultimate goal, a moderate switching frequency of 1 MHz is selected to achieve both a small solution size and a high-efficiency operation. Using [Equation 9](#), R4 is calculated to be 180 k Ω . A standard 1% 182-k Ω value was chosen in the design.

8.2.2.2 Step Two: Select the Output Inductor

The inductor selected works for the entire TPS54618C-Q1 input voltage range. To calculate the value of the output inductor, use Equation 22. K_{IND} is a coefficient that represents the amount of inductor ripple current relative to the maximum output current. The inductor ripple current is filtered by the output capacitor. Therefore, choosing high inductor ripple currents impacts the selection of the output capacitor because the output capacitor must have a ripple current rating equal to or greater than the inductor ripple current. In general, the inductor ripple value is at the discretion of the designer; however, K_{IND} is normally from 0.1 to 0.3 for the majority of applications.

For this design example, use $K_{IND} = 0.3$ and the inductor value is calculated to be 0.7 μH . For this design, a nearest standard value was chosen: 0.75 μH . For the output filter inductor, it is important that the RMS current and saturation current ratings not be exceeded. The RMS and peak inductor current can be found from Equation 24 and Equation 25.

For this design, the RMS inductor current is 6.01 A and the peak inductor current is 6.84 A. The chosen inductor is a Toko FDV0630-R75M. It has a saturation current rating of 10 A and a RMS current rating of 8.9 A.

The current flowing through the inductor is the inductor ripple current plus the output current. During power up, faults, or transient load conditions, the inductor current can increase above the calculated peak inductor current level calculated above. In transient conditions, the inductor current can increase up to the switch current limit of the device. For this reason, the most conservative approach is to specify an inductor with a saturation current rating equal to or greater than the switch current limit rather than the peak inductor current.

$$L1 = \frac{V_{inmax} - V_{out}}{I_o \times K_{ind}} \times \frac{V_{out}}{V_{inmax} \times f_{sw}} \quad (22)$$

$$I_{ripple} = \frac{V_{inmax} - V_{out}}{L1} \times \frac{V_{out}}{V_{inmax} \times f_{sw}} \quad (23)$$

$$I_{Lrms} = \sqrt{I_o^2 + \frac{1}{12} \times \left(\frac{V_o \times (V_{inmax} - V_o)}{V_{inmax} \times L1 \times f_{sw}} \right)^2} \quad (24)$$

$$I_{Lpeak} = I_{out} + \frac{I_{ripple}}{2} \quad (25)$$

8.2.2.3 Step Three: Choose the Output Capacitor

There are three primary considerations for selecting the value of the output capacitor. The output capacitor determines the modulator pole, the output voltage ripple, and how the regulator responds to a large change in load current. The output capacitance needs to be selected based on the more stringent of these three criteria.

The desired response to a large change in the load current is the first criteria. The output capacitor needs to supply the load with current when the regulator can not. This situation would occur if there are desired holdup times for the regulator where the output capacitor must hold the output voltage above a certain level for a specified amount of time after the input power is removed. The regulator is temporarily not able to supply sufficient output current if there is a large, fast increase in the current needs of the load such as transitioning from no load to a full load. The regulator usually needs two or more clock cycles for the control loop to see the change in load current and output voltage and adjust the duty cycle to react to the change. The output capacitor must be sized to supply the extra current to the load until the control loop responds to the load change. The output capacitance must be large enough to supply the difference in current for two clock cycles while only

allowing a tolerable amount of droop in the output voltage. Equation 26 shows the minimum output capacitance necessary to accomplish this.

For this example, the transient load response is specified as a 3% change in V_{out} for a load step from 1.5 A (25% load) to 4.5 A (75% load). For this example, $\Delta I_{out} = 4.5 - 1.5 = 3.0$ A and $\Delta V_{out} = 0.04 \times 1.8 = 0.072$ V. Using these numbers gives a minimum capacitance of 83 μ F. This value does not take the ESR of the output capacitor into account in the output voltage change. For ceramic capacitors, the ESR is usually small enough to ignore in this calculation.

Equation 27 calculates the minimum output capacitance needed to meet the output voltage ripple specification. Where f_{sw} is the switching frequency, V_{ripple} is the maximum allowable output voltage ripple, and I_{ripple} is the inductor ripple current. In this case, the maximum output voltage ripple is 30 mV. Under this requirement, Equation 27 yields 7 μ F.

$$C_o > \frac{2 \times \Delta I_{out}}{f_{sw} \times \Delta V_{out}} \quad (26)$$

$$C_o > \frac{1}{8 \times f_{sw}} \times \frac{1}{\frac{V_{ripple}}{I_{ripple}}} \quad (27)$$

where

- ΔI_{out} is the change in output current
- f_{sw} is the regulators switching frequency
- and ΔV_{out} is the allowable change in the output voltage

Equation 28 calculates the maximum ESR an output capacitor can have to meet the output voltage ripple specification. Equation 28 indicates the ESR should be less than 18 m Ω . In this case, the ESR of the ceramic capacitor is much less than 18 m Ω .

Additional capacitance de-ratings for aging, temperature and DC bias must be factored in which increases this minimum value. For this example, five 22- μ F, 10-V X5R ceramic capacitors with 3 m Ω of ESR are used. The estimated capacitance after derating by a factor 0.75 is 82.5 μ F.

Capacitors generally have limits to the amount of ripple current they can handle without failing or producing excess heat. An output capacitor that can support the inductor ripple current must be specified. Some capacitor data sheets specify the RMS (Root Mean Square) value of the maximum ripple current. Equation 29 can be used to calculate the RMS ripple current the output capacitor needs to support. For this application, Equation 29 yields 520 mA.

$$R_{esr} < \frac{V_{ripple}}{I_{ripple}} \quad (28)$$

$$I_{corms} = \frac{V_{out} \times (V_{inmax} - V_{out})}{\sqrt{12} \times V_{inmax} \times L1 \times f_{sw}} \quad (29)$$

8.2.2.4 Step Four: Select the Input Capacitor

The TPS54618C-Q1 requires a high-quality ceramic, type X5R or X7R, input decoupling capacitor of at least 10 μ F of effective capacitance and in some applications, a bulk capacitance. The effective capacitance includes

any DC bias effects. The voltage rating of the input capacitor must be greater than the maximum input voltage. The capacitor must also have a ripple current rating greater than the maximum input current ripple of the TPS54618C-Q1. The input ripple current can be calculated using [Equation 30](#).

The value of a ceramic capacitor varies significantly over temperature and the amount of DC bias applied to the capacitor. The capacitance variations due to temperature can be minimized by selecting a dielectric material that is stable over temperature. X5R and X7R ceramic dielectrics are usually selected for power regulator capacitors because they have a high capacitance to volume ratio and are fairly stable over temperature. The output capacitor must also be selected with the DC bias taken into account. The capacitance value of a capacitor decreases as the DC bias across a capacitor increases.

For this example design, a ceramic capacitor with at least a 10-V voltage rating is required to support the maximum input voltage. For this example, two 10-μF and one 0.1-μF 10-V capacitors in parallel have been selected. The input capacitance value determines the input ripple voltage of the regulator. The input voltage ripple can be calculated using [Equation 31](#). Using the design example values (Ioutmax = 6 A, Cin = 20 μF, Fsw = 1 MHz) yields an input voltage ripple of 149 mV and an RMS input ripple current of 2.94 A.

$$I_{c\text{rms}} = I_{\text{out}} \times \sqrt{\frac{V_{\text{out}}}{V_{\text{inmin}}} \times \frac{(V_{\text{inmin}} - V_{\text{out}})}{V_{\text{inmin}}}} \quad (30)$$

$$\Delta V_{\text{in}} = \frac{I_{\text{outmax}} \times 0.25}{C_{\text{in}} \times f_{\text{sw}}} \quad (31)$$

8.2.2.5 Step Five: Choose the Soft-Start Capacitor

The slow-start capacitor determines the minimum amount of time it takes for the output voltage to reach its nominal programmed value during power up. This is useful if a load requires a controlled voltage slew rate. This is also used if the output capacitance is very large and would require large amounts of current to quickly charge the capacitor to the output voltage level. The large currents necessary to charge the capacitor may make the TPS54618C-Q1 reach the current limit or excessive current draw from the input power supply can cause the input voltage rail to sag. Limiting the output voltage slew rate solves both of these problems.

The slow-start capacitor value can be calculated using [Equation 32](#). For the example circuit, the slow-start time is not too critical because the output capacitor value is 110 μF which does not require much current to charge to 1.8 V. The example circuit has the slow-start time set to an arbitrary value of 4 ms which requires a 10-nF capacitor. In TPS54618C-Q1, I_{ss} is 2.2 μA and V_{ref} is 0.799 V.

$$C_{\text{ss}}(\text{nF}) = \frac{T_{\text{ss}}(\text{ms}) \times I_{\text{ss}}(\mu\text{A})}{V_{\text{ref}}(\text{V})} \quad (32)$$

8.2.2.6 Step Six: Select the Bootstrap Capacitor

A 0.1-μF ceramic capacitor must be connected between the BOOT to PH pin for proper operation. TI recommends using a ceramic capacitor with X5R or better grade dielectric. The capacitor must have 10-V or higher voltage rating.

8.2.2.7 Step Eight: Select Output Voltage and Feedback Resistors

For the example design, 100 kΩ was selected for R6. Using [Equation 33](#), R7 is calculated as 80 kΩ. The nearest standard 1% resistor is 80.6 kΩ.

$$R7 = \frac{V_{\text{ref}}}{V_{\text{o}} - V_{\text{ref}}} R6 \quad (33)$$

8.2.2.7.1 Output Voltage Limitations

Due to the internal design of the TPS54618C-Q1, there is a minimum output voltage limit for any given input voltage. The output voltage can never be lower than the internal voltage reference of 0.799 V. Above 0.799 V, the output voltage can be limited by the minimum controllable ON-time. The minimum output voltage in this case is given by [Equation 34](#).

$$V_{outmin} = O_{ntimemin} \times F_{smax} \times (V_{inmax} - I_{outmin} \times R_{DSmin}) - I_{outmin} \times (R_L + R_{DSmin}) \quad (34)$$

where

- V_{outmin} = minimum achievable output voltage
- $O_{ntimemin}$ = minimum controllable ON-time (75 ns typical, 120 ns no load)
- F_{smax} = maximum switching frequency including tolerance
- V_{inmax} = maximum input voltage
- I_{outmin} = minimum load current
- R_{DSmin} = minimum high-side MOSFET ON-resistance (see [Section 6.5](#))
- R_L = series resistance of output inductor

There is also a maximum achievable output voltage which is limited by the minimum OFF-time. The maximum output voltage is given by [Equation 35](#).

$$V_{outmax} = V_{in} \times \left(1 - \frac{O_{fftimemax}}{t_s} \right) - I_{outmax} \times (R_{DSmax} + R_L) - (0.7 - I_{outmax} \times R_{DSmax}) \times \left(\frac{t_{dead}}{t_s} \right) \quad (35)$$

where

- V_{outmax} = maximum achievable output voltage
- V_{in} = minimum input voltage
- $O_{fftimemax}$ = maximum OFF-time (90 ns typical for adequate margin)
- $t_s = 1/F_s$
- I_{outmax} = maximum current
- R_{DSmax} = maximum high-side MOSFET ON-resistance (see [Section 6.5](#))
- R_L = DCR of the inductor
- t_{dead} = dead time (60 ns)

8.2.2.8 Step Nine: Select Loop Compensation Components

There are several industry techniques used to compensate DC–DC regulators. The method presented here is easy to calculate and yields high phase margins. For most conditions, the regulator has a phase margin between 60 and 90 degrees. The method presented here ignores the effects of the slope compensation that is internal to the TPS54618C-Q1. Because the slope compensation is ignored, the actual cross over frequency is usually lower than the cross over frequency used in the calculations. Use [SwitcherPro™](#) software for a more accurate design.

To get started, the modulator pole, f_{pmod} , and the esr zero, f_{z1} , must be calculated using [Equation 36](#) and [Equation 37](#). For C_{OUT} , the derated capacitance value is 82.5 μ F. Use [Equation 38](#) and [Equation 39](#) to estimate a starting point for the crossover frequency, f_c . For the example design, f_{pmod} is 6.43 kHz and f_{zmod} is 643 kHz. [Equation 38](#) is the geometric mean of the modulator pole and the esr zero and [Equation 39](#) is the mean of modulator pole and the switching frequency. [Equation 38](#) yields 64.3 kHz and [Equation 39](#) gives 56.7 kHz. The lower value of [Equation 38](#) or [Equation 39](#) is the maximum recommended crossover frequency. For this example, a lower f_c value of 40 kHz is specified. Next, the compensation components are calculated. A resistor in series with a capacitor is used to create a compensating zero. A capacitor in parallel to these two components forms the compensating pole (if needed).

$$f_{p\ mod} = \frac{I_{outmax}}{2\pi \times V_{out} \times C_{out}} \quad (36)$$

$$f_{z \text{ mod}} = \frac{1}{2\pi \times \text{Resr} \times \text{Cout}} \quad (37)$$

$$f_c = \sqrt{f_{p \text{ mod}} \times f_{z \text{ mod}}} \quad (38)$$

$$f_c = \sqrt{f_{p \text{ mod}} \times \frac{f_{\text{sw}}}{2}} \quad (39)$$

The compensation design takes the following steps:

1. Set up the anticipated crossover frequency. Use [Equation 40](#) to calculate the resistor value of the compensation network. In this example, the anticipated crossover frequency (f_c) is 40 kHz. The power stage gain ($g_{m_{ps}}$) is 25 A/V and the error amplifier gain ($g_{m_{ea}}$) is 245 $\mu\text{A/V}$.

$$R3 = \frac{2\pi \times f_c \times V_o \times C_o}{G_m \times V_{\text{ref}} \times V_{I_{gm}}} \quad (40)$$

2. Place compensation zero at the pole formed by the load resistor and the output capacitor. The capacitor of the compensation network can be calculated from [Equation 41](#).

$$C4 = \frac{R_o \times C_o}{R3} \quad (41)$$

3. An additional pole can be added to attenuate high-frequency noise. In this application, it is not necessary to add it.

From the previously listed procedures, the compensation network includes a 7.50-k Ω resistor and a 3300-pF capacitor.

8.2.3 Application Curves

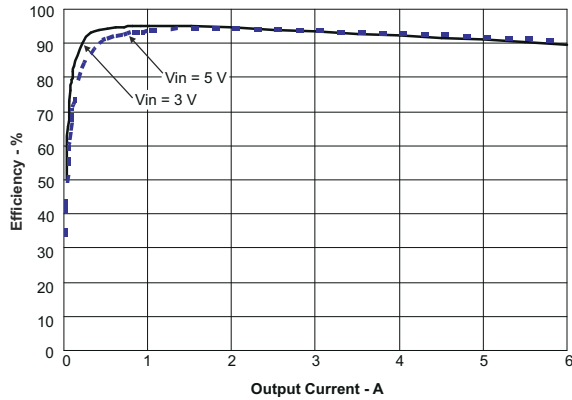

Figure 8-2. Efficiency vs Load Current

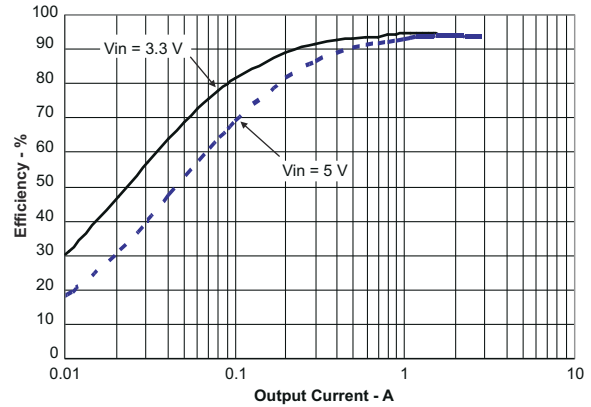

Figure 8-3. Efficiency vs Load Current

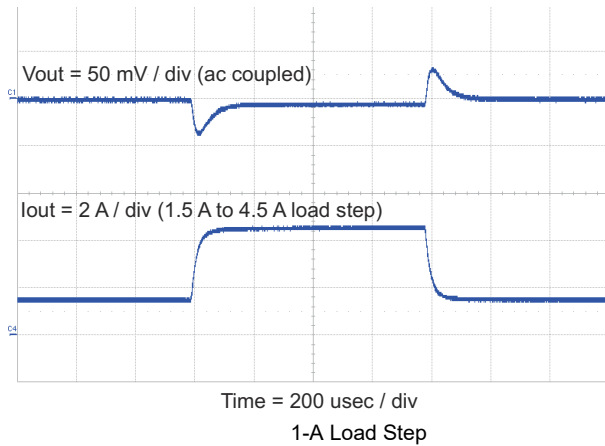

Figure 8-4. Transient Response

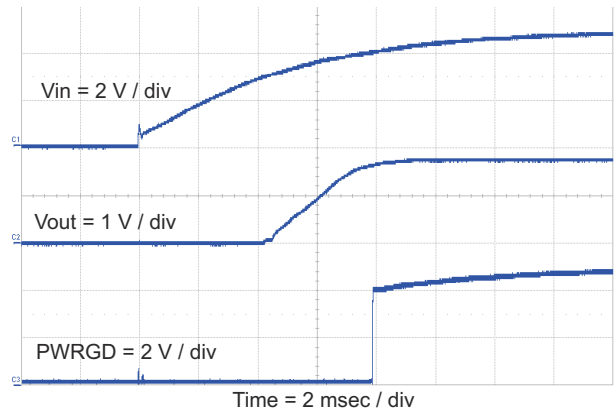

Figure 8-5. Power Up, V_{OUT} , V_{IN}

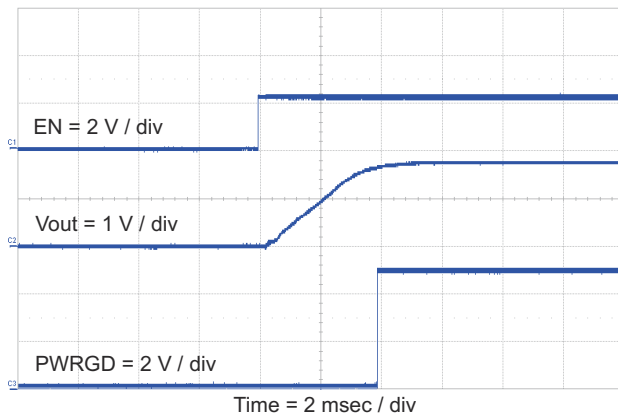

Figure 8-6. Power Up, V_{OUT} , EN

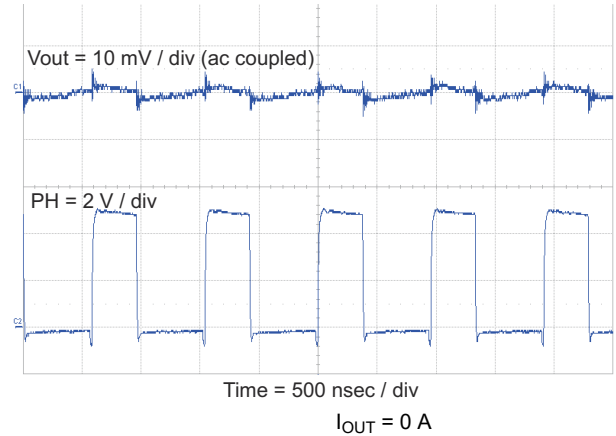

Figure 8-7. Output Ripple

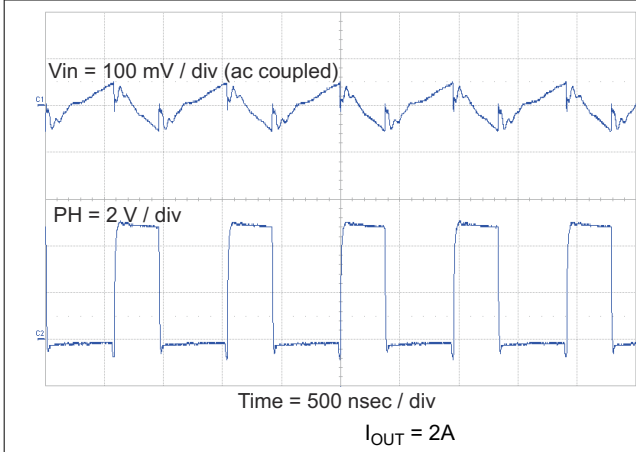

Figure 8-8. Input Ripple

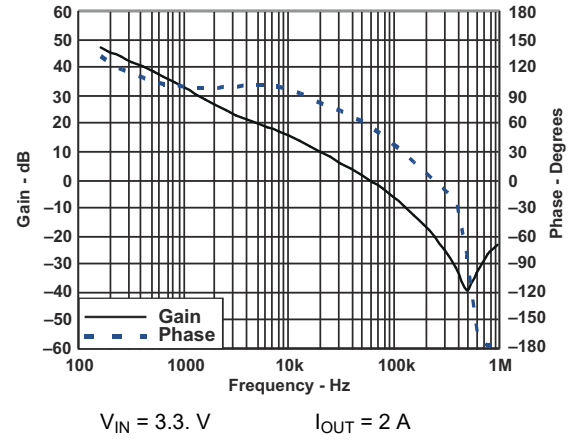

Figure 8-9. Closed-Loop Response

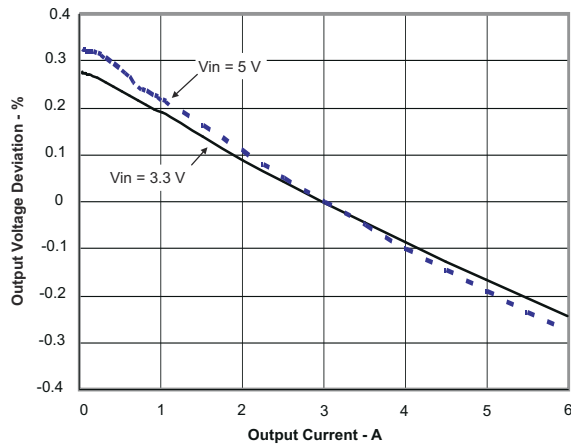

Figure 8-10. Load Regulation vs Load Current

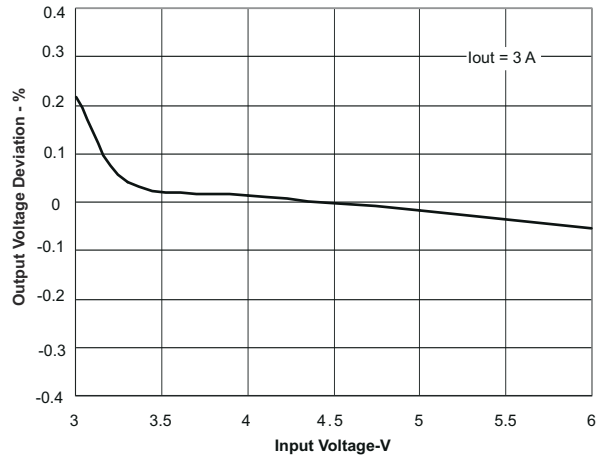

Figure 8-11. Regulation vs Input Voltage

9 Power Supply Recommendations

These devices are designed to operate from an input voltage supply between 2.95 V and 6 V. This supply must be well regulated. Proper bypassing of input supplies and internal regulators is also critical for noise performance, as is PCB layout and grounding scheme. See the recommendations in [Section 10.1](#).

10 Layout

10.1 Layout Guidelines

Layout is a critical portion of good power supply design. There are several signal paths that conduct fast changing currents or voltages that can interact with stray inductance or parasitic capacitance to generate noise or degrade the power supplies performance.

- Minimize the loop area formed by the bypass capacitor connections and the VIN pins. See [Figure 10-1](#) for a PCB layout example.
- The GND pins and AGND pin should be tied directly to the power pad under the TPS54618C-Q1 device. The power pad must be connected to any internal PCB ground planes using multiple vias directly under the device. Additional vias can be used to connect the top-side ground area to the internal planes near the input and output capacitors. For operation at full rated load, the top-side ground area along with any additional internal ground planes must provide adequate heat dissipating area.
- Place the input bypass capacitor as close to the device as possible.
- Route the PH pin to the output inductor. Because the PH connection is the switching node, place the output inductor close to the PH pins. Minimize the area of the PCB conductor to prevent excessive capacitive coupling.
- The boot capacitor must also be located close to the device.
- The sensitive analog ground connections for the feedback voltage divider, compensation components, soft-start capacitor, and frequency set resistor must be connected to a separate analog ground trace as shown in [Figure 10-1](#).
- The RT/CLK pin is particularly sensitive to noise so the RT resistor must be located as close as possible to the device and routed with minimal trace lengths.
- The additional external components can be placed approximately as shown. It is possible to obtain acceptable performance with alternate PCB layouts, however, this layout has been shown to produce good results and can be used as a guide.

10.2 Layout Example

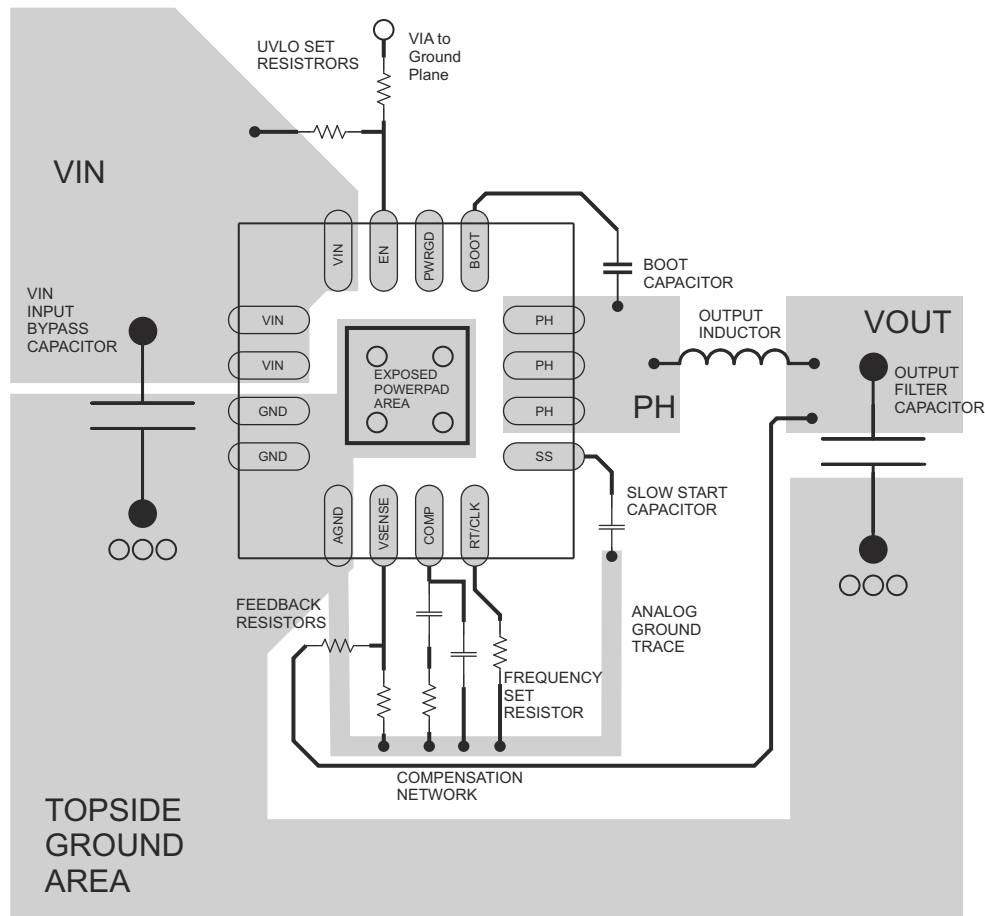

○ VIA to Ground Plane

Figure 10-1. PCB Layout Example

10.3 Power Dissipation Estimate

The following formulas show how to estimate the IC power dissipation under continuous conduction mode (CCM) operation. The power dissipation of the IC (P_{tot}) includes conduction loss (P_{con}), dead time loss (P_d), switching loss (P_{sw}), gate drive loss (P_{gd}), and supply current loss (P_q).

$$P_{con} = I_o^2 \times R_{DS_on_Temp} \quad (42)$$

where

- I_o is the output current (A)
- $R_{DS_on_Temp}$ is the ON-resistance of the high-side MOSFET with given temperature (Ω)

$$P_d = f_{sw} \times I_o \times 0.7 \times 40 \times 10^{-9} \quad (43)$$

where

- I_o is the output current (A)
- f_{sw} is the switching frequency (Hz)

$$P_{sw} = 1/2 \times V_{in} \times I_o \times f_{sw} \times 13 \times 10^{-9} \quad (44)$$

where

- I_O is the output current (A)
- V_{in} is the input voltage (V)
- f_{sw} is the switching frequency (Hz)

$$P_{gd} = 2 \times V_{in} \times f_{sw} \times 10 \times 10^{-9} \quad (45)$$

where

- V_{in} is the input voltage (V)
- f_{sw} is the switching frequency (Hz)

$$P_q = V_{in} \times 515 \times 10^{-6} \quad (46)$$

where

- V_{in} is the input voltage (V)

$$P_{tot} = P_{con} + P_d + P_{sw} + P_{gd} + P_q \quad (47)$$

where

- P_{tot} is the total device power dissipation (W)

For given T_A :

$$T_J = T_A + R_{th} \times P_{tot} \quad (48)$$

where

- T_A is the ambient temperature ($^{\circ}\text{C}$)
- T_J is the junction temperature ($^{\circ}\text{C}$)
- R_{th} is the thermal resistance of the package ($^{\circ}\text{C}/\text{W}$)

For given $T_{Jmax} = 150^{\circ}\text{C}$:

$$T_{Amax} = T_{Jmax} - R_{th} \times P_{tot} \quad (49)$$

where

- P_{tot} is the total device power dissipation (W)
- R_{th} is the thermal resistance of the package ($^{\circ}\text{C}/\text{W}$)
- T_{Jmax} is maximum junction temperature ($^{\circ}\text{C}$)
- T_{Amax} is maximum ambient temperature ($^{\circ}\text{C}$)

There are additional power losses in the regulator circuit due to the inductor AC and DC losses and trace resistance that impact the overall efficiency of the regulator.

11 Device and Documentation Support

11.1 Device Support

11.1.1 Developmental Support

For developmental support, see the following:

- Evaluation Module for TPS54618C-Q1 Synchronous Step-Down SWIFT™ DC/DC Converter, [HPA606](#)

11.2 Receiving Notification of Documentation Updates

To receive notification of documentation updates, navigate to the device product folder on [ti.com](#). Click on *Subscribe to updates* to register and receive a weekly digest of any product information that has changed. For change details, review the revision history included in any revised document.

11.3 Support Resources

[TI E2E™ support forums](#) are an engineer's go-to source for fast, verified answers and design help — straight from the experts. Search existing answers or ask your own question to get the quick design help you need.

Linked content is provided "AS IS" by the respective contributors. They do not constitute TI specifications and do not necessarily reflect TI's views; see TI's [Terms of Use](#).

11.4 Trademarks

SwitcherPro™ and TI E2E™ are trademarks of Texas Instruments.

All trademarks are the property of their respective owners.

11.5 Electrostatic Discharge Caution



This integrated circuit can be damaged by ESD. Texas Instruments recommends that all integrated circuits be handled with appropriate precautions. Failure to observe proper handling and installation procedures can cause damage.

ESD damage can range from subtle performance degradation to complete device failure. Precision integrated circuits may be more susceptible to damage because very small parametric changes could cause the device not to meet its published specifications.

11.6 Glossary

[TI Glossary](#) This glossary lists and explains terms, acronyms, and definitions.

12 Mechanical, Packaging, and Orderable Information

The following pages include mechanical, packaging, and orderable information. This information is the most current data available for the designated devices. This data is subject to change without notice and revision of this document. For browser-based versions of this data sheet, refer to the left-hand navigation.

PACKAGING INFORMATION

Orderable Device	Status (1)	Package Type	Package Drawing	Pins	Package Qty	Eco Plan (2)	Lead finish/ Ball material (6)	MSL Peak Temp (3)	Op Temp (°C)	Device Marking (4/5)	Samples
TPS54618CQRTERQ1	ACTIVE	WQFN	RTE	16	3000	RoHS & Green	NIPDAU	Level-3-260C-168 HR	-40 to 125	618CQ	Samples

(1) The marketing status values are defined as follows:

ACTIVE: Product device recommended for new designs.

LIFEBUY: TI has announced that the device will be discontinued, and a lifetime-buy period is in effect.

NRND: Not recommended for new designs. Device is in production to support existing customers, but TI does not recommend using this part in a new design.

PREVIEW: Device has been announced but is not in production. Samples may or may not be available.

OBSOLETE: TI has discontinued the production of the device.

(2) **RoHS:** TI defines "RoHS" to mean semiconductor products that are compliant with the current EU RoHS requirements for all 10 RoHS substances, including the requirement that RoHS substance do not exceed 0.1% by weight in homogeneous materials. Where designed to be soldered at high temperatures, "RoHS" products are suitable for use in specified lead-free processes. TI may reference these types of products as "Pb-Free".

RoHS Exempt: TI defines "RoHS Exempt" to mean products that contain lead but are compliant with EU RoHS pursuant to a specific EU RoHS exemption.

Green: TI defines "Green" to mean the content of Chlorine (Cl) and Bromine (Br) based flame retardants meet JS709B low halogen requirements of <=1000ppm threshold. Antimony trioxide based flame retardants must also meet the <=1000ppm threshold requirement.

(3) MSL, Peak Temp. - The Moisture Sensitivity Level rating according to the JEDEC industry standard classifications, and peak solder temperature.

(4) There may be additional marking, which relates to the logo, the lot trace code information, or the environmental category on the device.

(5) Multiple Device Markings will be inside parentheses. Only one Device Marking contained in parentheses and separated by a "-" will appear on a device. If a line is indented then it is a continuation of the previous line and the two combined represent the entire Device Marking for that device.

(6) Lead finish/Ball material - Orderable Devices may have multiple material finish options. Finish options are separated by a vertical ruled line. Lead finish/Ball material values may wrap to two lines if the finish value exceeds the maximum column width.

Important Information and Disclaimer:The information provided on this page represents TI's knowledge and belief as of the date that it is provided. TI bases its knowledge and belief on information provided by third parties, and makes no representation or warranty as to the accuracy of such information. Efforts are underway to better integrate information from third parties. TI has taken and continues to take reasonable steps to provide representative and accurate information but may not have conducted destructive testing or chemical analysis on incoming materials and chemicals. TI and TI suppliers consider certain information to be proprietary, and thus CAS numbers and other limited information may not be available for release.

In no event shall TI's liability arising out of such information exceed the total purchase price of the TI part(s) at issue in this document sold by TI to Customer on an annual basis.

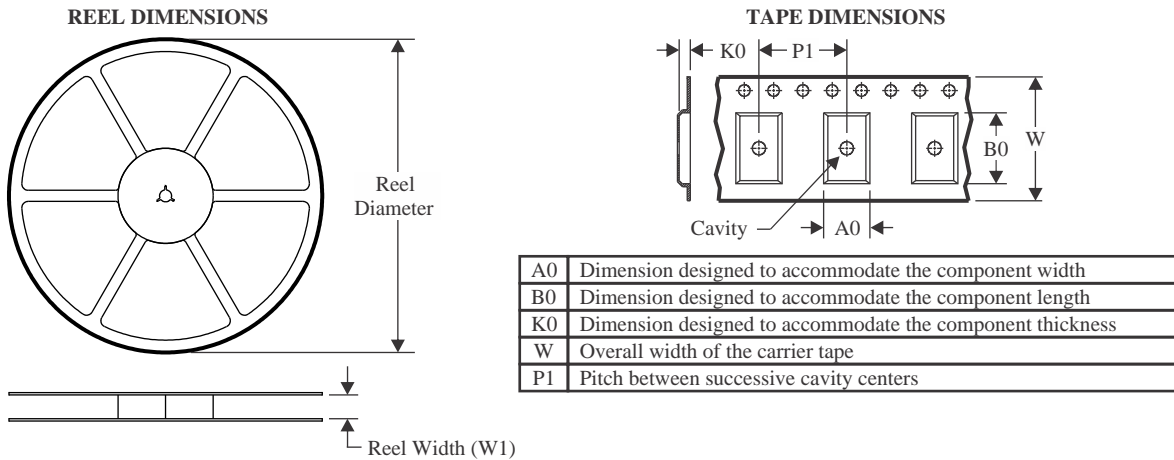
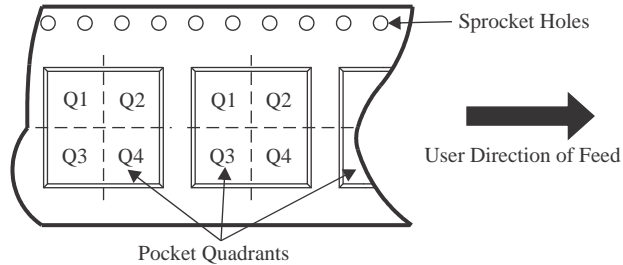
TAPE AND REEL INFORMATION

QUADRANT ASSIGNMENTS FOR PIN 1 ORIENTATION IN TAPE

*All dimensions are nominal

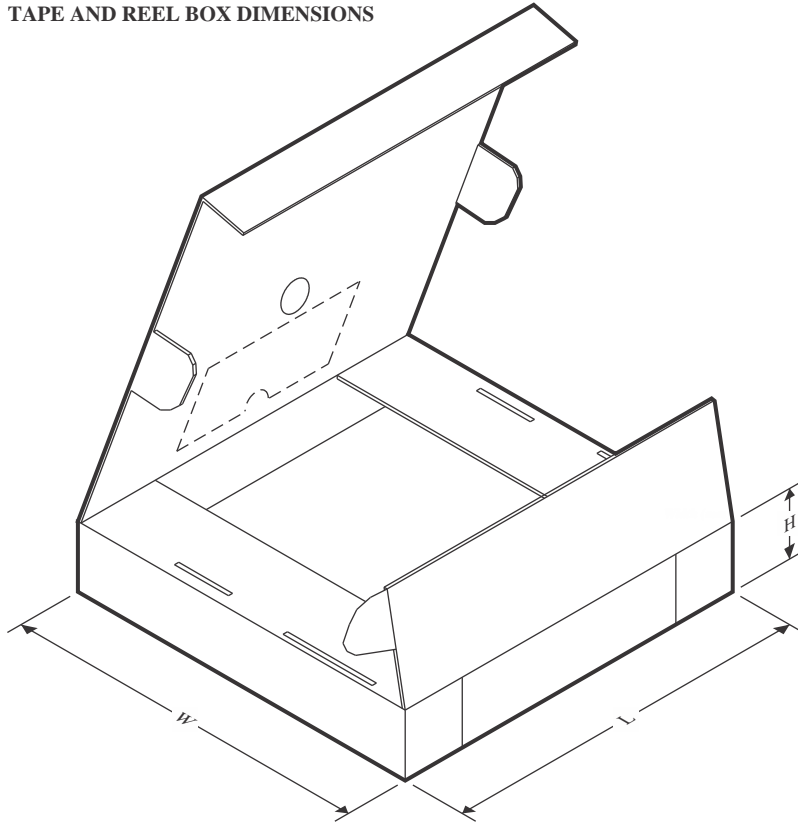
Device	Package Type	Package Drawing	Pins	SPQ	Reel Diameter (mm)	Reel Width W1 (mm)	A0 (mm)	B0 (mm)	K0 (mm)	P1 (mm)	W (mm)	Pin1 Quadrant
TPS54618CQRTERQ1	WQFN	RTE	16	3000	330.0	12.4	3.3	3.3	1.1	8.0	12.0	Q2

TAPE AND REEL BOX DIMENSIONS

*All dimensions are nominal

Device	Package Type	Package Drawing	Pins	SPQ	Length (mm)	Width (mm)	Height (mm)
TPS54618CQRTERQ1	WQFN	RTE	16	3000	367.0	367.0	35.0

GENERIC PACKAGE VIEW

RTE 16

WQFN - 0.8 mm max height

3 x 3, 0.5 mm pitch

PLASTIC QUAD FLATPACK - NO LEAD

This image is a representation of the package family, actual package may vary.
Refer to the product data sheet for package details.

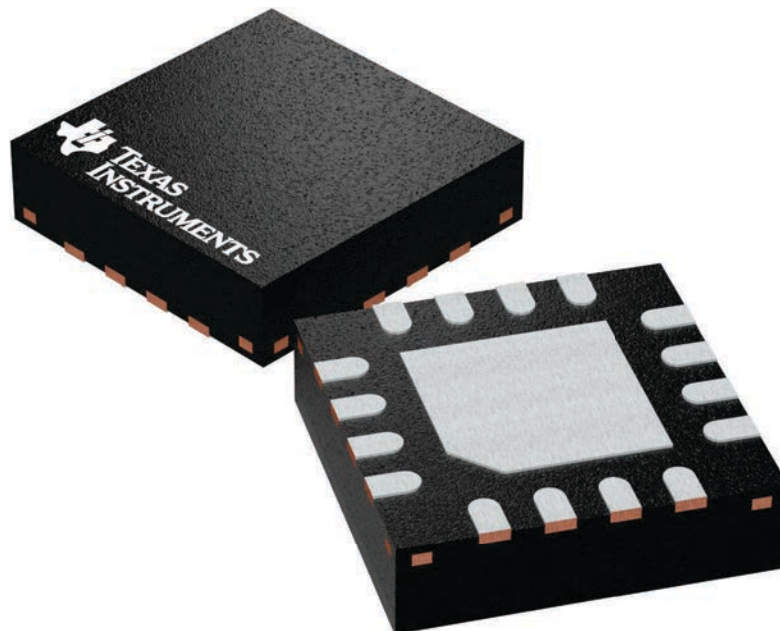

4225944/A

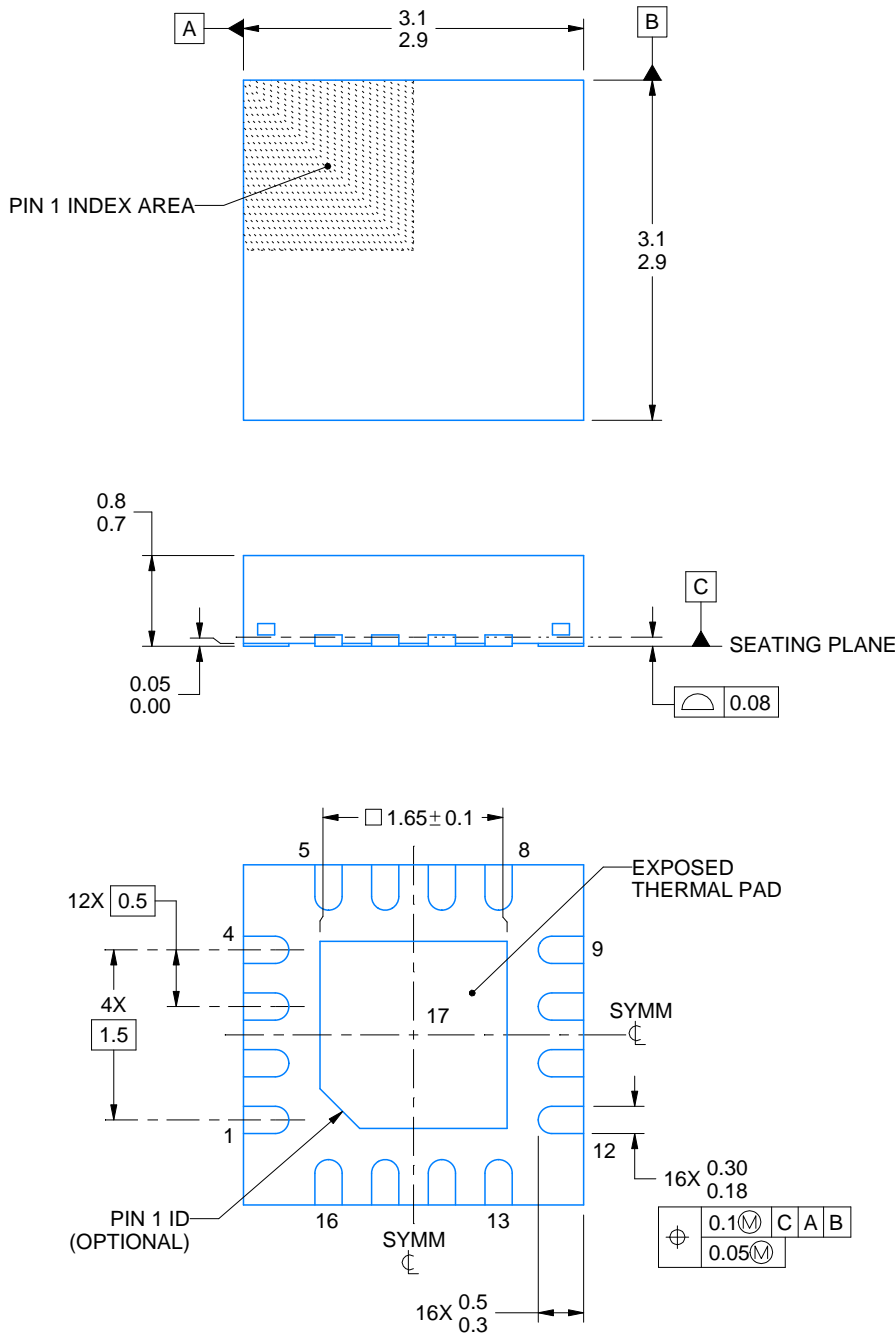

4219119/A 03/2018

NOTES:

1. All linear dimensions are in millimeters. Any dimensions in parenthesis are for reference only. Dimensioning and tolerancing per ASME Y14.5M.
2. This drawing is subject to change without notice.
3. The package thermal pad must be soldered to the printed circuit board for thermal and mechanical performance.

EXAMPLE BOARD LAYOUT

RTE0016F

WQFN - 0.8 mm max height

PLASTIC QUAD FLATPACK - NO LEAD

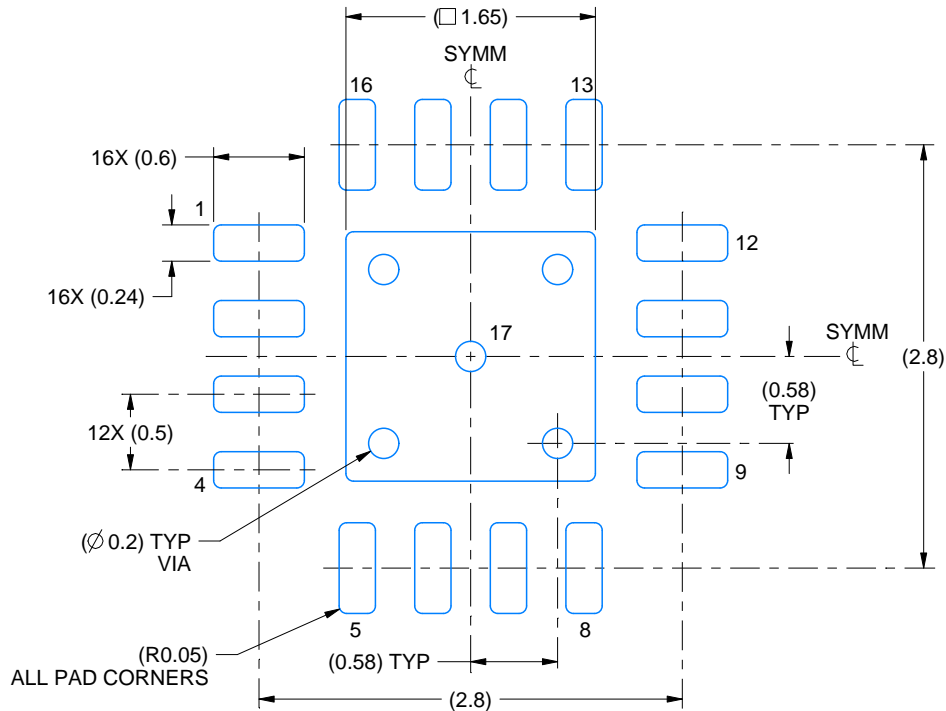

LAND PATTERN EXAMPLE
EXPOSED METAL SHOWN
SCALE:20X

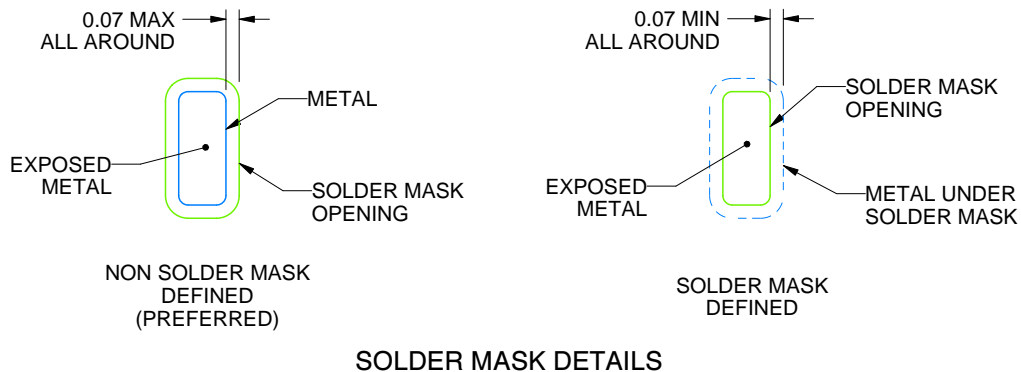

SOLDER MASK DETAILS

4219119/A 03/2018

NOTES: (continued)

- This package is designed to be soldered to a thermal pad on the board. For more information, see Texas Instruments literature number SLUA271 (www.ti.com/lit/sluea271).
- Vias are optional depending on application, refer to device data sheet. If any vias are implemented, refer to their locations shown on this view. It is recommended that vias under paste be filled, plugged or tented.

EXAMPLE STENCIL DESIGN

RTE0016F

WQFN - 0.8 mm max height

PLASTIC QUAD FLATPACK - NO LEAD

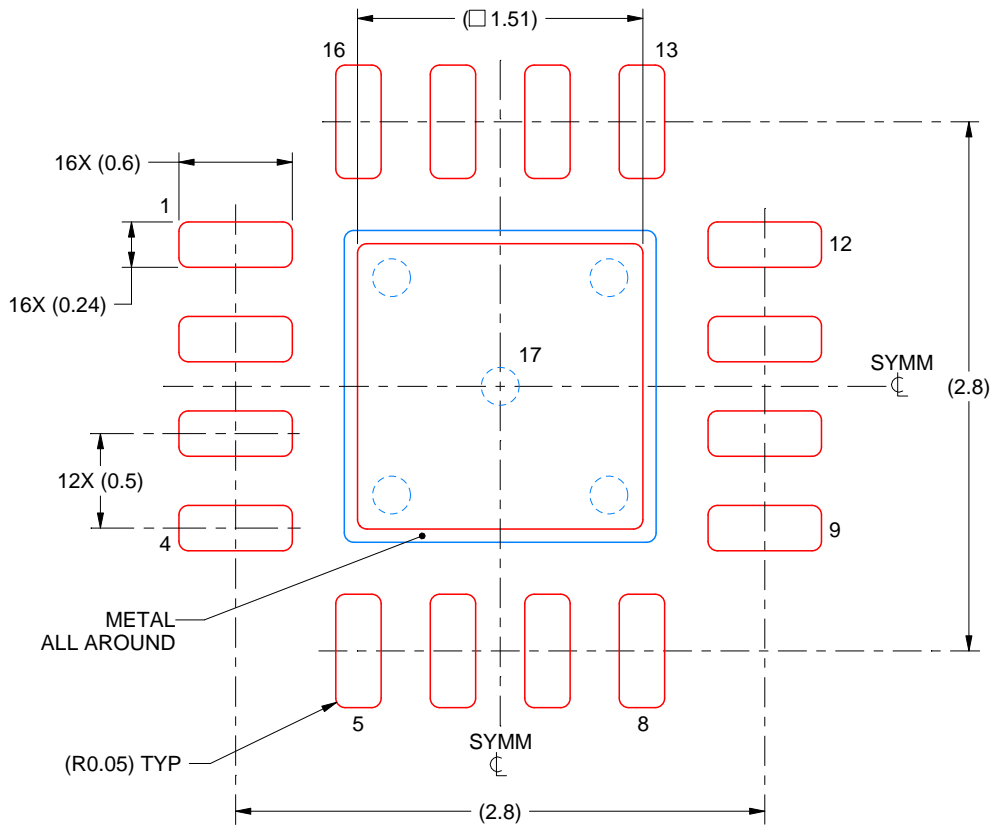

SOLDER PASTE EXAMPLE
BASED ON 0.125 mm THICK STENCIL

EXPOSED PAD 17:
84% PRINTED SOLDER COVERAGE BY AREA UNDER PACKAGE
SCALE:25X

4219119/A 03/2018

NOTES: (continued)

6. Laser cutting apertures with trapezoidal walls and rounded corners may offer better paste release. IPC-7525 may have alternate design recommendations.

IMPORTANT NOTICE AND DISCLAIMER

TI PROVIDES TECHNICAL AND RELIABILITY DATA (INCLUDING DATA SHEETS), DESIGN RESOURCES (INCLUDING REFERENCE DESIGNS), APPLICATION OR OTHER DESIGN ADVICE, WEB TOOLS, SAFETY INFORMATION, AND OTHER RESOURCES "AS IS" AND WITH ALL FAULTS, AND DISCLAIMS ALL WARRANTIES, EXPRESS AND IMPLIED, INCLUDING WITHOUT LIMITATION ANY IMPLIED WARRANTIES OF MERCHANTABILITY, FITNESS FOR A PARTICULAR PURPOSE OR NON-INFRINGEMENT OF THIRD PARTY INTELLECTUAL PROPERTY RIGHTS.

These resources are intended for skilled developers designing with TI products. You are solely responsible for (1) selecting the appropriate TI products for your application, (2) designing, validating and testing your application, and (3) ensuring your application meets applicable standards, and any other safety, security, regulatory or other requirements.

These resources are subject to change without notice. TI grants you permission to use these resources only for development of an application that uses the TI products described in the resource. Other reproduction and display of these resources is prohibited. No license is granted to any other TI intellectual property right or to any third party intellectual property right. TI disclaims responsibility for, and you will fully indemnify TI and its representatives against, any claims, damages, costs, losses, and liabilities arising out of your use of these resources.

TI's products are provided subject to [TI's Terms of Sale](#) or other applicable terms available either on [ti.com](https://www.ti.com) or provided in conjunction with such TI products. TI's provision of these resources does not expand or otherwise alter TI's applicable warranties or warranty disclaimers for TI products.

TI objects to and rejects any additional or different terms you may have proposed.

Mailing Address: Texas Instruments, Post Office Box 655303, Dallas, Texas 75265
Copyright © 2023, Texas Instruments Incorporated

Looking for pricing, stock, or lifecycle information?

Click below to explore more details on WIN SOURCE:

 [View TPS54618CQRTERQ1 on WIN SOURCE](#)

 [Texas Instruments](#) Information

Optimize Your Supply Chain with WIN SOURCE Solutions

-  Global Sourcing Solution
-  Obsolete Management
-  Cost Control Management
-  Shortage Management
-  Alternative Solution
-  Excess Inventory Management