



**THE DATASHEET OF  
RT5028AGQW**



## Integrated PMIC with 4-Channel Synchronous Buck Converters, 8 LDOs, and MTP Non-Volatile Memory for Industrial and Automotive Applications

### General Description

The RT5028A is a highly-integrated low-power high-performance analog SOC with PMIC in one single chip designed for Industrial/Automotive applications.

The RT5028A includes four synchronous step-down DC-DC converters and eight LDOs for system power.

The RT5028A also embeds one EEPROM (MTP) for setting sequence and timing etc.

Additionally, the RT5028A PMIC also includes one IRQ report.

### Ordering Information

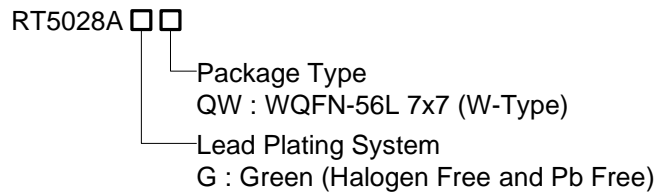

Note :

Richtek products are :

- ▶ RoHS compliant and compatible with the current requirements of IPC/JEDEC J-STD-020.
- ▶ Suitable for use in SnPb or Pb-free soldering processes.

### Features

- Input Voltage Operating Range is 3.3V to 5.5V
- Step-Down Regulator :  $V_{IN}$  Range is 3.3V to 5.5V
  - ▶ Max Current 2.4A/2A/1.6A/2A
  - ▶ Programmable Frequency from 500kHz to 2MHz
  - ▶ I<sup>2</sup>C Programmable Output Level
  - ▶ I<sup>2</sup>C Programmable Operation Mode (Force PWM or Auto PSM/PWM)
  - ▶ I<sup>2</sup>C Programmable Output Discharge Mode (Discharge or Flatting)
- Linear Regulators :  $V_{IN}$  Range is 2.5V to 5.5V
  - ▶ Max Current 0.3A
  - ▶ I<sup>2</sup>C Programmable Output Level
- Embedded 32Bytes MTP for Factory Tuning
  - ▶ External MTP Pin for Write Protection
- Sequence can be Controlled by I<sup>2</sup>C or each EN pins Defined by MASK\_GPIO Pin
- OT/UVP/VIN LV/POWRON Press Time Interrupt (IRQ)
  - ▶ I<sup>2</sup>C Control Interface : Support Fast Mode up to 400kb/s
- Available in AEC-Q100 Grade 3 Qualified
- RoHS Compliant and Halogen Free

### Applications

- Industrial/Automotive

### Simplified Application Circuit

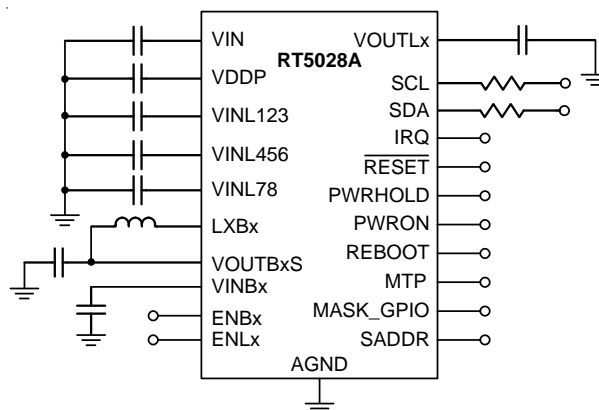

## Marking Information

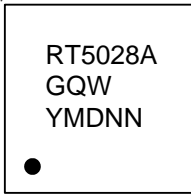

RT5028AGQW : Product Number

YMDNN : Date Code

## Pin Configuration

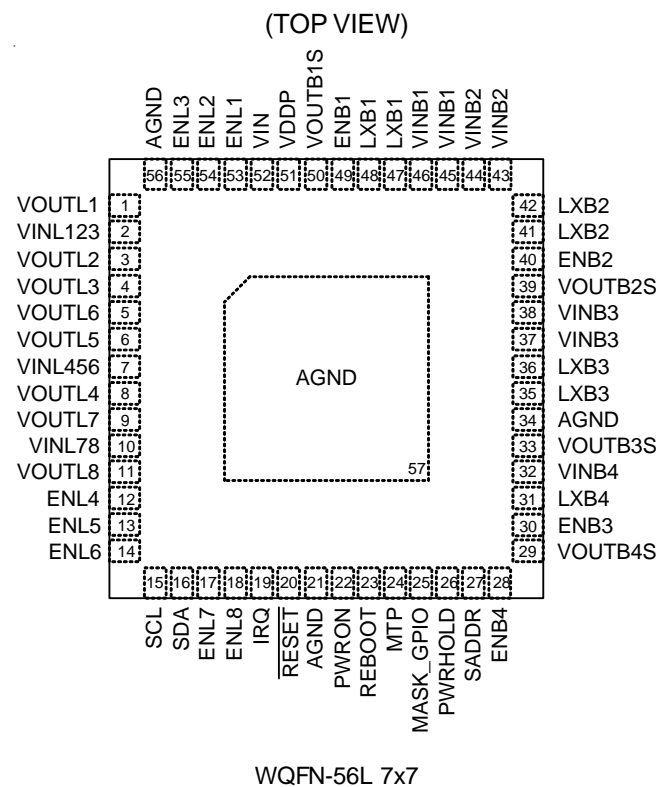

## Functional Pin Description

Pin No.	Pin Name	Pin Function
1	VOUTL1	Output voltage regulation node for LDO1.
2	VINL123	Input power for LDO1, LDO2 and LDO3.
3	VOUTL2	Output voltage regulation node for LDO2.
4	VOUTL3	Output voltage regulation node for LDO3.
5	VOUTL6	Output voltage regulation node for LDO6.
6	VOUTL5	Output voltage regulation node for LDO5.
7	VINL456	Input power for LDO4, LDO5 and LDO6.
8	VOUTL4	Output voltage regulation node for LDO4.
9	VOUTL7	Output voltage regulation node for LDO7.
10	VINL78	Input power for LDO7 and LDO8.
11	VOUTL8	Output voltage regulation node for LDO8.
12	ENL4	Enable control input for LDO4.
13	ENL5	Enable control input for LDO5.
14	ENL6	Enable control input for LDO6.
15	SCL	Clock input for I <sup>2</sup> C. Open-drain output.

Pin No.	Pin Name	Pin Function
16	SDA	Data input for I <sup>2</sup> C. Open-drain output.
17	ENL7	Enable control input for LDO7.
18	ENL8	Enable control input for LDO8.
19	IRQ	Open-drain IRQ output node.
20	RESET	Reset output.
21, 34, 56, 57 (Exposed Pad)	AGND	Analog ground. The exposed pad must be soldered to a large PCB and connected to AGND for maximum power dissipation.
22	PWRON	Manual power on.
23	REBOOT	System power reboot.
24	MTP	MTP write protection pin. Logic low is inhibited and logic high is permit to write.
25	MASK_GPIO	Select I <sup>2</sup> C or EN pin for Bucks and LDOs. Connect a 100kΩ pull-low resistor. As MASK_GPIO is high, ignore all EN pins. As MASK_GPIO is low, EN pins and I <sup>2</sup> C both can control. EN pins priority is higher than I <sup>2</sup> C.
26	PWRHOLD	Power hold input.
27	SADDR	I <sup>2</sup> C slave address.
28	ENB4	Enable control input for Buck4.
29	VOUTB4S	Output voltage regulation node for Buck4.
30	ENB3	Enable control input for Buck3.
31	LXB4	Internal switch node to output inductor connection for Buck4.
32	VINB4	Input power for Buck4.
33	VOUTB3S	Output Voltage regulation node for Buck3.
35, 36	LXB3	Internal switch node to output inductor connection for Buck3.
37, 38	VINB3	Input power for Buck3.
39	VOUTB2S	Output voltage regulation node for Buck2.
40	ENB2	Enable control input for Buck2.
41, 42	LXB2	Internal switch node to output inductor connection for Buck2.
43, 44	VINB2	Input power for Buck2.
45, 46	VINB1	Input power for Buck1.
47, 48	LXB1	Internal switch node to output inductor connection for Buck1.
49	ENB1	Enable control input for Buck1.
50	VOUTB1S	Output voltage regulation node for Buck1
51	VDDP	Internal bias regulator voltage. External load on this pin is not allowed.
52	VIN	Input power for analog base.
53	ENL1	Enable control input for LDO1.
54	ENL2	Enable control input for LDO2.
55	ENL3	Enable control input for LDO3.

Functional Block Diagram

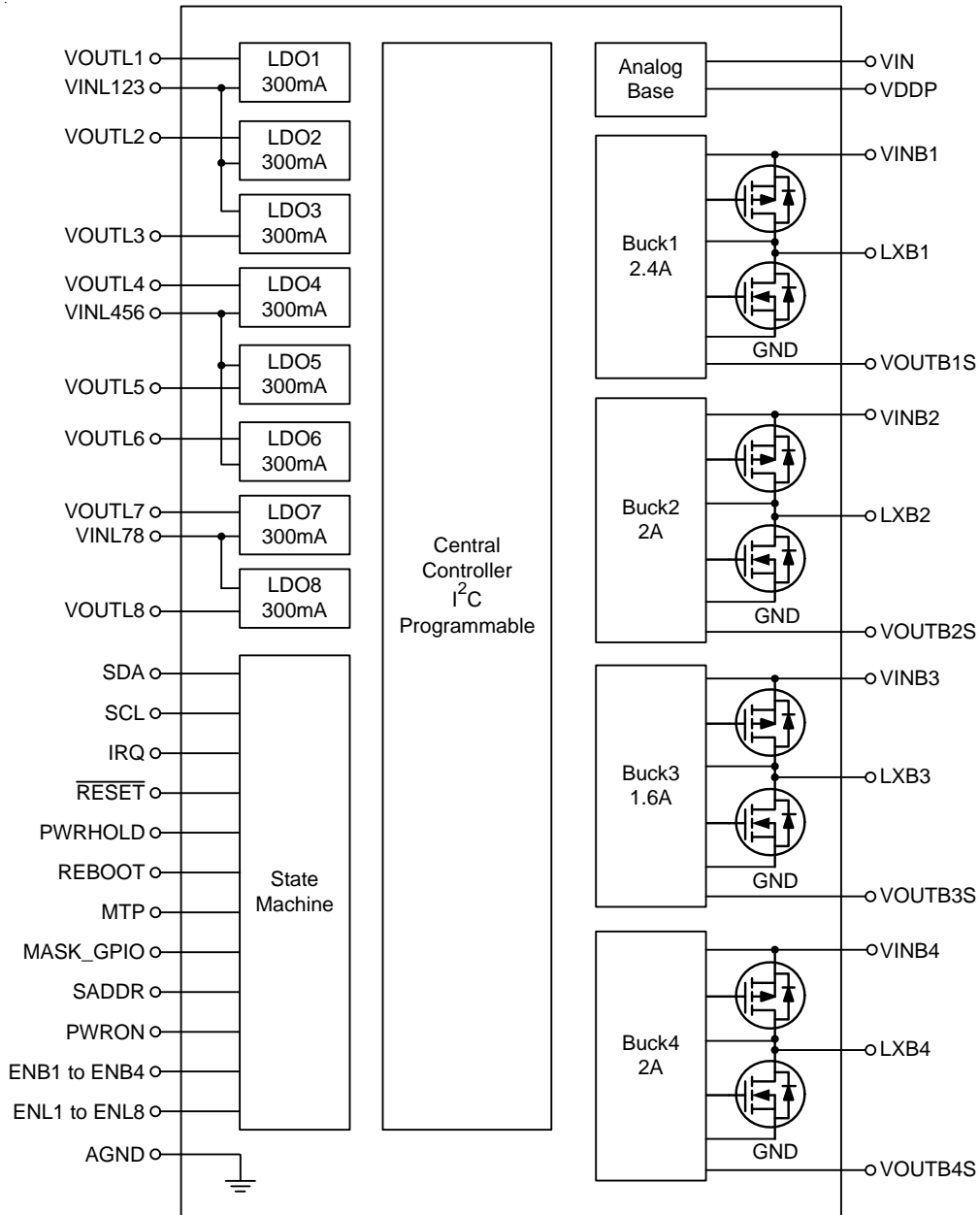

**Absolute Maximum Ratings** (Note 1)

- Analog Base Input Voltage, VIN ----- -0.3V to 6V
- PMIC Input Voltage, VINL123/456/78, VINB1/2/3/4 ----- -0.3V to 6V
- PMIC Output Voltage, VOUTLx, VOUTBxS, LXBx ----- -0.3V to 6V
- PMIC related Other Pins ----- -0.3V to 6V
- Power Dissipation, PD @ TA = 25°C  
 WQFN-56L 7x7 ----- 3.7W
- Package Thermal Resistance (Note 2)  
 WQFN-56L 7x7, θJA ----- 27°C/W  
 WQFN-56L 7x7, θJC ----- 7°C/W
- Junction Temperature ----- 150°C
- Lead Temperature (Soldering, 10 sec.) ----- 260°C
- Storage Temperature Range ----- -65°C to 150°C
- ESD Susceptibility (Note 3)  
 HBM (Human Body Model) ----- 2kV  
 MM (Machine Model) ----- 200V

**Recommended Operating Conditions** (Note 4)

- Junction Temperature Range ----- -40°C to 125°C
- Ambient Temperature Range ----- -40°C to 85°C

**Electrical Characteristics**

(Note 5)

Parameter	Symbol	Test Conditions	Min	Typ	Max	Unit
AMR for VIN			--	--	6	V
Operation Voltage of VIN		As fsw > 1MHz, 3.3V ≤ VIN ≤ 5.5V. If fsw ≤ 1MHz, VIN ≥ 4V.	3.3	--	5.5	V
<b>PMIC</b>						
Quiescent Current	IIN	VIN = 5V, LDOs, Bucks are ON with no load. Bucks operate in auto mode (Reg0x06 = FFh)	500	700	950	µA
		VIN = 5V, SCL = SDA = 0V, LDO and Bucks are OFF, Disable PMIC (Reg0x15[7] = 1)	5	30	60	
Warning for Die Temperature	OTW	Temperature 1	--	100	--	°C
		Temperature 2	--	125	--	
Over-Temperature Protection	OTP		--	165	--	°C
OTP and Warning Hysteresis			--	10	--	°C
Input Pull-Low 100kΩ Resistor	RLow	VIN = 5V, temperature = -40°C to 85°C	70	115	160	kΩ

Parameter	Symbol	Test Conditions	Min	Typ	Max	Unit	
<b>Buck1 to Buck4</b>							
Input Voltage	$V_{INB}$		3.3	--	5.5	V	
Consumption Current	$I_{VINB}$	AUTO mode $I_{OUT} = 0mA$ , each buck	10	30	50	$\mu A$	
Output Voltage Accuracy	$V_{OUTAcc}$	$3.1V < V_{IN} < 5.5V$ , $1mA < I_{OUT} < I_{MAX}$ , $-40 < T_A < 85^{\circ}C$	-3	--	3	%	
Switching Frequency	$f_{sw}$	I <sup>2</sup> C programmable	0.43	--	2	MHz	
Switching Frequency Accuracy		$1MHz < f_{sw}$	-10	--	10	%	
		$f_{sw} \leq 1MHz$	-20	--	20		
Peak Current Limit	OCP	Buck1	3.1	4.4	5.8	A	
		Buck2	2.8	4	5.2		
		Buck3	2.6	3.7	4.8		
		Buck4	2.8	4.1	5.3		
Under-Voltage Protection	UVP	$V_{OUTB1S}$ to $V_{OUTB4S} < 0.66 \times (V_{OUT} Target)$	56	66	76	%	
Maximum Output Current	$I_{MAX}$	Buck1	2.4	--	--	A	
		Buck2	2	--	--		
		Buck3	1.6	--	--		
		Buck4	2.0	--	--		
High-Side On-Resistance	$R_{pon}$	$V_{IN} = 3.7V$	50	150	250	$m\Omega$	
Low-Side On-Resistance	$R_{non}$	$V_{IN} = 3.7V$	40	110	160	$m\Omega$	
<b>LDO1 to LDO8</b>							
Input Voltage for VINL123/456/78	$V_{INL}$		2.5	--	5.5	V	
Output Voltage LDO123/78	$V_{OUTL}$	$3.1V \leq V_{IN} \leq 5.5V$ , $50\mu A \leq I_{OUT} \leq I_{MAX}$ $-40 < T_A < 85^{\circ}C$	-3	--	3	%	
Output Voltage LDO456	$V_{OUTL}$	$3.1V \leq V_{IN} \leq 5.5V$ , $50\mu A \leq I_{OUT} \leq I_{MAX}$ $-40 < T_A < 85^{\circ}C$	-3	--	3	%	
Output Current	$I_{OUT}$		300	--	--	mA	
Output Short Current	$I_{sht}$		330	450	600	mA	
Voltage Difference	$V_{IN} - V_{OUT}$	$V_{IN} > 3.1V$	$V_{IN} = V_{SET}$ , $I_{OUT} = I_{OUTMAX}$	0.05	0.1	0.3	V
		$V_{IN} > 2.5V$		0.05	0.11	0.5	
Supply Current	$I_{SS}$	$I_{OUT} = 0mA$	10	50	75	$\mu A$	
Shutdown Current	$I_{OFF}$		0	1	2	$\mu A$	

Parameter	Symbol	Test Conditions	Min	Typ	Max	Unit
<b>Control Input Pin Electrical Characteristics</b>						
Voltage Output Low	$V_{OL}$		--	--	0.4	V
Input Voltage	High-Level	$V_{IH}$	1.5	--	--	V
	Low-Level	$V_{IL}$	--	--	0.4	
<b>RESET Pin Electrical Characteristics</b>						
Output Low Voltage $\overline{\text{RESET}}$		$I_{\text{sink}} = 1\text{mA}, V_{\text{IN}} = 3.3\text{V to } 5.5\text{V}$	--	--	0.2	V
Output High Leakage $\overline{\text{RESET}}$		$T_A = 25^\circ\text{C}, V_{\text{IN}} = 3.3\text{V to } 5.5\text{V}$	-1	0	1	$\mu\text{A}$
		$T_A = 85^\circ\text{C}, V_{\text{IN}} = 3.3\text{V to } 5.5\text{V}$	--	0.1	--	

- Note 1.** Stresses beyond those listed under “Absolute Maximum Ratings” may cause permanent damage to the device. These are stress ratings only, and functional operation of the device at these or any other conditions beyond those indicated in the operational sections of the specifications is not implied. Exposure to absolute maximum rating conditions may affect device reliability.
- Note 2.**  $\theta_{JA}$  is measured at  $T_A = 25^\circ\text{C}$  on a high effective thermal conductivity four-layer test board per JEDEC 51-7.  $\theta_{JC}$  is measured at the exposed pad of the package.
- Note 3.** Devices are ESD sensitive. Handling precaution is recommended.
- Note 4.** The device is not guaranteed to function outside its operating conditions.
- Note 5.** Limits apply to the recommended operating temperature range of  $-40^\circ\text{C}$  to  $85^\circ\text{C}$ , unless otherwise noted. Minimum and maximum limits are verified through test, design, or statistical correlation. Typical values represent the most likely parametric norm at  $T_A = 25^\circ\text{C}$ , and are provided for reference purposes only. Unless otherwise stated the following conditions apply :  $V_{\text{IN}} = 3.3\text{V to } 5.5\text{V}$ .

## Typical Application Circuit

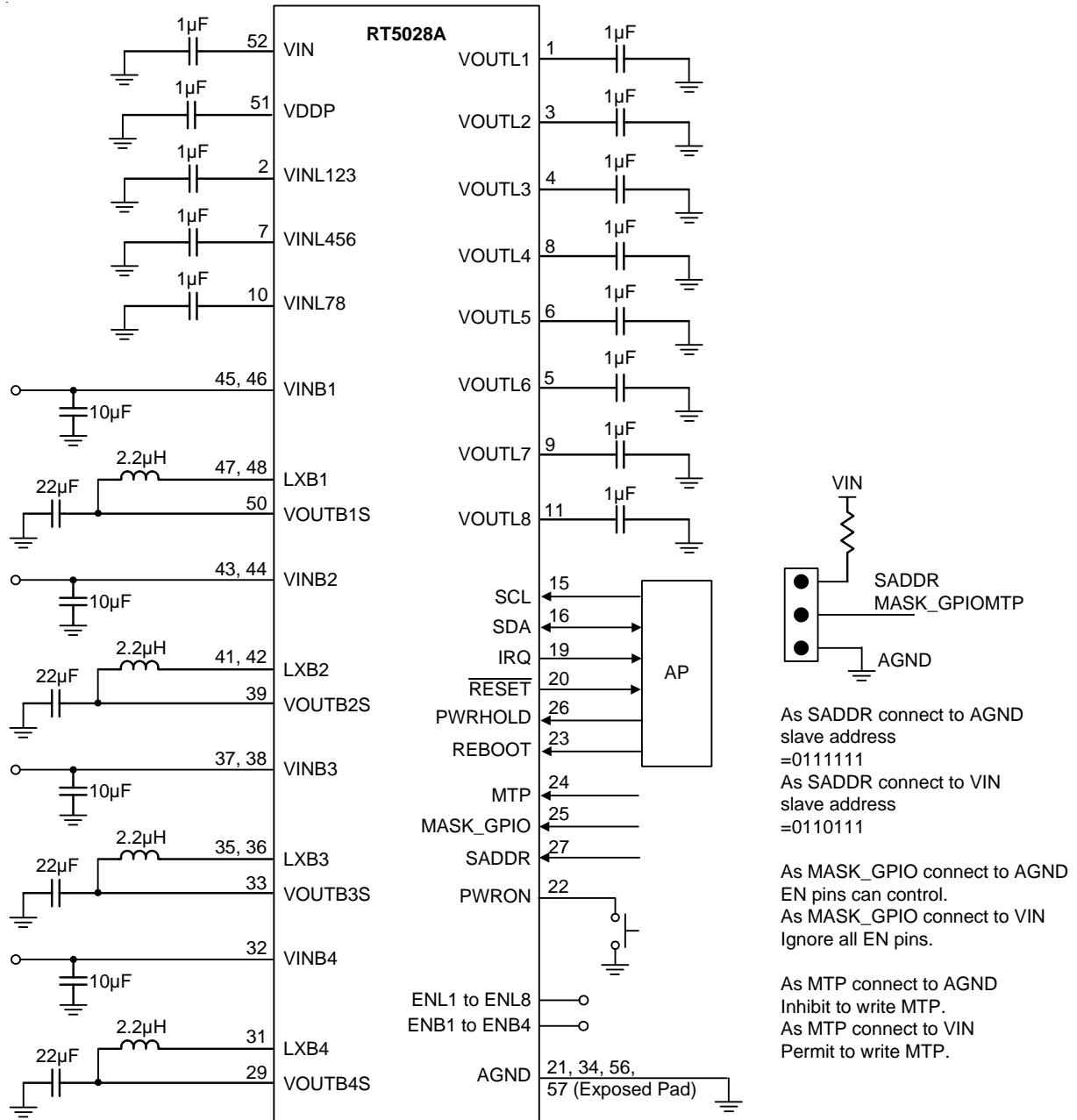

### Suggested Components for Typical Application Circuit

Description	P/N	Manufacturer
Inductor for Buck-2.2µH	LQH43PB2R2M26L	Murata
C <sub>IN</sub> for Buck-10µF	C1206X7R1E516DT	Murata
C <sub>OUT</sub> for Buck-22µF	C1206X7R22E416DT	Murata
C <sub>IN</sub> /C <sub>OUT</sub> for LDO-1µF	C0603X7R1E216DT	Murata

**Typical Operating Characteristics**

**CH1 Buck Efficiency vs. Output Current**

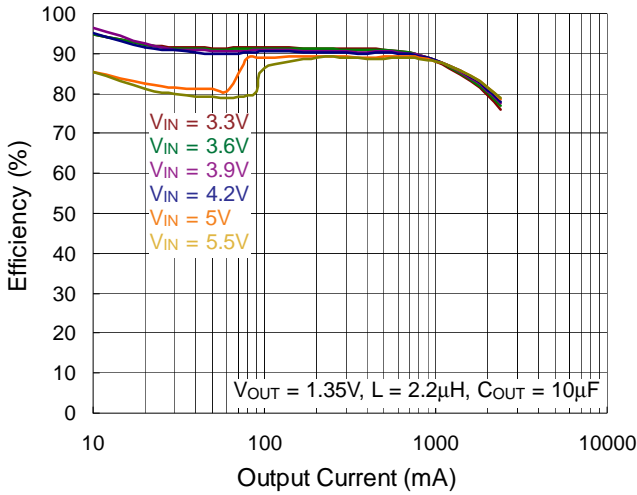

**CH2 Buck Efficiency vs. Output Current**

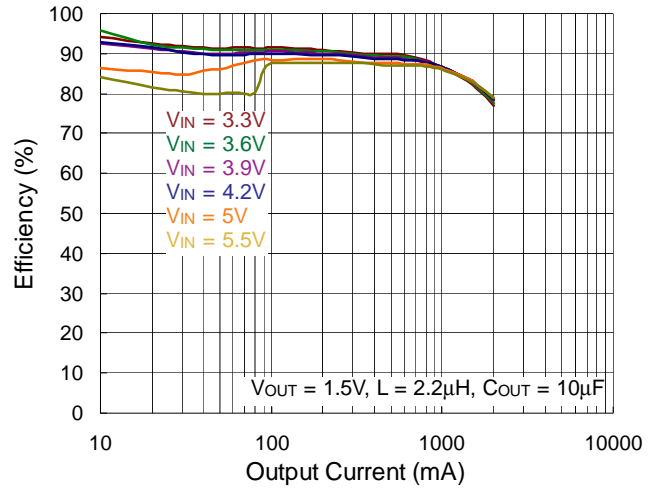

**CH3 Buck Efficiency vs. Output Current**

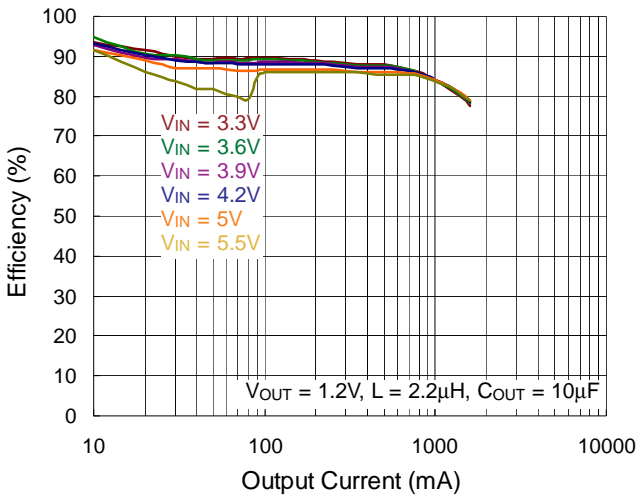

**CH4 Buck Efficiency vs. Output Current**

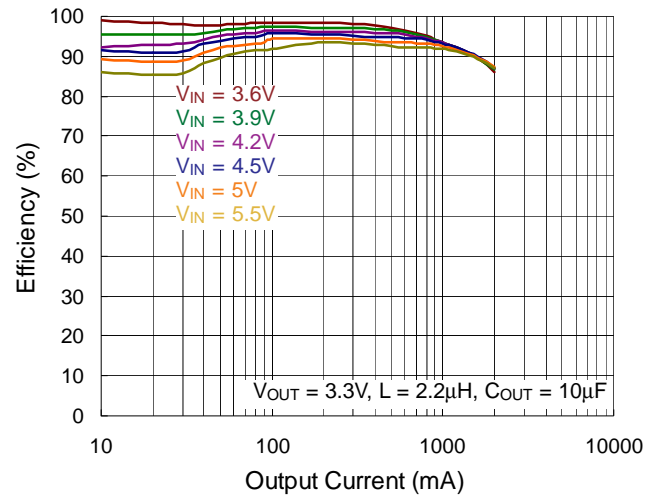

**CH1 Buck Output Voltage vs. Output Current**

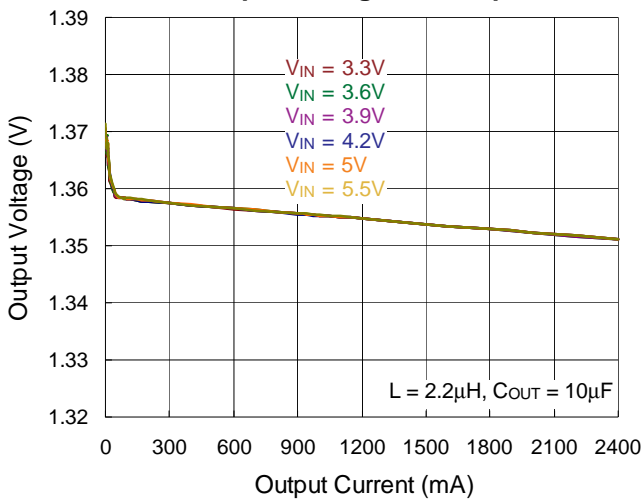

**CH2 Buck Output Voltage vs. Output Current**

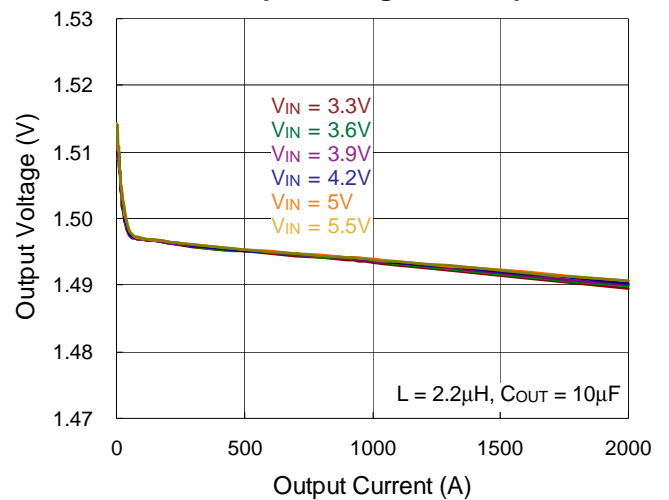

CH3 Buck Output Voltage vs. Output Current

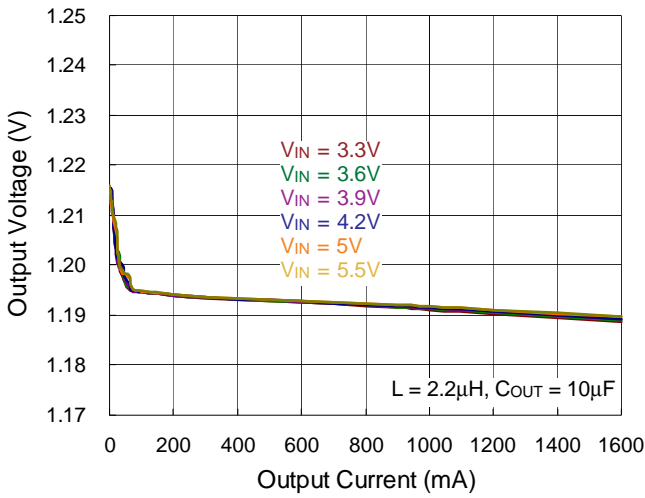

CH4 Buck Output Voltage vs. Output Current

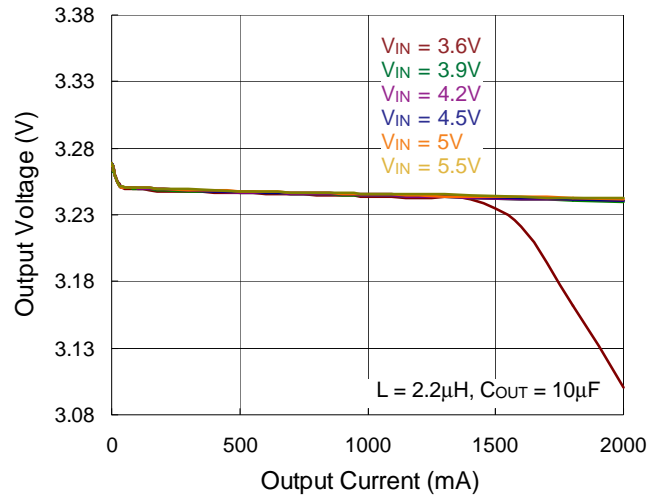

CH1 Buck Output Voltage vs. Input Voltage

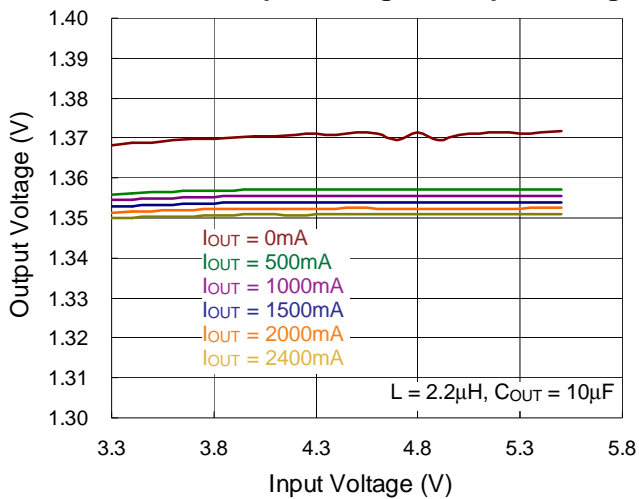

CH2 Buck Output Voltage vs. Input Voltage

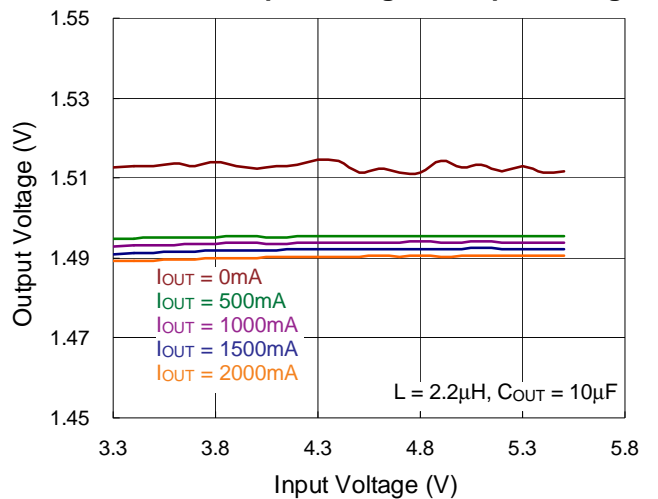

CH3 Buck Output Voltage vs. Input Voltage

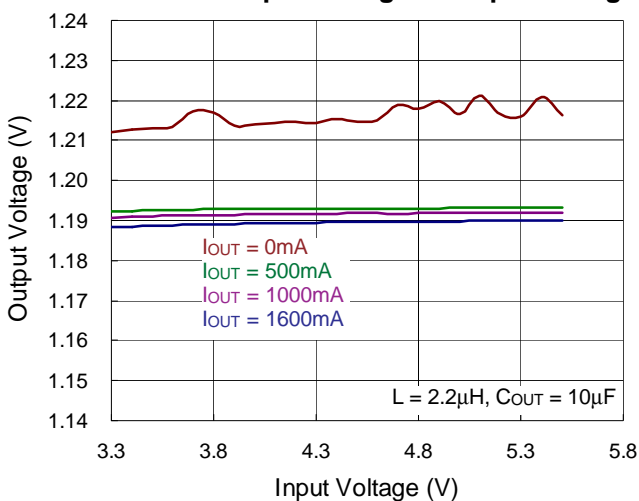

CH4 Buck Output Voltage vs. Input Voltage

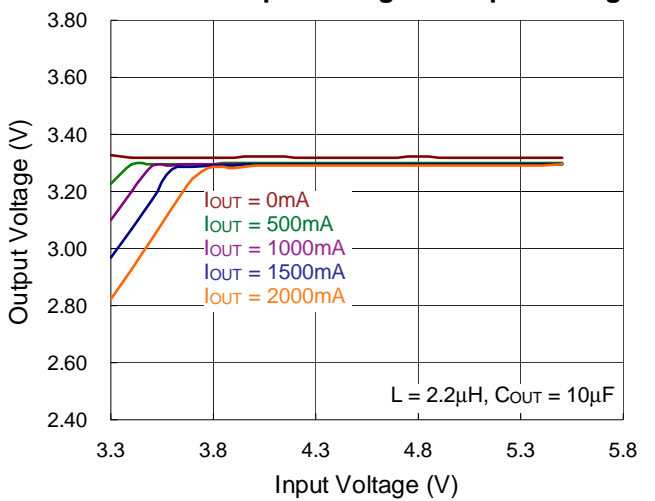

**LDO2 Output Voltage vs. Output Current**

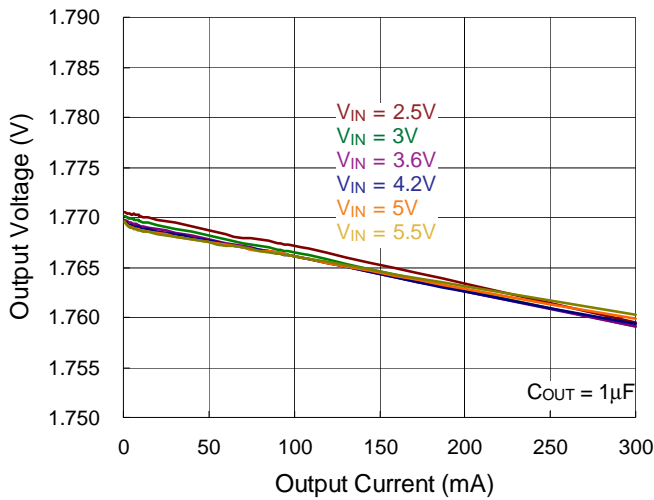

**LDO5 Output Voltage vs. Output Current**

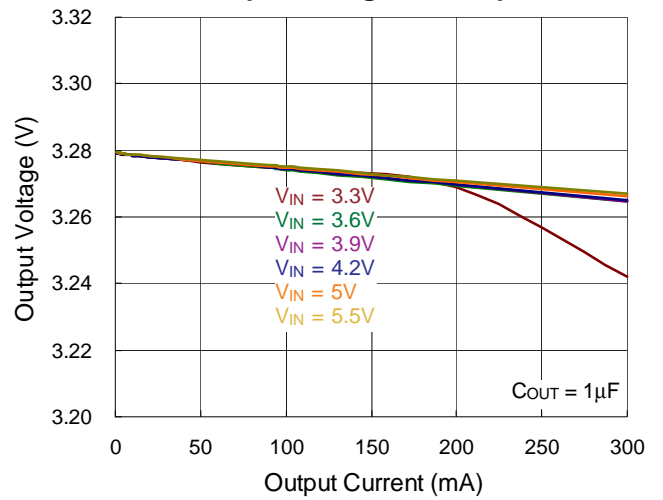

**LDO7 Output Voltage vs. Output Current**

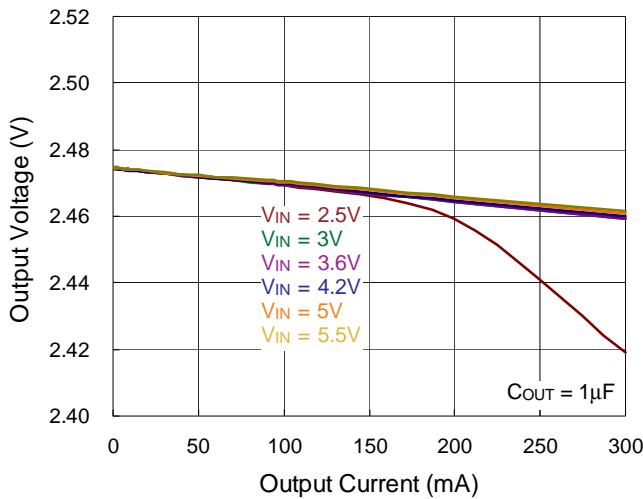

**LDO2 Output Voltage vs. Input Voltage**

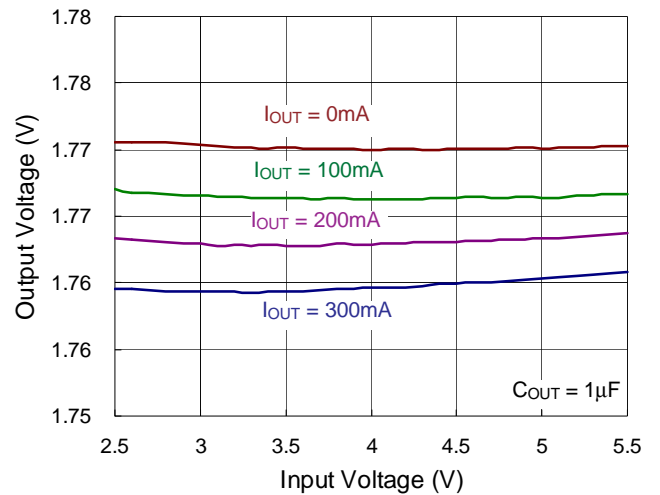

**LDO5 Output Voltage vs. Input Voltage**

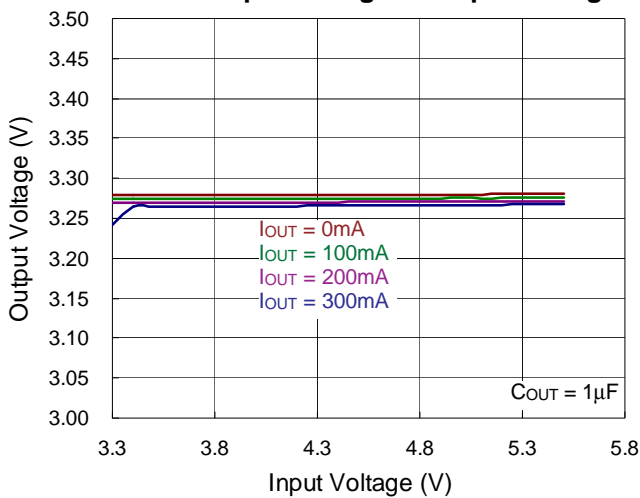

**LDO7 Output Voltage vs. Input Voltage**

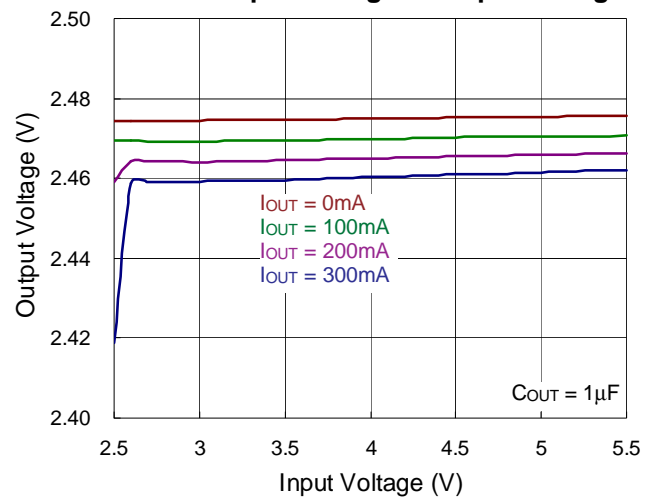

## Application Information

The RT5028A is a highly-integrated solution for automotive system including PMIC and memory system. The RT5028A application mechanism and I<sup>2</sup>C compatible interface are introduced in later sections. The system's slave address is 0110111 (As SADDR = high) or 0111111 (As SADDR = low).

PMIC - Power management system provides 8 low dropout linear regulator and 4 high efficiency synchronous step-down DC-DC converters. Power-On and Power-Off sequences are control by PWRON and  $\overline{\text{RESET}}$  input pins.

Detail time sequence control is described in Power ON/OFF diagram. The I<sup>2</sup>C interface can program individual regulator output voltage as well as on/off control and voltage setting.

### I<sup>2</sup>C Interface Timing Diagram

The RT5028A acts as an I<sup>2</sup>C -bus slave. The I<sup>2</sup>C-bus master configures the settings for all function blocks by sending command bytes to the RT5028A via the 2-wire I<sup>2</sup>C-bus. The I<sup>2</sup>C timing diagrams are list in the following.

Parameter	Symbol	Test Conditions	Min	Typ	Max	Unit
<b>I<sup>2</sup>C Interface Electrical Characteristics</b>						
SDA, SCLK Input High Level Threshold			0.7 x VDDP	--	--	V
SDA, SCLK Input Low Level Threshold			--	--	0.3 x VDDP	V
SCLK Clock Rate	f <sub>SCL</sub>		--	--	400	kHz
Hold Time (Repeated) START Condition. After this period, the first clock pulse is generated	t <sub>HD;STA</sub>		0.6	--	--	μs
LOW Period of the SCL Clock	t <sub>LOW</sub>		1.3	--	--	μs
HIGH Period of the SCL Clock	t <sub>HIGH</sub>		0.6	--	--	μs
Set-Up Time for a Repeated START Condition	t <sub>SU;STA</sub>		0.6	--	--	μs
Data Hold Time	t <sub>HD;DAT</sub>		0	--	0.9	μs
Data Set-Up Time	t <sub>SU;DAT</sub>		100	--	--	ns
Set-Up Time for STOP Condition	t <sub>SU;STO</sub>		0.6	--	--	μs
Bus Free Time Between a STOP and START Condition	t <sub>BUF</sub>		1.3	--	--	μs
Rise Time of Both SDA and SCL Signals	t <sub>R</sub>		20	--	300	ns
Fall Time of Both SDA and SCL Signals	t <sub>F</sub>		20	--	300	ns
SDA and SCL Output Low Sink Current	I <sub>OL</sub>	SDA or SCL voltage = 0.4V	2	--	--	mA

**Read Function**

Reading One Indexed Byte of Data from RT (With 1-Byte)

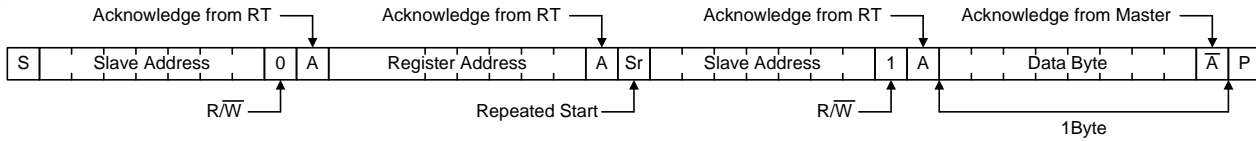

Reading n Indexed Words of Data from RT (With N-Byte)

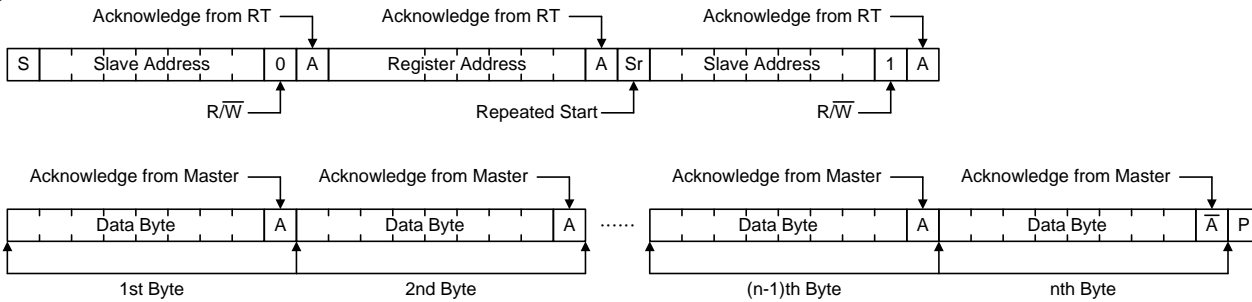

**Write Function**

Writing One Byte of Data to RT (With 1-Byte)

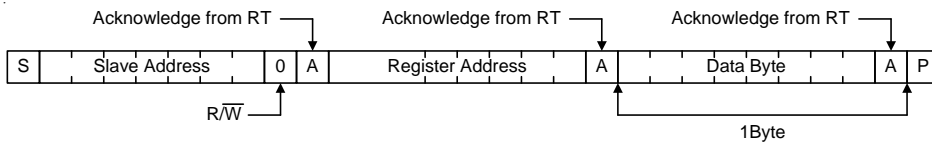

Writing n Bytes of Data to RT (With N-Byte)

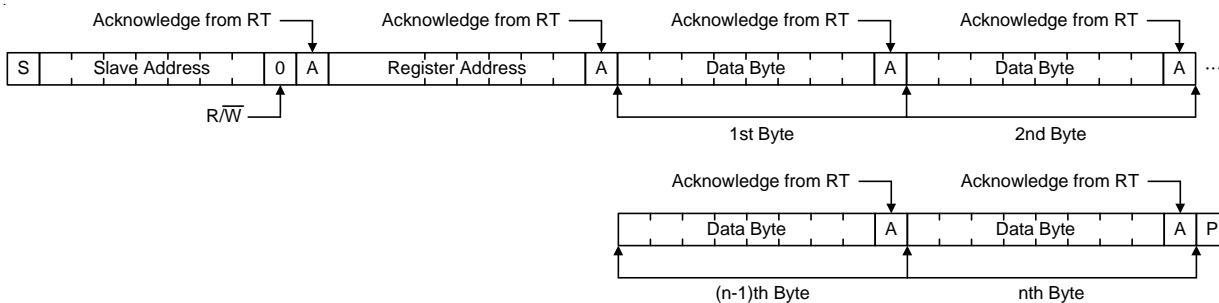

## PMIC

### Power Channels Control Methodology

When VIN power Good or PWRON event occurs, the PMIC will follow the power on sequence to turn on channels. During normal operation, users can use the REBOOT pin to restart PMIC again. Another PWROFF event, OTP or UVP occurs, PMIC will execute the power off. In the RT5028A PMIC, the UVP event will be set out when the Buck1 to Buck4s' output voltage is lower than  $1/2 \times (V_{OUT})$ .

### VIN Over-Voltage Protection

The device has a built-in OVP circuit which monitors the

input voltage. If the voltage exceeds the OVP threshold (typ value = 5.95V), the device stops operating. As soon as the voltage drops below the low threshold (typ value = 5.65V), the device starts to operate again. Therefore, over-voltage protection is implemented to prevent the input voltage from exceeding critical values to damage the device.

Base on ISO 7637 test case, if VIN vary violently, the device will trigger UVP or OVP (VIN rising up slew rate should be less than 5V/1ms) and then stops operating. The device needs to do power reset (VIN < 1.7V) to resume operation.

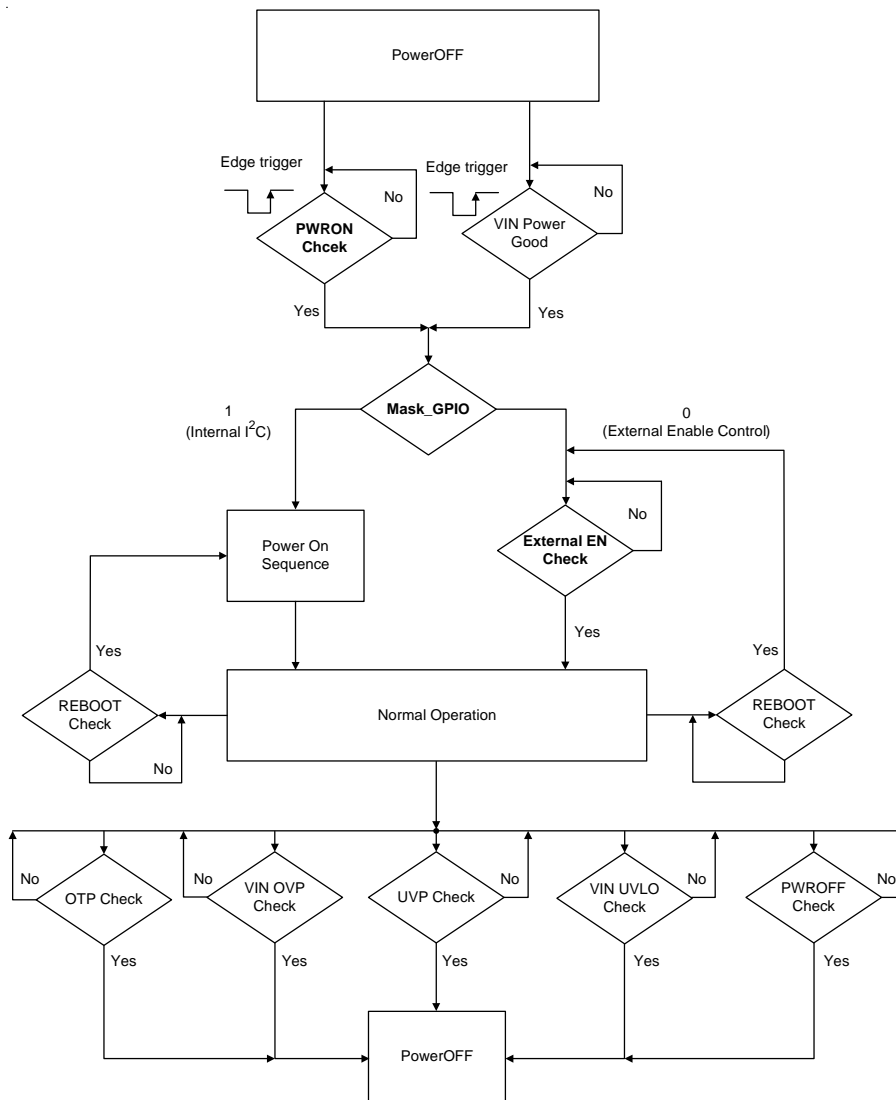

OTP function can be controlled by 0x16[2]  
 VOUT UVP function can be controlled by 0x16 [7:4]  
 VIN\_UVLO threshold can be controlled by 0x 0x12[7:5]

**PMIC - POWER ON/OFF Setting**

The circuit setting for communication between RT5028A and AP is showed as below.

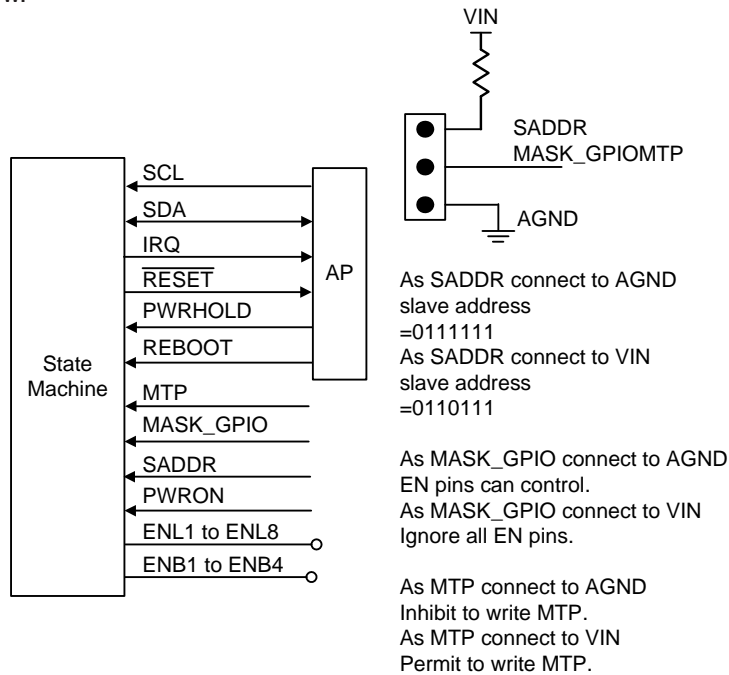

**RESET Pin**

The RESET comparator features an open drain output. The RESET pin pull high to input voltage with 10kΩ which slew rate define as follow.

**RESET Rising Slew Rate**

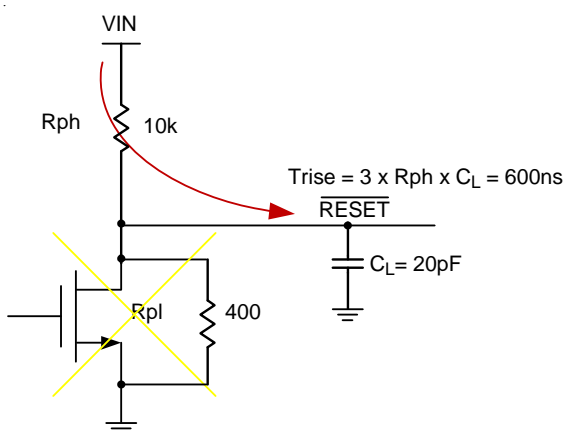

**RESET Falling Slew Rate**

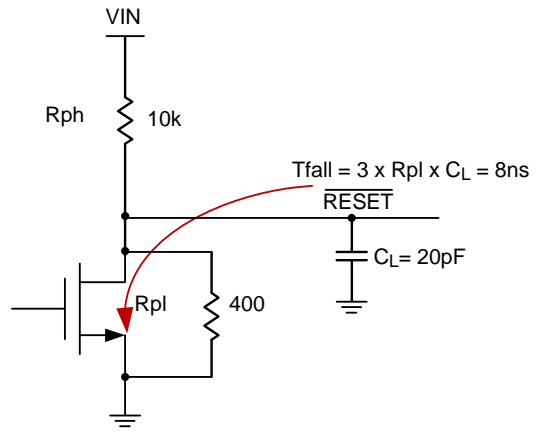

**GPIO Pin Pull-Up/Down Defined**

Pin No.	Pin Name	GPIO Pin Pull-Up/Down Defined	Resistor
12	ENL4	Internal 100kΩ pull low resistor	Internal
13	ENL5	Internal 100kΩ pull low resistor	Internal
14	ENL6	Internal 100kΩ pull low resistor	Internal
15	SCL	Open drain, need to connect 10kΩ pull up	External
16	SDA	Open drain, need to connect 10kΩ pull up	External
17	ENL7	Internal 100kΩ pull low resistor	Internal
18	ENL8	Internal 100kΩ pull low resistor	Internal
22	PWRON	Internal 100kΩ pull up resistor	Internal
23	REBOOT	Internal 100kΩ pull low resistor	Internal
24	MTP	Internal 100kΩ pull low resistor	Internal
26	PWRHOLD	Internal 100kΩ pull low resistor	Internal
27	SADDR	Internal 100kΩ pull low resistor	Internal
28	ENB4	Internal 100kΩ pull low resistor	Internal
30	ENB3	Internal 100kΩ pull low resistor	Internal
40	ENB2	Internal 100kΩ pull low resistor	Internal
49	ENB1	Internal 100kΩ pull low resistor	Internal
53	ENL1	Internal 100kΩ pull low resistor	Internal
54	ENL2	Internal 100kΩ pull low resistor	Internal
55	ENL3	Internal 100kΩ pull low resistor	Internal

**Power Hold Function**

When the “PWRHOLD” signal does not come during THOLD time, the RT5028A will do shutdown sequence.

If users want to disable power hold function, set “DisTHOLD” bit in I<sup>2</sup>C register 10 bit[0] to disable this function. In the timing diagram below, the “THOLD” and “RESET\_DLY” can be set by MTP program.

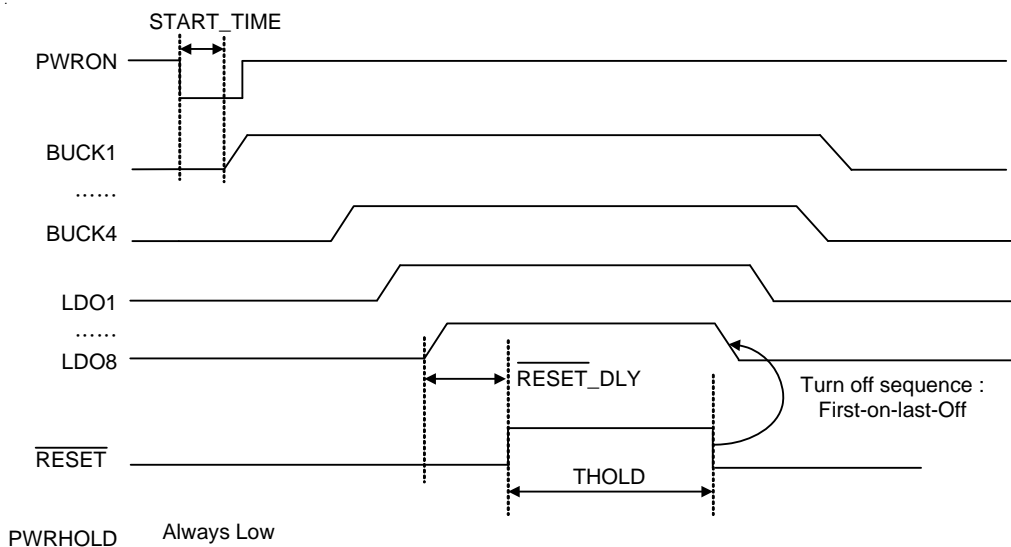

When AP sends the "PWRHOLD" signal during THOLD time, the RT5028A will keep power-on.

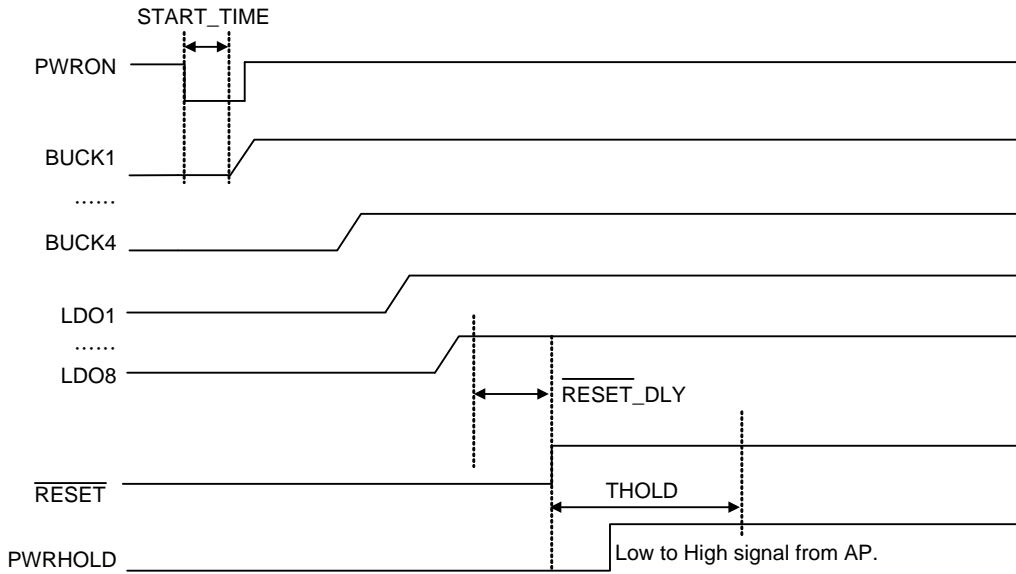

**Timing Based ON/OFF Sequence (PWRON\_NORMOFF\_EN, Reg0x15[0] = 1)**

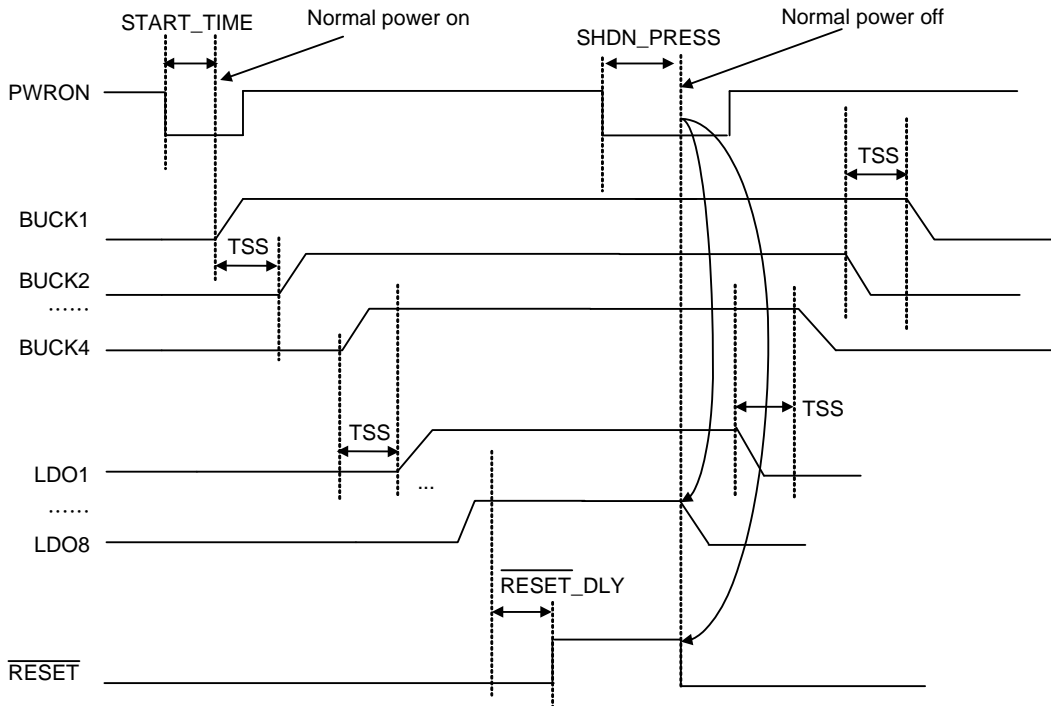

## Level Based ON/OFF Sequence (PWRON\_NORMOFF\_EN, Reg0x15[0] = 1)

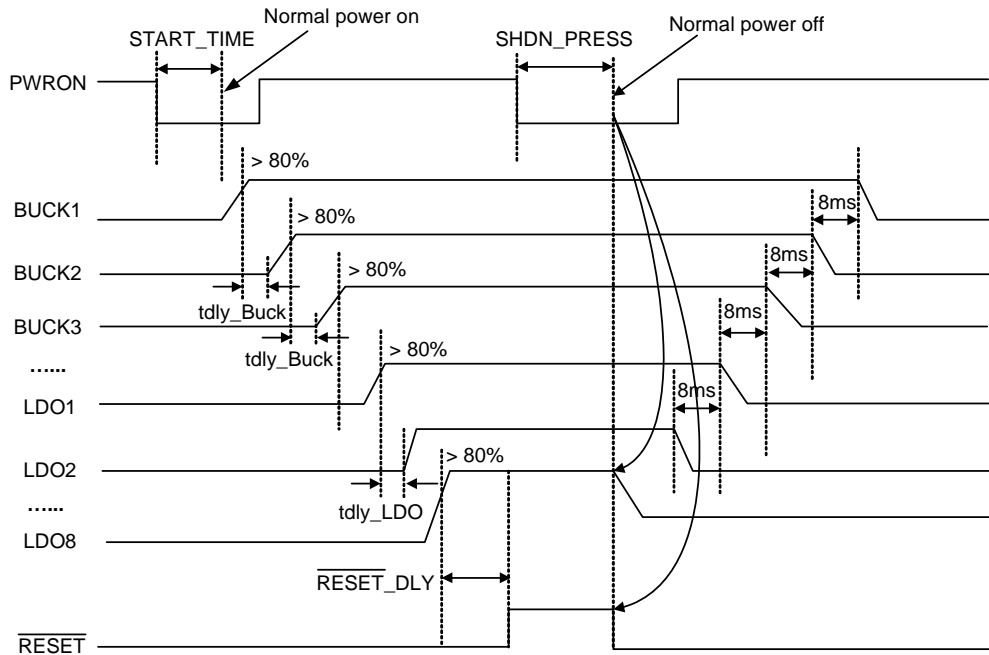

Note.

Sequence : BUCK1→BUCK2→BUCK3→BUCK4→LDO1→LDO2→LDO3→LDO4→LDO5→LDO6→LDO7→LDO8

$tdly\_Buck : 192 \times (1/fsw) + 40\mu s \pm 35\%$

$tdly\_LDO : 110\mu s \pm 20\%$  (If previous one channel is Buck, additional delay time  $32 \times (1/fsw)$  need to be added to  $tdly\_LDO$ .)

## Abnormal OFF (OTP, Buck 1/2/3/4 UVP)

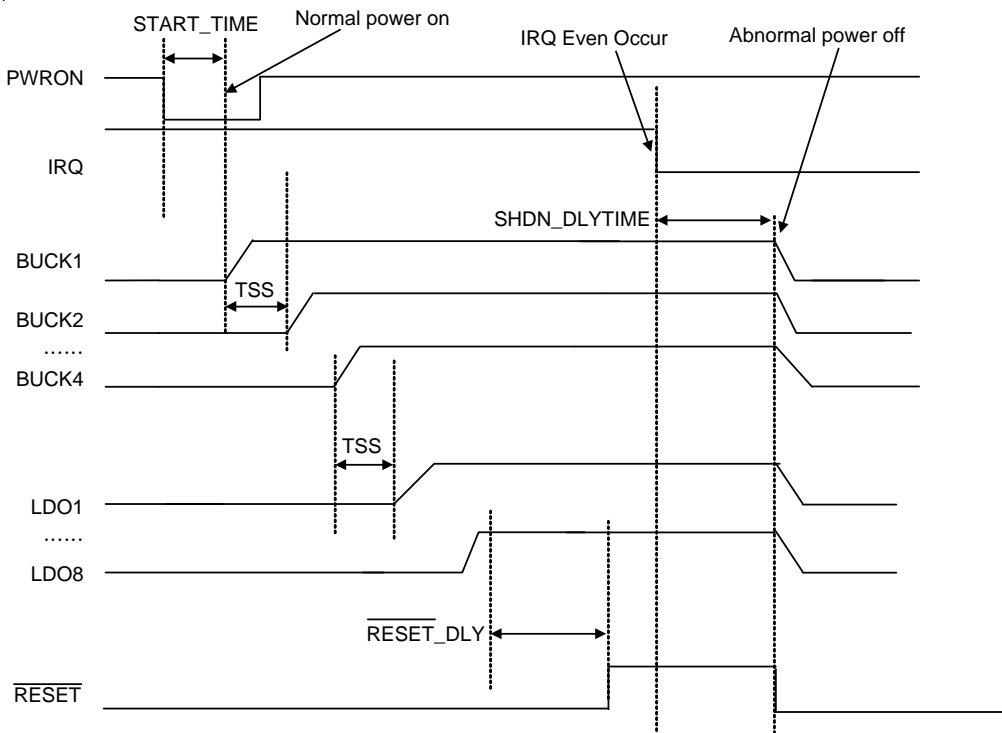

Based ON/OFF Sequence by VIN (VINLV\_ENSHDN, Reg0x16[1] = 0)

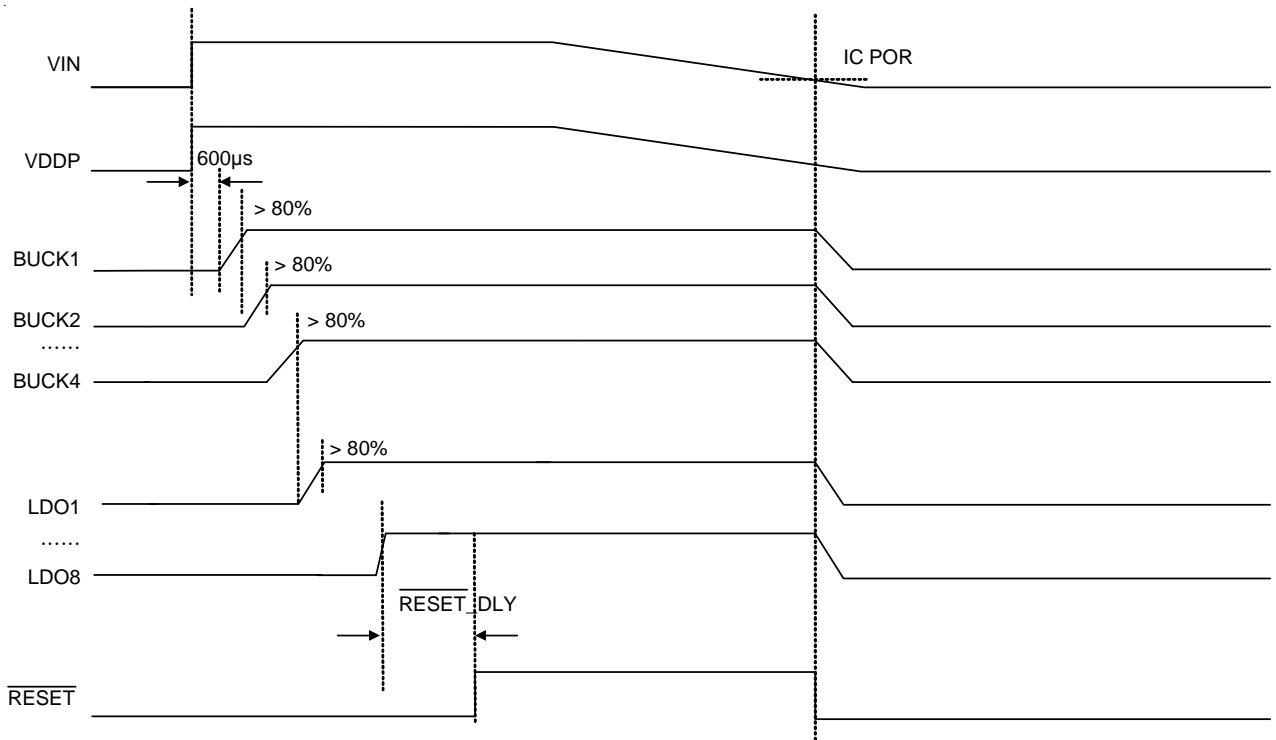

(VINLV\_ENSHDN, Reg0x16[1] = 1; VINLV\_SEQ\_EN, Reg0x16[0] = 1)

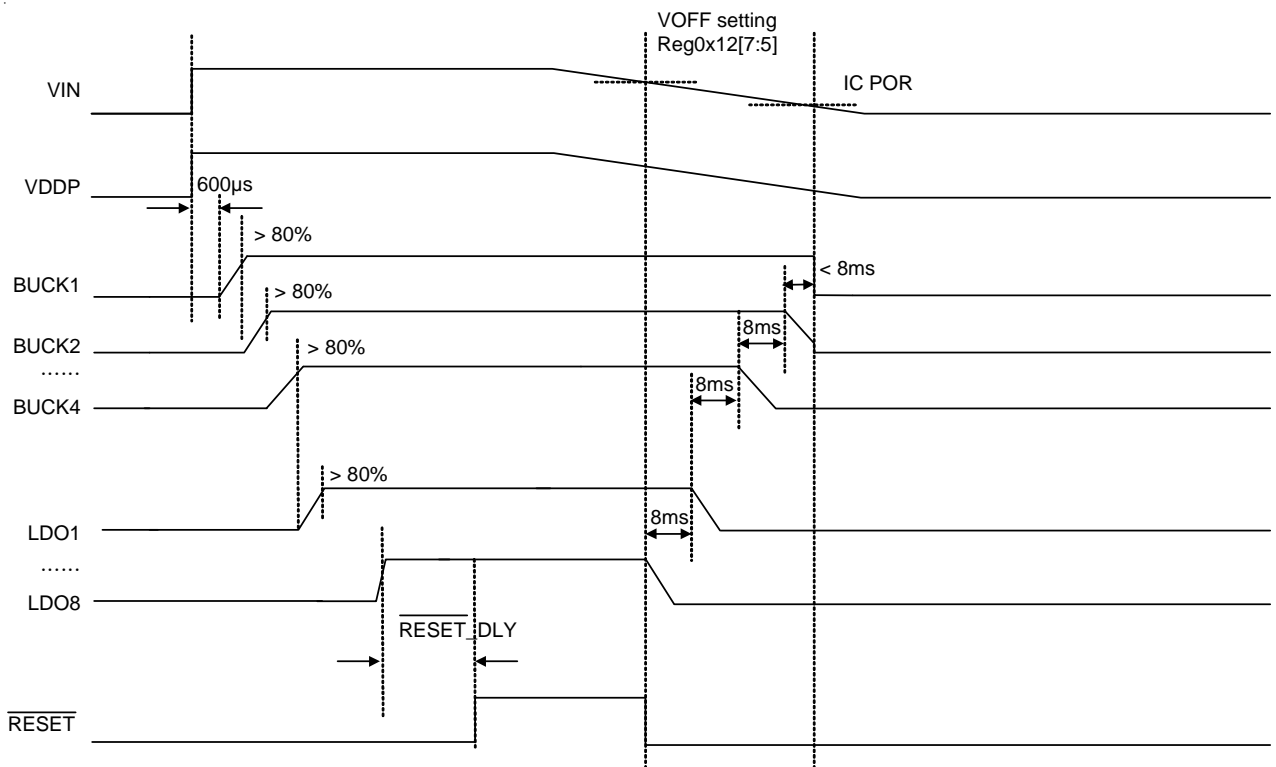

## PMU On/Off Sequence Setting

In the RT5028A, users can set the power on/off sequence and output voltage by I<sup>2</sup>C register 0x01 to 0x04 for Buck output voltage, 0x07 to 0x0E for LDO output voltage and 0x2C to 0x32 for startup sequence setting.

In the table below, users must set one by one (continues number) and missing code is not allowed.

If users miss sequence code, the RT5028A will wait for next channel and the IC will be hold in waiting status.

	Output Voltage Setting	Startup Sequence Setting	Startup Enable Method (Soft-Start Control)
Buck1	Buck1Output[5:0]	Buck1_Seq[3:0]	[10]
	[000000]	[0001]	
Buck2	Buck2Output[5:0]	Buck2_Seq[3:0]	
	[101100]	[0010]	
Buck3	Buck3Output[5:0]	Buck3_Seq[3:0]	
	[000000]	[0011]	
Buck4	Buck4Output[5:0]	Buck4_Seq[3:0]	
	[101100]	[0100]	
LDO1	LDO1OUT[6:0]	LDO1_Seq[3:0]	
	[0000000]	[0101]	
LDO2	LDO2OUT[6:0]	LDO2_Seq[3:0]	
	[0101000]	[0110]	
LDO3	LDO3OUT[6:0]	LDO3_Seq[3:0]	
	[0000000]	[0111]	
LDO4	LDO4OUT[6:0]	LDO4_Seq[3:0]	
	[0101000]	[1000]	
LDO5	LDO5OUT[6:0]	LDO5_Seq[3:0]	
	[0000000]	[1001]	
LDO6	LDO6OUT[6:0]	LDO6_Seq[3:0]	
	[0101000]	[1010]	
LDO7	LDO7OUT[6:0]	LDO7_Seq[3:0]	
	[0000000]	[1011]	
LDO8	LDO8OUT[6:0]	LDO8_Seq[3:0]	
	[0101000]	[1100]	

Note :

\* Output Voltage Setting: fill relative binary code to set the output voltage.

\* Startup Sequence Setting :

“0000” denotes no operation (disable).

“0001” denotes first-startup.

“1100 to 1111” denotes last-startup.

If same number, it means startup at the same time.

\*Startup Enable Method :

[01] to [11] : each startup enable interval time (1ms, 4ms, 8ms).

[00] : start end voltage (the output voltage's 80%)

**Synchronous Step-Down DC-DC Converter**

Four current mode synchronous step-down DC-DC converters operate with internal power MOSFETs and compensation network. These channels supply the power core chip of portable system. They can be operated at 100% maximum duty cycle to extend battery operating voltage range. When the input voltage is close to the output voltage, the converter enters low dropout mode with low output ripple. The operating frequency range of step-down converter is 0.5MHz to 2MHz.

Four step-down converters have RAMP control function as the following diagram.

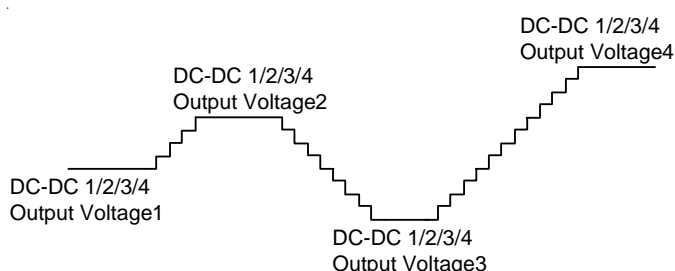

**Input and Output Capacitors Selection**

The RT5028A is designed to work with low ESR ceramic capacitors. The *effective* value of these capacitors is defined as the actual capacitance under voltage bias and temperature. All ceramic capacitors have a large voltage coefficient, in addition to normal tolerances and temperature coefficients. Under D.C. bias, the capacitance value drops considerably. Larger case sizes or higher voltage capacitors are better in this regard. To help mitigate these effects, multiple small capacitors can be used in parallel to bring the minimum effective capacitance up to the desired value.

The input capacitance,  $C_{IN}$ , is needed to filter the trapezoidal current at the source of the top MOSFET. A low ESR input capacitor with larger ripple current rating should be used for the maximum RMS current. RMS current is given by :

$$I_{RMS} = I_{OUT(MAX)} \times \frac{V_{OUT}}{V_{IN}} \times \sqrt{\frac{V_{IN}}{V_{OUT}} - 1}$$

This formula has a maximum at  $V_{IN} = 2V_{OUT}$ , where  $I_{RMS} = I_{OUT} / 2$ . This simple worst case condition is commonly used for design because even significant deviations do not offer much relief. Note that ripple current ratings from capacitor manufacturers are often based on only 2000 hours of life, which makes it advisable to either further derate the capacitor or choose a capacitor rated at a higher temperature than required. Several capacitors may also be placed in parallel to meet size or height requirements in the design. The selection of  $C_{OUT}$  is determined by the effective series resistance (ESR) that is required to minimize voltage ripple, load step transients, and the amount of bulk capacitance that is necessary to ensure that the control loop is stable. Loop stability can be examined by viewing the load transient response as described in a later section. The output ripple,  $\Delta V_{OUT}$ , is determined by :

$$\Delta V_{OUT} \leq \Delta I_L \left[ ESR + \frac{1}{8 \times f_{SW} \times C_{OUT}} \right]$$

The output ripple is highest at maximum input voltage since DIL increases with input voltage. Multiple capacitors placed in parallel may be needed to meet the ESR and RMS current handling requirements. Dry tantalum, special polymer, aluminum electrolytic and ceramic capacitors are all available in surface mount packages. Special polymer capacitors offer very low ESR but have lower capacitance density than other types. Tantalum capacitors have the highest capacitance density but it is important to only use types that have been surge tested for use in switching power supplies. Aluminum electrolytic capacitors have significantly higher ESR but can be used in cost-sensitive applications provided that consideration is given to ripple current ratings and long-term reliability. Ceramic capacitors have excellent low ESR characteristics but can have a high voltage coefficient and audible piezoelectric effects. The high Q of ceramic capacitors with trace inductance can also lead to significant ringing.

## Using Ceramic Input and Output Capacitors

Higher values, lower cost ceramic capacitors are now becoming available in smaller case sizes. Their high ripple current, high voltage rating and low ESR make them ideal for switching regulator applications. However, care must be taken when these capacitors are used at the input and output. When a ceramic capacitor is used at the input and the power is supplied by a wall adapter through long wires, a load step at the output can induce ringing at the input,  $V_{IN}$ . At best, this ringing can couple to the output and be mistaken as loop instability. At worst, a sudden inrush of current through the long wires can potentially cause a voltage spike at  $V_{IN}$  large enough to damage the part. Page 8 shows the nominal values of input/output capacitance recommended for the RT5028A.

## Inductor Selection

For a given input and output voltage, the inductor value and operating frequency determine the ripple current. The ripple current  $\Delta I_L$  increases with higher  $V_{IN}$  and decreases with higher inductance :

$$\Delta I_L = \left[ \frac{V_{OUT}}{f_{OSC} \times L} \right] \times \left[ 1 - \frac{V_{OUT}}{V_{IN}} \right]$$

Having a lower ripple current reduces the ESR losses in the output capacitors and the output voltage ripple. Highest efficiency operation is achieved at low frequency with small ripple current. This, however, requires a large inductor. A reasonable starting point for selecting the ripple current is  $\Delta I_L = 0.4 (I_{MAX})$ . The largest ripple current occurs at the highest  $V_{IN}$ . To guarantee that the ripple current stays below a specified maximum, the inductor value should be chosen according to the following equation :

$$L = \left[ \frac{V_{OUT}}{f_{OSC} \times \Delta I_L(MAX)} \right] \times \left[ 1 - \frac{V_{OUT}}{V_{IN(MAX)}} \right]$$

## Inductor Core Selection

Once the value for L is known, the type of inductor must be selected. High efficiency converters generally cannot afford the core loss found in low cost powdered iron cores, forcing the use of more expensive ferrite or permalloy cores. Actual core loss is independent of core size for a fixed inductor value but it is very dependent on the inductance

selected. As the inductance increases, core losses decrease. However, increased inductance requires more turns of wire and therefore copper losses will increase.

Ferrite designs have very low core losses and are preferred at high switching frequencies, so design goals can concentrate on copper loss and preventing saturation.

Ferrite core material saturates "hard" which means that inductance collapses abruptly when the peak design current is exceeded.

This results in an abrupt increase in inductor ripple current and consequent output voltage ripple.

Do not allow the core to saturate!

Different core materials and shapes will change the size/current and price/current relationship of an inductor. Toroid or shielded pot cores in ferrite or permalloy materials are small and don't radiate energy but generally cost more than powdered iron core inductors with similar characteristics. The choice of which style inductor to use mainly depend on the price vs. size requirements and any radiated field/EMI requirements.

## REBOOT Function

As the REBOOT pin is set from low to high, the REBOOT function will be active. The REBOOT's FSM is shown as below. It concludes 100ms de-bouncing time and delay1/delay2 power off delay time.

**Table 1. REBOOT Input Control Setting**

	Description	Default
delayed2	00 : 100ms    10 : 1s	Option
delayed1	01 : 500ms    11 : 2s	Option
Action	delayed1 power-off then delayed2 power-on PMIC	

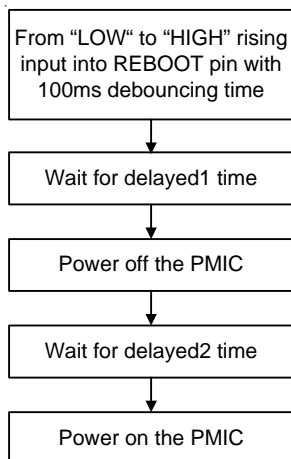

**IRQ Table**

We summarize all IRQ items in the register table. All IRQ\_status registers are implemented as reset after read. If IRQ\_enable bit is Low, the IRQ\_status bit will not update status. IRQ\_enable will mask IRQ\_status to trigger IRQ\_PMIC Low, so the system can decide which interrupt is necessary.

**Waveform - (when the other IRQ\_status are low)**

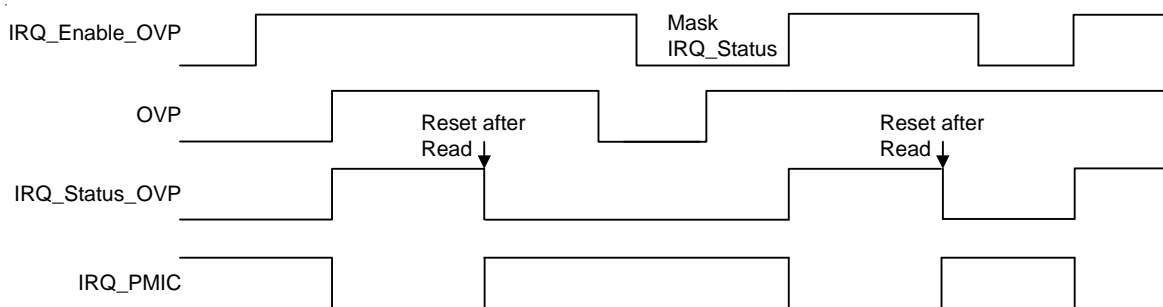

**Waveform - (when the other IRQ\_status are low)**

\* OTW125/OTW100 means the 125°C/100°C pre-warming over-temperature.

**EEPROM (MTP) Control Flow**

The RT5028A embeds 32 bytes MTP memory, and it allows users to save some I<sup>2</sup>C register bank data to MTP. When the I<sup>2</sup>C register 0x3A Bit[0]/Bit[1] is wrote to "1", the MTP Page1/Page2 will execute erase process firstly.

Because the erase process will be done in every writing time, the MTP data will be missed. So it would be best for users to read data from MTP to I<sup>2</sup>C first before executing writing process.

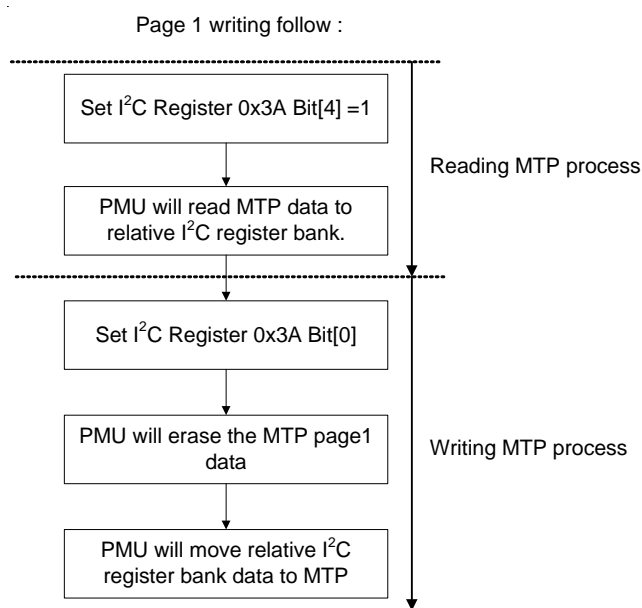

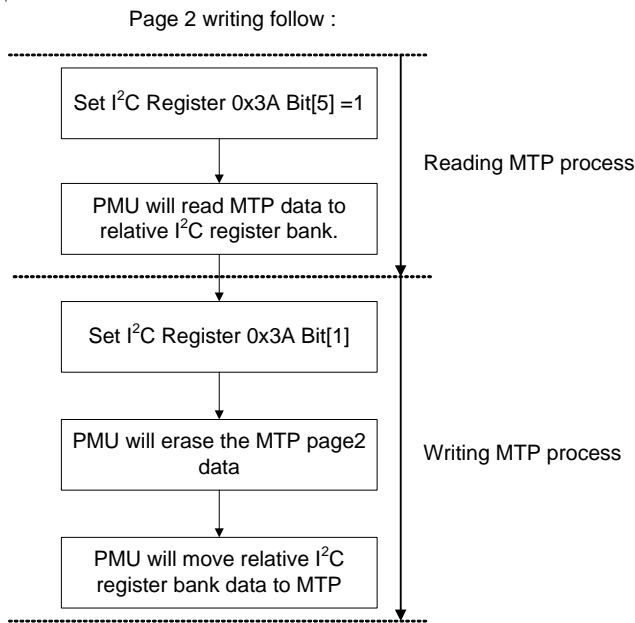

**Thermal Considerations**

For continuous operation, do not exceed absolute maximum junction temperature. The maximum power dissipation depends on the thermal resistance of the IC package, PCB layout, rate of surrounding airflow, and difference between junction and ambient temperature. The maximum power dissipation can be calculated by the following formula :

$$P_{D(MAX)} = (T_{J(MAX)} - T_A) / \theta_{JA}$$

where  $T_{J(MAX)}$  is the maximum junction temperature,  $T_A$  is the ambient temperature, and  $\theta_{JA}$  is the junction to ambient thermal resistance.

For recommended operating condition specifications, the maximum junction temperature is 125°C. The junction to ambient thermal resistance,  $\theta_{JA}$ , is layout dependent. For WQFN-56L 7x7 package, the thermal resistance,  $\theta_{JA}$ , is 27°C/W on a standard JEDEC 51-7 four-layer thermal test board. The maximum power dissipation at  $T_A = 25^\circ\text{C}$  can be calculated by the following formula :

$$P_{D(MAX)} = (125^\circ\text{C} - 25^\circ\text{C}) / (27^\circ\text{C/W}) = 3.7\text{W for WQFN-56L 7x7 package}$$

The maximum power dissipation depends on the operating ambient temperature for fixed  $T_{J(MAX)}$  and thermal resistance,  $\theta_{JA}$ . The derating curve in Figure 1 allows the designer to see the effect of rising ambient temperature on the maximum power dissipation.

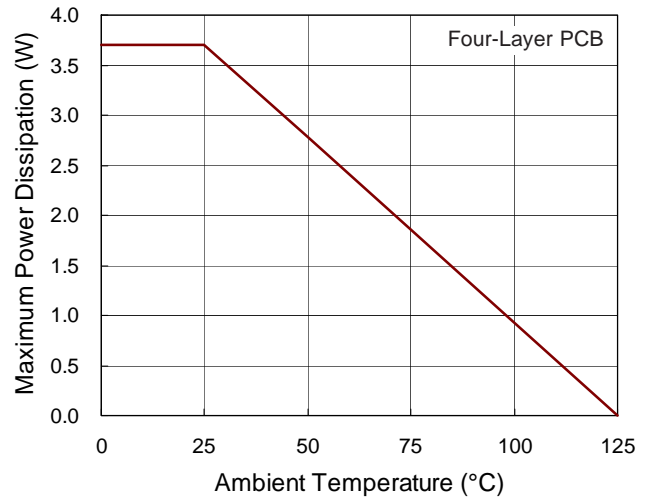

Figure 1. Derating Curve of Maximum Power Dissipation

**Layout Considerations**

For the best performance of the RT5028A, the following PCB layout guidelines must be strictly followed.

- ▶ Place the input and output capacitors as close as possible to the input and output pins respectively for good filtering.
- ▶ Keep the main power traces as wide and short as possible.
- ▶ The switching node area connected to LX and inductor should be minimized for lower EMI.
- ▶ Connect the GND and Exposed Pad to a strong ground plane for maximum thermal dissipation and noise protection.
- ▶ Directly connect the output capacitors to the feedback network of each channel to avoid bouncing caused by parasitic resistance and inductance from the PCB trace.

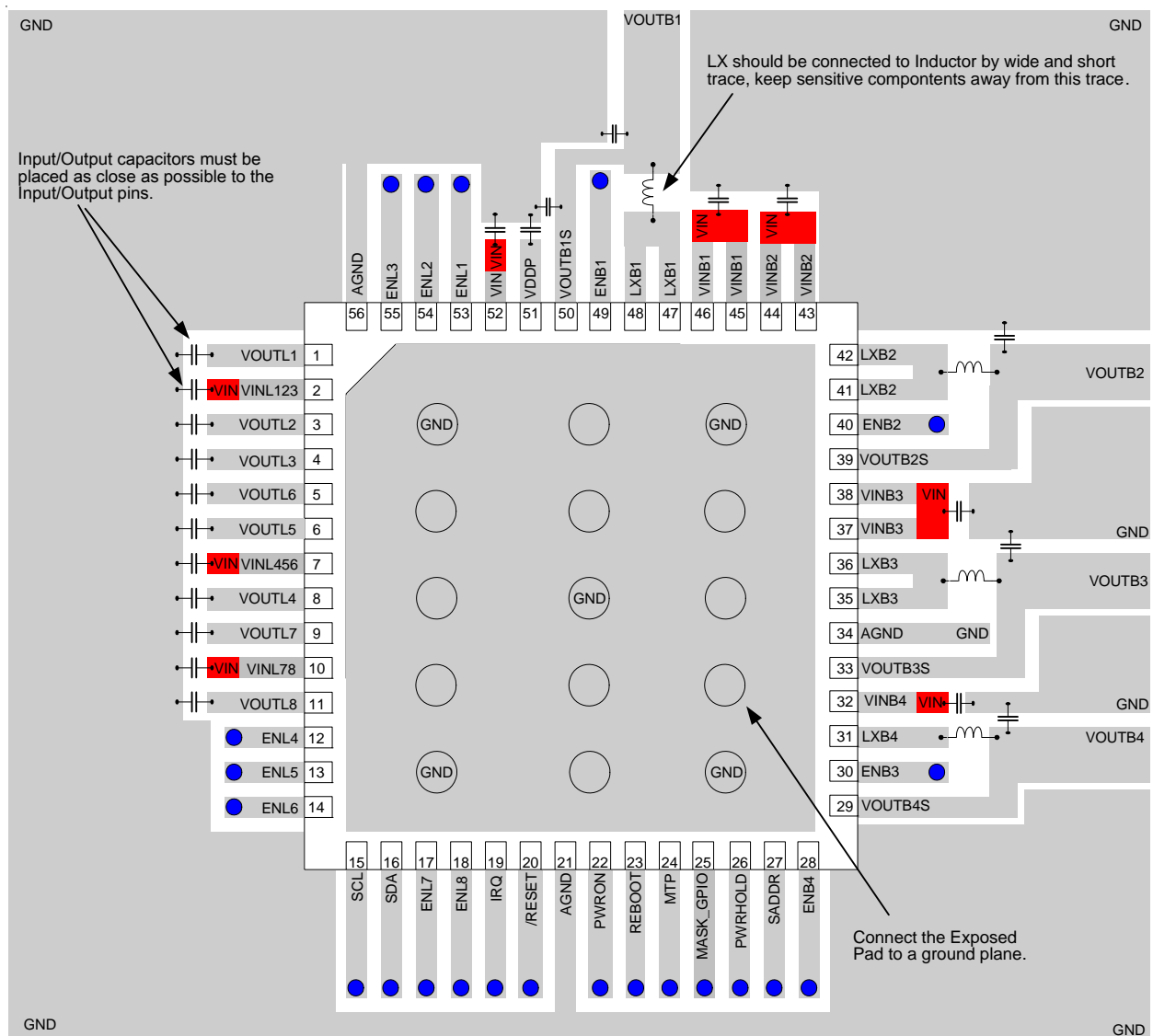

Figure 2. PCB Layout Guide

Table 2. I<sup>2</sup>C Register Table

Detail Description				
Address	00	Device ID		
Bit	Name	Description	Read/Write	Reset Value
[7:4]	VENDOR_ID	Vendor Identification : Richtek : 1000b	R	1000
[3:0]	CHIP_REV	Chip Revision	R	0101
Address	01	BUCKcontrol1		
Bit	Name	Description	R/W	Reset Value
[7:2]	Buck1Output[5:0]	Buck1 output voltage regulation 000000 : 0.7V, 25mV per step 000001 : 0.725V ... 101100 : 1.8V ... 111111 : 1.8V	R/W	Option
[1:0]	Buck1VRC	VRC setting 00 : 25mV/10μs, 01 : 50mV/10μs, 10 : 100mV/10μs, 11 : 200mV/10μs	R/W	Option
Address	02	BUCKcontrol2		
Bit	Name	Description	R/W	Reset Value
[7:2]	Buck2Output[5:0]	Buck2 output voltage regulation 000000 : 0.7V, 25mV per step 000001 : 0.725V ... 101100 : 1.8V ... 111111 : 1.8V	R/W	Option
[1:0]	Buck2VRC	VRC setting 00 : 25mV/10μs, 01 : 50mV/10μs, 10 : 100mV/10μs, 11 : 200mV/10μs	R/W	Option
Address	03	BUCKcontrol3		
Bit	Name	Description	R/W	Reset Value
[7:2]	Buck3Output[5:0]	Buck3 output voltage regulation 000000 : 0.7V, 50mV per step 000001 : 0.75V ... 111010 : 3.6V ... 111111 : 3.6V	R/W	Option
[1:0]	Buck3VRC	VRC setting 00 : 50mV/10μs, 01 : 100mV/10μs, 10 : 200mV/10μs, 11 : 400mV/10μs	R/W	Option

Address	04	BUCKcontrol4		
Bit	Name	Description	R/W	Reset Value
[7:2]	Buck4Output[5:0]	Buck4 output voltage regulation 000000 : 0.7V, 50mV per step 000001 : 0.75V ... 111010 : 3.6V ... 111111 : 3.6V	R/W	Option
[1:0]	Buck4VRC	VRC setting 00 : 50mV/10μs, 01 : 100mV/10μs, 10 : 200mV/10μs, 11 : 400mV/10μs	R/W	Option
Address	05	VRC Control		
Bit	Name	Description	R/W	Reset Value
7	Buck1VRC_EN	Buck1 VRC 0 : disable - voltage ramps up to target voltage with one time 1 : enable - voltage ramps up to target voltage with slope control	R/W	Option
6	Buck2VRC_EN	Buck2 VRC 0 - disable - voltage ramps up to target voltage with one time 1 - enable - voltage ramps up to target voltage with slope control	R/W	Option
5	Buck3VRC_EN	Buck3 VRC 0 : disable - voltage ramps up to target voltage with one time 1 : enable - voltage ramps up to target voltage with slope control	R/W	Option
4	Buck4VRC_EN	Buck4 VRC 0 : disable - voltage ramps up to target voltage with one time 1 : enable - voltage ramps up to target voltage with slope control	R/W	Option
[3:0]	Reserved		R/W	0000
Address	06	BUCK Mode		
Bit	Name	Description	R/W	Reset Value
7	Buck1mode	Buck1 mode 0 : Force PWM 1 : Auto Mode (PSM/PWM)	R/W	Option
6	Buck2mode	Buck2 mode 0 : Force PWM 1 : Auto Mode (PSM/PWM)	R/W	Option
5	Buck3mode	Buck3 mode 0 : Force PWM 1 : Auto Mode (PSM/PWM)	R/W	Option

4	Buck4mode	Buck4 mode 0 : Force PWM 1 : Auto Mode (PSM/PWM)	R/W	Option
3	Buck1oms	Buck1 output off mode state 0 : floating 1 : Ground-discharged, discharge resistance = 1010Ω (Typical)	R/W	Option
2	Buck2oms	Buck2 output off mode state 0 : floating 1 : Ground-discharged, discharge resistance = 1010Ω (Typical)	R/W	Option
1	Buck3oms	Buck3 output off mode state 0 : floating 1 : Ground-discharged, discharge resistance = 1010Ω (Typical)	R/W	Option
0	Buck4oms	Buck4 output off mode state 0 : floating 1 : Ground-discharged, discharge resistance = 1010Ω (Typical)	R/W	Option
Address	07	LDOcontrol1		
Bit	Name	Description	R/W	Reset Value
7	Reserved		R/W	0
[6:0]	LDO1OUT[6:0]	LDO1 output voltage regulation 0000000 : 1.6V, 25mV per step 0000001 : 1.625V ... 1100000 : 3.6V (MAX) ... 1111111 : 3.6V (MAX)	R/W	Option
Address	08	LDOcontrol2		
Bit	Name	Description	R/W	Reset Value
7	Reserved		R/W	0
[6:0]	LDO2OUT[6:0]	LDO2 output voltage regulation 0000000 : 1.6V, 25mV per step 0000001 : 1.625V ... 1100000 : 3.6V (MAX) ... 1111111 : 3.6V (MAX)	R/W	Option
Address	09	LDOcontrol3		
Bit	Name	Description	R/W	Reset Value
7	Reserved		R/W	0
[6:0]	LDO3OUT[6:0]	LDO3 output voltage regulation 0000000 : 1.6V, 25mV per step 0000001 : 1.625V ... 1100000 : 3.6V (MAX) ... 1111111 : 3.6V (MAX)	R/W	Option

Address	0A	LDOcontrol4		
Bit	Name	Description	R/W	Reset Value
7	Reserved		R/W	0
[6:0]	LDO4OUT[6:0]	LDO4 output voltage regulation 0000000 : 3 V, 25mV per step 0000001 : 3.025V ... 0011000 : 3.6V (MAX) ... 1111111 : 3.6V (MAX)	R/W	Option
Address	0B	LDOcontrol5		
Bit	Name	Description	R/W	Reset Value
7	Reserved		R/W	0
[6:0]	LDO5OUT[6:0]	LDO5 output voltage regulation 0000000 : 3V, 25mV per step 0000001 : 3.025V ... 0011000 : 3.6V (MAX) ... 1111111 : 3.6V (MAX)	R/W	Option
Address	0C	LDOcontrol6		
Bit	Name	Description	R/W	Reset Value
7	Reserved		R/W	0
[6:0]	LDO6OUT[6:0]	LDO6 output voltage regulation 0000000 : 3.0V, 25mV per step 0000001 : 3.025V ... 0011000 : 3.6V (MAX) ... 1111111 : 3.6V (MAX)	R/W	Option
Address	0D	LDOcontrol7		
Bit	Name	Description	R/W	Reset Value
7	Reserved		R/W	0
[6:0]	LDO7UT[6:0]	LDO7output voltage regulation 0000000 : 1.6V, 25mV per step 0000001 : 1.625V ... 1100000 : 3.6V (MAX) ... 1111111 : 3.6V (MAX)	R/W	Option

Address	0E	LDOcontrol8		
Bit	Name	Description	R/W	Reset Value
7	Reserved		R/W	0
[6:0]	LDO8T[6:0]	LDO8 output voltage regulation 0000000 : 1.6V, 25mV per step 0000001 : 1.625V ... 1100000 : 3.6V (MAX) ... 1111111 : 3.6V (MAX)	R/W	Option
Address	0F	LDOs off mode state		
Bit	Name	Description	R/W	Reset Value
7	LDO8oms	LDO8 output off mode state 0 : floating 1 : Ground-discharged, discharge resistance = 15Ω (Typical)	R/W	1
6	LDO7oms	LDO7 output off mode state 0 : floating 1 : Ground-discharged, discharge resistance = 15Ω (Typical)	R/W	1
5	LDO6oms	LDO6 output off mode state 0 : floating 1 : Ground-discharged, discharge resistance = 15Ω (Typical)	R/W	1
4	LDO5oms	LDO5 output off mode state 0 : floating 1 : Ground-discharged, discharge resistance = 15Ω (Typical)	R/W	1
3	LDO4oms	LDO4 output off mode state 0 : floating 1 : Ground-discharged, discharge resistance = 15Ω (Typical)	R/W	1
2	LDO3oms	LDO3 output off mode state 0 : floating 1 : Ground-discharged, discharge resistance = 15Ω (Typical)	R/W	1
1	LDO2oms	LDO2 output off mode state 0 : floating 1 : Ground-discharged, discharge resistance = 15Ω (Typical)	R/W	1
0	LDO1ms	LDO1 output off mode state 0 : floating 1 : Ground-discharged, discharge resistance = 15Ω (Typical)	R/W	1

Address	10	REBOOT/PWRHOLD delay time control		
Bit	Name	Description	R/W	Reset Value
[7:6]	Delayed2[1:0]	Delayed2 setting (00 : 100ms/01 : 500ms/10 : 1s/11 : 2s)	R/W	Option
[5:4]	Delayed1[1:0]	Delayed1 setting (00 : 100ms/01 : 500ms/10 : 1s/11 : 2s)	R/W	Option
[3:2]	THOLD[1:0]	THOLD setting (00 : 100ms/01 : 500ms/10 : 1s/11 : 2s)	R/W	Option
1	Reserved		R/W	0
0	DisTHOLD	Ignore THOLD Time. 0 : Keep PWRHOLD function. 1 : Ignore PWRHOLD function.	R/W	Option
Address	11	ON Event Setting		
Bit	Name	Description	R/W	Reset Value
[7:5]	On_Event	Powered on because of 000 : PWRON key-pressed 001 : VIN plugged in 010 : from REBOOT pin event 111 : No event happen	R	111
[4:0]	Reserved		R/W	0
Address	12	VIN UVLO/Buck On/Off		
Bit	Name	Description	R/W	Reset Value
[7:5]	VOFF setting	VIN UVLO 2.8V to 3.5V per 0.1V to power off PMIC 000 : 2.8V 001 : 2.9V 010 : 3V 011 : 3.1V 100 : 3.2V 101 : 3.3V 110 : 3.4V 111 : 3.5V	R/W	Option
4	Reserved		R/W	0
3	Buck4	Buck4 control (0 : Disable Buck4/1 : Enable Buck4)	R/W	Option
2	Buck3	Buck3 control (0 : Disable Buck3/1 : Enable Buck3)	R/W	Option
1	Buck2	Buck2 control (0 : Disable Buck2/1 : Enable Buck2)	R/W	Option
0	Buck1	Buck1 control (0 : Disable Buck1/1 : Enable Buck1)	R/W	Option

Address	13	LDOs On/Off		
Bit	Name	Description	R/W	Reset Value
7	LDO8	LDO8 control (0 : Disable LDO8 / 1 : Enable LDO8)	R/W	Option
6	LDO7	LDO7 control (0 : Disable LDO7 / 1 : Enable LDO7)	R/W	Option
5	LDO6	LDO6 control (0 : Disable LDO6 / 1 : Enable LDO6)	R/W	Option
4	LDO5	LDO5 control (0 : Disable LDO5 / 1 : Enable LDO5)	R/W	Option
3	LDO4	LDO4 control (0 : Disable LDO4 / 1 : Enable LDO4)	R/W	Option
2	LDO3	LDO3 control (0 : Disable LDO3 / 1 : Enable LDO3)	R/W	Option
1	LDO2	LDO2 control (0 : Disable LDO2 / 1 : Enable LDO2)	R/W	Option
0	LDO1	LDO1 control (0 : Disable LDO1 / 1 : Enable LDO1)	R/W	Option

Address	14	PWRON(Power On Key) time Parameters Setting / $\overline{\text{RESET}}$ delay		
Bit	Name	Description	R/W	Reset Value
[7:6]	START_TIME	Startup time setting 00 : 100 $\mu$ s (pressing time - low level) 01 : 100ms 10 : 1s 11 : 2s	R/W	Option
[5:4]	L_PRESS_TIME	Long-press time setting (after Power-On, 00 : 1s (falling edge to rising edge) 01 : 1.5s 10 : 2s 11 : 2.5s Sending short/long-press IRQ to CPU ex : 1.5s => low time < 1.5s (short IRQ) => low time > 1.5s but < 6s (shutdown time) (long IRQ) => low time > 6s (shutdown time) (shutdown)	R/W	Option
[3:2]	SHDN_PRESS	Key-press forced shutdown time setting 00 : 4s/0ms (pressing time : low level) 01 : 6s/1ms 10 : 8s/1ms 11 : 10s/2ms (allow option 0/1/1/2ms by SHDN_PRESS_SHORT)	R/W	Option
[1:0]	$\overline{\text{RESET\_DLY}}$	$\overline{\text{RESET}}$ signal delay after the last power startup is done 00 : 10ms 01 : 50ms 10 : 100ms 11 : 200ms/5ms (allow option 5ms by RESET_DLY_5ms_EN)	R/W	Option

Address	15	SHDN Control		
Bit	Name	Description	Read/Write	Reset Value
7	SHDN_CTRL	Power Off setting by CPU, after set, 100ms delayed power off 0 : Normal operation 1 : Disable the PMIC output	R/W	0
6	SHDN_TIMING	Disable Buck/LDO only for normal power off (SHDN_CTRL = 1) 0 : disable at the same time 1 : contrary to the startup timing (first_on-last_off)	R/W	Option
[5:4]	SHDN_DLYTIME	Delayed shutdown time after send the (PWRON)key-press-forced-shutdown IRQ (when IRQ is disable, there is no delay) 00 : 100ms 01 : 500ms 10 : 1s 11 : 2s	R/W	Option
3	Reserved		R/W	0
2	RESET_DLY_5ms_EN	0 : 0x14[1:0] = 11, reset delay is 200ms 1 : 0x14[1:0] = 11, reset delay is 5ms	R/W	Option
1	SHDN_PRESS_SHORT	0 : 0x14[3:2], SHDN_PRESS time is 4s/6s/8s/10s 1 : 0x14[3:2], SHDN_PRESS time is 0ms/1ms/1ms/2ms	R/W	Option
0	PWRON_NORMOFF_EN	PWRON off sequence 0 : disable this event. 1 : enable this event	R/W	Option

Address	16	Powered off conditions enable setting		
Bit	Name	Description	Read/Write	Reset Value
7	BCK1LV_ENSHDN	Buck1 output voltage low SHDN 0 : disable this event. 1 : enable this event	R/W	0
6	BCK2LV_ENSHDN	Buck2 output voltage low SHDN 0 : disable this event. 1 : enable this event	R/W	0
5	BCK3LV_ENSHDN	Buck3 output voltage low SHDN 0 : disable this event. 1 : enable this event	R/W	0
4	BCK4LV_ENSHDN	Buck4 output voltage low SHDN 0 : disable this event. 1 : enable this event	R/W	0
3	PWRON_ENSHDN	PWRON key-pressed forced SHDN 0 : disable this event. 1 : enable this event	R/W	1
2	OT_ENSHDN	Over temperature SHDN 0 : disable this event. 1 : enable this event	R/W	1
1	VINLV_ENSHDN	VIN voltage low (VOFF) SHDN 0 : disable this event. 1 : enable this event	R/W	Option
0	VINLV_SEQ_EN	Off sequence after VIN voltage low (VOFF) 0 : disable this event. 1 : enable this event	R/W	Option
Address	17	OFF Event (Only reset by POR)		
Bit	Name	Description	Read/Write	Reset Value
[7:4]	OFF_Event	Powered off because of (Only shows last power-off event) 0000 : VIN voltage low (VOFF) (Set by reg) 0001 : Buck1 output voltage low 0010 : Buck2 output voltage low 0011 : Buck3 output voltage low 0100 : PWRON key-pressed forced shutdown 0101 : Power Off register setting 0110 : Over temperature event 0111 : Reboot restart. 1000 : Buck4 output voltage low 1001 : PWR_HOLD fail. 1010 : No event happen. .... 1111 : No event happen	R	1111
[3:0]	Reserved		R	0000
Address	18 to 27	16 bytes registers Data Cache (Only reset by POR)	R/W	0

IRQ_PMIC (Power Channels)				
Address	28	IRQ Enable1		
Bit	Name	Description	Read/Write	Reset Value
7	OT_IRQ	Internal over-temperature was triggered, IRQ enable	R/W	1
6	Bck1LV_IRQ	Buck1 output voltage equal 66% x V <sub>Target</sub> , IRQ enable	R/W	1
5	Bck2LV_IRQ	Buck2 output voltage equal 66% x V <sub>Target</sub> , IRQ enable	R/W	1
4	Bck3LV_IRQ	Buck3 output voltage equal 66% x V <sub>Target</sub> , IRQ enable	R/W	1
3	Bck4LV_IRQ	Buck4 output voltage equal 66% x V <sub>Target</sub> , IRQ enable	R/W	1
2	PWRONSP_IRQ	PWRON short press, IRQ enable (32μs deglitch time)	R/W	0
1	PWRONLP_IRQ	PWRON long press, IRQ enable (32μs deglitch time)	R/W	0
0	SYSLV_IRQ	VIN voltage is lower than V <sub>OFF</sub> , IRQ enable	R/W	0
Address	29	IRQ Status1		
Bit	Name	Description	Read/Write	Reset Value
7	OT	Internal over-temperature	R	0
6	Bck1LV	Buck1 output voltage equal 66% x V <sub>Target</sub>	R	0
5	Bck2LV	Buck2 output voltage equal 66% x V <sub>Target</sub>	R	0
4	Bck3LV	Buck3 output voltage equal 66% x V <sub>Target</sub>	R	0
3	Bck4LV	Buck4 output voltage equal 66% x V <sub>Target</sub>	R	0
2	PWRONSP	PWRON short press (32μs deglitch time)	R	0
1	PWRONLP	PWRON long press (32μs deglitch time)	R	0
0	VINLV	VIN voltage is lower than V <sub>OFF</sub>	R	0
Address	2A	IRQ Enable2		
Bit	Name	Description	Read/Write	Reset Value
7	KPSHDN_IRQ	Key-press forced shutdown, IRQ enable	R/W	1
6	PWRONR_IRQ	PWRON press rising edge, IRQ enable	R/W	0
5	PWRONF_IRQ	PWRON press falling edge, IRQ enable	R/W	0
[4:0]	Reserved		R	0000
Address	2B	IRQ Status2		
Bit	Name	Description	Read/Write	Reset Value
7	KPSHDN	Key-press forced shutdown	R	0
6	PWRONR	PWRON press rising edge	R	0
5	PWRONF	PWRON press falling edge	R	0
[4:2]	Reserved		R	000
1	OTW125	Internal 125°C pre-warning over-temperature.	R	0
0	OTW100	Internal 100°C pre-warning over-temperature.	R	0

Address	2C	PMU On/Off Sequence1		
Bit	Name	Description (Setting on/off sequence priority) (0000 : off, 0001 : first on, 1100 : last on) (The sequence is planed by first on last off)	Read/Write	Reset Value
[7:4]	Buck2_Seq[3:0]	Setting Buck2 on/off sequence priority	R/W	Option
[3:0]	Buck1_Seq[3:0]	Setting Buck1 on/off sequence priority	R/W	Option
Address	2D	PMU On/Off Sequence2		
Bit	Name	Description (Setting on/off sequence priority) (0000 : off, 0001 : first on, 1100 : last on) (The sequence is planed by first on last off)	Read/Write	Reset Value
[7:4]	Buck4_Seq[3:0]	Setting Buck4 on/off sequence priority	R/W	Option
[3:0]	Buck3_Seq[3:0]	Setting Buck3 on/off sequence priority	R/W	Option
Address	2E	PMU On/Off Sequence3		
Bit	Name	Description (Setting on/off sequence priority) (0000 : off, 0001 : first on, 1100 : last on) (The sequence is planed by first on last off)	Read/Write	Reset Value
[7:4]	LDO2_Seq[3:0]	Setting LDO2 on/off sequence priority	R/W	Option
[3:0]	LDO1_Seq[3:0]	Setting LDO1 on/off sequence priority	R/W	Option
Address	2F	PMU On/Off Sequence4		
Bit	Name	Description (Setting on/off sequence priority) (0000 : off, 0001 : first on, 1100 : last on) (The sequence is planed by first on last off)	Read/Write	Reset Value
[7:4]	LDO4_Seq[3:0]	Setting LDO4 on/off sequence priority	R/W	Option
[3:0]	LDO3_Seq[3:0]	Setting LDO3 on/off sequence priority	R/W	Option
Address	30	PMU On/Off Sequence5		
Bit	Name	Description (Setting on/off sequence priority) (0000 : off, 0001 : first on, 1100 : last on) (The sequence is planed by first on last off)	Read/Write	Reset Value
[7:4]	LDO6_Seq[3:0]	Setting LDO6 on/off sequence priority	R/W	Option
[3:0]	LDO5_Seq[3:0]	Setting LDO5 on/off sequence priority	R/W	Option
Address	31	PMU On Sequence6		
Bit	Name	Description (Setting on/off sequence priority) (0000 : off, 0001 : first on, 1100 : last on) (The sequence is planed by first on last off)	Read/Write	Reset Value
[7:4]	LDO8_Seq[3:0]	Setting LDO8 on/off sequence priority	R/W	Option
[3:0]	LDO7_Seq[3:0]	Setting LDO7 on/off sequence priority	R/W	Option
Address	32	Soft-Start Control		
Bit	Name	Description	Read/Write	Reset Value
[7:6]	Reserved		R	Option

[5:2]	Soft-Start End Control @ MASK_GPIO = 0 (External Enable pin define)	0000 : First turn on channel decide the RESET_DLY time. 0001 : Buck1 decide the RESET_DLY time. .... 0100 : Buck4 decide the RESET_DLY time. 0101 : LDO1 decide the RESET_DLY time. .... 1100 : LDO8 decide the RESET_DLY time. .... 1111 : LDO8 decide the RESET_DLY time.	R/W	Option
[1:0]	Soft-Start Voltage level / time soft-start control.	Voltage Level 00 : When output voltage arrives to 80% V <sub>Target</sub> , next channel will turn on. Soft-start time interval (TSS) : 01 : 1ms 10 : 4ms 11 : 8ms	R/W	Option
Address	33	Buck Syn-Clock Control		
Bit	Name	Description	Read/Write	Reset Value
[7:6]	VCO_VRC	VCO input voltage slop. 00: 25mV/10μs, 01: 25mV/20μs 10: 25mV/40μs, 11: 25mV/80μs Note : The VCO's voltage input range is 0.375V to 1.8V and the output frequency is 500kHz to 2.18MHz.	R/W	Option
[5:0]	VCO_DVS	VCO input voltage DVS control 000000 : 0.375V (500kHz) ..... 111001 : 1.8V (2MHz) ..... 111111 : 1.8V (2MHz)	R/W	Option
Address	34	Buck Syn-Clock Spread Spectrum Control		
Bit	Name	Description	Read/Write	Reset Value
[7:1]	Reserved		R/W	0000000
0	SSOSC	Buck Clock Spread Spectrum Control 0 : Disable spread spectrum function. 1 : Turn on spread spectrum function.	R/W	Option
Address	3A	EEPROM (MTP) Control		
Bit	Name	Description	Read/Write	Reset Value
[7:6]	Reserved		R/W	00
5	MTP Page 2 Read	Read MTP Page 2	R	0
4	MTP Page 1 Read	Read MTP Page 1	R	0
[3:2]	Reserved		R/W	00
1	MTP Page 2 write	Write MTP Page 2, and MTP also needs to be logic high.	W	0
0	MTP Page 1 write	Write MTP Page 1, and MTP also needs to be logic high.	W	0

**Table 3. I<sup>2</sup>C to MTP Mapping Table**  
MTP Page-1

I <sup>2</sup> C Register Address		Bit7	Bit6	Bit5	Bit4	Bit3	Bit2	Bit1	Bit0
0x01	Function	BUCKcontrol1							
	Meaning	Buck1Output[5:0]						Buck1VRC	
	Default	0	0	1	1	0	0	0	0
	Read/Write	R/W	R/W	R/W	R/W	R/W	R/W	R/W	R/W
	Reset Condition	A	A	A	A	A	A	A	A
0x02	Function	BUCKcontrol2							
	Meaning	Buck2Output[5:0]						Buck2VRC	
	Default	0	0	1	1	0	0	0	0
	Read/Write	R/W	R/W	R/W	R/W	R/W	R/W	R/W	R/W
	Reset Condition	A	A	A	A	A	A	A	A
0x03	Function	BUCKcontrol3							
	Meaning	Buck3Output[5:0]						Buck3VRC	
	Default	0	0	1	0	0	0	0	0
	Read/Write	R/W	R/W	R/W	R/W	R/W	R/W	R/W	R/W
	Reset Condition	A	A	A	A	A	A	A	A
0x04	Function	BUCKcontrol4							
	Meaning	Buck4Output[5:0]						Buck4VRC	
	Default	0	1	0	0	0	0	0	0
	Read/Write	R/W	R/W	R/W	R/W	R/W	R/W	R/W	R/W
	Reset Condition	A	A	A	A	A	A	A	A
0x05	Function	VRC Control							
	Meaning	Buck1VR C_EN	Buck2VR C_EN	Buck3VR C_EN	Buck4VR C_EN	Reserved	Reserved	Reserved	Reserved
	Default	0	0	0	0	0	1	0	1
	Read/Write	R/W	R/W	R/W	R/W	R/W	R/W	R/W	R/W
	Reset Condition	A	A	A	A	A	A	A	A
0x06	Function	BUCK Mode							
	Meaning	Buck1 mode	Buck2 mode	Buck3 mode	Buck4 mode	Buck1om s	Buck2om s	Buck3om s	Buck4om s
	Default	0	0	0	0	1	1	1	1
	Read/Write	R/W	R/W	R/W	R/W	R/W	R/W	R/W	R/W
	Reset Condition	A	A	A	A	A	A	A	A

I <sup>2</sup> C Register Address		Bit7	Bit6	Bit5	Bit4	Bit3	Bit2	Bit1	Bit0
0x07	Function	LDOcontrol1							
	Meaning	Reserved	LDO1OUT[6:0]						
	Default	0	0	1	1	1	1	0	0
	Read/Write	R/W	R/W	R/W	R/W	R/W	R/W	R/W	R/W
	Reset Condition	A	A	A	A	A	A	A	A
0x08	Function	LDOcontrol2							
	Meaning	Reserved	LDO2OUT[6:0]						
	Default	0	0	0	0	1	0	0	0
	Read/Write	R/W	R/W	R/W	R/W	R/W	R/W	R/W	R/W
	Reset Condition	A	A	A	A	A	A	A	A
0x09	Function	LDOcontrol3							
	Meaning	Reserved	LDO3OUT[6:0]						
	Default	0	0	1	1	1	1	0	0
	Read/Write	R/W	R/W	R/W	R/W	R/W	R/W	R/W	R/W
	Reset Condition	A	A	A	A	A	A	A	A
0x0A	Function	LDOcontrol4							
	Meaning	Reserved	LDO4OUT[6:0]						
	Default	0	0	0	1	1	0	0	0
	Read/Write	R/W	R/W	R/W	R/W	R/W	R/W	R/W	R/W
	Reset Condition	A	A	A	A	A	A	A	A
0x0B	Function	LDOcontrol5							
	Meaning	Reserved	LDO5OUT[6:0]						
	Default	0	0	0	0	0	1	0	0
	Read/Write	R/W	R/W	R/W	R/W	R/W	R/W	R/W	R/W
	Reset Condition	A	A	A	A	A	A	A	A
0x0C	Function	LDOcontrol6							
	Meaning	Reserved	LDO6OUT[6:0]						
	Default	0	0	0	0	0	1	0	0
	Read/Write	R/W	R/W	R/W	R/W	R/W	R/W	R/W	R/W
	Reset Condition	A	A	A	A	A	A	A	A
0x0D	Function	LDOcontrol7							
	Meaning	Reserved	LDO7OUT[6:0]						
	Default	0	0	1	1	1	1	0	0
	Read/Write	R/W	R/W	R/W	R/W	R/W	R/W	R/W	R/W
	Reset Condition	A	A	A	A	A	A	A	A

I <sup>2</sup> C Register Address		Bit7	Bit6	Bit5	Bit4	Bit3	Bit2	Bit1	Bit0
0x0E	Function	LDOcontrol8							
	Meaning	Reserved	Reserved						
	Default	0	0	1	1	1	1	0	0
	Read/Write	R/W	R/W	R/W	R/W	R/W	R/W	R/W	R/W
	Reset Condition	A	A	A	A	A	A	A	A
0x10	Function	REBOOT/PWRHOLD delay time control							
	Meaning	Delayed2[1:0]		Delayed1[1:0]		THOLD		Reserved	DisTHOLD
	Default	1	0	1	0	0	0	0	1
	Read/Write	R/W	R/W	R/W	R/W	R/W	R/W	R/W	R/W
	Reset Condition	A	A	A	A	A	A	A	A
0x12	Function	VIN UVLO (update default value after power on)							
	Meaning	VOFF setting			Reserved	Reserved	Reserved	Reserved	Reserved
	Default	1	1	1	1	1	1	1	1
	Read/Write	R/W	R/W	R/W	R/W	R/W	R/W	R/W	R/W
	Reset Condition	A	A	A	A	B	B	B	B
0x14	Function	PWRON time Parameters Setting / RESET delay							
	Meaning	START_TIME		L_PRESS_TIME		SHDN_PRESS		RESET_DLY	
	Default	0	0	0	0	0	0	1	0
	Read/Write	R/W	R/W	R/W	R/W	R/W	R/W	R/W	R/W
	Reset Condition	A	A	A	A	A	A	A	A
0x15	Function	SHDN Control							
	Meaning	Reserved	SHDN_TIMING	SHDN_DLYTIME		Reserved	RESET_DLY_5ms_EN	SHDN_PRESS_SHORT	PWRON_NORMOFF_EN
	Default	0	1	1	0	0	0	0	0
	Read/Write	R/W	R/W	R/W	R/W	R/W	R/W	R/W	R/W
	Reset Condition	B	A	A	A	A	A	A	A
0x16	Function	Powered Off conditions enable setting							
	Meaning	Reserved	Reserved	Reserved	Reserved	Reserved	Reserved	VINLV_ENSHDN	VINLV_SEQ_EN
	Default	0	0	0	0	0	0	0	1
	Read/Write	R/W	R/W	R/W	R/W	R/W	R/W	R/W	R/W
	Reset Condition	A	A	A	A	A	A	A	A
0x2C	Function	PMU On/Off Sequence1							
	Meaning	Buck2_Seq[3:0]				Buck1_Seq[3:0]			
	Default	0	0	1	0	0	0	0	1
	Read/Write	R/W	R/W	R/W	R/W	R/W	R/W	R/W	R/W
	Reset Condition	A	A	A	A	A	A	A	A

MTP Page-2

I <sup>2</sup> C Register Address		Bit7	Bit6	Bit5	Bit4	Bit3	Bit2	Bit1	Bit0
0x2D	Function	PMU On/Off Sequence2							
	Meaning	Buck4_Seq[3:0]				Buck3_Seq[3:0]			
	Default	0	0	1	1	0	0	1	0
	Read/Write	R/W	R/W	R/W	R/W	R/W	R/W	R/W	R/W
	Reset Condition	A	A	A	A	A	A	A	A
0x2E	Function	PMU On/Off Sequence3							
	Meaning	LDO2_Seq[3:0]				LDO1_Seq[3:0]			
	Default	0	0	1	1	0	0	0	0
	Read/Write	R/W	R/W	R/W	R/W	R/W	R/W	R/W	R/W
	Reset Condition	A	A	A	A	A	A	A	A
0x2F	Function	PMU On/Off Sequence4							
	Meaning	LDO4_Seq[3:0]				LDO3_Seq[3:0]			
	Default	0	0	0	0	0	0	0	0
	Read/Write	R/W	R/W	R/W	R/W	R/W	R/W	R/W	R/W
	Reset Condition	A	A	A	A	A	A	A	A
0x30	Function	PMU On/Off Sequence5							
	Meaning	LDO6_Seq[3:0]				LDO5_Seq[3:0]			
	Default	0	0	0	0	0	0	0	0
	Read/Write	R/W	R/W	R/W	R/W	R/W	R/W	R/W	R/W
	Reset Condition	A	A	A	A	A	A	A	A
0x31	Function	PMU On/Off Sequence6							
	Meaning	LDO8_Seq[3:0]				LDO7_Seq[3:0]			
	Default	0	0	0	0	0	0	0	0
	Read/Write	R/W	R/W	R/W	R/W	R/W	R/W	R/W	R/W
	Reset Condition	A	A	A	A	A	A	A	A
0x32	Function	Soft-Start Control							
	Meaning	Reversed	Reversed	Soft-Start End Select @ MASK_GPIO = 1			Soft-Start Control		
	Default	0	0	0	1	1	0	0	0
	Read/Write	R/W	R/W	R/W	R/W	R/W	R/W	R/W	R/W
	Reset Condition	A	A	A	A	A	A	A	A
0x33	Function	Buck Syn-Clock Control							
	Meaning	VCO_VRC			VCO_DVS				
	Default	0	0	1	1	1	0	0	1
	Read/Write	R/W	R/W	R/W	R/W	R/W	R/W	R/W	R/W
	Reset Condition	A	A	A	A	A	A	A	A

I <sup>2</sup> C Register Address		Bit7	Bit6	Bit5	Bit4	Bit3	Bit2	Bit1	Bit0
0x34	Function	Buck Syn-Clock Spread Spectrum Control							
	Meaning	Reversed	Reversed	Reversed	Reversed	Reversed	Reversed	Reversed	SSOSC
	Default	0	0	0	0	0	0	0	1
	Read/Write	R/W	R/W	R/W	R/W	R/W	R/W	R/W	R/W
	Reset Condition	A	A	A	A	A	A	A	A

**Reset Condition**

A	Reset by MTP (Register 0x12 VOFF Setting).
B	Reset when VIN < 1.7V.

Outline Dimension

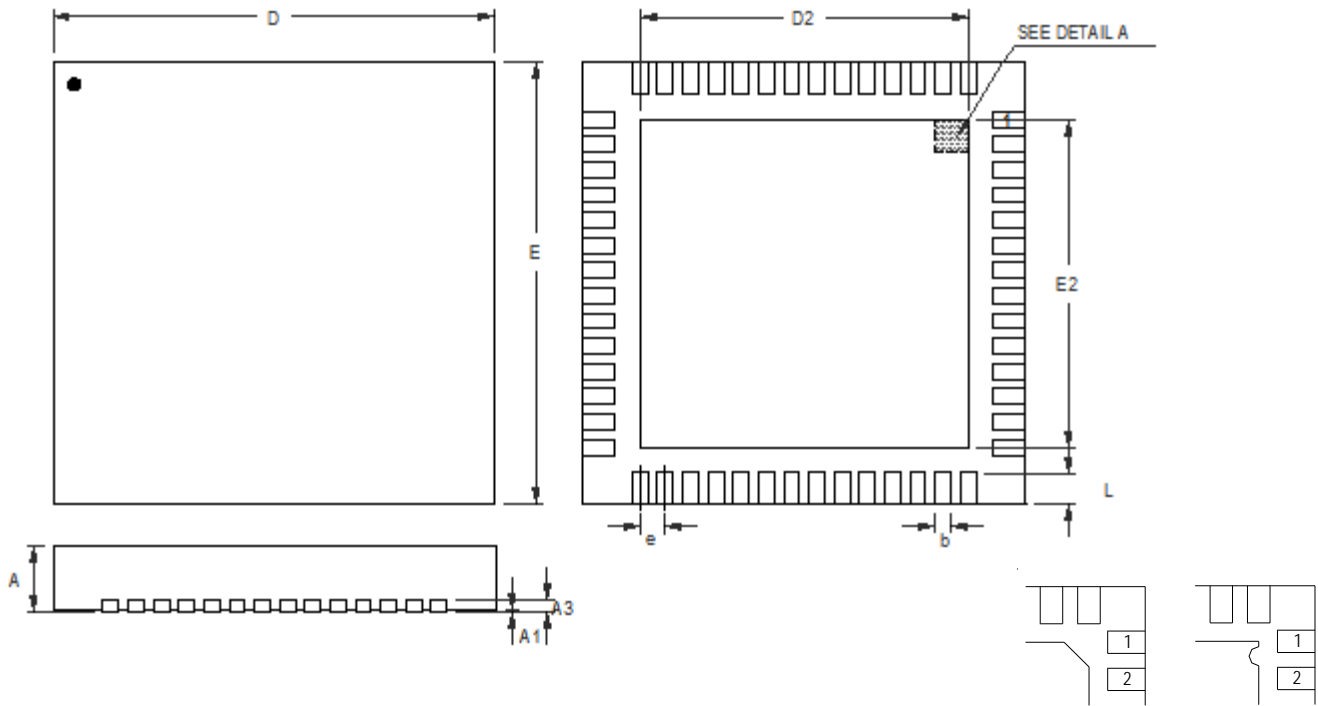

**DETAIL A**

Pin #1 ID and Tie Bar Mark Options

Note : The configuration of the Pin #1 identifier is optional, but must be located within the zone indicated.

Symbol	Dimensions In Millimeters		Dimensions In Inches	
	Min	Max	Min	Max
A	0.700	0.800	0.028	0.031
A1	0.000	0.050	0.000	0.002
A3	0.175	0.250	0.007	0.010
b	0.150	0.250	0.006	0.010
D	6.900	7.100	0.272	0.280
D2	5.150	5.250	0.203	0.207
E	6.900	7.100	0.272	0.280
E2	5.150	5.250	0.203	0.207
e	0.400		0.016	
L	0.350	0.450	0.014	0.018

W-Type 56L QFN 7x7 Package

**Richtek Technology Corporation**

14F, No. 8, Tai Yuen 1<sup>st</sup> Street, Chupei City

Hsinchu, Taiwan, R.O.C.

Tel: (8863)5526789

Richtek products are sold by description only. Richtek reserves the right to change the circuitry and/or specifications without notice at any time. Customers should obtain the latest relevant information and data sheets before placing orders and should verify that such information is current and complete. Richtek cannot assume responsibility for use of any circuitry other than circuitry entirely embodied in a Richtek product. Information furnished by Richtek is believed to be accurate and reliable. However, no responsibility is assumed by Richtek or its subsidiaries for its use; nor for any infringements of patents or other rights of third parties which may result from its use. No license is granted by implication or otherwise under any patent or patent rights of Richtek or its subsidiaries.



## Looking for pricing, stock, or lifecycle information?

Click below to explore more details on WIN SOURCE:

 [View RT5028AGQW on WIN SOURCE](#)

 [Richtek USA Inc. Information](#)

## Optimize Your Supply Chain with WIN SOURCE Solutions

-  Global Sourcing Solution
-  Obsolete Management
-  Cost Control Management
-  Shortage Management
-  Alternative Solution
-  Excess Inventory Management