

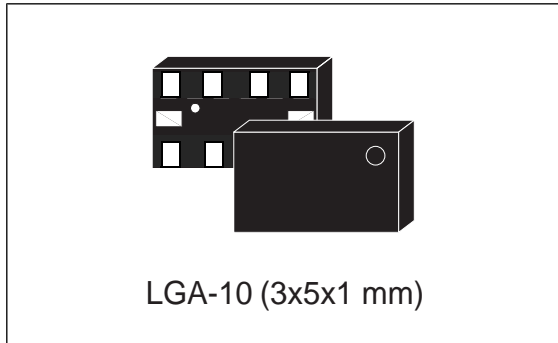

THE DATASHEET OF LY330ALHTR



MEMS motion sensor: high performance ± 300 dps analog yaw-rate gyroscope



Features

- 2.7 V to 3.6 V single-supply operation
- Wide operating temperature range (-40 °C to +85 °C)
- High stability over temperature
- Analog absolute angular-rate outputs
- Integrated low-pass filters
- Low power consumption
- Sleep mode
- Embedded power-down
- Embedded self-test
- High shock and vibration survivability
- ECOPACK[®] RoHS and “Green” compliant

Applications

- Pointing devices, remote and game controllers
- Motion control with user interface
- GPS navigation systems
- Industrial and robotics

Description

The LY330ALH is a high performance low-power single-axis micro-machined gyroscope capable of measuring angular rate along the yaw axis.

It provides excellent temperature stability and high resolution over extended operating temperature range (-40 °C to +85 °C).

The LY330ALH has a full scale of ± 300 dps and is capable of detecting rates with a -3 dB bandwidth up to 140 Hz.

The device includes a sensing element composed of a single driving mass, kept in continuous oscillation and capable of reacting, based on the Coriolis principle, when an angular rate is applied.

A CMOS IC provides the measured angular rate to the external world through an analog output voltage, allowing high levels of integration and production trimming to better match sensing element characteristics.

ST's family of gyroscopes leverages on the mature and robust manufacturing process already used for the production of micro-machined accelerometers.

ST is already in the field with several hundred million sensors which have received excellent acceptance from the market in terms of quality, reliability and performance.

The LY330ALH is available in a plastic land grid array (LGA) package, which ST successfully pioneered for accelerometers. Today ST has the widest manufacturing capability and strongest expertise in the world for production of sensors in plastic LGA packages.

Table 1: Device summary

Order code	Temperature range (°C)	Package	Packing
LY330ALH	-40 to +85	LGA-10 (3x5x1)	Tray
LY330ALHTR	-40 to +85	LGA-10 (3x5x1)	Tape and reel

Contents

- 1 Block diagram5**
- 2 Pin description6**
- 3 Mechanical and electrical characteristics7**
 - 3.1 Mechanical characteristics7
 - 3.2 Electrical characteristics8
 - 3.3 Absolute maximum ratings8
- 4 Terminology10**
 - 4.1 Sensitivity10
 - 4.2 Zero-rate level10
 - 4.3 Self-test10
 - 4.4 Sleep mode, self-test and power-down10
- 5 Application hints11**
 - 5.1 Output response vs. rotation12
 - 5.2 Soldering information12
- 6 Package information13**
 - 6.1 LGA-10 package mechanical data13
- 7 Revision history15**

List of tables

Table 1. Device summary	1
Table 2. Pin description	6
Table 3. Mechanical characteristics @ Vdd = 3 V, T = 25 °C unless otherwise noted	7
Table 4. Electrical characteristics @ Vdd =3 V, T=25 °C unless otherwise noted	8
Table 5. Absolute maximum ratings	8
Table 6. Sleep mode, self-test and power-down mode configuration	10
Table 7. LGA-10 (3x5x1 mm) package dimensions	13
Table 8. Document revision history	15

List of figures

Figure 1. Block diagram11
Figure 2. Pin connection6
Figure 3. Electrical connections and external component values11
Figure 4. Steady state position12
Figure 5. Output response vs. rotation12
Figure 6. LGA-10 (3x5x1 mm) mechanical data13

1 Block diagram

Figure 1: Block diagram

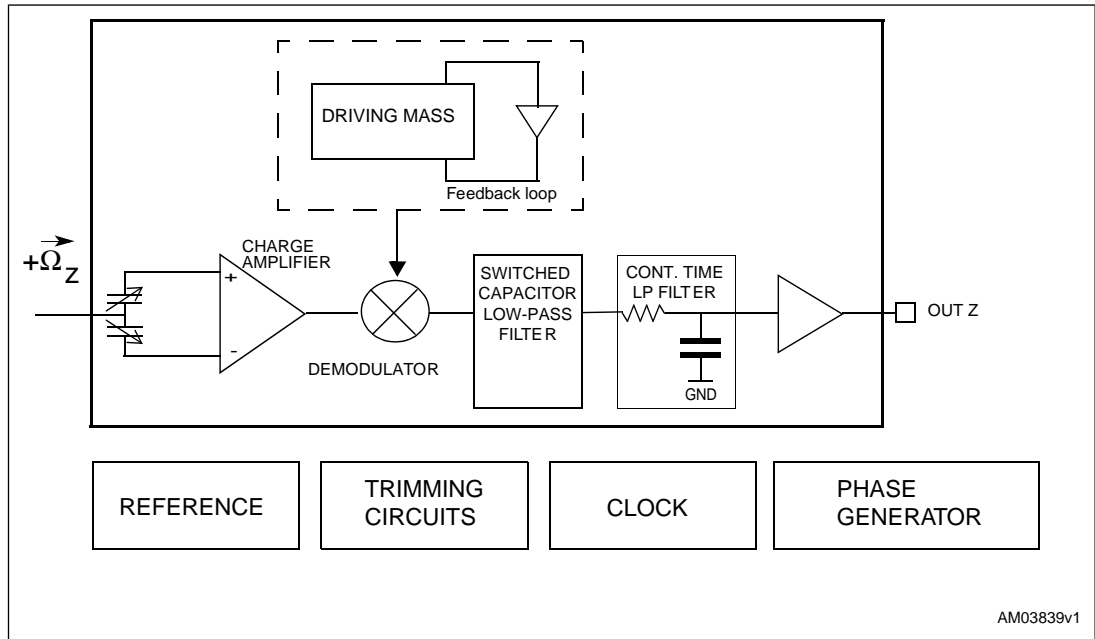

2 Pin description

Figure 2: Pin connection

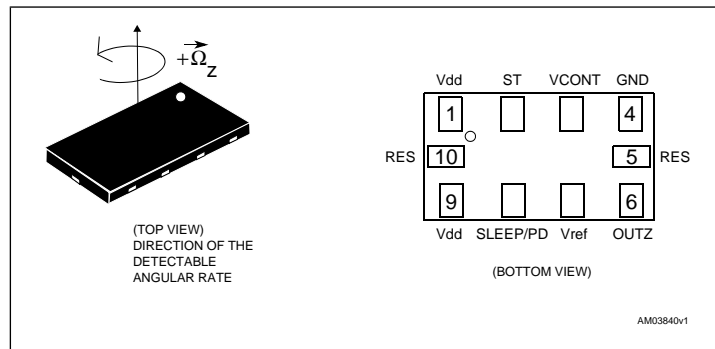

Table 2: Pin description

Pin #	Pin name	Analog function
1	Vdd	Power supply
2	ST	Self-test (see "Sleep mode, self test and power-down mode configuration" table)
3	VCONT	PLL filter connection
4	GND	0 V supply voltage
5	Res	Leave unconnected or connect to Vdd
6	OUTZ	Z axis output voltage
7	Vref	Reference voltage
8	SLEEP/PD	Sleep mode / power-down mode (see "Sleep mode, self test and power-down mode configuration" table)
9	Vdd	Power supply
10	Res	Leave unconnected or connect to Vdd

3 Mechanical and electrical characteristics

3.1 Mechanical characteristics

Table 3: Mechanical characteristics @ Vdd = 3 V, T = 25 °C unless otherwise noted

Symbol	Parameter	Test condition	Min.	Typ. ⁽¹⁾	Max.	Unit
FS	Measurement range			±300		dps
So	Sensitivity ⁽²⁾			3.752		mV/dps
SoDr	Sensitivity change vs. temperature	Delta from 25°C		0.01		%/°C
Voff	Zero-rate level ⁽³⁾			1.5		V
OffDr	Zero-rate level change vs. temperature	Delta from 25°C		0.02		dps/°C
NL	Non linearity	Best fit straight line		±1		% FS
BW	Bandwidth ⁽³⁾			140		Hz
Vst	Self-test output change			400 ⁽⁴⁾		mV
Rn	Rate noise density			0.014		dps / √Hz
Top	Operating temperature range		-40		85	°C

(1) Typical specifications are not guaranteed.

(2) Sensitivity and zero-rate level are not ratiometric to supply voltage.

(3) The product is capable of measuring angular rates extending from DC to the selected BW.

(4) Self test typical absolute value.

 **Note:**

The product is factory calibrated at 3 V. The operational power supply range is specified in the Electrical characteristics table.

3.2 Electrical characteristics

Table 4: Electrical characteristics @ Vdd =3 V, T=25 °C unless otherwise noted

Symbol	Parameter	Test condition	Min.	Typ. ⁽¹⁾	Max.	Unit
Vdd	Supply voltage		2.7	3	3.6	V
Idd	Supply current			4.2		mA
IddSI	Supply current sleep mode			2.2		mA
IddPdn	Supply current in power-down mode			5		μA
Vst	Self-test input	Logic 0 level	0		0.2*Vdd	V
		Logic 1 level	0.8*Vdd		Vdd	
Vpd	Power-down input	Logic 0 level	0		0.2*Vdd	V
		Logic 1 level	0.8*Vdd		Vdd	
Top	Operating temperature range		-40		+85	°C

⁽¹⁾Typical specifications are not guaranteed

 **Note:**

The product is factory calibrated at 3 V.

3.3 Absolute maximum ratings

Stresses above those listed as "Absolute maximum ratings" may cause permanent damage to the device. This is a stress rating only and functional operation of the device under these conditions is not implied. Exposure to maximum rating conditions for extended periods may affect device reliability.

Table 5: Absolute maximum ratings

Symbol	Ratings	Maximum value	Unit
Vdd	Supply voltage	-0.3 to 6	V
Vin	Input voltage on any control pin (Sleep/PD, ST)	-0.3 to Vdd +0.3	V
A	Acceleration	3000 for 0.5 ms	g
		10000 for 0.1 ms	g

Symbol	Ratings	Maximum value	Unit
T _{STG}	Storage temperature range	-40 to +125	°C
ESD	Electrostatic discharge protection	2 (HBM)	kV



This is a mechanical shock sensitive device, improper handling can cause permanent damage to the part.



This is an ESD sensitive device, improper handling can cause permanent damage to the part.

4 Terminology

4.1 Sensitivity

An angular rate gyroscope is a device that produces a positive-going output voltage for counterclockwise rotation around the sensitive axis considered. Sensitivity describes the gain of the sensor and can be determined by applying a defined angular velocity to it. This value changes very little over temperature and time.

4.2 Zero-rate level

Zero-rate level describes the actual output signal if there is no angular rate present. The zero-rate level of precise MEMS sensors is, to some extent, a result of stress to the sensor and therefore zero-rate level can slightly change after mounting the sensor onto a printed circuit board or after exposing it to extensive mechanical stress. This value changes very little over temperature and time.

4.3 Self-test

Self-test allows testing of the mechanical and electrical part of the sensor, allowing the seismic mass to be moved by means of an electrostatic test-force. The self-test function is off when the ST pin is connected to GND. When the ST pin is tied to Vdd, an actuation force is applied to the sensor, emulating a definite Coriolis force. In this case the sensor output exhibits a voltage change in its DC level which is also dependent on the supply voltage. When ST is active, the device output level is given by the algebraic sum of the signals produced by the velocity acting on the sensor and by the electrostatic test-force. If the output signals change within the amplitude specified in the Mechanical characteristics table, then the mechanical element is working properly and the parameters of the interface chip are within the defined specifications.

4.4 Sleep mode, self-test and power-down

The device enables advanced power-saving features thanks to the availability of three different operating modes. In addition to standard normal mode and Power-down mode, when the device is set in a sleep mode configuration, the reading chain is completely turned off, resulting in low power consumption. In this condition the device turn-on time is significantly reduced, allowing simple external power cycling. In accordance with the table below, the user can select the desired operating mode using two dedicated pins (ST and SLEEP/PD).

Table 6: Sleep mode, self-test and power-down mode configuration

Operating mode	ST pin	SLEEP/PD pin
Normal mode	0	0
Sleep mode	0	1
Self-test	1	0
Power-down	1	1

5 Application hints

Figure 3: Electrical connections and external component values

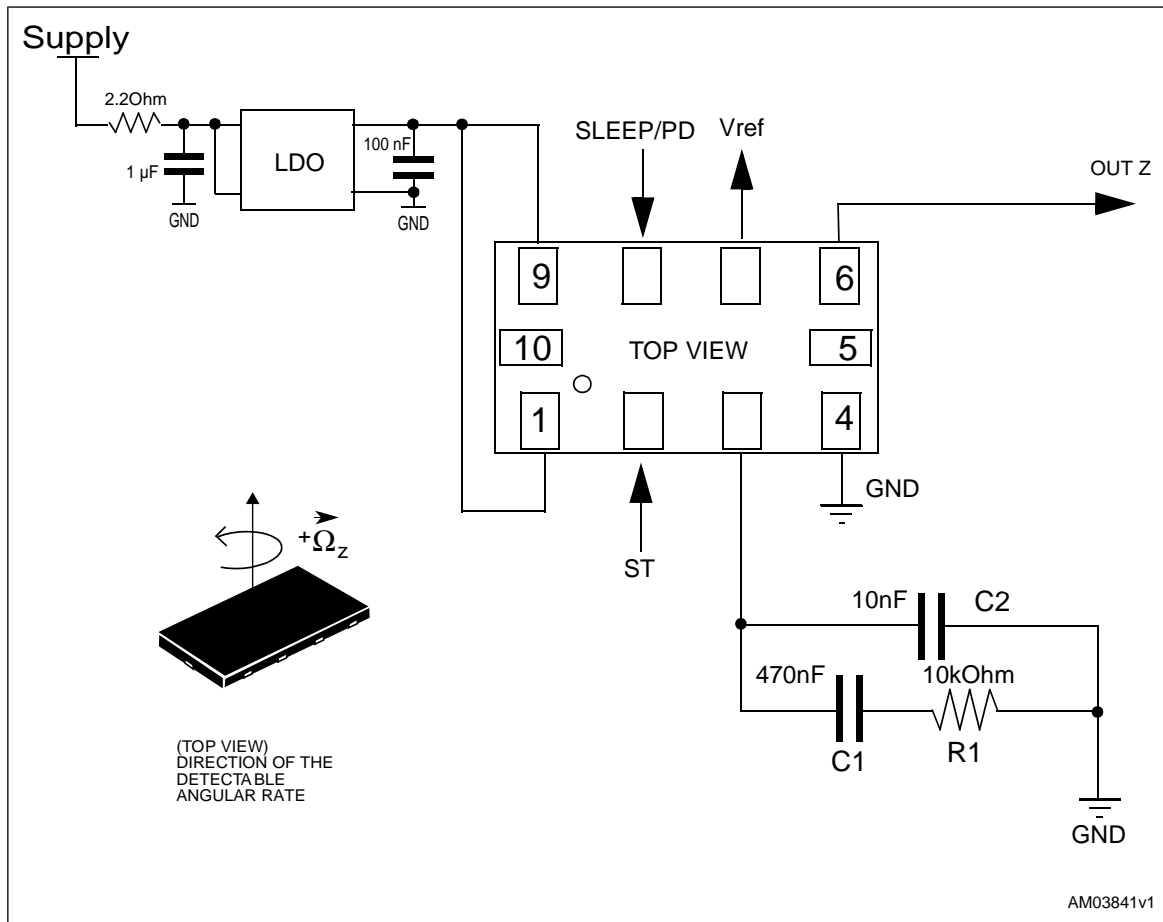

Power supply decoupling capacitors should be placed in combination with an LDO regulator (common design practice).

The device IC includes a PLL (phase-locked loop) circuit to synchronize driving and sensing interfaces. Capacitors and resistor must be added at **VCONT** pin 3 (see figure above) to implement a low-pass filter.

5.1 Output response vs. rotation

Figure 4: Steady state position

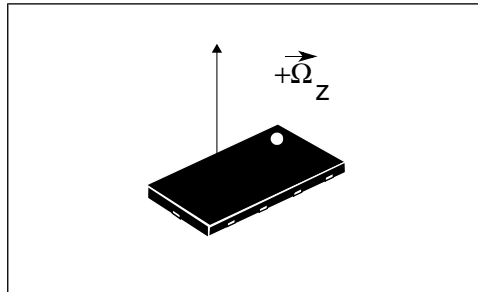

 **Note:**

$$\text{OUTZ} = 1.5 \text{ V}$$

Figure 5: Output response vs. rotation

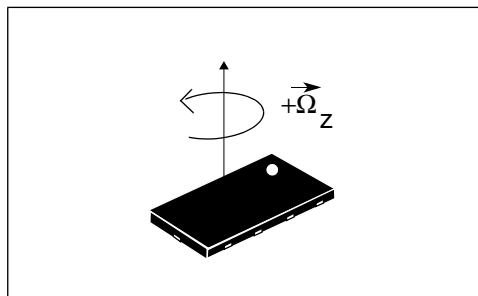

 **Note:**

Positive rotations as indicated by arrows increase output value over zero-rate level:

$$\text{OUTZ} = 1.5 \text{ V} + \text{SoA} \cdot 300 = 2.62 \text{ V}$$

5.2 Soldering information

The LGA package is compliant with the ECOPACK[®], RoHS and "Green" standard. It is qualified for soldering heat resistance according to JEDEC J-STD-020.

Leave "pin 1 indicator" unconnected during soldering.

Land pattern and soldering recommendations are available at www.st.com.

6 Package information

In order to meet environmental requirements, ST offers these devices in different grades of ECOPACK[®] packages, depending on their level of environmental compliance. ECOPACK[®] specifications, grade definitions and product status are available at: www.st.com. ECOPACK[®] is an ST trademark.

6.1 LGA-10 package mechanical data

Figure 6: LGA-10 (3x5x1 mm) mechanical data

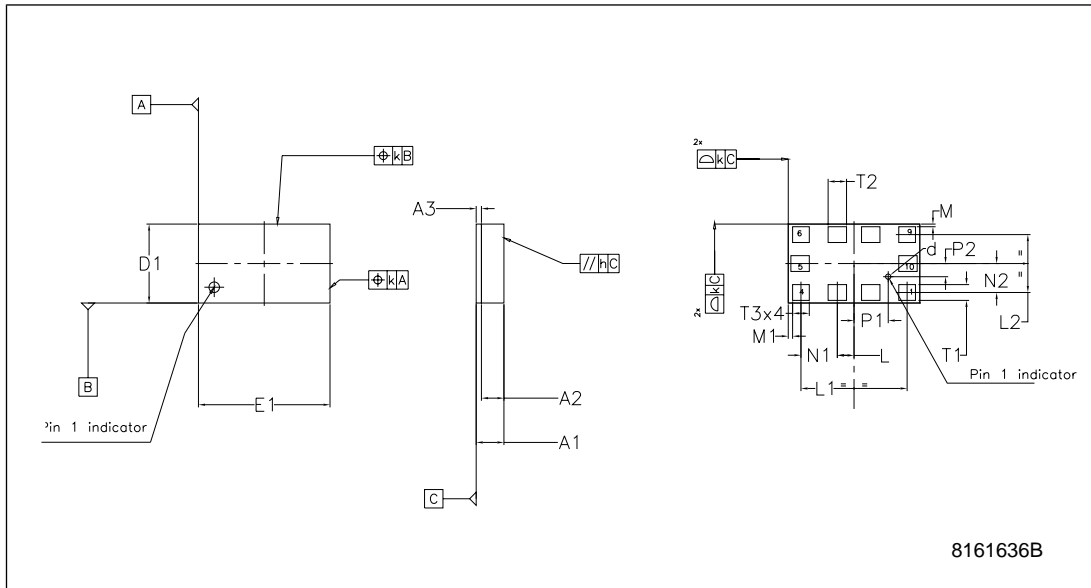

Table 7: LGA-10 (3x5x1 mm) package dimensions

Ref.	Dimensions		
	mm		
	Min.	Typ.	Max.
A1			1.100
A2		0.855	
A3		0.200	
D1	2.850	3.000	3.150
E1	4.850	5.000	5.150
L		0.635	
L1		4.035	
L2		2.200	
N1		1.382	

Ref.	Dimensions		
	mm		
	Min.	Typ.	Max.
N2		1.100	
M		0.100	
P1		1.300	
P2		0.500	
T1		0.600	
T2		0.700	
T3		0.635	
d		0.200	
k		0.050	
h		0.100	

7 Revision history

Table 8: Document revision history

Date	Revision	Changes
29-Oct-2009	1	Initial release.
19-Feb-2010	2	Minor text changes and updated package information.

Please Read Carefully

Information in this document is provided solely in connection with ST products. STMicroelectronics NV and its subsidiaries ("ST") reserve the right to make changes, corrections, modifications or improvements, to this document, and the products and services described herein at anytime, without notice.

All ST products are sold pursuant to ST's terms and conditions of sale.

Purchasers are solely responsible for the choice, selection and use of the ST products and services described herein, and ST assumes no liability whatsoever relating to the choice, selection or use of the ST products and services described herein.

No license, express or implied, by estoppel or otherwise, to any intellectual property rights is granted under this document. If any part of this document refers to any third party products or services it shall not be deemed a license grant by ST for the use of such third party products or services, or any intellectual property contained therein or considered as a warranty covering the use in any manner whatsoever of such third party products or services or any intellectual property contained therein.

UNLESS OTHERWISE SET FORTH IN ST'S TERMS AND CONDITIONS OF SALE ST DISCLAIMS ANY EXPRESS OR IMPLIED WARRANTY WITH RESPECT TO THE USE AND/OR SALE OF ST PRODUCTS INCLUDING WITHOUT LIMITATION IMPLIED WARRANTIES OF MERCHANTABILITY, FITNESS FOR A PARTICULAR PURPOSE (AND THEIR EQUIVALENTS UNDER THE LAWS OF ANY JURISDICTION), OR INFRINGEMENT OF ANY PATENT, COPYRIGHT OR OTHER INTELLECTUAL PROPERTY RIGHT.

UNLESS EXPRESSLY APPROVED IN WRITING BY AN AUTHORIZED ST REPRESENTATIVE, ST PRODUCTS ARE NOT RECOMMENDED, AUTHORIZED OR WARRANTED FOR USE IN MILITARY, AIR CRAFT, SPACE, LIFE SAVING, OR LIFE SUSTAINING APPLICATIONS, NOR IN PRODUCTS OR SYSTEMS WHERE FAILURE OR MALFUNCTION MAY RESULT IN PERSONAL INJURY, DEATH, OR SEVERE PROPERTY OR ENVIRONMENTAL DAMAGE. ST PRODUCTS WHICH ARE NOT SPECIFIED AS "AUTOMOTIVEGRADE" MAY ONLY BE USED IN AUTOMOTIVE APPLICATIONS AT USER'S OWN RISK.

Resale of ST products with provisions different from the statements and/or technical features set forth in this document shall immediately void any warranty granted by ST for the ST product or service described herein and shall not create or extend in any manner whatsoever, any liability of ST.

ST and the ST logo are trademarks or registered trademarks of ST in various countries.

Information in this document supersedes and replaces all information previously supplied.

The ST logo is a registered trademark of STMicroelectronics. All other names are the property of their respective owners.

© 2010 STMicroelectronics - All rights reserved



STMicroelectronics group of companies

Australia - Belgium - Brazil - Canada - China - Czech Republic - Finland - France - Germany - Hong Kong - India - Israel - Italy - Japan - Malaysia - Malta - Morocco - Philippines - Singapore - Spain - Sweden - Switzerland - United Kingdom - United States of America

www.st.com

Looking for pricing, stock, or lifecycle information?

Click below to explore more details on WIN SOURCE:

-  [View LY330ALHTR](#) on WIN SOURCE
-  [STMicroelectronics](#) Information

Optimize Your Supply Chain with WIN SOURCE Solutions

-  Global Sourcing Solution
-  Obsolete Management
-  Cost Control Management
-  Shortage Management
-  Alternative Solution
-  Excess Inventory Management