



**THE DATASHEET OF  
MAX96706GTJ/V+T**



## MAX96706

## 14-Bit GMSL Deserializer with Coax or STP Cable Input

### General Description

The MAX96706 is a compact deserializer especially suited for automotive camera applications. Features include adaptive equalization and an output crosspoint switch. An embedded control channel operates at 9.6kbps to 1Mbps in UART, I<sup>2</sup>C, and mixed UART/I<sup>2</sup>C modes, allowing programming of serializer, deserializer (SerDes), and camera registers, independent of video timing.

The deserializer can track data from a spread-spectrum serial input. The serial input meets ISO 10605 and IEC 61000-4-2 ESD standards. The core supply range is 1.7V to 1.9V and the I/O supply range is 1.7V to 3.6V. The device is available in a 32-pin (5mm x 5mm) TQFN and SWTQFN package with 0.5mm lead pitch and operates over -40°C to +115°C temperature range.

### Applications

- Automotive Camera Applications

### Simplified Block Diagram

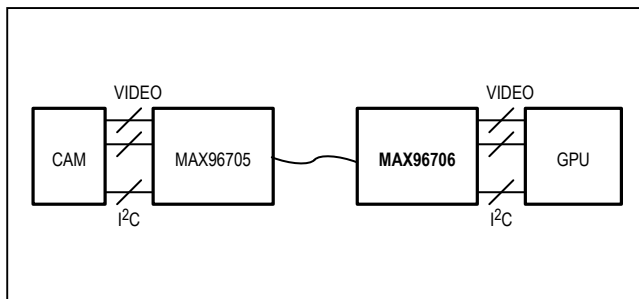

[Ordering Information](#) appears at end of data sheet.

### Benefits and Features

- Ideal for Safety Camera Applications
  - Works with Low-Cost 50Ω Coax (100Ω STP) Cable
  - Error Detection of Video/Control Data
  - High-Immunity Mode for Robust Control-Channel EMC Tolerance
  - Retransmission of Control Data Upon Error
  - Best-in-Class Supply Current: 190mA (max)
  - Adaptive Equalization for 15m Cable at Full Speed
  - 32-Pin (5mm x 5mm) TQFN/SWTQFN Package
  - Horizontal- and Vertical-Sync Encoding and Tracking
- High-Speed Deserialization for Megapixel Cameras
  - Up to 1.74Gbps Serial-Bit Rate
  - 6.25MHz to 87MHz x 12-Bit + H/V Data
  - 36.66MHz to 116MHz x 12-Bit + H/V Data (through Internal Encoding)
- Multiple Modes for System Flexibility
  - 9.6kbps to 1Mbps Control Channel in UART, I<sup>2</sup>C (with Clock Stretch), or UART-to-I<sup>2</sup>C Modes
  - 2:1 Input Mux for Camera Selection
  - 15 Hardware-Selectable I<sup>2</sup>C-Device Addresses
  - Pairs with Any Maxim GMSL Serializer
  - Crosspoint Switch Maps Data to any Output
- Reduces EMI and Shielding Requirements
  - Spread-Spectrum Serial-Input Tracking and Transfer to the Parallel Output
  - 1.7V to 1.9V Core and 1.7V to 3.6V I/O Supply
- Peripheral Features for System Verification
  - Built-In PRBS Receiver for BER Testing
  - Eye-Width Monitor Allows In-System Test of High-Speed Serial Link
  - Dedicated “Up/Down” GPI for Camera Frame Sync Trigger and Other Uses
- Meets AEC-Q100 Automotive Specification
  - 40°C to +115°C Operating Temperature Range
  - ±8kV Contact and ±15kV Air IEC 61000-4-2 and ISO 10605 ESD Protection

General Description . . . . . 1

Applications . . . . . 1

Benefits and Features . . . . . 1

Simplified Block Diagram . . . . . 1

Absolute Maximum Ratings . . . . . 6

Package Thermal Characteristics . . . . . 6

    32-Pin TQFN-EP . . . . . 6

DC Electrical Characteristics . . . . . 7

AC Electrical Characteristics . . . . . 12

Typical Operating Characteristics . . . . . 15

Pin Configuration . . . . . 16

Pin Description . . . . . 17

Functional Diagrams . . . . . 20

Detailed Description . . . . . 26

Serial Link Signaling and Data Format . . . . . 26

    Operating Modes . . . . . 26

    Video/Configuration Link . . . . . 26

    Single and Double Modes of Operation . . . . . 26

    HS/VS Encoding . . . . . 26

    Error Detection . . . . . 26

    Bus Widths . . . . . 27

Control Channel and Register Programming . . . . . 30

    Forward Control Channel . . . . . 30

    Reverse Control Channel . . . . . 30

    UART Interface . . . . . 30

    I<sup>2</sup>C Interface . . . . . 30

    Remote-End Operation . . . . . 30

    Clock-Stretch Timing . . . . . 30

    Packet-Based I<sup>2</sup>C . . . . . 30

    Packet Protocol Summary . . . . . 31

    Control-Channel Error Detection and  
    Packet Retransmission . . . . . 31

GPO/GPI Control . . . . . 31

Adaptive Line Equalizer . . . . . 31

Eye-Width Monitor . . . . . 31

Spread-Spectrum Tracking . . . . . 31

Cable-Type Configuration and Input MUX . . . . . 31

Crosspoint Switch . . . . . 32

Shutdown/Sleep Modes . . . . .	32
Configuration Link . . . . .	32
Serialization Disable . . . . .	32
Sleep Mode . . . . .	32
Power-Down Mode. . . . .	32
Link-Startup Procedure. . . . .	32
Register Map . . . . .	34
Applications Information. . . . .	62
Parallel Interface . . . . .	62
Bus Data Width . . . . .	62
Bus Data Rates . . . . .	62
Crossbar Switch . . . . .	62
Crossbar Switch Programming . . . . .	62
Recommended Crossbar Switch Programming Procedure. . . . .	62
Control-Channel Interfaces. . . . .	65
I <sup>2</sup> C . . . . .	65
I <sup>2</sup> C Bit Rate . . . . .	65
Software Programming of the Device Addresses . . . . .	65
I <sup>2</sup> C Address Translation. . . . .	65
Configuration Blocking . . . . .	65
Cascaded/Parallel Devices . . . . .	65
Dual $\mu$ C Control . . . . .	65
Packet-Based Control-Channel I <sup>2</sup> C. . . . .	65
UART . . . . .	66
Base Mode . . . . .	66
UART Timing . . . . .	66
UART-to-I <sup>2</sup> C Conversion . . . . .	67
UART Bypass Mode . . . . .	68
Device Address . . . . .	68
Cable Equalizer. . . . .	68
ERRB Output . . . . .	68
Auto-Error Reset . . . . .	68
Board Layout. . . . .	68
Power-Supply Circuits and Bypassing. . . . .	68
High-Frequency Signals. . . . .	68
ESD Protection . . . . .	69
Compatibility with Other GMSL Devices . . . . .	69
Device Configuration and Component Selection . . . . .	70

Internal Input Pulldowns . . . . .	70
Multifunction Inputs . . . . .	70
I <sup>2</sup> C/UART Pullup Resistors . . . . .	70
AC-Coupling Capacitors . . . . .	70
Cables and Connectors . . . . .	70
PRBS . . . . .	71
GPI/GPO . . . . .	71
Fast Detection of Loss-of-Lock . . . . .	71
Providing a Frame Sync (Camera Applications) . . . . .	71
Entering/Exiting Sleep Mode . . . . .	71
Legacy Control Channel . . . . .	71
Typical Application Circuit . . . . .	71
Ordering Information . . . . .	72
Revision History . . . . .	73
Figure 1. Reverse Control-Channel Output Parameters . . . . .	21
Figure 2. Test Circuit for Differential Input Measurement . . . . .	22
Figure 4. Line Fault . . . . .	22
Figure 3. Test Circuit for Single-Ended Input Measurement . . . . .	22
Figure 5. Worst-Case Pattern Output . . . . .	23
Figure 6. I <sup>2</sup> C Timing Parameters . . . . .	23
Figure 7. Output Rise-and-Fall Times . . . . .	23
Figure 8. Deserializer Delay . . . . .	24
Figure 9. GPI-to-GPO Delay . . . . .	24
Figure 10. Lock Time . . . . .	24
Figure 11. Power-Up Delay . . . . .	24
Figure 12. Active Output to High-Impedance Time, High Impedance to Active-Output Time Test Circuit . . . . .	25
Figure 13. Active Output to High-Impedance Time, High Impedance to Active-Output Time . . . . .	25
Figure 14. 24-Bit Mode Serial-Data Format . . . . .	27
Figure 15. 27-Bit High-Bandwidth Mode Serial-Data Format . . . . .	28
Figure 16. 32-Bit Mode Serial-Data Format . . . . .	29
Figure 17. Coax Connection . . . . .	31
Figure 18. Crosspoint-Switch Dataflow . . . . .	31
Figure 19. State Diagram . . . . .	32
Figure 20. GMSL-UART Data Format for Base Mode . . . . .	66

Figure 21. GMSL-UART Protocol for Base Mode . . . . . 66

Figure 22. Sync Byte (0x79). . . . . 66

Figure 23. ACK Byte (0xC3). . . . . 66

Figure 24. Format Conversion Between GMSL UART and I<sup>2</sup>C with Register Address (I2CMETHOD = 0). . . . . 67

Figure 25. Format Conversion Between GMSL UART and I<sup>2</sup>C with Register Address (I2CMETHOD = 1). . . . . 67

Figure 26. Human Body Model ESD Test Circuit. . . . . 69

Figure 27. IEC 61000-4-2 Contact Discharge ESD Test Circuit . . . . . 69

Figure 28. ISO 10605 Contact Discharge ESD Test Circuit . . . . . 69

Table 1. Reverse Control-Channel Modes. . . . . 30

Table 2. Link-Startup Procedure . . . . . 33

Table 3. Output-Data Width Selection . . . . . 62

Table 4. Data-Rate Selection Table . . . . . 62

Table 5. Output Map (DBL = 0 or DBL = 1, First Word) . . . . . 63

Table 6. Output Map (DBL = 1, Second Word) . . . . . 64

Table 7. Legend . . . . . 64

Table 8. Default-Device Address . . . . . 68

Table 9. Cable-Equalizer Boost Levels . . . . . 68

Table 10. Feature Compatibility . . . . . 70

Table 11. Suggested Connectors and Cables for GMSL. . . . . 71

**Absolute Maximum Ratings**

AVDD to EP* .....	-0.5V to +1.9V	Operating Temperature Range .....	-40°C to +115°C
DVDD to EP* .....	-0.5V to +1.9V	Junction Temperature .....	+150°C
IOVDD to EP* .....	-0.5V to +3.9V	Storage Temperature Range .....	-40°C to +150°C
LMN_ to EP* (15mA current limit) .....	-0.5V to +3.9V	Soldering Temperature (reflow) .....	+260°C
IN_+, IN_- to EP* .....	-0.5V to +1.9V	Continuous Power Dissipation T <sub>A</sub> = +70°C, 32-pin TQFN/ SWTQFN (derate 34.5 mW/°C above +70°C.) .....	2758.6mW
All Other Pins to EP* .....	-0.5V to (IOVDD + 0.5V)V	<i>*EP connected to IC ground.</i>	
IN_+, IN_- Short Circuit to Ground or Supply .....	Continuous		

Stresses beyond those listed under "Absolute Maximum Ratings" may cause permanent damage to the device. These are stress ratings only, and functional operation of the device at these or any other conditions beyond those indicated in the operational sections of the specifications is not implied. Exposure to absolute maximum rating conditions for extended periods may affect device reliability.

**Package Thermal Characteristics**

For the latest package outline information and land patterns (footprints), go to [www.maximintegrated.com/packages](http://www.maximintegrated.com/packages). Note that a "+", "#", or "-" in the package code indicates RoHS status only. Package drawings may show a different suffix character, but the drawing pertains to the package regardless of RoHS status.

**32-Pin TQFN-EP**

PACKAGE CODE	T3255+8
Outline Number	<a href="#">21-0140</a>
Land Pattern Number	<a href="#">90-0013</a>
<b>Thermal Resistance, Single Layer Board:</b>	
Junction-to-Ambient (θ <sub>JA</sub> )	47
Junction-to-Case Thermal Resistance (θ <sub>JC</sub> )	1.7
<b>Thermal Resistance, Four Layer Board:</b>	
Junction-to-Ambient (θ <sub>JA</sub> )	29
Junction-to-Case Thermal Resistance (θ <sub>JC</sub> )	1.7

**32-Pin SWTQFN-EP**

PACKAGE CODE	T3255Y+8
Outline Number	<a href="#">21-100156</a>
Land Pattern Number	<a href="#">90-100067</a>
<b>Thermal Resistance, Single Layer Board:</b>	
Junction-to-Ambient (θ <sub>JA</sub> )	47
Junction-to-Case Thermal Resistance (θ <sub>JC</sub> )	1.7
<b>Thermal Resistance, Four Layer Board:</b>	
Junction-to-Ambient (θ <sub>JA</sub> )	29
Junction-to-Case Thermal Resistance (θ <sub>JC</sub> )	1.7

Package thermal resistances were obtained using the method described in JEDEC specification JESD51-7, using a four-layer board. For detailed information on package thermal considerations, refer to [www.maximintegrated.com/thermal-tutorial](http://www.maximintegrated.com/thermal-tutorial).

**DC Electrical Characteristics**

( $V_{DVDD} = V_{AVDD} = 1.7$  to  $1.9V$ ,  $V_{IOVDD} = 1.7V$  to  $3.6V$ ,  $R_L = 100\Omega \pm 1\%$  (differential), EP connected to PCB ground,  $T_A = -40^\circ C$  to  $+115^\circ C$ , Typical values are at,  $V_{DVDD} = V_{AVDD} = V_{IOVDD} = 1.8V$ ,  $T_A = +25^\circ C$ , unless otherwise noted.) (Note 1)

PARAMETER	SYM-BOL	CONDITIONS	MIN	TYP	MAX	UNITS
<b>SINGLE-ENDED INPUTS (GPI, CXTP, I2CSEL, ADD_, HIM, PWDNB, MS)</b>						
High-Level Input Voltage	$V_{IH1}$		$0.65 \times V_{IOVDD}$			V
Low-Level Input Voltage	$V_{IL1}$		$0.35 \times V_{IOVDD}$			V
Input Current	$I_{IN1}$	$V_{IN} = 0$ to $V_{IOVDD}$	-20		20	$\mu A$
<b>SINGLE-ENDED OUTPUTS (DOUT_, VS, HS, DE, PCLKOUT)</b>						
High-Level Output Voltage	$V_{OH1}$	$I_{OH} = -2mA$ , DCS = 0	$V_{IOVDD} - 0.3$			V
		$I_{OH} = -2mA$ , DCS = 1	$V_{IOVDD} - 0.2$			
Low-Level Output Voltage	$V_{OL1}$	$I_{OL} = 2mA$ , DCS = 0	0.3			V
		$I_{OL} = 2mA$ , DCS = 1	0.2			
High-Impedance Output Current	$I_{OZ}$	OUTENB = 1, $V_{OUT} = 0V$ or $V_{IOVDD}$	-20		20	$\mu A$
Output Short-Circuit Current	$I_{OS}$	DOUT_, $V_O = 0V$ , DCS = 0, $V_{IOVDD} = 3.0V$ to $3.6V$	15	25	39	mA
		DOUT_, $V_O = 0V$ , DCS = 0, $V_{IOVDD} = 1.7V$ to $1.9V$	3	7	13	
		DOUT_, $V_O = 0V$ , DCS = 1, $V_{IOVDD} = 3.0V$ to $3.6V$	20	35	63	
		DOUT_, $V_O = 0V$ , DCS = 1, $V_{IOVDD} = 1.7V$ to $1.9V$	5	10	21	
		PCLKOUT_, $V_O = 0V$ , DCS = 0, $V_{IOVDD} = 3.0V$ to $3.6V$	15	33	50	
		PCLKOUT_, $V_O = 0V$ , DCS = 0, $V_{IOVDD} = 1.7V$ to $1.9V$	5	10	17	
		PCLKOUT_, $V_O = 0V$ , DCS = 1, $V_{IOVDD} = 3.0V$ to $3.6V$	30	54	97	
		PCLKOUT_, $V_O = 0V$ , DCS = 1, $V_{IOVDD} = 1.7V$ to $1.9V$	9	16	32	

**DC Electrical Characteristics (continued)**

( $V_{DVDD} = V_{AVDD} = 1.7$  to  $1.9V$ ,  $V_{IOVDD} = 1.7V$  to  $3.6V$ ,  $R_L = 100\Omega \pm 1\%$  (differential), EP connected to PCB ground,  $T_A = -40^\circ C$  to  $+115^\circ C$ , Typical values are at,  $V_{DVDD} = V_{AVDD} = V_{IOVDD} = 1.8V$ ,  $T_A = +25^\circ C$ , unless otherwise noted.) (Note 1)

PARAMETER	SYM-BOL	CONDITIONS	MIN	TYP	MAX	UNITS
<b>UART/I<sup>2</sup>C and GENERAL-PURPOSE I/Os (RX/SDA, TX/SCL, GPIO_, ERRB, LOCK, LFLTb) with OPEN-DRAIN OUTPUTS</b>						
High-Level Input Voltage	$V_{IH2}$		0.7 x $V_{IOVDD}$			V
Low-Level Input Voltage	$V_{IL2}$			0.3 x $V_{IOVDD}$		V
Input Current	$I_{IN2}$	$V_{IN} = 0$ to $V_{IOVDD}$ (Note 2), RX/SDA, TX/SCL	-110		5	$\mu A$
	$I_{IN}$	$V_{IN} = 0$ to $V_{IOVDD}$ (Note 2), GPIO_, ERRB, LOCK	-80		5	
Low-Level Open-Drain Output Voltage	$V_{OL}$	$I_{OL} = 3mA$ , $V_{IOVDD} = 1.7V$ to $1.9V$			0.4	V
		$I_{OL} = 3mA$ , $V_{IOVDD} = 3.0V$ to $3.6V$			0.3	
Input Capacitance	$C_{IN}$	Each pin (Note 3)			10	pF
<b>OUTPUTS FOR REVERSE CONTROL CHANNEL (IN0+, IN0-, IN1+, IN1-)</b>						
Differential High-Output Peak Voltage ( $V_{IN+} - V_{IN-}$ )	$V_{RODH}$	Forward channel disabled, normal-immunity mode (Figure 1)	30		60	mV
		Forward channel disabled, high-immunity mode (Figure 1)	50		100	
Differential Low-Output Peak Voltage ( $V_{IN+} - V_{IN-}$ )	$V_{RODL}$	Forward channel disabled, normal-immunity mode (Figure 1)	-60		-30	mV
		Forward channel disabled, high-immunity mode (Figure 1)	-100		-50	
Single-Ended High-Output Peak Voltage	$V_{ROSH}$	Forward channel disabled, normal-immunity mode (Figure 1)	30		60	mV
		Forward channel disabled, high-immunity mode (Figure 1)	50		100	

**DC Electrical Characteristics (continued)**

( $V_{DVDD} = V_{AVDD} = 1.7$  to  $1.9V$ ,  $V_{IOVDD} = 1.7V$  to  $3.6V$ ,  $R_L = 100\Omega \pm 1\%$  (differential), EP connected to PCB ground,  $T_A = -40^\circ C$  to  $+115^\circ C$ , Typical values are at,  $V_{DVDD} = V_{AVDD} = V_{IOVDD} = 1.8V$ ,  $T_A = +25^\circ C$ , unless otherwise noted.) (Note 1)

PARAMETER	SYMBOL	CONDITIONS	MIN	TYP	MAX	UNITS
Single-Ended Low-Output Peak Voltage	$V_{ROSL}$	Forward channel disabled, normal-immunity mode (Figure 1)	-60		-30	mV
		Forward channel disabled, high-immunity mode (Figure 1)	-100		-50	
<b>DIFFERENTIAL INPUTS (IN0+, IN0-, IN1+, IN1-)</b>						
Differential High-Input Threshold Peak Voltage ( $V_{IN+} - V_{IN-}$ )	$V_{IDH(P)}$	Activity detector, medium threshold (0x22 D[6:5] = 01) (Figure 2)			60	mV
		Activity detector, low threshold (0x22 D[6:5] = 00) (Figure 2)			49	
Differential Low-Input Threshold Peak Voltage ( $V_{IN+} - V_{IN-}$ )	$V_{IDL(P)}$	Activity detector, medium threshold (0x22 D[6:5] = 01) (Figure 2)	-60			mV
		Activity detector, low threshold (0x22 D[6:5] = 00) (Figure 2)	-49			
Input Common-Mode Voltage ( $(V_{IN+} + V_{IN-})/2$ )	$V_{CMR}$		1	1.3	1.6	V
Differential-Input Resistance (Internal)	$R_I$		80	100	130	$\Omega$
<b>SINGLE-ENDED INPUTS (IN0+, IN0-, IN1+, IN1-)</b>						
Single-Ended High-Input Threshold Peak Voltage	$V_{ISH(P)}$	Activity detector, medium threshold (0x22 D[6:5] = 01) (Figure 3)			43	mV
		Activity detector, low threshold (0x22 D[6:5] = 00) (Figure 3)			33	
Single-Ended Low-Input Threshold Peak Voltage	$V_{ISL(P)}$	Activity detector, medium threshold (0x22 D[6:5] = 01) (Figure 3)	-43			mV
		Activity detector, low threshold (0x22 D[6:5] = 00) (Figure 3)	-33			
Input Resistance (Internal)	$R_I$		40	50	65	$\Omega$
<b>LINE FAULT DETECTION INPUTS (LMN0, LMN1)</b>						
Short-to-Ground Threshold	$V_{TG}$	(Figure 4)			0.3	V
Normal Threshold	$V_{TN}$	(Figure 4)	0.57		1.07	V
Open Threshold	$V_{TO}$	(Figure 4)	1.45		$V_{IO} + 0.06$	V
Open-Input Voltage	$V_{IO}$	(Figure 4)	1.47		1.75	V
Short-to-Battery Threshold	$V_{TE}$	(Figure 4)	2.47			V

**DC Electrical Characteristics (continued)**

( $V_{DVDD} = V_{AVDD} = 1.7$  to  $1.9V$ ,  $V_{IOVDD} = 1.7V$  to  $3.6V$ ,  $R_L = 100\Omega \pm 1\%$  (differential), EP connected to PCB ground,  $T_A = -40^\circ C$  to  $+115^\circ C$ , Typical values are at,  $V_{DVDD} = V_{AVDD} = V_{IOVDD} = 1.8V$ ,  $T_A = +25^\circ C$ , unless otherwise noted.) (Note 1)

PARAMETER	SYM-BOL	CONDITIONS	MIN	TYP	MAX	UNITS
<b>POWER SUPPLY</b>						
Worst-Case Supply Current (Figure 5)	$I_{WCS}$	$f_{PCLKOUT} = 116MHz$ , HIBW = 1, BWS = 0, double output, AVDD + DVDD (1.9V)		100	120	mA
		$f_{PCLKOUT} = 116MHz$ , HIBW = 0, BWS = 0, double output, AVDD + DVDD (1.9V)		95	115	
		$f_{PCLKOUT} = 116MHz$ , BWS = 0, double output, IOVDD (1.9V), $C_L = 5pF$ (DCS = 0) (Note 3)		22	25	
		$f_{PCLKOUT} = 116MHz$ , BWS = 0, double output, IOVDD (1.9V), $C_L = 10pF$ (DCS = 1) (Note 3)		31	35	
		$f_{PCLKOUT} = 116MHz$ , BWS = 0, double output, IOVDD (3.6V), $C_L = 5pF$ (DCS = 0) (Note 3)		44	49	
		$f_{PCLKOUT} = 116MHz$ , BWS = 0, double output, IOVDD (3.6V), $C_L = 10pF$ (DCS = 1) (Note 3)		63	70	
		$f_{PCLKOUT} = 87MHz$ , BWS = 1, double output, IOVDD (1.9V), AVDD + DVDD (1.9V)		95	115	
		$f_{PCLKOUT} = 87MHz$ , BWS = 1, double output, IOVDD (1.9V), $C_L = 5pF$ (DCS = 0) (Note 3)		17	19	
		$f_{PCLKOUT} = 87MHz$ , BWS = 1, double output, IOVDD (1.9V), $C_L = 10pF$ (DCS = 1) (Note 3)		24	27	
		$f_{PCLKOUT} = 87MHz$ , BWS = 1, double output, IOVDD (3.6V), $C_L = 5pF$ (DCS = 0) (Note 3)		33	36	
		$f_{PCLKOUT} = 87MHz$ , BWS = 1, double output, IOVDD (3.6V), $C_L = 10pF$ (DCS = 1) (Note 3)		44	49	
		$f_{PCLKOUT} = 58MHz$ , HIBW = 1, BWS = 0, single output, AVDD + DVDD (1.9V)		70	84	
		$f_{PCLKOUT} = 58MHz$ , HIBW = 0, BWS = 0, single output, AVDD + DVDD (1.9V)		70	84	
		$f_{PCLKOUT} = 58MHz$ , BWS = 0, single output, IOVDD (1.9V), $C_L = 5pF$ (DCS = 0) (Note 3)		11	13	
		$f_{PCLKOUT} = 58MHz$ , BWS = 0, single output, IOVDD (3.6V), $C_L = 10pF$ (DCS = 1) (Note 3)		15	18	

**DC Electrical Characteristics (continued)**

( $V_{DVDD} = V_{AVDD} = 1.7$  to  $1.9V$ ,  $V_{IOVDD} = 1.7V$  to  $3.6V$ ,  $R_L = 100\Omega \pm 1\%$  (differential), EP connected to PCB ground,  $T_A = -40^\circ C$  to  $+115^\circ C$ , Typical values are at,  $V_{DVDD} = V_{AVDD} = V_{IOVDD} = 1.8V$ ,  $T_A = +25^\circ C$ , unless otherwise noted.) (Note 1)

PARAMETER	SYM-BOL	CONDITIONS	MIN	TYP	MAX	UNITS
<b>POWER SUPPLY (continued)</b>						
Worst-Case Supply Current (Figure 5) (continued)	$I_{WCS}$	$f_{PCLKOUT} = 58MHz$ , BWS = 0, single output, IOVDD (3.6V), $C_L = 5pF$ (DCS = 0) (Note 3)		22	25	mA
		$f_{PCLKOUT} = 58MHz$ , BWS = 0, single output, IOVDD (3.6V), $C_L = 10pF$ (DCS = 1) (Note 3)		30	34	
		$f_{PCLKOUT} = 43.5MHz$ , BWS = 1, single output, AVDD + DVDD (1.9V)		70	84	
		$f_{PCLKOUT} = 43.5MHz$ , BWS = 1, single output, IOVDD (1.9V), $C_L = 5pF$ (DCS = 0) (Note 3)		8	10	
		$f_{PCLKOUT} = 43.5MHz$ , BWS = 1, single output, IOVDD (1.9V), $C_L = 10pF$ (DCS = 1) (Note 3)		12	14	
		$f_{PCLKOUT} = 43.5MHz$ , BWS = 1, single output, IOVDD (3.6V), $C_L = 5pF$ (DCS = 0) (Note 3)		16	18	
		$f_{PCLKOUT} = 43.5MHz$ , BWS = 1, single output, IOVDD (3.6V), $C_L = 10pF$ (DCS = 1) (Note 3)		22	25	
Sleep-Mode Supply Current	$I_{CCS}$	Wake-up receivers enabled		54	160	$\mu A$
		Wake-up receivers disabled		15	100	
Power-Down Supply Current	$I_{CCZ}$	PWDNB = low		15	100	$\mu A$
<b>ESD PROTECTION</b>						
IN+, IN- (Note 4)	$V_{ESD}$	Human Body Model, $R_D = 1.5k\Omega$ , $C_S = 100pF$		$\pm 8$		kV
		IEC 61000-4-2, $R_D = 330\Omega$ , $C_S = 150pF$ , Contact discharge		$\pm 10$		
		IEC 61000-4-2, $R_D = 330\Omega$ , $C_S = 150pF$ , Air discharge		$\pm 15$		
		ISO 10605, $R_D = 2k\Omega$ , $C_S = 330pF$ , Contact discharge		$\pm 10$		
		ISO 10605, $R_D = 2k\Omega$ , $C_S = 330pF$ , Air discharge		$\pm 30$		
All Other Pins (Note 5)	$V_{ESD}$	Human Body Model, $R_D = 1.5k\Omega$ , $C_S = 100pF$		$\pm 4$		kV
		Machine Model		250		V

**AC Electrical Characteristics**

(V<sub>DVDD</sub> = V<sub>AVDD</sub> = 1.7 to 1.9V, V<sub>IOVDD</sub> = 1.7V to 3.6V, R<sub>L</sub> = 100Ω ±1% (differential), EP connected to PCB ground, T<sub>A</sub> = -40°C to +115°C, Typical values are at, V<sub>DVDD</sub> = V<sub>AVDD</sub> = V<sub>IOVDD</sub> = 1.8V, T<sub>A</sub> = +25°C, unless otherwise noted.) (Note 1)

PARAMETER	SYM-BOL	CONDITIONS	MIN	TYP	MAX	UNITS
<b>PARALLEL CLOCK OUTPUT (PCLKOUT)</b>						
Clock Frequency	f <sub>PCLKOUT</sub>	BWS = 1, DRS = 1, single output	6.25		12.5	MHz
		BWS = 0, DRS = 1, single output	8.33		16.66	
		BWS = 1, DRS = 0, single output	12.5		43.5	
		BWS = 0, HIBW = 0, DRS = 0, single output	16.66		58	
		BWS = 0, HIBW = 1, DRS = 0, single output	36.66		58	
		BWS = 1, DRS = 0, double output	25		87	
		BWS = 0, HIBW = 0, DRS = 0, double output	33.33		116	
		BWS = 0, HIBW = 1, DRS = 0, double output	73.33		116	
Data Valid Before Clock	t <sub>DVB</sub>	PCLKOUT and DOUT <sub>+</sub> , DCS = 1, C <sub>L</sub> = 10pF or DCS = 0, C <sub>L</sub> = 5pF, nonstaggered DOUT <sub>+</sub>	0.4T	0.5T		ns
		PCLKOUT and DOUT <sub>+</sub> , DCS = 1, C <sub>L</sub> = 10pF or DCS = 0, C <sub>L</sub> = 5pF, staggered DOUT <sub>+</sub>	0.35T	0.4T		
Data Valid After Clock	t <sub>DVA</sub>	PCLKOUT and DOUT <sub>+</sub> , DCS = 1, C <sub>L</sub> = 10pF or DCS = 0, C <sub>L</sub> = 5pF, nonstaggered DOUT <sub>+</sub>	0.35T	0.4T		ns
		PCLKOUT and DOUT <sub>+</sub> , DCS = 1, C <sub>L</sub> = 10pF or DCS = 0, C <sub>L</sub> = 5pF, staggered DOUT <sub>+</sub>	0.3T	0.35T		
Clock Jitter	t <sub>J</sub>	RMS period jitter, spread off, 1.74Gbps PRBS pattern, UI = 1/f <sub>PCLKOUT</sub> , DBL = 1, double output)		0.05		UI
		Period jitter; peak-to-peak, spread off, 1.74Gbps, PRBS pattern, UI = 1/f <sub>PCLKOUT</sub> , DBL = 0, single output)		0.01		
<b>I<sup>2</sup>C/UART PORT TIMING</b>						
I <sup>2</sup> C/UART Bit Rate			9.6		1000	kbps
Output Rise Time	t <sub>R</sub>	30% to 70%, C <sub>L</sub> = 10pF to 100pF, 1kΩ pullup to IOVDD	20		150	ns
Output Fall Time	t <sub>F</sub>	70% to 30%, C <sub>L</sub> = 10pF to 100pF, 1kΩ pullup to IOVDD	20		150	ns

AC Electrical Characteristics (continued)

( $V_{DVDD} = V_{AVDD} = 1.7$  to  $1.9V$ ,  $V_{IOVDD} = 1.7V$  to  $3.6V$ ,  $R_L = 100\Omega \pm 1\%$  (differential), EP connected to PCB ground,  $T_A = -40^\circ C$  to  $+115^\circ C$ , Typical values are at,  $V_{DVDD} = V_{AVDD} = V_{IOVDD} = 1.8V$ ,  $T_A = +25^\circ C$ , unless otherwise noted.) (Note 1)

PARAMETER	SYM-BOL	CONDITIONS	MIN	TYP	MAX	UNITS
<b>I<sup>2</sup>C TIMING (Figure 6)</b>						
SCL Clock Frequency	f <sub>SCL</sub>	Low f <sub>SCL</sub> range: (I2CMSTBT = 010, I2CSLVSH = 10)	9.6		100	kHz
		Mid f <sub>SCL</sub> range: (I2CMSTBT 101, I2CSLVSH = 01)	>100		400	
		High f <sub>SCL</sub> range: (I2CMSTBT = 111, I2CSLVSH = 00)	>400		1000	
START Condition Hold Time	t <sub>HD:STA</sub>	f <sub>SCL</sub> range, Low	4			μs
		f <sub>SCL</sub> range, Mid	0.6			
		f <sub>SCL</sub> range, High	0.26			
Low Period of SCL Clock	t <sub>LOW</sub>	f <sub>SCL</sub> range, Low	4.7			μs
		f <sub>SCL</sub> range, Mid	1.3			
		f <sub>SCL</sub> range, High	0.5			
High Period of SCL Clock	t <sub>HIGH</sub>	f <sub>SCL</sub> range, Low	4			μs
		f <sub>SCL</sub> range, Mid	0.6			
		f <sub>SCL</sub> range, High	0.26			
Repeated START Condition Setup Time	t <sub>SU:STA</sub>	f <sub>SCL</sub> range, Low	4.7			μs
		f <sub>SCL</sub> range, Mid	0.6			
		f <sub>SCL</sub> range, High	0.26			
Data Hold Time	t <sub>HD:DAT</sub>	f <sub>SCL</sub> range, Low	0			ns
		f <sub>SCL</sub> range, Mid	0			
		f <sub>SCL</sub> range, High	0			
Data Setup Time	t <sub>SU:DAT</sub>	f <sub>SCL</sub> range, Low	250			ns
		f <sub>SCL</sub> range, Mid	100			
		f <sub>SCL</sub> range, High	50			
Setup Time for STOP Condition	t <sub>SU:STO</sub>	f <sub>SCL</sub> range, Low	4			μs
		f <sub>SCL</sub> range, Mid	0.6			
		f <sub>SCL</sub> range, High	0.26			
Bus Free Time	t <sub>BUF</sub>	f <sub>SCL</sub> range, Low	4.7			μs
		f <sub>SCL</sub> range, Mid	1.3			
		f <sub>SCL</sub> range, High	0.5			
Data Valid Time	t <sub>VD:DAT</sub>	f <sub>SCL</sub> range, Low			3.45	μs
		f <sub>SCL</sub> range, Mid			0.9	
		f <sub>SCL</sub> range, High			0.45	
Data Valid Acknowledge Time	t <sub>VD:ACK</sub>	f <sub>SCL</sub> range, Low			3.45	μs
		f <sub>SCL</sub> range, Mid			0.9	
		f <sub>SCL</sub> range, High			0.45	

**AC Electrical Characteristics (continued)**

( $V_{DVDD} = V_{AVDD} = 1.7$  to  $1.9V$ ,  $V_{IOVDD} = 1.7V$  to  $3.6V$ ,  $R_L = 100\Omega \pm 1\%$  (differential), EP connected to PCB ground,  $T_A = -40^\circ C$  to  $+115^\circ C$ , Typical values are at,  $V_{DVDD} = V_{AVDD} = V_{IOVDD} = 1.8V$ ,  $T_A = +25^\circ C$ , unless otherwise noted.) (Note 1)

PARAMETER	SYM-BOL	CONDITIONS	MIN	TYP	MAX	UNITS
Pulse Width of Spikes Suppressed	$t_{SP}$	$f_{SCL}$ range, Low			50	ns
		$f_{SCL}$ range, Mid			50	
		$f_{SCL}$ range, High			50	
Capacitive load each bus line	$C_B$				100	pF
<b>SWITCHING CHARACTERISTICS (Note 3)</b>						
PCLKOUT Rise-and-Fall Time (Figure 7)	$t_R, t_F$	20% to 80%, $V_{IOVDD} = 1.7V$ to $1.9V$ , DCS = 1, $C_L = 10pF$	0.4		2.2	ns
		20% to 80%, $V_{IOVDD} = 1.7V$ to $1.9V$ , DCS = 0, $C_L = 5pF$	0.5		2.8	
		20% to 80%, $V_{IOVDD} = 3.0V$ to $3.6V$ , DCS = 1, $C_L = 10pF$	0.25		1.8	
		20% to 80%, $V_{IOVDD} = 3.0V$ to $3.6V$ , DCS = 0, $C_L = 5pF$	0.3		2	
Parallel Data Rise-and-Fall Time (Figure 7)	$t_R, t_F$	20% to 80%, $V_{IOVDD} = 1.7V$ to $1.9V$ , DCS = 1, $C_L = 10pF$	0.5		3.1	ns
		20% to 80%, $V_{IOVDD} = 1.7V$ to $1.9V$ , DCS = 0, $C_L = 5pF$	0.6		3.8	
		20% to 80%, $V_{IOVDD} = 3.0V$ to $3.6V$ , DCS = 1, $C_L = 10pF$	0.3		2.2	
		20% to 80%, $V_{IOVDD} = 3.0V$ to $3.6V$ , DCS = 0, $C_L = 5pF$	0.4		2.4	
Deserializer Delay	$t_{SD}$	(Figure 8) (Note 6)			2160	Bits
Reverse Control-Channel Output Rise Time	$t_R$	No forward-channel data transmission	180		400	ns
Reverse Control-Channel Output Fall Time	$t_F$	No forward-channel data transmission	180		400	ns
GPI-to-GPO Delay	$t_{GPIO}$	Deserializer GPI to serializer GPO (Figure 9)			350	$\mu s$
Lock Time (Note 3)	$t_{LOCK}$	(Figure 10) AEQ on, packet CC off			1.6	ms
		(Figure 10) AEQ on, packet CC on			4.1	
		(Figure 10) AEQ off, packet CC off			1	
		(Figure 10) AEQ off, packet CC on			3.5	
Power-Up Time	$t_{PU}$	(Figure 11)			6.5	ms
Active Output to High-Impedance Time	$t_{OAZ}$	(Figure 12, Figure 13) CC write OUTENB = 1			250	ns
Active High-Impedance to Output Time	$t_{OZA}$	(Figure 12, Figure 13) CC write OUTENB = 0			250	ns

**Note 1:** Limits are 100% production tested at  $T_A = +115^\circ C$ . Limits over the operating temperature range are guaranteed by design and characterization, unless otherwise noted.

**Note 2:**  $I_{IN}$  min is due to voltage drop across the internal pullup resistor.

**Note 3:** Not production tested. Guaranteed by design.

**Note 4:** Specified pin to ground.

**Note 5:** Specified pin to all supply/ground.

**Note 6:** Measured in serial link bit times. Bit time =  $1/(30 \times f_{PCLKOUT})$  for BWS = GND. Bit time =  $1/(40 \times f_{PCLKOUT})$  for BWS = 1.

Typical Operating Characteristics

( $V_{AVDD} = V_{DVDD} = V_{IOVDD} = 1.8V$ ,  $T_A = +25^\circ C$ , unless otherwise noted.)

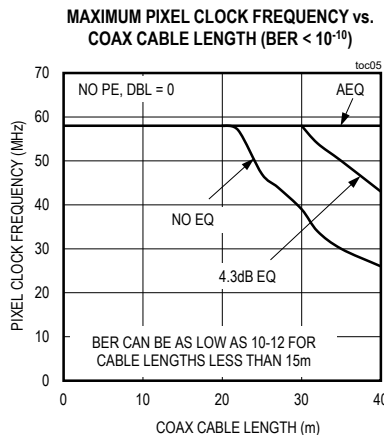
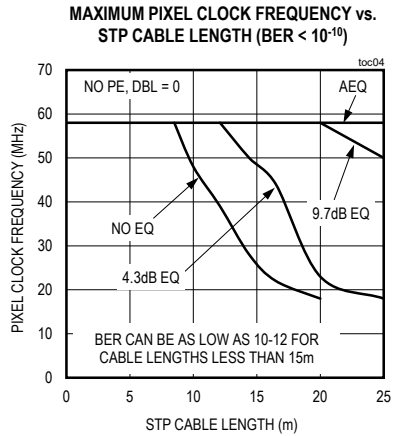
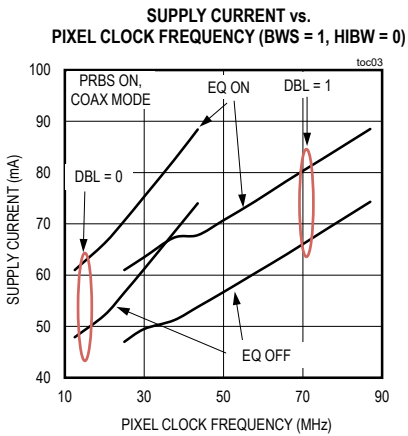
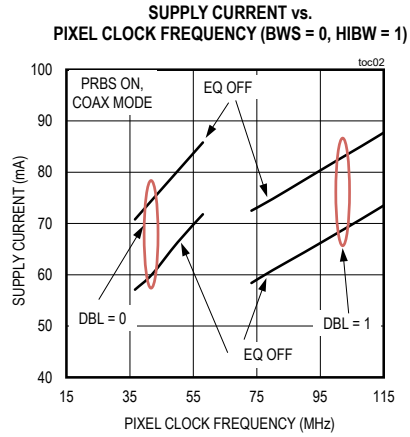
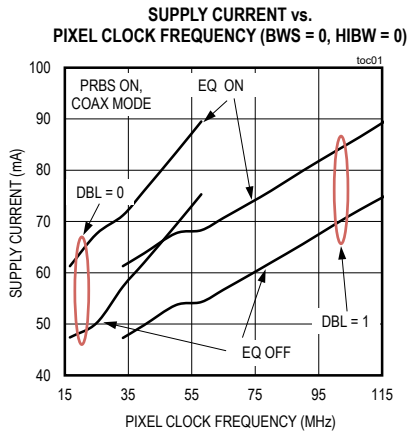

Pin Configuration

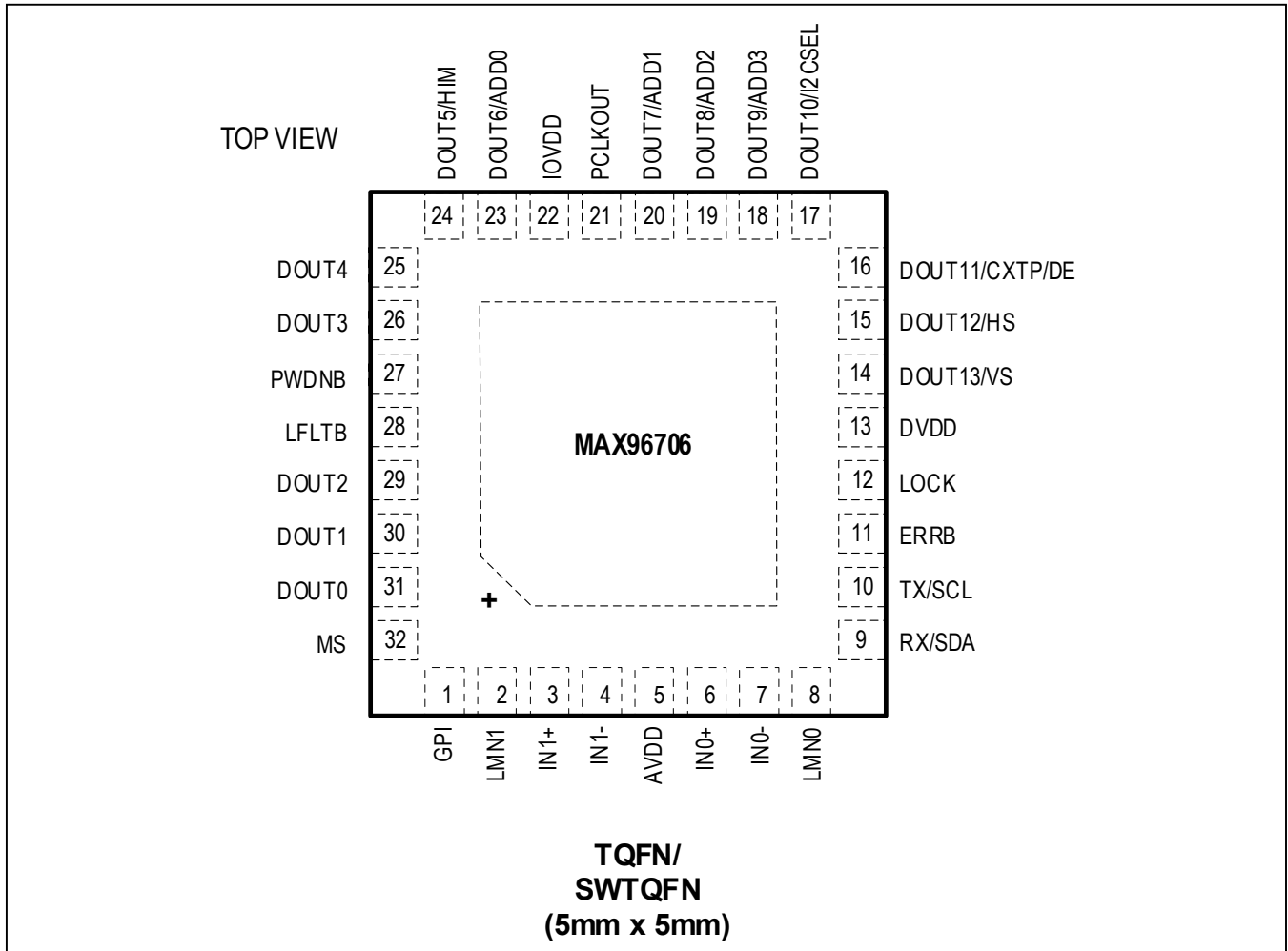

## Pin Description

PIN	NAME	FUNCTION	REF SUPPLY	TYPE
<b>POWER</b>				
5	AVDD	1.8V Analog Power Supply. Bypass AVDD to EP with 0.1 $\mu$ F and 0.001 $\mu$ F capacitors placed as close as possible to the device, with the smaller-value capacitor closest to AVDD.		Power
13	DVDD	1.8V Digital Power Supply. Bypass DVDD to EP with 0.1 $\mu$ F and 0.001 $\mu$ F capacitors placed as close as possible to the device, with the smaller-value capacitor closest to DVDD.		Power
22	IOVDD	I/O Supply Voltage. 1.8V to 3.3V logic I/O power supply. Bypass IOVDD to EP with 0.1 $\mu$ F and 0.001 $\mu$ F capacitors placed as close as possible to the device, with the smaller-value capacitor closest to IOVDD.		Power
EP	—	Exposed Pad. EP is internally connected to device ground. Must connect EP to the PCB ground plane through a via array for proper thermal and electrical performance.		Power
<b>HIGH-SPEED DIGITAL</b>				
<b>High-Speed Digital / Multifunction</b>				
14	DOUT13/VS	Parallel-Data/Vertical-Sync Output. Defaults to parallel-data output on power-up. Vertical-sync output when HS/VS encoding is enabled, or when in high-bandwidth mode.	IOVDD	Digital
15	DOUT12/HS	Parallel-Data/Horizontal-Sync Output. Defaults to parallel-data output on power-up. Horizontal-sync output when HS/VS encoding is enabled, or when in high-bandwidth mode.	IOVDD	Digital
16	DOUT11/ CXTP/DE	Parallel-Data Output/Cable-Type Input/Data-Enable Output with internal pulldown to EP. CX/TP is latched at power-up, or when resuming from power-down mode (PWDNB = low), and switches to parallel/data-enable output after power-up. Connect CXTP to IOVDD with a 30k $\Omega$ resistor to set high (coax mode), or leave open to set low (twisted-pair mode). Data-enable output when HIBW = 1.	IOVDD	Digital
17	DOUT10/ I2CSEL	Parallel-Data Output/I <sup>2</sup> C-Select Input with Internal Pulldown to EP. I2CSEL is latched at power-up, or when resuming from power-down mode (PWDNB = low), and switches to parallel-data output after power-up. Connect I2CSEL to IOVDD with a 30k $\Omega$ resistor to set high (I <sup>2</sup> C interface), or leave open to set low (UART interface).	IOVDD	Digital
18	DOUT9/ ADD3	Parallel-Data Output/Address Input with Internal Pulldown to EP. ADD3 is latched at power-up, or when resuming from power-down mode (PWDNB = low), and switches to parallel-data output after power-up. Connect ADD3 to IOVDD with a 30k $\Omega$ resistor to set high, or leave open to set low.	IOVDD	Digital
19	DOUT8/ ADD2	Parallel-Data Output/Address Input with Internal Pulldown to EP. ADD2 is latched at power-up, or when resuming from power-down mode (PWDNB = low), and switches to parallel-data output after power-up. Connect ADD2 to IOVDD with a 30k $\Omega$ resistor to set high, or leave open to set low.	IOVDD	Digital

## Pin Description (continued)

PIN	NAME	FUNCTION	REF SUPPLY	TYPE
20	DOUT7/ ADD1	Parallel-Data Output/Address Input with Internal Pulldown to EP. ADD1 is latched at power-up, or when resuming from power-down mode (PWDNB = low), and switches to parallel-data output after power-up. Connect ADD1 to IOVDD with a 30kΩ resistor to set high, or leave open to set low.	IOVDD	Digital
23	DOUT6/ ADD0	Parallel-Data Output/Address Input with Internal Pulldown to EP. ADD0 is latched at power-up, or when resuming from power-down mode (PWDNB = low), and switches to parallel-data output after power-up. Connect ADD0 to IOVDD with a 30kΩ resistor to set high, or leave open to set low.	IOVDD	Digital
24	DOUT5/HIM	Parallel-Data Output/High-Immunity Mode Input with Internal Pulldown to EP. HIM input latched at power-up, or when resuming from power-down mode (PWDNB = low), and switches to parallel-data output after power-up. Connect HIM to IOVDD with a 30kΩ resistor to set high, or leave open to set low. HIGHIMM in the serializer must be set to the same value.	IOVDD	Digital
<b>High-Speed Digital / Single-Function</b>				
21	PCLKOUT	Parallel-Clock Output. Provides timing signal to latch parallel-data outputs to the input of another device.	IOVDD	Digital
25	DOUT4	Parallel-Data Output	IOVDD	Digital
26	DOUT3	Parallel-Data Output	IOVDD	Digital
29	DOUT2	Parallel-Data Output	IOVDD	Digital
30	DOUT1	Parallel-Data Output	IOVDD	Digital
31	DOUT0	Parallel-Data Output	IOVDD	Digital
<b>LINE FAULT</b>				
2	LMN1	Line-Fault Monitor Input 1 (see <a href="#">Figure 4</a> )		Analog
8	LMN0	Line-Fault Monitor Input 0 ) (see <a href="#">Figure 4</a> )		Analog
28	LFLTB	Line-Fault Output. LFLTB is active low, and has a 60kΩ internal pullup to IOVDD. LFLTB low indicates a line-fault condition at LMN0, or LMN1. LFLTB is output high when PWDNB is low.	IOVDD	Digital

## Pin Description (continued)

PIN	NAME	FUNCTION	REF SUPPLY	TYPE
<b>OTHER PINS</b>				
1	GPI	General-Purpose Input with Internal Pulldown to EP. Serializer GPO (or INT) output follows the state of the GPI.	IOVDD	Digital
3	IN1+	Noninverting CML Serial-Data Input 1. Coax input when CXTP is high.		
4	IN1-	Inverting CML Serial-Data Input 1		
6	IN0+	Noninverting CML Serial-Data Input 0. Coax input when CXTP is high.		
7	IN0-	Inverting CML Serial-Data Input 0		
9	RX/SDA	Receive/Serial Data. Input/output with internal 30kΩ pullup to IOVDD. In UART mode, RX/SDA is the Rx input of the serializer's UART. In I <sup>2</sup> C mode, RX/SDA is the SDA input/output of the serializer's I <sup>2</sup> C master/slave. RX/SDA has an open-drain driver and requires a pullup resistor.	IOVDD	Digital
10	TX/SCL	Transmit/Serial Clock. Input/output with internal 30kΩ pullup to IOVDD. In UART mode, TX/SCL is the Tx output of the serializer's UART. In I <sup>2</sup> C mode, TX/SCL is the SCL input/output of the serializer's I <sup>2</sup> C master/slave. TX/SCL has an open-drain driver and requires a pullup resistor.	IOVDD	Digital
11	ERRB	Error Output. Active-low, open-drain video data error output with internal pullup to IOVDD. ERRB goes low when decoding errors during normal operation exceed a programmed threshold, or when at least one PRBS error is detected during a PRBS test. ERRB is output high when PWDNB is low.	IOVDD	Digital
12	LOCK	Lock Output. Open-drain output with internal pullup to IOVDD. LOCK high indicates PLLs are locked with correct serial-word boundary alignment. LOCK low indicates PLLs are not locked, or incorrect serial-word boundary alignment. LOCK is low when the configuration link is active. LOCK is output high when PWDNB is low.	IOVDD	Digital
27	PWDNB	Active-Low, Power-Down Input with Internal Pulldown to EP. Set PWDNB low to enter power-down mode to reduce power consumption.	IOVDD	Digital
32	MS	Mode-select Input with Internal Pulldown to EP. Set MS low to select base mode. Set MS high to select bypass mode.	IOVDD	Digital

Functional Diagrams

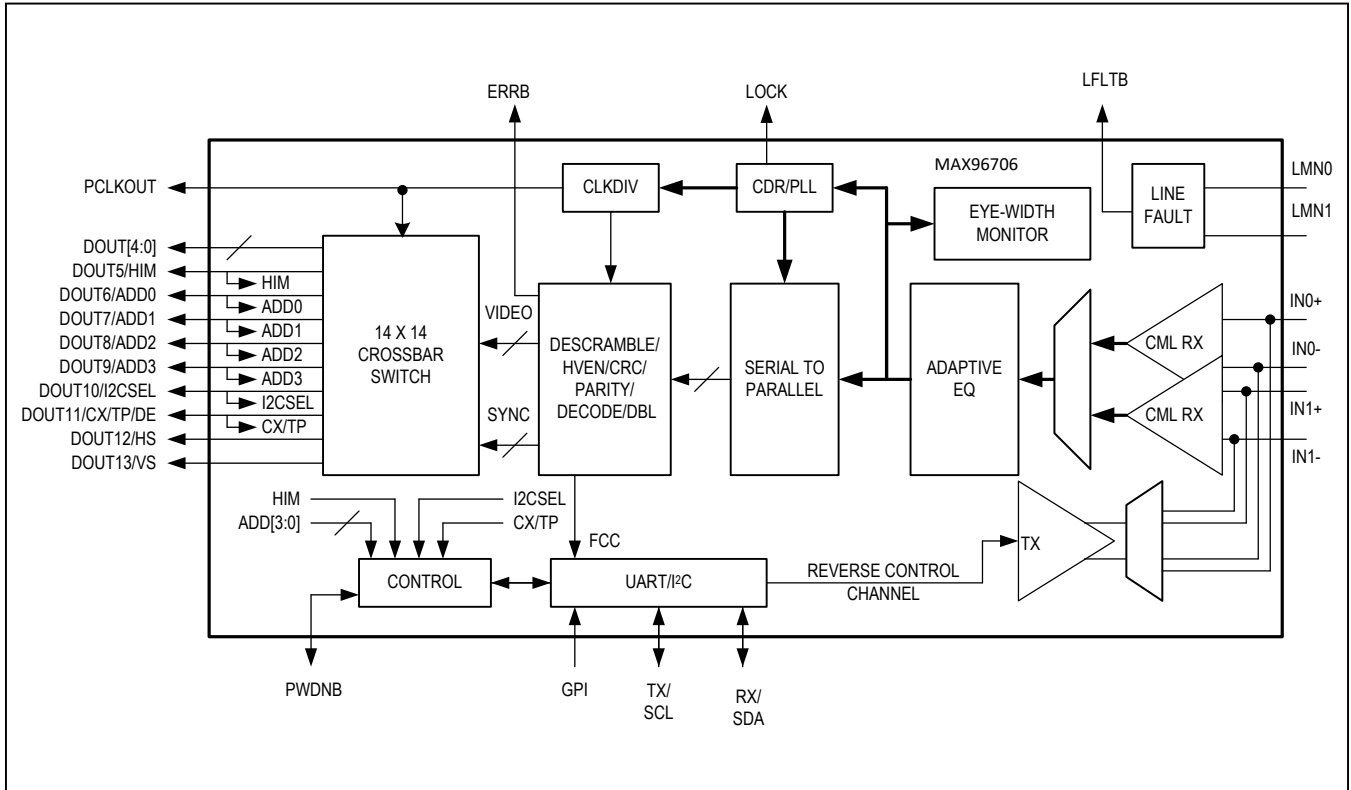

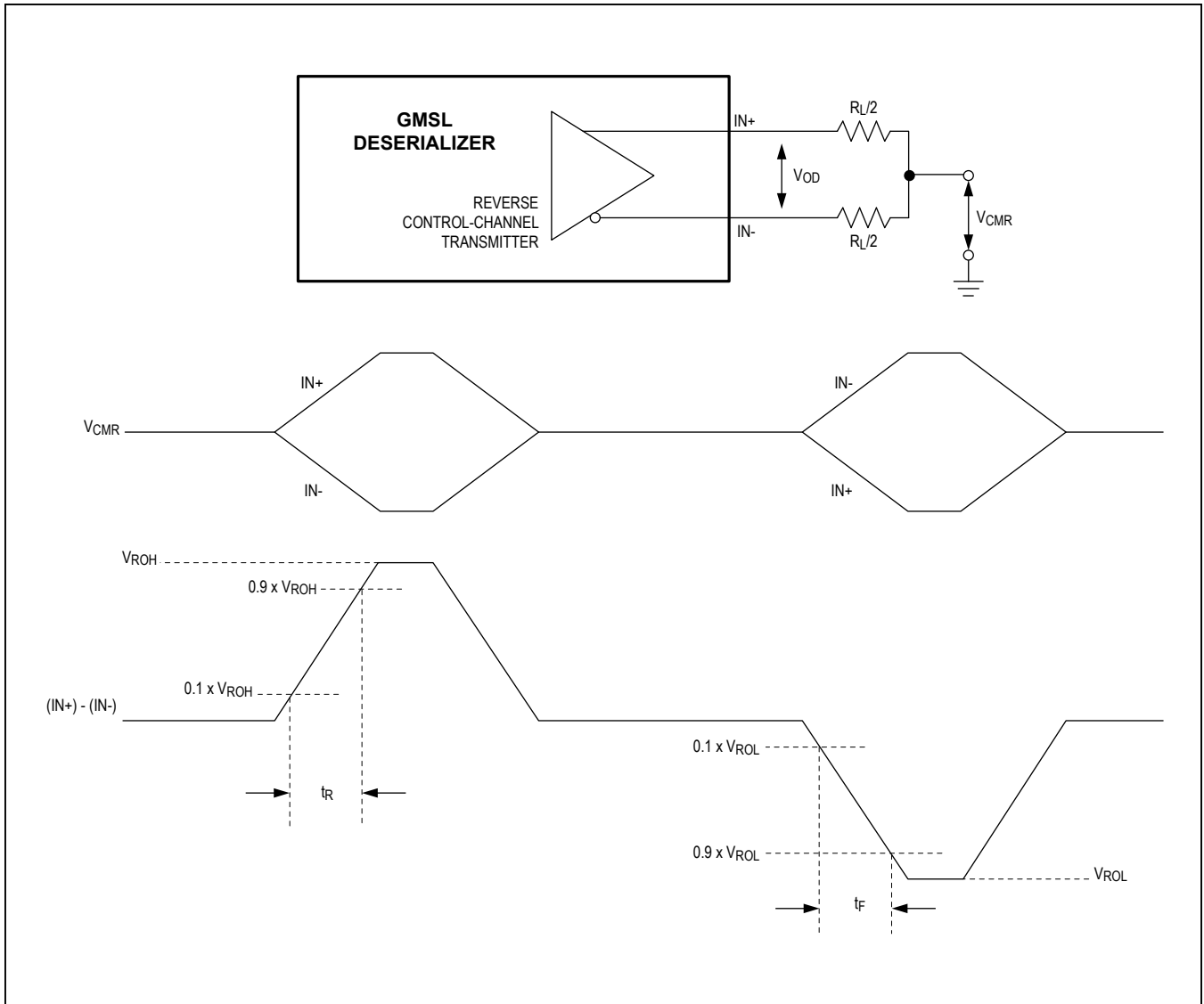

Figure 1. Reverse Control-Channel Output Parameters

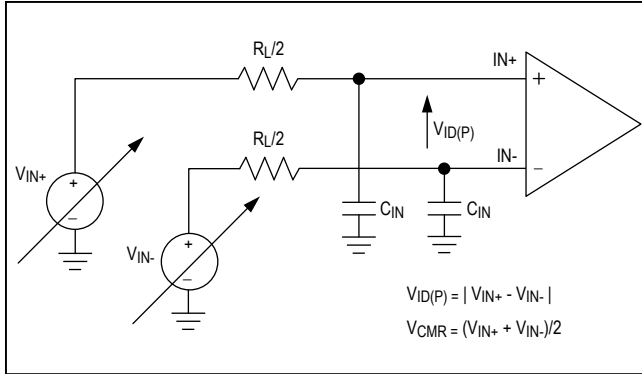

Figure 2. Test Circuit for Differential Input Measurement

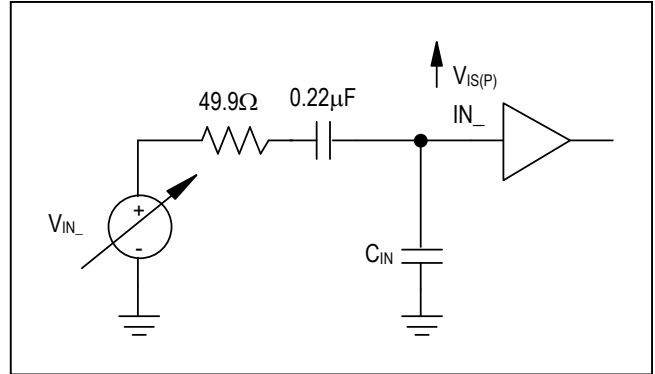

Figure 3. Test Circuit for Single-Ended Input Measurement

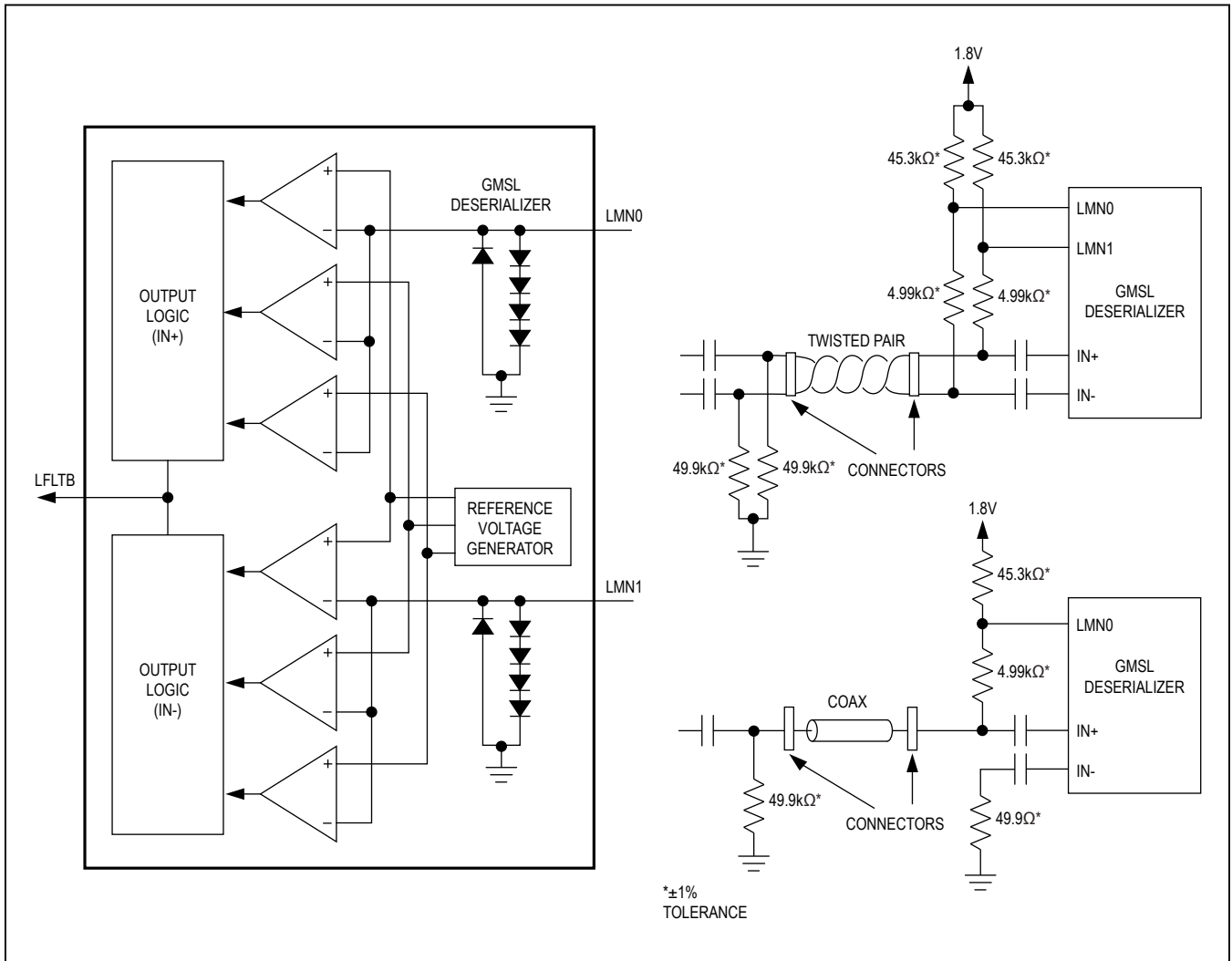

Figure 4. Line Fault

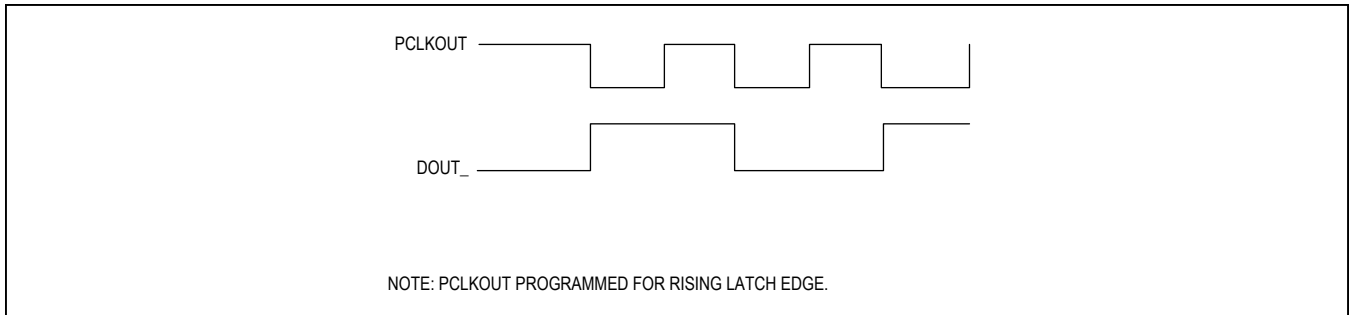

Figure 5. Worst-Case Pattern Output

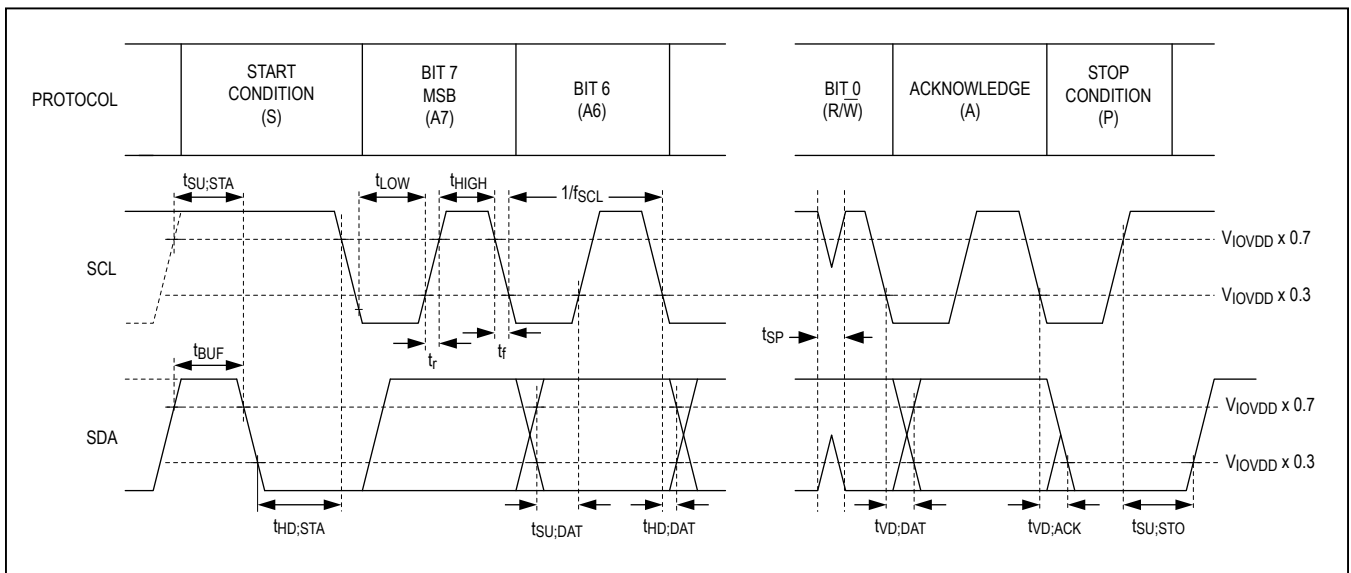

Figure 6. I<sup>2</sup>C Timing Parameters

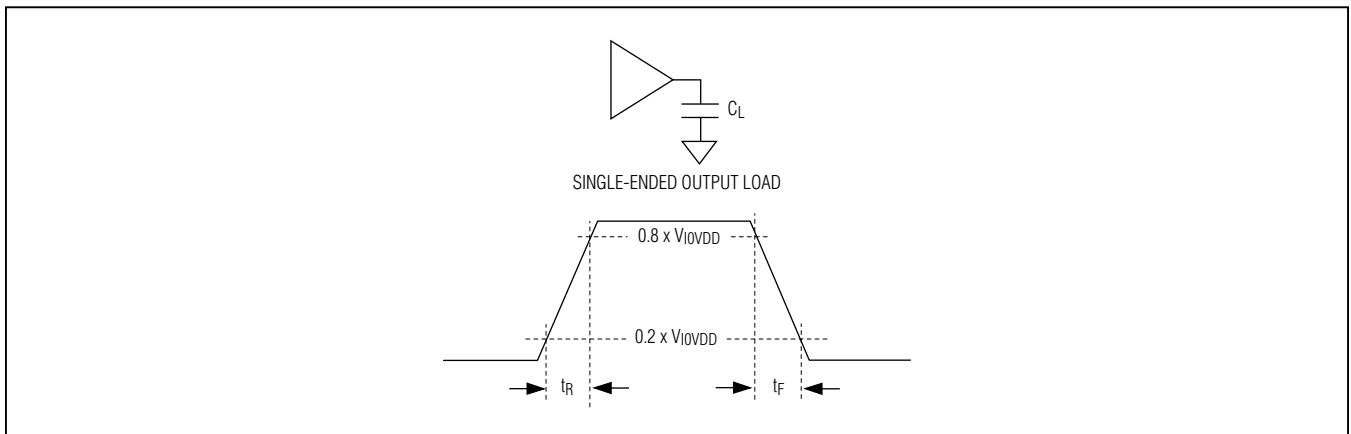

Figure 7. Output Rise-and-Fall Times

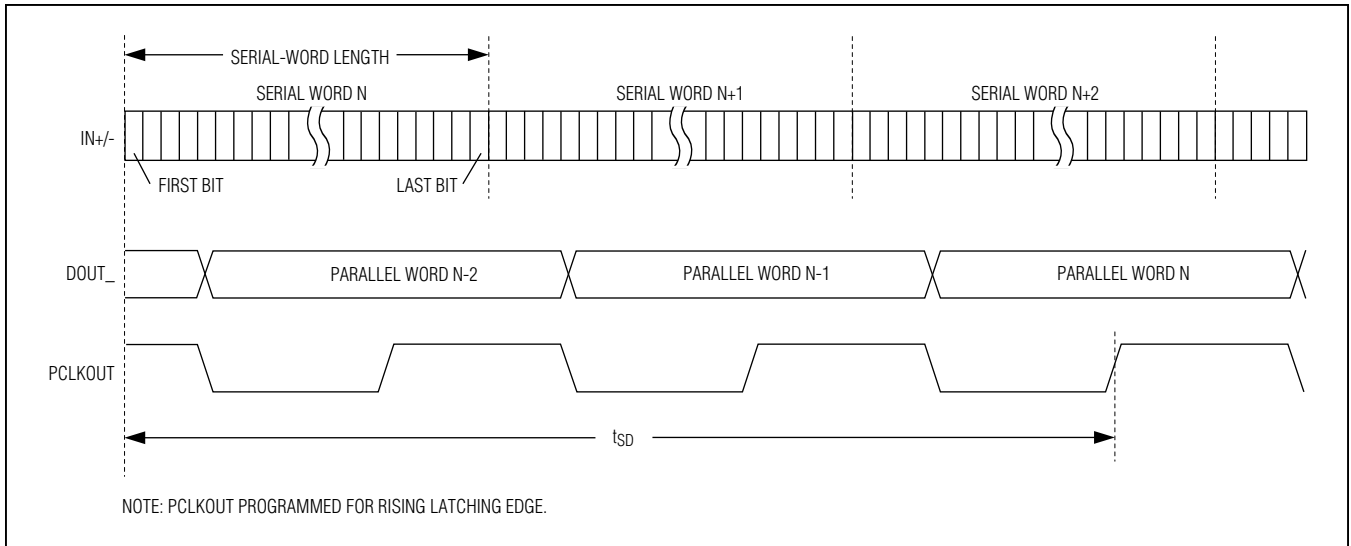

Figure 8. Deserializer Delay

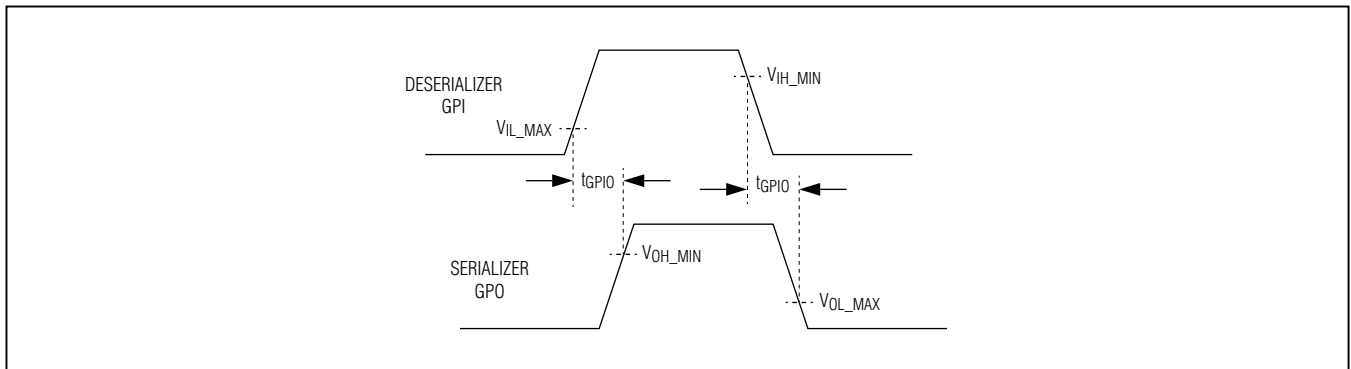

Figure 9. GPI-to-GPO Delay

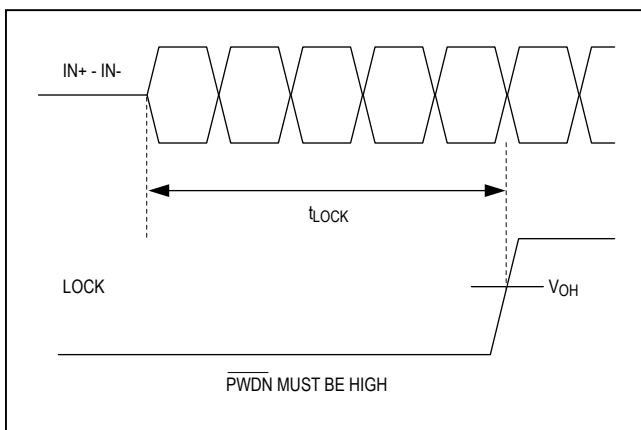

Figure 10. Lock Time

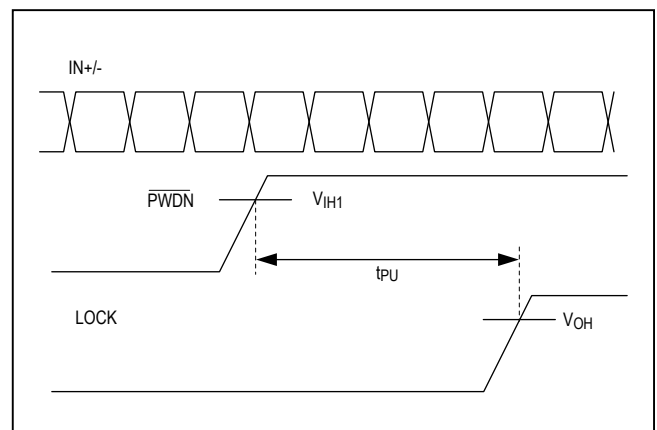

Figure 11. Power-Up Delay

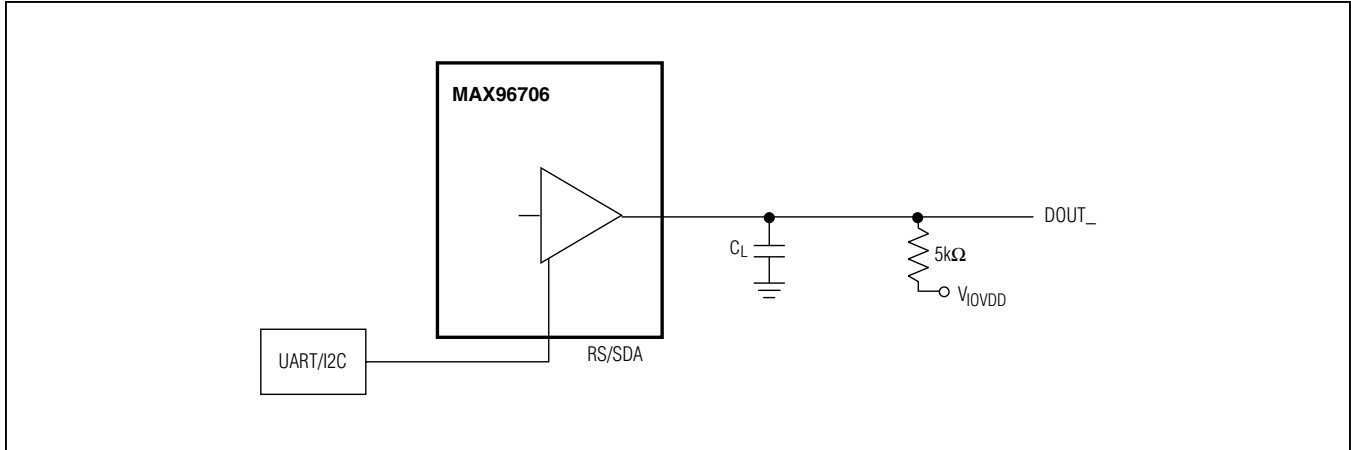

Figure 12. Active Output to High-Impedance Time, High Impedance to Active-Output Time Test Circuit

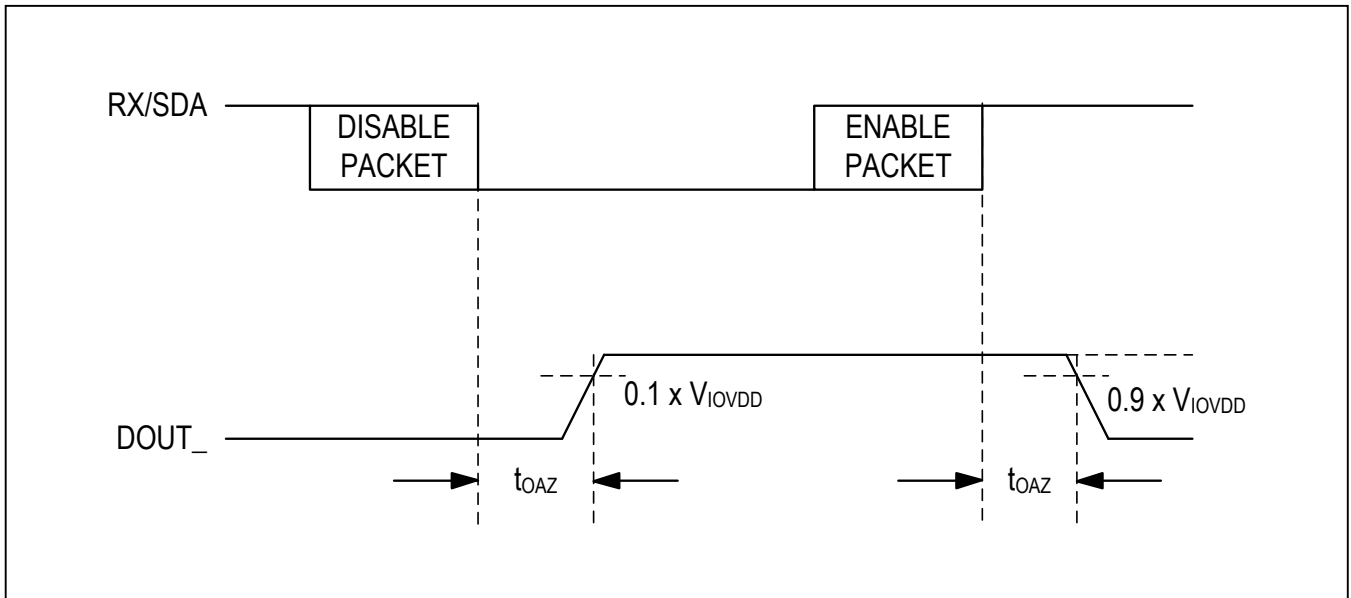

Figure 13. Active Output to High-Impedance Time, High Impedance to Active-Output Time

## Detailed Description

The MAX96706 deserializer is a compact device with features especially suited for automotive camera applications. The device operates at a variety of output widths and word rates up to a total serial-data rate up to 1.75Gbps. High-bandwidth mode offers a 116MHz parallel clock rate with 12 bits of video data + 2 bits of sync (HS/VS) data. An embedded 9.6kbps to 1Mbps control channel programs the serializer, deserializer, and any attached UART or I<sup>2</sup>C peripherals.

To promote safety applications, the device features CRC protection of video and control data. In addition, control-channel retransmission and high-immunity modes reduce the effects of bit errors corrupting communication. Automatic equalization, along with a PRBS tester and an embedded eye-width monitor, allow for in-system optimization of the link.

This device operates over the -40°C to +115°C automotive temperature range.

## Serial Link Signaling and Data Format

The serializer scrambles the input parallel data and combines this with the forward control data. The data is then encoded for transmission and output as a single bitstream at several times the input word rate (depending on bus width). The deserializer receives the serial data and recovers the clock signal. The data is then deserialized, decoded, and descrambled into parallel output data and forward control data.

## Operating Modes

The GMSL devices are configurable to operate in many modes, depending on the application. These modes allow for a more efficient use of serial bandwidth. Most of these settings are set during system design and are configured using the external configuration pins, or through register bits.

## Video/Configuration Link

In normal operation, the serializer runs in video-link mode (SEREN = 1) with video data and control data sent across the serial link. Set SEREN = 0 in the serializer to turn off serialization. The serializer powers up in video-link mode, and requires a valid PCLK for operation.

The configuration link is available to set up the serializer, deserializer, and peripherals when PCLK is not available. Set SEREN = 0 and CLINK = 1 in the serializer to enable the configuration link (SEREN = 1 forces the serializer into video-link mode). Once PCLK has been established, turn on the video link (SEREN = 1).

By default, video-link mode requires a valid PCLK for operation. Set AUTO\_CLINK bit = 1 (if supported), and SEREN = 1 in the serializer to automatically switch between the video link and configuration link whenever PCLK is not present.

## Single and Double Modes of Operation

Single-/double-mode operation configures the available 1.74Gbps bandwidth into a variety of widths and word rates. Single-mode operation is compatible with all GMSL devices, and serializes one parallel word for each serial word. Double mode serializes two half-width parallel words for each serial word, and results in a 2x increase in parallel word-rate range (compared to single mode). Set DBL = 0 for single-mode operation and DBL = 1 for double-mode operation.

## HS/VS Encoding

By default, GMSL assigns a video bit slot to HSYNC, VSYNC, and DE (if used). With HS/VS encoding, the device instead encodes special packets to sync signals to free up additional video bit slots. HS/VS encoding is on by default when the device is in high-bandwidth mode. (HIBW = 1). DE is encoded only when HIBW = 1 and DE\_EN = 1. Set HVEN = 1 to turn on HS/VS encoding when HIBW = 0 (DE, if enabled uses up a video bit). HS/VS encoding requires that HSYNC, VSYNC, and DE (if used) remain high during the active video, and low during the blanking period. Use HS/VS inversion when using reverse-polarity sync signals.

## Error Detection

The serial link's 8b/10b encoding/decoding, and 1-bit parity detect bit errors that occur on the serial link. An optional 6-bit CRC check is available at the expense of 6 video bits (when HIBW = 0). To activate 6-bit CRC mode, set PXL\_CRC = 1 in the remote-side device first, and then in the local-side device. When using 6-bit CRC mode, the available internal bus width is reduced by 6 bits in single-input mode (DBL = 0) and 3 bits in double-input mode (DBL = 1). Note that the input bus width may already have been reduced due to pin availability of the serializer or deserializer; thus, the reduction of bandwidth from CRC may not be visible (see [Table 3](#)).

An additional 32-bit video line CRC is available by setting LINE\_CRC\_EN = 1. When enabled, the serializer calculates the 32-bit CRC of the video line and sends this information during the blanking period. The deserializer compares the received CRC with the video line data. The deserializer's LINE\_CRC\_ERR bit latches when a CRC error is detected. LINE\_CRC\_ERR clears when read.

**Bus Widths**

The serial link has multiple bus-width settings that determine the parallel bus width and the resulting parallel word rate. The serial link operates to a maximum serial bit rate of 1.74Gbps. The BWS bit determines if each serial packet is 30 or 40 bits long, which translates to a maximum serial packet rate; thus, a maximum parallel word rate of 58MHz or 43.5MHz when BWS = 0 or 1, respectively. Decoding translates the 30- or 40-bit serial packets into 24, 27, or 32 parallel bits. One bit is used for parity, while a second is reserved for the control channel. An additional 6 bits is used during optional 6-bit CRC. In addition, double mode splits the remaining word size in

half if used. The remaining bits can be used for video bits minus any sync bits if HV encoding is not used.

**Note:** The following modes list the internal bus widths. The number of available input and output pins may limit the actual bus width available.

**24-Bit Mode (Figure 14)**

When BWS = 0 and HIBW = 0, the 30-bit serial packet corresponds with three 8b/10b symbols, representing 24 bits (24-bit mode). After parity and control channel, this leaves 16/22 bits of video data if CRC is/is not used (single mode), or 8/11 bits of video data if CRC is/is not used (double mode).

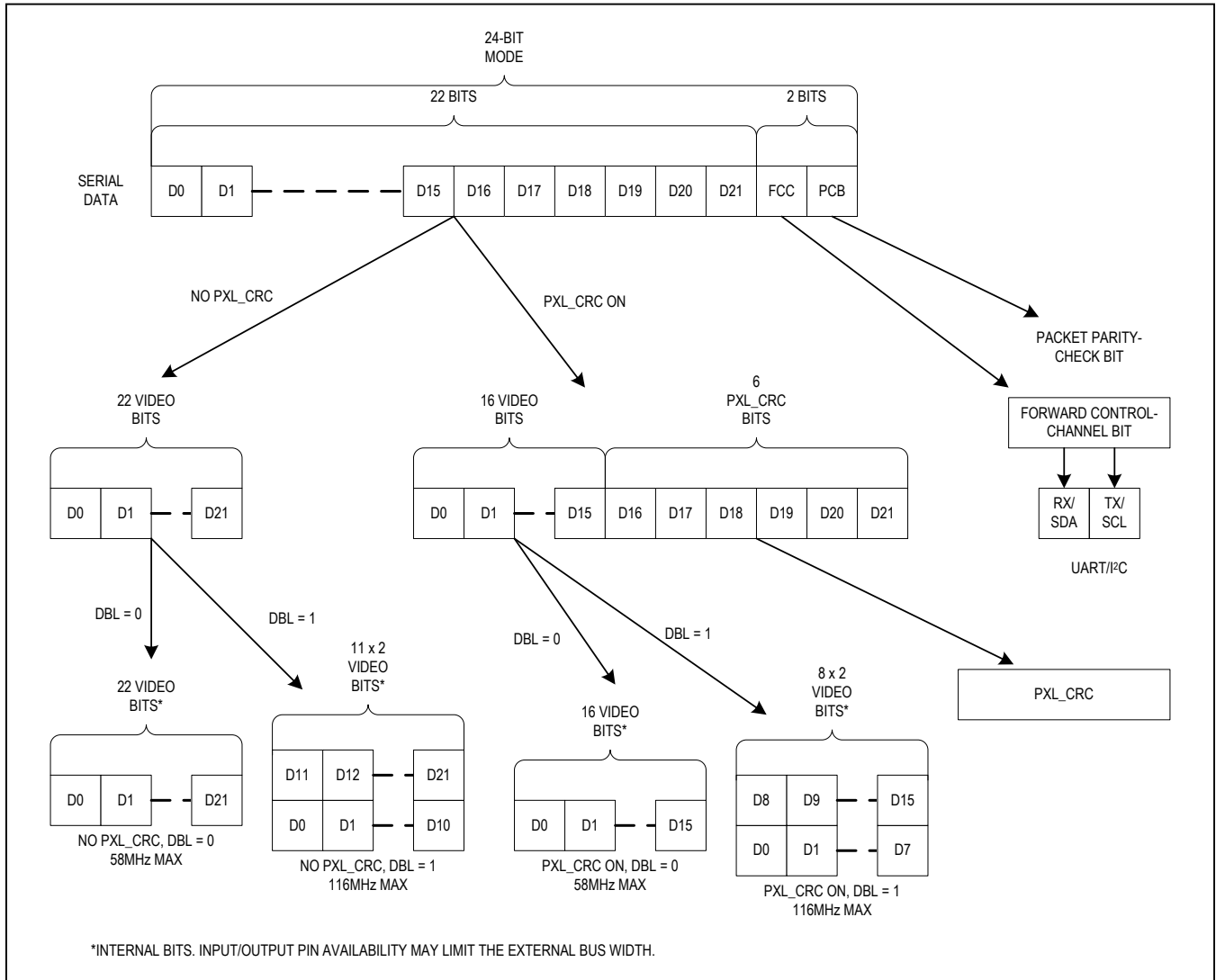

Figure 14. 24-Bit Mode Serial-Data Format

**27-Bit High-Bandwidth Mode (Figure 15)**

When BWS = 0 and HIBW = 1 (high-bandwidth mode) the 30-bit serial packet represents three 9b/10b symbols representing 27 bits. After parity and control channel, this leaves 19/25 bits of video data if CRC is/is not used (single mode), or 9/12 bits of video data if CRC is/is not used (double mode).

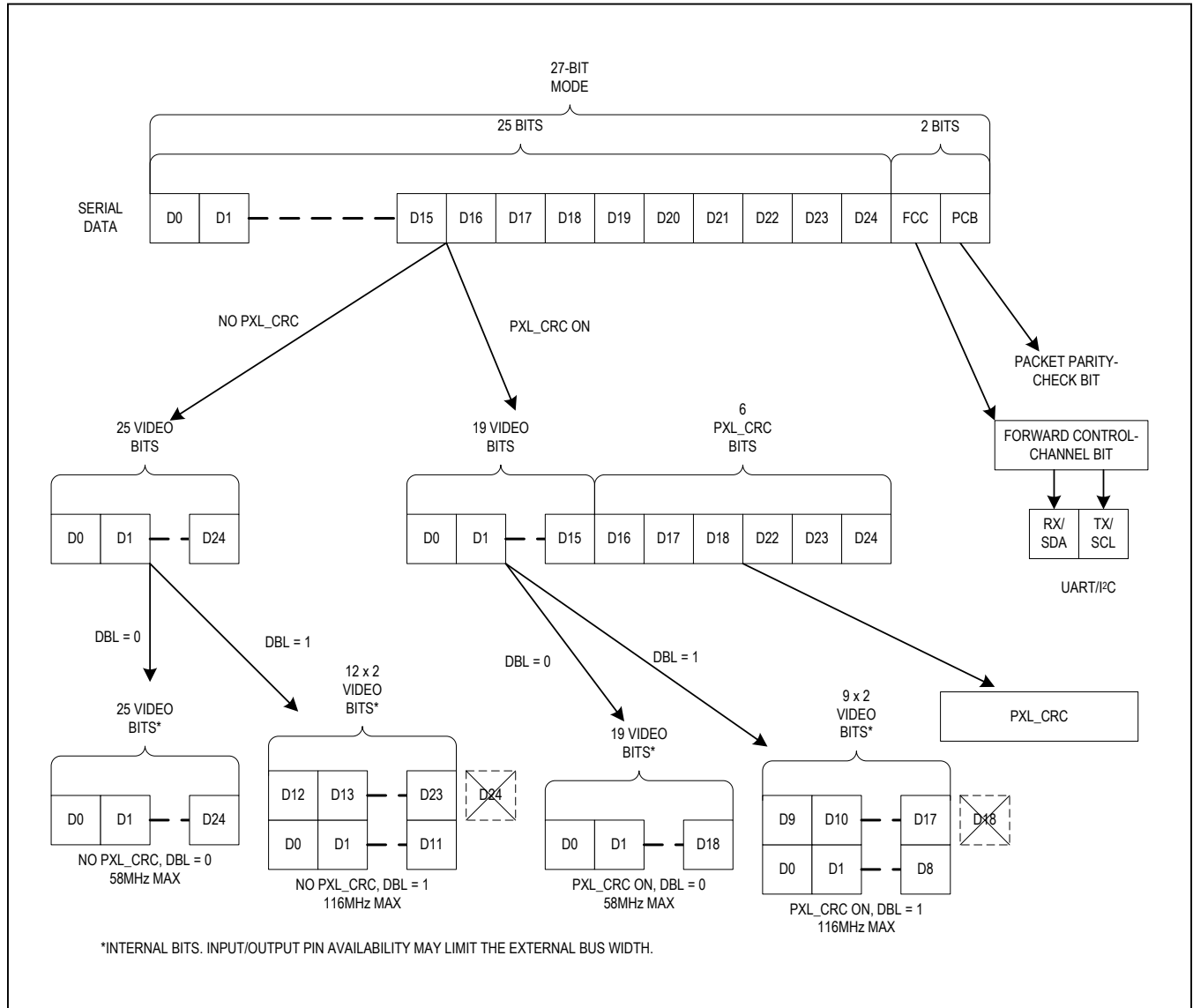

Figure 15. 27-Bit High-Bandwidth Mode Serial-Data Format

**32-Bit Mode (Figure 16)**

When BWS = 1 the 40-bit serial packet corresponds with four 8b/10b symbols, representing 32 bits (32-bit mode). After parity and control channel, this leaves 24/30 bits of video data if CRC is/is not used (single mode), or 12/15 bits of video data if CRC is/is not used (double mode).

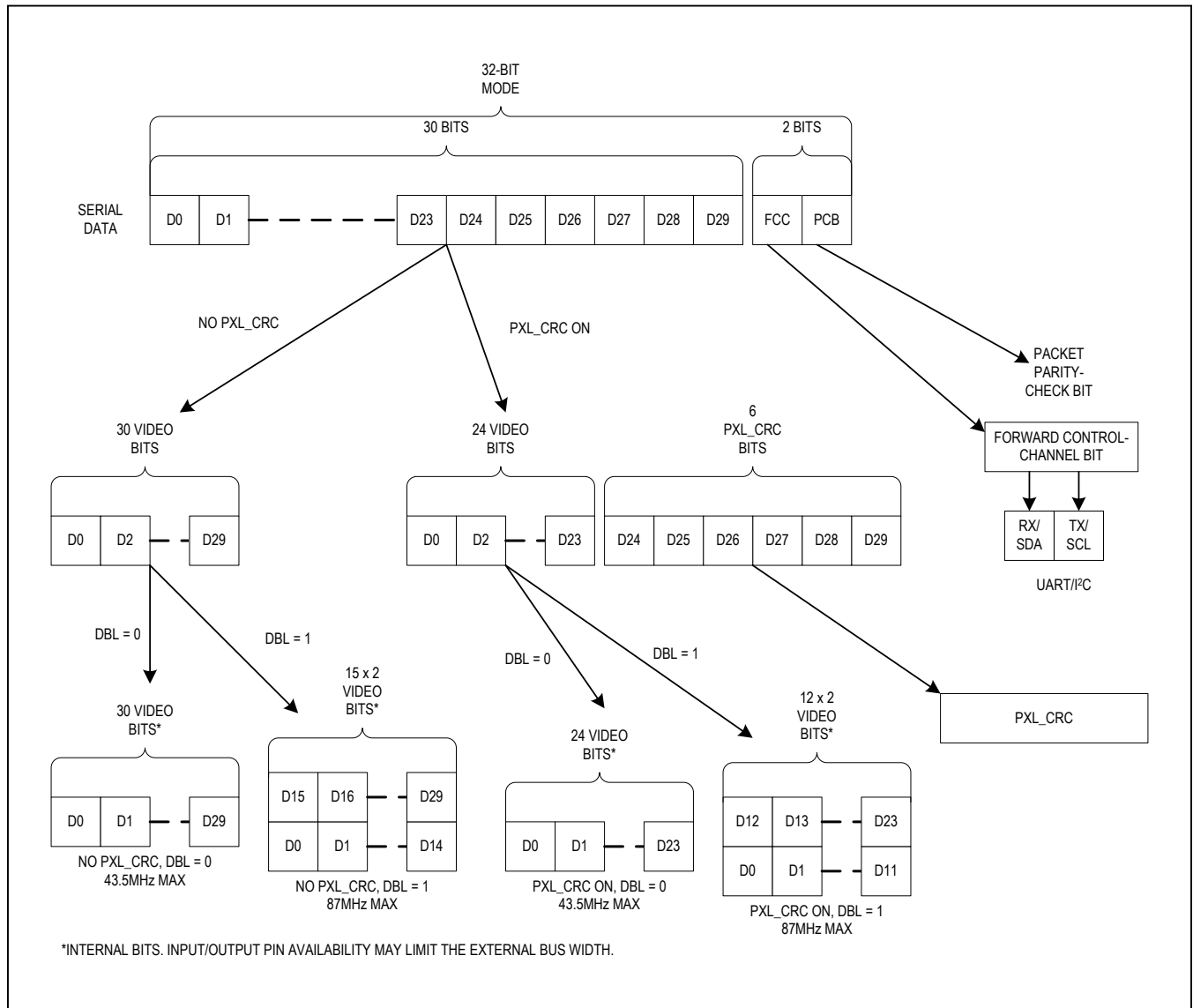

Figure 16. 32-Bit Mode Serial-Data Format

### Control Channel and Register Programming

The control channel sends I<sup>2</sup>C or UART information across the serial link for control of the serializer, deserializer, and any attached peripherals. The control channel is multiplexed onto the serial link and is available with or without the video channel.

#### Forward Control Channel

Control data sent from the serializer to the deserializer is sent on the forward control channel. The data is encoded as one of the serial bits in the forward high-speed link. After deserialization, the forward control-channel data is extracted from the serial link. The forward control-channel bandwidth exceeds the maximum external control data rate, and all data sent on the forward control channel appears on the remote side after transmission delay of a few bit times.

#### Reverse Control Channel

Control data sent from the deserializer to the serializer is sent on the reverse control channel. The data is encoded as a series of 1  $\mu$ s pulses, with a maximum raw data rate of 1Mbps. High-immunity mode is available to increase the robustness of the reverse control channel at a reduced raw bit rate of 500kbps (Table 1). In high-immunity mode, set HPFTUNE = 00 in the deserializer when the serial bit rate is larger than 1Gbps. Setting the REV\_FAST bit = 1 increases this rate back to 1Mbps. In I<sup>2</sup>C mode, when the input data rate (after encoding) exceeds the reverse data rate, the input clock is held through clock stretching to slow the external clock to match the internal bit rate.

#### UART Interface

The UART interface, compatible with all GMSL devices, sends commands from device to device through several UART packets. Set I2CSEL = 0 to set the device to use UART protocol.

#### I<sup>2</sup>C Interface

The serial link connects the serializer and deserializer I<sup>2</sup>C interfaces together through the control channel. When an I<sup>2</sup>C master sends a command to one side of the link (local side) the control channel forwards this information to and from the other side of the link (remote side), allowing a single microcontroller to configure the serializer, deserializer, and peripherals. The microcontroller can be located on the serializer side (display applications) and the deserializer side (camera applications). Dual- $\mu$ C operations are supported as long as a software-arbitration method is used. The serial link assumes that only one microcontroller is talking at any given time.

#### Remote-End Operation

When an I<sup>2</sup>C master initiates communication on the local slave device (the serializer/deserializer directly connected to the master), the remote-side device acts as a master device that sends data forwarded from the local-side device, and forwards any data received from peripherals attached to the remote-side device. This remote-side master device operates according to the timing settings in the I<sup>2</sup>C Master setting register. Set the master settings to match the timing settings used by the external microcontroller.

#### Clock-Stretch Timing

The I<sup>2</sup>C interface uses clock stretching to allow time for data to be forwarded across the serial link. The master microcontroller, along with any attached peripherals, must accept clock stretching of the GMSL devices.

#### Packet-Based I<sup>2</sup>C

A packet-based control channel is available for enhanced error handling of the control channel. This control-channel method handles simultaneous GPI/GPO and I<sup>2</sup>C transmission, along with error detection and retransmission.

**Table 1. Reverse Control-Channel Modes**

HIM PIN SETTING	REVFASST BIT	REVERSE CONTROL-CHANNEL MODE	MAX UART/I <sup>2</sup> C BIT RATE (kbps)
Low	X	Legacy reverse control-channel mode (compatible with all GMSL devices)	1000
High	0	High-immunity mode	500
	1	Fast high-immunity mode (requires HIBW = 0, serial-data rate > 1.25Gbps)	1000

X = Don't care.

### Packet Protocol Summary

The packet-based control channel uses a synchronous, symbol-based system to send data across the control channel. Data to be sent across the control channel is split into symbols and stored in a transmit queue and then sent across the link. If both GPI and I<sup>2</sup>C data need to be sent (e.g., when GPI transitions during an I<sup>2</sup>C transmission) the symbols from both commands are combined in the queue. If the transmit queue is empty, idle packets are sent across the link to maintain control-channel lock. Received I<sup>2</sup>C packets are output as determined by the microcontroller SCL rate (local device), or the programmed master bit rate (remote device). The device holds SCL low (clock stretch) until data has been received from the remote-side device.

### Control-Channel Error Detection and Packet Retransmission

When the packet-based control channel is used, all packets are checked for errors through CRC. Using 1, 5, or 8 bits, CRC detects 1, 3, or 4 random bit errors in a packet. The transmitter retransmits packets whenever an error is detected. The transmitter sets a flag if a number of retries exceeds eight. The receiver filters out packets with errors.

### GPO/GPI Control

GPO on the serializer follows GPI transitions on the deserializer. This GPO/GPI function can be used to transmit signals such as a frame sync in a surround-view camera system (see the [Providing a Frame Sync \(Camera Applications\)](#) section).

### Adaptive Line Equalizer

The deserializer includes an adaptive line equalizer to compensate for higher cable attenuation at higher frequencies. The cable equalizer has 12 levels of compensation to handle up to 30m coax and 15m STP cable lengths. At initial lock, the adaptive equalizer selects the optimum compensation level. The device can be programmed to re-adapt periodically, manually, or triggered from the eye-width monitor to compensate for any significant changes in the transmission environment.

### Eye-Width Monitor

The horizontal eye diagram opening is measured using the eye-width monitor. By default this measurement is done after link is established and also with 1 second intervals when link is running. Eye width below a programmed threshold flags the ERRB output pin. A very low eye width restarts equalizer adaptation.

### Spread-Spectrum Tracking

The deserializer can track a spread input clock, eliminating the need for multiple spread clocks.

### Cable-Type Configuration and Input MUX

The driver inputs are programmable for two kinds of cable: 100Ω twisted pair and 50Ω coax (contact the factory for devices compatible with 75Ω cables). In coax mode, connect IN0+ to OUT+ of the serializer. Connect IN1+ to OUT+ of the second serializer. Control-channel data is sent to the serializer selected with the GMSL\_IN\_SEL bit. Leave all unused IN\_ pins unconnected, or connect them to ground through 50Ω and a capacitor for increased power-supply rejection. If OUT- is not used, connect OUT- to V<sub>DD</sub> through a 50Ω resistor (Figure 17). When there are μCs at the serializer, and at each deserializer, only one μC can communicate at a time. Disable forward and reverse channel links according to the communicating deserializer connection to prevent contention in I<sup>2</sup>C-to-I<sup>2</sup>C mode.

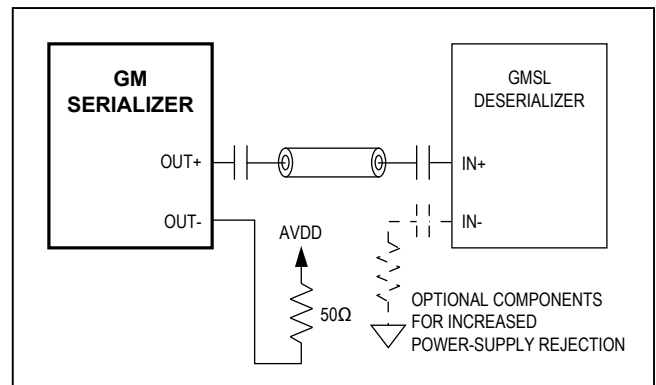

Figure 17. Coax Connection

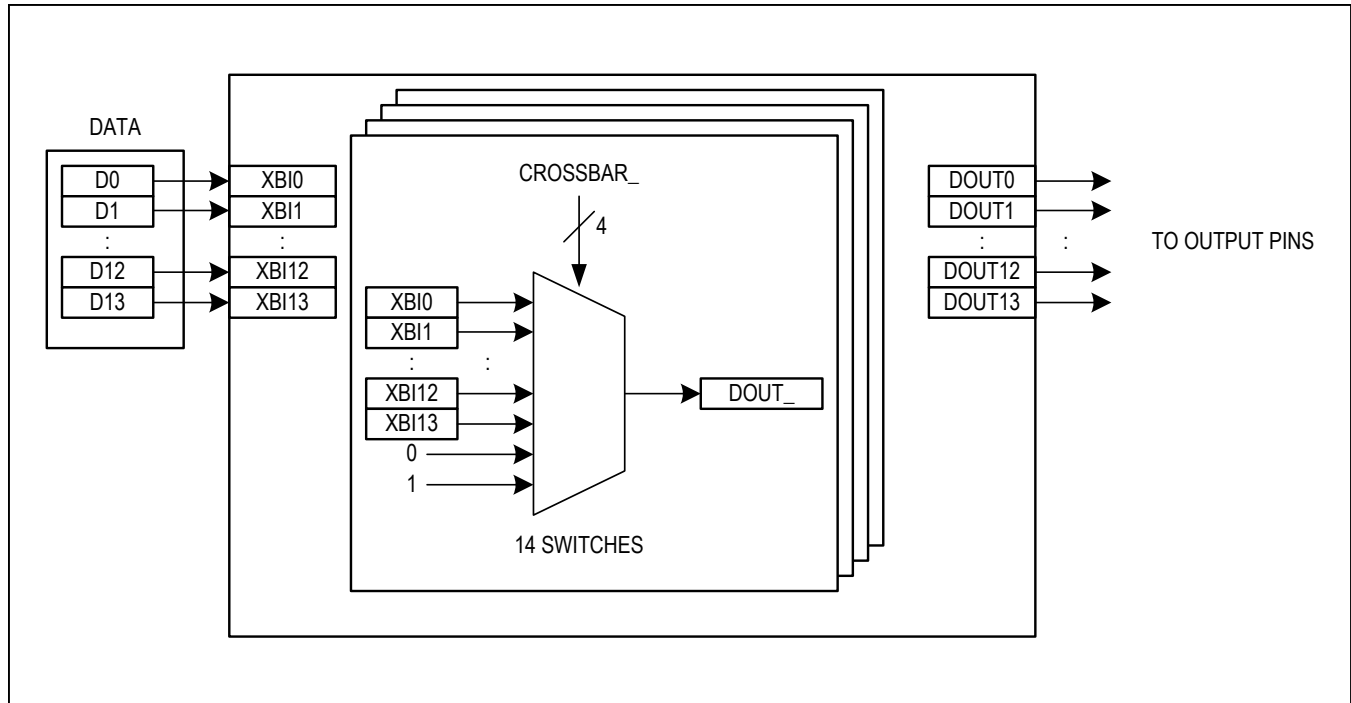

Figure 18. Crosspoint-Switch Dataflow

### Crosspoint Switch

The crosspoint switch routes data between the parallel input/output and the SerDes (Figure 18). The anything-to-anything routing assures the mapping between the video source and destination.

### Shutdown/Sleep Modes

Several sleep and shutdown modes are available when full operation is not needed.

#### Configuration Link

When the high-speed video link is not needed, or unavailable, a configuration link can be used in its place. In configuration-link mode, the parallel-digital input/output is disabled, the LOCK pin remains low, and the serial link internally generates its own clock, to allow full operation of the control channel (UART/I<sup>2</sup>C and GPIO).

#### Serialization Disable

When the serial link is not needed, such as when downstream devices are powered off, the user can disable serialization. In this mode, all forward communication is shut down. The user can reenble serialization either locally or through the reverse channel.

### Sleep Mode

To reduce power consumption further, the devices can be put into sleep mode. In this mode, all registers keep their programmed values, and all functions in the device are powered down except for the wake-up detectors on the local I<sup>2</sup>C/UART interface, and the serial link. Any activity seen by the wake-up detectors temporarily turns on the control-channel interface. During this time, a microcontroller can command the device to exit sleep mode. See the [Entering/Exiting Sleep Mode](#) section.

### Power-Down Mode

The lowest power-consumption mode is power-down mode. In this mode, all functions are powered down, and all register values are lost.

### Link-Startup Procedure

Table 2 lists the startup procedure for image-sensing applications. The control channel is available after the video link or the configuration link is established. If the deserializer powers up after the serializer, the control channel becomes unavailable until 2ms after power-up.

**Table 2. Link-Startup Procedure**

NO.	MC	SERIALIZER	DESERIALIZER
—	µC connected to deserializer.	Set all configuration inputs.	Set all configuration inputs.
1	Powers up. Wait t <sub>PJ</sub> .	Powers up and loads default settings. Establishes video link when valid PCLK available.	Powers up and loads default settings. Locks to video-link signal if available.
1a	(If no PCLK) Programs CLINKEN, SEREN, and/or AUTOCLINK bits. Wait 5ms after each command.	Establishes configuration link.	Locks to config link if available.
1b	(If not locked) Sets any additional configuration bits that are mismatched between serializer and deserializer (e.g BWS, CX/TP). Wait 5ms for lock after each command.	Configuration changed. Reestablishes configuration/video link if needed.	Configuration changed. Locks to configuration/video link.
2	Sets Register 0x07 configuration bits in the serializer (DBL, BWS, HIBW, PXL_CRC, etc.). Wait 2ms.	Configuration changed. Reestablishes config/video link if needed	Loss of lock may occur.
3	Sets Register 0x07 configuration bits in the deserializer (DBL, BWS, HIBW, PXL_CRC, etc.). Wait 5ms for lock to re-establish.	—	Configuration changed. Locks to configuration/video link.
4	Writes rest of serializer/deserializer configuration bits.	Configuration changed.	Configuration changed.
5	Writes camera/peripheral configuration bits.	Forwards commands from µC to serializer.	Forwards commands to camera/peripherals.
5a	If in configuration link: When PCLK is available, set SEREN = 1. Wait 5ms for lock.	Enables video link.	Locks to video link.

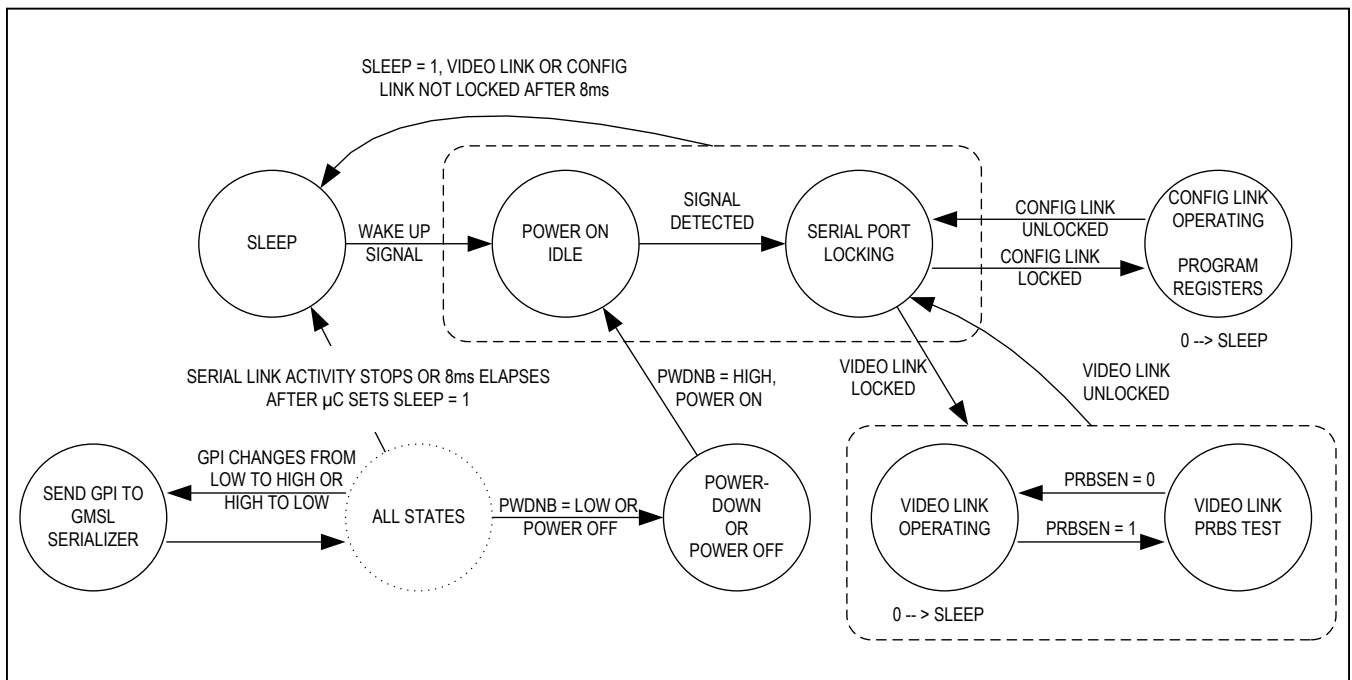

Figure 19. State Diagram

Register Map

OFFSET	NAME	MSB							LSB
0x00	seraddr[7:0]	SERADDR[6:0]							RSVD
0x01	desaddr[7:0]	DESADDR[6:0]							CFG-BLOCK
0x02	invpinh[7:0]	INVPINH[5:0]						SRNG[1:0]	
0x03	invpinl[7:0]	INVPINL[7:0]							
0x04	main config[7:0]	LOCKED	OUTENB	PRBSEN	SLEEP	INTTYPE[1:0]	REVCCEN	FWDCEN	
0x05	eqtune[7:0]	I2C-METHOD	DCS	HVTR_MODE	EN_EQ	EQTUNE[3:0]			
0x06	hvsrc[7:0]	HIGHIMM	MAX_RT_EN	I2C_RT_EN	GPI_COMP_EN	GPI_RT_EN	HV_SRC[2:0]		
0x07	config[7:0]	DBL	DRS	BWS	ES	HIBW	HVEN	CXTP	PXL_CRC
0x08	pktcc_en[7:0]	LFLT_EN_POS	LFLT_EN_NEG	GPI_EN	DISSTAG	ERR_RST	PKTCC_EN	CC_CRC_LENGTH[1:0]	
0x09	i2csrc A[7:0]	I2C_SRC_A[6:0]							RSVD
0x0A	i2cdst A[7:0]	I2C_DST_A[6:0]							RSVD
0x0B	i2csrc B[7:0]	I2C_SRC_B[6:0]							RSVD
0x0C	i2cdst B[7:0]	I2C_DST_B[6:0]							RSVD
0x0D	i2cconfig[7:0]	I2C_LOC_ACK	I2C_SLV_SH[1:0]		I2C_MST_BT[2:0]			I2C_SLV_TO[1:0]	
0x0E	det_thr[7:0]	DET_THR[7:0]							
0x0F	filt_track[7:0]	GMSL_IN_SEL	EN_DE_FILTER	EN_HS_FILTER	EN_VS_FILTER	DE_EN	HTRACK	VTRACK	PRBS_TYPE
0x10	rceg[7:0]	RCEG_TYPE[1:0]		RCEG_BOUND	RCEG_ERR_NUM[3:0]				RCEG_EN
0x11	rceg2[7:0]	RCEG_ERR_RATE[3:0]				RCEG_LO_BST_PRB[1:0]		RCEG_LO_BST_LEN[1:0]	
0x12	line_crc[7:0]	UNDER_BST_DET_EN	CC_CRC_ERR_EN	LINE_CRC_LOC[1:0]		LINE_CRC_EN	DIS_WAKE	MAX_RT_ERR_EN	RCEG_ERR_PER_EN
0x13	ewm[7:0]	EWM_EN	EWM_PER_MODE	EWM_MAN_TRG_REQ	EWM_MIN_THR[4:0]				
0x14	aeq[7:0]	AEQ_EN	AEQ_PER_MODE	AEQ_MAN_TRG_REQ	EWM_PER_THR[4:0]				
0x15	det_err[7:0]	DET_ERR[7:0]							
0x16	prbs_err[7:0]	PRBS_ERR[7:0]							
0x17	lf[7:0]	RSVD	MAX_RT_ERR	PRBS_OK	GPI_IN	LF_NEG[1:0]		LF_POS[1:0]	
0x18	rsvd_18[7:0]	RSVD[7:0]							
0x19	cc_crc_errcnt[7:0]	CC_CRC_ERRCNT[7:0]							
0x1A	rceg_err_cnt[7:0]	RCEG_ERR_CNT[7:0]							

OFFSET	NAME	MSB							LSB
0x1B	i2csel[7:0]	RSVD	RSVD	RSVD	RSVD	I2CSEL	LINE_CRC_ERR	RSVD	RSVD
0x1C	ewm_eye_width[7:0]	RSVD	RSVD	EOM_EYE_WIDTH[5:0]					
0x1D	aeq_bst[7:0]	RSVD	RSVD	RSVD	UNDER-BOOST_DET	AEQ_BST[3:0]			
0x1E	id[7:0]	ID[7:0]							
0x1F	revision[7:0]	RSVD	RSVD	RSVD	HDCPCAP	REVISION[3:0]			
0x20	crcvalue 0[7:0]	CRCVALUE_0_[7:0]							
0x21	crcvalue 1[7:0]	CRCVALUE_1_[7:0]							
0x22	crcvalue 2[7:0]	CRCVALUE_2_[7:0]							
0x23	crcvalue 3[7:0]	CRCVALUE_3_[7:0]							

0x65	crossbar 0[7:0]	CROSSBAR_N_0[3:0]				CROSSBAR_N+1_0[3:0]				
0x66	crossbar 2[7:0]	CROSSBAR_N_2[3:0]				CROSSBAR_N+1_2[3:0]				
0x67	crossbar 4[7:0]	CROSSBAR_N_4[3:0]				CROSSBAR_N+1_4[3:0]				
0x68	crossbar 6[7:0]	CROSSBAR_N_6[3:0]				CROSSBAR_N+1_6[3:0]				
0x69	crossbar 8[7:0]	CROSSBAR_N_8[3:0]				CROSSBAR_N+1_8[3:0]				
0x6A	crossbar 10[7:0]	CROSSBAR_N_10[3:0]				CROSSBAR_N+1_10[3:0]				
0x6B	crossbar 12[7:0]	CROSSBAR_N_12[3:0]				CROSSBAR_N+1_12[3:0]				
0x96	rsvd_96[7:0]	RSVD[1:0]		RSVD[1:0]		RSVD	RSVD	RSVD	RSVD	
0x97	rev_fast[7:0]	REV_FAST	RSVD	RSVD[5:0]						
0x98	rsvd_98[7:0]	RSVD	RSVD	RSVD[5:0]						
0x99	rsvd_99[7:0]	RSVD	RSVD	RSVD	RSVD	RSVD	RSVD	RSVD	RSVD	
0x9A	rsvd_9a[7:0]	RSVD	RSVD	RSVD[1:0]		RSVD[2:0]			RSVD	
0x9B	rsvd_9b[7:0]	RSVD	RSVD[1:0]		RSVD[2:0]			RSVD[1:0]		
0x9C	rsvd_9c[7:0]	RSVD	RSVD[1:0]		RSVD	RSVD[3:0]				
0x9D	rsvd_9d[7:0]	RSVD	RSVD	RSVD	RSVD	SOFT_PD	RSVD	RSVD	RSVD	
0x9E	rsvd_9e[7:0]	RSVD	RSVD[1:0]		RSVD[2:0]			RSVD	RSVD	
0x9F	rsvd_9f[7:0]	RSVD	RSVD	RSVD	RSVD	RSVD	HPFTUNE[1:0]		RSVD	
0xA0	rsvd_a0[7:0]	RSVD	RSVD	RSVD[1:0]		RSVD[3:0]				
0xA1	rsvd_a1[7:0]	RSVD[2:0]			RSVD[4:0]					
0xA2	rsvd_a2[7:0]	RSVD[7:0]								
0xA3	rsvd_a3[7:0]	RSVD[3:0]				RSVD[3:0]				
0xA4	rsvd_a4[7:0]	RSVD[2:0]			RSVD	RSVD	RSVD	RSVD[1:0]		
0xA5	rsvd_a5[7:0]	RSVD[3:0]				RSVD[1:0]		RSVD[1:0]		
0xA6	rsvd_a6[7:0]	RSVD	RSVD	RSVD	RSVD	RSVD[1:0]		RSVD[1:0]		

OFFSET	NAME	MSB							LSB
0xC9	rsvd_c9[7:0]	RSVD[7:0]							
0xCA	rsvd_ca[7:0]	RSVD	RSVD	RSVD	RSVD[1:0]		RSVD	RSVD	RSVD
0xCB	cc_locked[7:0]	RSVD	RSVD	RSVD	RSVD	CC_WBLOCK	REM_CCLOCK	CC_WBLOCK_LOST	RSVD
0xCC	rsvd_cc[7:0]	RSVD	RSVD[6:0]						
0xCD	rsvd_cd[7:0]	RSVD	RSVD[6:0]						

0xFD	rsvd_fd[7:0]	RSVD[7:0]							
0xFE	rsvd_fe[7:0]	RSVD[3:0]				RSVD[3:0]			
0xFF	rsvd_ff[7:0]	RSVD	RSVD	RSVD	RSVD	RSVD[3:0]			

**seraddr (0x00)**

BIT	7	6	5	4	3	2	1	0
<b>Field</b>	SERADDR[6:0]							RSVD
<b>Reset</b>	1000000b							0b
<b>Access Type</b>	Write, Read							Write, Read

BITFIELD	BITS	DESCRIPTION	DECODE
SERADDR	7:1	<b>Serializer Address:</b> Serializer device address	0000000: I <sup>2</sup> C write/read address is 0x00, 0x01 0000001: I <sup>2</sup> C write/read address is 0x02, 0x03 XXXXXXX: I <sup>2</sup> C write/read address is XXXXXXX0, XXXXXXX1 1111111: I <sup>2</sup> C write/read address is 0xFE, 0xFF
RSVD	0	<b>Reserved:</b> Do not change from default value	0: Reserved

**desaddr (0x01)**

BIT	7	6	5	4	3	2	1	0
<b>Field</b>	DESADDR[6:0]							CFGBLOCK
<b>Reset</b>	XXXXXXXb							0b
<b>Access Type</b>	Write, Read							Write, Read

BITFIELD	BITS	DESCRIPTION	DECODE
DESADDR	7:1	<b>Deserializer Address:</b> Deserializer device address (initial value depends on ADD3, ADD2, ADD1, and ADD0 pin settings latched at power-up)	0000000: I <sup>2</sup> C write/read address is 0x00, 0x01 0000001: I <sup>2</sup> C write/read address is 0x02, 0x03 XXXXXXX: I <sup>2</sup> C write/read address is XXXXXXX0, XXXXXXX1 1111111: I <sup>2</sup> C write/read address is 0xFE, 0xFF
CFGBLOCK	0	<b>Configuration Block.</b> When 1, make all registers read only	0: Set all write/read registers as writable 1: Set all registers as read only

**invpinh (0x02)**

BIT	7	6	5	4	3	2	1	0
<b>Field</b>	INVPINH[5:0]						SRNG[1:0]	
<b>Reset</b>	000000b						11b	
<b>Access Type</b>	Write, Read						Write, Read	

BITFIELD	BITS	DESCRIPTION	DECODE
INVPINH	7:2	<b>Invert Output Pins High:</b> Invert output pins D8–D13	XXXXX0: Do not invert D8 XXXXX1: Invert D8 XXXX0X: Do not invert D9 XXXX1X: Invert D9 XXX0XX: Invert D10 XXX1XX: Do not invert D10 XX0XXX: Do not invert D11 XX1XXX: Invert D11 X0XXXX: Do not invert D12 X1XXXX: Invert D12 0XXXXX: Do not invert D13 1XXXXX: Invert D13
SRNG	1:0	<b>Serial Data-Rate Range</b>	00: 0.5 to 1Gbps 01: 1 to 1.74Gbps 1X: Autodetect serial range

invpinl (0x03)

BIT	7	6	5	4	3	2	1	0
Field	INVPINL[7:0]							
Reset	0000000b							
Access Type	Write, Read							

BITFIELD	BITS	DESCRIPTION	DECODE
INVPINL	7:0	<b>Invert Output Pins Low:</b> Invert output pins D0–D7	XXXXXX0: Do not invert D0 XXXXXX1: Invert D0 XXXXX0X: Do not invert D1 XXXXX1X: Invert D1 XXXX0XX: Do not invert D2 XXXX1XX: Invert D2 XXXX0XX: Do not invert D3 XXXX1XX: Invert D3 XXX0XXX: Do not invert D4 XXX1XXX: Invert D4 XX0XXXX: Do not invert D5 XX1XXXX: Invert D5 X0XXXXX: Do not invert D6 X1XXXXX: Invert D6 0XXXXXX: Do not invert D7 1XXXXXX: Invert D7

main config (0x04)

BIT	7	6	5	4	3	2	1	0
Field	LOCKED	OUTENB	PRBSEN	SLEEP	INTTYPE[1:0]		REVCCEN	FWDCEN
Reset	Xb	0b	0b	0b	01b		1b	1b
Access Type	Read Only	Write, Read	Write, Read	Write, Read	Write, Read		Write, Read	Write, Read

BITFIELD	BITS	DESCRIPTION	DECODE
LOCKED	7	<b>LOCK Output:</b> LOCK output pin level	0: Video link not locked 1: Video link locked
OUTENB	6	<b>Outputs Enable Bar:</b> Disable outputs	0: Enable DOUT_ outputs 1: Disable DOUT_ outputs
PRBSEN	5	<b>PRBS Test Enable</b>	0: Set device for normal operation 1: Enable PRBS test
SLEEP	4	<b>Sleep Mode:</b> Activate sleep mode	0: Set device for normal operation 1: Put device into sleep mode
INTTYPE	3:2	<b>Interface Type:</b> Local control-channel interface when I2CSEL = 0	00: UART-to-I2C conversion 01: UART 1X: Disable local control channel
REVCCEN	1	<b>Reverse Control-Channel Enable:</b> Enable reverse control channel from deserializer	0: Disable reverse control-channel receiver 1: Enable reverser control-channel receiver
FWDCEN	0	<b>Forward Control-Channel Enable:</b> Enable forward control channel to deserializer	0: Disable forward control-channel transmitter 1: Enable forward control-channel transmitter

**eqtune (0x05)**

BIT	7	6	5	4	3	2	1	0
<b>Field</b>	I2C-METHOD	DCS	HVTR_MODE	EN_EQ	EQTUNE[3:0]			
<b>Reset</b>	0b	0b	1b	1b	1001b			
<b>Access Type</b>	Write, Read	Write, Read	Write, Read	Write, Read	Write, Read			

BITFIELD	BITS	DESCRIPTION	DECODE
I2CMETHOD	7	<b>I2C Method:</b> Skip register address when converting UART to I2C	0: Send the register address during UART-to-I2C conversion 1: Do not send the register address during UART-to-I2C conversion
DCS	6	<b>Driver Current Selection:</b> Driver current selection for CMOS outputs	0: Set device for normal operation 1: Increase CMOS driver current
HVTR_MODE	5	<b>HV Tracking Mode:</b> HV tracking allows continuous HSYNC format	0: Use partial periodic HV tracking 1: Use partial and full periodic HV tracking
EN_EQ	4	<b>Enable Equalizer:</b> Enable equalizer for manual and adaptive modes	0: Disable equalization 1: Enable equalization
EQTUNE	3:0	<b>Equalizer Tune:</b> Equalizer boost level at 750MHz (effective when Adaptive EQ is turned off)	0000: 1.6dB manual EQ setting 0001: 2.1dB manual EQ setting 0010: 2.8dB manual EQ setting 0011: 3.5dB manual EQ setting 0100: 4.3dB manual EQ setting 0101: 5.2dB manual EQ setting 0110: 6.3dB manual EQ setting 0111: 7.3dB manual EQ setting 1000: 8.5dB manual EQ setting 1001: 9.7dB manual EQ setting 1010: 11dB manual EQ setting 1011: 12.2dB manual EQ setting 11XX: <b>Do Not Use</b>

hvsrc (0x06)

BIT	7	6	5	4	3	2	1	0
Field	HIGHIMM	MAX_RT_EN	I2C_RT_EN	GPI_COMP_EN	GPI_RT_EN	HV_SRC[2:0]		
Reset	Xb	1b	1b	0b	1b	111b		
Access Type	Write, Read	Write, Read	Write, Read	Write, Read	Write, Read	Write, Read		

BITS	DESCRIPTION	DECODE
HIGHIMM	<b>High-Immunity Mode:</b> Default value depends on the state of the HIM input	0: Use legacy reverse-channel mode 1: Use high-immunity mode
6	<b>Maximum Retransmission Limit Enable</b>	0: Disable maximum retransmission limit 1: Enable maximum retransmission limit
5	<b>I2C Retransmission Enable</b>	0: Disable I2C retransmission 1: Enable I2C retransmission
4	<b>GPI Compensation Enable:</b> GPI skew compensation enable	0: Disable GPI skew compensation 1: Enable GPI skew compensation
3	<b>GPI Retransmission Enable</b>	0: Disable GPI retransmission 1: Enable GPI retransmission
2:0	<b>HS/VS Source Selection:</b> HS/VS bit selection	000: Use D18/D19 for HS/VS (use this setting when the serializer is a 3.125Gbps device or if HIBW mode is used; otherwise, this setting is for use with the MAX9273 when DBL = 0 or HVEN = 1) 001: Use D14/D15 for HS/VS (for use with the MAX9271/MAX96705 when DBL = 0 or HVEN = 1) 010: Use D12/D13 for HS/VS (for use with the MAX96707 when DBL = 0 or HVEN = 1) 011: Use D0/D1 for HS/VS (for use with the MAX9271/MAX9273/MAX96705/MAX96707 when DBL = 1 and HVEN = 0) 10X: <b>Do Not Use</b> 110: Automatically determine the source of HSYNC/VSYNC (for use with the MAX96707) 111: Automatically determine the source of HSYNC/VSYNC (for use with the MAX96705)

config (0x07)

BIT	7	6	5	4	3	2	1	0
Field	DBL	DRS	BWS	ES	HIBW	HVEN	CXTP	PXL_CRC
Reset	0b	0b	0b	0b	0b	0b	Xb	0b
Access Type	Write, Read	Write, Read	Write, Read	Write, Read	Write, Read	Write, Read	Write, Read	Write, Read

BITFIELD	BITS	DESCRIPTION	DECODE
DBL	7	<b>Double-Output Mode</b>	0: Use single-rate output 1: Use double-rate output (2x word rate at 1/2x width)
DRS	6	<b>Data-Rate Select</b>	0: Use normal data-rate output 1: Use 1/2 rate data output (for use with low data rates)
BWS	5	<b>Bus-Width Select</b>	0: Set bus width for 22-/24-bit bus, 24-/27-bit mode (depending on HIBW setting) 1: Set bus width for 30-bit bus (32-bit mode)
ES	4	<b>Edge Select</b>	0: Set output data valid on rising edge of PCLKOUT 1: Set output data valid on falling edge of PCLKOUT
HIBW	3	<b>High-Bandwidth Mode</b>	0: Disable high-bandwidth mode 1: Enable high-bandwidth mode (when BWS = 0)
HVEN	2	<b>HS/VS Encoding Enable</b>	0: Disable HS/VS encoding 1: Enable HS/VS encoding
CXTP	1	<b>Coax/TP Select</b>	0: Use differential-output mode (for use with twisted-pair cable) 1: Use single-ended output mode (for use with coax cable)
PXL_CRC	0	<b>Pixel CRC Enable:</b> Pixel error-detection type (this is controllable by pin when LCCEN = 0)	0: Use 1-bit parity (compatible with all devices) 1: Use 6-bit CRC

pktcc\_en (0x08)

BIT	7	6	5	4	3	2	1	0
Field	LFLT_EN_POS	LFLT_EN_NEG	GPI_EN	DISSTAG	ERR_RST	PKTCC_EN	CC_CRC_LENGTH[1:0]	
Reset	1b	Xb	1b	0b	0b	0b	01b	
Access Type	Write, Read	Write, Read	Write, Read	Write, Read	Write, Read	Write, Read	Write, Read	

BITFIELD	BITS	DESCRIPTION	DECODE
LFLT_EN_POS	7	<b>Line-Fault Detector Enable Positive Line:</b> Enable line-fault detector LMN0	0: Disable line-fault detector LMN0 1: Enable line-fault detector LMN0
LFLT_EN_NEG	6	<b>Line-Fault Detector Enable Negative Line:</b> Enable line-fault detector LMN1; disabled by default in coax mode and enabled by default in twisted-pair mode	0: Disable line-fault detector LMN1 1: Enable line-fault detector LMN1
GPI_EN	5	<b>GPI-to-GPO Enable:</b> Enable GPI-to-GPO signal transmission to serializer	0: Disable GPI-to-GPO transmission 1: Enable GPI-to-GPO transmission
DISSTAG	4	<b>Disable Staggering:</b> Disable staggering of outputs	0: Enable staggering of DOUT_outputs 1: Disable staggering of DOUT_outputs
ERR_RST	3	<b>Error Reset:</b> When set to 1, automatically reset DET_ERR 1µs after ERROR pin is asserted	0: Disable automatic reset of DETERR_register 1: Enable automatic reset of DETERR_register
PKTCC_EN	2	<b>Packet-Based Control-Channel Mode Enable</b>	0: Disable packet-based control-channel mode 1: Enable packet-based control-channel mode
CC_CRC_LENGTH	1:0	<b>Control-Channel CRC Length</b>	00: 1-bit CRC 01: 5-bit CRC 10: 8-bit CRC 11: <b>Do Not Use</b>

i2csrc (0x09, 0x0B)

BIT	7	6	5	4	3	2	1	0
Field	I2C_SRC[6:0]							RSVD
Reset	0b							0b
Access Type	Write, Read							Write, Read

BITFIELD	BITS	DESCRIPTION	DECODE
I2C_SRC	7:1	<b>I2C Address Translator Source:</b> I2C address translator source A	0000000: I2C write/read address is 0x00, 0x01 0000001: I2C write/read address is 0x02, 0x03 XXXXXXX: I2C write/read address is XXXXXXX0, XXXXXXX1 1111111: I2C write/read address is 0xFE, 0xFF
RSVD	0	<b>Reserved:</b> Do not change from default value	0: Reserved

**i2cdst (0x0A, 0x0C)**

BIT	7	6	5	4	3	2	1	0
Field	I2C_DST[6:0]							RSVD
Reset	0b							0b
Access Type	Write, Read							Write, Read

BITFIELD	BITS	DESCRIPTION	DECODE
I2C_DST	7:1	I2C address translator destination: I2C address translator destination A	0000000: I2C write/read address is 0x00, 0x01 0000001: I2C write/read address is 0x02, 0x03 XXXXXXXX: I2C write/read address is XXXXXXXX0, XXXXXXXX1 1111111: I2C write/read address is 0xFE, 0xFF
RSVD	0	<b>Reserved:</b> Do not change from default value	0: Reserved

**i2config (0x0D)**

BIT	7	6	5	4	3	2	1	0
Field	I2C_LOC_ACK	I2C_SLV_SH[1:0]		I2C_MST_BT[2:0]		I2C_SLV_TO[1:0]		
Reset	0b	01b		101b		10b		
Access Type	Write, Read	Write, Read		Write, Read		Write, Read		

BITFIELD	BITS	DESCRIPTION	DECODE
I2C_LOC_ACK	7	<b>I2C-to-I2C Slave Local Acknowledge:</b> When forward channel is not available	0: Disable local acknowledge when forward channel is not available 1: Enable local acknowledge when forward channel is not available
I2C_SLV_SH	6:5	<b>I2C-to-I2C Slave Setup and Hold Time Setting:</b> Setup, hold (typ)	00: (352, 117)ns 01: (469, 234)ns 10: (938, 352)ns 11: (1406, 469)ns
I2C_MST_BT	4:2	<b>I2C-to-I2C Master Bit Rate Setting:</b> Min, typ, max.	000: (6.61, 8.47, 9.92)kbps bit rate 001: (22.1, 28.3, 33.2)kbps bit rate 010: (66.1, 84.7, 99.2)kbps bit rate 011: (82, 105, 123)kbps bit rate 100: (136, 173, 203)kbps bit rate 101: (265, 339, 397)kbps bit rate 110: (417, 533, 625)kbps bit rate 111: (654, 837, 980)kbps bit rate
I2C_SLV_TO	1:0	<b>I2C-to-I2C Slave Remote-Side Timeout Setting:</b> Typ	00: 64µs timeout 01: 256µs timeout 10: 1024µs timeout 11: I2C timeout disabled

**det\_thr (0x0E)**

BIT	7	6	5	4	3	2	1	0
Field	DET_THR[7:0]							
Reset	0000000b							
Access Type	Write, Read							

BITFIELD	BITS	DESCRIPTION	DECODE
DET_THR	7:0	<b>Detected Errors Threshold:</b> Threshold for detected errors	00000000: Value is 0 00000001: Value is 1, XXXXXXXX 11111111: Value is 255

**filt\_track (0x0F)**

BIT	7	6	5	4	3	2	1	0
Field	GMSL_IN_SEL	EN_DE_FILT	EN_HS_FILT	EN_VS_FILT	DE_EN	HTRACK	VTRACK	PRBS_TYPE
Reset	0b	0b	0b	0b	0b	0b	0b	1b
Access Type	Write, Read	Write, Read	Write, Read	Write, Read	Write, Read	Write, Read	Write, Read	Write, Read

BITFIELD	BITS	DESCRIPTION	DECODE
GMSL_IN_SEL	7	<b>Select GMSL Input</b>	0: Select IN0+, IN0- 1: Select IN1+, IN1-
EN_DE_FILT	6	<b>Enable DE Glitch Filtering:</b> Enable glitch filtering on DOUT11	0: Disable glitch filtering on DOUT11 1: Enable glitch filtering on DOUT11
EN_HS_FILT	5	<b>Enable HS Glitch Filtering:</b> Enable glitch filtering on DOUT12	0: Disable glitch filtering on DOUT12 1: Enable glitch filtering on DOUT12
EN_VS_FILT	4	<b>Enable VS Glitch Filtering:</b> Enable glitch filtering on DOUT13	0: Disable glitch filtering on DOUT13 1: Enable glitch filtering on DOUT13
DE_EN	3	<b>DE Processing Enable:</b> Enable processing separate HS and DE signals	0: Disable processing HS and DE signals 1: Enable processing HS and DE signals
HTRACK	2	<b>HS Tracking Enable</b>	0: Disable HS tracking 1: Enable HS tracking
VTRACK	1	<b>VS Tracking Enable</b>	0: Disable VS tracking 1: Enable VS tracking
PRBS_TYPE	0	<b>PRBS Type Select:</b> PRBS type select (in HIBW mode, set PRBS_TYPE = 0)	0: GMSL default style PRBS test 1: MAX9272 style PRBS

**rceg (0x10)**

BIT	7	6	5	4	3	2	1	0
<b>Field</b>	RCEG_TYPE[1:0]		RCEG_BOUND	RCEG_ERR_NUM[3:0]			RCEG_EN	
<b>Reset</b>	00b		0b	0001b			0b	
<b>Access Type</b>	Write, Read		Write, Read	Write, Read			Write, Read	

BITFIELD	BITS	DESCRIPTION	DECODE
RCEG_TYPE	7:6	<b>Reverse-Channel Generated Error Type</b>	00: Random errors 01: Short burst 1X: Long burst
RCEG_BOUND	5	<b>Reverse-Channel Generated Error Boundary:</b> Effective when RCEG_TYPE_ = 0X)	0: Errors are unbounded to symbols 1: Errors are bounded to symbols
RCEG_ERR_NUM	4:1	<b>Number of RCEG Errors Generated:</b> Number of errors generated with each request Effective when RCEG_TYPE_ = 0X)	0000: Value is 0. 0001: Value is 1 XXXX 1111: Value is 15
RCEG_EN	0	<b>Enable Reverse-Channel Error Generator</b>	0: Disable reverse-channel error generator 1: Enable reverse-channel error generator

**rceg2 (0x11)**

BIT	7	6	5	4	3	2	1	0
<b>Field</b>	RCEG_ERR_RATE[3:0]				RCEG_LO_BST_PRB[1:0]		RCEG_LO_BST_LEN[1:0]	
<b>Reset</b>	1111b				00b		00b	
<b>Access Type</b>	Write, Read				Write, Read		Write, Read	

BITFIELD	BITS	DESCRIPTION	DECODE
RCEG_ERR_RATE	7:4	<b>Error-Generation Rate:</b> Error-generation rate in terms of bit time = $2^{(RCEG\_ERR\_RATE+3)}$ . Effective when RCEG_TYPE = 0X)	0000: Rate is $2^{-3}$ 0001: Rate is $2^{-4}$ 0010: Rate is $2^{-5}$ XXXX: Rate is $2^{-(3 + \text{value})}$ 1110: Rate is $2^{-17}$ 1111: Rate is $2^{-18}$
RCEG_LO_BST_PRB	3:2	<b>Long-Burst Error Probability:</b> Effective when RCEG_TYPE = 10)	00: 1/1024 01: 1/128 10: 1/32 11: 1/8
RCEG_LO_BST_LEN	1:0	<b>Long-Burst Error Length:</b> Long-burst error length in terms of bit time Effective when RCEG_TYPE = 10)	00: continuous 01: 128 (~150us) 10: 8192 (~9.83ms) 11: 1048576 (~1.26s)

line\_crc (0x12)

BIT	7	6	5	4	3	2	1	0
Field	UNDER- BST_DET_ EN	CC_CRC_ ERR_EN	LINE_CRC_LOC[1:0]		LINE_CRC_ EN	DIS_ RWAKE	MAX_RT_ ERR_EN	RCEG_ ERR_PER_ EN
Reset	0b	1b	01b		0b	0b	1b	0b
Access Type	Write, Read	Write, Read	Write, Read		Write, Read	Write, Read	Write, Read	Write, Read

BITFIELD	BITS	DESCRIPTION	DECODE
UNDERBST_DET_EN	7	<b>Underboost-Detection Enable:</b> Allow underboost detection driving ERRORB pin	0: Disable underboost detection driving ERROR pin 1: Enable underboost detection driving ERROR pin
CC_CRC_ERR_EN	6	<b>Control-Channel CRC ERR Enable:</b> Enable reporting of (CC_CRC_ERR_CNT -> 0) on the ERRB pin	0: Disable reporting of errors on ERRB 1: Enable reporting of errors on ERRB
LINE_CRC_LOC	5:4	<b>Video-Line CRC Insertion Location</b>	00: [1..4] 01: [5..8] 10: [9..12] 11: [13..16]
LINE_CRC_EN	3	<b>Video-Line CRC Enable</b>	0: Disable video-line CRC 1: Enable video-line CRC
DIS_RWAKE	2	<b>Disable Remote Wake-up</b>	0: Enable remote wake-up 1: Disable remote wake-up
MAX_RT_ERR_EN	1	<b>Enable Reflection of Maximum Retransmission Error:</b> Enable reflection of maximum retransmission error on the ERRORB pin	0: Disable maximum retransmission error on the ERROR pin 1: Enable maximum retransmission error on the ERROR pin
RCEG_ERR_PER_EN	0	<b>Periodic Error-Generation Enable:</b> Effective when RCEG_TYPE = 0X)	0: Disable periodic-error generator 1: Enable periodic-error generator

**ewm (0x13)**

BIT	7	6	5	4	3	2	1	0
<b>Field</b>	EWM_EN	EWM_PER_MODE	EWM_MAN_TRG_REQ	EWM_MIN_THR[4:0]				
<b>Reset</b>	1b	1b	0b	01101b				
<b>Access Type</b>	Write, Read	Write, Read	Write 1 to Set, Read	Write, Read				

BITFIELD	BITS	DESCRIPTION	DECODE
EWM_EN	7	<b>Eye-Width Monitor Enable</b>	0: Disable eye-width monitor 1: Enable eye-width monitor
EWM_PER_MODE	6	<b>Eye-Width Monitor Periodic Mode Select</b>	0: Set eye-width monitor to use nonperiodic mode 1: Set eye-width monitor to use periodic mode
EWM_MAN_TRG_REQ	5	<b>Eye-Width Manual Trigger Request:</b> Rising edge of this register triggers eye-width monitor when not in periodic mode	0: Do not trigger eye-width monitor. 1: Write 1 to this bit to manually trigger the eye-width monitor
EWM_MIN_THR	4:0	<b>Eye-Width Minimum Threshold:</b> Eye-width minimum threshold for flagging ERRORB pin	00000: Eye-width threshold is disabled XXXXX: (EWM_MIN_THR/64)% open eye flags ERROR pin

**aeq (0x14)**

BIT	7	6	5	4	3	2	1	0
<b>Field</b>	AEQ_EN	AEQ_PER_MODE	AEQ_MAN_TRG_REQ	EWM_PER_THR[4:0]				
<b>Reset</b>	1b	0b	0b	00000b				
<b>Access Type</b>	Write, Read	Write, Read	Write 1 to Set, Read	Write, Read				

BITFIELD	BITS	DESCRIPTION	DECODE
AEQ_EN	7	<b>Adaptive Equalization Enable:</b> Enable adaptive equalization	0: Disable AEQ 1: Enable AEQ
AEQ_PER_MODE	6	<b>Adaptive Equalization Periodic Mode Select</b>	0: Set AEQ to use nonperiodic mode 1: Set AEQ to use periodic mode
AEQ_MAN_TRG_REQ	5	<b>Adaptive Equalization Manual Fine-Tune Request:</b> Rising edge of this register triggers AEQ fine tuning when not in periodic mode	0: Do not trigger AEQ fine tuning 1: Write 1 to this bit to manually trigger the AEQ fine tuning
EWM_PER_THR	4:0	<b>Eye-Width Trigger Threshold:</b> Eye-width threshold to trigger a fine tune operation	00000: Eye-opening threshold is disabled 10000: 50% open-eye triggers fine-tune operation OTHER: <b>Do Not Use</b>

**det\_err (0x15)**

BIT	7	6	5	4	3	2	1	0
Field	DET_ERR[7:0]							
Reset	XXXXXXXXb							
Access Type	Read Only							

BITFIELD	BITS	DESCRIPTION	DECODE
DET_ERR	7:0	<b>Detected Error Counter</b>	00000000: Value is 0 00000001: Value is 1 XXXXXXXX 11111111: Value is 255.

**prbs\_err (0x16)**

BIT	7	6	5	4	3	2	1	0
Field	PRBS_ERR[7:0]							
Reset	XXXXXXXXb							
Access Type	Read Only							

BITFIELD	BITS	DESCRIPTION	DECODE
PRBS_ERR	7:0	<b>PRBS Error Counter</b>	00000000: Value is 0 00000001: Value is 1 XXXXXXXX 11111111: Value is 255

**If (0x17)**

BIT	7	6	5	4	3	2	1	0
Field	RSVD	MAX_RT_ERR	PRBS_OK	GPI_IN	LF_NEG[1:0]		LF_POS[1:0]	
Reset	Xb	Xb	Xb	Xb	XXb		XXb	
Access Type	Read Only	Read Clears All	Read Only	Read Only	Read Only		Read Only	

BITFIELD	BITS	DESCRIPTION	DECODE
RSVD	7	<b>Reserved:</b> Do not change from default value	X: Reserved
MAX_RT_ERR	6	<b>Maximum Retransmission Error Bit:</b> Goes high if packet control channel hits maximum retransmission limit (8 retries); cleared when read	0: No control-channel retransmission error 1: Control-channel retransmission maximum limit reached
PRBS_OK	5	<b>PRBS OK:</b> MAX9271/MAX9273-compatible PRBS test for link is terminated normally; check PRBS_ERR register for the PRBS success; for other SerDes read PRBS_ERR registers	0: No MAX9271/MAX9273-compatible PRBS test completed 1: MAX9271/MAX9273-compatible PRBS test completed normally
GPI_IN	4	<b>GPI Pin Level</b>	0: GPI is input low 1: GPI is input high
LF_NEG	3:2	<b>Line Fault:</b> Line-fault status of the indicated input LF_POS -> LMN0 LF_NEG -> LMN1	00: Short to battery detected 01: Short to ground detected 10: No faults detected 11: Open cable detected
LF_POS	1:0	<b>Line Fault:</b> Line-fault status of the indicated input LF_POS -> LMN0 LF_NEG -> LMN1	00: Short to battery detected 01: Short to ground detected 10: No faults detected 11: Open cable detected

**rsvd\_18 (0x18)**

<b>BIT</b>	<b>7</b>	<b>6</b>	<b>5</b>	<b>4</b>	<b>3</b>	<b>2</b>	<b>1</b>	<b>0</b>
<b>Field</b>	RSVD[7:0]							
<b>Reset</b>	XXXXXXXXb							
<b>Access Type</b>	Read Only							

<b>BITFIELD</b>	<b>BITS</b>	<b>DESCRIPTION</b>	<b>DECODE</b>
RSVD	7:0	<b>Reserved:</b> Do not change from default value	XXXXXXXX: Reserved

**cc\_crc\_errcnt (0x19)**

<b>BIT</b>	<b>7</b>	<b>6</b>	<b>5</b>	<b>4</b>	<b>3</b>	<b>2</b>	<b>1</b>	<b>0</b>
<b>Field</b>	CC_CRC_ERRCNT[7:0]							
<b>Reset</b>	XXXXXXXXb							
<b>Access Type</b>	Read Only							

<b>BITFIELD</b>	<b>BITS</b>	<b>DESCRIPTION</b>	<b>DECODE</b>
CC_CRC_ERRCNT	7:0	<b>Packet-Based Control-Channel CRC Error Counter</b>	00000000: Value is 0 00000001: Value is 1 XXXXXXXX 11111111: Value is 255

**rceg\_err\_cnt (0x1A)**

<b>BIT</b>	<b>7</b>	<b>6</b>	<b>5</b>	<b>4</b>	<b>3</b>	<b>2</b>	<b>1</b>	<b>0</b>
<b>Field</b>	RCEG_ERR_CNT[7:0]							
<b>Reset</b>	XXXXXXXXb							
<b>Access Type</b>	Read Only							

<b>BITFIELD</b>	<b>BITS</b>	<b>DESCRIPTION</b>	<b>DECODE</b>
RCEG_ERR_CNT	7:0	<b>Control-Channel Number of Generated Errors</b>	00000000: Value is 0 00000001: Value is 1. XXXXXXXX 11111111: Value is 255

**i2csel (0x1B)**

BIT	7	6	5	4	3	2	1	0
<b>Field</b>	RSVD	RSVD	RSVD	RSVD	I2CSEL	LINE_CRC_ERR	RSVD	RSVD
<b>Reset</b>	0b	0b	0b	0b	Xb	Xb	Xb	Xb
<b>Access Type</b>	Write, Read	Write, Read	Write, Read	Write, Read	Read Only	Read Clears All	Read Only	Read Only

BITFIELD	BITS	DESCRIPTION	DECODE
RSVD	7	<b>Reserved:</b> Do not change from default value	0: Reserved
RSVD	6	<b>Reserved:</b> Do not change from default value	0: Reserved
RSVD	5	<b>Reserved:</b> Do not change from default value	0: Reserved
RSVD	4	<b>Reserved:</b> Do not change from default value	0: Reserved
I2CSEL	3	<b>I2CSEL Pin Level:</b> Detected I2CSEL pin level	0: Low-I2CSEL pin detected (UART) 1: High-I2CSEL pin detected (I2C)
LINE_CRC_ERR	2	<b>CRC-Error Bit:</b> Goes high if received video line has CRC mismatch and latched; cleared to 0 when read	0: No line CRC error detected 1: Line CRC error detected
RSVD	1	<b>Reserved:</b> Do not change from default value	X: Reserved
RSVD	0	<b>Reserved:</b> Do not change from default value	X: Reserved

**ewm\_eye\_width (0x1C)**

BIT	7	6	5	4	3	2	1	0
<b>Field</b>	RSVD	RSVD	EOM_EYE_WIDTH[5:0]					
<b>Reset</b>	0b	0b	XXXXXXb					
<b>Access Type</b>	Write, Read	Write, Read	Read Only					

BITFIELD	BITS	DESCRIPTION	DECODE
RSVD	7	<b>Reserved:</b> Do not change from default value	0: Reserved
RSVD	6	<b>Reserved:</b> Do not change from default value	0: Reserved
EOM_EYE_WIDTH	5:0	<b>Measured Eye Opening:</b> Opening width = $EOM\_EYE\_WIDTH / 63 * 100\%$	000000: Width is 0% 000001: Width is 1/63 x 100% 111111: Width is 63/63 x 100%

aeq\_bst (0x1D)

BIT	7	6	5	4	3	2	1	0
Field	RSVD	RSVD	RSVD	UNDER-BOOST_DET	AEQ_BST[3:0]			
Reset	0b	0b	0b	Xb	XXXXb			
Access Type	Write, Read	Write, Read	Write, Read	Read Only	Read Only			

BITFIELD	BITS	DESCRIPTION	DECODE
RSVD	7	<b>Reserved:</b> Do not change from default value	0: Reserved
RSVD	6	<b>Reserved:</b> Do not change from default value	0: Reserved
RSVD	5	<b>Reserved:</b> Do not change from default value	0: Reserved
UNDERBOOST_DET	4	<b>Underboost Detected:</b> '1' indicates that an underboost is detected when the AEQ is at the maximum setting	0: Normal operation 1: Underboost (at maximum AEQ gain) detected
AEQ_BST	3:0	<b>Adaptive Equalizer Boost Value:</b> Selected adaptive equalizer value; settings correspond to gain at 750MHz	0000: 1.6dB EQ setting 0001: 2.1dB EQ setting 0010: 2.8dB EQ setting 0011: 3.5dB EQ setting 0100: 4.3dB EQ setting 0101: 5.2dB EQ setting 0110: 6.3dB EQ setting 0111: 7.3dB EQ setting 1000: 8.5dB EQ setting 1001: 9.7dB EQ setting 1010: 11dB EQ setting 1011: 12.2dB EQ setting 11XX: Reserved

id (0x1E)

BIT	7	6	5	4	3	2	1	0
Field	ID[7:0]							
Reset	XXXXXXXXb							
Access Type	Read Only							

BITFIELD	BITS	DESCRIPTION	DECODE
ID	7:0	<b>Device ID:</b> 8-bit value depends on the GMSL device attached	01001010: MAX96706

revision (0x1F)

BIT	7	6	5	4	3	2	1	0
Field	RSVD	RSVD	RSVD	HDCPCAP	REVISION[3:0]			
Reset	0b	0b	0b	Xb	XXXXb			
Access Type	Write, Read	Write, Read	Write, Read	Read Only	Read Only			

BITFIELD	BITS	DESCRIPTION	DECODE
RSVD	7	<b>Reserved:</b> Do not change from default value	0: Reserved
RSVD	6	<b>Reserved:</b> Do not change from default value	0: Reserved
RSVD	5	<b>Reserved:</b> Do not change from default value	0: Reserved
HDCPCAP	4	<b>HDCP Capability:</b> '1' = HDCP capable	0: Device does not have HDCP 1: Device is HDCP capable
REVISION	3:0	<b>Device Revision</b>	0000: Value is 0 0001: Value is 1 1111: Value is 15

crcvalue (0x20 to 0x23)

BIT	7	6	5	4	3	2	1	0
Field	CRCVALUE[7:0]							
Reset	XXXXXXXXb							
Access Type	Read Only							

BITFIELD	BITS	DESCRIPTION	DECODE
CRCVALUE	7:0	<b>CRC Value:</b> CRC output for latest line; CRC_VALUE_3 to CRC_VALUE_0 represents CRC[31:0].	00000000: Value is 0 00000001: Value is 1 11111111: Value is 255

crossbar (0x65 to 0x6B)

BIT	7	6	5	4	3	2	1	0
Field	CROSSBAR_N[3:0]				CROSSBAR_N+1[3:0]			
Reset	XXXXb				XXXXb			
Access Type	Write, Read				Write, Read			

BITFIELD	BITS	DESCRIPTION	DECODE
CROSSBAR_N	7:4	<b>Crossbar Setting:</b> CROSSBAR selects the internal signal to connect to the output pin, DOUT_. Register crossbar_(N) contains settings for two outputs, with CROSSBAR_(N) at D[7:4] and CROSSBAR_(N+1) at D[3:0]. Default settings for CROSSBAR(N) connects internal signal D(N) to its respective DOUT(N) pin.	0000: Connect D0 to output 0001: Connect D1 to output ::: 1101: Connect D13 to output 1110: Force output low 1111: Force output high
CROSSBAR_N+1	3:0	<b>Crossbar Setting:</b> CROSSBAR selects the internal signal to connect to the output pin, DOUT_. Register crossbar_(N) contains settings for two outputs, with CROSSBAR_(N) at D[7:4] and CROSSBAR_(N+1) at D[3:0]. Default settings for CROSSBAR(N) connects internal signal D(N) to its respective DOUT(N) pin.	0000: Connect D0 to output 0001: Connect D1 to output ::: 1101: Connect D13 to output 1110: Force output low 1111: Force output high

**rsvd\_96 (0x96)**

BIT	7	6	5	4	3	2	1	0
<b>Field</b>	RSVD[1:0]		RSVD[1:0]		RSVD	RSVD	RSVD	RSVD
<b>Reset</b>	01b		01b		0b	0b	0b	1b
<b>Access Type</b>	Write, Read		Write, Read		Write, Read	Write, Read	Write, Read	Write, Read

BITFIELD	BITS	DESCRIPTION	DECODE
RSVD	7:6	<b>Reserved:</b> Do not change from default value	01: Reserved
RSVD	5:4	<b>Reserved:</b> Do not change from default value	01: Reserved
RSVD	3	<b>Reserved:</b> Do not change from default value	0: Reserved
RSVD	2	<b>Reserved:</b> Do not change from default value	0: Reserved
RSVD	1	<b>Reserved:</b> Do not change from default value	0: Reserved
RSVD	0	<b>Reserved:</b> Do not change from default value	1: Reserved

**rev\_fast (0x97)**

BIT	7	6	5	4	3	2	1	0
<b>Field</b>	REV_FAST	RSVD	RSVD[5:0]					
<b>Reset</b>	0b	0b	100010b					
<b>Access Type</b>	Write, Read	Write, Read	Write, Read					

BITFIELD	BITS	DESCRIPTION	DECODE
REV_FAST	7	<b>Reverse-Channel Fast Mode</b>	0: Disable reverse-channel fast mode 1: Enable reverse-channel fast mode
RSVD	6	<b>Reserved:</b> Do not change from default value	0: Reserved
RSVD	5:0	<b>Reserved:</b> Do not change from default value	100010: Reserved

**rsvd\_98 (0x98)**

BIT	7	6	5	4	3	2	1	0
<b>Field</b>	RSVD	RSVD	RSVD[5:0]					
<b>Reset</b>	1b	0b	011010b					
<b>Access Type</b>	Write, Read	Write, Read	Write, Read					

BITFIELD	BITS	DESCRIPTION	DECODE
RSVD	7	<b>Reserved:</b> Do not change from default value	1: Reserved
RSVD	6	<b>Reserved:</b> Do not change from default value	0: Reserved
RSVD	5:0	<b>Reserved:</b> Do not change from default value	011010: Reserved

**rsvd\_99 (0x99)**

BIT	7	6	5	4	3	2	1	0
Field	RSVD	RSVD	RSVD	RSVD	RSVD	RSVD	RSVD	RSVD
Reset	0b	1b	0b	0b	0b	0b	0b	0b
Access Type	Write, Read	Write, Read	Write, Read	Write, Read	Write, Read	Write, Read	Write, Read	Write, Read

BITFIELD	BITS	DESCRIPTION	DECODE
RSVD	7	<b>Reserved:</b> Do not change from default value	0: Reserved
RSVD	6	<b>Reserved:</b> Do not change from default value	1: Reserved
RSVD	5	<b>Reserved:</b> Do not change from default value	0: Reserved
RSVD	4	<b>Reserved:</b> Do not change from default value	0: Reserved
RSVD	3	<b>Reserved:</b> Do not change from default value	0: Reserved
RSVD	2	<b>Reserved:</b> Do not change from default value	0: Reserved
RSVD	1	<b>Reserved:</b> Do not change from default value	0: Reserved
RSVD	0	<b>Reserved:</b> Do not change from default value	0: Reserved

**rsvd\_9a (0x9A)**

BIT	7	6	5	4	3	2	1	0
Field	RSVD	RSVD	RSVD[1:0]		RSVD[2:0]			RSVD
Reset	0b	0b	10b		010b			0b
Access Type	Write, Read	Write, Read	Write, Read		Write, Read			Write, Read

BITFIELD	BITS	DESCRIPTION	DECODE
RSVD	7	<b>Reserved:</b> Do not change from default value	0: Reserved
RSVD	6	<b>Reserved:</b> Do not change from default value	0: Reserved
RSVD	5:4	<b>Reserved:</b> Do not change from default value	10: Reserved
RSVD	3:1	<b>Reserved:</b> Do not change from default value	010: Reserved
RSVD	0	<b>Reserved:</b> Do not change from default value	0: Reserved

**rsvd\_9b (0x9B)**

BIT	7	6	5	4	3	2	1	0
Field	RSVD	RSVD[1:0]		RSVD[2:0]		RSVD[1:0]		
Reset	0b	01b		001b		10b		
Access Type	Write, Read	Write, Read		Write, Read		Write, Read		

BITFIELD	BITS	DESCRIPTION	DECODE
RSVD	7	<b>Reserved:</b> Do not change from default value	0: Reserved
RSVD	6:5	<b>Reserved:</b> Do not change from default value	01: Reserved
RSVD	4:2	<b>Reserved:</b> Do not change from default value	001: Reserved
RSVD	1:0	<b>Reserved:</b> Do not change from default value	10: Reserved

**rsvd\_9c (0x9C)**

BIT	7	6	5	4	3	2	1	0
Field	RSVD	RSVD[1:0]		RSVD	RSVD[3:0]			
Reset	0b	10b		1b	0100b			
Access Type	Write, Read	Write, Read		Write, Read	Write, Read			

BITFIELD	BITS	DESCRIPTION	DECODE
RSVD	7	<b>Reserved:</b> Do not change from default value	0: Reserved
RSVD	6:5	<b>Reserved:</b> Do not change from default value	10: Reserved
RSVD	4	<b>Reserved:</b> Do not change from default value	1: Reserved
RSVD	3:0	<b>Reserved:</b> Do not change from default value	0100: Reserved

**rsvd\_9d (0x9D)**

BIT	7	6	5	4	3	2	1	0
Field	RSVD	RSVD	RSVD	RSVD	SOFT_PD	RSVD	RSVD	RSVD
Reset	0b	0b	1b	01b	0b	0b	0b	0b
Access Type	Write, Read	Write, Read	Write, Read	Write, Read	Write 1 to Set, Read	Write, Read	Write, Read	Write, Read

BITFIELD	BITS	DESCRIPTION	DECODE
RSVD	7	<b>Reserved:</b> Do not change from default value	0: Reserved
RSVD	6	<b>Reserved:</b> Do not change from default value	0: Reserved
RSVD	5	<b>Reserved:</b> Do not change from default value	1: Reserved
RSVD	4	<b>Reserved:</b> Do not change from default value	01: Reserved
SOFT_PD	3	<b>Reserved:</b> Do not change from default value	0: Normal operation 1: Reset the device
RSVD	2	<b>Reserved:</b> Do not change from default value	0: Reserved
RSVD	1	<b>Reserved:</b> Do not change from default value	0: Reserved
RSVD	0	<b>Reserved:</b> Do not change from default value	0: Reserved

**rsvd\_9e (0x9E)**

BIT	7	6	5	4	3	2	1	0
<b>Field</b>	RSVD	RSVD[1:0]		RSVD[2:0]			RSVD	RSVD
<b>Reset</b>	1b	10b		010b			0b	0b
<b>Access Type</b>	Write, Read	Write, Read		Write, Read			Write, Read	Write, Read

BITFIELD	BITS	DESCRIPTION	DECODE
RSVD	7	<b>Reserved:</b> Do not change from default value	1: Reserved
RSVD	6:5	<b>Reserved:</b> Do not change from default value	10: Reserved
RSVD	4:2	<b>Reserved:</b> Do not change from default value	010: Reserved
RSVD	1	<b>Reserved:</b> Do not change from default value	0: Reserved
RSVD	0	<b>Reserved:</b> Do not change from default value	0: Reserved

**rsvd\_9f (0x9F)**

BIT	7	6	5	4	3	2	1	0
<b>Field</b>	RSVD	RSVD	RSVD	RSVD	RSVD	HPFTUNE[1:0]		RSVD
<b>Reset</b>	0b	0b	0b	0b	0b	01b		0b
<b>Access Type</b>	Write, Read	Write, Read	Write, Read	Write, Read	Write, Read	Write, Read		Write, Read

BITFIELD	BITS	DESCRIPTION	DECODE
RSVD	7	<b>Reserved:</b> Do not change from default value	0: Reserved
RSVD	6	<b>Reserved:</b> Do not change from default value	0: Reserved
RSVD	5	<b>Reserved:</b> Do not change from default value	0: Reserved
RSVD	4	<b>Reserved:</b> Do not change from default value	0: Reserved
RSVD	3	<b>Reserved:</b> Do not change from default value	0: Reserved
HPFTUNE	2:1	<b>Equalizer High-Pass Filter Cutoff Frequency</b>	00: 7.5MHz cutoff frequency 01: 3.75MHz cutoff frequency 10: 2.5MHz cutoff frequency 11: 1.87MHz cutoff frequency
RSVD	0	<b>Reserved:</b> Do not change from default value	0: Reserved

**rsvd\_a0 (0xA0)**

BIT	7	6	5	4	3	2	1	0
<b>Field</b>	RSVD	RSVD	RSVD[1:0]		RSVD[3:0]			
<b>Reset</b>	1b	0b	10b		1110b			
<b>Access Type</b>	Write, Read	Write, Read	Write, Read		Write, Read			

BITFIELD	BITS	DESCRIPTION	DECODE
RSVD	7	<b>Reserved:</b> Do not change from default value	1: Reserved
RSVD	6	<b>Reserved:</b> Do not change from default value	0: Reserved
RSVD	5:4	<b>Reserved:</b> Do not change from default value	10: Reserved
RSVD	3:0	<b>Reserved:</b> Do not change from default value	1110: Reserved

**rsvd\_a1(0xA1)**

BIT	7	6	5	4	3	2	1	0
Field	RSVD[2:0]			RSVD[4:0]				
Reset	010b			00100b				
Access Type	Write, Read			Write, Read				

BITFIELD	BITS	DESCRIPTION	DECODE
RSVD	7:5	Reserved: Do not change from default value	010: Reserved
RSVD	4:0	Reserved: Do not change from default value	00100: Reserved

**rsvd\_a2 (0xA2)**

BIT	7	6	5	4	3	2	1	0
Field	RSVD[7:0]							
Reset	00100000b							
Access Type	Write, Read							

BITFIELD	BITS	DESCRIPTION	DECODE
RSVD	7:0	Reserved: Do not change from default value	00100000: Reserved

**rsvd\_a3 (0xA3)**

BIT	7	6	5	4	3	2	1	0
Field	RSVD[3:0]			RSVD[3:0]				
Reset	0110b			1011b				
Access Type	Write, Read			Write, Read				

BITFIELD	BITS	DESCRIPTION	DECODE
RSVD	7:4	Reserved: Do not change from default value	0110: Reserved
RSVD	3:0	Reserved: Do not change from default value	1011: Reserved

**rsvd\_a4 (0xA4)**

BIT	7	6	5	4	3	2	1	0
Field	RSVD[2:0]		RSVD	RSVD	RSVD	RSVD[1:0]		
Reset	101b		1b	0b	1b	01b		
Access Type	Write, Read		Write, Read	Write, Read	Write, Read	Write, Read		

BITFIELD	BITS	DESCRIPTION	DECODE
RSVD	7:5	Reserved: Do not change from default value	101: Reserved
RSVD	4	Reserved: Do not change from default value	1: Reserved
RSVD	3	Reserved: Do not change from default value	0: Reserved
RSVD	2	Reserved: Do not change from default value	1: Reserved
RSVD	1:0	Reserved: Do not change from default value	01: Reserved

**rsvd\_a5 (0xA5)**

BIT	7	6	5	4	3	2	1	0
Field	RSVD[3:0]				RSVD[1:0]		RSVD[1:0]	
Reset	1100b				11b		01b	
Access Type	Write, Read				Write, Read		Write, Read	

BITFIELD	BITS	DESCRIPTION	DECODE
RSVD	7:4	<b>Reserved:</b> Do not change from default value	1100: Reserved
RSVD	3:2	<b>Reserved:</b> Do not change from default value	11: Reserved
RSVD	1:0	<b>Reserved:</b> Do not change from default value	01: Reserved

**rsvd\_a6 (0xA6)**

BIT	7	6	5	4	3	2	1	0
Field	RSVD	RSVD	RSVD	RSVD	RSVD[1:0]		RSVD[1:0]	
Reset	0b	0b	0b	0b	00b		01b	
Access Type	Write, Read	Write, Read	Write, Read	Write, Read	Write, Read		Write, Read	

BITFIELD	BITS	DESCRIPTION	DECODE
RSVD	7	<b>Reserved:</b> Do not change from default value	0: Reserved
RSVD	6	<b>Reserved:</b> Do not change from default value	0: Reserved
RSVD	5	<b>Reserved:</b> Do not change from default value	0: Reserved
RSVD	4	<b>Reserved:</b> Do not change from default value	0: Reserved
RSVD	3:2	<b>Reserved:</b> Do not change from default value	00: Reserved
RSVD	1:0	<b>Reserved:</b> Do not change from default value	01: Reserved

**rsvd\_c9 (0xC9)**

BIT	7	6	5	4	3	2	1	0
Field	RSVD[7:0]							
Reset	XXXXXXXXb							
Access Type	Read Only							

BITFIELD	BITS	DESCRIPTION	DECODE
RSVD	7:0	<b>Reserved:</b> Do not change from default value	XXXXXXXX: Reserved

**rsvd\_ca (0xCA)**

BIT	7	6	5	4	3	2	1	0
<b>Field</b>	RSVD	RSVD	RSVD	RSVD[1:0]		RSVD	RSVD	RSVD
<b>Reset</b>	0b	Xb	Xb	XXb		Xb	Xb	Xb
<b>Access Type</b>	Write, Read	Read Only	Read Only	Read Only		Read Only	Read Only	Read Only

BITFIELD	BITS	DESCRIPTION	DECODE
RSVD	7	<b>Reserved:</b> Do not change from default value	0: Reserved
RSVD	6	<b>Reserved:</b> Do not change from default value	X: Reserved
RSVD	5	<b>Reserved:</b> Do not change from default value	X: Reserved
RSVD	4:3	<b>Reserved:</b> Do not change from default value	XX: Reserved
RSVD	2	<b>Reserved:</b> Do not change from default value	X: Reserved
RSVD	1	<b>Reserved:</b> Do not change from default value	X: Reserved
RSVD	0	<b>Reserved:</b> Do not change from default value	X: Reserved

**cc\_locked (0xCB)**

BIT	7	6	5	4	3	2	1	0
<b>Field</b>	RSVD	RSVD	RSVD	RSVD	CC_WBLOCK	REM_CCLOCK	CC_WBLOCK_LOST	RSVD
<b>Reset</b>	Xb	Xb	Xb	Xb	Xb	Xb	Xb	0b
<b>Access Type</b>	Read Only	Read Only	Read Only	Read Only	Read Only	Read Only	Read Only	Write, Read

BITFIELD	BITS	DESCRIPTION	DECODE
RSVD	7	<b>Reserved:</b> Do not change from default value	X: Reserved
RSVD	6	<b>Reserved:</b> Do not change from default value	X: Reserved
RSVD	5	<b>Reserved:</b> Do not change from default value	X: Reserved
RSVD	4	<b>Reserved:</b> Do not change from default value	X: Reserved
CC_WBLOCK	3	<b>Control-Channel Word Boundary Locked:</b> '1' indicates locked.	0: Control-channel word boundary not locked. 1: Control-channel word boundary locked.
REM_CCLOCK	2	<b>Remote-Side CC Locked:</b> '1' indicates remote side CC locked.	0: Remote-side control channel not locked. 1: Remote-side control channel locked.
CC_WBLOCK_LOST	1	<b>Word-Boundary Lock Lost:</b> This bit is set to 1 when reverse control-channel word boundary loses lock. It is cleared when read.	0: Normal operation 1: Control-channel word boundary lost lock.
RSVD	0	<b>Reserved:</b> Do not change from default value	0: Reserved

**rsvd\_cc (0xCC)**

<b>BIT</b>	<b>7</b>	<b>6</b>	<b>5</b>	<b>4</b>	<b>3</b>	<b>2</b>	<b>1</b>	<b>0</b>
<b>Field</b>	RSVD	RSVD[6:0]						
<b>Reset</b>	0b	XXXXXXXXb						
<b>Access Type</b>	Write, Read	Read Only						

<b>BITFIELD</b>	<b>BITS</b>	<b>DESCRIPTION</b>	<b>DECODE</b>
RSVD	7	<b>Reserved:</b> Do not change from default value	0: Reserved
RSVD	6:0	<b>Reserved:</b> Do not change from default value	XXXXXXXX: Reserved

**rsvd\_cd (0xCD)**

<b>BIT</b>	<b>7</b>	<b>6</b>	<b>5</b>	<b>4</b>	<b>3</b>	<b>2</b>	<b>1</b>	<b>0</b>
<b>Field</b>	RSVD	RSVD[6:0]						
<b>Reset</b>	0b	XXXXXXXXb						
<b>Access Type</b>	Write, Read	Read Only						

<b>BITFIELD</b>	<b>BITS</b>	<b>DESCRIPTION</b>	<b>DECODE</b>
RSVD	7	<b>Reserved:</b> Do not change from default value	0: Reserved
RSVD	6:0	<b>Reserved:</b> Do not change from default value	XXXXXXXX: Reserved

**rsvd\_fd (0xFD)**

<b>BIT</b>	<b>7</b>	<b>6</b>	<b>5</b>	<b>4</b>	<b>3</b>	<b>2</b>	<b>1</b>	<b>0</b>
<b>Field</b>	RSVD[7:0]							
<b>Reset</b>	0b							
<b>Access Type</b>	Write, Read							

<b>BITFIELD</b>	<b>BITS</b>	<b>DESCRIPTION</b>	<b>DECODE</b>
RSVD	7:0	<b>Reserved:</b> Do not change from default value	0: Reserved

**rsvd\_fe (0xFE)**

<b>BIT</b>	<b>7</b>	<b>6</b>	<b>5</b>	<b>4</b>	<b>3</b>	<b>2</b>	<b>1</b>	<b>0</b>
<b>Field</b>	RSVD[3:0]				RSVD[3:0]			
<b>Reset</b>	0b				0b			
<b>Access Type</b>	Write, Read				Write, Read			

<b>BITFIELD</b>	<b>BITS</b>	<b>DESCRIPTION</b>	<b>DECODE</b>
RSVD	7:4	<b>Reserved:</b> Do not change from default value	0: Reserved
RSVD	3:0	<b>Reserved:</b> Do not change from default value	0: Reserved

## rsvd\_ff (0xFF)

BIT	7	6	5	4	3	2	1	0
Field	RSVD	RSVD	RSVD	RSVD	RSVD[3:0]			
Reset	0b	0b	0b	0b	XXXXb			
Access Type	Write, Read	Write, Read	Write, Read	Write, Read	Read Only			

BITFIELD	BITS	DESCRIPTION	DECODE
RSVD	7	<b>Reserved:</b> Do not change from default value	0: Reserved
RSVD	6	<b>Reserved:</b> Do not change from default value	0: Reserved
RSVD	5	<b>Reserved:</b> Do not change from default value	0: Reserved
RSVD	4	<b>Reserved:</b> Do not change from default value	0: Reserved
RSVD	3:0	<b>Reserved:</b> Do not change from default value	XXXX: Reserved

## Applications Information

### Parallel Interface

The CMOS parallel-interface data width is programmable and depends on the application. Using a larger width (BWS = 1) results in a lower-pixel clock rate, while a smaller width (BWS = 0) allows a higher-pixel clock rate.

### Bus Data Width

The bus data width depends on the selected modes. The available bus width is less when using error detection or when in double mode (DBL = 1). [Table 3](#) shows the available bit widths and default mapping for various modes.

**Table 3. Output-Data Width Selection**

REGISTER BIT SETTINGS					OUTPUT MAPPING
DBL	BWS	HIBW	PXL_CRC	HVEN	
1	1	—	1	1	DOUT11:0, HS, VS
1	1	—	1	0	DOUT11:0
1	1	—	0	1	DOUT11:0*, HS, VS
1	1	—	0	0	DOUT13:0*
1	0	1	1	—	DOUT8:0, HS, VS
1	0	1	0	—	DOUT11:0, HS, VS
1	0	0	1	1	DOUT7:0, HS, VS
1	0	0	1	0	DOUT7:0
1	0	0	0	1	DOUT10:0, HS, VS
1	0	0	0	0	DOUT10:0
0	1	—	1	1	DOUT11:0*, HS, VS
0	1	—	1	0	DOUT13:0*
0	1	—	0	1	DOUT11:0*, HS, VS
0	1	—	0	0	DOUT13:0*
0	0	1	—	—	DOUT11:0*, HS, VS
0	0	0	1	1	DOUT11:0*, HS, VS
0	0	0	1	0	DOUT13:0*
0	0	0	0	1	DOUT11:0*, HS, VS
0	0	0	0	0	DOUT13:0*

\*The bit width is limited by the number of available outputs.

### Bus Data Rates

The bus data rate depends on the settings BWS and DBL. [Table 4](#) lists the available PCLK rates available for different bus-width settings. For lower PCLK rates, set DBL = 0 (if DBL = 1 in both the serializer and deserializer).

### Crossbar Switch

By default, the crossbar switch connects the serializer input pins DIN\_ and HS/VS (when HV encoding is used) to the corresponding deserializer output pins DOUT\_ and HS/VS when DBL of the serializer and deserializer match. When there is a DBL mismatch use [Tables 5 - 7](#) to map the serial bits to the crossbar inputs. Reprogram the crossbar switch when changing the output pin assignments.

### Crossbar Switch Programming

Each output pin can be assigned any of the 14 DOUT signals. Multiple outputs can share the same input. To force an output low, and ignore the input, set CROSSBAR\_bit = 1110. To force an output high set CROSSBAR\_ = 1111.

### Recommended Crossbar Switch Programming Procedure

The following procedure programs the crossbar switch to reassign input/output pin locations:

- 1) For the crossbar output equivalent of DOUT0 (XBO0) select which pin to map (e.g., DOUT4 -> XBI4).
- 2) Set the crossbar bits (CROSSBAR0) to the desired selected mapped input (e.g., CROSSBAR0 = 0100).
- 3) Repeat for the other crossbar outputs.

**Table 4. Data-Rate Selection Table**

DRS	DBL	BWS	HIBW	PCLK RANGE (MHZ)
0	1	1	0	25 to 87
0	1	0	0	33.3 to 116
0	1	0	1	73.3 to 116
0	0	1	0	12.5 to 43.5
0	0	0	0	16.7 to 58
0	0	0	1	36.7 to 58
1*	0	1	0	6.25 to 12.5
1*	0	0	0	8.33 to 16.7

\*Use DRS = 1 with legacy devices only (MAX92XX).

**Table 5. Output Map (DBL = 0 or DBL = 1, First Word)**

BIT SETTING							OUTPUT BITS (FIRST WORD)													
DB	HV	BW	HB	CR	DE	SC*	A0	A1	A2	A3	A4	A5	A6	A7	A8	A9	A10	A11	A12	A13
0	0	X	0	X	0	1	0	1	2	3	4	5	6	7	8	9	10	11	14	15
0	0	X	0	X	1	1	0	1	2	3	4	5	6	7	8	9	10	13	14	15
0	0	X	0	X	X	2	0	1	2	3	4	5	6	7	8	9	10	11	12	13
0	1	X	0	X	1	1	0	1	2	3	4	5	6	7	8	9	10	13	H	V
0	1	X	0	X	1	2	0	1	2	3	4	5	6	7	8	9	10	11	H	V
0	1	X	0	X	0	1,2	0	1	2	3	4	5	6	7	8	9	10	11	H	V
0	0	0	1	X	0	0	0	1	2	3	4	5	6	7	8	9	10	11	H	V
0	0	0	1	X	1	0	0	1	2	3	4	5	6	7	8	9	10	D	H	V
1	0	0	0	0	X	3	0	1	2	3	4	5	6	7	8	9	10	Z	Z	Z
1	0	0	0	1	X	3	0	1	2	3	4	5	6	7	Z	Z	Z	Z	Z	Z
1	0	1	0	0	X	3	0	1	2	3	4	5	6	7	8	9	10	11	12	13
1	0	1	0	1	X	3	0	1	2	3	4	5	6	7	8	9	10	11	Z	Z
1	1	0	0	0	0	1,2	0	1	2	3	4	5	6	7	8	9	10	Z	HL	VL
1	1	0	0	0	1	1,2	0	1	2	3	4	5	6	7	8	9	Z	10	HL	VL
1	1	0	0	1	0	1,2	0	1	2	3	4	5	6	7	Z	Z	Z	Z	HL	VL
1	1	0	0	1	1	1,2	0	1	2	3	4	5	6	Z	Z	Z	Z	7	HL	VL
1	1	1	0	0	1	1	0	1	2	3	4	5	6	7	8	9	10	13	HL	VL
1	1	1	0	0	1	2	0	1	2	3	4	5	6	7	8	9	10	11	HL	VL
1	1	1	0	0	0	1,2	0	1	2	3	4	5	6	7	8	9	10	11	HL	VL
1	1	1	0	1	X	1,2	0	1	2	3	4	5	6	7	8	9	10	11	HL	VL
1	0	0	1	0	0	0	0	1	2	3	4	5	6	7	8	9	10	11	HL	VL
1	0	0	1	0	1	0	0	1	2	3	4	5	6	7	8	9	10	DL	HL	VL
1	0	0	1	1	0	0	0	1	2	3	4	5	6	7	8	Z	Z	Z	HL	VL
1	0	0	1	1	1	0	0	1	2	3	4	5	6	7	8	Z	Z	DL	HL	VL

**Table 6. Output Map (DBL = 1, Second Word)**

BIT SETTING							OUTPUT BITS (SECOND WORD)													
DB	HV	BW	HB	CR	DE	SC*	B0	B1	B2	B3	B4	B5	B6	B7	B8	B9	B10	B11	B12	B13
1	0	0	0	0	X	3	11	12	13	14	15	16	17	18	19	20	21	Z	Z	Z
1	0	0	0	1	X	3	8	9	10	11	12	13	14	15	Z	Z	Z	Z	Z	Z
1	0	1	0	0	X	3	15	16	17	18	19	20	21	22	23	24	25	26	27	28
1	0	1	0	1	X	3	12	13	14	15	16	17	18	19	20	21	22	23	Z	Z
1	1	0	0	0	0	1,2	11	12	13	14	15	16	17	18	19	20	21	Z	HH	VH
1	1	0	0	0	1	1,2	11	12	13	14	15	16	17	18	19	20	Z	21	HH	VH
1	1	0	0	1	0	1,2	8	9	10	11	12	13	14	15	Z	Z	Z	Z	HH	VH
1	1	0	0	1	1	1,2	8	9	10	11	12	13	14	Z	Z	Z	Z	15	HH	VH
1	1	1	0	0	1	1	15	16	17	18	19	20	21	22	23	24	25	28	HH	VH
1	1	1	0	0	1	2	15	16	17	18	19	20	21	22	23	24	25	26	HH	VH
1	1	1	0	0	0	1,2	15	16	17	18	19	20	21	22	23	24	25	26	HH	VH
1	1	1	0	1	X	1,2	12	13	14	15	16	17	18	19	20	21	22	23	HH	VH
1	0	0	1	0	0	0	12	13	14	15	16	17	18	19	20	24	25	26	HH	VH
1	0	0	1	0	1	0	12	13	14	15	16	17	18	19	20	24	25	DH	HH	VH
1	0	0	1	1	0	0	9	10	11	12	13	14	15	16	17	Z	Z	Z	HH	VH
1	0	0	1	1	1	0	9	10	11	12	13	14	15	16	17	Z	Z	DH	HH	VH

**Table 7. Legend**

BIT SETTINGS		MAPPED SYNC OUTPUTS	
DB	Double mode bit DBL	H	HSYNC ( when DBL = 0)
HV	H/V Encoding bit HVEN	V	VSYNC ( when DBL = 0)
BW	BWS bit	D	DE ( when DBL = 0)
HB	HIBW bit	HH	HSYNC (high word, DBL = 1)
CR	PXL_CRC bit	VH	VSYNC (high word, DBL = 1)
DE	DEEN	DH	DE (high word, DBL = 1)
SC*	HV_SRC (dec)	HL	HSYNC (low word, DBL = 1)
X	1 or 0	VL	VSYNC (low word, DBL = 1)
<b>BIT COLOR</b>		DL	DE (low word, DBL = 1)
	Sync Bits	#	Serial Bits
	Output on first word	Z	Zero
	Output on second word		
	Zero		

\*HV\_SRC is automatically set by default. MAX96705 mode automatically sets HV\_SRC to 0, 1, or 3 according to the other bit settings above. MAX96707 mode automatically sets HV\_SRC to 0, 2, or 3 according to the other bit settings above.

## Control-Channel Interfaces

### I<sup>2</sup>C

Set I2CSEL = 1 to configure the control channel for I<sup>2</sup>C-to-I<sup>2</sup>C mode. In this mode, the control channel forwards I<sup>2</sup>C commands from the microcontroller side to the other side of the GMSL link. The remote device acts as an I<sup>2</sup>C master to the other peripherals connected to the remote side device. I<sup>2</sup>C-to-I<sup>2</sup>C mode uses clock stretching to hold the microcontroller until the data and the acknowledge/no-acknowledge have been sent across the link.

### I<sup>2</sup>C Bit Rate

The I<sup>2</sup>C interface accepts bit rates from 9.6kbps to 1Mbps. The local I<sup>2</sup>C rate is set by the microcontroller. The remote I<sup>2</sup>C rate is set by the remote device. By default the control channel is set up for a 400kbps-to-I<sup>2</sup>C bit rate. Program the I2C\_MSTBT and SLV\_SH bits (register 0x0D) to match the desired microcontroller I<sup>2</sup>C rate.

## Software Programming of the Device Addresses

The serializer and deserializer have programmable device addresses. This allows multiple GMSL devices, along with I<sup>2</sup>C peripherals, to coexist on the same control channel. The serializer device address is in register 0x00 of each device, while the deserializer device address is in register 0x01 of each device. To change a device address, first write to the device whose address changes (register 0x00 of the serializer for serializer device address change, or register 0x01 of the deserializer for deserializer device address change). Then write the same address into the corresponding register on the other device (register 0x00 of the deserializer for serializer device address change, or register 0x01 of the serializer for deserializer device address change).

### I<sup>2</sup>C Address Translation

The device supports I<sup>2</sup>C address translation for up to two device addresses. Use address translation to assign unique device addresses to peripherals with limited I<sup>2</sup>C addresses. Source addresses (address to translate from) are stored in registers 0x09 and 0x0B. Destination addresses (address to translate to) are stored in registers 0x0A and 0x0C.

### Configuration Blocking

The device can block changes to its registers. Set CFGBLOCK to make all registers read only. Once set, the registers remain blocked until the supplies are removed or until PWDNB is low.

## Cascaded/Parallel Devices

GMSL supports cascaded and parallel devices connected through I<sup>2</sup>C. When cascading or using parallel links, all I<sup>2</sup>C commands are forwarded to all links. Each link attempts to hold the control channel until it receives an acknowledge/non-acknowledge from the remote side device. It is important to keep the control channel active between links in order to prevent timeout. If a link is unused, keep the control channel clear by turning on the configuration link, disconnecting the I<sup>2</sup>C lines, or powering down the unused device.

### Dual $\mu$ C Control

Most systems use a single microcontroller; however,  $\mu$ Cs can reside on each side simultaneously and trade off running the control channel. Contention occurs if both  $\mu$ Cs attempt to use the control channel at the same time. It is up to the user to prevent this contention by implementing a higher-level protocol. In addition, the control channel does not provide arbitration between I<sup>2</sup>C masters on both sides of the link. An acknowledge frame is not generated when communication fails due to contention. If communication across the serial link is not required, the  $\mu$ Cs can disable the forward and reverse control channel using the FWDCCEN and REVCCEN bits (0x04, D[1:0]) in the serializer/deserializer. Communication across the serial link is stopped and contention between  $\mu$ Cs cannot occur.

### Packet-Based Control-Channel I<sup>2</sup>C

Packet-based control-channel I<sup>2</sup>C is not enabled by default. To enable packet-based I<sup>2</sup>C, set PKTCC\_EN = 1 in the deserializer and wait 2ms. During this time, the deserializer automatically enables packet-based control channel in the serializer.

The internal bit rate used by the packet control channel does not depend on the I<sup>2</sup>C bit rate used by the host  $\mu$ C. The raw forward control channel bit rate is the same as PCLK (e.g., 10Mbps when f<sub>PCLK</sub> is 10MHz). The raw reverse-channel bit rate is 850kbps typically (425kbps when HIM = 1). The packet length is 9 bits + the CRC bit length, and affects the overall symbol rate. A larger CRC bit length lowers the overall symbol rate.

The latency of GPI/GPO transitions depend on the packet length. The latency of an I<sup>2</sup>C transmission across the control channel depends on both the incoming/outgoing SCL rate and the control-channel symbol rate. Sending a single byte from serializer to deserializer has an additional delay of 4 SCL bit times + 1.5 symbols. Sending a single byte from deserializer to serializer has an additional delay of 5 SCL bit times + 1.5 Symbols.

**UART**

Set I2CSEL = 0 to configure the control channel for UART or UART to I<sup>2</sup>C. In this mode, the control channel forwards UART commands from the microcontroller side to the other side of the GMSL link. When INTTYPE = 00, the remote device acts as an I<sup>2</sup>C master to the other peripherals connected to the remote side device. UART-to-I<sup>2</sup>C mode does not support devices that use clock stretching.

**Base Mode**

In base mode, UART packets control the serializer, deserializer and attached peripherals.

**UART Timing**

In base mode, the UART idles high (through a pullup resistor). Each GMSL-UART byte consists of a START bit, 8 data bits, an even-parity bit and a stop bit (Figure 20). Keep the idle time between bytes of the same UART packet to less than 4 bit times. The GMSL-UART protocol is listed in Figure 21. A write packet consists of a SYNC byte (Figure 22). Device address byte, Starting register address byte, number of bytes to write, and the data bytes. The slave device responds with an acknowledge byte (Figure 23) if the write was successful. A Read packet consists of a SYNC byte, Device address byte, Starting register address byte, and number of bytes to read. The slave device responds with an acknowledge byte and the read data bytes.

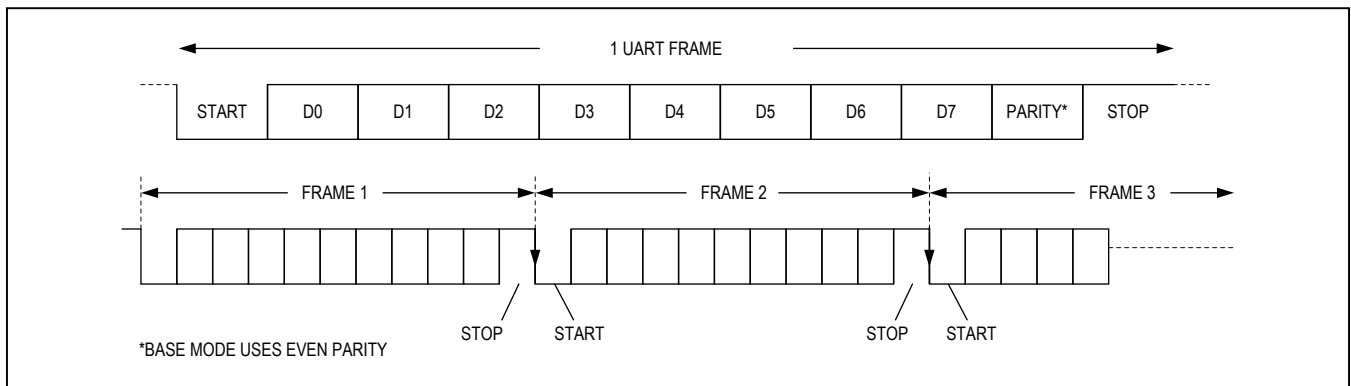

Figure 20. GMSL-UART Data Format for Base Mode

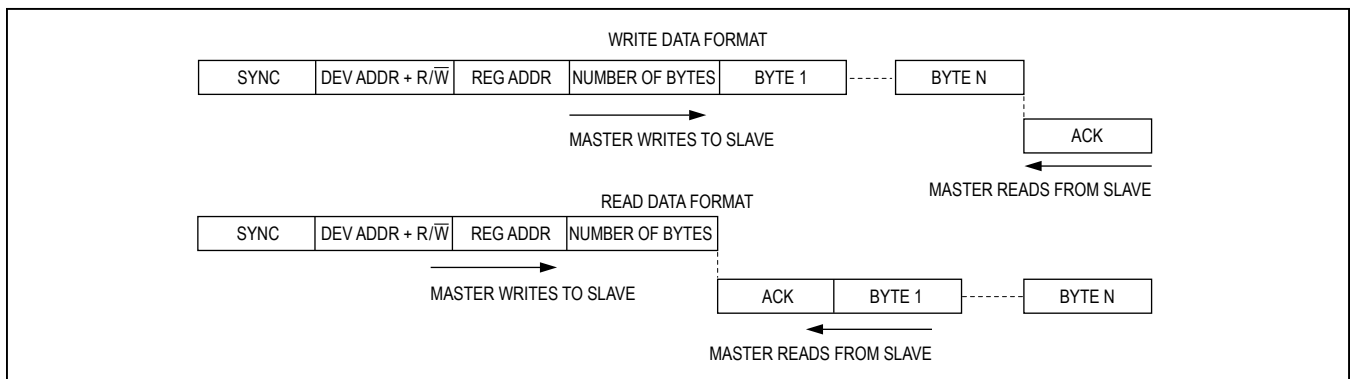

Figure 21. GMSL-UART Protocol for Base Mode

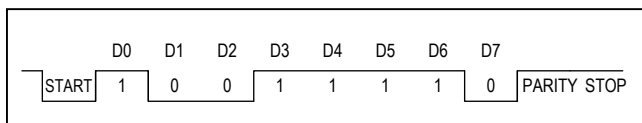

Figure 22. SYNC Byte (0x79)

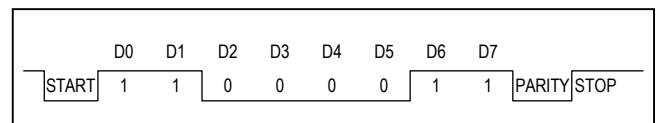

Figure 23. ACK Byte (0xC3)

**UART-to-I<sup>2</sup>C Conversion**

When using the UART control channel, the remote-side device can communicate to I<sup>2</sup>C peripherals through UART-to-I<sup>2</sup>C conversion. Set the INTTYPE bits in the remote side device to "00" to activate UART-to-I<sup>2</sup>C conversion. The converted I<sup>2</sup>C bit rate is the same as the incoming UART bit rate. I<sup>2</sup>C peripherals must not use clock stretching in order to be compatible with UART-to-I<sup>2</sup>C conversion.

There are two possible methods the devices use to convert UART to I<sup>2</sup>C. In the first method, I<sup>2</sup>CMETHOD = 0. The register address is sent with the I<sup>2</sup>C communication (Figure 24). For devices that do not use a register address (such as the MAX7324) set I<sup>2</sup>CMETHOD = 1 and send a dummy byte in place of the register address (Figure 25). In this method, the remote device omits sending the register address.

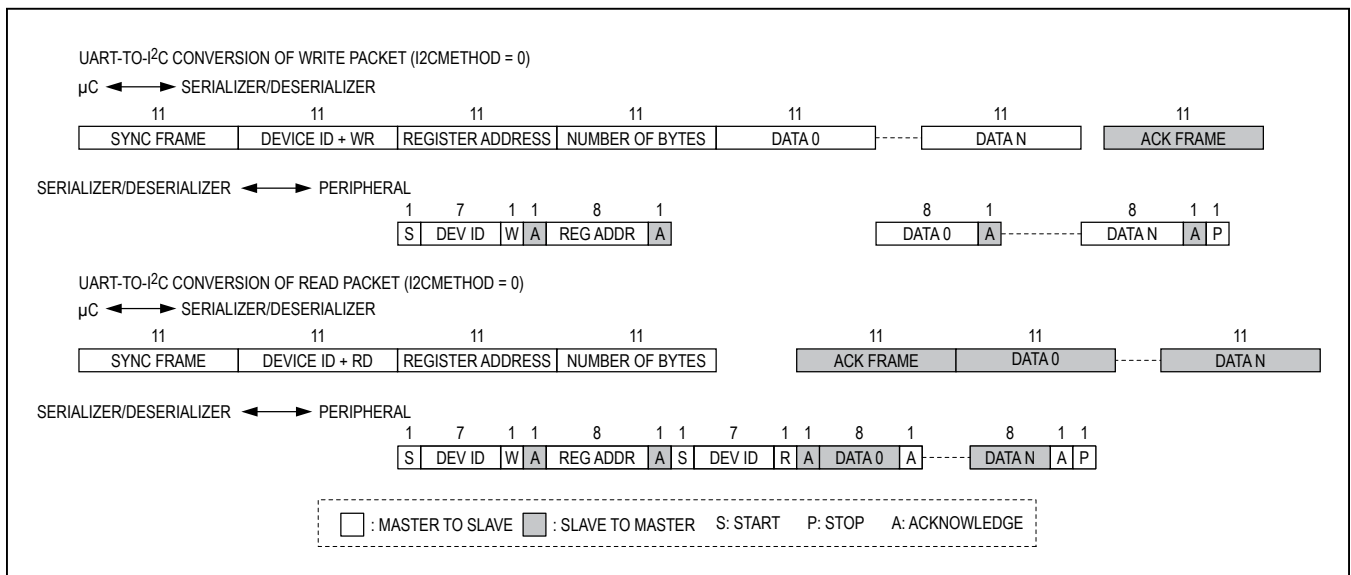

Figure 24. Format Conversion Between GMSL UART and I<sup>2</sup>C with Register Address (I<sup>2</sup>CMETHOD = 0)

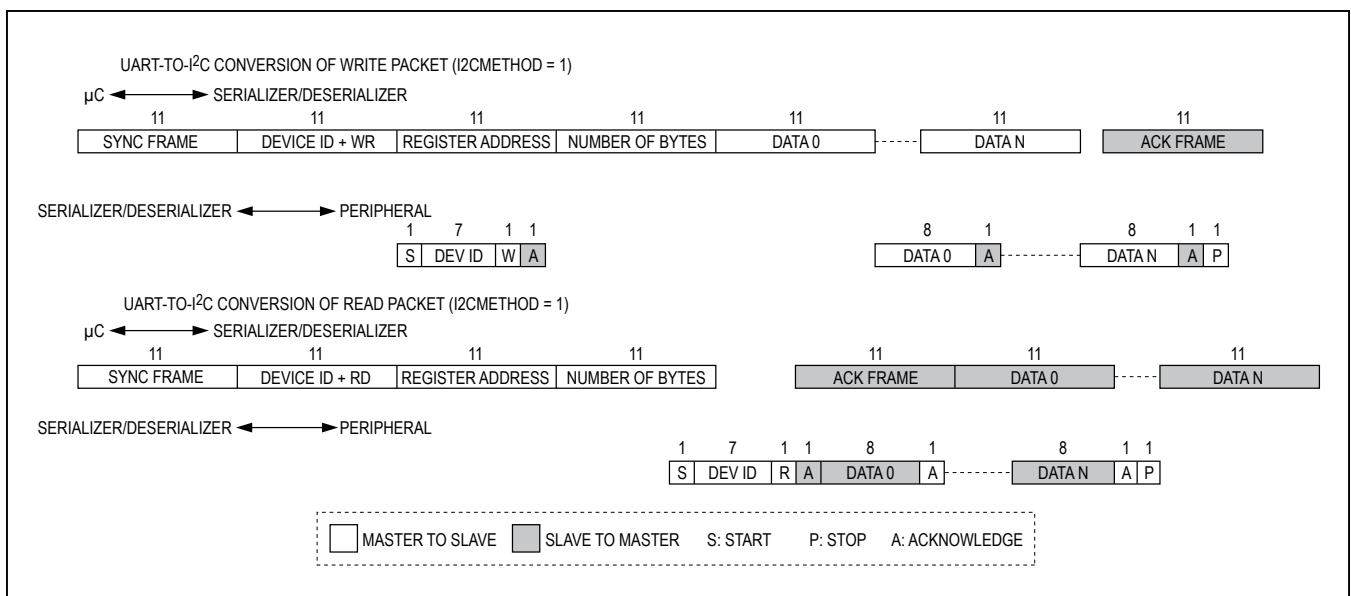

Figure 25. Format Conversion Between GMSL UART and I<sup>2</sup>C without Register Address (I<sup>2</sup>CMETHOD = 1)

**Table 8. Default-Device Address**

D7	D6	D5	D4	D3	D2	D1	D0
1	ADD3	ADD2	1	ADD1	ADD0	0	R/W

**Note:** ADD[3:0] pin settings latched at power-up.

### UART Bypass Mode

In UART bypass mode, the control channel acts as a full-duplex 9.6kbps to 1Mbps link that forwards UART commands across the serial link without responding to the packets themselves. Set MS high to enter bypass mode (wait 1ms after setting bypass mode if the  $\mu$ C is connected on the deserializer side). Bypass uses bit rates from 9.6kbps to 1Mbps. Do not send a logic-low value longer than 100 $\mu$ s when using the GPI/GPO functionality.

### Device Address

The SerDes have a 7-bit-long slave address stored in registers 0x00 and 0x01. The bit following a 7-bit slave address is the R/W bit, which is low for a write command and high for a read command. External inputs determine the default slave address as shown in Table 8. After start-up, a microcontroller can reprogram the slave address as needed.

### Cable Equalizer

By default, the cable equalizer is enabled and set to Adaptive mode. Set AEQ\_EN = 0 to switch to manual EQ mode. EQTUNE determines the boost level in manual EQ mode (see Table 9). Set EN\_EQ = 0 to disable all equalization (manual or automatic).

The auto-equalization level is determined during serial-link locking. Set AEQ\_MAN\_TRG\_REQ = 1 to re-trigger auto equalization. Set AEQ\_PER\_MODE = 1 to set up periodic AEQ.

### ERRB Output

The deserializer has an open-drain ERRB output. This output asserts low whenever any of the following conditions occur:

- The number of detected errors exceeds the error thresholds during normal operation. Read DET\_ERR, set auto-error reset, or re-lock the link to clear.
- Exceeding the maximum number control channel retries. Read MAX\_RT\_ERR to clear.
- Measured eye width falls below a programmable threshold (40% by default). Re-trigger an eye-width measurement (above the threshold) to clear.

**Table 9. Cable-Equalizer Boost Levels**

BOOST SETTING (MANUAL AND ADAPTIVE EQ)	TYPICAL BOOST GAIN AT 750MHZ (DB)
0000	1.6
0001	2.1
0010	2.8
0011	3.5
0100	4.3
0101	5.2
0110	6.3
0111	7.3
1000	8.5
1001	9.7 Power-up default for Manual EQ*
1010	11.0
1011	12.2

\*Automatic EQ is enabled by default.

Additional conditions that set ERRB (disabled by default) include:

- Insufficient boost at maximum boost setting (set UNDERBST\_DET\_EN = 1). Retrigger the equalization calibration to clear.
- Control-channel CRC errors (set CC\_CRC\_ERR\_EN = 1 to enable). Read CC\_CRC\_ERRCNT to clear. Requires packet control channel (PKTCC = 1).
- Video line CRC errors (turn on video-line CRC to enable). Read LINE\_CRC\_ERR to clear.

### Auto-Error Reset

The default method to reset errors is to read the respective error counter registers in the deserializer. Auto-error reset clears the error counters DET\_ERR ~1 $\mu$ s after ERR goes low. Auto-error reset is disabled on power-up. Enable auto-error reset through ERR\_RST. Auto-error reset does not run when the device is in PRBS test mode.

**Board Layout**

**Power-Supply Circuits and Bypassing**

The deserializer uses an AVDD and DVDD of 1.7V to 1.9V. All inputs and outputs, except for the serial input, derive power from an IOVDD of 1.7V to 3.6V that scales with IOVDD. Proper voltage-supply bypassing is essential for high-frequency circuit stability.

**High-Frequency Signals**

Separate the LVCMOS logic signals and CML/coax high-speed signals to prevent crosstalk. Use a four-layer PCB with separate layers for power, ground, CML/coax, and LVCMOS logic signals. Layout STP PCB traces close to each other for a 100Ω differential characteristic impedance. The trace dimensions depend on the type of trace used (microstrip or stripline). Note that two 50Ω PCB traces do not have 100Ω differential impedance when brought close together—the impedance goes down when the traces are brought closer. Use a 50Ω trace for the single-ended output when driving coax. Route the PCB traces for differential CML in parallel to maintain the differential characteristic impedance. Avoid vias. Keep PCB traces that make up a differential pair equal in length to avoid skew within the differential pair.

**ESD Protection**

ESD tolerance is rated for Human Body Model, IEC 61000-4-2, and ISO 10605. The ISO 10605 and IEC 61000-4-2 standards specify ESD tolerance for electronic systems. The serial outputs are rated for ISO 10605 ESD protection and IEC 61000-4-2 ESD protection. All pins are tested for the Human Body Model. The Human Body Model discharge components are CS = 100pF and RD = 1.5kΩ (Figure 26). The IEC 61000-4-2 discharge components are CS = 150pF and RD = 330Ω (Figure 27). The ISO 10605 discharge components are CS = 330pF and RD = 2kΩ (Figure 28).

**Compatibility with Other GMSL Devices**

The device is designed to pair with the MAX96705–MAX96711 family of devices, but interoperates with any GMSL device. See Table 10 for operating limitations.

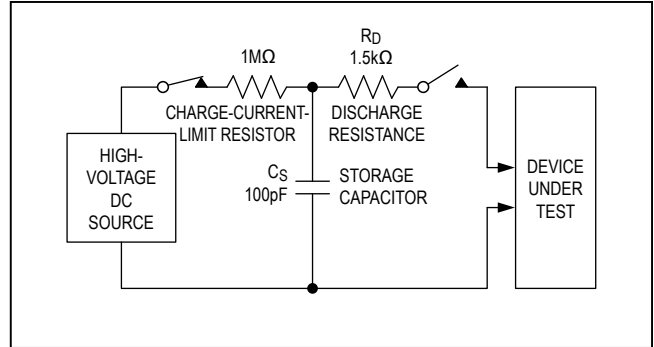

Figure 26. Human Body Model ESD Test Circuit

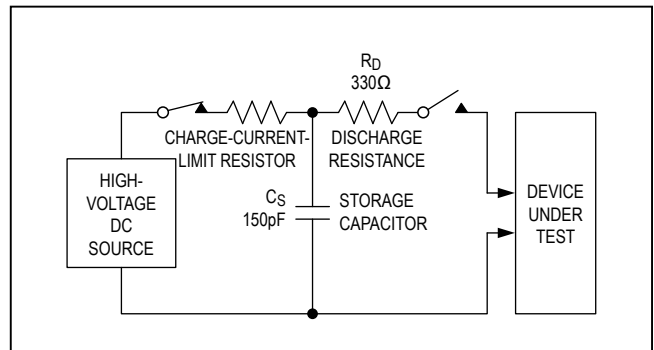

Figure 27. IEC 61000-4-2 Contact Discharge ESD Test Circuit

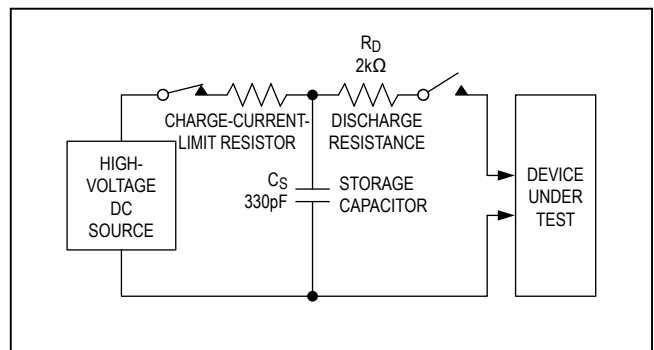

Figure 28. ISO 10605 Contact Discharge ESD Test Circuit

**Table 10. Feature Compatibility**

DESERIALIZER FEATURE	GMSL SERIALIZER
HSYNC/VSYNC encoding	If feature not supported in the serializer, turn off in the deserializer.
I <sup>2</sup> C-to-I <sup>2</sup> C	If feature not supported in the serializer, use UART-to-I <sup>2</sup> C or UART-to-UART.
Packet control channel	If feature not supported in the serializer, use Legacy control channel.
CRC error detection	If feature not supported in the serializer, turn off in the deserializer.
Double input	If feature not supported in the serializer, data is output as a single word at half the input frequency. Use Crossbar switch to correct input mapping.
Coax	If feature not supported in the serializer, connect unused serial input through 200nF and 50Ω in series to AVDD, and set the reverse control-channel amplitude to 100mV.
I <sup>2</sup> S encoding	If supported in the serializer, disable I <sup>2</sup> S in the serializer
High-bandwidth mode	If feature not supported in the serializer, turn off in the deserializer.
High-immunity mode	If feature not supported in the serializer, turn off in the deserializer.

## Device Configuration and Component Selection

### Internal Input Pulldowns

The control and configuration inputs include a pulldown resistor to GND. External pulldown resistors are not needed.

### Multifunction Inputs

The device has several inputs/outputs that function both as a parallel input/output and as a configuration pin. On power-up, or when reverting from a power-down state, the pins act as configuration inputs. After latching the input state, the configuration inputs become parallel digital input/outputs. Connect a configuration input through a 30kΩ resistor to IOVDD to set a high level. Leave the configuration input open to set a low level.

### I<sup>2</sup>C/UART Pullup Resistors

The I<sup>2</sup>C and UART open-drain lines require a pullup resistor to provide a logic-high level. There are tradeoffs between power dissipation and speed, and a compromise may be required when choosing pullup resistor values. Every device connected to the bus introduces some capacitance even when the device is not in operation. I<sup>2</sup>C specifies 300ns rise times (30% to 70%) for fast mode, which is defined for data rates up to 400kbps. See the I<sup>2</sup>C specifications in the I<sup>2</sup>C/UART Port Timing section in the [AC Electrical Characteristics](#) table for details. To meet the fast-mode rise-time requirement, choose the pullup resistors so that rise time  $t_R = 0.85 \times R_{PULLUP} \times C_{BUS} < 300\text{ns}$ . The waveforms are not recognized if the transition time becomes too slow. GMSL supports I<sup>2</sup>C/UART rates up to 1Mbps (UART-to-I<sup>2</sup>C mode) and 400kbps (I<sup>2</sup>C-to-I<sup>2</sup>C mode).

### AC-Coupling Capacitors

Voltage droop and the digital sum variation (DSV) of transmitted symbols cause signal transitions to start from different voltage levels. Because the transition time is fixed, starting the signal transition from different voltage levels causes timing jitter. The time constant for an AC-coupled link needs to be chosen to reduce droop and jitter to an acceptable level. The RC network for an AC-coupled link consists of the CML/coax receiver termination resistor ( $R_{TR}$ ), the CML/coax driver termination resistor ( $R_{TD}$ ), and the series AC-coupling capacitors (C). The RC time constant for four equal-value series capacitors is  $(C \times (R_{TD} + R_{TR}))/4$ .  $R_{TD}$  and  $R_{TR}$  are required to match the transmission line impedance (usually 100Ω differential, 50Ω single-ended). This leaves the capacitor selection to change the system time constant. Use 0.22μF or larger high-frequency surface-mount ceramic capacitors, with sufficient voltage rating to withstand a short to battery, to pass the lower-speed reverse control-channel signal. Use capacitors with a case size less than 3.2mm x 1.6mm to have lower parasitic effects to the high-speed signal.

### Cables and Connectors

Interconnect for CML typically has a differential impedance of 100Ω. Use cables and connectors that have matched differential impedance to minimize impedance discontinuities. Coax cables typically have a characteristic impedance of 50Ω (contact the factory for 75Ω operation). [Table 11](#) lists the suggested cables and connectors used in the GMSL link.

**Table 11. Suggested Connectors and Cables for GMSL**

VENDOR	CONNECTOR	CABLE	TYPE
Rosenberger	59S2AX-400A5-Y	Dacar 302	Coax
Rosenberger	D4S10A-40ML5-Z	Dacar 535-2	STP
Nissei	GT11L-2S	F-2WME AWG28	STP
JAE	MX38-FF	A-BW-Lxxxxx	STP

**PRBS**

The serializer includes a PRBS pattern generator that works with bit-error verification in the deserializer. To run the PRBS test, set PRBSEN = 1 (0x04, D5) in the deserializer, then in the serializer. To exit the PRBS test, set PRBSEN = 0 (0x04, D5) in the serializer. The deserializer automatically ends PRBS checking and sets the PRBS\_OK bit high. Note that during PRBS mode, the remote control channel is not available except to exit PRBS mode if I2C\_LOC\_ACK=1; otherwise, the remote control channel is not available at all.

To run the PRBS with a 3Gbps SerDes, or when HIBW = 1, first set the PRBS\_TYPE bit = 0 in the MAX967XX. Then set PRBSEN = 1 (0x04, D5) in the serializer, then in the deserializer. To exit the PRBS test, set PRBSEN = 0 (0x04, D5) in the deserializer, then in the serializer.

During PRBS test, ERRB function changes to reflect PRBS errors only. ERRB goes low when any PRBS errors occur. ERRB goes high when the PRBS error counter is reset when PRBS\_ERR is read. Normal ERRB function resumes when exiting the PRBS test.

**GPI/GPO**

GPO on the serializer follows GPI transitions on the deserializer. By default, the GPI-to-GPO delay is 0.35ms (max). Keep the time between GPI transitions to a minimum 0.35ms. GPI\_IN the deserializer stores the GPI input state. GPO is low after power-up. The  $\mu$ C can set GPO by writing to the SET\_GPO register bit. Do not send a logic-low value on the deserializer RX/SDA input (UART mode) longer than 100 $\mu$ s in either base or bypass mode to ensure proper GPO/GPI functionality.

**Fast Detection of Loss-of-Lock**

A measure of link quality is the recovery time from loss of synchronization. The host can be quickly notified of loss-of-lock by connecting the deserializer's LOCK output to the GPI input (when PKTCC\_EN = 0). If other sources use the GPI input, such as a touch-screen controller, the  $\mu$ C can implement a routine to distinguish between interrupts from loss-of-sync and normal interrupts. Reverse control-channel communication does not require an active forward link to operate and accurately tracks the LOCK

status of the GMSL link. LOCK asserts for video link only and not for the configuration link.

**Providing a Frame Sync (Camera Applications)**

The GPI and GPO provide a simple solution for camera applications that require a frame sync signal from the ECU (e.g., surround-view systems). Connect the ECU frame sync signal to the GPI input and connect the GPO output to the camera-frame sync input. GPI/GPO have a typical delay of 275 $\mu$ s in legacy mode and 21 $\mu$ s in packet mode (with 5-bit CRC). Skew between multiple GPI/GPO channels is 115 $\mu$ s (max) in legacy mode and 21 $\mu$ s (max) in packet mode. If a lower-skew signal is required in legacy mode, connect the camera's frame-sync input to one of the serializer's GPIOs and use an I<sup>2</sup>C broadcast write command to change the GPIO output state. This has a maximum skew of 1.5 $\mu$ s, independent from the used I<sup>2</sup>C bit rate. In packet-based control-channel mode, set GPI\_COMP\_EN = 1 in both the serializer and the deserializer to turn on GPI/GPO compensation. This reduces the device-to-device skew to 0.35 $\mu$ s.

**Entering/Exiting Sleep Mode**

The procedure for entering and exiting sleep mode depends on the location of the microcontroller, and the type of control-channel interface used. If wake-up from a remote-side (serializer-side) microcontroller is not needed or desired, set the DIS\_RWAKE bit = 1 to shut down remote wake-up for further power savings.

**Legacy Control Channel**

When  $\mu$ C is on the deserializer side, first put the serializer to sleep, or disable serialization. Next, set SLEEP = 1 in deserializer. The device sleeps after 8ms. To wake up the device, send an arbitrary control-channel command to the deserializer (the device will not send an acknowledge), wait for 5ms for the chip to power up and then set SLEEP = 0 to make the wake-up permanent.

When  $\mu$ C is on the serializer side, set SLEEP = 1 in deserializer. Next, disable serialization. The device sleeps after 8ms. To wake up the deserializer, reenables serialization. The deserializer wakes up and clears its SLEEP bit when it locks to the serializer.

**Packet-Based Control Channel**

When  $\mu\text{C}$  is on the deserializer side, first put the serializer to sleep, or disable serialization. Next, set SLEEP = 1 in deserializer. The device sleeps after 8ms. To wake up the deserializer, send an arbitrary control-channel command to deserializer (the device will not send an acknowledge), wait for 5ms for the chip to power up, then set SLEEP = 0 to make the wake-up permanent.

When  $\mu\text{C}$  is on the serializer side, Set SLEEP = 1 in deserializer. Next, disable serialization in the serializer. The device sleeps after 8ms. To wake up the deserializer, reenale serialization. The deserializer wakes up and clear its SLEEP bit when it locks to the serializer.

**Typical Application Circuit**

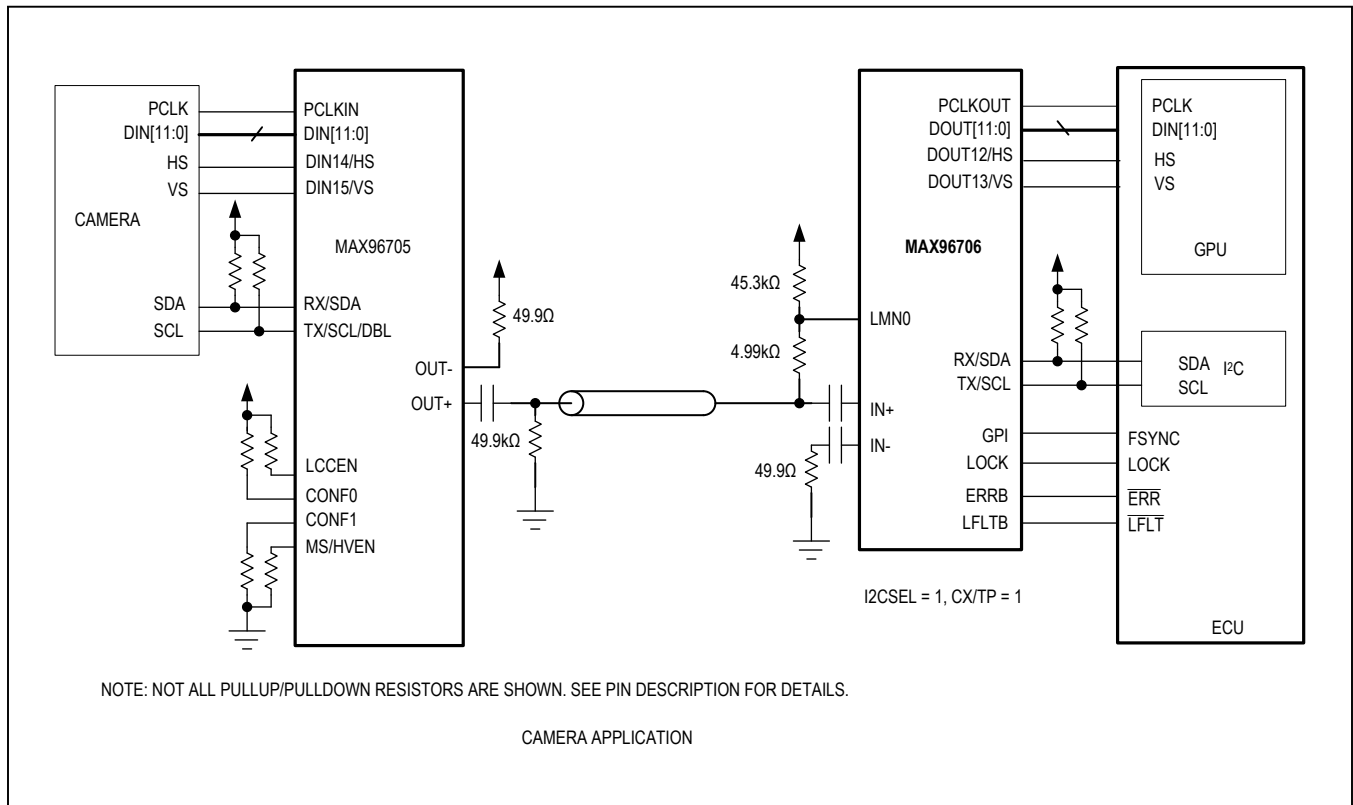

**Ordering Information**

PART NUMBER	TEMP RANGE	PIN-PACKAGE
MAX96706GTJ+	-40°C to +115°C	32 TQFN-EP*
MAX96706GTJ+T	-40°C to +115°C	32 TQFN-EP*
MAX96706GTJ/V+	-40°C to +115°C	32 TQFN-EP*
MAX96706GTJ/V+T	-40°C to +115°C	32 TQFN-EP*
MAX96706GTJ/VY+T	-40°C to +115°C	32 SWTQFN-EP*

*/V denotes an automotive qualified product.*  
*+Denotes a lead(Pb)-free/RoHS-compliant package.*  
*\*EP = Exposed pad.*  
*T = Tape and reel.*

## Revision History

REVISION NUMBER	REVISION DATE	DESCRIPTION	PAGES CHANGED
0	4/16	Initial release	—
1	3/17	Various updates, beginning with <i>Absolute Maximum Ratings</i>	6, 30–34, 40–48, 67, 68, 70, 71
2	11/18	Added SWTQFN package information to <i>General Description, Absolute Maximum Ratings, Package Thermal Characteristics, and Ordering Information</i>	1, 6, 72

For pricing, delivery, and ordering information, please contact Maxim Direct at 1-888-629-4642, or visit Maxim Integrated's website at [www.maximintegrated.com](http://www.maximintegrated.com).

Maxim Integrated cannot assume responsibility for use of any circuitry other than circuitry entirely embodied in a Maxim Integrated product. No circuit patent licenses are implied. Maxim Integrated reserves the right to change the circuitry and specifications without notice at any time. The parametric values (min and max limits) shown in the Electrical Characteristics table are guaranteed. Other parametric values quoted in this data sheet are provided for guidance.

## Looking for pricing, stock, or lifecycle information?

Click below to explore more details on WIN SOURCE:

- ⊖ [View MAX96706GTJ/V+T on WIN SOURCE](#)
- ⊖ [Maxim Integrated Information](#)

## Optimize Your Supply Chain with WIN SOURCE Solutions

- ✓ Global Sourcing Solution
- ✓ Obsolete Management
- ✓ Cost Control Management
- ✓ Shortage Management
- ✓ Alternative Solution
- ✓ Excess Inventory Management