



# THE DATASHEET OF RT8884BGQW



## Multi-Phase PWM Controller for CPU Core Power Supply

### General Description

The RT8884B is a 4/3/2/1 multi-phase synchronous Buck controller designed to meet Intel VR12.5 compatible CPU specification with a serial VID control interface. The RT8884B adopts G-NAVP™ (Green Native AVP) which is Richtek's proprietary topology derived from finite DC gain of EA amplifier with current mode control, making it easy to set the droop to meet all Intel CPU requirements of AVP (Adaptive Voltage Positioning). Based on the G-NAVP™ topology, the RT8884B also features a quick response mechanism for optimized AVP performance during load transient. The RT8884B supports mode transition function with various operating states. A Serial VID (SVID) interface is built in the RT8884B to communicate with Intel VR12.5 compliant CPU. The RT8884B supports VID on-the-fly function with three different slew rates : Fast, Slow and Decay. By utilizing the G-NAVP™ topology, the operating frequency of the RT8884B varies with VID, load current and input voltage to further enhance the efficiency even in CCM. Besides G-NAVP™, the CCRCOT (Constant Current Ripple Constant On Time) technology provides superior output voltage ripple over the entire input/output range.

### Features

- Intel VR12.5 Serial VID Interface Compatible
- 4/3/2/1 Phase PWM Controller
- G-NAVP™ Topology
- 0.5% DAC Accuracy
- Differential Remote Voltage Sensing
- Built-in ADC for Platform Programming
- Accurate Current Balance
- System Thermal Compensated AVP
- Diode Emulation Mode at Light Load Condition for Single Phase Operation
- Fast Transient Response
- VR Ready Indicator
- Thermal Throttling
- Current Monitor Output
- OVP, UVP, OCP, NVP, UVLO
- External No-Load Offset Setting
- DVID Enhancement
- Small 32-Lead WQFN Package
- RoHS Compliant and Halogen Free

### Applications

- VR12.5 Intel Core Power Supply
- Notebook/Desktop Computer/Servers Multi-phase CPU Core Power Supply
- AVP Step-Down Converter

### Simplified Application Circuit

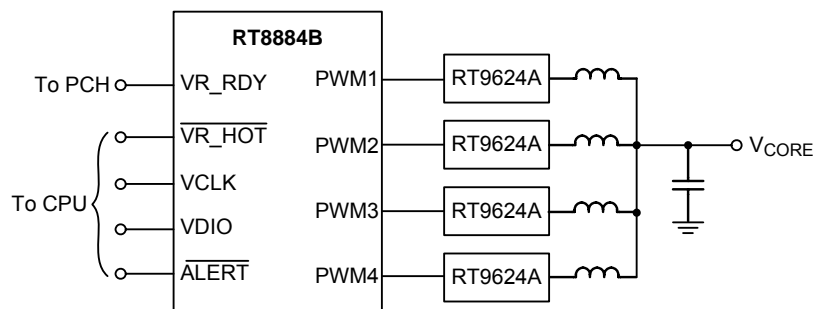

## Ordering Information

RT8884B □ □

- └ Package Type  
QW : WQFN-32L 4x4 (W-Type)
- └ Lead Plating System  
G : Green (Halogen Free and Pb Free)

## Marking Information

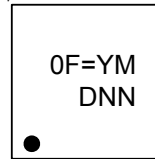

0F= : Product Code  
YMDNN : Date Code

Note :

Richtek products are :

- ▶ RoHS compliant and compatible with the current requirements of IPC/JEDEC J-STD-020.
- ▶ Suitable for use in SnPb or Pb-free soldering processes.

## Pin Configurations

(TOP VIEW)

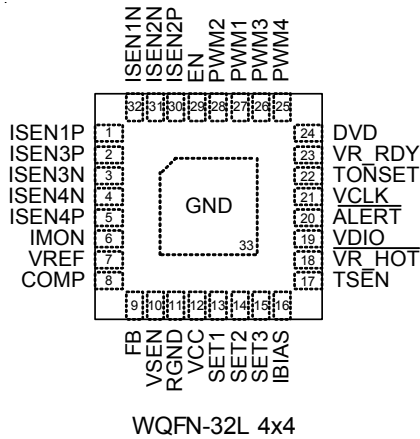

**Functional Pin Description**

Pin No.	Pin Name	Pin Function
1, 30, 2, 5	ISEN [1:4] P	Positive Current Sense Inputs of Channel 1, 2, 3 and 4.
32, 31, 3, 4	ISEN [1:4] N	Negative Current Sense Inputs of Channel 1, 2, 3 and 4.
6	IMON	CPU CORE Current Monitor Output. This pin outputs a voltage proportional to the output current.
7	VREF	Fixed 0.6V Output Reference Voltage. This voltage is only used to offset the output voltage of IMON pin. Connect a 0.47 $\mu$ F decoupling capacitor between this pin and GND.
8	COMP	CORE VR Compensation. This pin is an error amplifier output pin.
9	FB	Negative Input of the Error Amplifier. This pin is for output voltage feedback to controller.
10	VSEN	VR Voltage Sense Input. This pin is connected to the terminal of VR output voltage.
11	RGND	Return Ground for VR. This pin is the negative node of the differential remote voltage sensing.
12	VCC	Controller Power Supply. Connect this pin to 5V and place a minimum 2.2 $\mu$ F decoupling capacitor. The decoupling capacitor should be placed to this pin as close as possible.
13	SET1	1 <sup>st</sup> Platform Setting. Platform can use this pin to set DVID time, RSET, DVID width and OCS.
14	SET2	2 <sup>nd</sup> Platform Setting. Platform can use this pin to set ICCMAX, QRTH and QRSET.
15	SET3	3 <sup>rd</sup> Platform Setting. Platform can use this to set output offset voltage.
16	IBIAS	Internal Bias Current Setting. Connect a 100k $\Omega$ resistor from this pin to GND for setting the internal current. Don't connect a bypass capacitor from this pin to GND.
17	TSEN	Thermal Sense Input for CORE VR.
18	$\overline{\text{VR\_HOT}}$	Thermal Monitor Output. (Active low).
19	VDIO	VR and CPU Data Transmission Interface.
20	$\overline{\text{ALERT}}$	SVID Alert. (Active low)
21	VCLK	Synchronous Clock from the CPU.
22	TONSET	On-time Setting. An on-time setting resistor is connected from this pin to input voltage.
23	VR_RDY	VR Ready Indicator.
24	DVD	Divided Input Voltage Detection of CORE VR. Connect this pin to a voltage divider from input voltage of power stage to detect input voltage.
27, 28, 26, 25	PWM [1:4]	PWM Outputs for Channel 1, 2, 3 and 4.
29	EN	VR Enable.
33 (Exposed Pad)	GND	Ground. The exposed pad must be soldered to a large PCB and connected to GND for maximum power dissipation.

Function Block Diagram

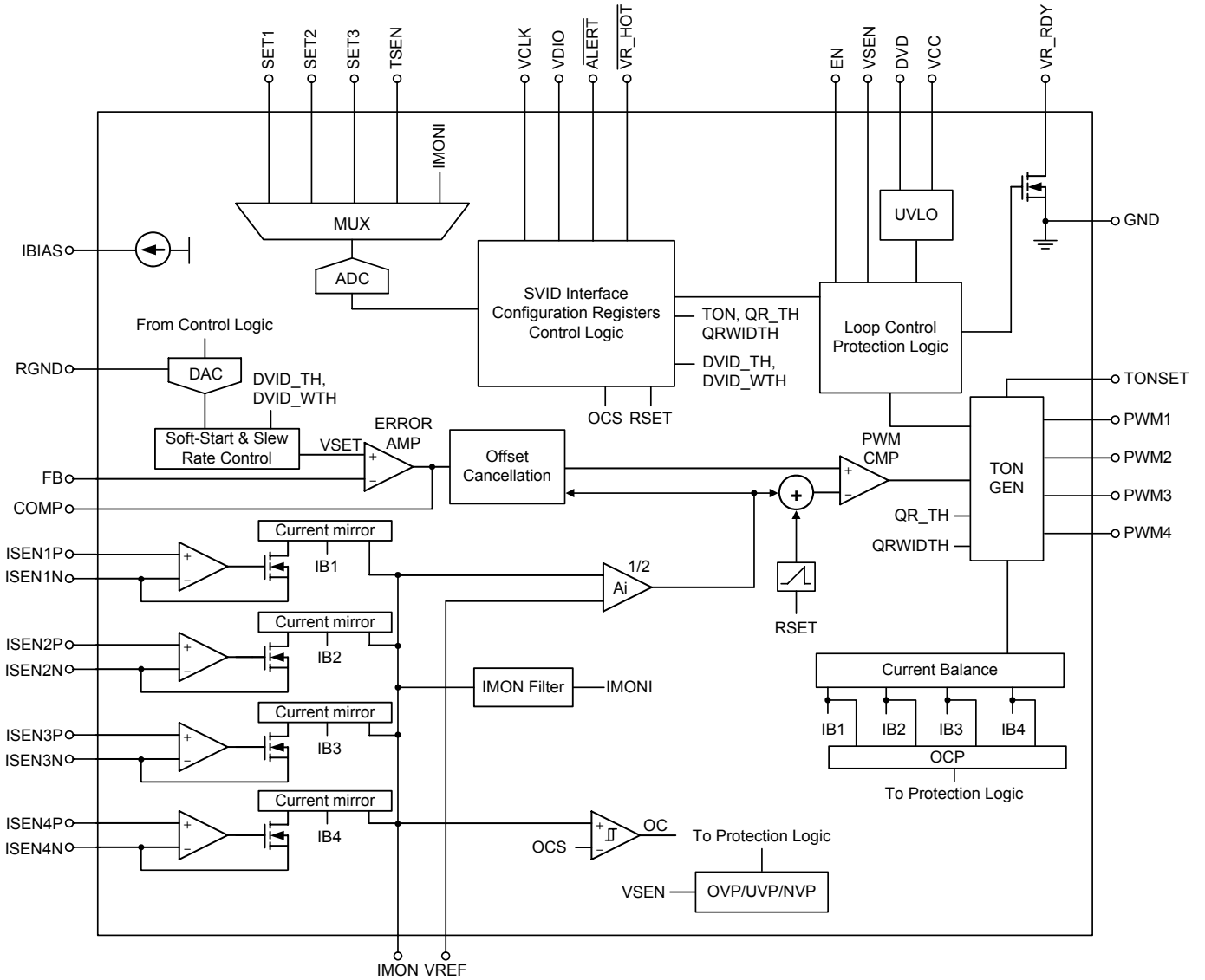

## Operation

The RT8884B adopts G-NAVP™ (Green Native AVP) which is Richtek's proprietary topology derived from finite DC gain of EA amplifier with current mode control, making it easy to set the droop to meet all Intel CPU requirements of AVP (Adaptive Voltage Positioning).

The RT8884B adopts the G-NAVP™ controller, which is one type of current mode constant on-time control with DC offset cancellation. The approach can not only improve DC offset problem for increasing system accuracy but also provide fast transient response. For the RT8884B, when current feedback signal reaches COMP signal to generate an on-time width to achieve PWM modulation.

### TON GEN

Generate the PWM1 to PWM4 sequentially according to the phase control signal from the Loop Control Protection Logic.

### SVID Interface/Configuration Registers/Control Logic

The interface that receives the SVID signal from CPU and sends the relative signals to Loop Control Protection Logic to execute the action by CPU.

The registers save the pin setting data from ADC output.

The Control Logic controls the ADC timing and generates the digital code of the VID that is relative to VSEN.

### Loop Control Protection Logic

It controls the power on sequence, the protection behavior, and the operational phase number.

### Current Balance

Each phase current sense signal is sent to the current balance circuit which adjusts the on-time of each phase to optimize current sharing.

### Offset Cancellation

Cancel the current/voltage ripple issue to get the accurate VSEN.

### UVLO

Detect the DVD and VCC voltage and issue POR signal as they are high enough.

### DAC

Generate an analog signal according to the digital code generated by Control Logic.

### Soft-Start & Slew Rate Control

Control the Dynamic VID slew rate of VSET according to the SetVID fast or SetVID slow.

Table 1. VR12.5 VID Code Table

VID7	VID6	VID5	VID4	VID3	VID2	VID1	VID0	HEX	Voltage (V)
0	0	0	0	0	0	0	0	00	0.000
0	0	0	0	0	0	0	1	01	0.500
0	0	0	0	0	0	1	0	02	0.510
0	0	0	0	0	0	1	1	03	0.520
0	0	0	0	0	1	0	0	04	0.530
0	0	0	0	0	1	0	1	05	0.540
0	0	0	0	0	1	1	0	06	0.550
0	0	0	0	0	1	1	1	07	0.560
0	0	0	0	1	0	0	0	08	0.570
0	0	0	0	1	0	0	1	09	0.580
0	0	0	0	1	0	1	0	0A	0.590
0	0	0	0	1	0	1	1	0B	0.600
0	0	0	0	1	1	0	0	0C	0.610
0	0	0	0	1	1	0	1	0D	0.620
0	0	0	0	1	1	1	0	0E	0.630
0	0	0	0	1	1	1	1	0F	0.640
0	0	0	1	0	0	0	0	10	0.650
0	0	0	1	0	0	0	1	11	0.660
0	0	0	1	0	0	1	0	12	0.670
0	0	0	1	0	0	1	1	13	0.680
0	0	0	1	0	1	0	0	14	0.690
0	0	0	1	0	1	0	1	15	0.700
0	0	0	1	0	1	1	0	16	0.710
0	0	0	1	0	1	1	1	17	0.720
0	0	0	1	1	0	0	0	18	0.730
0	0	0	1	1	0	0	1	19	0.740
0	0	0	1	1	0	1	0	1A	0.750
0	0	0	1	1	0	1	1	1B	0.760
0	0	0	1	1	1	0	0	1C	0.770
0	0	0	1	1	1	0	1	1D	0.780
0	0	0	1	1	1	1	0	1E	0.790
0	0	0	1	1	1	1	1	1F	0.800
0	0	1	0	0	0	0	0	20	0.810
0	0	1	0	0	0	0	1	21	0.820
0	0	1	0	0	0	1	0	22	0.830
0	0	1	0	0	0	1	1	23	0.840
0	0	1	0	0	1	0	0	24	0.850
0	0	1	0	0	1	0	1	25	0.860
0	0	1	0	0	1	1	0	26	0.870
0	0	1	0	0	1	1	1	27	0.880

VID7	VID6	VID5	VID4	VID3	VID2	VID1	VID0	HEX	Voltage (V)
0	0	1	0	1	0	0	0	28	0.890
0	0	1	0	1	0	0	1	29	0.900
0	0	1	0	1	0	1	0	2A	0.910
0	0	1	0	1	0	1	1	2B	0.920
0	0	1	0	1	1	0	0	2C	0.930
0	0	1	0	1	1	0	1	2D	0.940
0	0	1	0	1	1	1	0	2E	0.950
0	0	1	0	1	1	1	1	2F	0.960
0	0	1	1	0	0	0	0	30	0.970
0	0	1	1	0	0	0	1	31	0.980
0	0	1	1	0	0	1	0	32	0.990
0	0	1	1	0	0	1	1	33	1.000
0	0	1	1	0	1	0	0	34	1.010
0	0	1	1	0	1	0	1	35	1.020
0	0	1	1	0	1	1	0	36	1.030
0	0	1	1	0	1	1	1	37	1.040
0	0	1	1	1	0	0	0	38	1.050
0	0	1	1	1	0	0	1	39	1.060
0	0	1	1	1	0	1	0	3A	1.070
0	0	1	1	1	0	1	1	3B	1.080
0	0	1	1	1	1	0	0	3C	1.090
0	0	1	1	1	1	0	1	3D	1.100
0	0	1	1	1	1	1	0	3E	1.110
0	0	1	1	1	1	1	1	3F	1.120
0	1	0	0	0	0	0	0	40	1.130
0	1	0	0	0	0	0	1	41	1.140
0	1	0	0	0	0	1	0	42	1.150
0	1	0	0	0	0	1	1	43	1.160
0	1	0	0	0	1	0	0	44	1.170
0	1	0	0	0	1	0	1	45	1.180
0	1	0	0	0	1	1	0	46	1.190
0	1	0	0	0	1	1	1	47	1.200
0	1	0	0	1	0	0	0	48	1.210
0	1	0	0	1	0	0	1	49	1.220
0	1	0	0	1	0	1	0	4A	1.230
0	1	0	0	1	0	1	1	4B	1.240
0	1	0	0	1	1	0	0	4C	1.250
0	1	0	0	1	1	0	1	4D	1.260
0	1	0	0	1	1	1	0	4E	1.270
0	1	0	0	1	1	1	1	4F	1.280

VID7	VID6	VID5	VID4	VID3	VID2	VID1	VID0	HEX	Voltage (V)
0	1	0	1	0	0	0	0	50	1.290
0	1	0	1	0	0	0	1	51	1.300
0	1	0	1	0	0	1	0	52	1.310
0	1	0	1	0	0	1	1	53	1.320
0	1	0	1	0	1	0	0	54	1.330
0	1	0	1	0	1	0	1	55	1.340
0	1	0	1	0	1	1	0	56	1.350
0	1	0	1	0	1	1	1	57	1.360
0	1	0	1	1	0	0	0	58	1.370
0	1	0	1	1	0	0	1	59	1.380
0	1	0	1	1	0	1	0	5A	1.390
0	1	0	1	1	0	1	1	5B	1.400
0	1	0	1	1	1	0	0	5C	1.410
0	1	0	1	1	1	0	1	5D	1.420
0	1	0	1	1	1	1	0	5E	1.430
0	1	0	1	1	1	1	1	5F	1.440
0	1	1	0	0	0	0	0	60	1.450
0	1	1	0	0	0	0	1	61	1.460
0	1	1	0	0	0	1	0	62	1.470
0	1	1	0	0	0	1	1	63	1.480
0	1	1	0	0	1	0	0	64	1.490
0	1	1	0	0	1	0	1	65	1.500
0	1	1	0	0	1	1	0	66	1.510
0	1	1	0	0	1	1	1	67	1.520
0	1	1	0	1	0	0	0	68	1.530
0	1	1	0	1	0	0	1	69	1.540
0	1	1	0	1	0	1	0	6A	1.550
0	1	1	0	1	0	1	1	6B	1.560
0	1	1	0	1	1	0	0	6C	1.570
0	1	1	0	1	1	0	1	6D	1.580
0	1	1	0	1	1	1	0	6E	1.590
0	1	1	0	1	1	1	1	6F	1.600
0	1	1	1	0	0	0	0	70	1.610
0	1	1	1	0	0	0	1	71	1.620
0	1	1	1	0	0	1	0	72	1.630
0	1	1	1	0	0	1	1	73	1.640
0	1	1	1	0	1	0	0	74	1.650
0	1	1	1	0	1	0	1	75	1.660
0	1	1	1	0	1	1	0	76	1.670
0	1	1	1	0	1	1	1	77	1.680

VID7	VID6	VID5	VID4	VID3	VID2	VID1	VID0	HEX	Voltage (V)
0	1	1	1	1	0	0	0	78	1.690
0	1	1	1	1	0	0	1	79	1.700
0	1	1	1	1	0	1	0	7A	1.710
0	1	1	1	1	0	1	1	7B	1.720
0	1	1	1	1	1	0	0	7C	1.730
0	1	1	1	1	1	0	1	7D	1.740
0	1	1	1	1	1	1	0	7E	1.750
0	1	1	1	1	1	1	1	7F	1.760
1	0	0	0	0	0	0	0	80	1.770
1	0	0	0	0	0	0	1	81	1.780
1	0	0	0	0	0	1	0	82	1.790
1	0	0	0	0	0	1	1	83	1.800
1	0	0	0	0	1	0	0	84	1.810
1	0	0	0	0	1	0	1	85	1.820
1	0	0	0	0	1	1	0	86	1.830
1	0	0	0	0	1	1	1	87	1.840
1	0	0	0	1	0	0	0	88	1.850
1	0	0	0	1	0	0	1	89	1.860
1	0	0	0	1	0	1	0	8A	1.870
1	0	0	0	1	0	1	1	8B	1.880
1	0	0	0	1	1	0	0	8C	1.890
1	0	0	0	1	1	0	1	8D	1.900
1	0	0	0	1	1	1	0	8E	1.910
1	0	0	0	1	1	1	1	8F	1.920
1	0	0	1	0	0	0	0	90	1.930
1	0	0	1	0	0	0	1	91	1.940
1	0	0	1	0	0	1	0	92	1.950
1	0	0	1	0	0	1	1	93	1.960
1	0	0	1	0	1	0	0	94	1.970
1	0	0	1	0	1	0	1	95	1.980
1	0	0	1	0	1	1	0	96	1.990
1	0	0	1	0	1	1	1	97	2.000
1	0	0	1	1	0	0	0	98	2.010
1	0	0	1	1	0	0	1	99	2.020
1	0	0	1	1	0	1	0	9A	2.030
1	0	0	1	1	0	1	1	9B	2.040
1	0	0	1	1	1	0	0	9C	2.050
1	0	0	1	1	1	0	1	9D	2.060
1	0	0	1	1	1	1	0	9E	2.070
1	0	0	1	1	1	1	1	9F	2.080

VID7	VID6	VID5	VID4	VID3	VID2	VID1	VID0	HEX	Voltage (V)
1	0	1	0	0	0	0	0	A0	2.090
1	0	1	0	0	0	0	1	A1	2.100
1	0	1	0	0	0	1	0	A2	2.110
1	0	1	0	0	0	1	1	A3	2.120
1	0	1	0	0	1	0	0	A4	2.130
1	0	1	0	0	1	0	1	A5	2.140
1	0	1	0	0	1	1	0	A6	2.150
1	0	1	0	0	1	1	1	A7	2.160
1	0	1	0	1	0	0	0	A8	2.170
1	0	1	0	1	0	0	1	A9	2.180
1	0	1	0	1	0	1	0	AA	2.190
1	0	1	0	1	0	1	1	AB	2.200
1	0	1	0	1	1	0	0	AC	2.210
1	0	1	0	1	1	0	1	AD	2.220
1	0	1	0	1	1	1	0	AE	2.230
1	0	1	0	1	1	1	1	AF	2.240
1	0	1	1	0	0	0	0	B0	2.250
1	0	1	1	0	0	0	1	B1	2.260
1	0	1	1	0	0	1	0	B2	2.270
1	0	1	1	0	0	1	1	B3	2.280
1	0	1	1	0	1	0	0	B4	2.290
1	0	1	1	0	1	0	1	B5	2.300
1	0	1	1	0	1	1	0	B6	2.310
1	0	1	1	0	1	1	1	B7	2.320
1	0	1	1	1	0	0	0	B8	2.330
1	0	1	1	1	0	0	1	B9	2.340
1	0	1	1	1	0	1	0	BA	2.350
1	0	1	1	1	0	1	1	BB	2.360
1	0	1	1	1	1	0	0	BC	2.370
1	0	1	1	1	1	0	1	BD	2.380
1	0	1	1	1	1	1	0	BE	2.390
1	0	1	1	1	1	1	1	BF	2.400
1	1	0	0	0	0	0	0	C0	2.410
1	1	0	0	0	0	0	1	C1	2.420
1	1	0	0	0	0	1	0	C2	2.430
1	1	0	0	0	0	1	1	C3	2.440
1	1	0	0	0	1	0	0	C4	2.450
1	1	0	0	0	1	0	1	C5	2.460
1	1	0	0	0	1	1	0	C6	2.470
1	1	0	0	0	1	1	1	C7	2.480

VID7	VID6	VID5	VID4	VID3	VID2	VID1	VID0	HEX	Voltage (V)
1	1	0	0	1	0	0	0	C8	2.490
1	1	0	0	1	0	0	1	C9	2.500
1	1	0	0	1	0	1	0	CA	2.510
1	1	0	0	1	0	1	1	CB	2.520
1	1	0	0	1	1	0	0	CC	2.530
1	1	0	0	1	1	0	1	CD	2.540
1	1	0	0	1	1	1	0	CE	2.550
1	1	0	0	1	1	1	1	CF	2.560
1	1	0	1	0	0	0	0	D0	2.570
1	1	0	1	0	0	0	1	D1	2.580
1	1	0	1	0	0	1	0	D2	2.590
1	1	0	1	0	0	1	1	D3	2.600
1	1	0	1	0	1	0	0	D4	2.610
1	1	0	1	0	1	0	1	D5	2.620
1	1	0	1	0	1	1	0	D6	2.630
1	1	0	1	0	1	1	1	D7	2.640
1	1	0	1	1	0	0	0	D8	2.650
1	1	0	1	1	0	0	1	D9	2.660
1	1	0	1	1	0	1	0	DA	2.670
1	1	0	1	1	0	1	1	DB	2.680
1	1	0	1	1	1	0	0	DC	2.690
1	1	0	1	1	1	0	1	DD	2.700
1	1	0	1	1	1	1	0	DE	2.710
1	1	0	1	1	1	1	1	DF	2.720
1	1	1	0	0	0	0	0	E0	2.730
1	1	1	0	0	0	0	1	E1	2.740
1	1	1	0	0	0	1	0	E2	2.750
1	1	1	0	0	0	1	1	E3	2.760
1	1	1	0	0	1	0	0	E4	2.770
1	1	1	0	0	1	0	1	E5	2.780
1	1	1	0	0	1	1	0	E6	2.790
1	1	1	0	0	1	1	1	E7	2.800
1	1	1	0	1	0	0	0	E8	2.810
1	1	1	0	1	0	0	1	E9	2.820
1	1	1	0	1	0	1	0	EA	2.830
1	1	1	0	1	0	1	1	EB	2.840
1	1	1	0	1	1	0	0	EC	2.850
1	1	1	0	1	1	0	1	ED	2.860
1	1	1	0	1	1	1	0	EE	2.870
1	1	1	0	1	1	1	1	EF	2.880

VID7	VID6	VID5	VID4	VID3	VID2	VID1	VID0	HEX	Voltage (V)
1	1	1	1	0	0	0	0	F0	2.890
1	1	1	1	0	0	0	1	F1	2.900
1	1	1	1	0	0	1	0	F2	2.910
1	1	1	1	0	0	1	1	F3	2.920
1	1	1	1	0	1	0	0	F4	2.930
1	1	1	1	0	1	0	1	F5	2.940
1	1	1	1	0	1	1	0	F6	2.950
1	1	1	1	0	1	1	1	F7	2.960
1	1	1	1	1	0	0	0	F8	2.970
1	1	1	1	1	0	0	1	F9	2.980
1	1	1	1	1	0	1	0	FA	2.990
1	1	1	1	1	0	1	1	FB	3.000
1	1	1	1	1	1	0	0	FC	3.010
1	1	1	1	1	1	0	1	FD	3.020
1	1	1	1	1	1	1	0	FE	3.030
1	1	1	1	1	1	1	1	FF	3.040

**Table 2. Standard Serial VID Commands**

Code	Commands	Master Payload Contents	Slave Payload Contents	Description
00h	not supported	N/A	N/A	N/A
01h	SetVID_Fast	VID code	N/A	<ol style="list-style-type: none"> <li>1. Set new target VID code, VR jumps to new VID target with controlled default “fast” slew rate 12.5mV/μs.</li> <li>2. Set VR_Settled when VR reaches target VID voltage.</li> </ol>
02h	SetVID_Slow	VID code	N/A	<ol style="list-style-type: none"> <li>1. Set new target VID code, VR jumps to new VID target with controlled default “slow” slew rate 3.125mV/μs.</li> <li>2. Set VR_Settled when VR reaches target VID voltage.</li> </ol>
03h	SetVID_Decay	VID code	N/A	<ol style="list-style-type: none"> <li>1. Set new target VID code, VR jumps to new VID target, but does not control the slew rate. The output voltage decays at a rate proportional to the load current.</li> <li>2. Low side MOSFET is not allowed to sync current.</li> <li>3. ACK 11b when target higher than current VOUT voltage.</li> <li>4. ACK 10b when target lower than current VOUT voltage.</li> </ol>
04h	SetPS	Byte indicating power states	N/A	<ol style="list-style-type: none"> <li>1. Set power state.</li> <li>2. ACK 11b when not support.</li> <li>3. ACK 10b even slave not change configuration.</li> <li>4. ACK 11b for still running SetVID command.</li> <li>5. VR remains in lower state when receiving SetVID (decay).</li> </ol>
05h	SetRegADR	Pointer of registers in data table	N/A	<ol style="list-style-type: none"> <li>1. Set the pointer of the data register.</li> <li>2. ACK 11b for address outside of support.</li> <li>3. NAK 01b for SetADR (all call).</li> </ol>
06h	SetReg DAT	New data register content	N/A	<ol style="list-style-type: none"> <li>1. Write the contents to the data register.</li> <li>2. NAK 01b for SetReg (all call).</li> </ol>
07h	GetReg		Specified Register Contents	<ol style="list-style-type: none"> <li>1. Slave returns the contents of the specified register as the payload.</li> <li>2. ACK 11b for non support address.</li> <li>3. NAK 01b for GetReg (all call).</li> </ol>
08h to 1Fh	not supported	N/A	N/A	N/A

Table 3. SVID Data and Configuration Register

Index	Register Name	Description	Access	Default
00h	Vendor ID	Vendor ID	RO, Vendor	1Eh
01h	Product ID	Product ID	RO, Vendor	84h
02h	Product Revision	Product Revision	RO, Vendor	00h
05h	Protocol ID	SVID Protocol ID	RO, Vendor	02h
06h	Capability	Bit mapped register, identifies the SVID VR Capabilities and which of the optional telemetry register is supported.	RO, Vendor	81h
10h	Status_1	Data register containing the status of VR.	R-M, W-PWM	00h
11h	Status-2	Data register containing the status of transmission.	R-M, W-PWM	00h
12h	Temperature Zone	Data register showing temperature zone that has been entered.	R-M, W-PWM	00h
15h	IOUT	At PS0 to PS2, IOUT report data from ADC sense IMON voltage. When power state at PS3, the IOUT report data is fixed to 04h.	R-M, W-PWM	00h
1Ch	Status_2_lastread	The register contains a copy of the status_2.	R-M, W-PWM	00h
21h	ICC Max	Data register containing the ICC max the platform supports. Binary format in A IE 64h = 100A.	RO, Platform	7Dh
22h	Temp Max	Data register containing the temperature max the platform supports. Binary format in °C IE 64h = 100°C.	RO, Platform	64h
24h	SR-fast	Data register containing the capability of fast slew rate the platform can sustain. Binary format in mV/μs IE 0Ah = 10 mV/μs.	RO	0Ah
25h	SR-slow	Data register containing the capability of slow slew rate. Binary format in mV/μs IE 02h = 2mV/μs.	RO	02h
30h	VOOUT Max	The register is programmed by master and sets the maximum VID.	RW, Master	B5h
31h	VID Setting	Data register containing currently programmed VID.	RW, Master	00h
32h	Power State	Register containing the current programmed power state.	RW, Master	00h
33h	Offset	Set offset in VID steps.	RW, Master	00h
34h	Multi VR Configuration	Bit mapped data register which configures multiple VRs behavior on the same bus.	RW, Master	00h
35h	Pointer	Scratch pad register for temporary storage of the SetRegADR pointer register.	RW, Master	30h

Notes :

RO = Read Only

RW = Read/Write

R-M = Read by Master

W-PWM = Write by PWM Only

Vendor = Hard Coded by VR Vendor

Platform = Programmed by the Master

PWM = Programmed by the VR Control IC

**Absolute Maximum Ratings** (Note 1)

- VCC to GND ----- -0.3V to 6.5V
- RGND to GND ----- -0.3V to 0.3V
- TONSET to GND ----- -0.3V to 6.5V
- Other Pins ----- -0.3V to (V<sub>CC</sub> + 0.3V)
- Power Dissipation, P<sub>D</sub> @ T<sub>A</sub> = 25°C  
 WQFN-32L 4x4 ----- 3.6W
- Package Thermal Resistance (Note 2)  
 WQFN-32L 4x4, θ<sub>JA</sub> ----- 27.8°C/W  
 WQFN-32L 4x4, θ<sub>JC</sub> ----- 7°C/W
- Junction Temperature ----- 150°C
- Lead Temperature (Soldering, 10 sec.) ----- 260°C
- Storage Temperature Range ----- -65°C to 150°C
- ESD Susceptibility (Note 3)  
 HBM (Human Body Model) ----- 2kV

**Recommended Operating Conditions** (Note 4)

- Supply Voltage, VCC ----- 4.5V to 5.5V
- Junction Temperature Range ----- -40°C to 125°C
- Ambient Temperature Range ----- -40°C to 85°C

**Electrical Characteristics**

(V<sub>CC</sub> = 5V, T<sub>A</sub> = 25°C, unless otherwise specified)

Parameter	Symbol	Test Conditions	Min	Typ	Max	Unit
<b>Supply Input</b>						
Supply Current	I <sub>VCC</sub>	V <sub>EN</sub> = H, Not switching	--	4.1	--	mA
Supply Current at PS3	I <sub>VCC_PS3</sub>	V <sub>EN</sub> = H, Not switching	--	2.7	--	mA
Shutdown Current	I <sub>SHDN</sub>	V <sub>EN</sub> = 0V	--	--	5	μA
<b>Reference and DAC</b>						
DAC Accuracy	V <sub>FB</sub>	V <sub>DAC</sub> = 1.5V – 2.3V	-0.5	0	0.5	% of VID
		V <sub>DAC</sub> = 1V – 1.49V	-8	0	8	mV
		V <sub>DAC</sub> = 0.5V – 0.99V	-10	0	10	
<b>Slew Rate</b>						
Dynamic VID Slew Rate	SR	Set VID slow	2.5	3.125	3.75	mV/μs
		Set VID fast	10	12.5	15	
<b>EA Amplifier</b>						
DC Gain	A <sub>DC</sub>	R <sub>L</sub> = 47kΩ	70	--	--	dB
Gain-Bandwidth Product	G <sub>BW</sub>	C <sub>LOAD</sub> = 5pF	4	5	--	MHz
Slew Rate	S <sub>REA</sub>	C <sub>LOAD</sub> = 10pF (Gain = -4, R <sub>F</sub> = 47kΩ, V <sub>OUT</sub> = 0.5V to -3V)	5	--	--	V/μs

Parameter	Symbol	Test Conditions	Min	Typ	Max	Unit
Output Voltage Range	V <sub>COMP</sub>	R <sub>L</sub> = 47kΩ	0.5	--	3.6	V
Maximum Source/Sink Current	I <sub>OUTEA</sub>	V <sub>COMP</sub> = 2V	--	5	--	mA
<b>Load-Line Current Gain Amplifier</b>						
Input Offset Voltage	V <sub>ILOFS</sub>	V <sub>IMON</sub> = 1V	-5	--	5	mV
Current Gain	A <sub>ILGAIN</sub>	V <sub>IMON</sub> - V <sub>VREF</sub> = 1V V <sub>FEB</sub> = V <sub>COMP</sub> = 1.7V	--	1/2	--	A/A
<b>Current Sensing Amplifier</b>						
Input Offset Voltage	V <sub>OSCS</sub>		-0.8	--	0.8	mV
Impedance at Positive Input	R <sub>ISENXP</sub>		1	--	--	MΩ
Current Mirror Gain	A <sub>MIRROR</sub>	I <sub>IMON</sub> / I <sub>SENxN</sub>	0.97	1	1.03	A/A
<b>TON Setting</b>						
TONSET Pin Voltage	V <sub>TON</sub>	I <sub>RTON</sub> = 80μA, V <sub>DAC</sub> = 1.7V	1.6	1.7	1.8	V
On-Time Setting	T <sub>ON</sub>	I <sub>RTON</sub> = 80μA, V <sub>DAC</sub> = 1.7V	450	500	550	ns
Input Current Range	I <sub>RTON</sub>	V <sub>DAC</sub> = 1.7V	25	--	280	μA
Minimum Off time	T <sub>OFF</sub>	V <sub>DAC</sub> = 1.7V	--	400	--	ns
<b>IBIAS</b>						
IBIAS Pin Voltage	V <sub>IBIAS</sub>	R <sub>IBIAS</sub> = 100kΩ	1.85	2	--	V
<b>OFS Setting</b>						
Impedance	R <sub>OFS</sub>		1	--	--	MΩ
Set OFS Voltage	V <sub>SET3</sub>	Enable OFS function and offset 600mV	1.95	2.4	2.44	V
		Enable OFS function and offset 300mV	1.76	1.8	1.84	
		Enable OFS function and offset 0V	1.16	1.2	1.24	
		Enable OFS function and offset -50mV	1.06	1.1	1.14	
		Enable OFS function and offset -250mV	0.66	0.7	0.74	
		Disable	--	--	0.55	
<b>Protections</b>						
Under Voltage Lockout Threshold	V <sub>UVLO</sub>		4.1	4.3	4.45	V
	ΔV <sub>UVLO</sub>	Falling edge hysteresis	--	200	--	mV
Over Voltage Protection Threshold	V <sub>OV</sub>	VID higher than 1.5V	VID + 300	VID + 350	VID + 400	mV
		VID lower than 1.5V	1800	1850	1900	
Under Voltage Protection Threshold	V <sub>UV</sub>	Respect to VID voltage	-400	-350	-300	mV
Negative Voltage Protection Threshold	V <sub>NV</sub>		-100	-70	--	mV
<b>EN and VR_RDY</b>						
EN Input Voltage	Logic-High	V <sub>IH</sub>	0.7	--	--	V
	Logic-Low	V <sub>IL</sub>	--	--	0.3	
Leakage Current of EN			-1	--	1	μA

Parameter	Symbol	Test Conditions	Min	Typ	Max	Unit	
VR_RDY Delay	T <sub>VR_RDY</sub>	V <sub>SEN</sub> = V <sub>Boot</sub> to VR_RDY High	3	4.5	6	μs	
VR_RDY Pull Low Voltage	V <sub>PGOOD</sub>	I <sub>VR_RDY</sub> = 10mA	--	--	0.13	V	
<b>DVD</b>							
DVD Input	V <sub>DVD</sub>	Detect VIN Voltage	2	--	--	V	
<b>Serial VID and VR_HOT</b>							
VCLK, VDIO Input Voltage	Logic-High	V <sub>IH</sub>	Respect to INTEL Spec. with 50mV hysteresis	0.65	--	--	V
	Logic-Low	V <sub>IL</sub>		--	--	0.45	
Leakage Current of VCLK, VDIO, ALERT and VR_HOT	I <sub>LEAK_IN</sub>		-1	--	1	μA	
VDIO, ALERT and VR_HOT Pull Low Voltage		I <sub>VDIO</sub> = 10mA	--	--	0.13	V	
		I <sub>ALERT</sub> = 10mA					
		I <sub>VR_HOT</sub> = 10mA					
<b>VREF and VBOOT</b>							
VREF Voltage	V <sub>REF</sub>		0.55	0.6	0.65	V	
VBOOT Voltage	V <sub>BOOT</sub>	No Load, set V <sub>BOOT</sub> = 1.7V	1.692	1.7	1.708	V	
<b>ADC</b>							
Digital IMON Set	V <sub>IMON</sub>	V <sub>IMON</sub> - V <sub>IMON_INI</sub> = 1.6V	252	255	258	Decimal	
		V <sub>IMON</sub> - V <sub>IMON_INI</sub> = 0.8V	125	128	131		
		V <sub>IMON</sub> - V <sub>IMON_INI</sub> = 0V	0	0	3		
Update Period of IMON	T <sub>IMON</sub>		320	400	480	μs	
TSEN Threshold for Tmp_Zone [7] transition	V <sub>TSEN</sub>	100°C	--	1.887	--	V	
TSEN Threshold for Tmp_Zone [6] transition	V <sub>TSEN</sub>	97°C	--	1.837	--	V	
TSEN Threshold for Tmp_Zone [5] transition	V <sub>TSEN</sub>	94°C	--	1.784	--	V	
TSEN Threshold for Tmp_Zone [4] transition	V <sub>TSEN</sub>	91°C	--	1.729	--	V	
TSEN Threshold for Tmp_Zone [3] transition	V <sub>TSEN</sub>	88°C	--	1.672	--	V	
TSEN Threshold for Tmp_Zone [2] transition	V <sub>TSEN</sub>	85°C	--	1.612	--	V	
TSEN Threshold for Tmp_Zone [1] transition	V <sub>TSEN</sub>	82°C	--	1.551	--	V	
TSEN Threshold for Tmp_Zone [0] transition	V <sub>TSEN</sub>	75°C	--	1.402	--	V	
Update Period of TSEN	t <sub>TSEN</sub>		40	50	60	μs	
Digital Code of ICCMAX	C <sub>ICCMAX1</sub>	V <sub>ICCMAX</sub> = 0.403V	58	64	70	Decimal	
	C <sub>ICCMAX2</sub>	V <sub>ICCMAX</sub> = 0.806V	122	128	134		
	C <sub>ICCMAX3</sub>	V <sub>ICCMAX</sub> = 1.6V	248	256	260		

Parameter	Symbol	Test Conditions	Min	Typ	Max	Unit
<b>PWM Driving Capability</b>						
PWM Source Resistance	R <sub>PWM_SRC</sub>		--	–	30	Ω
PWM Sink	R <sub>PWM_SNK</sub>		--	–	10	Ω

**Note 1.** Stresses beyond those listed “Absolute Maximum Ratings” may cause permanent damage to the device. These are stress ratings only, and functional operation of the device at these or any other conditions beyond those indicated in the operational sections of the specifications is not implied. Exposure to absolute maximum rating conditions may affect device reliability.

**Note 2.**  $\theta_{JA}$  is measured at  $T_A = 25^\circ\text{C}$  on a high effective thermal conductivity four-layer test board per JEDEC 51-7.  $\theta_{JC}$  is measured at the exposed pad of the package.

**Note 3.** Devices are ESD sensitive. Handling precaution is recommended.

**Note 4.** The device is not guaranteed to function outside its operating conditions.

**Typical Application Circuit**

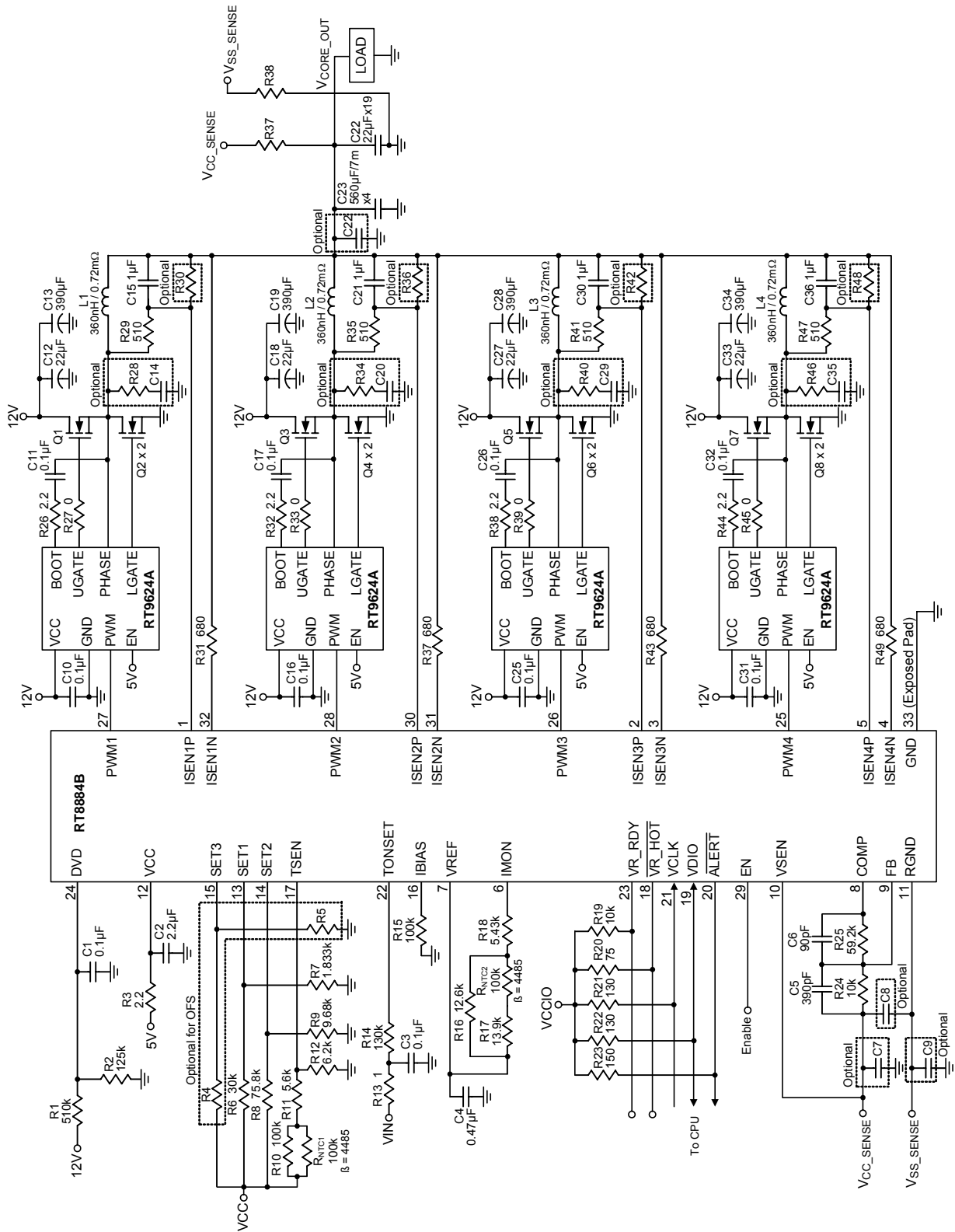

Typical Operating Characteristics

CORE VR Power On from EN

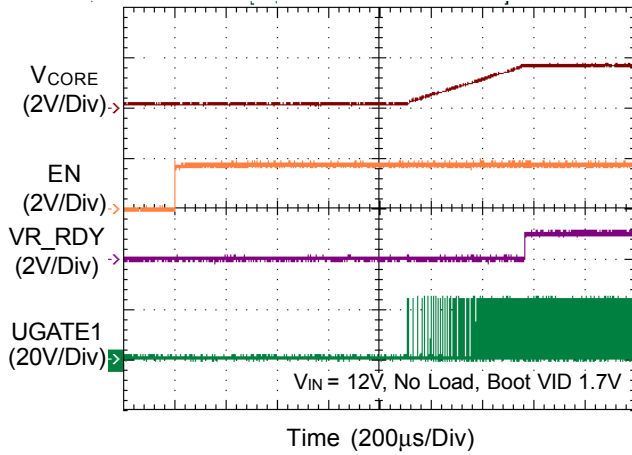

CORE VR Power Off from EN

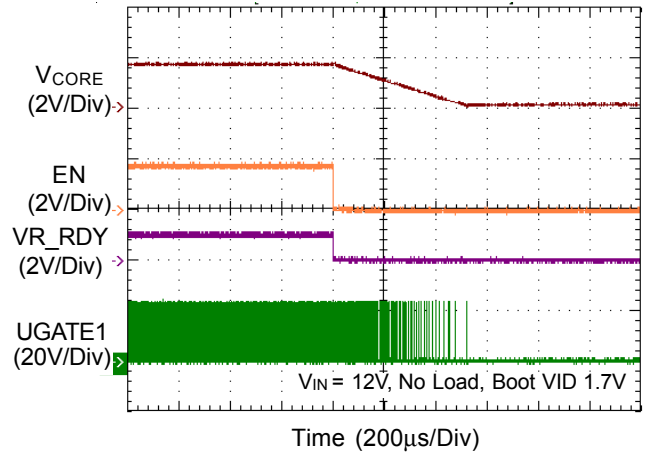

CORE VR OCP

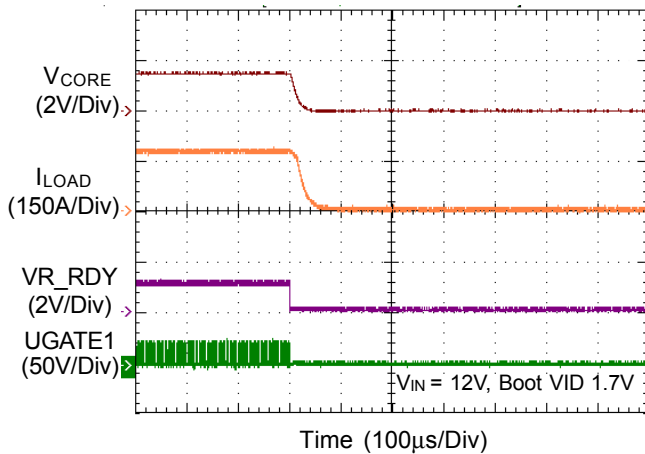

CORE VR OVP

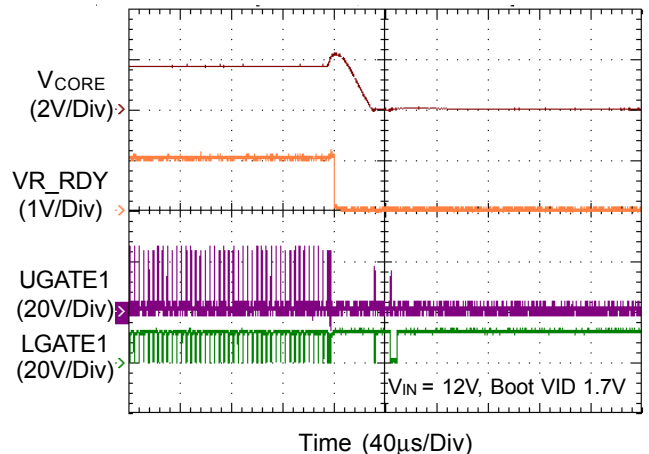

CORE VR Dynamic VID Up

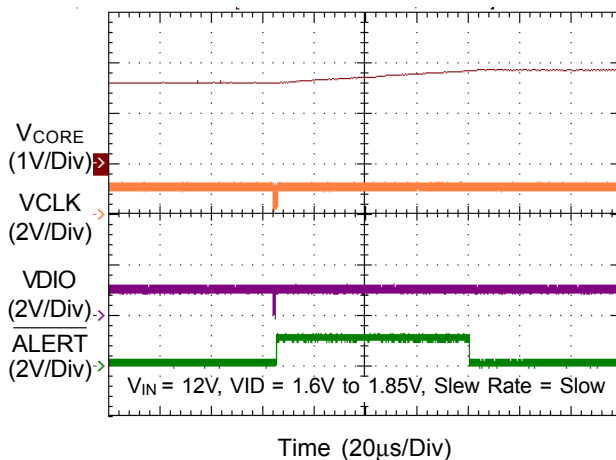

CORE VR Dynamic VID Down

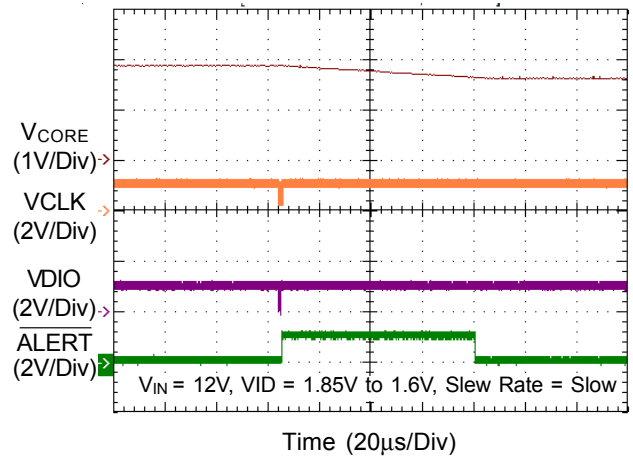

**CORE VR Dynamic VID Up**

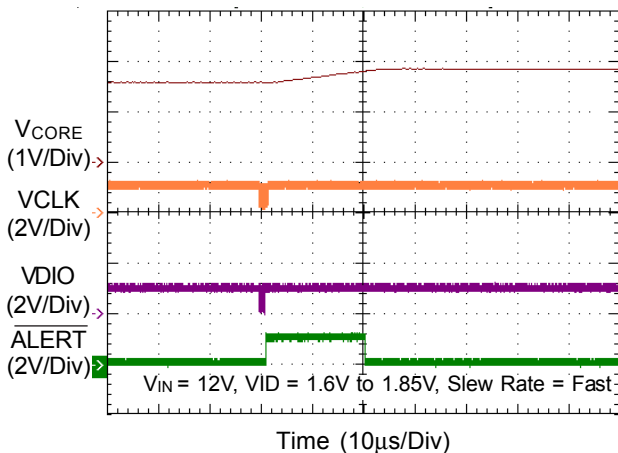

**CORE VR Dynamic VID Down**

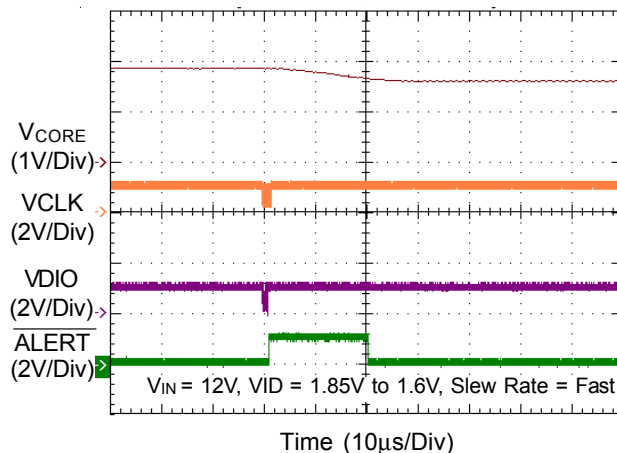

**CORE VR Mode Transient**

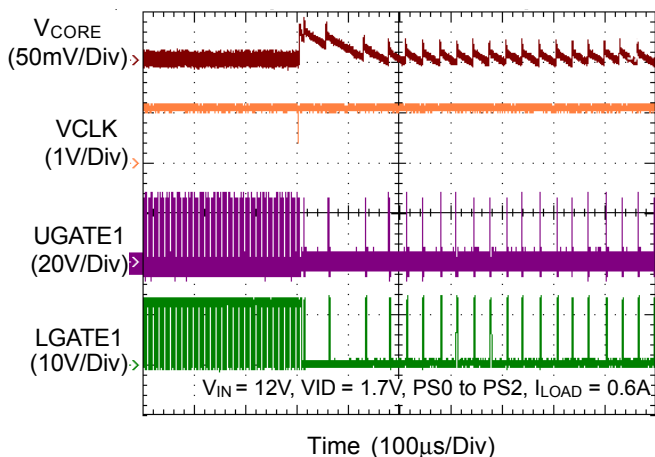

**CORE VR Mode Transient**

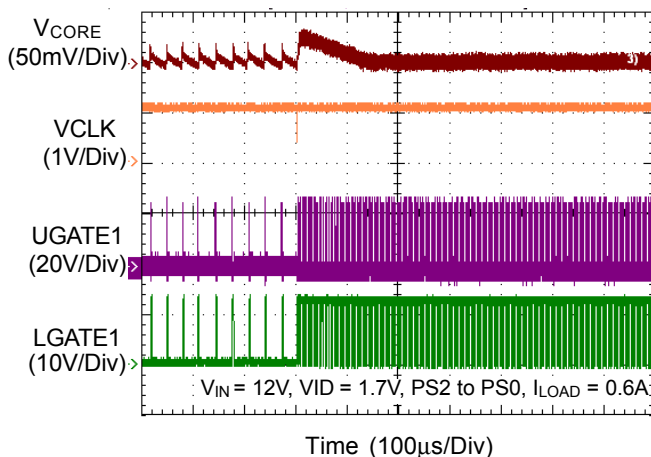

**CORE VR Thermal Monitoring**

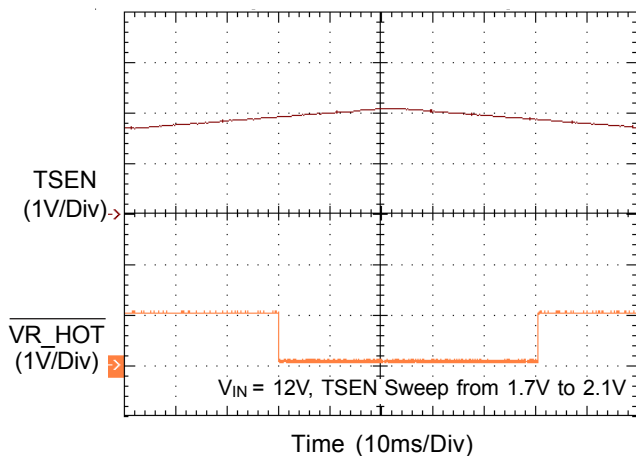

**V<sub>MON</sub> vs. Load Current**

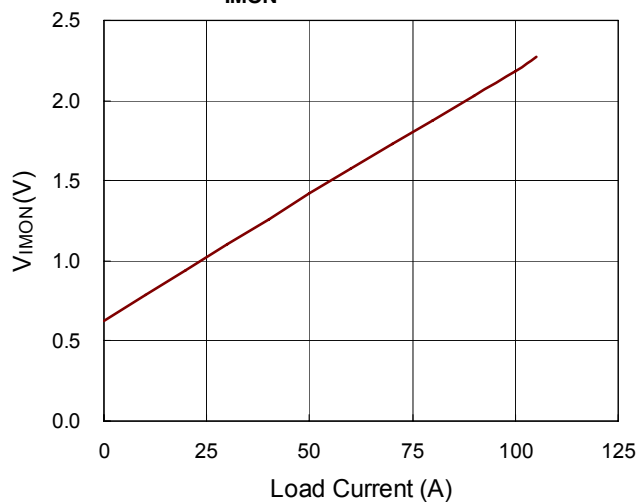

**Applications information**

The RT8884B is a 4/3/2/1 multiphase synchronous Buck controller designed to meet Intel VR12.5 compatible CPU specification with a serial SVID control interface. The controller uses an ADC to implement all kinds of settings to save a total number of pins for easily using and increasing PCB space utilization. RT8884B is used in notebook, desktop computer and server.

**G-NAVP™ Control Mode**

The RT8884B adopts the G-NAVP™ controller, which is a current mode constant on-time control with DC offset cancellation. The approach can not only improve DC offset problem for increasing system accuracy but also provide fast transient response. For the RT8884B, when current feedback signal reaches comp signal to generate an on-time width to achieve PWM modulation. Figure 1 shows the basic G-NAVP™ behavior waveforms in continuous conduct mode (CCM).

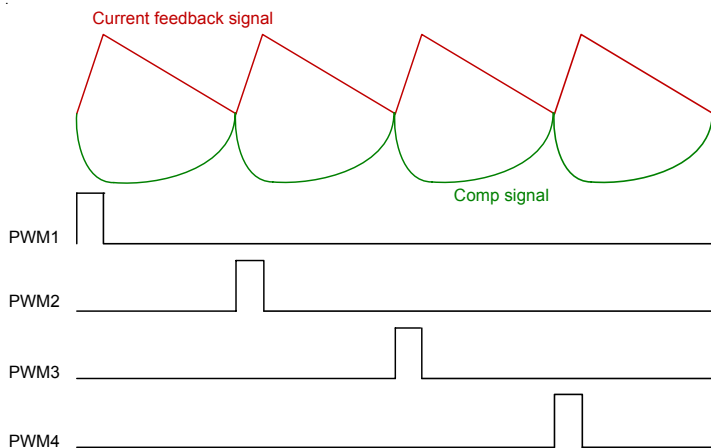

Figure 1 (a). G-NAVP™ Behavior Waveforms in CCM in Steady State

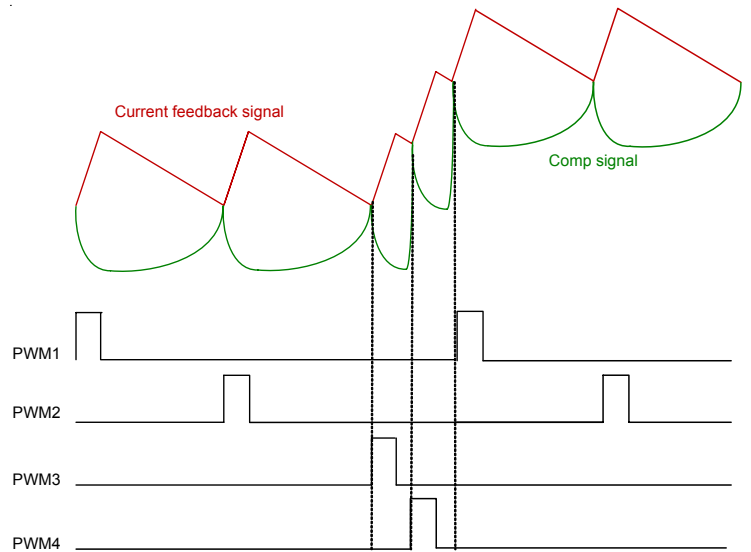

Figure 1 (b). G-NAVP™ Behavior Waveforms in CCM in Load Transient.

**Diode Emulation Mode (DEM)**

As well-known, the dominate power loss is switching related loss during light load, hence VR needs to be operated in asynchronous mode (or called discontinuous conduct mode, DCM) to reduce switching related loss since switching frequency is dependent on loading in the asynchronous mode. RT8884B can operate in Diode Emulation Mode (DEM) in order to improve light load efficiency. In DEM operation, the behavior of the low side MOSFET(s) needs to work like a diode, that is, the low side MOSFET(s) will be turned on when the phase voltage is a negative value, i.e. the inductor current follows from source to drain of low side MOSFET(s). The low side MOSFET(s) will be turned off when phase voltage is a positive value, i.e. reversed current is not allowed. Figure 2 shows the control behavior in DEM. Figure 3 shows the G-NAVP™ operation in DEM to illustrate the control behaviors. When the load decreases, the discharge time of output capacitors increases during UGATE and LGATE are turned off. Hence, the switching frequency and switching loss will be reduced to improve efficiency in light load condition.

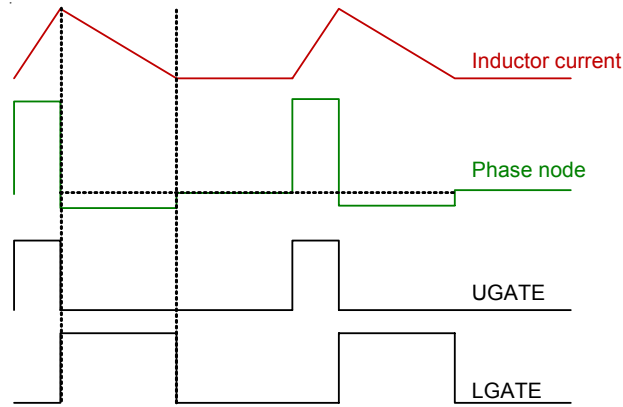
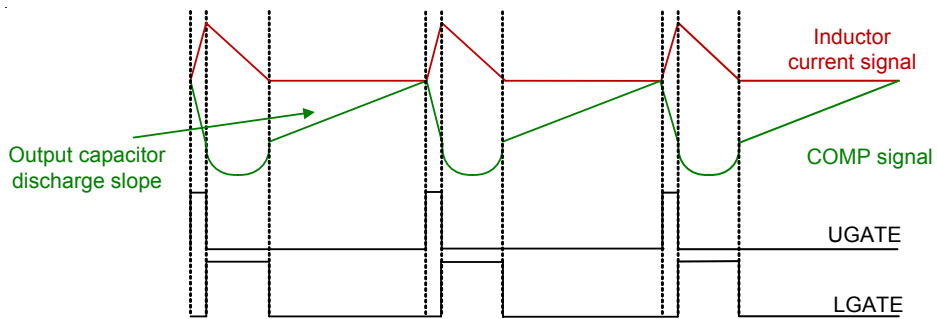
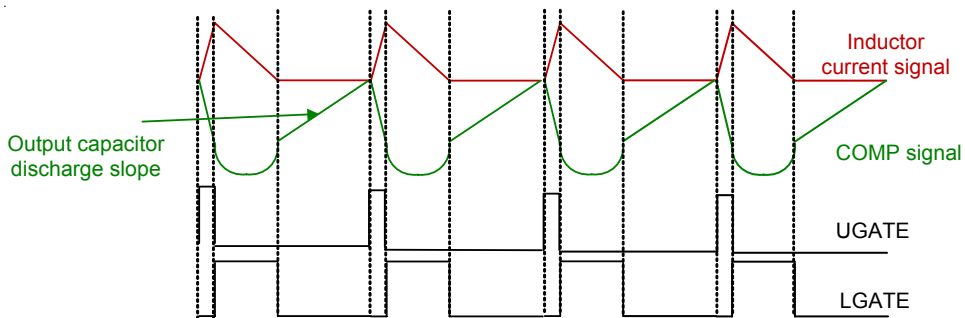

Figure 2. Diode Emulation Mode (DEM) in Steady State



(a). Lighter Load Condition  
Capacitor discharge slope is lower than Figure 3 (b).



(b). Load Increased Condition  
Capacitor discharge slope is higher than Figure 3 (a).

Figure 3. G-NAVP™ Operation in DEM.

### Phase Interleaving Function

RT884B is a multiphase controller, which has a phase interleaving function, 90 degree phase shift for 4-phase operation, 120 degree phase shift for 3-phase operation and 180 degree phase shift for 2-phase operation which can help reduce output voltage ripple and EMI problem.

### Switching Frequency (TON) Setting

RT884B is one kind of constant on-time control. The patented CCRCOT (Constant Current Ripple COT) technology can generate an adaptive on-time with input voltage and VID code to obtain a constant current ripple. So that the output voltage ripple can be controlled nearly like a constant as different input and output voltage change. Connect a resistor  $R_{TON}$  between input terminal and TONSET pin to set the on-time width.

$$T_{ON} = \frac{R_{TON} \times C \times 2.2}{V_{IN} - V_{DAC}} \quad (V_{DAC} < 2.2V)$$

$$T_{ON} = \frac{R_{TON} \times C \times V_{DAC}}{V_{IN} - V_{DAC}} \quad (V_{DAC} \geq 2.2V)$$

Where  $C = 18.2pF$ . By using the relationship between  $T_{ON}$  and  $f_{SW}$ , the switching frequency  $f_{SW}$  is :

$$f_{SW(MAX)} = \left( \frac{1}{T_{ON(MAX)}} \right) \times \left( \frac{V_{DAC(MAX)}}{V_{IN(MAX)}} \right)$$

Where

$f_{SW(MAX)}$  is the maximum switching frequency.

$V_{DAC(MAX)}$  is the maximum  $V_{DAC}$  of application.

$V_{IN(MAX)}$  is the maximum application input voltage.

$T_{ON(MAX)}$  is derived from  $T_{ON}$  equation with maximum parameters ( $V_{IN(MAX)}$ ,  $V_{DAC(MAX)}$ ).

When load increases, on-time keeps constant. The off-time width will be reduced so that loading can load more power from input terminal to regulate output voltage. Hence the loading current increases in case the switching frequency also increases. Higher switching frequency operation can reduce power components' size and PCB space, trading off the whole efficiency since switching related loss increases, vice versa.

### Per Phase Current Sense

In the RT884B, the current signal is used for load-line setting and OC (Over Current) protection. The inductor current sense method adopts the lossless current sensing for allowing high efficiency as illustrated in the Figure 4. When inductance and DCR time constant is equal to  $R_x C_x$  filter network time constant, a voltage  $I_{LX} \times DCR$  will drop on  $C_x$  to generate inductor current signal. According to the Figure 4, the  $I_{SENxN}$  is as follows :

$$I_{SENxN} = \frac{I_{LX} \times DCR}{R_{CSx}}$$

Where  $LX / DCR = R_x C_x$  is held. The method can get high efficiency performance, but DCR value will be drifted by temperature, a NTC resistor should add in the resistor network in the IMON pin to achieve DCR thermal compensation.

In RT884B design, the resistance of the  $R_{CSx}$  is restricted to  $680\Omega$ ; moreover, the accuracy of  $R_{CS}$  is recommended to be 1% or higher.

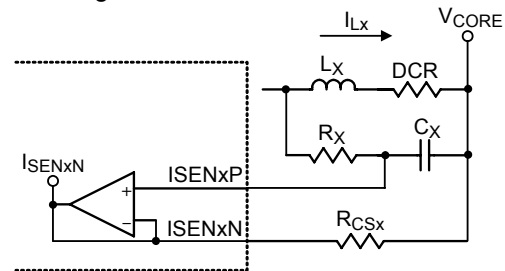

Figure 4. Lossless Current Sense Method

### Total Current Sense

Total current sense method is a patented topology, unlike conventional current sense method requiring a NTC resistor in per phase current loop for thermal compensation. RT884B adopts the total current sense method requiring only one NTC resistor for thermal compensation, and NTC resistor cost can be saved by using this method. Figure 5 shows the total current sense method which connecting the resistor network between the IMON and VREF pins to set a part of current loop gain for load-line (droop) setting and set accurate over current protection.

$$V_{IMON} - V_{REF} = \frac{DCR}{R_{CS}} \times R_{EQ} \times (I_{L1} + I_{L2} + I_{L3} + I_{L4})$$

$R_{EQ}$  includes a NTC resistor to compensate DCR thermal drifting for high accuracy load-line (droop).

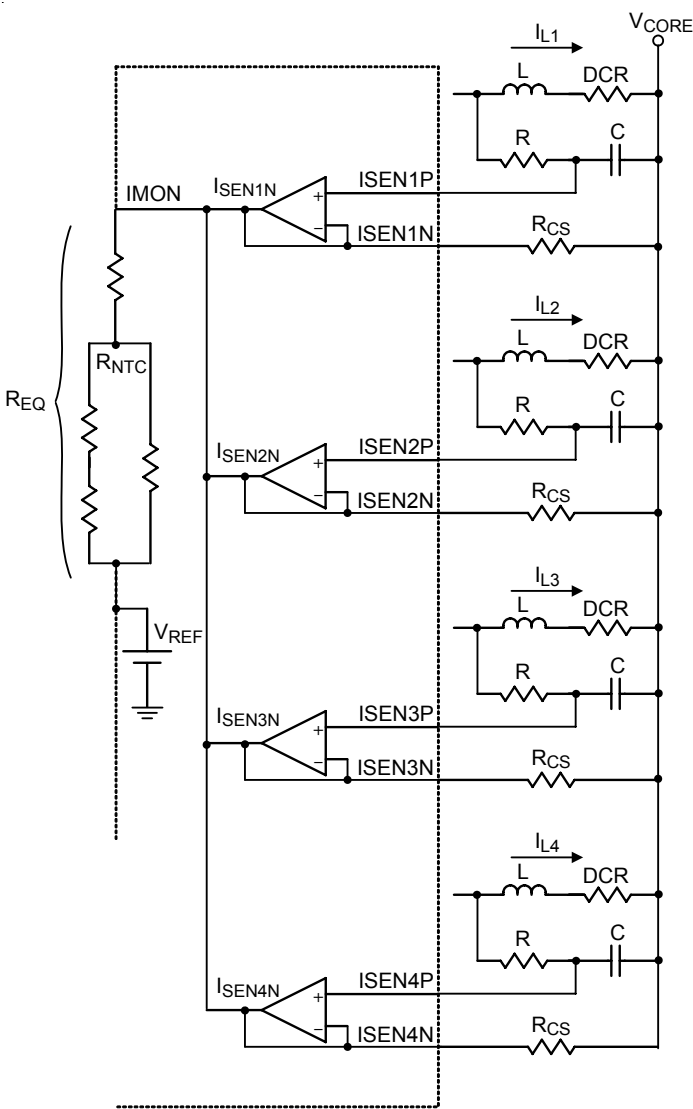

Figure 5. Total Current Sense Method

**Load-Line (Droop) Setting**

The G-NAVP™ topology can set load-line (droop) via the current loop and the voltage loop, the load-line is a slope between load current ICC and output voltage VCORE as shown in Figure 6. Figure 7 shows the voltage control and current loop. By using both loops, the load-line (droop) can easily be set. The load-line set equation is :

$$R_{LL} = \frac{A_I}{A_V} = \frac{\frac{1}{2} \times \frac{DCR}{R_{CS}} \times R_{EQ}}{\frac{R_2}{R_1}} \text{ (m}\Omega\text{)}$$

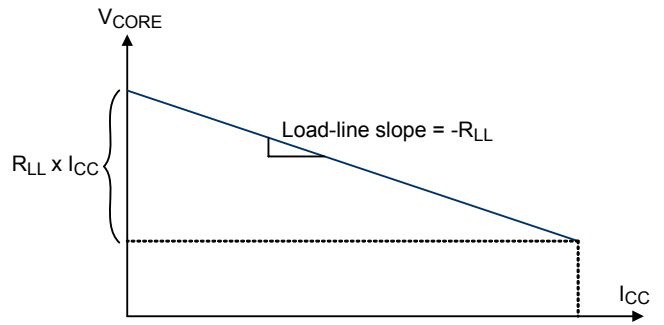

Figure 6. Load-Line (Droop)

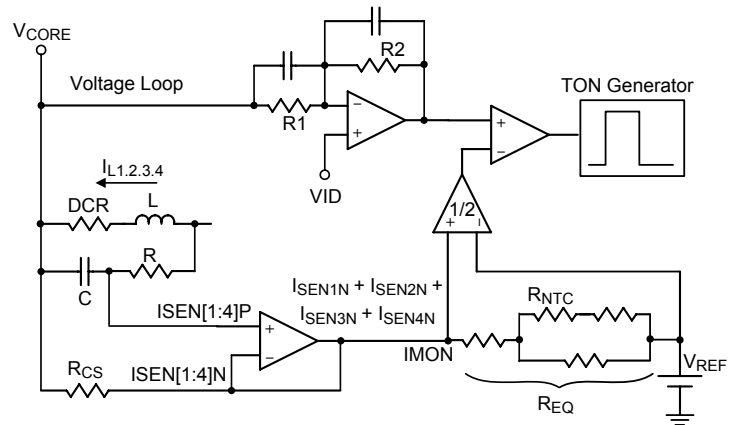

Figure 7. Voltage Loop and Current Loop

**Compensator Design**

The compensator of RT8884B doesn't need a complex type II or type III compensator to optimize control loop performance. It can adopt a simple type I compensator (one pole, one zero) in G-NAVP™ topology to achieve constant output impedance design for Intel VR12.5 ACLL specification. The one pole one zero compensator is shown as Figure 8, the transfer function of compensator should be designed as the following transfer function to achieve constant output impedance, i.e. Zo(s) = load-line slope in the entire frequency range :

$$G_{CON} (s) \approx \frac{A_I}{R_{LL}} \times \frac{1 + \frac{s}{\pi \times f_{sw}}}{1 + \frac{s}{\omega_{ESR}}}$$

Where  $A_i$  is current loop gain,  $R_{LL}$  is load-line,  $f_{sw}$  is switching frequency and  $\omega_{ESR}$  is a pole that should be located at  $1 / (C_{OUT} \times ESR)$ . Then the  $C1$  and  $C2$  should be designed as follows :

$$C1 = \frac{1}{R1 \times \pi \times f_{sw}}$$

$$C2 = \frac{C_{OUT} \times ESR}{R2}$$

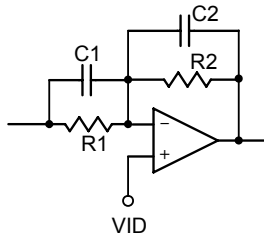

Figure 8. Type I Compensator

### Multi-Function Pin Setting Mechanism

For reducing total pin number of package, the SET[1:2] pins adopt the multi-function pin setting mechanism in RT8884B. Figure 9 illustrates this operating mechanism. First, external voltage divider is to set the Function 1 and then internal current source  $80\mu A$  is to set the Function 2. The setting voltage of Function 1 and Function 2 can be represented as follows :

$$V_{Function\ 1} = \frac{R2}{R1 + R2} \times V_{CC}$$

$$V_{Function\ 2} = 80\mu A \times \frac{R1 \times R2}{R1 + R2}$$

All function setting will be done within  $500\mu s$  after power ready (POR).

If  $V_{Function\ 1}$  and  $V_{Function\ 2}$  are determined,  $R1$  and  $R2$  can be calculated as follows :

$$R1 = \frac{V_{CC} \times V_{Function\ 2}}{80\mu A \times V_{Function\ 1}}$$

$$R2 = \frac{R1 \times V_{Function\ 1}}{V_{CC} - V_{Function\ 1}}$$

In addition, Richtek provides a Microsoft Excel-based spreadsheet to help design the SETx resistor network for RT8884B.

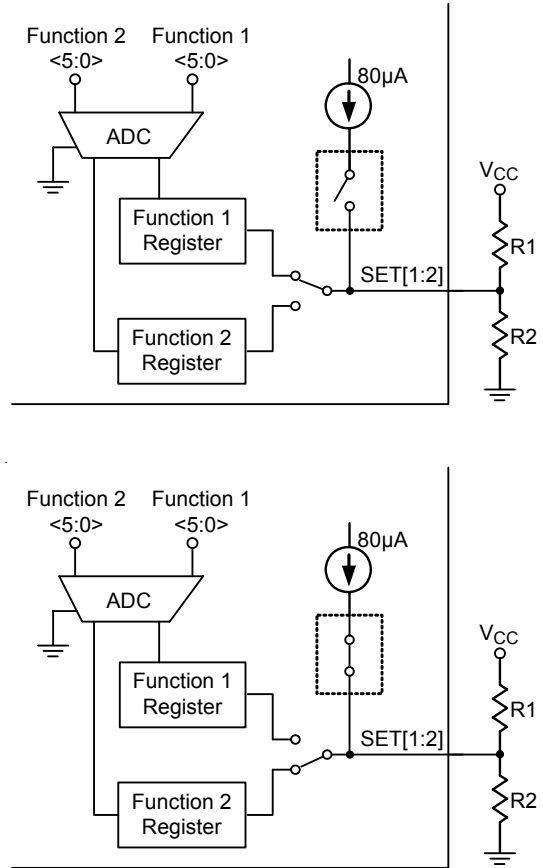

Figure 9. Multi-Function Pin Setting Mechanism

Connecting a  $R3$  resistor from SET[1:2] pin to the middle node of voltage divider can help to fine tune the set voltage of Function 2, which does not affect the set voltage of Function 1. The Figure 10 shows the setting method and the set voltage of Function 1 and Function 2 can be represented as :

$$V_{Function\ 1} = \frac{R2}{R1 + R2} \times V_{CC}$$

$$V_{Function\ 2} = 80\mu A \times \left( R3 + \frac{R1 \times R2}{R1 + R2} \right)$$

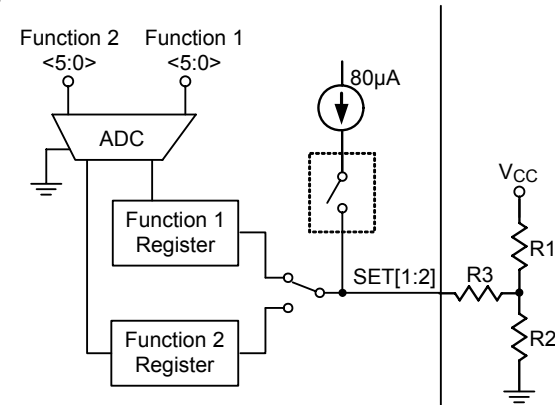

Figure 10. Multi-Function Pin Setting Mechanism with a R3 Resistor to Fine Tune the Set Voltage of Function 2

**Quick Response (QR) Mechanism**

When the transient load step-up becomes quite large, it is difficult for loop response to meet the energy transfer. Hence, that output voltage generate undershoot to fail specification. RT8884B has Quick Response (QR) mechanism being able to improve this issue. It adopts a nonlinear control mechanism which can disable interleaving function and simultaneously to turn on all UGATE one pulse at instantaneous step-up transient load to restrain the output voltage drooping, Figure 11 shows the QR behavior.

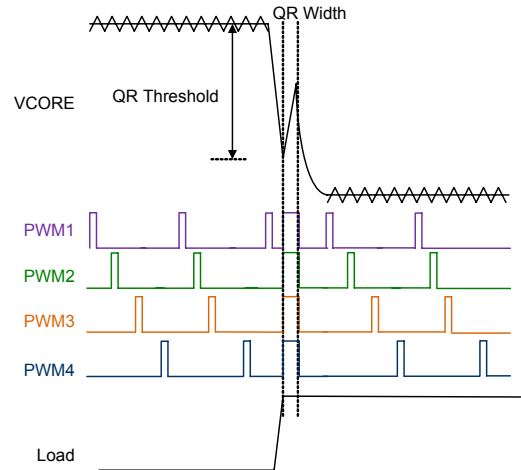

Figure 11. Quick Response Mechanism

The output voltage signal behavior needs to be detected so that QR mechanism can be triggered. The output voltage signal is via a remote sense line to connect at the VSEN pin that is shown in Figure 12. The QR mechanism needs to set QR width and QR threshold. Both definitions are shown in Figure 9. A proper QR mechanism set can meet different applications. The SET2 pin is a multi-function pin which can set QR threshold, QR width and ICCMAX.

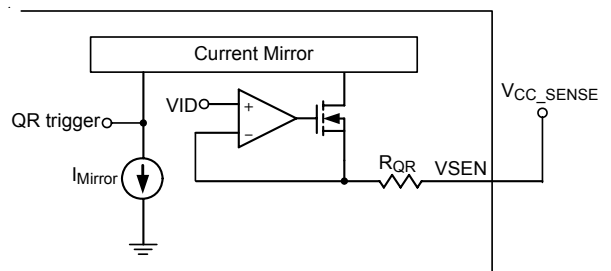

Figure 12. Simplified QR Trigger Schematic

An internal current source 80µA is used in multi-function pin setting mechanism. For example, 35mV QR threshold and 1.3 x TON QR width are set. According to the Table 4, the set voltage should be between 0.4504V and 0.4723V. Please note that a high accuracy resistor is needed for this setting accuracy, <1% error tolerance is recommended.

In the Table 4, there are some “No Use” marks in QRWIDTH section. It means that user should not use it to avoid the possibility of shift digital code due to tolerance concern.

Table 4 : SET2 Pin Setting for QR Threshold and QR Width

$V_{QR\_SET} = 80\mu A \times \frac{R1 \times R2}{R1 + R2}$				QR_TH <2:0>	QRWIDTH <2:0>	QR Threshold	QR Width (%TON)
Min	Typical	Max	unit				
0.000	10.948	21.896	mV	000	000	Disable	No Use
25.024	35.973	46.921	mV		001		155%
50.049	60.997	71.945	mV		010		133%
75.073	86.022	96.970	mV		011		111%
100.098	111.046	121.994	mV		100		89%
125.122	136.070	147.019	mV		101		67%
150.147	161.095	172.043	mV		110		44%
175.171	186.119	197.067	mV		111		No Use
200.196	211.144	222.092	mV		000		No Use
225.220	236.168	247.116	mV	001	001	155%	
250.244	261.193	272.141	mV		010	133%	
275.269	286.217	297.165	mV		011	111%	
300.293	311.241	322.190	mV		100	89%	
325.318	336.266	347.214	mV		101	67%	
350.342	361.290	372.239	mV		110	44%	
375.367	386.315	397.263	mV		111	No Use	
400.391	411.339	422.287	mV		000	No Use	
425.415	436.364	447.312	mV		010	001	155%
450.440	461.388	472.336	mV	010		133%	
475.464	486.413	497.361	mV	011		111%	
500.489	511.437	522.385	mV	100		89%	
525.513	536.461	547.410	mV	101		67%	
550.538	561.486	572.434	mV	110		44%	
575.562	586.510	597.458	mV	111		No Use	
600.587	611.535	622.483	mV	011		000	No Use
625.611	636.559	647.507	mV			001	155%
650.635	661.584	672.532	mV		010	133%	
675.660	686.608	697.556	mV		011	111%	
700.684	711.632	722.581	mV		100	89%	
725.709	736.657	747.605	mV		101	67%	
750.733	761.681	772.630	mV		110	44%	
775.758	786.706	797.654	mV		111	No Use	
800.782	811.730	822.678	mV		100	000	No Use
825.806	836.755	847.703	mV	001		155%	
850.831	861.779	872.727	mV	010		133%	
875.855	886.804	897.752	mV	011		111%	
900.880	911.828	922.776	mV	100		89%	
925.904	936.852	947.801	mV	101		67%	
950.929	961.877	972.825	mV	110		44%	
975.953	986.901	997.849	mV	111		No Use	

$V_{QR\_SET} = 80\mu A \times \frac{R1 \times R2}{R1 + R2}$				QR_TH <2:0>	QRWIDTH <2:0>	QR Threshold	QR Width (%TON)
Min	Typical	Max	unit				
1000.978	1011.926	1022.874	mV	101	000	50mV	No Use
1026.002	1036.950	1047.898	mV		001		155%
1051.026	1061.975	1072.923	mV		010		133%
1076.051	1086.999	1097.947	mV		011		111%
1101.075	1112.023	1122.972	mV		100		89%
1126.100	1137.048	1147.996	mV		101		67%
1151.124	1162.072	1173.021	mV		110		44%
1176.149	1187.097	1198.045	mV		111		No Use
1201.173	1212.121	1223.069	mV		110		000
1226.197	1237.146	1248.094	mV	001		155%	
1251.222	1262.170	1273.118	mV	010		133%	
1276.246	1287.195	1298.143	mV	011		111%	
1301.271	1312.219	1323.167	mV	100		89%	
1326.295	1337.243	1348.192	mV	101		67%	
1351.320	1362.268	1373.216	mV	110		44%	
1376.344	1387.292	1398.240	mV	111		No Use	
1401.369	1412.317	1423.265	mV	111		000	60mV
1426.393	1437.341	1448.289	mV		001	155%	
1451.417	1462.366	1473.314	mV		010	133%	
1476.442	1487.390	1498.338	mV		011	111%	
1501.466	1512.414	1523.363	mV		100	89%	
1526.491	1537.439	1548.387	mV		101	67%	
1551.515	1562.463	1573.412	mV		110	44%	
1576.540	1587.488	1598.436	mV		111	No Use	

**Dynamic VID (DVID) Compensation**

When VID transition event occurs, a charge current will be generated in the loop to cause that DVID performance is deteriorated by this induced charge current, the phenomenon is called droop effect. The droop effect is shown in Figure 13. When VID up transition occurs, the output capacitor will be charged by inductor current. Since current signal is sensed in inductor, an induced charge current will appear in control loop. The induced charge current will produce a voltage drop in R1 to cause output voltage to have a droop effect. Due to this, VID transition performance will be deteriorated.

The RT8884B provides a DVID compensation function. A virtual charge current signal can be established by the SET1 pin to cancel the real induced charge current signal and the virtual charge current signal is defined in Figure 15. Figure 14 shows the operation of cancelling droop effect. A virtual charge current signal is established first and then VID signal plus virtual charge current signal is generated in FB pin. Hence, an induced charge current signal flows to R1 and is cancelled to reduce droop effect.

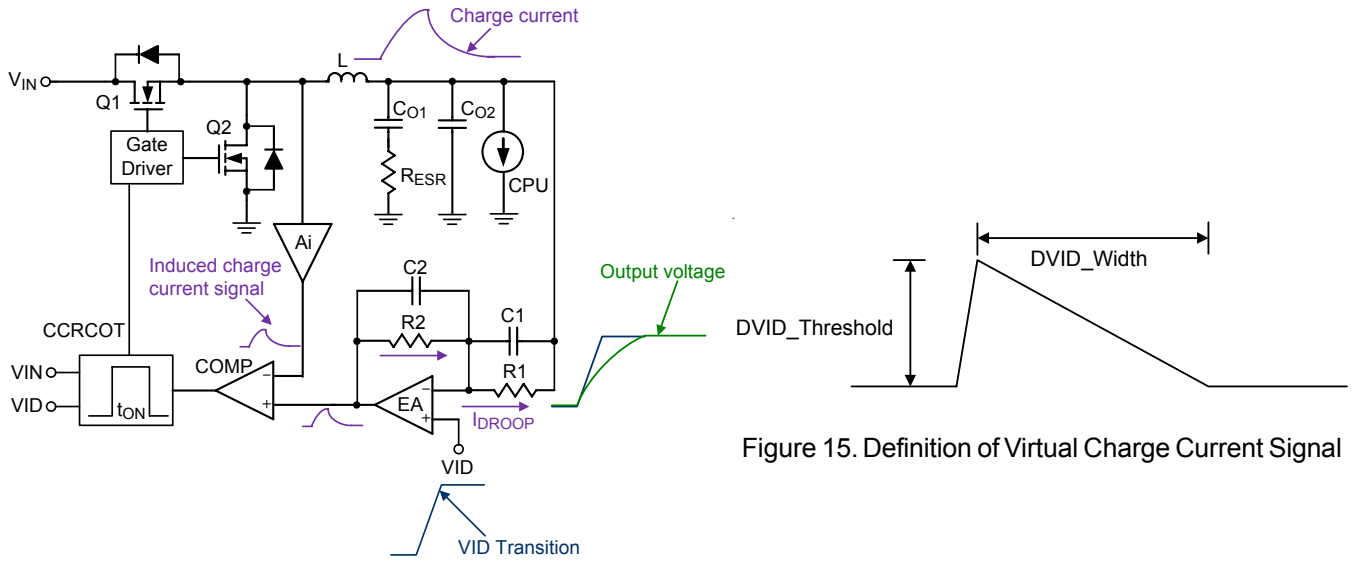

Figure 13. Droop Effect in VID Transition

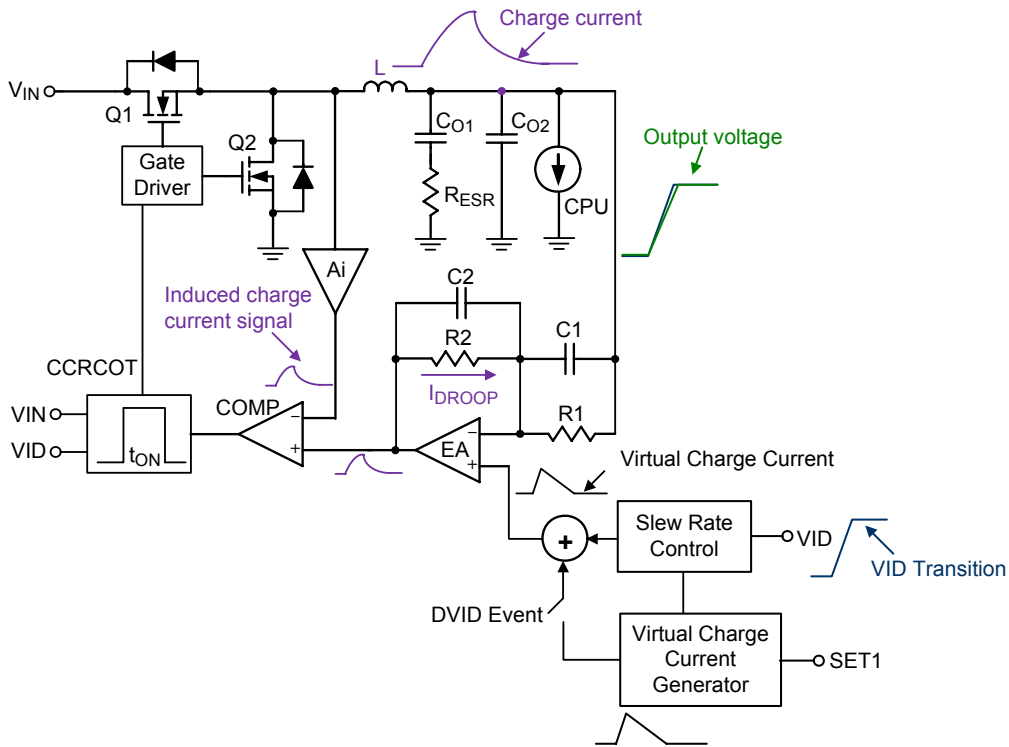

Figure 14. DVID Compensation

Table 5 and Table 6 show the DVID\_Threshold and DVID\_Width settings in SET1 pin. For example, 25mV DVID\_Threshold and 72μs DVID\_Width are designed (OCP sets as 100% ICCMAX, and RSET sets as 100% Ramp current). The DVID\_Width is set by an external voltage divider and the DVID\_Threshold is set by an internal current

source 80μA by the multi-function pin setting mechanism. According to the Table 5 and Table 6, the DVID\_Threshold set voltage should be between 0.225V and 0.247V and the DVID\_Width set voltage should be between 0.275V and 0.297V. Please note that a high accuracy resistor is needed for this setting, <1% error tolerance is recommended.

**Table 5 : SET1 Pin Setting for DVID\_Threshold**

$V_{DVID\_Threshold} = 80\mu A \times \frac{R1 \times R2}{R1 + R2}$				DVID_TH <2:0>	OCS <2:0>	DVID_Threshold	OCP = %ICCMAX
Min	Typical	Max	unit				
0.000	10.948	21.896	mV	000	000	15mV	No Use
25.024	35.973	46.921	mV		001		100%
50.049	60.997	71.945	mV		010		110%
75.073	86.022	96.970	mV		011		120%
100.098	111.046	121.994	mV		100		130%
125.122	136.070	147.019	mV		101		140%
150.147	161.095	172.043	mV		110		150%
175.171	186.119	197.067	mV		111		No Use
200.196	211.144	222.092	mV		001		000
225.220	236.168	247.116	mV	001		100%	
250.244	261.193	272.141	mV	010		110%	
275.269	286.217	297.165	mV	011		120%	
300.293	311.241	322.190	mV	100		130%	
325.318	336.266	347.214	mV	101		140%	
350.342	361.290	372.239	mV	110		150%	
375.367	386.315	397.263	mV	111		No Use	
400.391	411.339	422.287	mV	010		000	35mV
425.415	436.364	447.312	mV		001	100%	
450.440	461.388	472.336	mV		010	110%	
475.464	486.413	497.361	mV		011	120%	
500.489	511.437	522.385	mV		100	130%	
525.513	536.461	547.410	mV		101	140%	
550.538	561.486	572.434	mV		110	150%	
575.562	586.510	597.458	mV		111	No Use	
600.587	611.535	622.483	mV		011	000	
625.611	636.559	647.507	mV	001		100%	
650.635	661.584	672.532	mV	010		110%	
675.660	686.608	697.556	mV	011		120%	
700.684	711.632	722.581	mV	100		130%	
725.709	736.657	747.605	mV	101		140%	
750.733	761.681	772.630	mV	110		150%	
775.758	786.706	797.654	mV	111		No Use	
800.782	811.730	822.678	mV	100		000	55mV
825.806	836.755	847.703	mV		001	100%	
850.831	861.779	872.727	mV		010	110%	
875.855	886.804	897.752	mV		011	120%	
900.880	911.828	922.776	mV		100	130%	
925.904	936.852	947.801	mV		101	140%	
950.929	961.877	972.825	mV		110	150%	
975.953	986.901	997.849	mV		111	No Use	

$V_{DVID\_Threshold} = 80\mu A \times \frac{R1 \times R2}{R1 + R2}$						DVID_Threshold	OCP = %ICCMAX
Min	Typical	Max	unit	DVID_TH <2:0>	OCS <2:0>		
1000.978	1011.926	1022.874	mV	101	000	65mV	No Use
1026.002	1036.950	1047.898	mV		001		100%
1051.026	1061.975	1072.923	mV		010		110%
1076.051	1086.999	1097.947	mV		011		120%
1101.075	1112.023	1122.972	mV		100		130%
1126.100	1137.048	1147.996	mV		101		140%
1151.124	1162.072	1173.021	mV		110		150%
1176.149	1187.097	1198.045	mV		111		No Use
1201.173	1212.121	1223.069	mV	110	000	75mV	No Use
1226.197	1237.146	1248.094	mV		001		100%
1251.222	1262.170	1273.118	mV		010		110%
1276.246	1287.195	1298.143	mV		011		120%
1301.271	1312.219	1323.167	mV		100		130%
1326.295	1337.243	1348.192	mV		101		140%
1351.320	1362.268	1373.216	mV		110		150%
1376.344	1387.292	1398.240	mV		111		No Use
1401.369	1412.317	1423.265	mV	111	000	85mV	No Use
1426.393	1437.341	1448.289	mV		001		100%
1451.417	1462.366	1473.314	mV		010		110%
1476.442	1487.390	1498.338	mV		011		120%
1501.466	1512.414	1523.363	mV		100		130%
1526.491	1537.439	1548.387	mV		101		140%
1551.515	1562.463	1573.412	mV		110		150%
1576.540	1587.488	1598.436	mV		111		No Use

**Table 6 : SET1 Pin Setting for DVID\_Width**

$V_{DVID\_Width} = \frac{R2}{R1+R2} \times V_{CC}$				DVID_WTH <2:0>	RSET <2:0>	DVID_Width	RSET % 130k R <sub>TON</sub>
Min	Typical	Max	unit				
0.000	10.948	21.896	mV	000	000	48μs	No Use
25.024	35.973	46.921	mV		001		75%
50.049	60.997	71.945	mV		010		87.5%
75.073	86.022	96.970	mV		011		100%
100.098	111.046	121.994	mV		100		112.5%
125.122	136.070	147.019	mV		101		125%
150.147	161.095	172.043	mV		110		137.5%
175.171	186.119	197.067	mV		111		No Use
200.196	211.144	222.092	mV		001		000
225.220	236.168	247.116	mV	001		75%	
250.244	261.193	272.141	mV	010		87.5%	
275.269	286.217	297.165	mV	011		100%	
300.293	311.241	322.190	mV	100		112.5%	
325.318	336.266	347.214	mV	101		125%	
350.342	361.290	372.239	mV	110		137.5%	
375.367	386.315	397.263	mV	111		No Use	
400.391	411.339	422.287	mV	010		000	96μs
425.415	436.364	447.312	mV		001	75%	
450.440	461.388	472.336	mV		010	87.50%	
475.464	486.413	497.361	mV		011	100%	
500.489	511.437	522.385	mV		100	112.5%	
525.513	536.461	547.410	mV		101	125%	
550.538	561.486	572.434	mV		110	137.5%	
575.562	586.510	597.458	mV		111	No Use	
600.587	611.535	622.483	mV		011	000	
625.611	636.559	647.507	mV	001		75%	
650.635	661.584	672.532	mV	010		87.50%	
675.660	686.608	697.556	mV	011		100%	
700.684	711.632	722.581	mV	100		112.50%	
725.709	736.657	747.605	mV	101		125%	
750.733	761.681	772.630	mV	110		137.5%	
775.758	786.706	797.654	mV	111		No Use	
800.782	811.730	822.678	mV	100		000	144μs
825.806	836.755	847.703	mV		001	75%	
850.831	861.779	872.727	mV		010	87.5%	
875.855	886.804	897.752	mV		011	100%	
900.880	911.828	922.776	mV		100	112.50%	
925.904	936.852	947.801	mV		101	125%	
950.929	961.877	972.825	mV		110	137.5%	
975.953	986.901	997.849	mV		111	No Use	

$V_{DVID\_Width} = \frac{R2}{R1+R2} \times V_{CC}$				DVID_WTH <2:0>	RSET <2:0>	DVID_Width	RSET % 130k R <sub>TON</sub>
Min	Typical	Max	unit				
1000.978	1011.926	1022.874	mV	101	000	168μs	No Use
1026.002	1036.950	1047.898	mV		001		75%
1051.026	1061.975	1072.923	mV		010		87.5%
1076.051	1086.999	1097.947	mV		011		100%
1101.075	1112.023	1122.972	mV		100		112.5%
1126.100	1137.048	1147.996	mV		101		125%
1151.124	1162.072	1173.021	mV		110		137.5%
1176.149	1187.097	1198.045	mV		111		No Use
1201.173	1212.121	1223.069	mV	110	000	192μs	No Use
1226.197	1237.146	1248.094	mV		001		75%
1251.222	1262.170	1273.118	mV		010		87.5%
1276.246	1287.195	1298.143	mV		011		100%
1301.271	1312.219	1323.167	mV		100		112.5%
1326.295	1337.243	1348.192	mV		101		125%
1351.320	1362.268	1373.216	mV		110		137.5%
1376.344	1387.292	1398.240	mV		111		No Use
1401.369	1412.317	1423.265	mV	111	000	216μs	No Use
1426.393	1437.341	1448.289	mV		001		75%
1451.417	1462.366	1473.314	mV		010		87.50%
1476.442	1487.390	1498.338	mV		011		100%
1501.466	1512.414	1523.363	mV		100		112.5%
1526.491	1537.439	1548.387	mV		101		125%
1551.515	1562.463	1573.412	mV		110		137.5%
1576.540	1587.488	1598.436	mV		111		No Use

**Ramp Compensation**

G-NAVP™ topology is one type of ripple based control that has fast transient response, no beat frequency issue in high repetitive load frequency operation and lower BOM cost. However, ripple based control usually has no good noise immunity. The RT8884B provides that the ramp compensation to increase noise immunity and reduce jitter at the switching node. Figure 16 shows the ramp compensation.

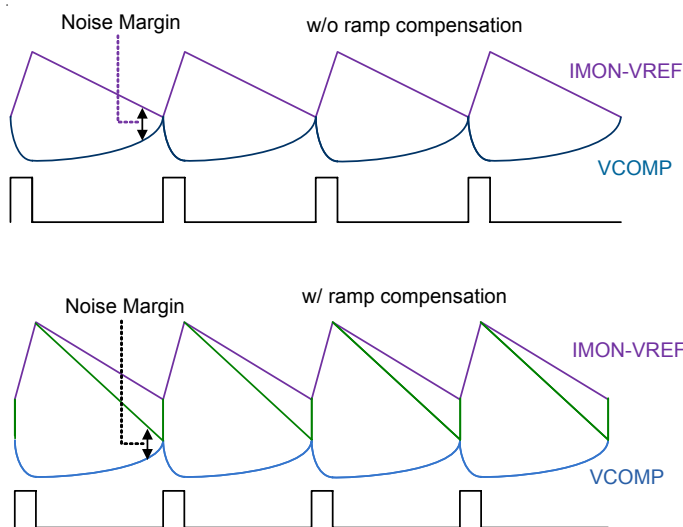

Figure 16. Ramp Compensation

For the RT8884B, the ramp compensation also needs to be considered during mode transition from PS0/1 to PS2. For achieving smooth mode transition into PS2, a proper ramp compensation design is necessary. Since the ramp compensation needs to be proportional to the on-time, in others words, ramp compensation is dependent on  $R_{TON}$  design. The Table 6 shows the relationship between  $R_{TON}$  and ramp compensation. For example, when designed  $R_{TON}$  is 100kΩ, the RAMP is set as  $\frac{130k}{100k} \times 100\%$ .

**Current Monitor, IMON**

RT8884B includes a current monitor (IMON) function which can be used to detect over current protection and the maximum processor current ICCMAX, and also sets a part of current gain in the load-line setting. It produces an analog voltage proportional to output current between the IMON and VREF pins.

The calculation for IMON-VREF voltage is shown as below :

$$V_{IMON} - V_{REF} = \frac{DCR}{R_{CS}} \times R_{EQ} \times (I_{L1} + I_{L2} + I_{L3} + I_{L4})$$

Where  $I_{L1} + I_{L2} + I_{L3} + I_{L4}$  are output current and the definitions of DCR,  $R_{CS}$  and  $R_{EQ}$  can refer to Figure 6.

**Maximum Processor Current Setting, ICCMAX**

The maximum processor current ICCMAX can be set by the SET2 pin. ICCMAX register is set by an external voltage divider by the multi-function mechanism. The Table 7 shows the ICCMAX setting in SET2 pin. For example,  $I_{CCMAX} = 106A$ , the  $V_{ICCMAX}$  needs to be set as 0.67 typically. Additionally,  $V_{IMON} - V_{REF}$  needs to be set as 1.6V when  $I_{L1} + I_{L2} + I_{L3} + I_{L4} = 106A$ . The ICCMAX alert signal will be pulled to low level if  $V_{IMON} - V_{REF} = 1.6V$ .

Table 7 : SET2 Pin Setting for ICCMAX

$V_{ICCMAX} = \frac{R2}{R1+R2} \times V_{CC}$				ICCMAX	Unit
Min	Typical	Max	Unit		
0.000	3.128	6.256	mV	0	A
12.512	15.640	18.768	mV	2	A
25.024	28.152	31.281	mV	4	A
37.537	40.665	43.793	mV	6	A
50.049	53.177	56.305	mV	8	A
62.561	65.689	68.817	mV	10	A
75.073	78.201	81.329	mV	12	A
87.586	90.714	93.842	mV	14	A
100.098	103.226	106.354	mV	16	A
112.610	115.738	118.866	mV	18	A
125.122	128.250	131.378	mV	20	A
137.634	140.762	143.891	mV	22	A
150.147	153.275	156.403	mV	24	A
162.659	165.787	168.915	mV	26	A
175.171	178.299	181.427	mV	28	A
187.683	190.811	193.939	mV	30	A
200.196	203.324	206.452	mV	32	A
212.708	215.836	218.964	mV	34	A
225.220	228.348	231.476	mV	36	A
237.732	240.860	243.988	mV	38	A
250.244	253.372	256.500	mV	40	A
262.757	265.885	269.013	mV	42	A
275.269	278.397	281.525	mV	44	A
287.781	290.909	294.037	mV	46	A
300.293	303.421	306.549	mV	48	A
312.805	315.934	319.062	mV	50	A
325.318	328.446	331.574	mV	52	A
337.830	340.958	344.086	mV	54	A
350.342	353.470	356.598	mV	56	A
362.854	365.982	369.110	mV	58	A
375.367	378.495	381.623	mV	60	A
387.879	391.007	394.135	mV	62	A
400.391	403.519	406.647	mV	64	A
412.903	416.031	419.159	mV	66	A
425.415	428.543	431.672	mV	68	A
437.928	441.056	444.184	mV	70	A
450.440	453.568	456.696	mV	72	A
462.952	466.080	469.208	mV	74	A
475.464	478.592	481.720	mV	76	A
487.977	491.105	494.233	mV	78	A
500.489	503.617	506.745	mV	80	A

$V_{ICCMAX} = \frac{R2}{R1+R2} \times V_{CC}$				ICCMAX	Unit
Min	Typical	Max	Unit		
513.001	516.129	519.257	mV	82	A
525.513	528.641	531.769	mV	84	A
538.025	541.153	544.282	mV	86	A
550.538	553.666	556.794	mV	88	A
563.050	566.178	569.306	mV	90	A
575.562	578.690	581.818	mV	92	A
588.074	591.202	594.330	mV	94	A
600.587	603.715	606.843	mV	96	A
613.099	616.227	619.355	mV	98	A
625.611	628.739	631.867	mV	100	A
638.123	641.251	644.379	mV	102	A
650.635	653.763	656.891	mV	104	A
663.148	666.276	669.404	mV	106	A
675.660	678.788	681.916	mV	108	A
688.172	691.300	694.428	mV	110	A
700.684	703.812	706.940	mV	112	A
713.196	716.325	719.453	mV	114	A
725.709	728.837	731.965	mV	116	A
738.221	741.349	744.477	mV	118	A
750.733	753.861	756.989	mV	120	A
763.245	766.373	769.501	mV	122	A
775.758	778.886	782.014	mV	124	A
788.270	791.398	794.526	mV	126	A
800.782	803.910	807.038	mV	128	A
813.294	816.422	819.550	mV	130	A
825.806	828.935	832.063	mV	132	A
838.319	841.447	844.575	mV	134	A
850.831	853.959	857.087	mV	136	A
863.343	866.471	869.599	mV	138	A
875.855	878.983	882.111	mV	140	A
888.368	891.496	894.624	mV	142	A
900.880	904.008	907.136	mV	144	A
913.392	916.520	919.648	mV	146	A
925.904	929.032	932.160	mV	148	A
938.416	941.544	944.673	mV	150	A
950.929	954.057	957.185	mV	152	A
963.441	966.569	969.697	mV	154	A
975.953	979.081	982.209	mV	156	A
988.465	991.593	994.721	mV	158	A
1000.978	1004.106	1007.234	mV	160	A
1013.490	1016.618	1019.746	mV	162	A

$V_{ICCMAX} = \frac{R2}{R1+R2} \times V_{CC}$				ICCMAX	Unit
Min	Typical	Max	Unit		
1026.002	1029.13	1032.258	mV	164	A
1038.514	1041.642	1044.770	mV	166	A
1051.026	1054.154	1057.283	mV	168	A
1063.539	1066.667	1069.795	mV	170	A
1076.051	1079.179	1082.307	mV	172	A
1088.563	1091.691	1094.819	mV	174	A
1101.075	1104.203	1107.331	mV	176	A
1113.587	1116.716	1119.844	mV	178	A
1126.100	1129.228	1132.356	mV	180	A
1138.612	1141.740	1144.868	mV	182	A
1151.124	1154.252	1157.380	mV	184	A
1163.636	1166.764	1169.892	mV	186	A
1176.149	1179.277	1182.405	mV	188	A
1188.661	1191.789	1194.917	mV	190	A
1201.173	1204.301	1207.429	mV	192	A
1213.685	1216.813	1219.941	mV	194	A
1226.197	1229.326	1232.454	mV	196	A
1238.710	1241.838	1244.966	mV	198	A
1251.222	1254.350	1257.478	mV	200	A
1263.734	1266.862	1269.990	mV	202	A
1276.246	1279.374	1282.502	mV	204	A
1288.759	1291.887	1295.015	mV	206	A
1301.271	1304.399	1307.527	mV	208	A

$V_{ICCMAX} = \frac{R2}{R1+R2} \times V_{CC}$				ICCMAX	Unit
Min	Typical	Max	Unit		
1313.783	1316.911	1320.039	mV	210	A
1326.295	1329.423	1332.551	mV	212	A
1338.807	1341.935	1345.064	mV	214	A
1351.320	1354.448	1357.576	mV	216	A
1363.832	1366.960	1370.088	mV	218	A
1376.344	1379.472	1382.600	mV	220	A
1388.856	1391.984	1395.112	mV	222	A
1401.369	1404.497	1407.625	mV	224	A
1413.881	1417.009	1420.137	mV	226	A
1426.393	1429.521	1432.649	mV	228	A
1438.905	1442.033	1445.161	mV	230	A
1451.417	1454.545	1457.674	mV	232	A
1463.930	1467.058	1470.186	mV	234	A
1476.442	1479.570	1482.698	mV	236	A
1488.954	1492.082	1495.210	mV	238	A
1501.466	1504.594	1507.722	mV	240	A
1513.978	1517.107	1520.235	mV	242	A
1526.491	1529.619	1532.747	mV	244	A
1539.003	1542.131	1545.259	mV	246	A
1551.515	1554.643	1557.771	mV	248	A
1564.027	1567.155	1570.283	mV	250	A
1576.540	1579.668	1582.796	mV	252	A
1589.052	1592.180	1595.308	mV	254	A

### Over Current Protection

RT8884B provides Over Current Protection (OCP) which is set by the SET1 pin. The OCP threshold setting can refer to ICCMAX current in the Table 7. For example, if ICCMAX is set as 120A, user can set voltage by using the external voltage divider in SET1 pin as 0.466V typically if DVID\_Threshold = 35mV, then 144A OCP (120% x ICCMAX) threshold will be set. When output current is higher than the OCP threshold, OCP is latched with a 40μs delay time to prevent false trigger. Besides, the OCP function is masked when dynamic VID transient occurs and after dynamic VID transition, OCP is masked for 80μs.

### Over Output Voltage Protection

An OVP condition is detected when the VSEN pin is 350mV more than VID. When OVP is detected, the upper gate voltage UGATEx is pulled-low and the lower gate voltage LGATEx is pulled-high, OVP is latched with a 0.5μs delay time to prevent false trigger.

### Negative Voltage Protection

Since the OVP latch continuously turns on all low side MOSFETs of the VR, the VR will suffer negative output voltage. When the VSEN detects a voltage below -0.05V after triggering OVP, the VR will trigger NVP to turn off all low side MOSFETs of the VR while the high side MOSFETs remains off. After triggering NVP, if the output voltage rises above 0V, the OVP latch will restart to turn on all low side MOSFETs. Therefore, the output voltage may bounce between 0V and -0.05V due to OVP latch and NVP triggering. The NVP function will be active only after OVP is triggered.

### Under Voltage Protection

When the VSEN pin voltage is 350mV less than VID, a UVP will be latched. When UVP latched, both the UGATEx and LGATEx will be pulled-low. A 3μs delay is used in UVP detection circuit to prevent false trigger. Besides, the UVP function is masked when dynamic VID transient occurs and after dynamic VID transition, UVP is masked for 80μs.

### Under Voltage Lock Out (UVLO)

During normal operation, if the voltage at the VCC or DVD pin drops below POR threshold 4.1V (min), the VR will trigger UVLO. The UVLO protection forces all high side MOSFETs and low side MOSFETs off by shutting down internal PWM logic drivers.

### Power Ready (POR) Detection

During start-up, the RT8884B will detect the voltage at the voltage input pins : VCC, EN and DVD. When VCC > 4.45V and VD<sub>DVD</sub> > 2V, the RT8884B will recognize the power state of system to be ready (POR = high) and wait for enable command at the EN pin. After POR = high and V<sub>EN</sub> > 0.7V, the RT8884B will enter start-up sequence. If the voltage at any voltage pin drops below low threshold (POR = low), the RT8884B will enter power down sequence and all the functions will be disabled. Normally, connecting system voltage V<sub>TT</sub> (1.05V) to the EN pin and power stage VIN (12V, through a voltage divider) to the DVD pin is recommended. 1ms (max) after the chip has been enabled, the SVID circuitry will be ready. All the protection latches (OVP, OCP, UVP) will be cleared only by VCC. The condition of V<sub>EN</sub> = low will not clear these latches. Figure 17 and Figure 18 show the POR detection and the timing chart for POR process, respectively.

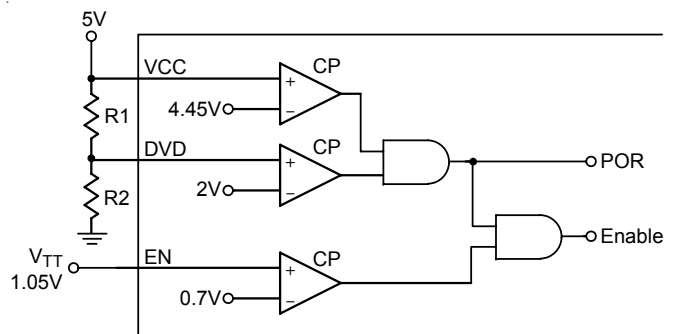

Figure 17. POR Detection

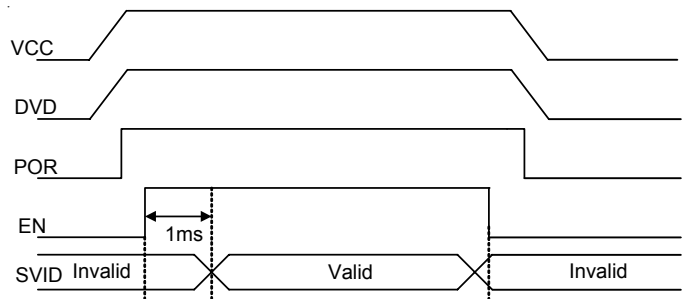

Figure 18. Timing Chart for POR Process

**Precise Reference Current Generation, IBIAS**

Analog circuits need very precise reference voltage/current to drive/set these analog devices. The RT8884B provides a 2V voltage source at the IBIAS pin, and a 100kΩ resistor is required to be connected between the IBIAS pin and analog ground to generate a very precise reference current. Through this connection, the RT8884B will generate a 20μA current from the IBIAS pin to analog ground, and this 20μA current will be mirrored inside the RT8884B for internal use. The IBIAS pin can only be connected with a 100kΩ resistor to GND for internal analog circuit use. The resistance accuracy of this resistor is recommended to be 1% or higher. Figure 19 shows the IBIAS setting circuit.

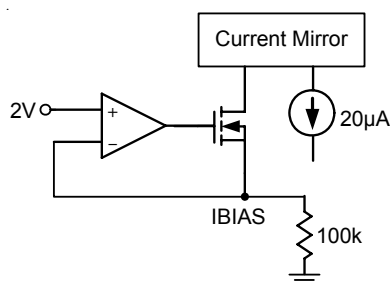

Figure 19. IBIAS Setting Circuit

**TSEN and VR\_HOT**

The VR\_HOT signal is an open-drain signal which is used for VR thermal protection. When the sensed voltage in TSEN pin is over 1.887V, the VR\_HOT signal will be pulled-low to notify CPU that the thermal protection needs to work. According to Intel VR definition, VR\_HOT signal needs acting if VR power chain temperature exceeds 100°C. Placing an NTC thermistor at the hottest area in the VR power chain and its connection is shown in Figure 20, to design the voltage divider elements (R1, R2 and NTC) so that VTSEN = 1.887V at 100°C. The resistance accuracy of TSEN network is recommended to be 1% or higher.

$$V_{TSEN} = V_{CC} \times \frac{R2}{R2 + \left[ R1 // R_{NTC(100^\circ C)} \right]} = 1.887V$$

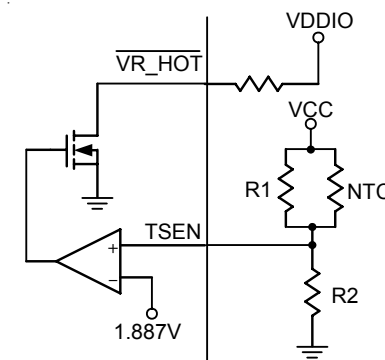

Figure 20. VR\_HOT Circuit

**Differential Remote Sense Setting**

The VR provides differential remote sense inputs to eliminate the effects of voltage drops along the PC board traces, CPU internal power routes and socket contacts. The CPU contains on-die sense pins, VCC\_SENSE and VSS\_SENSE. Connecting RGND to VSS\_SENSE and FB to VCC\_SENSE with a resistor to build the negative input path of the error amplifier. The VDAC and the precision voltage reference are referred to RGND for accurate remote sensing.

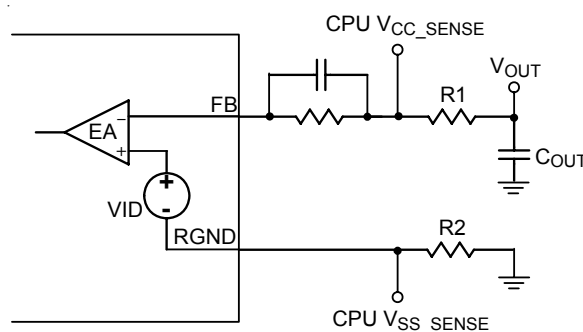

Figure 21. Remote Sensing Circuit

### NO Load Offset (Platform)

RT8884B provides no load offset for platform users. Users can disable this function by pulling the SET3 pin to ground. Figure 22 shows a voltage divider used to set no load offset voltage. No load offset voltage setting is :

$$V_{OFS} = \frac{1}{2} \times (V_{SET3} - 1.2)$$

The range of  $V_{OFS}$  is  $-250mV < V_{OFS} < 600mV$ .

For example, a 100mV no load offset requirement,  $V_{SET3}$  needs to be set as 1.4V.

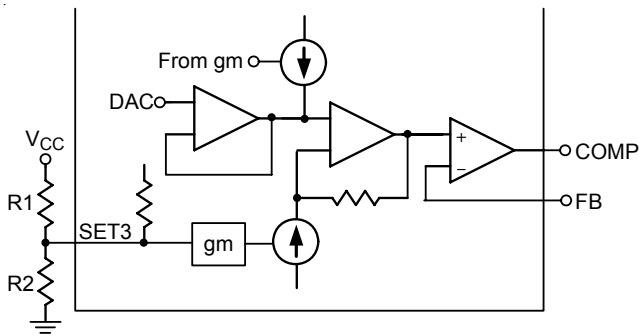

Figure 22. No Load Offset Circuit

### Phase Disable (Before POR)

The number of active phases is determined by the internal circuitry that monitors the ISENxN voltages during start-up. Normally, the VR operates as a 4-phase PWM controller. Pulling ISEN4N to VCC programs a 3-phase operation, pulling ISEN3N and ISEN4N to VCC programs a 2-phase operation, and pulling ISEN2N, ISEN3N and ISEN4N to VCC programs a 1-phase operation. Before POR, VR detects whether the voltages of ISEN2N, ISEN3N and ISEN4N are higher than "VCC-1V" respectively to decide how many phases should be active. Phase selection is only active during POR. When POR = high, the number of active phases is determined and latched. The unused ISENxP pins are recommended to be connected to VCC and unused PWM pins can be left floating.

Current Loop Design in Details

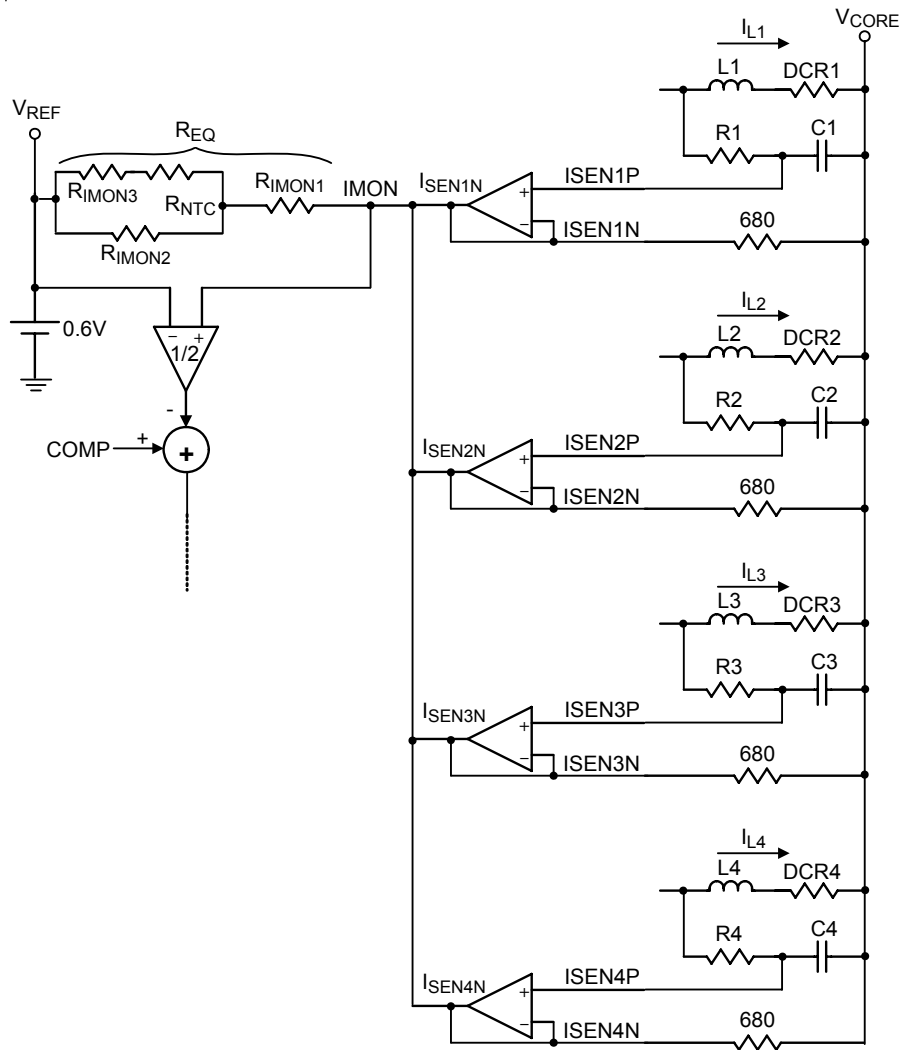

Figure 23. Current Loop Structure

Figure 23 shows the whole current loop structure. The current loop plays an important role in RT8884B that can decide ACLL performance, DCLL accuracy and ICCMAX accuracy. For ACLL performance, the correct compensator design is assumed, if RC network time constant matches inductor time constant  $L_x/DCR_x$ , an expected load transient waveform can be designed. If  $R_xC_x$  network time constant is larger than inductor time constant  $L_x/DCR_x$ ,  $V_{CORE}$  waveform has a sluggish droop during load transient. If

$R_xC_x$  network is smaller than inductor time constant  $L_x/DCR_x$ , a worst  $V_{CORE}$  waveform will sag to create an undershoot to fail the specification. Figure 24 shows the variety of  $R_xC_x$  constant corresponding to the output waveforms.

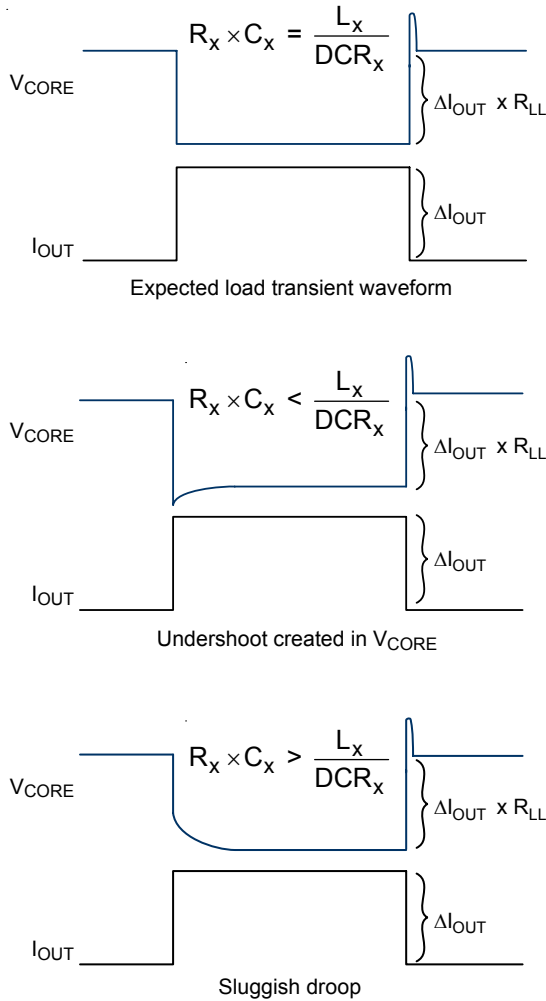

Figure 24. All Kind of  $R_x C_x$  Constants

For DCLL performance and ICCMAX accuracy, since the copper wire of inductor has a positive temperature coefficient, hence when temperature goes high in the heavy load condition then DCR value goes large simultaneously. A resistor network with NTC thermistor compensation connecting between IMON pin and REF pin is necessary, to compensate the positive temperature coefficient of inductor DCR. The design flow is as follows:

Step1 : Given the three system temperature  $T_L$ ,  $T_R$  and  $T_H$ , at which are compensated.

Step2 : Three equations can be listed as

$$\frac{DCR(T_L)}{680} \times \sum_{i=1}^4 I_{Li} \times R_{EQ}(T_L) = 1.6$$

$$\frac{DCR(T_R)}{680} \times \sum_{i=1}^4 I_{Li} \times R_{EQ}(T_R) = 1.6$$

$$\frac{DCR(T_H)}{680} \times \sum_{i=1}^4 I_{Li} \times R_{EQ}(T_H) = 1.6$$

Where :

(1) The relationship between DCR and temperature is as follows :

$$DCR(T) = DCR(25^\circ C) \times [1 + 0.00393(T - 25)]$$

(2)  $R_{EQ}(T)$  is the equivalent resistor of the resistor network with a NTC thermistor

$$R_{EQ}(T) = R_{IMON1} + \{R_{IMON2} // [R_{IMON3} + R_{NTC}(T)]\}$$

And the relationship between NTC and temperature is as follows :

$$R_{NTC}(T) = R_{NTC}(25^\circ C) \times e^{\beta \left( \frac{1}{T+273} - \frac{1}{298} \right)}$$

$\beta$  is in the NTC thermistor datasheet.

Step3 : Three equations and three unknowns,  $R_{IMON1}$ ,  $R_{IMON2}$  and  $R_{IMON3}$  can be found out unique solution.

$$R_{IMON1} = K_{TR} - \frac{R_{IMON2} \times (R_{NTCTR} + R_{IMON3})}{R_{IMON2} + R_{NTCTR} + R_{IMON3}}$$

$$R_{IMON2} = \sqrt{[K_{R3}^2 + K_{R3}(R_{NTCTL} + R_{NTCTR}) + R_{NTCTL}R_{NTCTR}] \alpha_{TL}}$$

$$R_{IMON3} = -R_{IMON2} + K_{R3}$$

Where :

$$\alpha_{TH} = \frac{K_{TH} - K_{TR}}{R_{NTCTH} - R_{NTCTR}}$$

$$\alpha_{TL} = \frac{K_{TL} - K_{TR}}{R_{NTCTL} - R_{NTCTR}}$$

$$K_{R3} = \frac{(\alpha_{TH} / \alpha_{TL}) R_{NTCTH} - R_{NTCTL}}{1 - (\alpha_{TH} / \alpha_{TL})}$$

$$K_{TL} = \frac{1.6}{G_{CS(TL)} \times I_{CC-MAX}}$$

$$K_{TR} = \frac{1.6}{G_{CS(TR)} \times I_{CC-MAX}}$$

$$K_{TH} = \frac{1.6}{G_{CS(TH)} \times I_{CC-MAX}}$$

**Design Step :**

RT8884B Excel based design tool is available. Users can contact your Richtek representative to get the spreadsheet. Three main design procedures for RT8884B design, first step is initial settings, second step is loop design and the last step is protection settings. The following design example is to explain RT8884B design procedure :

	<b>V<sub>CORE</sub> Specification</b>
Input Voltage	12V
No. of Phases	3
Vboot	1.7V
V <sub>DAC(MAX)</sub>	1.85V
ICCMAX	90A
ICC-DY	60A
ICC-TDC	55A
Load-Line	1.5mΩ
Fast Slew Rate	12.5mV/μs
Max Switching Frequency	300kHz

In Shark Bay VRTB Guideline, the output filter requirements of VRTB specification for desktop platform are as follows :

Output Inductor : 360nH/0.72mΩ

Output Bulk Capacitor : 560μF/2.5V/5mΩ (max) 4 to 5pcs

Output Ceramic Capacitor : 22μF/0805 (18pcs max sites on top side)

(1)Initial Settings :

- RT8884B initial voltage is 1.7V
- IBIASE needs to connect a 100kΩ resistor to ground.
- A voltage divider for setting DVD can choose R<sub>DVD\_U</sub> = 510kΩ and R<sub>DVD\_L</sub> = 125kΩ to set V<sub>DVD</sub> > 2V, RT8884B enabled.

(2)Loop Design :

- On time setting : Using the specification, T<sub>ON</sub> is

$$t_{ON} = \frac{1}{f_{SW(MAX)}} \times \frac{V_{DAC(MAX)}}{V_{IN}} = 514n(s)$$

The on time setting resistor R<sub>TON</sub> = 130kΩ

- Current sensor adopts lossless RC filter to sense current signal in DCR. For getting an expected load transient waveform, R<sub>x</sub>C<sub>x</sub> time constant needs to match L<sub>x</sub>/DCR<sub>x</sub> per phase. C<sub>x</sub> = 1μF is set, then

$$R_X = \frac{L_X}{1\mu F \times DCR_X} = 500\Omega$$

- IMON resistor network design : T<sub>L</sub> = 25°C, T<sub>R</sub> = 50°C and T<sub>H</sub> = 100°C are decided, NTC thermistor = 100kΩ @25°C, β = 4485 and ICCMAX = 90A. According to the sub-section "Current Loop Design in Details", R<sub>IMON1</sub> = 5.43kΩ, R<sub>IMON2</sub> = 12.6kΩ and R<sub>IMON3</sub> = 13.9kΩ can be decided. The R<sub>EQ</sub>(25°C) = 16.8kΩ.

- Load-line design : 1.5mΩ droop is required, because R<sub>EQ</sub>(25°C) is decided, the voltage loop Av gain is also decided by the following equation :

$$R_{LL} = \frac{A_V}{A_I} = \frac{\frac{1}{2} \times \frac{DCR}{R_{CS}} \times R_{EQ}}{\frac{R_2}{R_1}} \quad (m\Omega)$$

Where DCR(25°C) = 0.72mΩ, R<sub>CS</sub> = 680Ω and R<sub>EQ</sub>(25°C) = 16.8kΩ. Hence the A<sub>V</sub> = R<sub>2</sub> / R<sub>1</sub> = 5.92 can be obtained. R<sub>1</sub> = 10kΩ usually is decided, so R<sub>2</sub> = 59.2kΩ.

- Typical compensator design can use the following equations to design the C<sub>1</sub> and C<sub>2</sub> values

$$C_1 = \frac{1}{R_1 \times \pi \times f_{SW}} \approx 106pF$$

$$C_2 = \frac{C_{OUT} \times ESR}{R_2} \approx 79pF$$

For Intel platform, in order to induce the band width to enhance transient performance to meet Intel's criterion, the compensator of Zero can be designed close to 1/10 of switching frequency.

- SET1 resistor network design : First the DVID compensation parameters need to be decided. The DVID\_TH can be calculated as the following equation :

$$V_{DVID\_TH} = LL \times C_{OUT} \times \frac{dVID}{dt}$$

Where LL is load-line, C<sub>OUT</sub> is total output capacitance and dVID/dt is DVID fast slew rate. Thus V<sub>DVID\_TH</sub> = 45mV is needed in this case. And DVID\_Width is chosen as 72μs typically. Next, OCP threshold is designed as 1.4 x ICCMAX. Last, RAMP = R<sub>TON</sub> / 130kΩ = 100%, 100% is

set. By using above information, the two equations can be listed by using multi-function pin setting mechanism

$$0.286 = \frac{R2}{R1+R2} \times 5$$

$$0.737 = 80\mu A \times \left( \frac{R1 \times R2}{R1+R2} \right)$$

R1 = 160kΩ, R2 = 9.77kΩ.

- SET2 resistor network design : the QR mechanism parameters need to be designed first. Initial QR\_TH is designed as 0.4 x LL x ICC-DY = 36mV and QR\_Width is designed as 1.11 x T<sub>ON</sub>. The ICCMAX is designed as 90A. By using the information, the two equations can be listed by using multi-function pin setting mechanism

$$0.566 = \frac{R2}{R1+R2} \times 5$$

$$0.686 = 80\mu A \times \left( \frac{R1 \times R2}{R1+R2} \right)$$

R1 = 75.8kΩ, R2 = 9.68kΩ.

- No load offset function disabled. Just connect a 0Ω resistor from SET3 pin to ground.

### (3) Protection Settings :

- OVP/UVLP protections : When V<sub>SEN</sub> pin voltage is 350mV more than VID, the OVP will be latched. When V<sub>SEN</sub> pin voltage is 350mV less than VID, the UVP will be latched.
- TSEN and VR\_HOT design : Using the following equation to calculate related resistances for VR\_HOT setting.

$$V_{TSEN} = V_{CC} \times \frac{R2}{R2 + [R_{NTC(100^\circ C)} // R1]} = 1.887V$$

Choosing R1 = 100kΩ and an NTC thermistor R<sub>NTC</sub>(25°C) = 100kΩ which its β = 4485. When temperature is 100°C, the R<sub>NTC</sub>(100°C) = 4.85kΩ. Then R<sub>2</sub> = 2.8kΩ can be calculated.

### Thermal Considerations

For continuous operation, do not exceed absolute maximum junction temperature. The maximum power dissipation depends on the thermal resistance of the IC package, PCB layout, rate of surrounding airflow, and difference between junction and ambient temperature. The maximum power dissipation can be calculated by the following formula :

$$P_{D(MAX)} = (T_{J(MAX)} - T_A) / \theta_{JA}$$

where T<sub>J(MAX)</sub> is the maximum junction temperature, T<sub>A</sub> is the ambient temperature, and θ<sub>JA</sub> is the junction to ambient thermal resistance.

For recommended operating condition specifications, the maximum junction temperature is 125°C. The junction to ambient thermal resistance, θ<sub>JA</sub>, is layout dependent. For WQFN-32L 4x4 package, the thermal resistance, θ<sub>JA</sub>, is 27.8°C/W on a standard JEDEC 51-7 four-layer thermal test board. The maximum power dissipation at T<sub>A</sub> = 25°C can be calculated by the following formula :

$$P_{D(MAX)} = (125^\circ C - 25^\circ C) / (27.8^\circ C/W) = 3.6W \text{ for WQFN-32L 4x4 package}$$

The maximum power dissipation depends on the operating ambient temperature for fixed T<sub>J(MAX)</sub> and thermal resistance, θ<sub>JA</sub>. The derating curve in Figure 25 allows the designer to see the effect of rising ambient temperature on the maximum power dissipation.

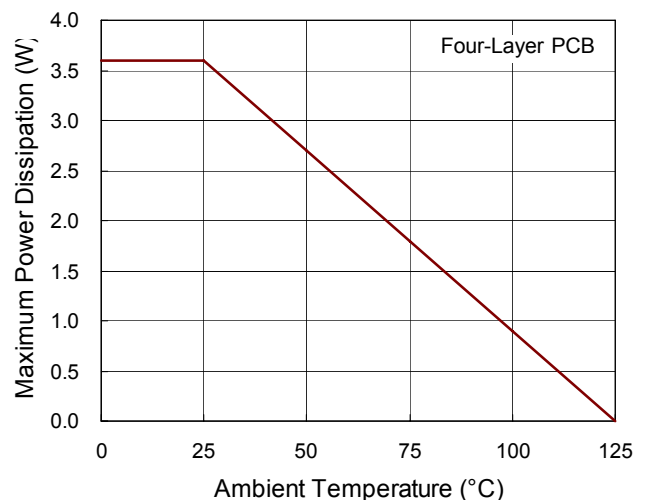

Figure 25. Derating Curve of Maximum Power Dissipation

### Layout Considerations

Careful PC board layout is critical to achieve low switching losses and clean, stable operation. The switching power stage requires particular attention. If possible, mount all of the power components on the top side of the board with their ground terminals flushed against one another. Follow these guidelines for optimum PC board layout :

- ▶ Keep the high current paths short, especially at the ground terminals.
- ▶ Keep the power traces and load connections short. This is essential for high efficiency.
- ▶ When trade-offs in trace lengths must be made, it's preferable to let the inductor charging path be longer than the discharging path.
- ▶ Place the current sense component close to the controller. ISENxP and ISENxN connections for current limit and voltage positioning must be made using Kelvin sense connections to guarantee current sense accuracy. The PCB trace from the sense nodes should be paralleled back to the controller.
- ▶ Route high speed switching nodes away from sensitive analog areas (COMP, FB, ISENxP, ISENxN, etc...)
- ▶ User need to connect exposed pad to the ground plane through low impedance path. Recommend use of at least 5 vias to connect to ground planes in PCB internal layers.

Outline Dimension

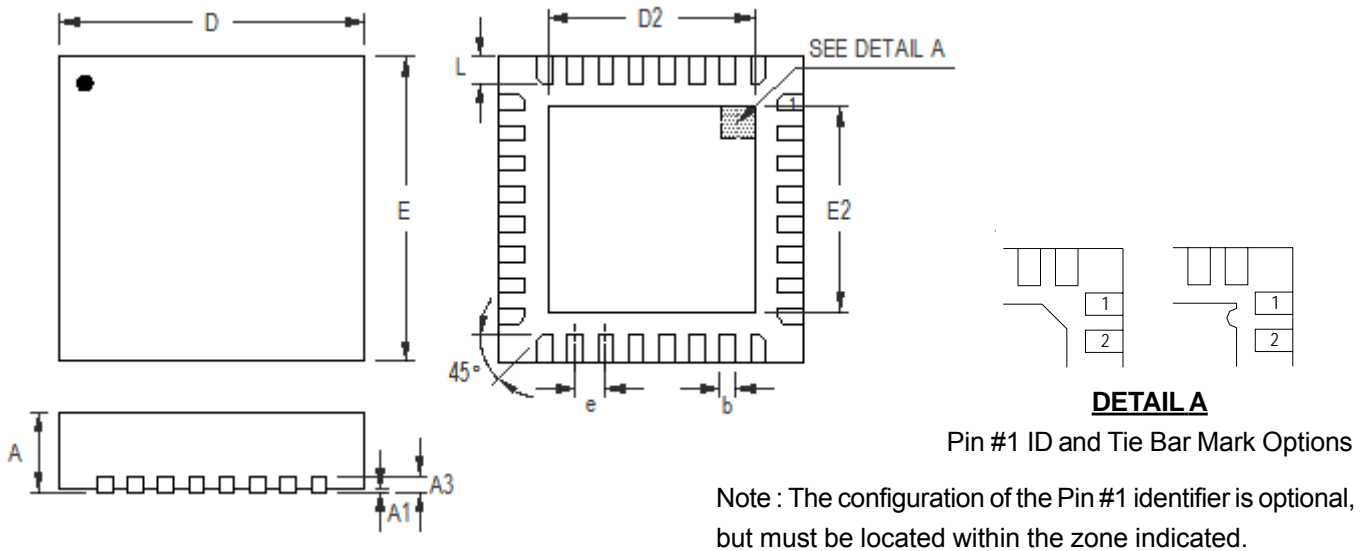

Symbol	Dimensions In Millimeters		Dimensions In Inches	
	Min	Max	Min	Max
A	0.700	0.800	0.028	0.031
A1	0.000	0.050	0.000	0.002
A3	0.175	0.250	0.007	0.010
b	0.150	0.250	0.006	0.010
D	3.900	4.100	0.154	0.161
D2	2.650	2.750	0.104	0.108
E	3.900	4.100	0.154	0.161
E2	2.650	2.750	0.104	0.108
e	0.400		0.016	
L	0.300	0.400	0.012	0.016

W-Type 32L QFN 4x4 Package

**Richtek Technology Corporation**

14F, No. 8, Tai Yuen 1<sup>st</sup> Street, Chupei City  
 Hsinchu, Taiwan, R.O.C.  
 Tel: (8863)5526789

Richtek products are sold by description only. Richtek reserves the right to change the circuitry and/or specifications without notice at any time. Customers should obtain the latest relevant information and data sheets before placing orders and should verify that such information is current and complete. Richtek cannot assume responsibility for use of any circuitry other than circuitry entirely embodied in a Richtek product. Information furnished by Richtek is believed to be accurate and reliable. However, no responsibility is assumed by Richtek or its subsidiaries for its use; nor for any infringements of patents or other rights of third parties which may result from its use. No license is granted by implication or otherwise under any patent or patent rights of Richtek or its subsidiaries.



## Looking for pricing, stock, or lifecycle information?

Click below to explore more details on WIN SOURCE:

 [View RT8884BGQW on WIN SOURCE](#)

 [Richtek USA Inc. Information](#)

## Optimize Your Supply Chain with WIN SOURCE Solutions

-  Global Sourcing Solution
-  Obsolete Management
-  Cost Control Management
-  Shortage Management
-  Alternative Solution
-  Excess Inventory Management