



THE DATASHEET OF GWS4621L



GWS4621L

Dual 20V N-Channel Power MOSFET

FN8784
Rev.2.00
Jun 20, 2017

The GWS4621L is a dual 20V, 8.8mΩ, N-channel power MOSFET used for Li-ion battery protection. It is offered in a 1.85mmx1.85mm LGA with a very low thickness profile, 0.29mm typical thickness. It has extremely high power density, reducing the board size of the Li-ion battery power system. Designed for handheld devices with a high level of ESD protection.

PRODUCT SUMMARY			
$V_{(BR)SSS}$	$I_D = 250\mu A$	20V	Minimum
$r_{DS(ON)}$	$V_{GS} = 4.5V$	8.8mΩ	Typical

Features

- Monolithic dual MOSFET
- Low $r_{DS(ON)}$ in a small footprint
- Ultra low gate charge and figure of merit
- LGA chip scale package
- Low thermal resistance

Applications

- Li-ion battery protection
- Portable devices, cell phones, PDA
- Rated for short-circuit and overcurrent protection
- Integrated G-S diodes provide ESD protection of 2.5kV HBM

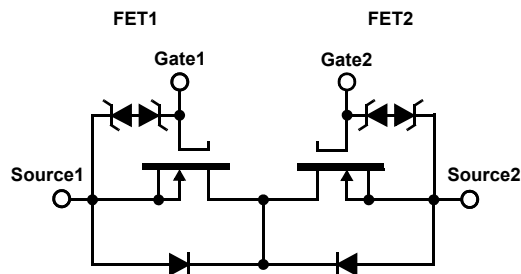

FIGURE 1. EQUIVALENT CIRCUIT

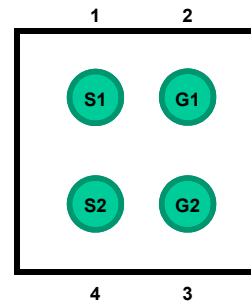
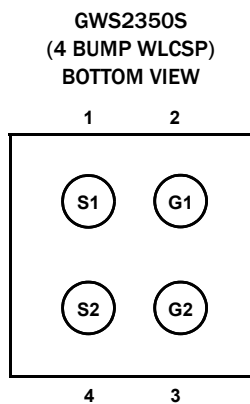

FIGURE 2. PAD VIEW, 1.815mm x 1.815mm

Ordering Information

PART NUMBER	PART MARKING	TEMP RANGE (°C)	PACKAGE (RoHS Compliant)
GWS4621L	21	-55 to +150	4 BUMP WLCSP

Pin Configuration



Pin Descriptions

PIN #	PIN NAME	DESCRIPTION
1	S1	Source of FET1
2	G1	Gate of FET1
3	G2	Gate of FET2
4	S2	Source of FET2

Absolute Maximum Ratings (Note 1)

Source-to-Source Voltage (V_{DS})	-20V
Gate-to-Source Voltage (V_{GS})	$\pm 8V$
Source Current (I_S) (Note 2)	
$T_A = +25^\circ C$	10.1A (10s), 6.5A (Steady State)
$T_A = +70^\circ C$	8.1A (10s), 5.2A (Steady State)
Source Current (RthjFoot) $T_F = +25^\circ C$	1.5A (Steady State)
Pulsed Source Current (I_{SM})	60A
ESD Rating	
Human Body Model	2.5kV

Thermal Information

Thermal Resistance (Typical)	θ_{JA} ($^\circ C/W$)	θ_{JF} ($^\circ C/W$)
$t \leq 10s$	35	
Steady State	85	16
Maximum Power Dissipation (P_D) (Note 2)		
$T_A = +25^\circ C$	3.6W (10s) 1.47W (Steady State)	
$T_A = +70^\circ C$	2.29W (10s) 0.94W (Steady State)	
Junction and Storage Temperature Range (T_J, T_{stg})	-55 $^\circ C$ to +150 $^\circ C$	
Pb-Free Reflow Profile	see TB493	

CAUTION: Do not operate at or near the maximum ratings listed for extended periods of time. Exposure to such conditions may adversely impact product reliability and result in failures not covered by warranty.

NOTES:

1. $T_J = +25^\circ C$ unless otherwise noted.
2. Surface mounted on FR4 board.

Electrical Characteristics $T_J = +25^\circ C$ unless otherwise noted.

SYMBOL	PARAMETER	TEST CONDITIONS	MIN (Note 3)	TYP (Note 4)	MAX (Note 3)	UNIT	
STATIC							
$V_{(BR)SSS}$	Source-to-Source Breakdown Voltage	$V_{GS} = 0V, I_D = 250\mu A$	20			V	
I_{SSS}	Zero Gate Voltage Source Current	$V_{GS} = 0V, V_{DS} = 20V$			1	μA	
I_{GSS}	Gate Body Leakage	$V_{DS} = 0V, V_{GS} = \pm 6V$			± 10	μA	
$V_{GS(th)}$	Gate Threshold Voltage	$V_{DS} = V_{GS}, I_D = 1mA$	0.5	0.8	1.5	V	
$r_{DS(ON)}$	Drain-to-Source On-State Resistance (Note 5)	$V_{GS} = 4.5V, I_D = 3A$	6.0	8.8	9.8	m Ω	
		$V_{GS} = 4.0V, I_D = 3A$	7.0	9.0	10.3	m Ω	
		$V_{GS} = 3.1V, I_D = 3A$	8.0	10.0	12.0	m Ω	
		$V_{GS} = 2.5V, I_D = 3A$	9.0	11.5	13.5	m Ω	
$r_{SS(ON)}$	Source-to-Source On-State Resistance (Note 5)	$V_{GS} = 4.5V, I_S = 3A$	$T_J = +25^\circ C$	12.0	17.5	19.5	m Ω
			$T_J = +50^\circ C$	12.0	21.0	23.0	m Ω
		$V_{GS} = 4.0V, I_S = 3A$	$T_J = +25^\circ C$	14.0	18.0	20.5	m Ω
			$T_J = +50^\circ C$	14.0	22.0	24.0	m Ω
		$V_{GS} = 3.1V, I_S = 3A$	$T_J = +25^\circ C$	16.0	20.0	24.0	m Ω
			$T_J = +50^\circ C$	16.0	23.0	27.0	m Ω
V_{SS}	Source-to-Source Diode Voltage	$V_{GS} = 0, I_S = 6.5A$	$T_J = +25^\circ C$	0.8	1.0	V	
			$T_J = +50^\circ C$				
DYNAMIC							
Q_g	Total Gate Charge	$V_{SS} = 10V, I_S = 5.0A, V_{GS} = 4.0V$		11		nC	
C_{iss}	Input Capacitance	$V_{SS} = 10V, V_{GS} = 0V, f = 1MHz$		1125		pF	
C_{oss}	Output Capacitance			375		pF	
C_{rss}	Reverse Transfer Capacitance			188		pF	

NOTES:

3. Compliance to datasheet limits is assured by one or more methods: production test, characterization, and/or design.
4. Typical values are for $T_A = +25^\circ C$.
5. Good Kelvin measurement required.

Test Circuit Examples for Measuring FET1 Key Parameters

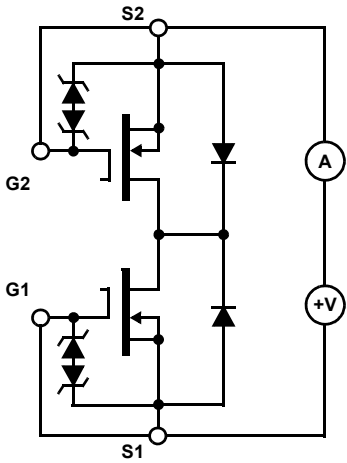

FIGURE 3. I_{SSS} TEST CIRCUIT

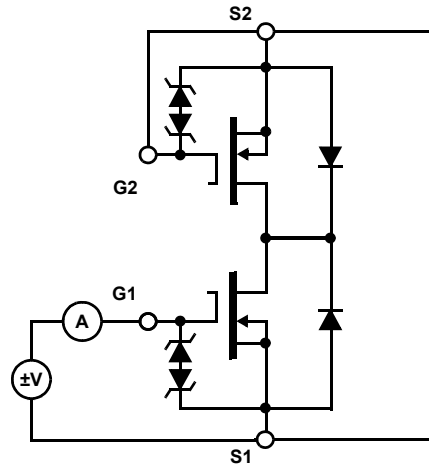

FIGURE 4. I_{GSS} TEST CIRCUIT

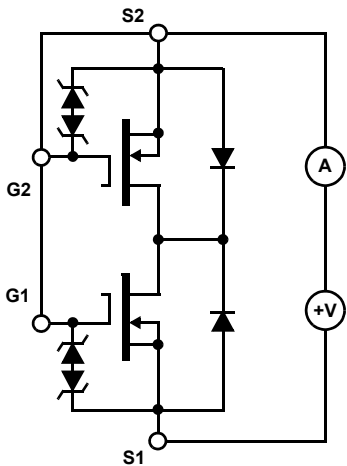

FIGURE 5. $V_{GS(th)}$ TEST CIRCUIT

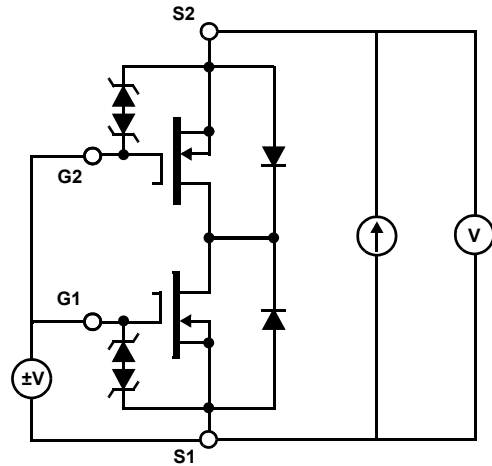

FIGURE 6. $r_{SS(ON)}$ TEST CIRCUIT

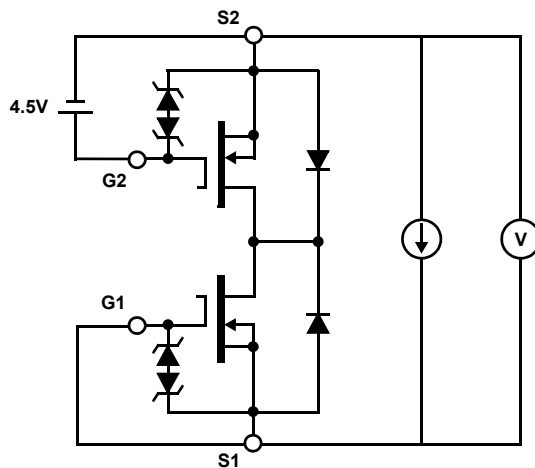

FIGURE 7. V_{FS-S} TEST CIRCUIT

Typical Performance Curves

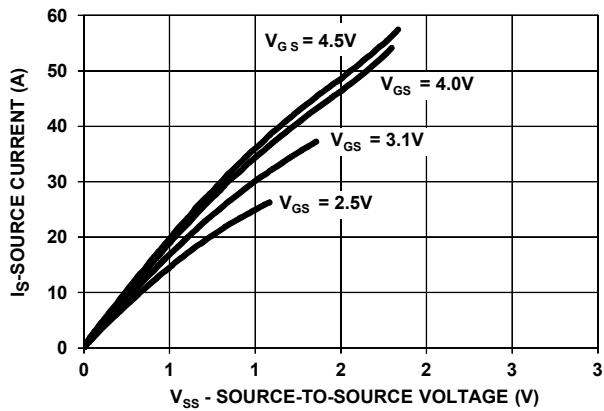

FIGURE 8. OUTPUT CHARACTERISTICS

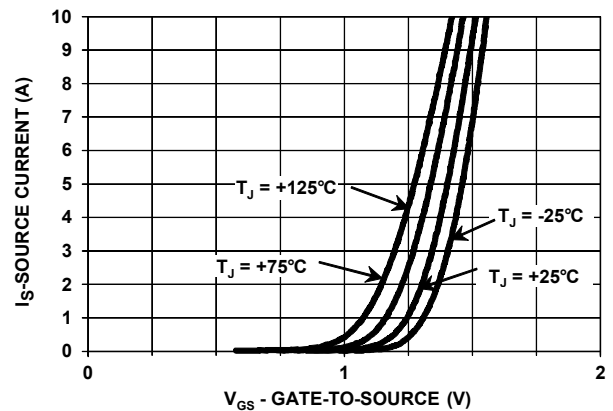

FIGURE 9. TRANSFER CHARACTERISTICS

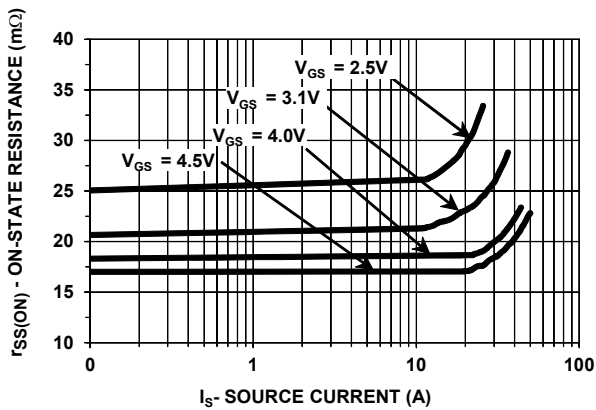

FIGURE 10. SOURCE-TO-SOURCE ON-STATE RESISTANCE vs SOURCE CURRENT

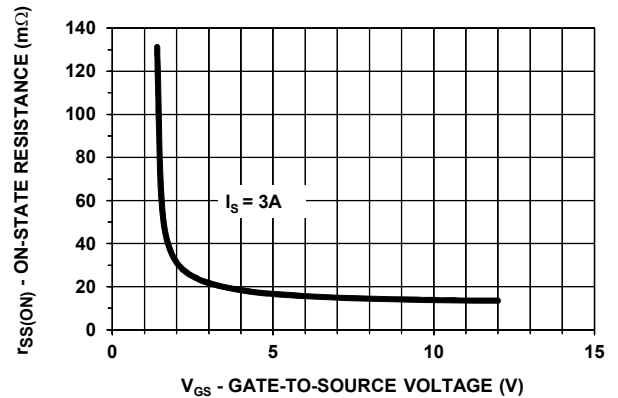

FIGURE 11. SOURCE-TO-SOURCE ON-STATE RESISTANCE vs GATE-TO-SOURCE VOLTAGE

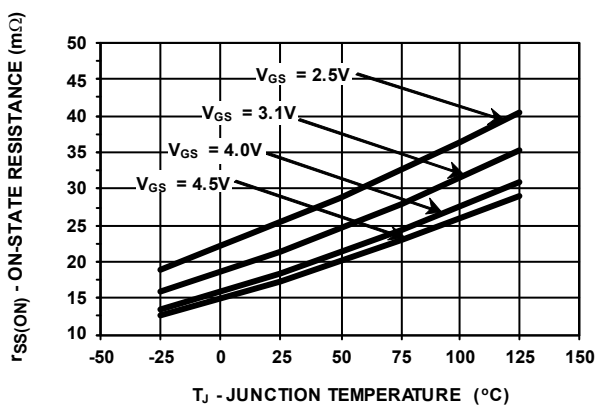

FIGURE 12. SOURCE-TO-SOURCE ON-STATE RESISTANCE vs JUNCTION TEMPERATURE

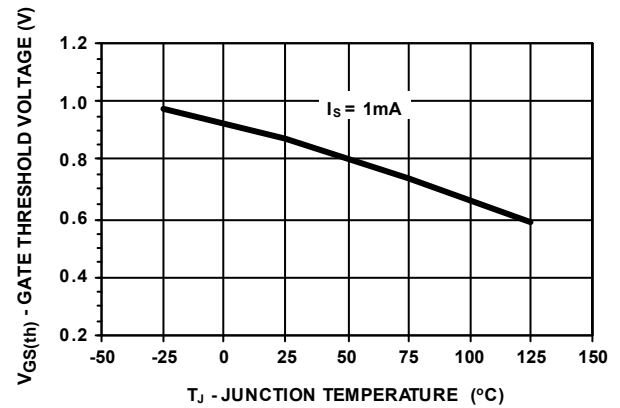

FIGURE 13. GATE THRESHOLD VOLTAGE vs JUNCTION TEMPERATURE

Typical Performance Curves (Continued)

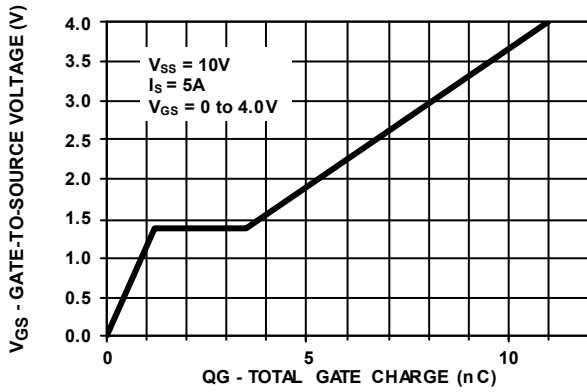

FIGURE 14. GATE CHARGE

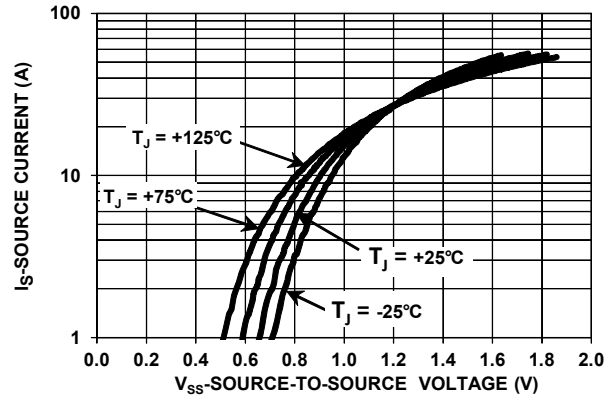

FIGURE 15. SOURCE-TO-SOURCE DIODE FORWARD VOLTAGE

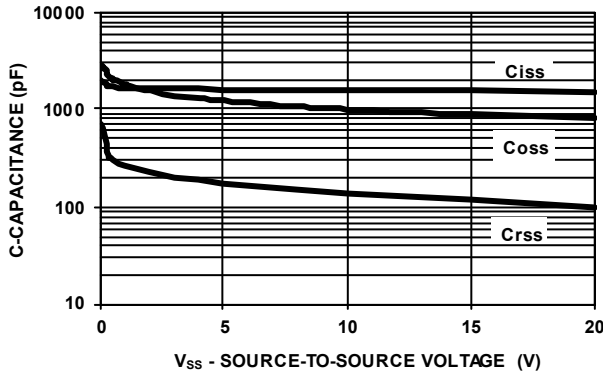

FIGURE 16. CAPACITANCE

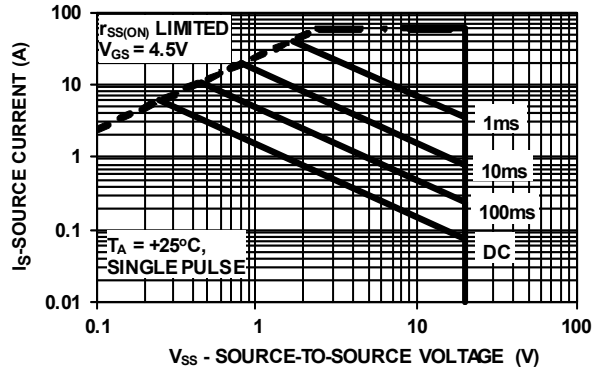

FIGURE 17. MAXIMUM RATED FORWARD BIASED SAFE OPERATING AREA

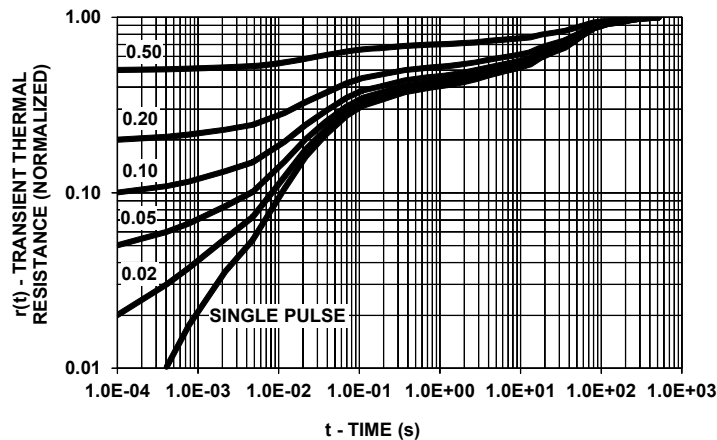

FIGURE 18. TRANSIENT THERMAL RESPONSE, JUNCTION-TO-AMBIENT

Revision History

The revision history provided is for informational purposes only and is believed to be accurate, but not warranted. Please visit our website to make sure that you have the latest revision.

DATE	REVISION	CHANGE
Jun 20, 2017	FN8784.2	Applied new header/footer. Updated About Intersil section.
Dec 21, 2015	FN8784.1	Added "Note 1. $T_J = +25^\circ\text{C}$ unless otherwise noted." to Abs Max on page 3.
Oct 30, 2015	FN8784.0	Initial release

About Intersil

Intersil Corporation is a leading provider of innovative power management and precision analog solutions. The company's products address some of the largest markets within the industrial and infrastructure, mobile computing, and high-end consumer markets. For the most updated datasheet, application notes, related documentation, and related parts, see the respective product information page found at www.intersil.com.

For a listing of definitions and abbreviations of common terms used in our documents, visit www.intersil.com/glossary.

You can report errors or suggestions for improving this datasheet by visiting www.intersil.com/ask.

Reliability reports are also available from our website at www.intersil.com/support.

© Copyright Intersil Americas LLC 2015-2017. All Rights Reserved.
All trademarks and registered trademarks are the property of their respective owners.

For additional products, see www.intersil.com/en/products.html

Intersil products are manufactured, assembled and tested utilizing ISO9001 quality systems as noted in the quality certifications found at www.intersil.com/en/support/qualandreliability.html

Intersil products are sold by description only. Intersil may modify the circuit design and/or specifications of products at any time without notice, provided that such modification does not, in Intersil's sole judgment, affect the form, fit or function of the product. Accordingly, the reader is cautioned to verify that datasheets are current before placing orders. Information furnished by Intersil is believed to be accurate and reliable. However, no responsibility is assumed by Intersil or its subsidiaries for its use; nor for any infringements of patents or other rights of third parties which may result from its use. No license is granted by implication or otherwise under any patent or patent rights of Intersil or its subsidiaries.

For information regarding Intersil Corporation and its products, see www.intersil.com

Outline Drawing (Unit: mm)

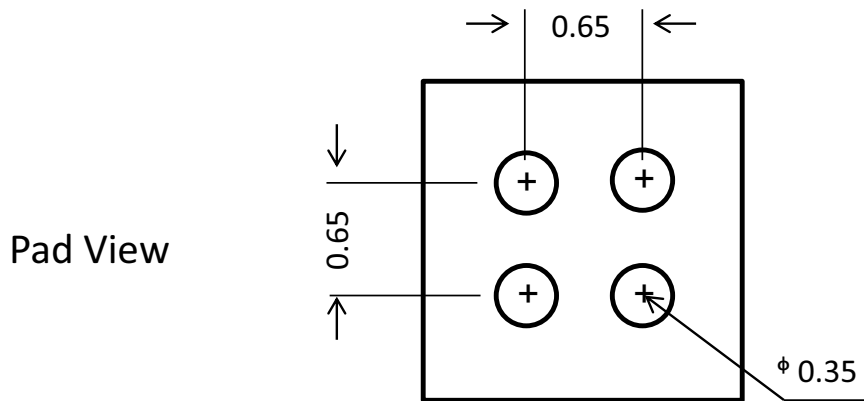
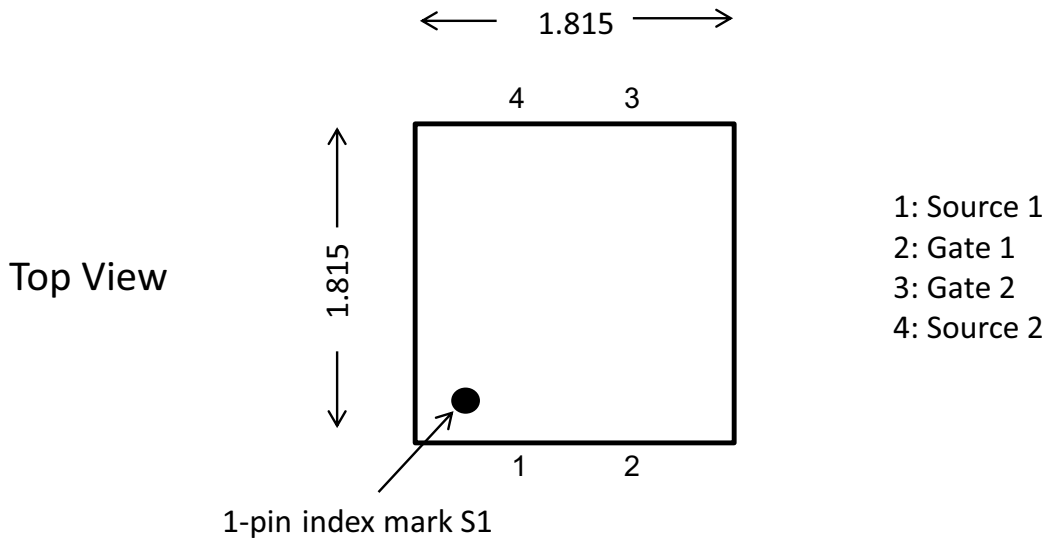

© Copyright Intersil Americas LLC 2015-2017. All Rights Reserved.
 All trademarks and registered trademarks are the property of their respective owners.

For additional products, see www.intersil.com/en/products.html



Intersil products are manufactured, assembled and tested utilizing ISO9001 quality systems as noted in the quality certifications found at www.intersil.com/en/support/qualandreliability.html

Intersil products are sold by description only. Intersil may modify the circuit design and/or specifications of products at any time without notice, provided that such modification does not, in Intersil's sole judgment, affect the form, fit or function of the product. Accordingly, the reader is cautioned to verify that datasheets are current before placing orders. Information furnished by Intersil is believed to be accurate and reliable. However, no responsibility is assumed by Intersil or its subsidiaries for its use; nor for any infringements of patents or other rights of third parties which may result from its use. No license is granted by implication or otherwise under any patent or patent rights of Intersil or its subsidiaries.

For information regarding Intersil Corporation and its products, see www.intersil.com

Looking for pricing, stock, or lifecycle information?

Click below to explore more details on WIN SOURCE:

-  [View GWS4621L on WIN SOURCE](#)
-  [Renesas Electronics America](#) Information

Optimize Your Supply Chain with WIN SOURCE Solutions

-  Global Sourcing Solution
-  Obsolete Management
-  Cost Control Management
-  Shortage Management
-  Alternative Solution
-  Excess Inventory Management