



**THE DATASHEET OF
PI3USB102EZLE+DMX**



PI3USB102E

USB 2.0 High-Speed (480 Mbps) Switch with 5V Protection

Features

- USB 2.0 Compliant (high speed, full speed, and low speed)
- RON: 4.0Ω typical @ VDD = 3.0V
- Channel On Capacitance: 6.0pF
- Wide -3dB Bandwidth: 1,000MHz
- Low Bit-to-bit Skew
- Low Crosstalk: -29B @ 480 Mbps
- Off Isolation: -28dB @ 480 Mbps
- Near-Zero Propagation Delay: 250ps
- Supports 1.8V logic on control pins
- VDD Operating Range: 3.0V to 5.5V
- ESD Y+/Y-: HBM 8kV, CDM 1kV
- ESD for pins other than Y+/Y-: HBM 4kV, CDM 1kV
- Y+/Y- pins have over-voltage protection and can tolerate a short to VBUS
- Totally Lead-Free & Fully RoHS Compliant (Notes 1 & 2)
- Halogen and Antimony Free. "Green" Device (Note 3)
- For automotive applications requiring specific change control (i.e. parts qualified to AEC-Q100/101/104/200, PPAP capable, and manufactured in IATF 16949 certified facilities), please [contact us](mailto:contact@diodes.com) or your local Diodes representative.
<https://www.diodes.com/quality/product-definitions/>
- Packaging (Pb-free & Green):
 - 10-contact TQFN, 1.3mm x 1.6mm x 0.75mm (ZL)

Truth Table

SEL	\overline{OE}	Y+	Y-
X	H	Hi-Z	Hi-Z
L	L	M+	M-
H	L	D+	D-

Description

The DIODES™ PI3USB102E is a single differential channel 2:1 multiplexer/demultiplexer USB 2.0 Switch. Industry leading advantages include a propagation delay of 250ps, resulting from its low channel resistance and I/O capacitance. PI3USB102E is bidirectional and offers very little attenuation of high-speed signals. It is designed for low bit-to-bit skew, high channel-to-channel noise isolation and is compatible with various standards, such as High Speed USB 2.0 (480 Mb/s).

The PI3USB102E offers over voltage protection for the Y+/Y- pins as per the USB 2.0 specification. With the chip powered on or off if Y+/Y- pins are shorted to VBUS (5V +/- 5%), M+/M- and D+/D- outputs are clamped to provide voltage protection for downstream devices.

Application

- Routes signals for USB 2.0
- PC, Notebooks and Hand-held devices

Block Diagram

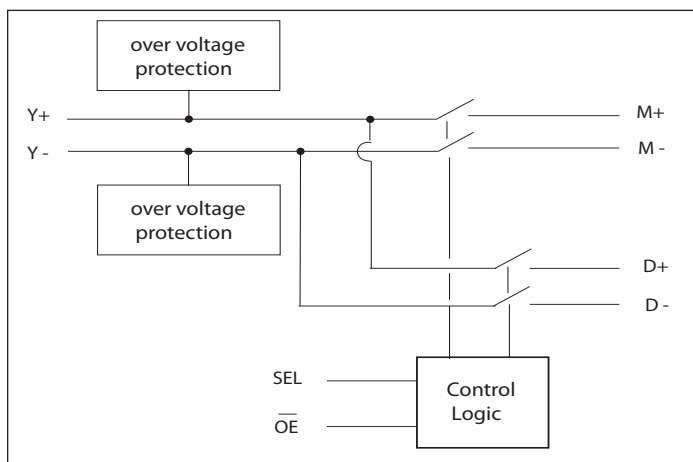

Notes:

1. No purposely added lead. Fully EU Directive 2002/95/EC (RoHS), 2011/65/EU (RoHS 2) & 2015/863/EU (RoHS 3) compliant.
2. See <https://www.diodes.com/quality/lead-free/> for more information about Diodes Incorporated's definitions of Halogen- and Antimony-free, "Green" and Lead-free.
3. Halogen- and Antimony-free "Green" products are defined as those which contain <900ppm bromine, <900ppm chlorine (<1500ppm total Br + Cl) and <1000ppm antimony compounds.

DIODES is a trademark of Diodes Incorporated in the United States and other countries.
The Diodes logo is a registered trademark of Diodes Incorporated in the United States and other countries.

Pin Configuration

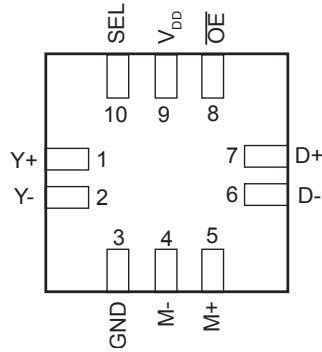

Pin Description

Pin#	Pin Name	Description
1	Y+	USB Data bus
2	Y-	USB Data bus
3	GND	Ground
4	M-	Multiplexed Source Inputs
5	M+	Multiplexed Source Inputs
6	D-	Multiplexed Source Inputs
7	D+	Multiplexed Source Inputs
8	$\overline{\text{OE}}$	Switch Enable
9	V _{DD}	Positive Power Supply
10	SEL	Switch Select

Maximum Ratings

(Above which useful life may be impaired. For user guidelines, not tested.)

Storage Temperature	-65°C to +150°C
Supply Voltage to Ground Potential	-0.5V to +6V
DC Input Voltage	-0.5V to +6V
DC Output Current	120mA
Power Dissipation	0.5W

Note:

Stresses greater than those listed under MAXIMUM RATINGS may cause permanent damage to the device. This is a stress rating only and functional operation of the device at these or any other conditions above those indicated in the operational sections of this specification is not implied. Exposure to absolute maximum rating conditions for extended periods may affect reliability.

DC Electrical Characteristics for USB 2.0 Switching over Operating Range

($T_A = -40^\circ\text{C}$ to $+85^\circ\text{C}$, $V_{DD} = 3.0 - 5.5\text{V}$)

Parameter	Description	Test Conditions ⁽¹⁾	Min.	Typ. ⁽²⁾	Max.	Units
V_{IH}	Input HIGH Voltage	Guaranteed HIGH level	1.4			V
V_{IL}	Input LOW Voltage	Guaranteed LOW level			0.7	
V_{IK}	Clamp Diode Voltage	$V_{DD} = \text{Max.}, I_{IK} = -18\text{mA}$		-0.7	-1.2	
I_{IH}	Input HIGH Current for SEL and \overline{OE}	$V_{DD} = \text{Max.}, V_{IH} = V_{DD}$	-100		100	nA
I_{IL}	Input LOW Current for SEL and \overline{OE}	$V_{DD} = \text{Max.}, V_{IL} = \text{GND}$	-100		100	
I_{IH}	Input HIGH Current for Y+/Y-	$V_{DD} = 3.3\text{V}, V_Y = 5.25\text{V}$			50	uA
I_{IL}	Input LOW Current for Y+/Y-	$V_{DD} = 3.3\text{V}, V_Y = 0\text{V}$			1	
$I_{Leakage}$	Leakage from Y+/Y- to Vdd when $V_{Y+/Y-} > V_{dd}$	$V_{DD} = 3.3\text{V}, V_{Y+/Y-} = 5.25\text{V}, \overline{OE} = \text{LOW}$			200	nA
R_{ON}	Switch On-Resistance ⁽³⁾	$V_{DD} = 3\text{V}, 0\text{V} \leq V_{input} \leq 0.4\text{V}, I_{ON} = -40\text{mA}$		4.0	5.0	Ω
$R_{FLAT(ON)}$	On-Resistance Flatness ⁽³⁾	$V_{DD} = 3\text{V}, 0\text{V} \leq V_{input} \leq 1.0\text{V}, I_{ON} = -40\text{mA}$		1.5		
ΔR_{ON}	On-Resistance match from center ports to any other port ⁽³⁾	$V_{DD} = 3\text{V}, 0\text{V} \leq V_{input} \leq 1.0\text{V}, I_{ON} = -40\text{mA}$		0.9	2.0	
V_{OVP}	Input Over-Voltage Protection Threshold ⁽⁴⁾	$V_{DD} = 3.0\text{V}$	3.1	3.2	3.4	V
		$V_{DD} = 3.3\text{V}$	3.4	3.5	3.7	
		$V_{DD} = 3.6\text{V}$	3.7	3.8	4.0	
I_{OZ_M}	Output leakage current on port M when D path is on	$V_{Y+/Y-} = 5.25\text{V}, V_{DD} = 3.3\text{V}$ SEL = High, $V_{M+/M-} = 0\text{V}$	-200		200	nA
I_{OZ_D}	Output leakage current on port D when M path is on	$V_{Y+/Y-} = 5.25\text{V}, V_{DD} = 3.3\text{V}$ SEL = Low, $V_{D+/D-} = 0\text{V}$	-200		200	nA
I_{OFF}	Y+/Y- Power-Off Leakage Current	$V_{input} = 0\text{V}$ to $3.3\text{V}, V_{DD} = 0\text{V}$			5	uA

Power Supply Characteristics

Parameters	Description	Test Conditions ⁽¹⁾	Min.	Typ.	Max.	Units
I_{DD}	Power Supply Current	$V_{DD} = 3.3V, \overline{OE} = GND, V_{SEL} = GND \text{ or } V_{DD}$		1	2	uA

Notes:

- For max. or min. conditions, use appropriate value specified under Electrical Characteristics for the applicable device type.
- $V_{DD} = 3.0 - 5.5V, T_A = 25^\circ C$ ambient.
- Measured by the voltage drop between Y+/Y- and the lower of M+/M- and D+/D- at indicated current through the Switch.
- When the voltage at Y+/Y- is greater than $V_{DD} + 0.2V$, over-voltage protection limits the output voltage at M+/- and D+/- to protect connected devices from damage.

Capacitance

 $(T_A = 25^\circ C, V_{DD} = 3.3V, f = 240MHz)$

Parameters ⁽³⁾	Description	Test Conditions ⁽¹⁾	Typ. ⁽²⁾	Max.	Units
C_{IN}	Input Capacitance		2.2	3.2	pF
$C_{OFF (M/D)}$	Switch Off Capacitance for M and D ports	$\overline{OE} = High$	3.0	4.0	
$C_{OFF (Y)}$	Switch Off Capacitance for Y port	$\overline{OE} = High$	5.0	6.0	
C_{ON}	Switch Capacitance, Switch ON	$V_{SEL} = 0V \text{ or } V_{DD}$	6.0	7.0	

Dynamic Electrical Characteristics Over the Operating Range

Parameters ⁽³⁾	Description	Test Conditions	Min.	Typ. ⁽²⁾	Max.	Units
X_{TALK}	Crosstalk	$R_L = 50\Omega, f = 240 MHz$		-29		dB
O_{IRR}	OFF Isolation			-28		
-3dB BW	-3dB Bandwidth	$R_L = 50\Omega$		1,000		MHz
-0.5dB BW	-0.5dB Bandwidth	$R_L = 50\Omega$		275		MHz
T_{OVP}	Over-Voltage Response Time ⁽⁴⁾	$C_L = 10 pF, V_{Y+/Y-} = 5V, V_{DD} = 3.0 \text{ to } 3.6V$ ⁽⁶⁾		40	100	ns
V_{DSW}	Dynamic Signal Output Swing ⁽⁵⁾	$C_L = 10 pF, R_L = 10k\Omega, V_{Y+/Y-} = 5V, V_{DD} = 3.0 \text{ to } 3.6V$ ⁽⁶⁾	2.7	3.0	3.6	V

Notes:

- For max. or min. conditions, use appropriate value specified under Electrical Characteristics for the applicable device type.
- Typical values are at $V_{DD} = 3.3V, T_A = 25^\circ C$ ambient.
- This parameter is determined by device characterization but is not production tested.
- Time duration for output voltage higher than V_{OVP} when input is connected to 5V.
- Output voltage observed at M+/M- and D+/D- during over-voltage condition.
- Tested using a 750 kHz square wave with $t_r = 75 ns$ and $t_f = 75 ns$.

Switching Characteristics

Parameters	Description	Test Conditions ⁽¹⁾	Min.	Typ.	Max.	Units	
t _{PD}	Propagation Delay ^(2,3)	See Test Circuit for Electrical Characteristics		0.25		ns	
t _{PZH} , t _{PZL}	Line Enable Time - SEL, \overline{OE} to D(+/-), M(+/-)		0.5		50		
t _{PHZ} , t _{PLZ}	Line Disable Time - SEL, \overline{OE} to D(+/-), M(+/-)		0.5		11.0		
t _{BBM}	Break Before Make Delay			9.0			ns
t _{SKb-b}	Output skew, bit-to-bit (opposite transition of the same output (t _{PHL} -t _{PLH}) ⁽²⁾)			8	20		ps

Notes:

1. For max. or min. conditions, use appropriate value specified under Electrical Characteristics for the applicable device type.
2. Guaranteed by design.
3. The switch contributes no propagation delay other than the RC delay of the On-Resistance of the switch and the load capacitance. The time constant for the switch alone is of the order of 0.25ns for 10pF load. Since this time constant is much smaller than the rise/fall times of typical driving signals, it adds very little propagation delay to the system. Propagation delay of the switch when used in a system is determined by the driving circuit on the driving side of the switch and its interactions with the load on the driven side.

PI3USB102E

Test Circuit for Dynamic Electrical Characteristics

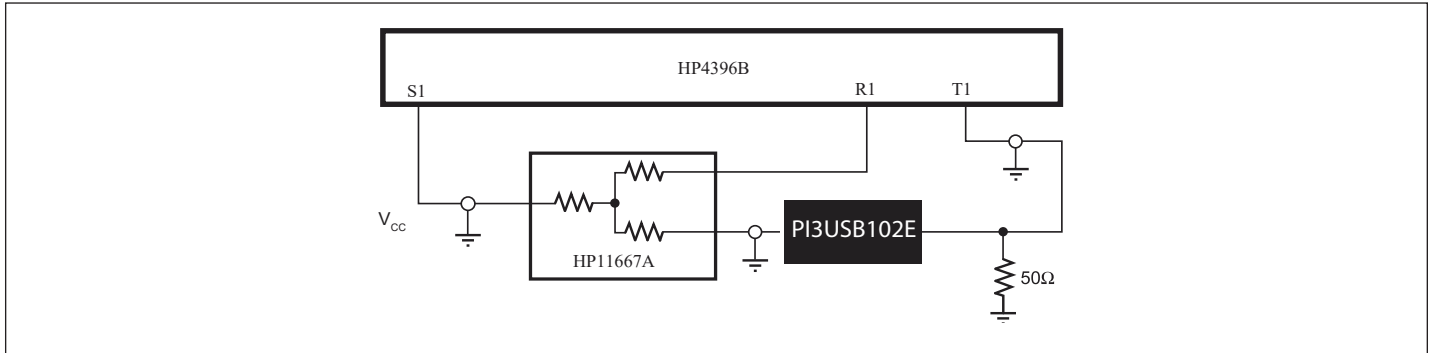

Test Circuit for Electrical Characteristics

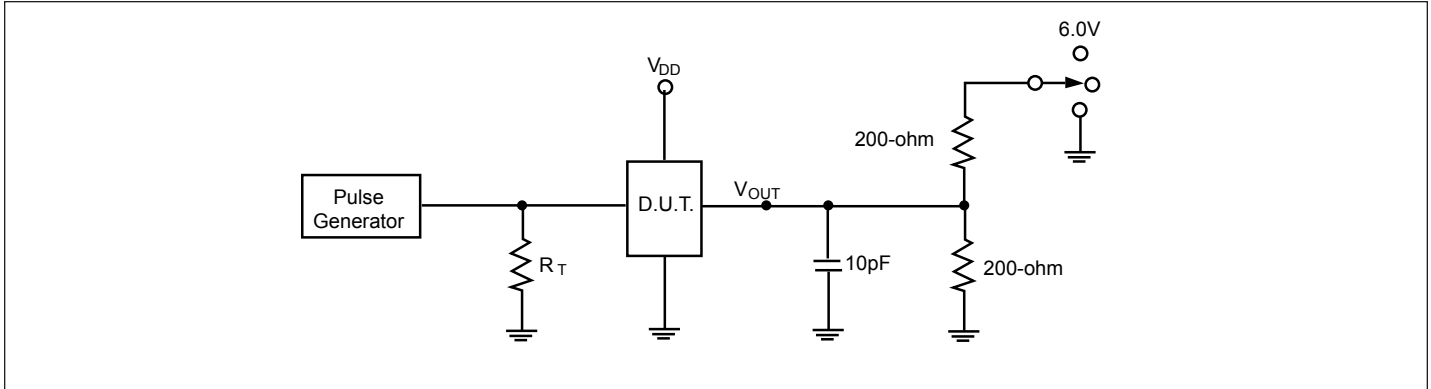

Notes:

1. C_L = Load capacitance: includes jig and probe capacitance.
2. R_T = Termination resistance: should be equal to Z_{OUT} of the Pulse Generator
3. All input impulses are supplied by generators having the following characteristics: Z_O = 50Ω, t_R ≤ 2.5ns, t_F ≤ 2.5ns.
4. The outputs are measured one at a time with on transition per measurement.

Switch Positions

Test	Switch
t _{PLZ} , t _{PZL}	6.0V
t _{PHZ} , t _{PZH}	GND
Prop Delay	Open

Application Example Diagram

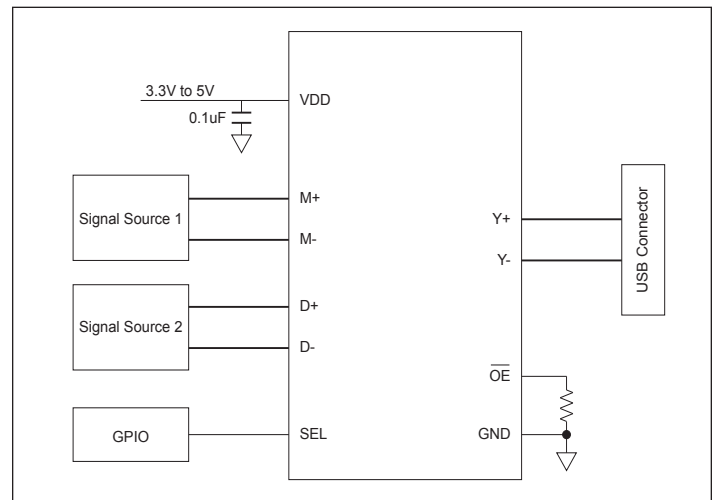

Switching Waveforms

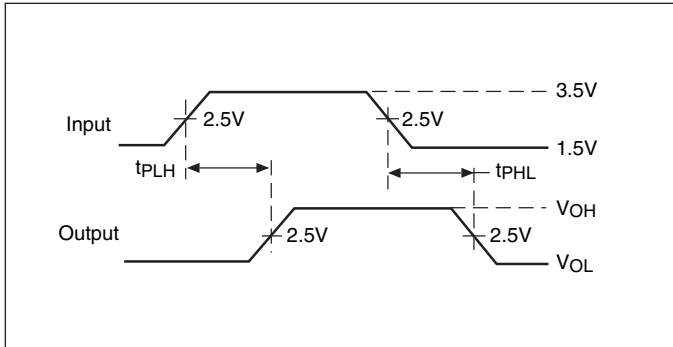

Voltage Waveforms Propagation Delay Times

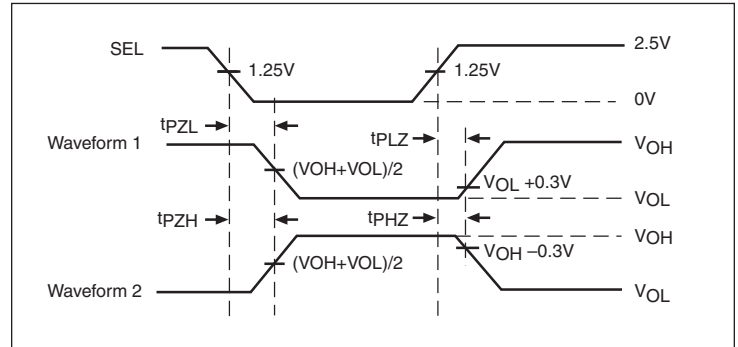

Voltage Waveforms Enable and Disable Times

Overvoltage Protection Waveforms

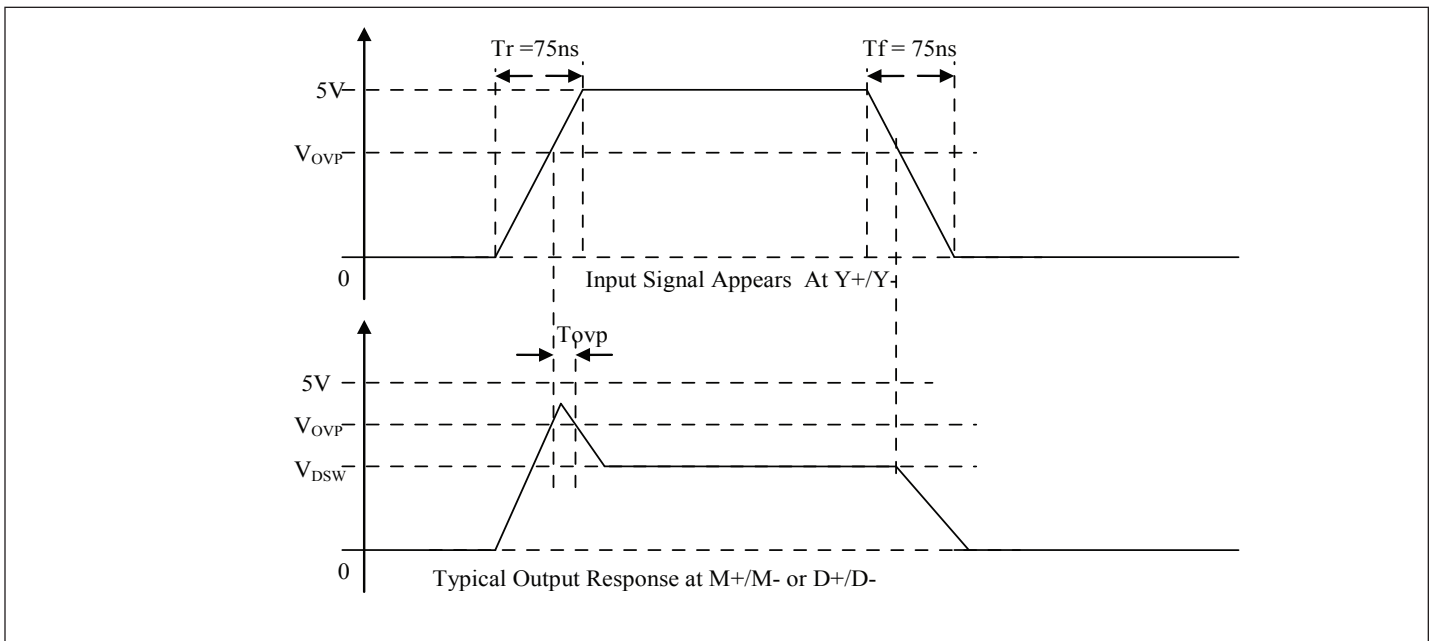

The PI3USB102E offers over voltage protection for the Y+/Y- pins to protect from shorts to VBUS (5V). When the voltage on Y+/Y- exceeds V_{OVP} , the voltage at M+/M- and D+/D- is clamped to V_{DSW} within the time T_{OVP} . For rise time of 75 ns (as per USB1.1 and USB2.0 low-speed specifications), T_{OVP} is typically 40 ns. T_{OVP} is smaller for faster risetimes. For example, T_{OVP} is typically 20 ns for rise time of 5 ns.

PI3USB102E

Part Marking

JQ
YW

JQ: PI3USB102E

Line above "J" denotes Lead-free & Pin 1 Indicator

Line above "Q" denotes Fab 3

YW: 2 letter shortened Datecode

Packaging Mechanical

10-TQFN (ZL)

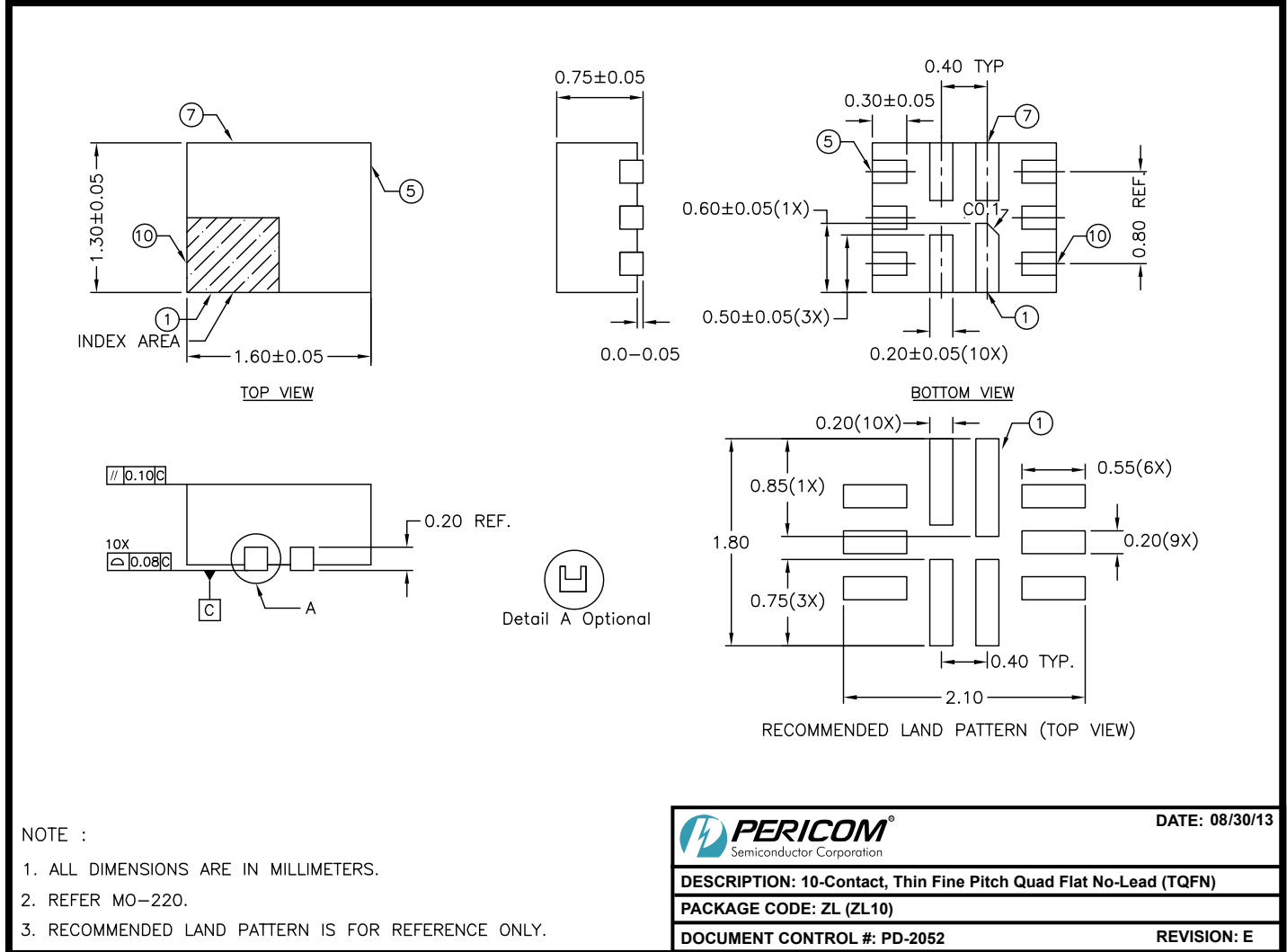

13-0175

For latest package info.

please check: <http://www.diodes.com/design/support/packaging/pericom-packaging/packaging-mechanicals-and-thermal-characteristics/>

Ordering Information

Ordering Code	Package Code	Package Description	Top Mark
PI3USB102EZLEX	ZL	10-contact, Thin Fine Pitch Quad Flat No-Lead (TQFN)	JQ

Notes:

1. No purposely added lead. Fully EU Directive 2002/95/EC (RoHS), 2011/65/EU (RoHS 2) & 2015/863/EU (RoHS 3) compliant.
2. See <https://www.diodes.com/quality/lead-free/> for more information about Diodes Incorporated's definitions of Halogen- and Antimony-free, "Green" and Lead-free.
3. Halogen- and Antimony-free "Green" products are defined as those which contain <900ppm bromine, <900ppm chlorine (<1500ppm total Br + Cl) and <1000ppm antimony compounds.
4. E = Pb-free and Green
5. X suffix = Tape/Reel

IMPORTANT NOTICE

1. DIODES INCORPORATED (Diodes) AND ITS SUBSIDIARIES MAKE NO WARRANTY OF ANY KIND, EXPRESS OR IMPLIED, WITH REGARD TO ANY INFORMATION CONTAINED IN THIS DOCUMENT, INCLUDING, BUT NOT LIMITED TO, THE IMPLIED WARRANTIES OF MERCHANTABILITY, FITNESS FOR A PARTICULAR PURPOSE OR NON-INFRINGEMENT OF THIRD PARTY INTELLECTUAL PROPERTY RIGHTS (AND THEIR EQUIVALENTS UNDER THE LAWS OF ANY JURISDICTION).
2. The Information contained herein is for informational purpose only and is provided only to illustrate the operation of Diodes' products described herein and application examples. Diodes does not assume any liability arising out of the application or use of this document or any product described herein. This document is intended for skilled and technically trained engineering customers and users who design with Diodes' products. Diodes' products may be used to facilitate safety-related applications; however, in all instances customers and users are responsible for (a) selecting the appropriate Diodes products for their applications, (b) evaluating the suitability of Diodes' products for their intended applications, (c) ensuring their applications, which incorporate Diodes' products, comply the applicable legal and regulatory requirements as well as safety and functional-safety related standards, and (d) ensuring they design with appropriate safeguards (including testing, validation, quality control techniques, redundancy, malfunction prevention, and appropriate treatment for aging degradation) to minimize the risks associated with their applications.
3. Diodes assumes no liability for any application-related information, support, assistance or feedback that may be provided by Diodes from time to time. Any customer or user of this document or products described herein will assume all risks and liabilities associated with such use, and will hold Diodes and all companies whose products are represented herein or on Diodes' websites, harmless against all damages and liabilities.
4. Products described herein may be covered by one or more United States, international or foreign patents and pending patent applications. Product names and markings noted herein may also be covered by one or more United States, international or foreign trademarks and trademark applications. Diodes does not convey any license under any of its intellectual property rights or the rights of any third parties (including third parties whose products and services may be described in this document or on Diodes' website) under this document.
5. Diodes' products are provided subject to Diodes' Standard Terms and Conditions of Sale (<https://www.diodes.com/about/company/terms-and-conditions/terms-and-conditions-of-sales/>) or other applicable terms. This document does not alter or expand the applicable warranties provided by Diodes. Diodes does not warrant or accept any liability whatsoever in respect of any products purchased through unauthorized sales channel.
6. Diodes' products and technology may not be used for or incorporated into any products or systems whose manufacture, use or sale is prohibited under any applicable laws and regulations. Should customers or users use Diodes' products in contravention of any applicable laws or regulations, or for any unintended or unauthorized application, customers and users will (a) be solely responsible for any damages, losses or penalties arising in connection therewith or as a result thereof, and (b) indemnify and hold Diodes and its representatives and agents harmless against any and all claims, damages, expenses, and attorney fees arising out of, directly or indirectly, any claim relating to any noncompliance with the applicable laws and regulations, as well as any unintended or unauthorized application.
7. While efforts have been made to ensure the information contained in this document is accurate, complete and current, it may contain technical inaccuracies, omissions and typographical errors. Diodes does not warrant that information contained in this document is error-free and Diodes is under no obligation to update or otherwise correct this information. Notwithstanding the foregoing, Diodes reserves the right to make modifications, enhancements, improvements, corrections or other changes without further notice to this document and any product described herein. This document is written in English but may be translated into multiple languages for reference. Only the English version of this document is the final and determinative format released by Diodes.
8. Any unauthorized copying, modification, distribution, transmission, display or other use of this document (or any portion hereof) is prohibited. Diodes assumes no responsibility for any losses incurred by the customers or users or any third parties arising from any such unauthorized use.
9. This Notice may be periodically updated with the most recent version available at <https://www.diodes.com/about/company/terms-and-conditions/important-notice>

DIODES is a trademark of Diodes Incorporated in the United States and other countries.

The Diodes logo is a registered trademark of Diodes Incorporated in the United States and other countries.

© 2022 Diodes Incorporated. All Rights Reserved.

www.diodes.com

Looking for pricing, stock, or lifecycle information?

Click below to explore more details on WIN SOURCE:

-  [View PI3USB102EZLE+DMX on WIN SOURCE](#)
-  [Diodes Incorporated Information](#)

Optimize Your Supply Chain with WIN SOURCE Solutions

-  Global Sourcing Solution
-  Obsolete Management
-  Cost Control Management
-  Shortage Management
-  Alternative Solution
-  Excess Inventory Management