



**THE DATASHEET OF
RT6250BHGQUF**



18V, 10A, 500kHz ACOT[®] Synchronous Step-Down Converter

General Description

The RT6250A/B is a simple, easy-to-use, 10A synchronous step-down DC-DC converter with an input supply voltage range of 4.5V to 18V. The device build-in an accurate 0.6V reference voltage and integrates low $R_{DS(ON)}$ power MOSFETs to achieve high efficiency in a UQFN-12HL 3x3 package. The RT6250A/B adopts Advanced Constant On-Time (ACOT[®]) control architecture to provide an ultrafast transient response with few external components and to operate in nearly constant switching frequency over the line, load, and output voltage range. The RT6250A/B operates in automatic PSM that maintains high efficiency during light load operation. The RT6250A/B operates in Forced PWM that helps meet tight voltage regulation accuracy requirements. The RT6250A/B senses both FETs current for a robust over-current protection. It features cycle-by-cycle current limit protection and prevent the device from the catastrophic damage in output short circuit, over current or inductor saturation. A built-in soft-start function prevents inrush current during start-up. The device also includes input under-voltage lockout, output under-voltage protection, over-voltage protection, and over-temperature protection (thermal shutdown) to provide safe and smooth operation in all operating conditions. The RT6250A/B is offered in a UQFN-12HL 3x3 (FC) package.

Applications

- Industrial and Commercial Low Power Systems
- Computer Peripherals
- LCD Monitors and TVs
- Green Electronics/Appliances
- Point of Load Regulation for High-Performance DSPs, FPGAs, and ASICs
- Networking Communication

Features

- 10A Converter With Built-in 20mΩ/10mΩ Low $R_{DS(ON)}$ Power FETs
- Input Supply Voltage Range : 4.5V to 18V
- Output Voltage Range : 0.6V to 6V
- Advanced Constant On-Time (ACOT[®]) Control
 - ▶ Ultrafast Transient Response
 - ▶ No Needs for External Compensations
 - ▶ Optimized for Low-ESR Ceramic Output Capacitors
- 0.6V ±1% High-Accuracy Feedback Reference Voltage
- Optional for Operation Modes :
 - ▶ Power Saving Mode (PSM) (RT6250A)
 - ▶ Forced PWM Mode (RT6250B)
- Fixed Switching Frequency : 500kHz
- Built-in Internally Fixed Soft-Start (Typ. 0.4ms)
- Input Under-Voltage Lockout (UVLO)
- Output Under-Voltage Protection (UVP) with Hiccup Mode
- Output Over-Voltage Protection (OVP) with Auto-Recovery Mode
- Ultrasonic Mode (USM) for RT6250A
- Available in UQFN-12HL 3x3 (FC) Package

Ordering Information

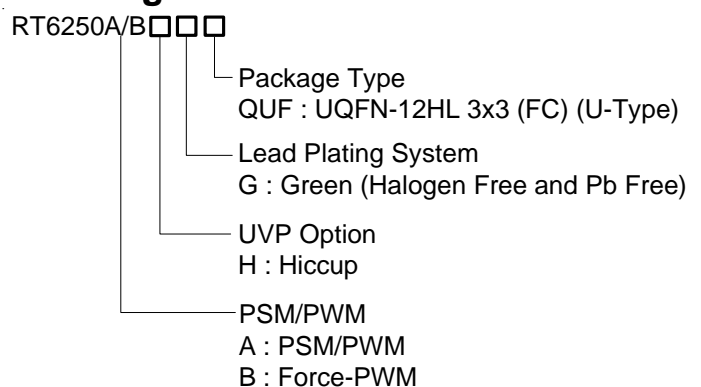

Note :

Richtek products are :

- ▶ RoHS compliant and compatible with the current requirements of IPC/JEDEC J-STD-020.
- ▶ Suitable for use in SnPb or Pb-free soldering processes.

Pin Configuration

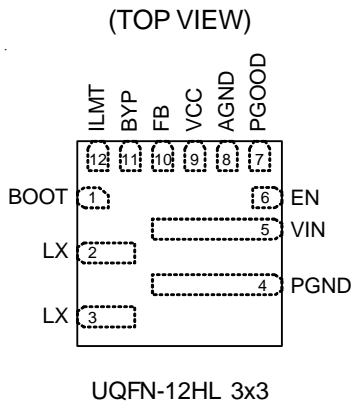

Marking Information

RT6250AHGQUF

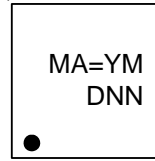

MA= : Product Code

DNN : Date Code

RT6250BHGQUF

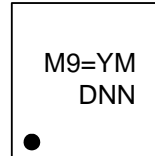

M9= : Product Code

DNN : Date Code

Simplified Application Circuit

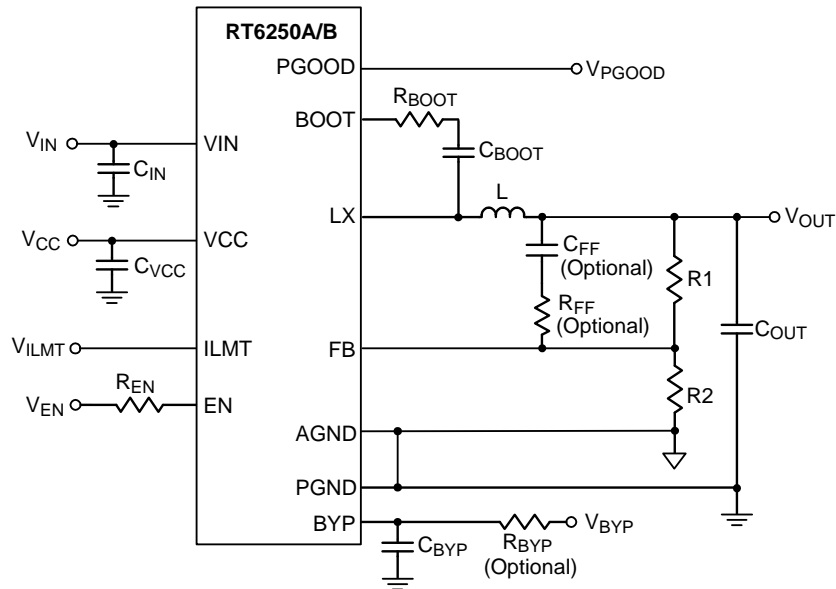

Functional Pin Description

Pin No.	Pin Name	Pin Function
1	BOOT	Boot-strap pin. Supply high-side gate driver. Decouple this pin to LX pin with 0.1 μ F ceramic cap.
2, 3	LX	Inductor pin. Connect this pin to the switching node of inductor.
4	PGND	Power ground.
5	VIN	Input pin. Decouple this pin to GND pin with at least 10 μ F ceramic cap.
6	EN	Enable control. Pull this pin high to turn on the Buck. Do not leave this pin floating. EN pin will also be used to set USM mode for RT6250A, when EN pin voltage is between 2.3V and 18V, it will enter USM mode, if EN pin voltage is between 0.8V and 1.7V, then it is normal mode.
7	PGOOD	Power good Indicator. Open drain output when the output voltage is within 90% to 120% of regulation point.
8	AGND	Analog ground. Connect AGND to a clean inner GND point with separate trace.
9	VCC	5V linear regulator output for internal control circuit. A capacitor (typical 1 μ F) should be connected to PGND. Don't connect to external Load.
10	FB	Output feedback pin. Connect this pin to the center point of the output resistor divider to program the output voltage.
11	BYP	Bypass input for the internal LDO. BYP is externally connected to the output of switching regulator. When the BYP voltage rises above the bypass switch turn-on threshold, the LDO regulator shuts down and the VCC pin is connected to the BYP pin through an internal switch. But when BYP pin is not used, it should be connected to ground.
12	ILMT	Current limit setting pin. The current limit is set to 8A, 10A or 12A when this pin is pull low, floating or pull high respectively.

Functional Block Diagram

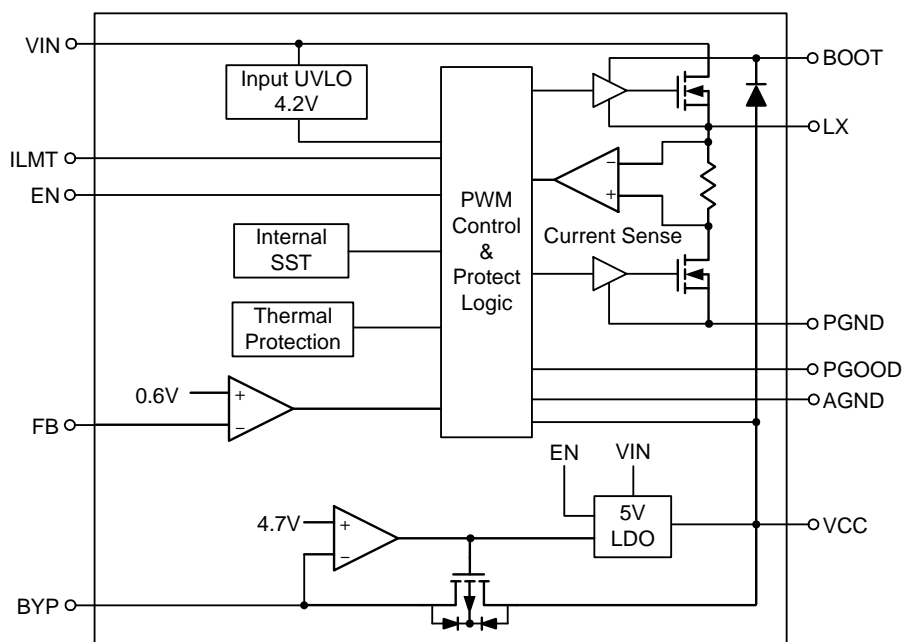

Operation

The RT6250A/B is a high-efficiency, synchronous step-down DC-DC converter that can deliver up to 10A output current from a 4.5V to 18V input supply. The RT6250A/B adopts ACOT[®] control mode, which can reduce the output capacitance and provide ultrafast transient responses, and allow minimal component sizes without any additional external compensation network.

Input Under-Voltage Lockout

In addition to the EN pin, the RT6250A/B also provides enable control through the VIN pin. It features an under-voltage lockout (UVLO) function that monitors the internal linear regulator (VCC). If V_{EN} rises above V_{ENH} first, switching will still be inhibited until the VIN voltage rises above V_{UVLO} . It is to ensure that the internal regulator is ready so that operation with not-fully-enhanced internal MOSFET switches can be prevented. After the device is powered up, if the input voltage VIN goes below the UVLO falling threshold voltage ($V_{UVLO} - \Delta V_{UVLO}$), this switching will be inhibited; if VIN rises above the UVLO rising threshold (V_{UVLO}), the device will resume switching.

Soft-Start

The soft-start function is used to prevent large inrush currents while the converter is being powered up. The RT6250A/B provides an internal soft-start feature for inrush control. During the start-up sequence, the internal capacitor is charged by an internal current source I_{SS} to generate a soft-start ramp voltage as a reference voltage to the PWM comparator. The device will initiate switching and the output voltage will smoothly ramp up to its targeted regulation voltage only after this ramp voltage is greater than the feedback voltage V_{FB} to ensure the converters have a smooth start-up. The typical soft-start time is 0.4ms.

Over-Current Limit

The RT6250A/B current limit is (8A, 10A, 12A) it is a cycle-by-cycle "valley" type, measuring the inductor current through the synchronous rectifier during the off-time while the inductor current ramps down. If output voltage drops below the output under-voltage protection level, the RT6250A/B will stop switching to avoid excessive heat.

Output Over-Voltage Protection (OVP) and Under-Voltage Protection (UVP)

The RT6250A/B includes output under-voltage protection (UVP) against over-load or short-circuited condition by constantly monitoring the feedback voltage V_{FB} . If V_{FB} drops below the under-voltage protection trip threshold (typically 60% of the internal reference voltage), the UV comparator will go high to turn off both the internal high-side and low-side MOSFET switches.

Power Good

The PGOOD pin is an open-drain output and is connected to an external pull-up resistor. It is controlled by a comparator, which the feedback signal V_{FB} is fed to. If V_{FB} is above 90% of the internal reference voltage, the PGOOD pin will be in high impedance and V_{PGOOD} will be held high. Otherwise, the PGOOD output will be pulled low.

Over-Temperature Protection (Thermal Shutdown)

The RT6250A/B includes an over-temperature protection (OTP) circuitry to prevent overheating due to excessive power dissipation. The OTP will shut down switching operation when junction temperature exceeds a thermal shutdown threshold T_{SD} . Once the junction temperature cools down by a thermal shutdown hysteresis (ΔT_{SD}), the IC will resume normal operation with a complete soft-start.

Absolute Maximum Ratings (Note 1)

- Supply Voltage, V_{IN} ----- -0.3V to 20V
- Enable Pin Voltage, EN ----- -0.3V to 20V
- FB Pin Voltage, FB ----- -0.3V to 4.5V
- Switch Voltage, LX ----- -0.3V to ($V_{IN} + 0.3V$)
- <30ns ----- -5V to 21V
- Boot Voltage, BOOT ----- ($V_{LX} - 0.3V$) to ($V_{LX} + 6V$)
- Other I/O Pin Voltages ----- -0.3V to 6V
- Power Dissipation, P_D @ $T_A = 25^\circ C$
- UQFN-12HL 3x3 (FC) ----- 2.9W
- Package Thermal Resistance (Note 2)
- UQFN-12HL 3x3 (FC), θ_{JA} ----- 34.3°C/W
- UQFN-12HL 3x3 (FC), ψ_{JC} ----- 0.21°C/W
- Lead Temperature (Soldering, 10 sec.) ----- 260°C
- Junction Temperature ----- 150°C
- Junction Temperature Range ----- -40°C to 125°C
- Storage Temperature Range ----- -65°C to 150°C
- ESD Susceptibility (Note 3)
- HBM (Human Body Model) ----- 2kV

Recommended Operating Conditions (Note 4)

- Supply Input Voltage V_{IN} ----- 4.5V to 18V
- Ambient Temperature Range ----- -40°C to 85°C

Electrical Characteristics

($V_{IN} = 12V$, $T_A = 25^\circ C$, unless otherwise specified)

Parameter	Symbol	Test Conditions	Min	Typ	Max	Unit
Input Voltage Range	V_{IN}		4.5	--	18	V
Supply Current						
Supply Current (Shutdown)	I_{SHDN}	$V_{EN} = 0$	--	5	10	μA
Supply Current (Quiescent)	I_Q	$I_{OUT} = 0$, $V_{FB} = V_{REF} \times 105\%$	--	130	--	μA
Logic Threshold						
EN Input Low Voltage	V_{ENL}		0.4	0.54	0.68	V
EN Input High Voltage	V_{ENH}		0.45	0.625	0.8	V
Ultra-Sonic Mode	V_{EN}		2.3	--	--	V
Normal Mode	V_{EN}		--	--	1.7	V
Output Voltage						
VCC Regulator Voltage	V_{CC}		--	5	--	V
Feedback Voltage						
Feedback Reference Voltage	V_{REF}		0.594	0.6	0.606	V
Feedback Current	I_{FB}	$V_{FB} = 4V$	-50	--	50	nA

Parameter	Symbol	Test Conditions	Min	Typ	Max	Unit
On Resistance						
High-Side Switch On Resistance	R _{DS(ON)_H}		--	20	--	mΩ
Low-Side Switch On Resistance	R _{DS(ON)_L}		--	10	--	mΩ
Discharge FET Ron	R _{DISCHG}		--	50	--	Ω
Current Limit						
Bottom FET Current Limit	I _{LIM}	I _{LIMT} = "0"	8	--	--	A
		I _{LIMT} = Floating	10	--	--	
		I _{LIMT} = "1"	12	--	--	
ILMT Rising Threshold	V _{ILMTH}		V _{CC} - 0.8	--	V _{CC}	V
ILMT Falling Threshold	V _{ILMTL}		--	--	0.8	V
Oscillator Frequency						
Oscillator Frequency	f _{OSC}		--	0.5	--	MHz
On-Time Timer Control						
Minimum On-Time	t _{ON_MIN}	V _{IN} = V _{IN(MAX)}	--	50	--	ns
Minimum Off-Time	t _{OFF_MIN}		--	400	--	ns
Ultrasonic Mode						
Operation Period	t _{USM}		20	30	40	μs
Soft-Start						
Power Good Enable Delay Time		From EN high to PGOOD high	1.3	1.65	2	ms
Soft-Start Time	t _{SS}	From 10% to 90% V _{OUT}	--	0.4	--	ms
UVLO						
Input UVLO Threshold	V _{UVLO}	Wake up	--	--	4.4	V
UVLO Hysteresis	V _{UVLO_HYS}		--	0.3	--	V
Output Over-Voltage Protection						
Output Over-Voltage Threshold		V _{OUT} rising	115	120	125	%
Output Over-Voltage Hysteresis			--	3	--	%
Output Over-Voltage Delay Time			--	20	--	μs
Output Under-Voltage Protection						
Output Under-Voltage Threshold		V _{FB} falling	--	60	--	%
Output Under-Voltage Delay Time		FB Forced below UV threshold	--	20	--	μs
UV Blank Time		From EN high	--	1.65	--	ms
Power Good						
Power Good Threshold		V _{OUT} rising (Good)	88	90	92	%
Power Good Hysteresis			--	15	--	%
Power Good Delay Time			--	10	--	μs

Parameter	Symbol	Test Conditions	Min	Typ	Max	Unit
Bypass Switch						
Bypass Switch RON	R _{BYP}		--	3	--	Ω
Bypass Switch Turn-On Voltage	V _{BYP_ON}		--	4.7	--	V
Bypass Switch Switchover Hysteresis			--	0.2	--	V
Thermal Shutdown						
Thermal Shutdown Threshold	T _{SD}		--	150	--	°C
Thermal Shutdown Hysteresis	ΔT _{SD}		--	15	--	°C

Note 1. Stresses beyond those listed “Absolute Maximum Ratings” may cause permanent damage to the device. These are stress ratings only, and functional operation of the device at these or any other conditions beyond those indicated in the operational sections of the specifications is not implied. Exposure to absolute maximum rating conditions may affect device reliability.

Note 2. θ_{JA} is measured in the natural convection at T_A = 25°C on a four-layer Richtek Evaluation Board. ψ_{JC} is measured at the top of the package.

Note 3. Devices are ESD sensitive. Handling precaution is recommended.

Note 4. The device is not guaranteed to function outside its operating conditions.

Typical Application Circuit

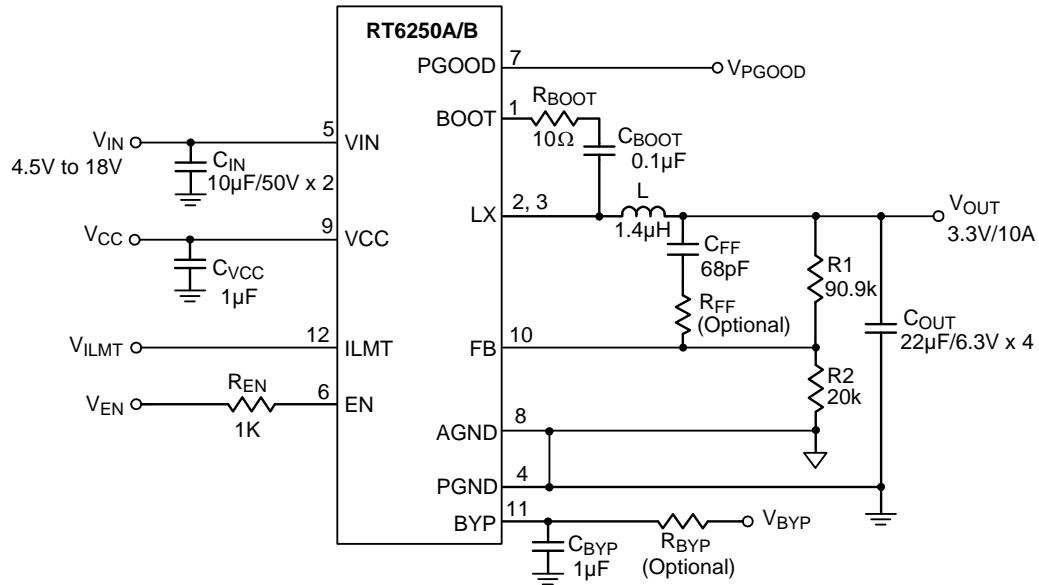

Table 1. Suggested Component Values

V _{OUT} (V)	R1 (kΩ)	R2 (kΩ)	L (μ)	C _{OUT} (μF)	C _{FF} (pF)
1	13.3	20	0.68	22x4/0805/6.3V	82
1.2	20	20	0.68	22x4/0805/6.3V	82
1.8	40.2	20	1	22x4/0805/6.3V	82
2	46.6	20	1	22x4/0805/6.3V	82
3.3	90.9	20	1.4	22x4/0805/6.3V	68
5	147	20	2.2	22x4/0805/6.3V	68

Table 2. USM Suggested Component Values

V _{OUT} (V)	R1 (kΩ)	R2 (kΩ)	L (μH)	C _{OUT} (μF)	C _{FF} (pF)
1	13.3	20	1	22x4/0805/6.3V	100
1.2	20	20	1	22x4/0805/6.3V	100
1.8	40.2	20	1	22x4/0805/6.3V	100
2	46.6	20	2.2	22x4/0805/6.3V	100
3.3	90.9	20	2.2	22x4/0805/6.3V	100
5	147	20	2.2	22x4/0805/6.3V	100

Note : All the input and output capacitors are the suggested values, referring to the effective capacitances, subject to any de-rating effect, like a DC bias.

Typical Operating Characteristics

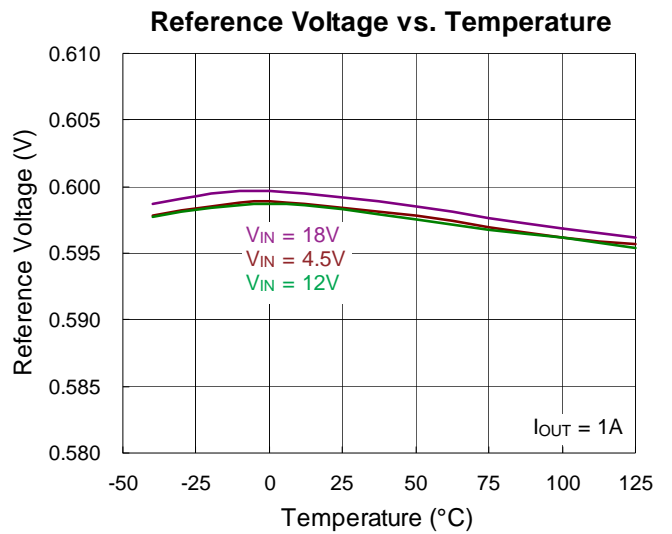
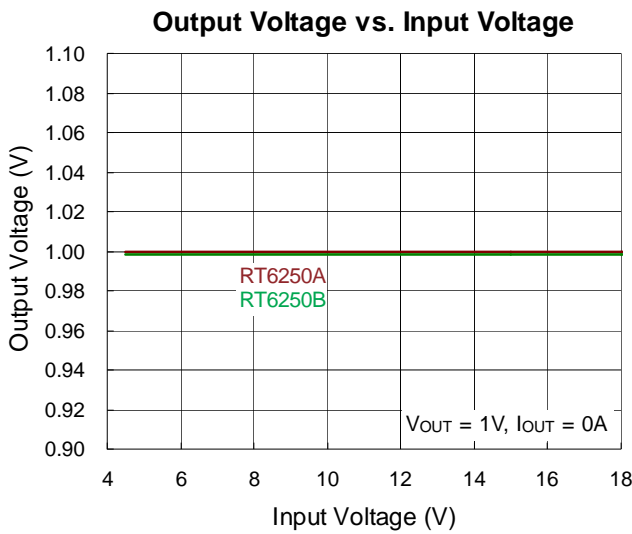
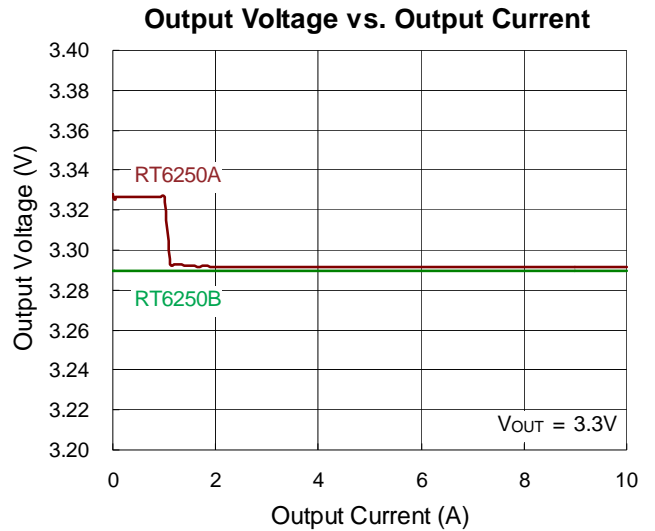
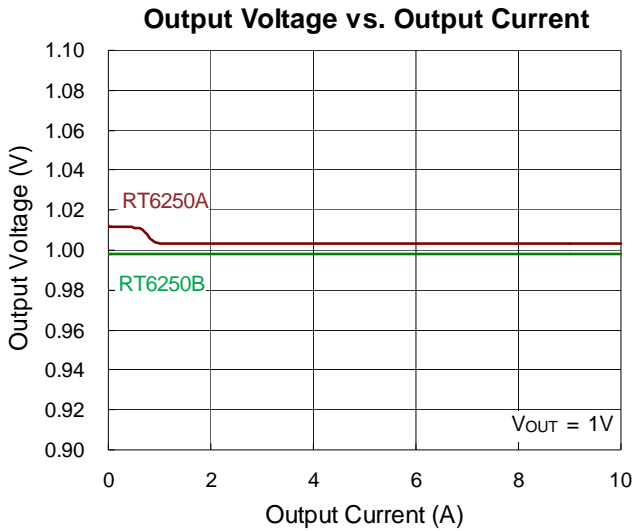
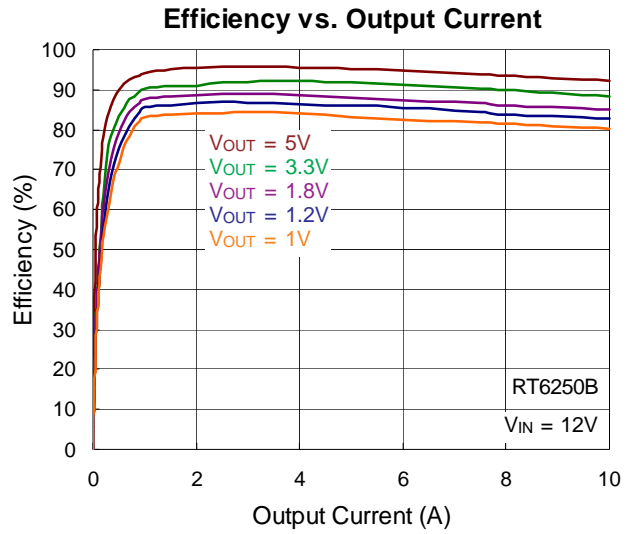
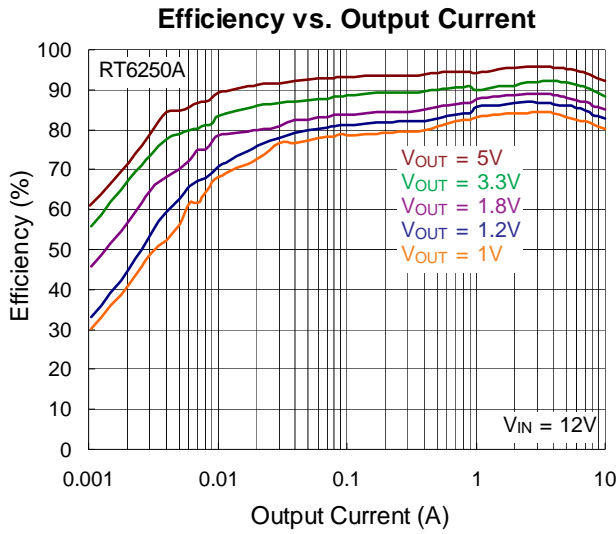

Load Transient

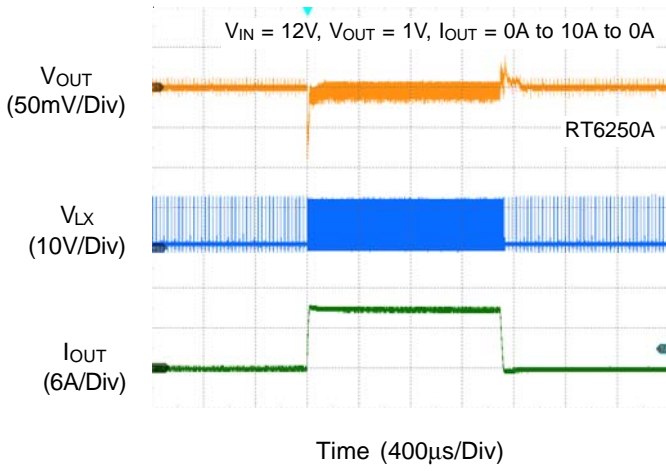

Load Transient

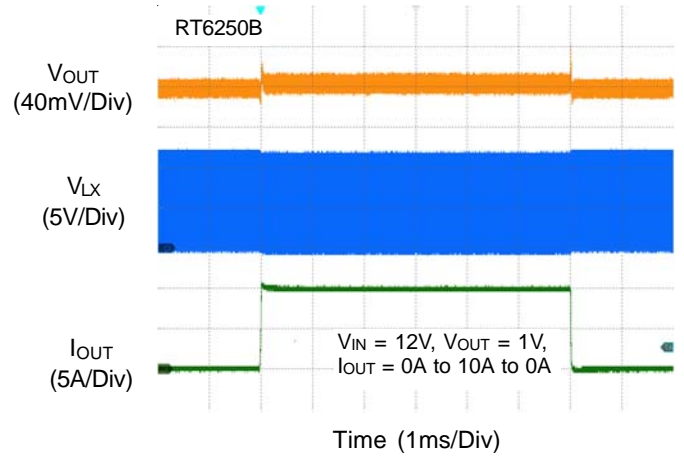

Load Transient

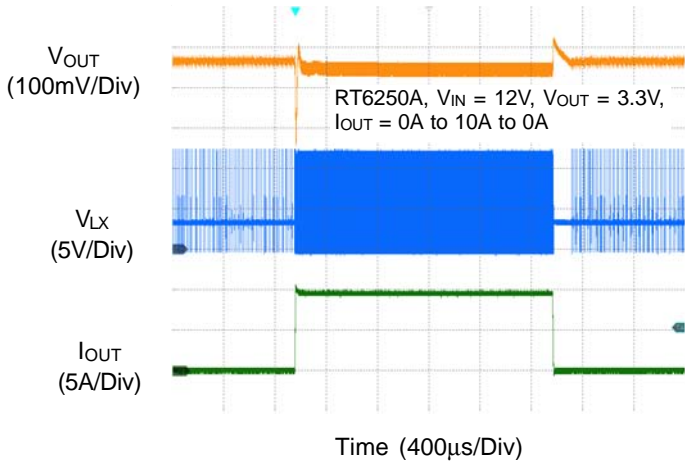

Load Transient

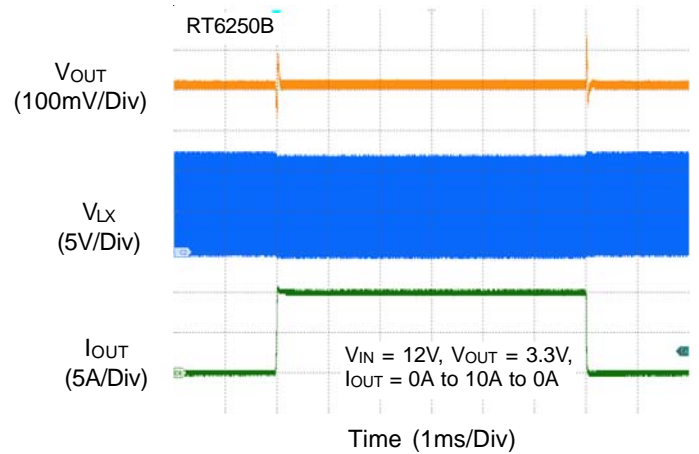

Application Information

The RT6250A/B are high-performance 10A step-down regulators with internal power switches and synchronous rectifiers. They feature an Advanced Constant On-Time (ACOT[®]) control architecture that provides stable operation for ceramic output capacitors without complicated external compensation, among other benefits. The input voltage range is from 4.5V to 18V. The output voltage is adjustable from 0.6V to 6V.

The proprietary ACOT[®] control scheme improves conventional constant on-time architectures, achieving nearly constant switching frequency over line, load, and output voltage ranges. Since there is no internal clock, response to transients is nearly instantaneous and inductor current can ramp quickly to maintain output regulation without large bulk output capacitance.

ACOT[®] Control Architecture

The conventional CFCOT (constant frequency constant on-time) control which making the on-time proportional to VOUT and inversely proportional to VIN is not sufficient to achieve good constant-frequency behavior. Because voltage drops across the MOSFET switches and inductor cause sensing mismatch as sensing input and output voltage from LX pin. When the load change, the voltage drops across the MOSFET switches and inductor cause a switching frequency variation with load current. One way to reduce these effects is to measure the actual switching frequency and compare it to the desired range. This has the added benefit eliminating the need to sense the actual output voltage, potentially saving one pin connection. ACOT[®] uses this method, measuring the actual switching frequency and modifying the on-time with a feedback loop to keep the average switching frequency in the desired range.

In order to achieve good stability with low-ESR ceramic capacitors, ACOT[®] uses a virtual inductor current ramp generated inside the IC. This internal ramp signal replaces the ESR ramp normally provided by the output capacitor's ESR. The ramp signal and other internal compensations are optimized for low-ESR ceramic output capacitors.

ACOT[®] One-Shot Operation

The RT6250A/B control algorithm is simple to understand. The feedback voltage, with the virtual inductor current ramp added, is compared to the reference voltage. When the combined signal is less than the reference, the on-time one-shot is triggered as long as the minimum off-time one-shot is clear and the measured inductor current (through the synchronous rectifier) is below the current limit. The on-time one-shot turns on the high-side switch and the inductor current ramps up linearly. After the on-time, the high-side switch is turned off and the synchronous rectifier is turned on and the inductor current ramps down linearly. At the same time, the minimum off-time one-shot is triggered to prevent another immediate on-time during the noisy switching time and allow the feedback voltage and current sense signals to settle. The minimum off-time is kept short (400ns typical) so that rapidly-repeated on-times can raise the inductor current quickly when needed.

Diode Emulation Mode (DEM)

In diode emulation mode, the RT6250A/B automatically reduces switching frequency at light load conditions to maintain high efficiency. This reduction of frequency is achieved smoothly. As the output current decreases from heavy load condition, the inductor current is also reduced, and eventually comes to the point that its current valley touches zero, which is the boundary between continuous conduction and discontinuous conduction modes. To emulate the behavior of diodes, the low-side MOSFET allows only partial negative current to flow when the inductor free wheeling current becomes negative. As the load current is further decreased, it takes longer and longer time to discharge the output capacitor to the level that requires the next "ON" cycle. In reverse, when the output current increases from light load to heavy load, the switching frequency increases to the preset value as the inductor current reaches the continuous conduction. The transition load point to the light load operation is shown in Figure 1. and can be calculated as follows :

$$I_{LOAD} = \frac{(V_{IN} - V_{OUT})}{2L} \times t_{ON}$$

where t_{ON} is the on-time.

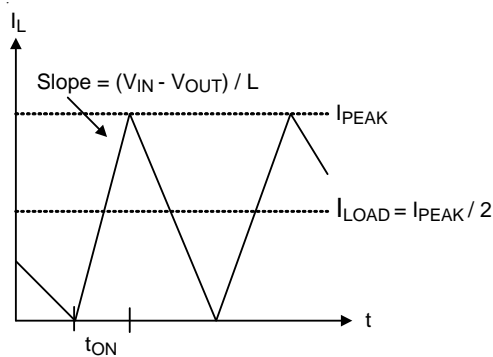

Figure 1. Boundary Condition of CCM/DEM

The switching waveforms may appear noisy and asynchronous when light load causes diode emulation operation. This is normal and results in high efficiency. Trade offs in DEM noise vs. light load efficiency is made by varying the inductor value. Generally, low inductor values produce a broader efficiency vs. load curve, while higher values result in higher full load efficiency (assuming that the coil resistance remains fixed) and less output voltage ripple. Penalties for using higher inductor values include larger physical size and degraded load transient response (especially at low input voltage levels).

At boundary condition of discontinuous switching and continuous, the on-time is immediately increased to add “hysteresis” to discourage the IC from discontinuous switching back to continuous switching unless the load increases substantially. The IC returns to continuous switching as soon as an on-time is generated before the inductor current reaches zero. The on-time is reduced back to the length needed for designed switching frequency and encouraging the circuit to remain in continuous conduction, preventing repetitive mode transitions between continuous switching and discontinuous switching.

Ultrasonic Mode (USM)

The RT6250A activates a unique type of diode emulation mode with a minimum switching period of 30µs (typical), called ultrasonic mode. This mode eliminates audio-frequency modulation that would otherwise be present

when a lightly loaded controller automatically skips pulses. In ultrasonic mode, the low-side switch gate driver signal is “OR”ed with an internal oscillator (>33kHz).

Once the internal oscillator is triggered, the controller will turn on UGATE and give it shorter on-time. When the on-time expired, LGATE turns on until the inductor current goes to zero crossing threshold and keep both high-side and low-side MOSFET off to wait for the next trigger. Because shorter on-time causes a smaller pulse of the inductor current, the controller can keep output voltage and switching frequency simultaneously. The on-time decreasing has a limitation and the output voltage will be lifted up under the slight load condition. The controller will turn on LGATE first to pull down the output voltage. When the output voltage is pulled down to the balance point of the output load current, the controller will proceed the short on-time sequence as the above description.

Ultrasonic mode is selected by the EN voltage level. When EN is above 2.3V, it enters ultrasonic mode. If EN is in the range of 0.8V to 1.7V, it enters normal mode. If use the ultrasonic mode must use the RT provide BOM.

On-Time Reduction Function for DEM

In normal diode emulation mode, the output voltage ripple of converter is proportional to on-time and inversely proportional to load current. In order to have smaller voltage ripple in light load application, the RT6250A/B provide a smart reduction on-time function, which will follow decreased load current to decrease on-time naturally, therefore the output voltage ripple can be reduced effectively.

Linear Regulators (VCC)

The RT6250A/B also includes a 5V linear regulator (VCC). The VCC regulator steps down input voltage to supply both internal circuitry and gate drivers. Do not connect the VCC pin to external loads.

Bypass Function for VCC

When PGOOD is pulled high and BYP pin of the RT6250A/B voltage is above 4.7V, an internal 3Ω P-MOSFET switch connects VCC to the BYP pin while the VCC linear regulator is simultaneously turned off. Because

the VCC is power source for internal logic device and gate driver. If bypass function was enabled, it's recommended to put a RC filter to BYP pin to enhance power quality for IC internal power. But when BYP pin is not used, it should be connected to ground.

Current Limit

The RT6250A/B current limit is adjustable (8A,10A,12A) by ILMT pin and it is a cycle-by-cycle “valley” type, measuring the inductor current through the synchronous rectifier during the off-time while the inductor current ramps down. The current is determined by measuring the voltage between source and drain of the synchronous rectifier, adding temperature compensation for greater accuracy. If the current exceeds the current limit, the on-time one-shot is inhibited until the inductor current ramps down below the current limit. Thus, only when the inductor current is well below the current limit, another on-time is permitted. If the output current exceeds the available inductor current (controlled by the current limit mechanism), the output voltage will drop. If it drops below the output under-voltage protection level (see next section) the IC will stop switching to avoid excessive heat.

Output Over-Voltage Protection and Under-Voltage Protection

The RT6250A/B include output over-voltage protection (OVP). If the output voltage rises above the regulation level, the high-side switch naturally remains off and the synchronous rectifier will turn on until the inductor current reaches the zero or next on-time one-shot is triggered. If the output voltage exceeds the OVP threshold for longer than 20μs (typical), the IC's OVP is triggered. The RT6250A/B also include output under-voltage protection (UVP). If the output voltage drops below the UVP trip threshold for longer than 20μs (typical) the IC's UVP is triggered. The RT6250A/B use auto-recovery mode in OVP and Hiccup Mode in UVP. When the UVP function is triggered remains for a period, the RT6250A/B will retry automatically. When the UVP condition is removed, the converter will resume operation. the UVP is disabled during soft-start period. If the OVP function is triggered, the IC will stop switching. When the OVP condition is removed, the converter will resume operation.

Input Under-Voltage Lockout

In addition to the enable function, the RT6250A/B provide an Under-Voltage Lockout (UVLO) function that monitors the input voltage. To prevent operation without fully-enhanced internal MOSFET switches, this function inhibits switching when input voltage drops below the UVLO-falling threshold. The IC resumes switching when input voltage exceeds the UVLO-rising threshold.

Enable and Disable

The RT6250A/B's EN is used to control converter, the enable voltage (EN) has a logic-low level of 0.4V. When V_{EN} is below this level the IC enters shutdown mode. When V_{EN} exceeds its logic-high level of 0.8V the converter is fully operational.

Soft-Start

The RT6250A/B provide an internal soft-start function to prevent large inrush current and output voltage overshoot when the converter starts up. The soft-start (SS) automatically begins once the chip is enabled. During soft-start, it clamps the ramping of internal reference voltage which is compared with FB signal. The typical soft-start duration is 0.4ms. A unique PWM duty limit control that prevents output over-voltage during soft-start period is designed specifically for FB floating.

Power Good Output (PGOOD)

The power good output is an open drain output that requires a pull-up resistor. When the output voltage is 15% (typical) below its set voltage, PGOOD will be pulled low. It is held low until the output voltage returns to 90% of its set voltage once more. During soft-start, PGOOD is actively held low and only allowed to be pulled high after soft-start is over and the output reaches 90% of its set voltage. There is a 10μs delay built into PGOOD circuitry to prevent false transition.

External Bootstrap Capacitor (C_{BOOT})

Connect a 0.1μF low ESR ceramic capacitor between BOOT pin and LX pin. This bootstrap capacitor provides the gate driver supply voltage for the high-side N-channel MOSFET switch.

The internal power MOSFET switch gate driver is optimized to turn the switch on fast enough for low power loss and good efficiency, but also slow enough to reduce EMI. Switch turn-on is when most EMI occurs since V_{LX} rises rapidly. In some cases, it is desirable to reduce EMI further, by the expense of some additional power dissipation. The switch turn-on can be slowed by placing a small ($10\Omega \leq R_{BOOT} \leq 30\Omega$) resistance between BOOT and the external bootstrap capacitor. This will slow the high-side switch turn-on and V_{LX} 's rise. In order to improve EMI performance and enhancement of the internal MOSFET switch.

Output Voltage Setting

Set the desired output voltage using a resistive divider from the output to ground with the midpoint connected to FB. The output voltage is set according to the following equation :

$$V_{OUT,VALLEY} = \left(1 + \frac{R1}{R2}\right) \times 0.6V$$

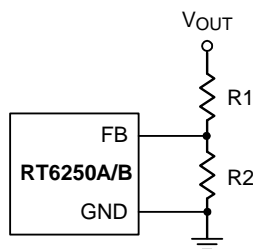

Figure 2. Output Voltage Setting

Place the FB resistors within 5mm of the FB pin. Choose R2 between 10kΩ and 100kΩ to minimize power consumption without excessive noise pick-up and calculate R1 as follows :

$$R1 = \frac{R2 \times (V_{OUT} - 0.6V)}{0.6V}$$

For output voltage accuracy, use divider resistors with 1% or better tolerance.

Inductor Selection

Selecting an inductor involves specifying its inductance and also its required peak current. The exact inductor value is generally flexible and is ultimately chosen to obtain the best mix of cost, physical size, and circuit efficiency. Lower inductor values benefit from reduced size and cost and they can improve the circuit's transient response, but they increase the inductor ripple current and output voltage ripple and reduce the efficiency due to the resulting higher peak currents. Conversely, higher inductor values increase efficiency, but the inductor will either be physically larger or have higher resistance since more turns of wire are required and transient response will be slower since more time is required to change current (up or down) in the inductor. A good compromise between size, efficiency, and transient response is to use a ripple current (ΔI_L) about 20-50% of the desired full output load current. Calculate the approximate inductor value by selecting the input and output voltages, the switching frequency (f_{SW}), the maximum output current ($I_{OUT(MAX)}$) and estimating a ΔI_L as some percentage of that current.

$$L = \frac{V_{OUT} \times (V_{IN} - V_{OUT})}{V_{IN} \times f_{SW} \times \Delta I_L}$$

Once an inductor value is chosen, the ripple current (ΔI_L) is calculated to determine the required peak inductor current.

$$\Delta I_L = \frac{V_{OUT} \times (V_{IN} - V_{OUT})}{V_{IN} \times f_{SW} \times L} \text{ and}$$

$$I_{L(PEAK)} = I_{OUT(MAX)} + \frac{\Delta I_L}{2}$$

To guarantee the required output current, the inductor needs a saturation current rating and a thermal rating that exceeds $I_{L(PEAK)}$. These are minimum requirements. To maintain control of inductor current in overload and short-circuit conditions, some applications may desire current ratings up to the current limit value. However, the IC's output under-voltage shutdown feature make this unnecessary for most applications.

For best efficiency, choose an inductor with a low DC resistance that meets the cost and size requirements. For low inductor core losses some type of ferrite core is usually best and a shielded core type, although possibly larger or more expensive, will probably give fewer EMI and other noise problems.

Input Capacitor Selection

High quality ceramic input decoupling capacitor, such as X5R or X7R, with values greater than 20μF are recommended for the input capacitor. The X5R and X7R ceramic capacitors are usually selected for power regulator capacitors because the dielectric material has less capacitance variation and more temperature stability. Voltage rating and current rating are the key parameters when selecting an input capacitor. Generally, selecting an input capacitor with voltage rating 1.5 times greater than the maximum input voltage is a conservatively safe design. The input capacitor is used to supply the input RMS current, which can be calculated using the following equation :

$$I_{RMS} = \sqrt{\frac{V_{OUT}}{V_{IN}} \times \left[\left(1 - \frac{V_{OUT}}{V_{IN}}\right) \times I_{OUT}^2 + \frac{\Delta I_L^2}{12} \right]}$$

The next step is to select a proper capacitor for RMS current rating. One good design uses more than one capacitor with low Equivalent Series Resistance (ESR) in parallel to form a capacitor bank. The input capacitance value determines the input ripple voltage of the regulator. The input voltage ripple can be approximately calculated using the following equation :

$$\Delta V_{IN} = \frac{I_{OUT} \times V_{IN}}{C_{IN} \times f_{SW} \times V_{OUT}} \times \left(1 - \frac{V_{OUT}}{V_{IN}}\right)$$

The typical operating circuit is recommended to use two 10μF low ESR ceramic capacitors on the input.

Output Capacitor Selection

The IC is optimized for ceramic output capacitors and best performance will be obtained by using them. The total output capacitance value is usually determined by the desired output voltage ripple level and transient response requirements for sag (undershoot on positive load steps) and soar (overshoot on negative load steps).

Output ripple at the switching frequency is caused by the inductor current ripple and its effect on the output capacitor's ESR and stored charge. These two ripple components are called ESR ripple and capacitive ripple. Since ceramic capacitors have extremely low ESR and relatively little capacitance, both components are similar in amplitude and both should be considered if ripple is critical.

$$V_{RIPPLE} = V_{RIPPLE(ESR)} + V_{RIPPLE(C)}$$

$$V_{RIPPLE(ESR)} = \Delta I_L \times R_{ESR}$$

$$V_{RIPPLE(C)} = \frac{\Delta I_L}{8 \times C_{OUT} \times f_{SW}}$$

In addition to voltage ripple at the switching frequency, the output capacitor and its ESR also affect the voltage sag (undershoot) and soar (overshoot) when the load steps up and down abruptly. The ACOT[®] transient response is very quick and output transients are usually small. However, the combination of small ceramic output capacitors (with little capacitance), low output voltages (with little stored charge in the output capacitors), and low duty cycle applications (which require high inductance to get reasonable ripple currents with high input voltages) increases the size of voltage variations in response to very quick load changes. Typically, load changes occur slowly with respect to the IC's switching frequency. However, some modern digital loads can exhibit nearly instantaneous load changes and the following section shows how to calculate the worst-case voltage swings in response to very fast load steps.

The amplitude of the ESR step up or down is a function of the load step and the ESR of the output capacitor :

$$V_{ESR_STEP} = \Delta I_{OUT} \times R_{ESR}$$

The amplitude of the capacitive sag is a function of the load step, the output capacitor value, the inductor value, the input-to-output voltage differential, and the maximum duty cycle. The maximum duty cycle during a fast transient is a function of the on-time and the minimum off-time since the ACOT[®] control scheme will ramp the current using on-times spaced apart with minimum off-times, which is as fast as allowed. Calculate the approximate on-time (neglecting parasitics) and maximum duty cycle for a given input and output voltage as :

$$t_{ON} = \frac{V_{OUT}}{V_{IN} \times f_{SW}} \text{ and } D_{MAX} = \frac{t_{ON}}{t_{ON} + t_{OFF_MIN}}$$

The actual on-time will be slightly longer as the IC compensates for voltage drops in the circuit, but we can neglect both of these since the on-time increases compensations for the voltage losses. Calculate the output voltage SAG as :

$$V_{SAG} = \frac{L \times (\Delta I_{OUT})^2}{2 \times C_{OUT} \times (V_{IN(MIN)} \times D_{MAX} - V_{OUT})}$$

The amplitude of the capacitive SOAR is a function of the load step, the output capacitor value, the inductor value and the output voltage :

$$V_{SOAR} = \frac{L \times (\Delta I_{OUT})^2}{2 \times C_{OUT} \times V_{OUT}}$$

Most applications never experience instantaneous full load steps and the IC's high switching frequency and fast transient response can easily control voltage regulation at all times. Therefore, sag and soar are seldom an issue except in very low-voltage CPU core or DDR memory supply applications, particularly for devices with high clock frequencies and quick changes into and out of sleep modes. In such applications, simply increasing the amount of ceramic output capacitor (sag and soar are directly proportional to capacitance) or adding extra bulk capacitance can easily eliminate any excessive voltage transients.

In any application with large quick transients, it should calculate soar and sag to make sure that over-voltage protection and under-voltage protection will not be triggered.

Thermal Considerations

The junction temperature should never exceed the absolute maximum junction temperature $T_{J(MAX)}$, listed under Absolute Maximum Ratings, to avoid permanent damage to the device. The maximum allowable power dissipation depends on the thermal resistance of the IC package, the PCB layout, the rate of surrounding airflow, and the difference between the junction and ambient temperatures. The maximum power dissipation can be calculated using the following formula :

$$P_{D(MAX)} = (T_{J(MAX)} - T_A) / \theta_{JA}$$

where $T_{J(MAX)}$ is the maximum junction temperature, T_A is the ambient temperature, and θ_{JA} is the junction-to-ambient thermal resistance.

For continuous operation, the maximum operating junction temperature indicated under Recommended Operating Conditions is 125°C. The junction-to-ambient thermal resistance, θ_{JA} , is highly package dependent. For a UQFN-12HL 3x3 (FC) package, the thermal resistance, θ_{JA} , is 34.3°C/W on a standard JEDEC 51-7 high effective-thermal-conductivity four-layer test board. The maximum power dissipation at $T_A = 25^\circ\text{C}$ can be calculated as below :

$$P_{D(MAX)} = (125^\circ\text{C} - 25^\circ\text{C}) / (34.3^\circ\text{C/W}) = 2.9\text{W for a UQFN-12HL 3x3 (FC) package.}$$

The maximum power dissipation depends on the operating ambient temperature for the fixed $T_{J(MAX)}$ and the thermal resistance, θ_{JA} . The derating curves in Figure 3 allows the designer to see the effect of rising ambient temperature on the maximum power dissipation.

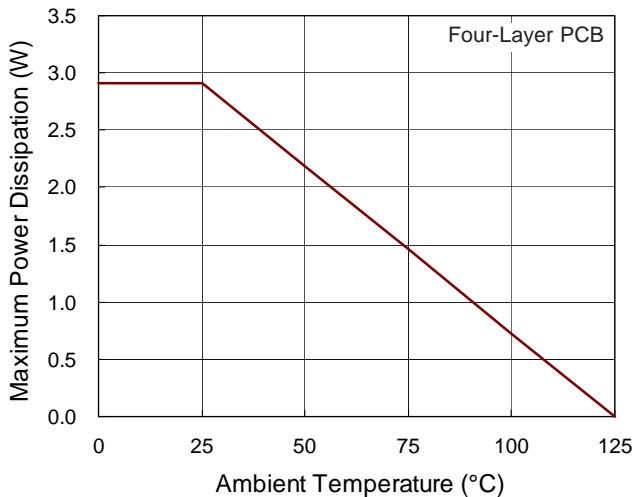

Figure 3. Derating Curve of Maximum Power Dissipation

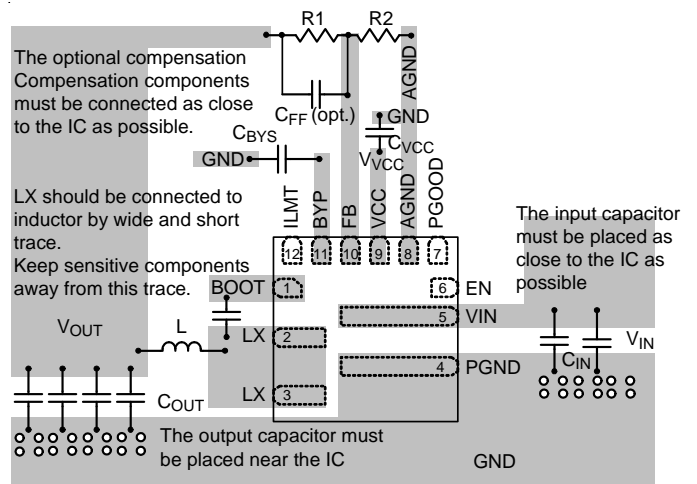

Figure 4. PCB Layout Guide

Layout Considerations

Layout is very important in high frequency switching converter design. The PCB can radiate excessive noise and contribute to converter instability with improper layout. Certain points must be considered before starting a layout using the IC.

- ▶ Make traces of the high current paths as short and wide as possible.
- ▶ Put the input capacitor as close as possible to the device pins (VIN and GND).
- ▶ The LX node encounters high frequency voltage swings so it should be kept in a small area. Keep sensitive components away from the LX node to prevent stray as possible.
- ▶ The GND pin should be connected to a strong ground plane for heat sinking and noise protection.
- ▶ Avoid using vias in the power path connections that have switched currents (from CIN to GND and CIN to VIN) and the switching node (LX).

An example of PCB layout guide is shown in Figure 4 for reference.

Outline Dimension

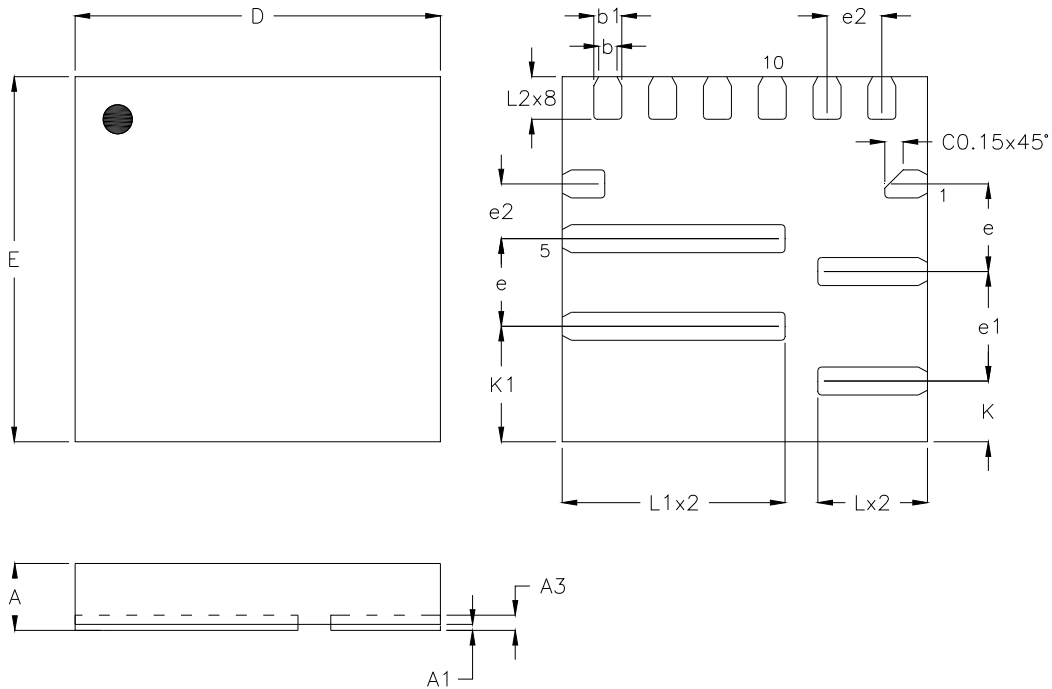

Symbol	Dimensions In Millimeters		Dimensions In Inches	
	Min	Max	Min	Max
A	0.500	0.600	0.020	0.024
A1	0.000	0.050	0.000	0.002
A3	0.100	0.200	0.004	0.008
D	2.900	3.100	0.114	0.122
E	2.900	3.100	0.114	0.122
b	0.100	0.200	0.004	0.008
b1	0.180	0.280	0.007	0.011
L	0.800	1.000	0.031	0.039
L1	1.730	1.930	0.068	0.076
L2	0.250	0.450	0.010	0.018
e	0.720		0.028	
e1	0.900		0.035	
e2	0.450		0.018	
K	0.500		0.020	
K1	0.950		0.037	

U-Type 12HL QFN 3x3 (FC) Package

Footprint Information

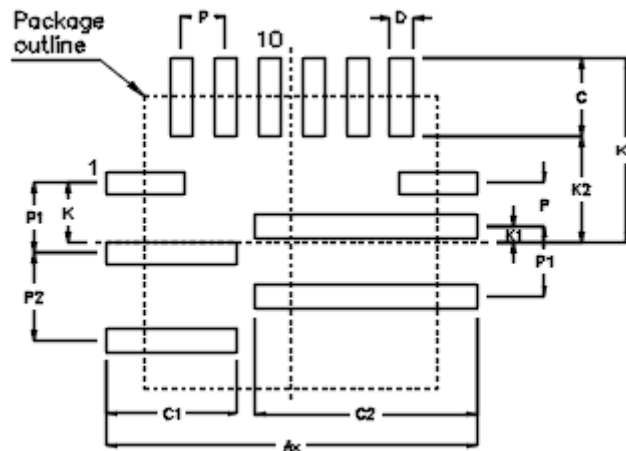

Package	Number of Pin	Footprint Dimension (mm)											Tolerance	
		P	P1	P2	A _x	C*8	C1*2	C2*2	D*12	K	K1	K2		K3
UQFN3*3-12H(FC)	12	0.450	0.720	0.900	3.800	0.800	1.350	2.280	0.230	0.619	0.169	1.100	1.900	±0.050



Richtek Technology Corporation

14F, No. 8, Tai Yuen 1st Street, Chupei City
 Hsinchu, Taiwan, R.O.C.
 Tel: (8863)5526789

Richtek products are sold by description only. Richtek reserves the right to change the circuitry and/or specifications without notice at any time. Customers should obtain the latest relevant information and data sheets before placing orders and should verify that such information is current and complete. Richtek cannot assume responsibility for use of any circuitry other than circuitry entirely embodied in a Richtek product. Information furnished by Richtek is believed to be accurate and reliable. However, no responsibility is assumed by Richtek or its subsidiaries for its use; nor for any infringements of patents or other rights of third parties which may result from its use. No license is granted by implication or otherwise under any patent or patent rights of Richtek or its subsidiaries.

Looking for pricing, stock, or lifecycle information?

Click below to explore more details on WIN SOURCE:

-  [View RT6250BHGQUF on WIN SOURCE](#)
-  [Richtek USA Inc. Information](#)

Optimize Your Supply Chain with WIN SOURCE Solutions

-  Global Sourcing Solution
-  Obsolete Management
-  Cost Control Management
-  Shortage Management
-  Alternative Solution
-  Excess Inventory Management