



**THE DATASHEET OF
TPS990STPZPRQ1**



TPS99000S-Q1 System Management and Illumination Controller

1 Features

- Qualified for automotive applications
- AEC-Q100 qualified with the following results:
 - Temperature grade 2: –40°C to 105°C ambient operating temperature
 - Device HBM ESD classification level 2
 - Device CDM ESD classification level C4B
- **Functional Safety Quality-Managed**
 - Documentation available to aid ISO 26262 functional safety system design up to ASIL-B
- Automotive system management device for TI DLP® Products:
 - Advanced power monitoring, sequencing, and protection circuits
 - Two die temperature monitors, MCU external watchdog timer, clock frequency monitor
 - System over-brightness detection
 - SPI port with parity, checksum, and password register protection
 - Second SPI port for independent system monitoring
- On-chip DMD mirror voltage regulators
 - Generates +16-V, +8.5-V and –10-V DMD control voltages
- High dynamic range dimming and color control, enabling > 5000:1 dimming range with high bit depth and white color balance:
 - Two transimpedance amplifiers (TIA) with wide dynamic range supporting numerous optical designs
 - 12-bit ADC with up to 63 time sequence samples per frame
 - DAC and comparator functions for color and pulse control
 - FET drivers for LED and shunt control

2 Applications

- **Wide field of view and augmented reality head-up display (HUD) systems**
- Digital cluster, navigation, and infotainment windshield displays

3 Description

The TPS99000S-Q1 system management and illumination controller is part of the DLP553x-Q1 chipset, which also includes the DLPC230S-Q1 DMD display controller. The chipset provides all functions needed to support and exceed typical 5000:1 display dimming requirements for Head-Up Display (HUD) applications, with typical requirements of 3 to 15,000 nits brightness range and tight color point control.

An integrated DMD high-voltage regulator supplies DMD mirror reference voltages, meeting the required tight tolerances. The power supply sequencer and monitor provide robust coordination of power-up and power-down events for the entire chipset.

The TPS99000S-Q1 illumination controller integrates a 12-bit ADC, two DACs (12-bit and 10-bit), and two high-performance photodiode signal conditioning transimpedance amplifiers (TIAs) as the core components of the illumination control system. The ADC is capable of automatic sampling up to 63 events per video frame.

Advanced system status monitoring circuits provide real-time visibility into display sub-system operational condition, including two processor watchdog circuits, two die temperature monitors, comprehensive supply monitoring for overvoltage and undervoltage detection, checksum and password register protection with byte-level parity on SPI bus transactions, an excessive brightness monitor circuit, and other built-in test functions.

Device Information

PART NUMBER	PACKAGE ⁽¹⁾	BODY SIZE (NOM)
TPS99000S-Q1	HTQFP (100)	14.00 mm × 14.00 mm

- (1) For all available packages, see the orderable addendum at the end of the data sheet.

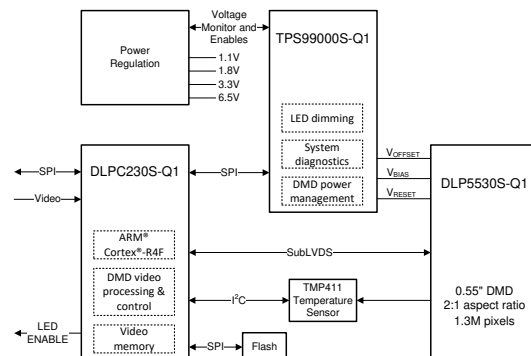

Typical Standalone System



Table of Contents

1 Features	1	6.15 Timing Requirements - Sequencer Clock.....	24
2 Applications	1	6.16 Timing Requirements - Host / Diagnostic Port SPI Interface.....	25
3 Description	1	6.17 Timing Requirements - ADC Interface.....	25
4 Revision History	2	6.18 Switching Characteristics.....	25
5 Pin Configuration and Functions	3	7 Detailed Description	27
Pin Functions - Initialization, Clock, and Diagnostics.....	4	7.1 Overview.....	27
Pin Functions - Power and Ground.....	5	7.2 Functional Block Diagram.....	28
Pin Functions - Power Supply Management.....	6	7.3 Feature Description.....	29
Pin Functions - Illumination Control.....	7	7.4 Device Functional Modes.....	54
Pin Functions - Serial Peripheral Interfaces.....	8	7.5 Register Maps.....	56
Pin Functions - Analog to Digital Converter.....	9	8 Application and Implementation	59
6 Specifications	10	8.1 Application Information.....	59
6.1 Absolute Maximum Ratings.....	10	8.2 Typical Applications.....	59
6.2 ESD Ratings.....	10	9 Power Supply Recommendations	69
6.3 Recommended Operating Conditions.....	10	9.1 TPS99000S-Q1 Power Supply Architecture.....	69
6.4 Thermal Information.....	11	9.2 TPS99000S-Q1 Power Outputs.....	69
6.5 Electrical Characteristics - Transimpedance Amplifier Parameters.....	12	9.3 Power Supply Architecture.....	69
6.6 Electrical Characteristics - Digital to Analog Converters.....	14	10 Layout	73
6.7 Electrical Characteristics - Analog to Digital Converter.....	15	10.1 Layout Guidelines.....	73
6.8 Electrical Characteristics - FET Gate Drivers.....	16	11 Device and Documentation Support	78
6.9 Electrical Characteristics - Photo Comparator.....	16	11.1 Device Support.....	78
6.10 Electrical Characteristics - Voltage Regulators.....	17	11.2 Receiving Notification of Documentation Updates..	78
6.11 Electrical Characteristics - Temperature and Voltage Monitors.....	18	11.3 Support Resources.....	78
6.12 Electrical Characteristics - Current Consumption...	19	11.4 Trademarks.....	78
6.13 Power-Up Timing Requirements.....	20	11.5 Electrostatic Discharge Caution.....	78
6.14 Power-Down Timing Requirements.....	22	11.6 Glossary.....	78
		12 Mechanical, Packaging, and Orderable Information	79

4 Revision History

DATE	REVISION	NOTES
October 2020	*	Initial Release

5 Pin Configuration and Functions

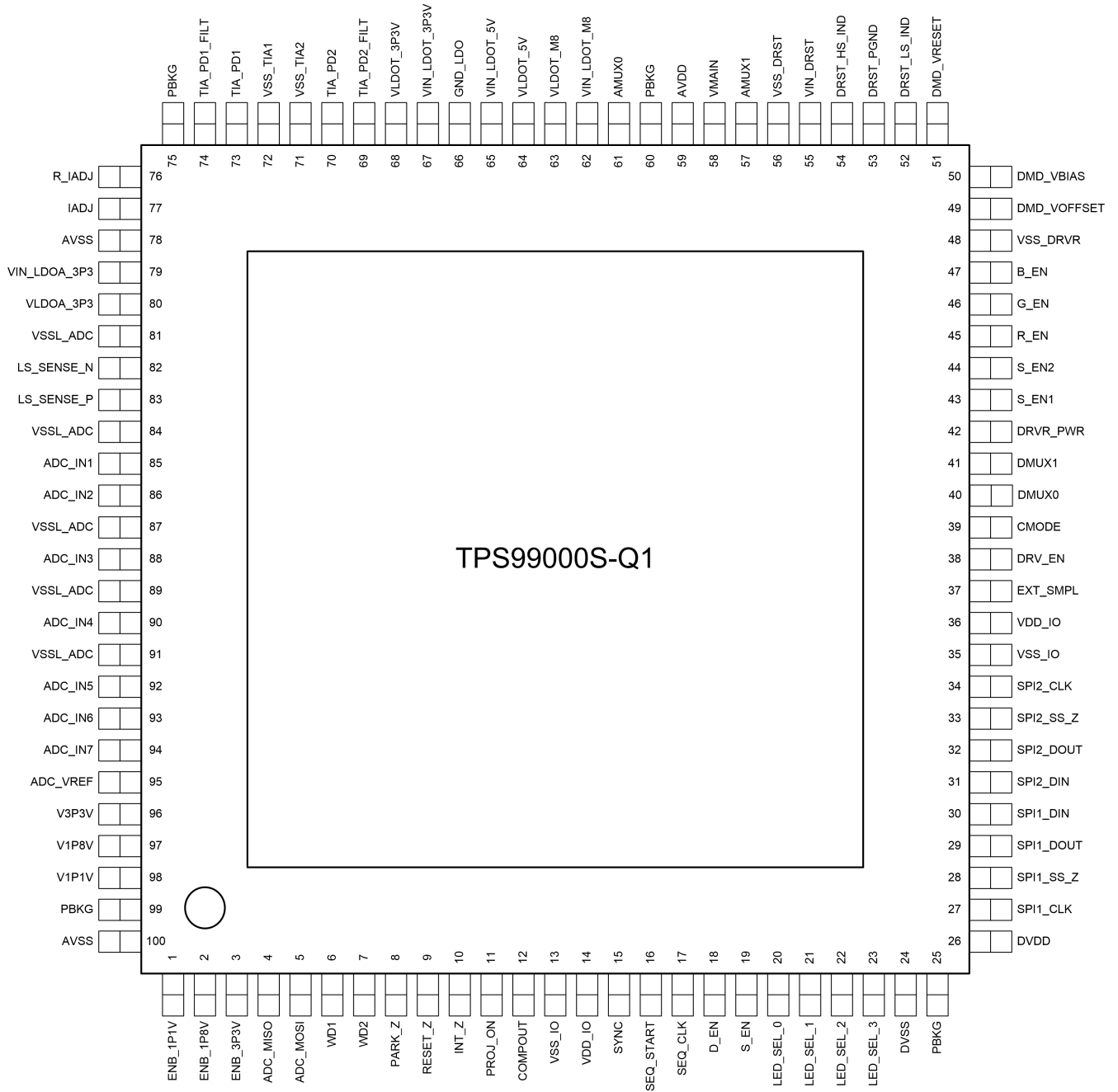

Figure 5-1. PZP Package 100-Pin HTQFP Top View

Pin Functions - Initialization, Clock, and Diagnostics

PIN		TYPE	DESCRIPTION
NO.	NAME		
6	WD1	I	Watch Dog Interrupt Channel 1
7	WD2	I	Watch Dog Interrupt Channel 2
8	PARK_Z	O	DMD Mirror Parking Signal (active low)
9	RESET_Z	O	Reset output to the DLPC230S-Q1. TPS99000S-Q1 controlled.
10	INT_Z	O	Interrupt output signal to DLPC230S-Q1 (open drain). Recommended to pull up to the DLPC230S-Q1 3.3 V rail controlled by the TPS99000S-Q1 's ENB_3P3V signal.
11	PROJ_ON	I	Input signal to enable/disable the IC and DLP projector
16	SEQ_START	I	PWM Shadow Latch Control; indicates a Start of Sequence
17	SEQ_CLK	I	Sequencer Clock
40	DMUX0	O	Digital test point output
41	DMUX1	O	Digital test point output
57	AMUX1	O	Analog Test Mux Output 1
61	AMUX0	O	Analog Test Mux Output 0

Pin Functions - Power and Ground

PIN		TYPE	DESCRIPTION
NO.	NAME		
13, 35	VSS_IO	GND	Ground Connection for Digital IO Interface
14, 36	VDD_IO	POWER	3.3 V power input for IO rail supply
24	DVSS	GND	Digital Core Ground Return
25, 60, 75, 99	PBKG	GND	Substrate Tie and ESD Ground Return
26	DVDD	POWER	3.3 V power input for digital core supply
42	DRVR_PWR	POWER	6 V or 3.3 V power input for FET driver power. Supply for S_EN1, S_EN2, R_EN, G_EN, & B_EN outputs
48	VSS_DRVR	GND	Ground Connection for FET driver power
49	DMD_VOFFSET	POWER	VOFFSET output rail. Connect a 1µF ceramic capacitor to ground
50	DMD_VBIAS	POWER	VBIAS output rail. Connect a 0.47µF ceramic capacitor to ground
51	DMD_VRESET	POWER	VRESET output rail. Connect a 1µF ceramic capacitor to ground. Connect to DRST_HS_IND through external diode. Connect anode of diode to DMD_VRESET.
53	DRST_PGND	GND	Power ground for DMD power supply. Connect to ground plane
55	VIN_DRST	POWER	6 V input for DMD power supply
56	VSS_DRST	GND	Ground Supply for DMD power supply
59	AVDD	POWER	3.3 V power supply input for analog circuit
63	VLDOT_M8	POWER	Dedicated TIA Interface –8 V LDO output
64	VLDOT_5V	POWER	Filter Cap Interface for 5 V TIA LDO
65	VIN_LDOT_5V	POWER	6 V power input for 5 V TIA LDO
66	GND_LDO	GND	Power ground return for LDO
67	VIN_LDOT_3P3V	POWER	6 V power input for 3.3 V TIA LDO
68	VLDOT_3P3V	POWER	Filter Cap Interface for 3.3 V TIA LDO
71	VSS_TIA2	GND	TIA2 Dedicated Ground
72	VSS_TIA1	GND	TIA1 Dedicated Ground
78, 100	AVSS	GND	Analog Ground
79	VIN_LDOA_3P3	POWER	6 V power input for dedicated ADC interface 3.3 V LDO supply
80	VLDOA_3P3	POWER	Dedicated ADC Interface 3.3 V LDO Filter Cap Output
81, 84, 87, 89, 91	VSSL_ADC	GND	External ADC Channel Bondwire and Lead Frame Isolation Ground
95	ADC_VREF	POWER	ADC Reference voltage output

Pin Functions - Power Supply Management

PIN		TYPE	DESCRIPTION
NO.	NAME		
1	ENB_1P1V	O	External 1.1 V Buck Enable. 3.3 V Output
2	ENB_1P8V	O	External 1.8 V Buck Enable. 3.3 V Output
3	ENB_3P3V	O	External 3.3 V Buck Enable. 3.3 V Output
52	DRST_LS_IND	ANA	Connection for the DMD power supply inductor (10 μ H). Connect a 330pF 50 V capacitor to ground. X7R recommended
54	DRST_HS_IND	ANA	Connection for the DMD power supply inductor (10 μ H)
58	VMAIN	I	Main intermediate voltage monitor input. Use external resistor divider to set voltage input for brownout monitoring
62	VIN_LDOT_M8	O	Dedicated TIA Interface –8 V LDO external regulation FET drive signal
96	V3P3V	I	External 3.3 V Buck Voltage Monitor Input
97	V1P8V	I	External 1.8 V Buck Voltage Monitor Input
98	V1P1V	I	External 1.1 V Buck Voltage Monitor Input

Pin Functions - Illumination Control

PIN		TYPE	DESCRIPTION
NO.	NAME		
12	COMPOUT	O	Photodiode (PD) Interface High-speed comparator output
15	SYNC	O	External LED buck driver sync strobe output
18	D_EN	I	LED Interface; Buck High-Side FET Drive Enable
19	S_EN	I	LED Bypass Shunt Strobe Input
20	LED_SEL_0	I	LED Enable Strobe 0 Input
21	LED_SEL_1	I	LED Enable Strobe 1 Input
22	LED_SEL_2	I	LED Enable Strobe 2 Input
23	LED_SEL_3	I	LED Enable Strobe 3 Input
37	EXT_SMPL	I	Reserved. Connect to ground
38	DRV_EN	O	Drive enable for LM3409
39	CMODE	O	Capacitor selection output (allows for a smaller capacitance to be used in CM mode for less over/under shoot). Open drain
43	S_EN1	O	Low resistance shunt NFET drive enable [High means shunt active]
44	S_EN2	O	High resistance shunt NFET drive enable [High means shunt active]
45	R_EN	O	Red channel select. Drive for low side NFET
46	G_EN	O	Green channel select. Drive for low side NFET
47	B_EN	O	Blue channel select. Drive for low side NFET
69	TIA_PD2_FILT	O	TIA2 External Filter Cap - Low Bandwidth Sampling
70	TIA_PD2	I	TIA2 Photodiode Cathode Driver
73	TIA_PD1	I	TIA1 Photodiode Cathode Driver
74	TIA_PD1_FILT	O	TIA1 External Filter Cap - Low Bandwidth Sampling
76	R_IADJ	ANA	External resistance for IADJ voltage to current transformation
77	IADJ	ANA	Current output used to adjust external LED controller drive current set point

Pin Functions - Serial Peripheral Interfaces

PIN		TYPE	DESCRIPTION
NO.	NAME		
27	SPI1_CLK	I	SPI Control interface (DLPC230S-Q1 Master, TPS99000S-Q1 slave), clock input
28	SPI1_SS_Z	I	SPI Control interface (DLPC230S-Q1 Master, TPS99000S-Q1 slave), chip select (active low)
29	SPI1_DOUT	O	SPI Control interface (DLPC230S-Q1 Master, TPS99000S-Q1 slave), Transmit data output
30	SPI1_DIN	I	SPI Control interface (DLPC230S-Q1 Master, TPS99000S-Q1 slave), Receive data input
31	SPI2_DIN	I	SPI Diagnostic Port (slave), Receive data input. For read-only monitoring
32	SPI2_DOUT	O	SPI Diagnostic Port (slave), Transmit data output. For read-only monitoring
33	SPI2_SS_Z	I	SPI Diagnostic Port (slave), chip select (active low). For read-only monitoring
34	SPI2_CLK	I	SPI Diagnostic Port (slave), clock input. For read-only monitoring

Pin Functions - Analog to Digital Converter

PIN		TYPE	DESCRIPTION
NO.	NAME		
4	ADC_MISO	O	ADC 2-wire Interface - data Output. DLPC230S-Q1 master, TPS99000S-Q1 slave.
5	ADC_MOSI	I	ADC 2-wire Interface - data Input. DLPC230S-Q1 master, TPS99000S-Q1 slave.
82	LS_SENSE_N	I	Low side current sense ADC negative input, see Table 7-2
83	LS_SENSE_P	I	Low side current sense ADC positive input, see Table 7-2
85	ADC_IN1	I	External ADC Channel 1, see Table 7-2
86	ADC_IN2	I	External ADC Channel 2, see Table 7-2
88	ADC_IN3	I	External ADC Channel 3, see Table 7-2
90	ADC_IN4	I	External ADC Channel 4, see Table 7-2
92	ADC_IN5	I	External ADC Channel 5, see Table 7-2
93	ADC_IN6	I	External ADC Channel 6, see Table 7-2
94	ADC_IN7	I	External ADC Channel 7, see Table 7-2

6 Specifications

6.1 Absolute Maximum Ratings

over operating free-air temperature range (unless otherwise noted)⁽¹⁾

		MIN	MAX	UNIT
Input voltage	VDD_IO to VSS_IO	-0.3	4	V
	DVDD to DVSS	-0.3	4	
	AVDD to DVSS	-0.3	4	
	All "VSS" to other "VSS" (grounds)	-0.1	0.1	
	All digital input signals to ground (WD1, WD2, ADC_MOSI, PROJ_ON, SEQ_START, SEQ_CLK, SPI1_CLK, SPI1_DIN, SPI1_SS, SPI2_DIN, SPI2_CLK, SPI2_SS, EXT_SMPL)	-0.3	3.6	
	DRVR_PWR to ground	-0.3	7.5	
	VIN_LDO_5V	-0.3	7.5	
	V3P3V to ground	-0.3	5	
	V1P8V to ground	-0.3	5	
	V1P1V to ground	-0.3	5	
	VIN_LDOA_3P3 to ground	-0.3	7.5	
	VIN_LDOT_3P3 to ground	-0.3	7.5	
	ADC_IN(7:1) to ground	-0.3	3.6	
	LS_SENSE_N and LS_SENSE_P to ground	-0.3	3.6	
	IADJ to ground	-0.3	18	
	R_IADJ to ground	-0.3	5	
	VIN_LDOT_M8 to ground	-18	0.3	
	DRST_LS_IND to DRST_PGND	-0.3	27	
	VIN_DRST to ground	-0.3	7.5	
	VMAIN	-0.3	7.5	
Outputs	INT_Z	-0.3	7.5	V
Operating junction temperature, T _J		-40	130	°C
Storage temperature, T _{stg}		-65	150	°C

- (1) Stresses beyond those listed under *Absolute Maximum Ratings* may cause permanent damage to the device. These are stress ratings only, which do not imply functional operation of the device at these or any other conditions beyond those indicated under *Recommended Operating Conditions*. Exposure to absolute-maximum-rated conditions for extended periods may affect device reliability.

6.2 ESD Ratings

			VALUE	UNIT
V _(ESD) Electrostatic discharge	Human-body model (HBM), per AEC Q100-002 ⁽¹⁾		±2000	V
	Charged-device model (CDM), per AEC Q100-011	All pins	±500	
		Corner pins	±750	

- (1) AEC Q100-002 indicates that HBM stressing shall be in accordance with the ANSI/ESDA/JEDEC JS-001 specification.

6.3 Recommended Operating Conditions

over operating free-air temperature range (unless otherwise noted)

		MIN	NOM	MAX	UNIT
TEMPERATURE					
T _A	Operating ambient temperature ⁽¹⁾	-40		105	°C
T _J	Operating junction temperature	-40		125	°C
VOLTAGE					

over operating free-air temperature range (unless otherwise noted)

		MIN	NOM	MAX	UNIT
VDD_IO	IO 3.3 V Voltage Supply	3	3.3	3.6	V
DVDD	Digital 3.3 V Supply	3	3.3	3.6	V
AVDD	Analog 3.3 V Supply	3	3.3	3.6	V
ADC	ADC(7:1) Inputs	0.1		1.6	V
VIN_DRST	DMD Reset Regulator Input	5.5	6	7	V
VIN_LDOT_5V	Power supply input to 5 V TIA LDO	5.5	6	7	V
VIN_LDOA_3P3V	Power supply input to 3.3 V ADC LDO	5.5	6	7	V
VIN_LDOT_3P3V	Power supply input to 3.3 V TIA LDO	5.5	6	7	V
DRVR_PWR	Gate driver power supply	3	6	7	V

(1) –40°C to 105°C ambient, free air convection, AEC Q100 grade 2.

6.4 Thermal Information

THERMAL METRIC ^{(1) (2)}		TPS99000S-Q1	UNIT
		PZP (HTQFP)	
		100 PINS	
$R_{\theta JC(top)}$	Junction-to-case (top) thermal resistance	6.9	°C/W
$R_{\theta JB}$	Junction-to-board thermal resistance	8.3	°C/W
ψ_{JT}	Junction-to-top characterization parameter	0.1	°C/W
ψ_{JB}	Junction-to-board characterization parameter	8.2	°C/W
$R_{\theta JC(bot)}$	Junction-to-case (bottom) thermal resistance	0.4	°C/W

- (1) For more information about traditional and new thermal metrics, see the *Semiconductor and IC Package Thermal Metrics* application report ([SPRA953](#)).
- (2) Operating ambient temperature is dependent on system thermal design. Operating junction temperature may not exceed its specified range across ambient temperature conditions.

6.5 Electrical Characteristics - Transimpedance Amplifier Parameters

over operating free-air temperature range (unless otherwise noted)

PARAMETER		TEST CONDITIONS	MIN	TYP	MAX	UNIT
TIA1 AND TIA2						
I _{IN_TOT}	TIA1 and TIA2 Combined Input Current		0		7 ⁽³⁾	mA
TRANSIMPEDANCE AMPLIFIER #1 (TIA1)						
I _{IN}	TIA Input Current	RGB trim <= 0.5x ⁽¹⁾	0	0.6	4.8	mA
C _{IN}	Total Input Capacitance ⁽²⁾	Allowable input capacitances from board, connectors, photo diode, and cables	10	50	140	pF
TRIM _{RGB}	RGB Trim, normal flux system		0.2	0.5	1	V/V
GAIN _{TOL_ABS}	TIA Gain Tolerance (absolute)	Tolerance to specified gain target per setting	-20%		20%	
GAIN _{TOL_REL}	TIA Gain Tolerance (relative)	Tolerance as a ratio to other settings		3%		
TIA1 SLEW RATE						
TIA _{SLEW1}	Low Gain Slew Rate, Output Referred	<= 96 kV/A gain	12			V/μs
TIA _{SLEW2}	High Gain Slew Rate, Output Referred	> 96 kV/A gain	5			V/μs
TIA _{DELAY}	TIA Pad to COMPOUT Pad Delay, DM min, Falling Edge	max slew rate input, 20 pF load, 100 mV minimum over trip point		40	64	ns
TIA _{DELAYCM}	TIA Pad to COMPOUT Delay. CM	CM max current			100	ns
TIA1 EFFECTIVE GAIN						
	Gain Setting 0	Trim set to 1.0	0.6	0.75	0.9	kV/A
	Gain Setting 1	Trim set to 1.0	1.2	1.5	1.8	kV/A
	Gain Setting 2	Trim set to 1.0	2.4	3	3.6	kV/A
	Gain Setting 3	Trim set to 1.0	4.8	6	7.2	kV/A
	Gain Setting 4	Trim set to 1.0	7.2	9	10.8	kV/A
	Gain Setting 5	Trim set to 1.0	9.6	12	14.4	kV/A
	Gain Setting 6	Trim set to 1.0	14.4	18	21.6	kV/A
	Gain Setting 7	Trim set to 1.0	19.2	24	28.8	kV/A
	Gain Setting 8	Trim set to 1.0	28.8	36	43.2	kV/A
	Gain Setting 9	Trim set to 1.0	38.4	48	57.6	kV/A
	Gain Setting 10	Trim set to 1.0	57.6	72	86.4	kV/A
	Gain Setting 11	Trim set to 1.0	76.8	96	115.2	kV/A
	Gain Setting 12	Trim set to 1.0	115.2	144	172.8	kV/A
	Gain Setting 13	Trim set to 1.0	230.4	288	345.6	kV/A

over operating free-air temperature range (unless otherwise noted)

PARAMETER		TEST CONDITIONS	MIN	TYP	MAX	UNIT
TRANSIMPEDANCE AMPLIFIER #2 (TIA2)						
I_{IN}	TIA Input Current	RGB trim $\leq 0.5x^{(1)}$	0		4.8	mA
$TRIM_{RGB}$	RGB Trim, normal flux system		0.2		1	V/V
TIA2 SLEW RATE						
$TIA2_{SLEW}$	Slew Rate, Output Referred	All gains	1			V/ μ s
TIA2 EFFECTIVE GAIN						
	Gain Setting 0	Trim set to 1.0	0.6	0.75	0.9	kV/A
	Gain Setting 1	Trim set to 1.0	1.2	1.5	1.8	kV/A
	Gain Setting 2	Trim set to 1.0	2.4	3	3.6	kV/A
	Gain Setting 3	Trim set to 1.0	4.8	6	7.2	kV/A
	Gain Setting 4	Trim set to 1.0	7.2	9	10.8	kV/A
	Gain Setting 5	Trim set to 1.0	9.6	12	14.4	kV/A
	Gain Setting 6	Trim set to 1.0	14.4	18	21.6	kV/A
	Gain Setting 7	Trim set to 1.0	19.2	24	28.8	kV/A
	Gain Setting 8	Trim set to 1.0	28.8	36	43.2	kV/A
	Gain Setting 9	Trim set to 1.0	38.4	48	57.6	kV/A
	Gain Setting 10	Trim set to 1.0	57.6	72	86.4	kV/A
	Gain Setting 11	Trim set to 1.0	76.8	96	115.2	kV/A
	Gain Setting 12	Trim set to 1.0	115.2	144	172.8	kV/A
	Gain Setting 13	Trim set to 1.0	230.4	288	345.6	kV/A

- (1) Maximum input current decreases linearly in proportion to the selected trim value, with a lower maximum value of 2.4 mA occurring when the trim is 1.0x.
- (2) Large capacitive loads could impact system performance.
- (3) For applications requiring greater than 7 mA combined TIA current, contact TI for details.

6.6 Electrical Characteristics - Digital to Analog Converters

over operating free-air temperature range (unless otherwise noted)

PARAMETER		TEST CONDITIONS	MIN	TYP	MAX	UNIT
PHOTO FEEDBACK 12 BIT DAC						
V _{OUTDAC Max}	Output Range max		1.96	2	2.04	V
V _{OUTDAC Min}	Output Range min		-0.1	0	0.1	V
t _{SET}	Settling Time	Full-range step response, To within ±2%	0		500	ns
INL	Integral Non-Linearity		-3.5		3.5	LSB
DNL	Differential Non-Linearity		-3.5		3.5	LSB
VOFF	Offset Error		-100		100	mV
ZERO _{ERR}	Zero-scale Error		-100		100	mV
GAIN _{ERR}	Gain Error		-5		5	%V/code
FS _{ERR}	Full-scale Error		-2		2	%FSR
ZERO _{ERRDFT}	Zero-scale Error Drift		-50	20	50	µV/°C
GAIN _{TEMP}	Gain Temperature Coefficient		-52	0	52	ppm FSR/°C
CURRENT CONTROL 10 BIT DAC						
V _{OUTDAC Max}	Output Range max		1.96	2	2.04	V
V _{OUTDAC Min}	Output Range min		-0.1	0	0.1	V
t _{SET}	Settling Time	Full-range step response to within ±2%	0		1000	ns
INL	Integral Non-Linearity		-2		2	LSB
DNL	Differential Non-Linearity		-2		2	LSB
V _{OFF}	Offset Error		-100		100	mV
ZERO _{ERR}	Zero-scale Error		-100		100	mV
GAIN _{ERR}	Gain Error		-5		5	%V/code
FS _{ERR}	Full-scale Error		-2		2	%FSR
ZERO _{ERRDFT}	Zero-scale Error Drift		-50	20	50	µV/°C
GAIN _{TEMP}	Gain Temperature Coefficient		-52	0	52	ppm FSR/°C
OVERBRIGHTNESS DETECTOR 8 BIT DAC						
V _{OUTDAC max}	Output Range max		1.95	2	2.05	V
V _{OUTDAC min}	Output Range min		-0.1	0	0.1	V
t _{OB DAC}	Over-brightness DAC Adjustment Time	From input code mux input change to 90/10 settling at analog output			1000	µs
INL	Integral Non-Linearity		-1		1	LSB
DNL	Differential Non-Linearity		-0.5		0.5	LSB
V _{OFF}	Offset Error		-100		100	mV
ZERO _{ERR}	Zero-scale Error		-100		100	mV
GAIN _{ERR}	Gain Error		-5		5	%V/code
FS _{ERR}	Full-scale Error		-3		3	%FSR
ZERO _{ERRDFT}	Zero-scale Error Drift		-50	20	50	µV/°C
GAIN _{TEMP}	Gain Temperature Coefficient		-52	0	52	ppm FSR/°C

6.7 Electrical Characteristics - Analog to Digital Converter

over operating free-air temperature range (unless otherwise noted)

PARAMETER		TEST CONDITIONS	MIN	TYP	MAX	UNIT
12 BIT ADC ⁽¹⁾						
V _{INPUT}	Input Range ⁽²⁾		0.1		1.6	V
INL	Integral Non-Linearity	Over valid input range V _{INPUT}	-4		4	LSB
DNL	Differential Non-Linearity		-2.5		2.5	LSB
ENOB	Effective Number Of Bits		10	12		bits
t _{SAMPLE}	S/H Sampling Period		0.4	5.2	12.8	μs
t _{DELAY}	S/H Delay before conversion starts		0.4		2.8	μs
t _{SHOLD}	S/H Holding Period			102.4	245	μs
t _{CONV}	Conversion Period			102.4		μs
V _{REF}	Measurement Reference	ADC reference voltage is doubled to 1.6 V	0.784	0.8	0.816	V
V _{OFFS}	Offset		-20		20	LSB
	Gain Error	"ADC_IN(7:1) Inputs	2		2	%FSR

(1) ADC specifications refer to ADC core behavior, presume ideal clocks and IC input power conditions, unless otherwise noted.

(2) Results in invalid ADC codes below 256.

6.8 Electrical Characteristics - FET Gate Drivers

over operating free-air temperature range (unless otherwise noted)

PARAMETER		TEST CONDITIONS	MIN	TYP	MAX	UNIT
LED CONTROL SIGNAL FET GATE DRIVERS						
Q _{SEN}	S_EN1/2 Load Gate Charge			12	16.5	nC
Z _{SEN}	S_EN1/2 Pull-up Gate Drive Output Impedance	3.3 V domain ⁽¹⁾		12.3		Ω
		6 V domain ⁽²⁾		10.7		Ω
Z _{SEN}	S_EN1/2 Pull-down Gate Drive Output Impedance	3.3 V domain ⁽¹⁾		4.85		Ω
		6 V domain ⁽²⁾		4.6		Ω
T _{SEN}	S_EN1/2 Pull-up Transition Time	3.3 V domain, with max total gate charge load of 2.5 nF ⁽¹⁾	49.5	66	82.5	ns
		6 V domain, with max total gate charge load of 2.5 nF ⁽²⁾	45	60	75	ns
T _{SEN}	S_EN1/2 Pull-down Transition Time	3.3 V domain, with max total gate charge load of 2.5 nF ⁽¹⁾	20.25	27	33.75	ns
		6 V domain, with max total gate charge load of 2.5 nF ⁽²⁾	18.75	25	31.25	ns
Z _{RGB}	RGB_EN Pull-up Output Impedance	3.3 V domain ⁽¹⁾		50.8		Ω
		6 V domain ⁽²⁾		43.6		Ω
Z _{RGB}	RGB_EN Pull-down Output Impedance	3.3 V domain ⁽¹⁾		4.85		Ω
		6 V domain ⁽²⁾		4.6		Ω
T _{RGB}	RGB_EN Pull-up Falling Transition Time	3.3 V domain, with max total gate charge load of 2.5 nF ⁽¹⁾	198.75	265	331.25	ns
		6 V domain, with max total gate charge load of 2.5 nF ⁽²⁾	180	240	300	ns
T _{RGB}	RGB_EN Pull-down Falling Transition Time	3.3 V domain, with max total gate charge load of 2.5 nF ⁽¹⁾	20.25	27	33.75	ns
		6 V domain, with max total gate charge load of 2.5 nF ⁽²⁾	18.75	25	31.25	ns

(1) DRVR_PWR Supply Voltage is between 3 V and 3.6 V.

(2) DRVR_PWR Supply Voltage is between 5.5 V and 7.5 V.

6.9 Electrical Characteristics - Photo Comparator

over operating free-air temperature range (unless otherwise noted)

PARAMETER		TEST CONDITIONS	MIN	TYP	MAX	UNIT
PHOTO FEEDBACK COMPARATOR						
V _{OFF}	Offset Voltage		-10		10	mV
T _{HYST}	Hysteresis		10	20		mV

6.10 Electrical Characteristics - Voltage Regulators

over operating free-air temperature range (unless otherwise noted)

PARAMETER	TEST CONDITIONS	MIN	TYP	MAX	UNIT	
VOFFSET REGULATOR						
V _{OUT}	Output Voltage	Across load conditions	8.25	8.5	8.75	V
I _{OUT}	Output Current ⁽²⁾		0.1 ⁽⁴⁾		16.3	mA
V _{PGTHRESHR}	Powergood Threshold, V _{OUT} Rising		86%			
V _{PGTHRESHF}	Powergood Threshold, V _{OUT} Falling		66%			
C _{OUT}	Output Capacitor ⁽³⁾		1			μF
T _{DISC}	Discharge Time	C _{OUT} = 1 μF			260	μs
VBIAS REGULATOR						
V _{OUT}	Output Voltage		15.5	16	16.5	V
I _{OUT}	Output Current ⁽²⁾		0.1 ⁽⁴⁾		1.5	mA
V _{PGTHRESHR}	Powergood Threshold, V _{OUT} Rising		86%			
V _{PGTHRESHF}	Powergood Threshold, V _{OUT} Falling		66%			
C _{OUT}	Output Capacitor ⁽³⁾		0.47			μF
T _{DISC}	Discharge Time	C _{OUT} = 0.47 μF			260	μs
VRESET REGULATOR						
V _{OUT}	Output Voltage		-10.5	-10	-9.5	V
I _{OUT}	Output Current ^{(1) (2)}		-17.6		-0.1 ⁽⁴⁾	mA
V _{PGTHRESHR}	Powergood Threshold		80%			
C _{OUT}	Output Capacitor ⁽³⁾		1			μF
T _{DISC}	Discharge Time	C _{OUT} = 1 μF			260	μs
NEGATIVE 8 V PHOTO DIODE LDO						
V _{IN}	Input Voltage			-10		V
V _{OUT}	Output Voltage	Unloaded	-8.5	-8	-7.5	V
I _{OUT}	Output Current		-6			mA
V _{IRIPPLE}	Input Ripple				100	mVpp

- (1) VRESET current supplies both DMD and Negative 8-V LDO.
- (2) VOFFSET, VBIAS, and VRESET are designed to supply the DMD and Negative 8 V LDO only, and should not be connected to additional loads.
- (3) The capacitance value of some ceramic capacitor types can diminish drastically depending on the applied DC voltage and temperature. TI recommends X7R dielectric capacitors to minimize capacitance loss over voltage bias and temperatures. Using a higher voltage rated part and/or a larger package size also helps minimize the capacitance reduction at the applied DC voltage. Refer to the DLP5531Q1EVM for suggested components.
- (4) Pull down resistors required to meet minimum current requirement.

6.11 Electrical Characteristics - Temperature and Voltage Monitors

over operating free-air temperature range (unless otherwise noted)

PARAMETER		TEST CONDITIONS	MIN	TYP	MAX	UNIT
TEMPERATURE MONITOR						
TEMP _{WARN}	Thermal Warning Threshold	Junction Temperature		135		°C
TEMP _{EMRG}	Thermal Emergency Threshold	Junction Temperature		150		°C
1.1 V SUPPLY MONITOR						
V _{TRIPN}	Negative Trip Threshold	Negative going only	0.95	0.98	1.01	V
V _{TRIPHYST}	Hysteresis	Positive going threshold, amount higher than negative trip voltage		2%		
t _{GLITCH}	Glitch Suppression	Size of glitch ignored (no reset) with 2% overdrive	20		1000	µs
1.8 V SUPPLY MONITOR						
V _{TRIPN}	Negative Trip Threshold	Negative going only	1.552	1.6	1.648	V
V _{TRIPHYST}	Hysteresis	Positive going threshold, amount higher than negative trip voltage		2%		
t _{GLITCH}	Glitch Suppression	Size of glitch ignored (no reset) with 2% overdrive	20		1000	µs
3.3 V SUPPLY MONITOR						
V _{TRIPN}	Negative Trip Threshold	Negative going only	2.852	2.93	3.03	V
V _{TRIPHYST}	Hysteresis	Positive going threshold, amount higher than negative trip voltage		2%		
t _{GLITCH}	Glitch Suppression	Size of glitch ignored (no reset) with 2% overdrive	20		1000	µs
AVDD, DVDD, VDDIO SUPPLY MONITORS						
V _{TRIPN}	Negative Trip Threshold	Negative going only	2.74	2.86	2.98	V
V _{TRIPHYST}	Hysteresis	Positive going threshold, amount higher than negative trip voltage		2%		
t _{GLITCH}	Glitch Suppression	Size of glitch ignored (no reset) with 2% overdrive	20		1000	µs
VMAIN SYSTEM INPUT SUPPLY MONITOR						
V _{MAINTHRSH}	VMAIN Threshold	External resistor divider used to translate VMAIN	1.2125	1.25	1.2875	V
t _{MAINGLITCH}	VMAIN Glitch Suppression	At 2% overdrive	20		1000	µs

6.12 Electrical Characteristics - Current Consumption

PARAMETER	TEST CONDITIONS	MIN	TYP ⁽¹⁾	MAX ⁽²⁾	UNIT
SUM OF 3.3 V SUPPLY PINS: DVDD, VDD_IO, AND AVDD					
System off	PROJ_ON Low		1.5	2	mA
System on	Display On state, no TIAs enabled		3.5	4	mA
TIA #1	Additional current from enabling TIA #1		1	1	mA
TIA #2	Additional current from enabling TIA #2		1	1	mA
SUM OF 6 V SUPPLY PINS: DRVR_PWR, VIN_DRST, VIN_LDOT_5V, VIN_LDOT_3P3V, AND VIN_LDOA_3P3V					
System off	PROJ_ON Low		1	2	mA
System on ⁽³⁾	Display On state, no TIAs enabled		98	119	mA
TIA #1	Additional current from enabling TIA #1		20	25	mA
TIA #2	Additional current from enabling TIA #2		20	25	mA

- (1) Typical measurements performed at 25°C and nominal voltage.
- (2) Measurements taken at -40°C, 25°C, and 105°C. 3.3 V inputs measured at 3 V, 3.3 V, 3.6 V. 6 V inputs measured at 5.5 V, 6 V, and 7 V. The maximum current draw of all these conditions is shown.
- (3) This number represents the current at the input to the TPS99000S-Q1 when the DMD voltage rails output the maximum current as listed in the respective sections of this datasheet. This number is the combination of the measured current when the DMD voltage regulator is unloaded (35 mA typical, 56 mA max) and the estimated current draw on the 6 V supply when the DMD voltage regulator outputs the maximum current (63 mA). The estimated current draw is calculated by the equation $I_{6V} = [(16/6) \cdot I_{VBIAS} + (8.5/6) \cdot I_{VOFFSET} + (-10/6) \cdot I_{VRESET}] / \eta$ where $\eta = 0.9$. In order to calculate the power dissipation of the TPS99000S-Q1 in this condition, multiply the current from the unloaded condition by the input voltage, and add the current from the DMD voltage regulator multiplied by the input voltage multiplied by (1- η).

6.13 Power-Up Timing Requirements

			TYP	UNIT
t_{en_dly}	PROJ_ON to 1.1 V enable. This includes PROJ_ON t_{glitch} time.	Rising edge of PROJ_ON to rising edge of 1.1 V enable.	11	ms
t_{mon1} ^{(1) (2)}	Maximum time for 1.1 V rail to reach voltage threshold after enable has been asserted. This delay length will occur even if 1.1 V meets threshold earlier.	Rising edge of ENB_1P1V to internal 1.1 V monitor test.	10	ms
t_{mon2} ^{(1) (2)}	Maximum time for 1.8 V rail to reach voltage threshold after enable has been asserted. This delay length will occur even if 1.8 V meets threshold earlier.	Rising edge of ENB_1P8V to internal 1.8 V monitor test.	10	ms
t_{mon3} ^{(1) (2)}	Maximum time for 3.3 V rail to reach voltage threshold after enable has been asserted. This delay length will occur even if 3.3 V meets threshold earlier.	Rising edge of ENB_3P3V to internal 3.3 V monitor test.	10	ms
t_{w1}	RESETZ delay after voltage testing completion.	Completion of 3.3 V monitor test to RESETZ rising edge.	10	ms

- (1) V1P1V, V1P8V, and V3P3V rails can be enabled prior to the TPS99000S-Q1 assertion of their respective enable signal if required for system power design. If necessary, ENB_1P1V may be connected to the 1.1 V, 1.8 V, and 3.3 V external supply enables.
- (2) If any voltage threshold is not met within the specified time, the TPS99000S-Q1 will not de-assert RESETZ. The power-up procedure must be fully restarted in this situation.

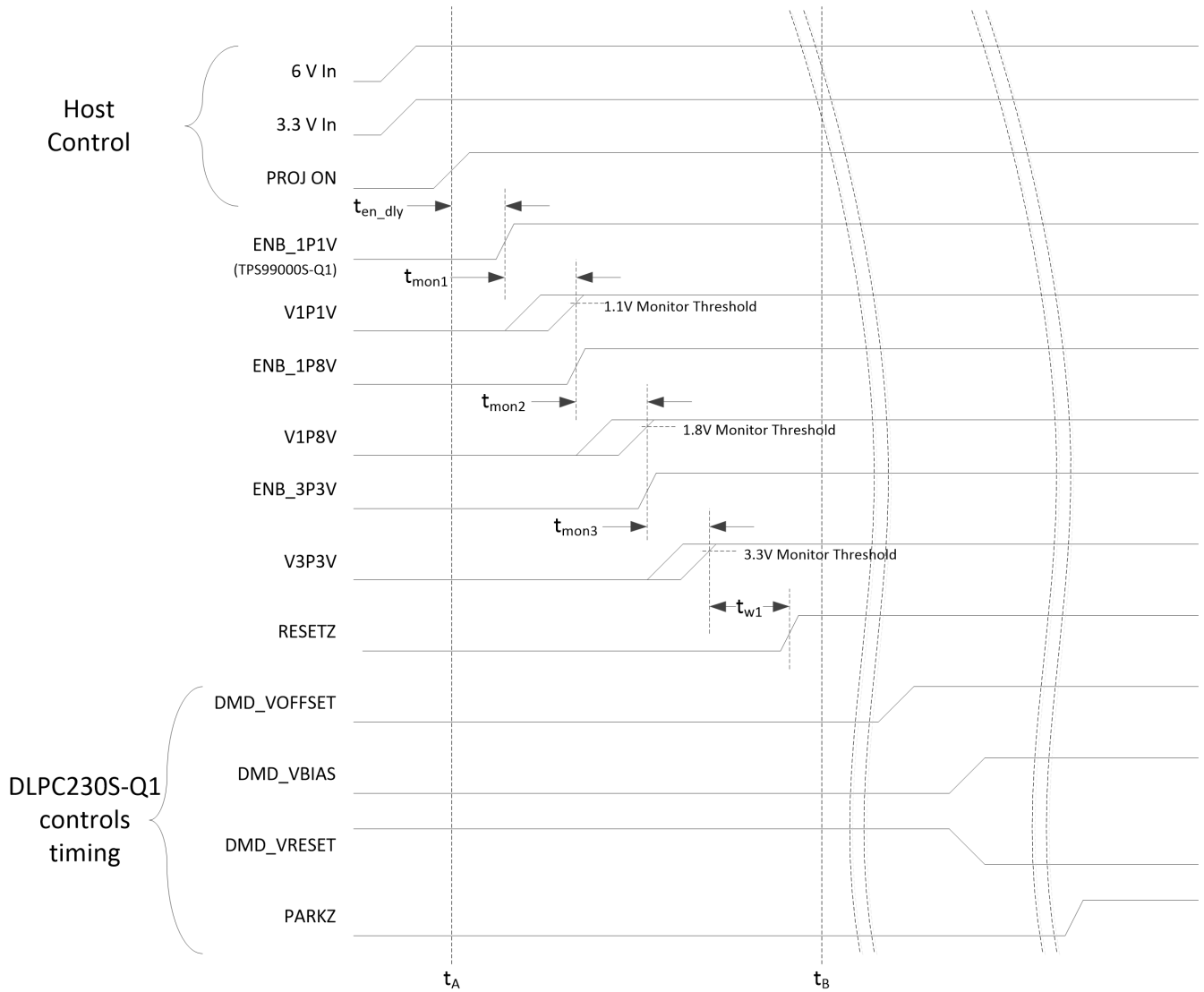

Figure 6-1. Power Up Timing

6.14 Power-Down Timing Requirements

See (1)

			MIN	MAX	UNIT
t_{vhold1}	Host voltage hold time after VMAIN minimum threshold reached. $t_{\text{mon4}}(\text{max}) + t_{\text{park}}(\text{max}) + t_{\text{w2}}(\text{max})$	VMAIN threshold to 6 V and 3.3 V power loss.(2) (3)	900		μs
t_{vhold2}	Host voltage hold time after PROJ_ON de-asserted. $t_{\text{mon5}}(\text{max}) + t_{\text{park}}(\text{max}) + t_{\text{w2}}(\text{max})$	VMAIN threshold to 6 V and 3.3 V power loss.(2) (3)	1.78		ms
t_{mon4}	VMAIN monitoring time.	Minimum voltage trip threshold to PARKZ falling edge.	52	120	μs
t_{mon5}	PROJ_ON de-assertion reaction time.	Falling edge of PROJ_ON to PARKZ falling edge.		1	ms
t_{park}	DMD Park time.	PARKZ falling edge to start DMD_VOFFSET discharge.		280	μs
$t_{\text{discharge}}$ (4)	DMD voltage rail discharge time.	VOFFSET $C_{\text{out}} = 1 \mu\text{F}$ VRESET $C_{\text{out}} = 1 \mu\text{F}$ VBIAS $C_{\text{out}} = 0.47 \mu\text{F}$		260	μs
t_{w2}	DMD voltage disable to RESETZ de-assertion.	Start of DMD voltage rail discharge to RESETZ falling edge.		500	μs

- (1) There are two methods for initiating the power down sequence:
 - a. VMAIN voltage decreases below its minimum threshold. This is typical if the TPS99000S-Q1 is expected to initiate the power down sequence when main power is removed from the system. Note that the 6 V and 3.3 V input rails must remain within operating range for a specified period of time after the power-down sequence begins.
 - b. PROJ_ON low. This allows a host controller to initiate power down through a digital input to the TPS99000S-Q1 .
- (2) 6 V input rails include DRVR_PWR, VIN_DRST, VIN_LDOT_5V, VIN_LDOA_3P3V, VIN_LDOT3P3V.
- (3) 3.3 V input rails include VDD_IO, DVDD, AVDD.
- (4) The DMD specifies a maximum absolute voltage difference between VBIAS and VOFFSET. In order to remain below this maximum voltage difference, VBIAS must discharge faster than VOFFSET. This is accomplished by using a smaller C_{out} capacitance for VBIAS in order to allow it to discharge quicker than VOFFSET.

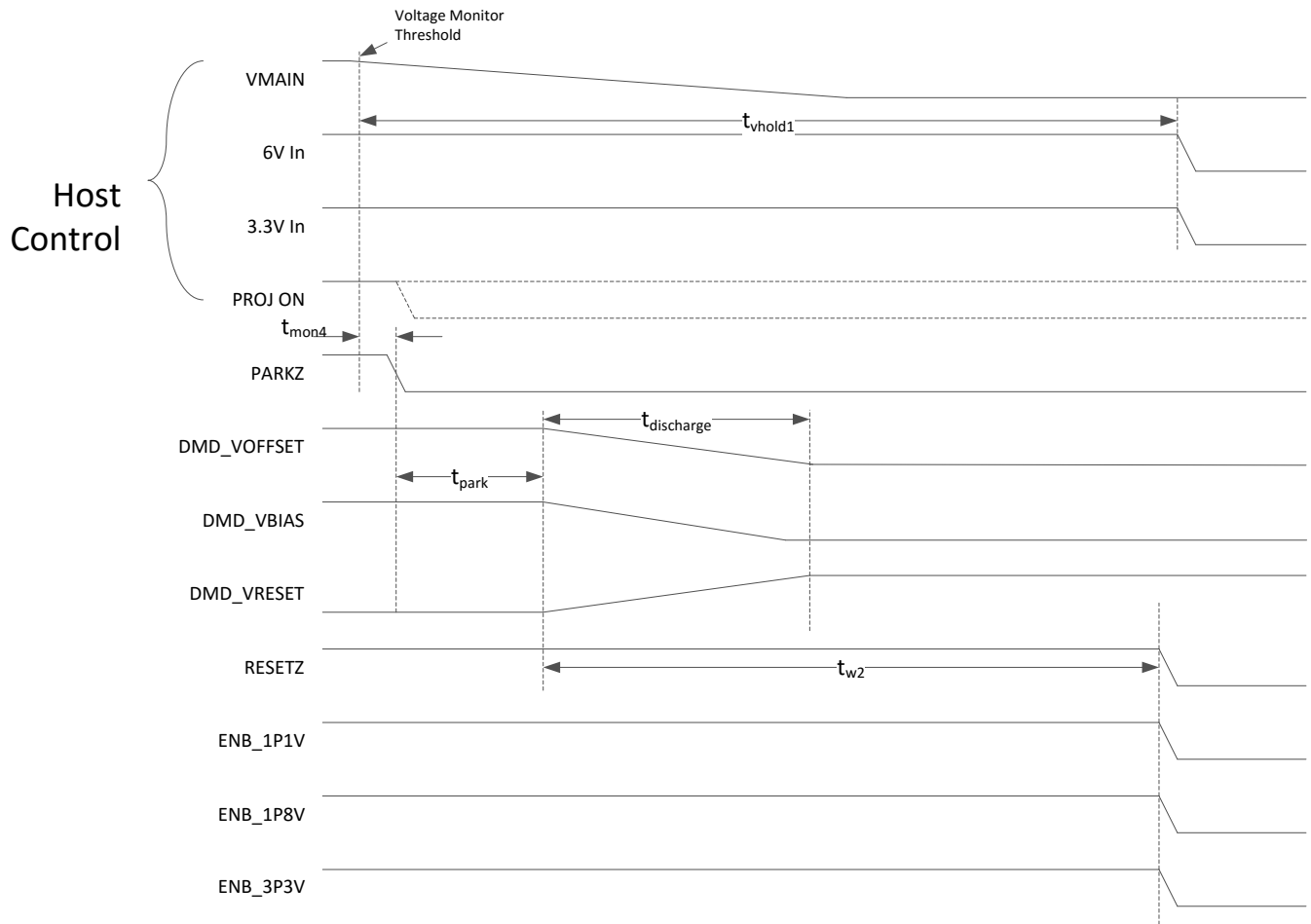

Figure 6-2. Power Down Timing - VMAIN Trigger

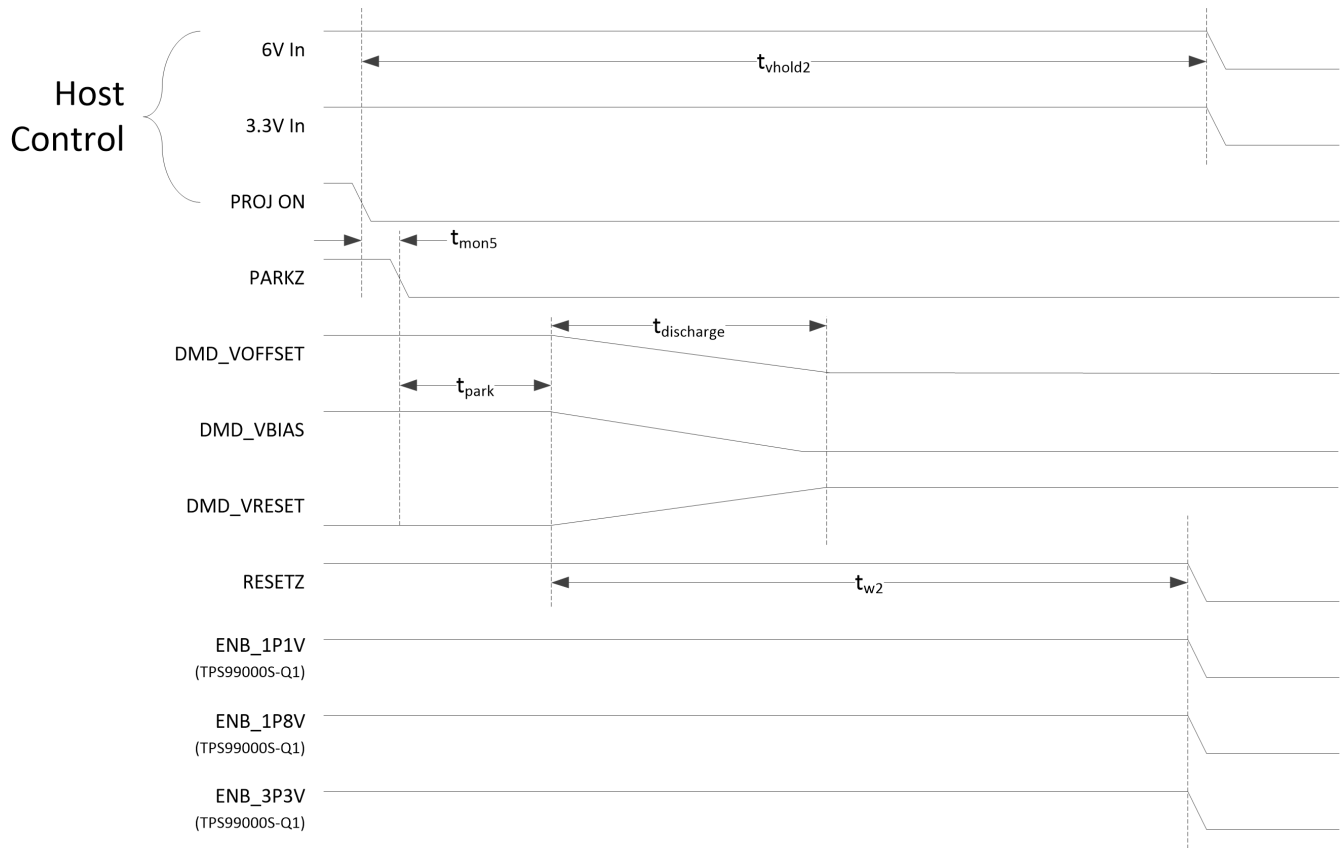

Figure 6-3. Power Down Timing - PROJ_ON Trigger

6.15 Timing Requirements - Sequencer Clock

		MIN	NOM	MAX	UNIT
f_{SEQ_CLK}	SEQ_CLK Frequency		30.00		MHz
t_{JPP}	SEQ_CLK Jitter (peak to peak)	-3%		3%	
f_{SS}	SEQ_CLK allowable spread spectrum	-2%		0%	
f_{SSMOD}	SEQ_CLK Spread Spectrum Modulation Frequency	25		100	kHz
$f_{SSSTEPS}$	SEQ_CLK Spread Spectrum Modulation Frequency Steps		50		steps

6.16 Timing Requirements - Host / Diagnostic Port SPI Interface

		MIN	NOM	MAX	UNIT
$t_{SPICPER}$	SPI CLK Cycle Time	31	33		ns
$t_{SPICHIGH}$	SPI CLK High Time	10			ns
$t_{SPICLOW}$	SPI CLK Low Time	10			ns
$t_{SPIDOUT}$	CLK Falling to DOUT	0		15	ns
$t_{SSSETUP}$	SPI SS_Z to CLK Rising Setup Time	5			ns
t_{SSHOLD}	SPI CLK Rising to SS_Z Hold Time	5			ns
$t_{DINSETUP}$	SPI DIN to CLK Rising Setup Time	5			ns
$t_{DINHOLD}$	SPI CLK Rising to DIN Hold Time	5			ns

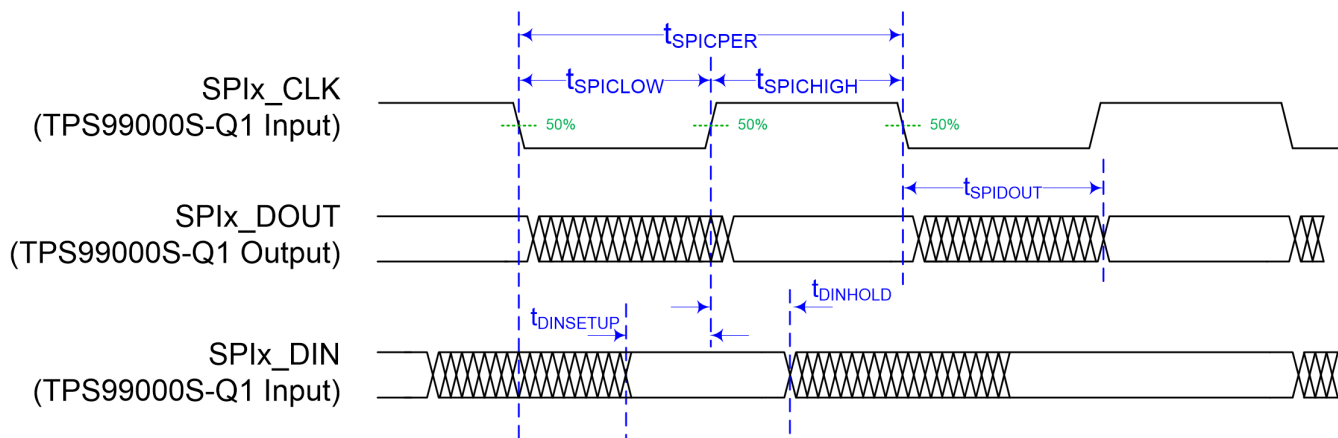

Figure 6-4. DLPC230S-Q1 Diagnostic Interface Timing

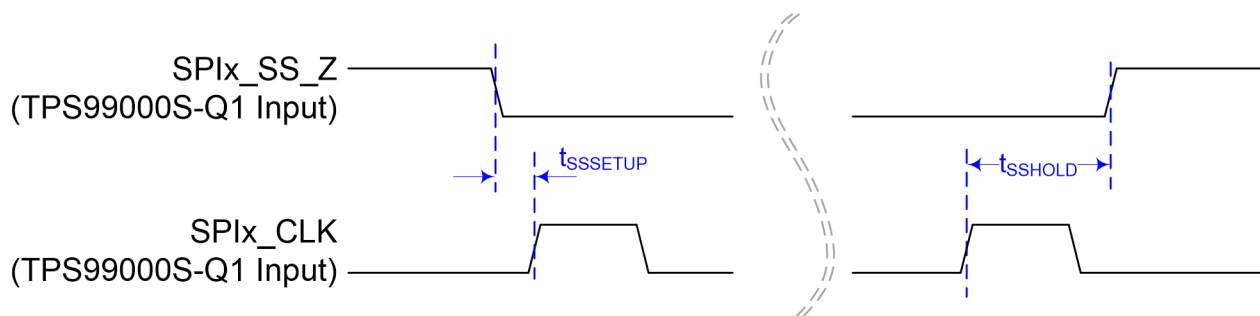

Figure 6-5. Chip Select Setup and Hold Timing

6.17 Timing Requirements - ADC Interface

		MIN	NOM	MAX	UNIT
$t_{ADCDINSETUP}$	ADC DIN to CLK Rising Setup Time	5			ns
$t_{ADCDINHOLD}$	ADC CLK Rising to DIN Hold Time	5			ns
$t_{ADCDOUT}$	CLK Rising to DOUT	0		15	ns

6.18 Switching Characteristics

over operating free-air temperature range (unless otherwise noted)

PARAMETER	TEST CONDITIONS	MIN	TYP	MAX	UNIT
INTERNAL CLOCK					

over operating free-air temperature range (unless otherwise noted)

PARAMETER		TEST CONDITIONS	MIN	TYP	MAX	UNIT
f_{osc}	Internal Oscillator Frequency		1.76	2	2.24	MHz

7 Detailed Description

7.1 Overview

The TPS99000S-Q1 is an integral component of the DLP553x-Q1 chipset, which also includes the DLPC230S-Q1 DMD display controller. It provides features to support ultra-wide dimming requirements, which are unique to automotive. The TPS99000S-Q1 also provides a high-voltage, high-precision, three-rail regulator to cost-effectively create DMD mirror control voltages (16 V, 8.5 V, –10 V). A complete system power monitor and DMD mirror parking solution is included to increase system robustness and reduce cost. In addition, the TPS99000S-Q1 includes numerous system monitoring and diagnostic features, such as configurable ADCs, TIAs, and watchdogs.

An integrated 12-bit ADC supports the illumination system control, and provides useful information about the operating condition of the system. Several external ADC channels are included for general usage (LED temperature measurement, etc). One of the external ADC channels includes a differential input amplifier and is dedicated to LED current measurement. The DLPC230S-Q1 and TPS99000S-Q1 ADC control blocks support up to 63 samples per video frame, with precise hardware alignment of samples to the DMD sequence timeline. This information is available to the color control software in the DLPC230S-Q1 where it can be used to counteract effects of temperature and LED aging to maintain brightness and white point targets.

Two SPI buses are included. The first bus is intended for command and control, and the second is a read-only bus for optional redundant system condition monitoring. The SPI ports include support for byte-level parity checking.

Two transimpedance amplifiers are included. The first TIA is dedicated to illumination control, and the second is available and reconfigurable for general usage, such as redundancy, ambient light detection, and output light validation. An over-brightness detector is included to provide a hardware redundant check of LED brightness.

Two windowed watchdog circuits are included to provide validation of DLPC230S-Q1 microprocessor operation and monitoring of DMD sequencer activity. The TPS99000S-Q1 also includes on-die temperature threshold monitoring and a monitor circuit to validate the external clock ratio (of the SEQ_CLK) against an internal oscillator.

7.2 Functional Block Diagram

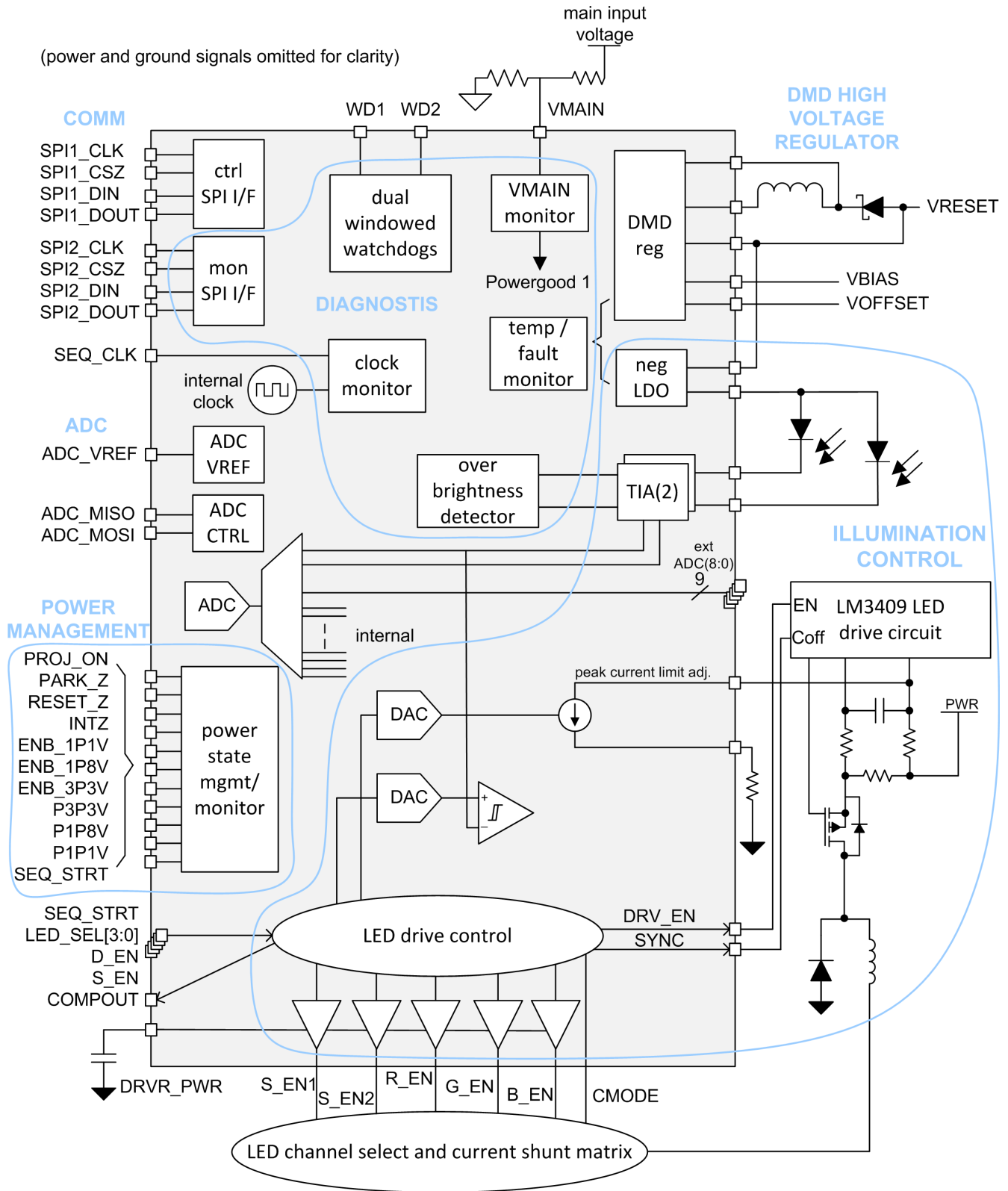

7.3 Feature Description

7.3.1 Illumination Control

The illumination control function includes all blocks needed to generate light for the DLP subsystem. The system is designed to support automotive applications requiring precise control of color and brightness over a wide dimming range. The complete dimming solution consists of hardware features included in both the DLPC230S-Q1 and TPS99000S-Q1 along with DMD sequence data stored in the DLPC230S-Q1. These elements work together to provide a usable system dimming range of over 5000:1, with up to 8 bits per color supported.

The illumination control function operates in two distinct modes to cover the full dimming range. These modes are referred to as continuous mode (CM) and discontinuous mode (DM).

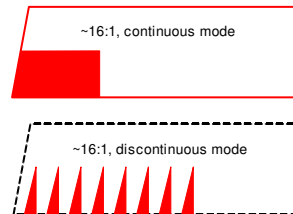

Figure 7-1. Comparison of Continuous and Discontinuous Mode Operation

Continuous mode features:

- High- to mid-brightness levels
- Rectangular light pulses created for each color
- Pulse amplitude and pulse width varied to adjust brightness level

Discontinuous mode features:

- Mid- to low-brightness levels
- A series of small triangular light pulses created for each color
- Number of pulses, pulse height, and LED current varied to adjust brightness level

The illumination control loop regulates current supplied to the LEDs through a real-time photo feedback control loop. A broadband photodiode is placed in the illumination path of the DLP subsystem in a location that receives light from all three red/green/blue LEDs. For continuous mode operation, photo feedback is used to create a real-time hysteretic control loop to set the brightness levels for each LED. In discontinuous mode, photo feedback is used to set a peak brightness threshold for each light pulse.

To support illumination control, the TPS99000S-Q1 includes numerous high performance analog and mixed signal blocks. These blocks include:

- A high performance, ultra-wide dynamic range transimpedance amplifier (TIA) to convert photodiode current to a voltage, representing real-time LED brightness
- A high-speed comparator for photo feedback control
- A 12-bit DAC for photo feedback reference
- A 10-bit DAC for peak current limit adjustment
- Sync and drive enable outputs for synchronizing an external high-side PFET buck controller (LM3409)
- External FET drivers and control logic for selection of LEDs (FETs are external, but the drivers are internal)
- Two current *shunt* (by-pass) path FET controls, used to pre-regulate inductor current while light is disabled between colors, and to enable discontinuous mode operation
- A multi-purpose 12-bit ADC block with a dedicated two wire *Kelvin* input channel specifically for measuring LED current
- Hardware sample timer block that works in conjunction with DLPC230S-Q1 to provide configurable hardware timed samples of LED current and voltage, temperature, etc.
- RGB specific multiplexed settings for most parameters, enabling independent control parameter optimization per color

7.3.1.1 Illumination System High Dynamic Range Dimming Overview

This section provides a generalized overview, describing the concepts to provide a framework for understanding how the functions within the TPS99000S-Q1 support the high dynamic dimming scheme of the full chipset and software.

A Head-Up Display (HUD) system must typically meet a target white point requirement over a wide range of brightness. Covering a wide brightness range requires a combination of continuous and discontinuous modes. Continuous mode will utilize different combinations of RGB sequence duty cycles, time attenuation, and amplitude attenuation. Discontinuous mode will utilize different combinations of the number of discrete pulses of light, photo feedback (TIA) gain, peak current limit settings, and light amplitude DAC settings. These adjustments can be categorized as coarse adjustments and fine adjustments.

Coarse adjustments include:

- **Illumination Bin** – Selects the DMD duty cycle, LED duty cycle, and the number of pulses (DM only).
- **LED Current Limits** – In CM, this specifies the maximum current each LED can operate with. Used to prevent damage to the LED. In DM, specifies pre-charge inductor current used to generate pulses. Determines shape/overshoot of pulse.
- **TIA Gain** – The TIA design supports a wide range of gain settings—14 in total—to cover a wide range of photodiode current levels. Higher gain settings result in lower LED output for a given feedback voltage.

Fine adjustments include:

- **Photo Feedback DAC Settings** – This function is implemented with a high speed 12-bit DAC. Sets the LED target amplitude.

7.3.1.2 Illumination Control Loop

Figure 7-2 shows the illumination control loop. This loop consists of the following features:

- An external buck controller (LM3409) and related discrete components which control the main LED drive PFET and controls and limits peak current using a high side sense circuit. This circuit creates a controlled current source that drives the LED high side connection (LED_ANODE).
- A 10-bit peak current limit (ILIM) adjustment DAC included in the TPS99000S-Q1.
- Synchronization logic for external LED drive buck. SYNC pin to override the *controlled off time* pin of external device, and DRV_EN to control enable of external device.
- High speed comparator, used to compare photo feedback signal to programmable reference.
- 12-bit photo feedback comparison DAC. Sets reference for LED light pulse peak threshold in both continuous and discontinuous operating modes.
- A high speed, low noise, wide dynamic range transimpedance amplifier (TIA1) used for real time photo feedback. Includes support for 0.75 V to 288 V/mA gains, with 14 discrete gain steps and additional RGB specific trim of 1.0 to 0.2 gain. (Two TIAs included. TIA1 is dedicated to illumination control function).
- Negative LDO for cost effective reverse bias of photodiodes.
- 12-bit ADC, with differential input dedicated to low side current measurements.
- External FET gate drivers for RGB channel selection and two *shunt* path selections. Shunt paths provide a conduction path around the LEDs. These paths are used to control inductor current while LEDs are not emitting light. Control logic and firmware establishes appropriate current levels in inductor prior to enabling of LED during gaps between light pulses.

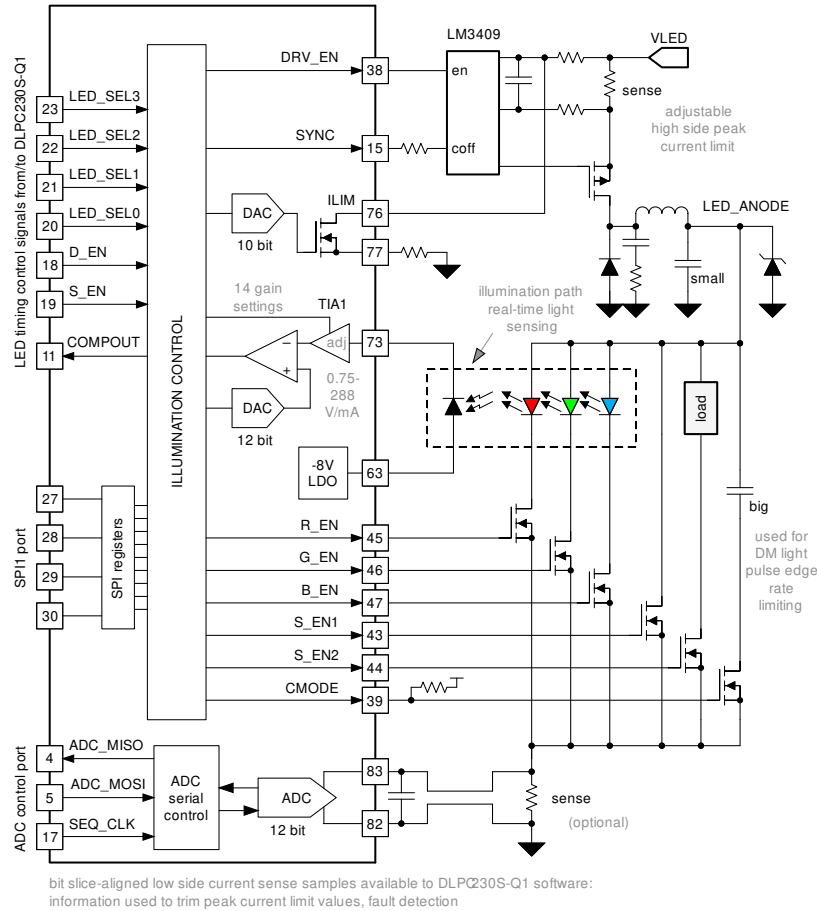

Figure 7-2. Illumination Control Loop

7.3.1.3 Continuous Mode Operation

When operating in continuous mode (continuous light output mode) a hysteretic control scheme is utilized. Real-time analog light amplitude measurements are used in the photo feedback loop to maintain a target light level. Figure 7-3 highlights the photo feedback control loop path in the driver for continuous mode.

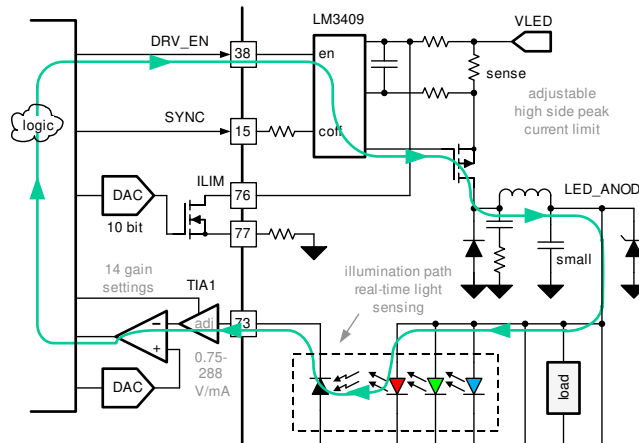

Figure 7-3. Continuous Mode Photo Feedback Path

The on-chip analog comparator of the TPS99000S-Q1 is used to compare desired target LED light amplitude to actual LED light output voltage from the photodiode TIA circuit. When the light output is below the threshold (set by the 12-bit photo feedback DAC output), the comparator will output a high level, causing DRV_EN to go high,

which creates a connection from the power rail to the LED drive inductor to be made through the LED drive PFET. This connection will cause current flow to increase through the inductor. This current flows through an LED when its FET is enabled. When the light value goes above the threshold, DRV_EN goes low and the PFET is turned off, breaking the connection to the power rail with very little delay. Once the light level drops back below the threshold, DRV_EN goes high again and the PFET is turned back on, delivering more power to the LED. This process repeats as long as the LED circuit is enabled.

Hysteretic control results in ripple in the LED current. The amplitude and frequency of this ripple is a function of inductor inductance, input voltage, comparator hysteresis, and loop latency. An advantage of this hysteretic control approach is unconditional stability of the control loop.

Figure 7-4 shows the continuous mode signals and light output for a red, green, and blue bit slice. The signals, including LED_SEL(3:0), D_EN, S_EN1, and S_EN2, are sent from the DLPC230S-Q1.

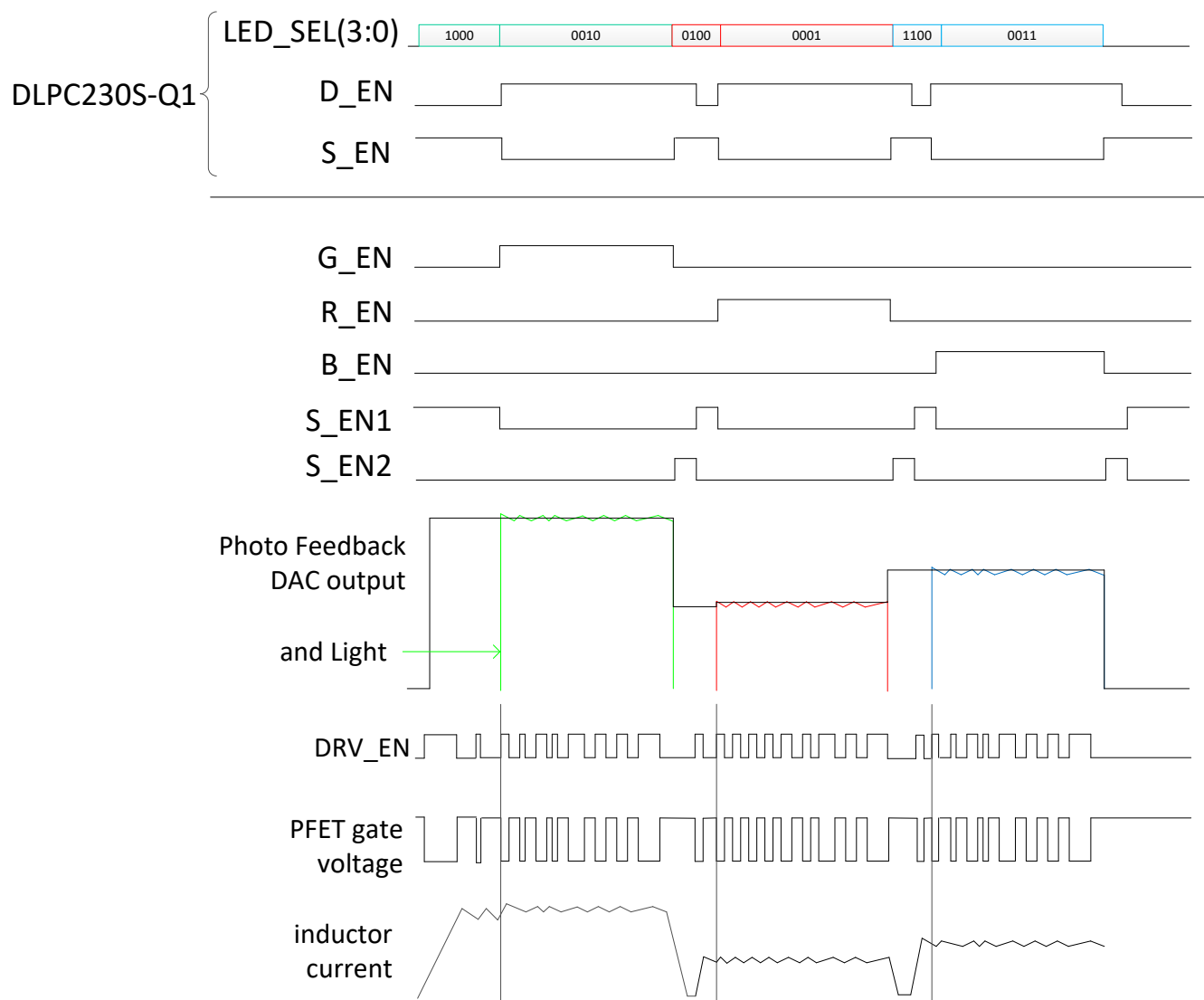

Figure 7-4. Continuous Mode Signal Example

In continuous mode, dimming is accomplished through a combination of amplitude/flux dimming and pulse time attenuation. Amplitude dimming is done by adjusting the photo feedback DAC output and TIA feedback gain. Time attenuation is accomplished by adjusting the length of shunt enable (S_EN from DLPC230S-Q1) and drive enable (D_EN from DLPC230S-Q1) (see Figure 7-5). Figure 7-5 shows an example with a 100% bit and a bit

with time and amplitude attenuation to achieve 32:1 dimming. Figure 7-6 is a more generic example showing how many different dimming levels can be achieved with combinations of time and amplitude dimming.

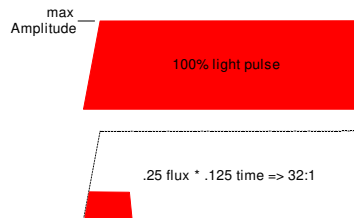

Figure 7-5. Continuous Mode Dimming Illustration 1

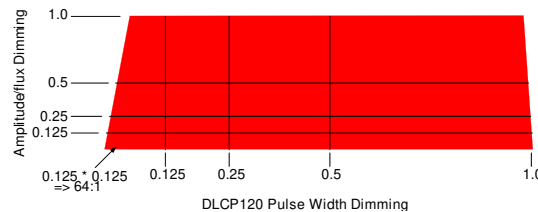

Figure 7-6. Continuous Mode Dimming Illustration 2

7.3.1.3.1 Output Capacitance in Continuous Mode

In continuous mode the CMODE signal from the TPS99000S-Q1 is set low so the FET controlling the *big* (~1 μ F) capacitor is turned off leaving only a small (~ 0.1 μ F) high frequency decoupling capacitance in parallel with the LEDs and shunt FET paths (refer to Figure 7-2). Using a lower capacitance in continuous mode allows the voltage across the capacitor and LED to charge up faster so that the current in the inductor does not overshoot the desired current level before the LED light emission threshold is reached. This prevents the light pulse from overshooting at the beginning of bit slices. (Discontinuous pulse mode requires a larger, ~1 μ F capacitance as will be discussed later in this document. CMODE pin is set high in discontinuous mode to enable higher capacitance in parallel with LEDs).

7.3.1.3.2 Continuous Mode Driver Distortion and Blanking Current

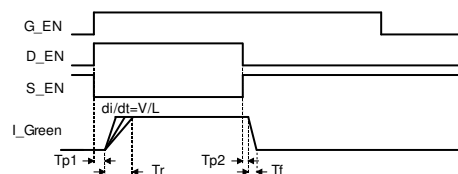

Figure 7-7. First Generation/Legacy System Pulse Distortion Example

As seen in Figure 7-7, the actual LED current pulse is distorted due to the rising (T_r) and falling (T_f) edges rates not being equal, and/or the turn-on (T_{p1}) and turn-off (T_{p2}) propagation delays not being equal. The rising edge turn-on time of the current pulse is primarily a function of the voltage across the inductor and the desired current, plus the inductor current initial condition. This distortion causes both the time attenuation and amplitude attenuation of the pulse to become non-linear functions of the control settings. This can lead to image artifacts.

Blanking time is the period of no light output in between two LED segments. The inductor current during this time is called blanking current. This current is controlled to provide an optimized T_r and T_f .

Blanking current control reduces image artifacts by preventing light overshoot and undershoot.

The blanking current time periods are split into two parts. The first is a dissipation phase where the residual current in the inductor from the previous light pulse is reduced using a dissipative shunt. The second phase is a non-dissipative (low series resistance) shunt phase, where the inductor is charged up to the appropriate current for the next light pulse before current is applied to the LED. This process is illustrated in Figure 7-8.

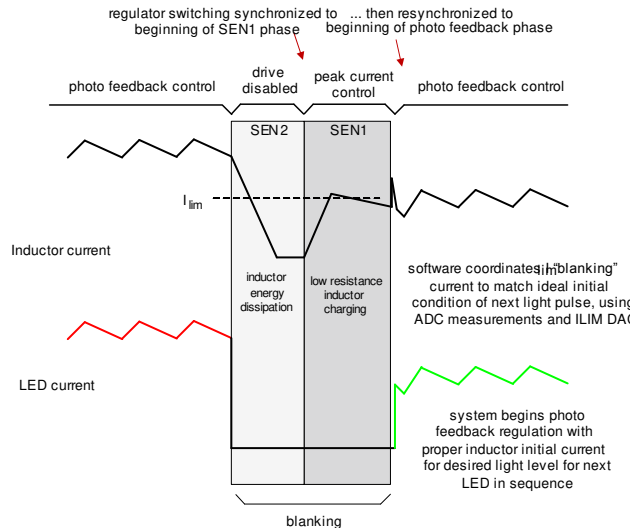

Figure 7-8. Blanking Current Discharge/Charge Cycles

During the first phase of the blanking time, shunt 2 (S_EN2) is enabled while the LEDs are disconnected. This places a load with a higher effective resistance in place of the LEDs. The residual energy in the inductor is dissipated into this load and the inductor current decreases rapidly. Without this feature, a high current in one pulse could cause excessive brightness in the next pulse.

During the second phase of the blanking time, the LED driver charges the inductor through a short circuit shunt (S_EN1). Charging continues until the peak current limit is reached. The peak current limit is set by the ILIM DAC. The peak current limit setting is coordinated by DLPC230S-Q1 software to match the expected operating current during photo feedback operation. (The expected current level is determined from ADC measurements of LED current during prior frames.) When the blanking current time period is over, the S_EN1 short circuit shunt is turned off, the next LED is enabled, the DRV_EN signal is toggled, and the system reverts to photo feedback, hysteretic operation. Because the inductor is pre-charged to the ideal current and the system capacitance is low, light output rising edge is extremely fast, and the transition to stable hysteretic control is nearly immediate. This results in a more rectangular pulse. An illustration of the current paths is shown in [Figure 7-9](#).

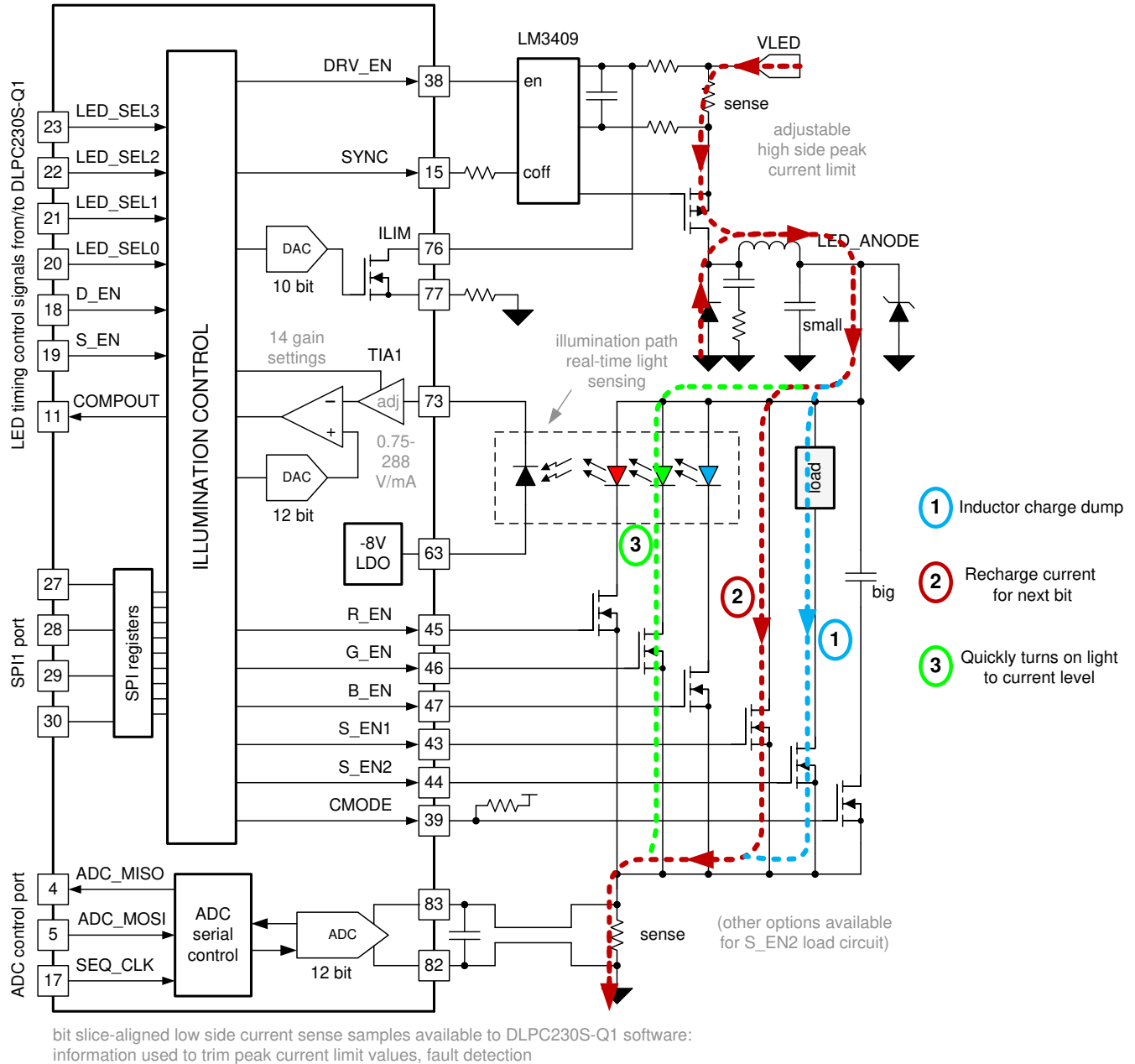

Figure 7-9. Blanking Current Paths

Precise control of the LED pulse shape results in greater dimming range, more display bit depth, and better color and gray ramp accuracy.

7.3.1.3.3 Continuous Mode S_EN2 Dissipative Load Shunt Options

The dissipative shunt, enabled by S_EN2 high, can be implemented with a variety of circuit types.

The circuit type selected for the shunt must be able to discharge the inductor used in the LED drive circuit, as well as protect against over voltage conditions on the LED anode voltage.

The recommended option is to combine the open circuit protection Zener diode with the S_EN2 dissipative shunt functionality, as shown in Figure 7-10. This particular option does not connect the S_EN2 pin but still implements the same functionality as the alternate circuits in Figure 7-9 and Figure 7-11 which do connect the S_EN2 pin.

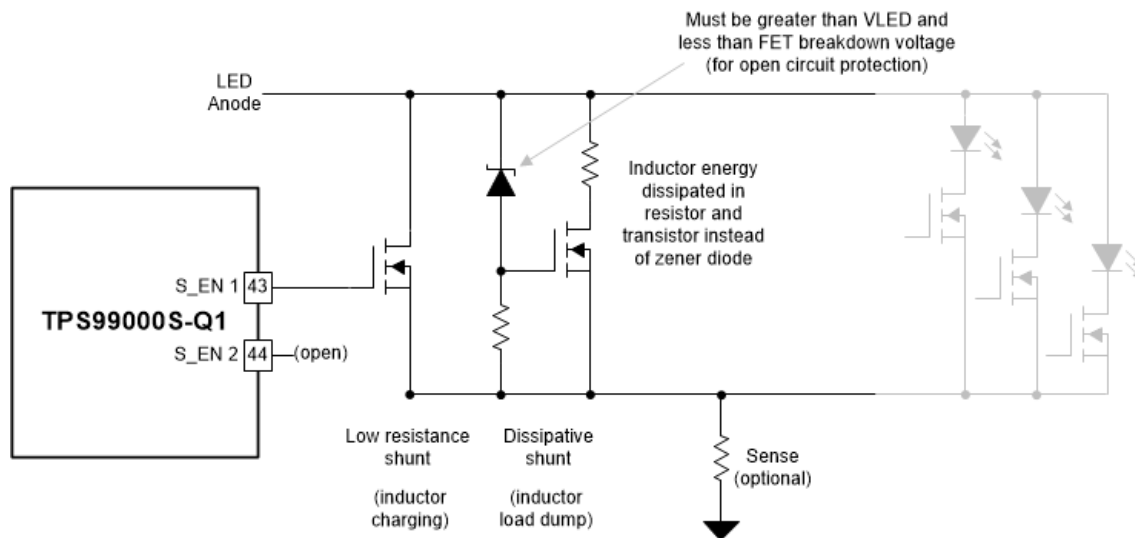

Figure 7-10. Dissipative Shunt / LED Open Circuit Protection Combination 1

In this case, a low power Zener diode is used to turn on a FET when the LED anode voltage exceeds the Zener voltage. The S_EN2 enable is not used in this configuration. Rather, the circuit intentionally is placed in an open circuit condition during the S_EN2 blanking time period. Then the protection circuit turns on and drains energy from the inductor (until the S_EN1 shunt is enabled and the LED anode voltage is reduced). The energy in this case is dissipated in a combination of the load resistor and FET. Care must be taken in selection of the Zener diode and resistor divider to ensure the LED anode voltage does not exceed the RGB select FET breakdown voltage. (An option is to delete the load resistor entirely. Then the dissipation will occur only in the FET, and the LED anode voltage will stay closer to the Zener voltage under all conditions). The Zener voltage must be higher than the worst case voltage of input VLED power rail to avoid unintentional triggering of circuit. And Zener voltage must be below the Vds breakdown voltage of the LED selection FETs.

Alternative circuits with the same functionality can be seen below.

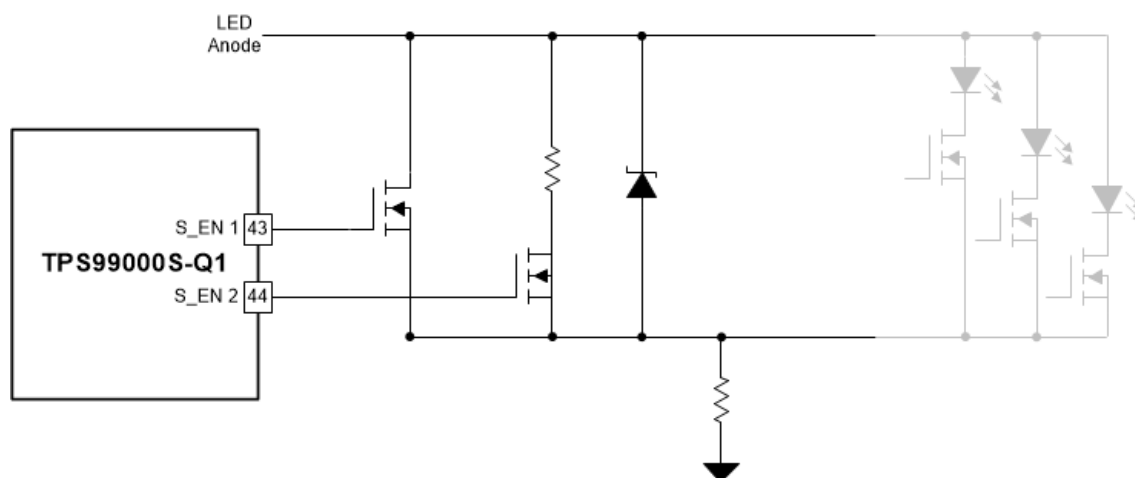

Figure 7-11. Dissipative Shunt / LED Open Circuit Protection Combination 2

In this circuit, the inductor current is discharged through the resistive path controlled by S_EN2.

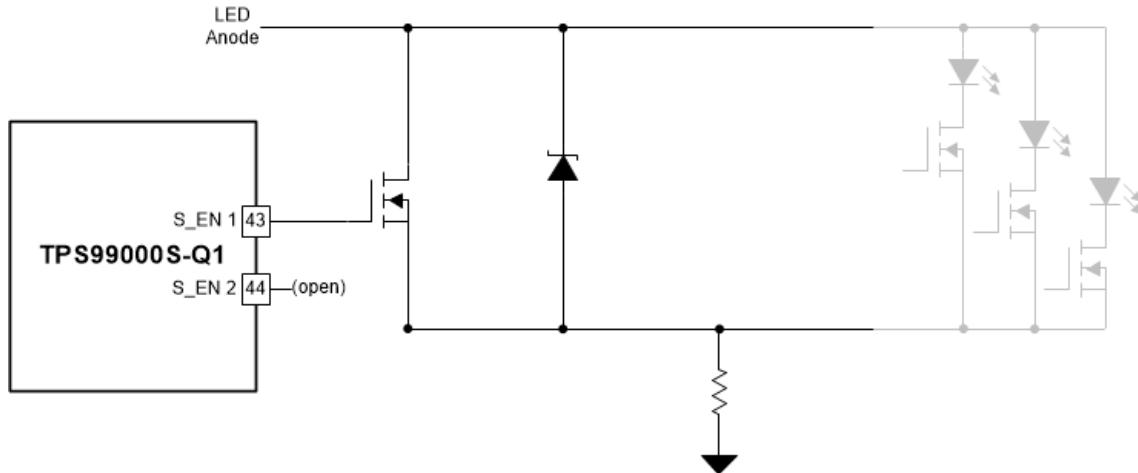

Figure 7-12. Dissipative Shunt / LED Open Circuit Protection Combination 3

In this circuit, the inductor current is discharged through the power Zener diode.

7.3.1.3.4 Continuous Mode Constant OFF Time

A constant off time feature (see COMPOUT_LOW signal in Figure 7-13) is included in continuous mode operation. During continuous mode operation, when the desired light level is achieved, the PFET gate drive is turned off by control of the DRV_EN signal and the light level begins to decrease as the inductor current begins to decrease. In a typical hysteretic controller, when a turn on threshold is reached, the PFET is turned on and the light/inductor current increases again. The frequency of switching is dependent on the difference between the turn on and turn off thresholds, loop delay and discrete component values (with the inductor inductance and voltage being most dominant factors).

In the TPS99000S-Q1, the control is modified to regulate the operating frequency. A *constant off* timer is included in the TPS99000S-Q1 control loop. When the photo feedback comparator threshold is achieved, a counter is started. The length of the counter is adjustable. While this counter is active, the output of the photo feedback comparator is ignored and the PFET drive (via DRV_EN output from TPS99000S-Q1) is disabled. Once the constant off time period counter has expired, the output of the photo feedback comparator is once again used to control the LED current drive. The minimum off-time establishes an upper limit on the hysteretic control loop switching frequency, separate from the natural frequency of the circuit. This feature is useful for assuring the circuit will not operate in the AM radio frequency band, and can also enable the usage of lower inductance value inductors (which can result in system cost savings and power efficiency improvements).

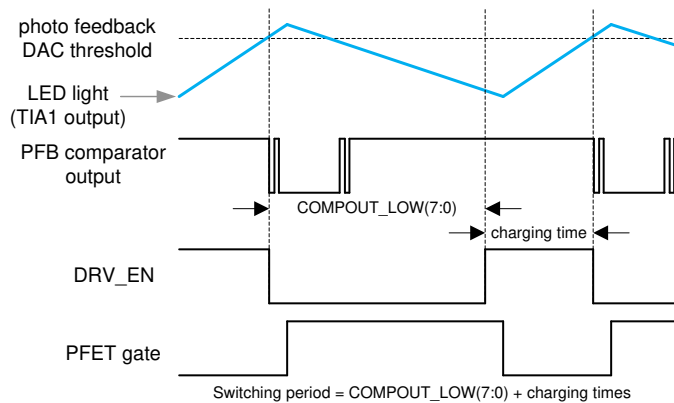

Figure 7-13. COMPOUT_LOW Constant Off Time

7.3.1.3.5 Continuous Mode Current Limit

In continuous mode, a current limit feature prevents damage to LEDs if the requested light output cannot be achieved within LED current specifications. This could happen due to high temperature, or when an LED ages and requires more current to achieve the same brightness. Systems should be designed with sufficient thermal and LED life time margin that this would not happen in practice.

The control scheme utilizes the built in current limit feature of the LM3409 device plus a 10-bit DAC based adjustment feature included in the TPS99000S-Q1. This serves as an alternate limit for the current for the LEDs – inductor drive will be disabled if either the current limit is met or if the photo feedback limit is met, whichever is lower. This peak current limit is configurable on a per LED basis, and is in use during the light-on active periods only. (During blanking periods, this same structure is used to control the blanking current, but different values are loaded onto the ILIM DAC).

The schematic for the current adjustment mechanism is shown in [Figure 7-14](#).

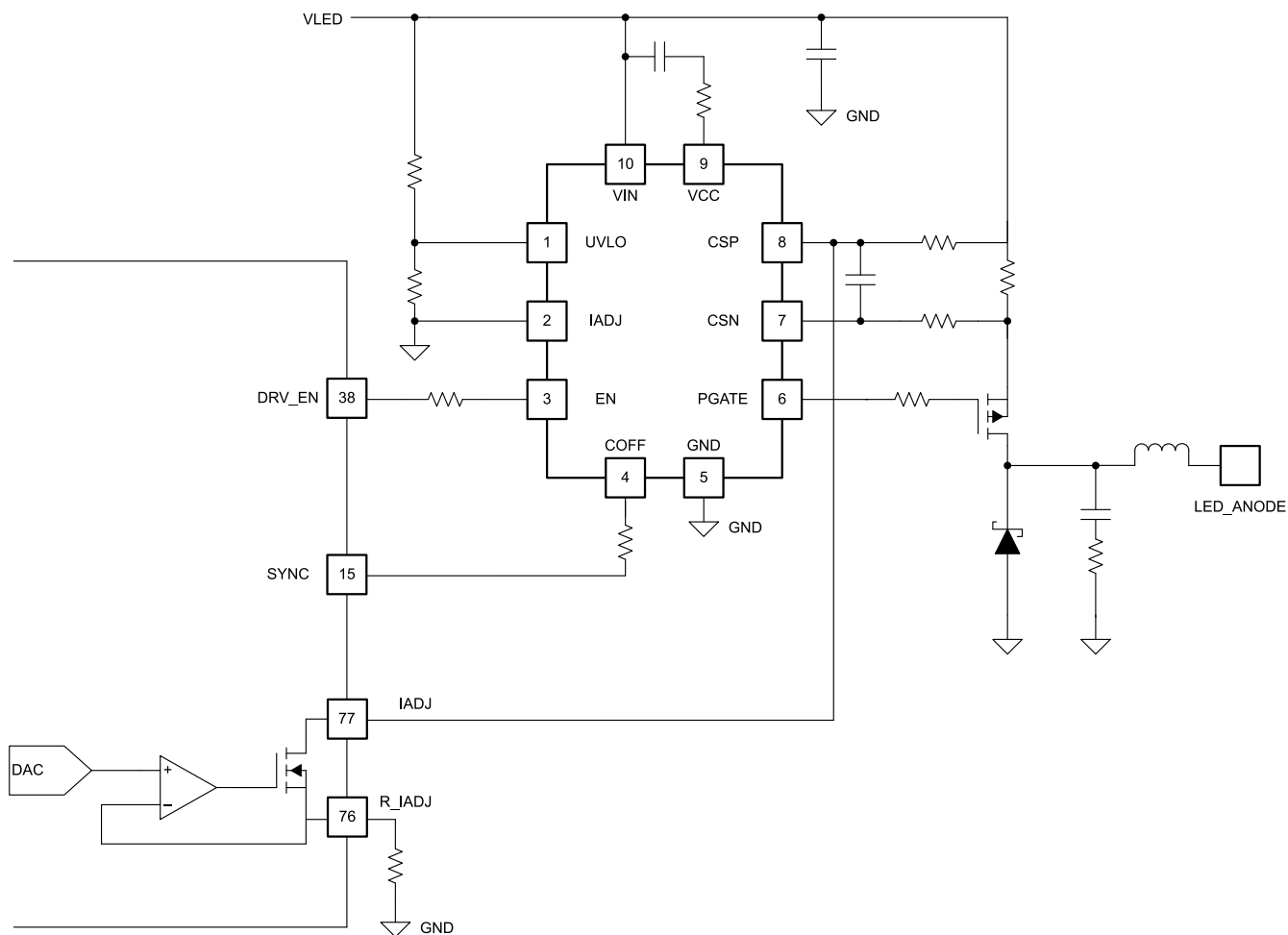

Figure 7-14. IADJ Peak Current Limit Schematic

By design, the LM3409 seeks to create a zero voltage difference between the CSP and CSN pins when IADJ pin is held low and system is operating in peak current limit mode. If the CSP pin voltage is higher than the CSN pin voltage, the PGATE driver is held high (PFET off).

When the ILIM DAC is set to a non-zero voltage, a current is established on the IADJ line of the TPS99000S-Q1 device, which pulls the voltage of the CSP pin downward. If the LM3409 device is enabled and PFET drive not held off by state of the COFF pin, then the current will go up until the voltage across the sense resistor is such that the CSN pin is equal to or greater than the voltage on the CSP pin, at which point the PFET is turned off.

Care must be taken with the routing of the IADJ pin of the TPS99000S-Q1 to insure that it is well isolated from noisy switching nodes, such as the PFET drain node.

7.3.1.4 Discontinuous Mode Operation

Discontinuous mode is used to achieve lower dimming levels. It replaces the constant block of light during a bit slice with a series of light pulses of controlled amplitude, as illustrated in Figure 7-15. The number of pulses is controlled by the DLPC230S-Q1 software.

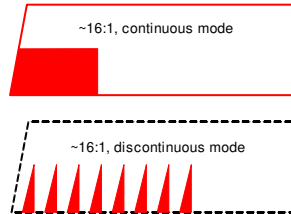

Figure 7-15. Comparison of Continuous and Discontinuous Operation at Equivalent Brightness

Figure 7-15 is an example diagram showing the Discontinuous Mode signals generating 8 pulses which are equivalent in brightness.

In discontinuous mode, the controller produces discrete pulses of light with fixed *off times* between pulses. The amount of light that these pulses produce can be precisely controlled to reach low dimming levels. Two control loops are used to create uniform light pulses:

- Peak current limit loop to create a desired current level in the inductor before it flows through the LED.
- Photo feedback loop to terminate each pulse when the desired light pulse level is achieved.

The initial inductor current and peak light threshold are independently adjustable for each color. See Figure 7-16 and Figure 7-17.

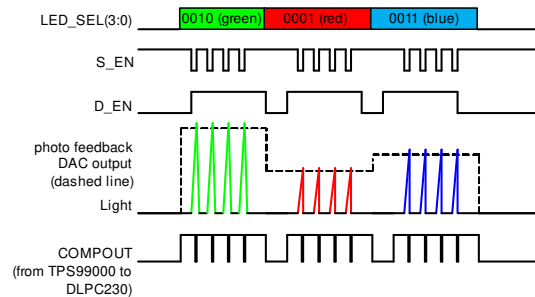

Figure 7-16. Discontinuous Operation DLPC230S-Q1 to TPS99000S-Q1 Signals

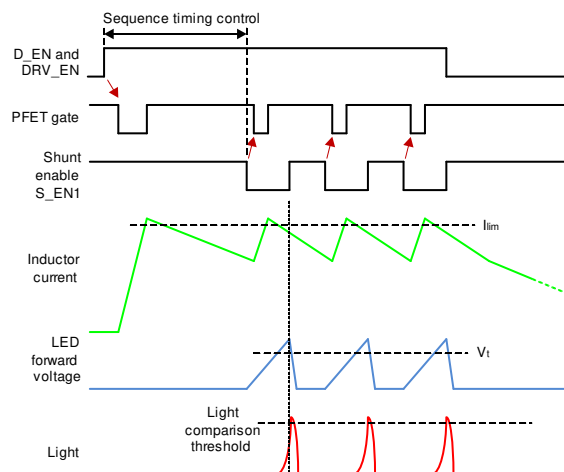

Figure 7-17. Discontinuous Mode Operation Inductor Current/LED Voltage

Discontinuous mode consists of a series of triangular pulses of light. The DLPC230S-Q1 is in charge of requesting and counting the total number of pulses. A bit slice begins with the low resistance shunt enable (S_EN1) on, and with an RGB color selected. Then DLPC230S-Q1 asserts D_EN. This causes the TPS99000S-Q1 to turn on the LED current drive (DRV_EN) and the system charges the inductor into the low resistance shunt until the peak current limit (as programmed with ILIM DAC) is reached. Then after a programmable amount of time the DLPC230S-Q1 drives S_EN low, forcing inductor current to flow through the selected LED.

The TPS99000S-Q1 detects the falling edge of S_EN from the DLPC230S-Q1 and issues an on/off/on toggle of the DRV_EN signal. This allows current to flow through the inductor and increases the voltage at the LED anode. When the LED forward voltage is achieved, it begins to emit light. Once the photo feedback loop (TIA, photo feedback comparator, photo feedback DAC) senses the desired light threshold has been crossed, the S_EN1 signal is re-asserted high, and the light pulse is terminated.

The COMPOUT signal going low indicates to the DLPC230S-Q1 that the pulse has been completed. The DLPC230S-Q1 immediately sets S_EN output high (which sets TPS99000S-Q1 output S_EN1 high), then waits for a programmable length of time. After that period of time, the DLPC230S-Q1 will decide either to drive D_EN low and wait for the next bit slice or issue a request for a new pulse by placing the S_EN output low. When S_EN output is placed low, the TPS99000S-Q1 places S_EN1 low (forcing current through LED) and toggles DRV_EN to request a new peak limit current pulse cycle. This process repeats until the correct number of pulses for the given bit slice have been completed.

In very low brightness operation, the TPS99000S-Q1 SYNC (LM3409 COFF) timer is disabled. As a result, DRV_EN is only toggled at the beginning of each light pulse. This synchronizes the inductor and LED current. This synchronization keeps LED pulse heights very consistent from one video frame to the next, preventing flicker.

7.3.1.4.1 Discontinuous Mode Pulse Width Limit

The TPS99000S-Q1 has a feature which limits the time duration of each discontinuous mode pulse. A count monitors the length of time current is applied to the LED during a pulse event and compares time to a programmable time limit. If the time limit expires before the light output threshold is reached, the discontinuous pulse is terminated. The pulses in both cases (photo level or time limit expiration) are terminated by enabling the S_EN1 low resistance shunt. This limits maximum brightness in the event photo feedback threshold is not reached. Independent RGB values for the discontinuous pulse width limit are supported. This process is illustrated in [Figure 7-18](#).

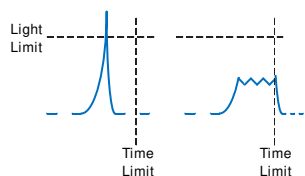

Figure 7-18. Discontinuous Mode Pulse Width Time Limit

7.3.1.4.2 COMPOUT_LOW Timer in Discontinuous Operation

In discontinuous operation, the same COMPOUT_LOW parameter that sets the switching frequency for the continuous mode case serves as a noise filter for discontinuous operation. The circuit triggers on the first falling edge of the photo threshold comparator, which equates to the end of a pulse. Then all subsequent rising and falling edges of the comparator output are ignored for a pre-defined amount of time, providing a glitch suppression filter function for discontinuous operation, and controlling the timing between pulses.

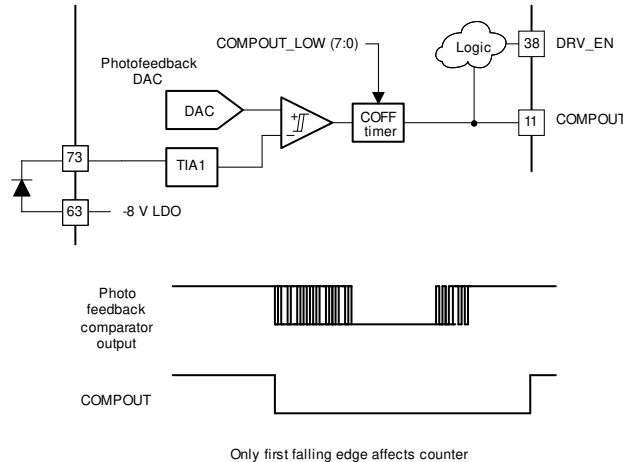

Figure 7-19. COMPOUT_LOW Timer as Glitch Filter in Discontinuous Operation

7.3.1.4.3 Dimming Within Discontinuous Operation Range

When operating in discontinuous mode, two methods of dimming are used concurrently to reduce brightness of the display:

1. Amplitude dimming using the photo feedback DAC settings.
2. Controlling the number of pulses per bit slice (via commands to DLPC230S-Q1, selecting specific lookup table data).

Figure 7-20 is an example of the brightest LUT data table having 8 pulses per LSB (smallest bit slice). The LED pulse height is modulated to achieve a 2:1 dimming ratio while still maintaining 8 pulses per LSB. To allow for a seamless transition to lower dimming levels, a change to 4 pulses per LSB plus higher LED amplitude is made as illustrated in Figure 7-21. The total light generated in both cases in Figure 7-21 is approximately equal. A system calibration is used to determine this $\frac{1}{2}$ LED amplitude photo feedback DAC setting.

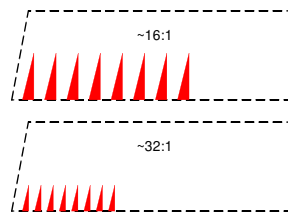

Figure 7-20. 2:1 Dimming Within a Sequence

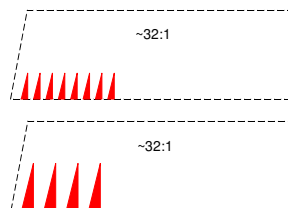

Figure 7-21. Discontinuous Operation Pulse Count Change

As a smooth dimming (brightness going down) sequence continues, the process above eventually results in using a 1 pulse per LSB. Amplitude dimming is used to dim to the absolute minimum display brightness level as illustrated in Figure 7-22.

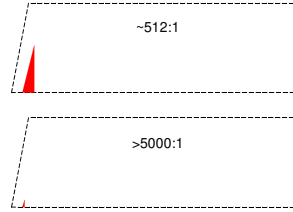

Figure 7-22. Discontinuous Dimming with One Pulse Per LSB Sequence

As shown in [Figure 7-22](#), once a single pulse-per-LSB is selected, all remaining dimming must occur using only pulse height threshold reduction.

7.3.1.4.4 Multiple Pulse Heights to Increase Bit Depth

With the TPS99000S-Q1, up to four sets of photo feedback threshold settings are supported within a given sequence. This is useful in discontinuous operation to create smaller sub-LSB bits (bits that are smaller than the normal LSB).

The LED_SEL(3:0) lines are encoded to include *group* information as well as color selection (and blanking current selection).

Each group can be defined to determine different behavior for specific color bits. For example, Group 0 can be used for LSB, and Group 1 can be used to create LSB-1.

Table 7-1. LED Selection Table

LED_SEL(3:0)	NAME	ACTION
"0000"	OFF	Driver Disabled Mode S_EN1 forced high RGB selects low
"0100"	R BLANKING	LED_SEL(1:0) - "00"=blanking
"1000"	G BLANKING	LED_SEL(3:2): "01"=red
"1100"	B BLANKING	"10"=green "11"=blue
"0001"	GRP0 RED	Driver Enabled Mode: LED_SEL(3:2) - Define Group: '00' - Group 0 '01' - Group 1 '10' - Group 2 '11' - Group 3 LED_SEL(1:0): "01" - red "10" - green "11" - blue
"0010"	GRP0 GREEN	
"0011"	GRP0 BLUE	
"0101"	GRP1 RED	
"0110"	GRP1 GREEN	
"0111"	GRP1 BLUE	
"1001"	GRP2 RED	
"1010"	GRP2 GREEN	
"1011"	GRP2 BLUE	
"1101"	GRP3 RED	
"1110"	GRP3 GREEN	
"1111"	GRP3 BLUE	

The group1-3 RGB selections may be used to create fractional LSBs in the sequence, as illustrated in [Figure 7-23](#).

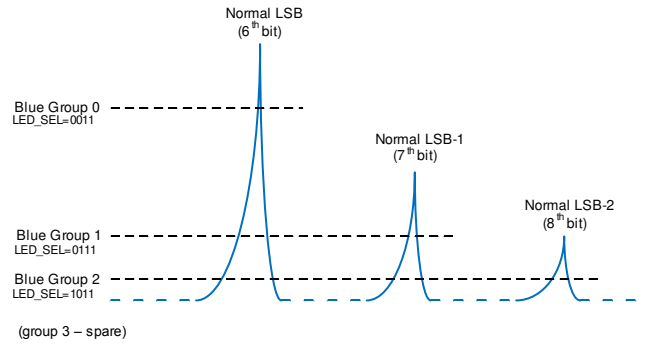

Figure 7-23. Extended LSB Bit Depth in Discontinuous Operation

This feature, combined with ability to make smaller absolute size light pulses, provides a method to extend the practical bit depth limit from the typical 6 bits per color, as is the case in legacy systems, to 7 or 8 bits with TPS99000S-Q1/DLPC230S-Q1 second generation systems.

7.3.1.4.5 TIA Gain Adjustment

The gain of TIA1 can be adjusted to achieve a larger dimming range. Increasing the TIA gain reduces the light output for a given photo feedback DAC level. A higher gain reduces the brightness range achievable but increases the resolution within the desired range.

7.3.1.4.6 Current Limit in Discontinuous Mode

The current limit determines the maximum current allowed through the inductor. A higher current limit enables higher pulse heights to be achieved. A lower current limit creates a slower rising edge on each pulse and reduces the overshoot of the pulse. Therefore, at lower dimming levels the current limit is reduced.

7.3.1.4.7 CMODE *Big Cap* Mode in Discontinuous Operation

The TPS99000S-Q1 provides an output signal, CMODE, that can be used to drive the gate of a FET that switches in a larger capacitor for discontinuous operation. High capacitance mode is only used during discontinuous operation. (High capacitance causes issues in continuous operation, minimizing capacitance is preferred for that mode). The higher capacitance slows the rate at which the forward voltage of the LED increases during the pulse creation process. The slower charge rate causes the transition from no light emission to full light emission to extend in time. In selecting the proper capacitance, a balance between good edge rate control and total time for pulse to reach threshold must be made. Attention should be paid to the temperature characteristics of this capacitor. Less variation of capacitance over temperature will result in more accurate, repeatable results in cold/hot conditions.

Benefits:

- Pulse stability
- Support for lower light output thresholds, due to slower pulse edge rates

The charge and discharge loops using the CMODE *big cap* are as follows:

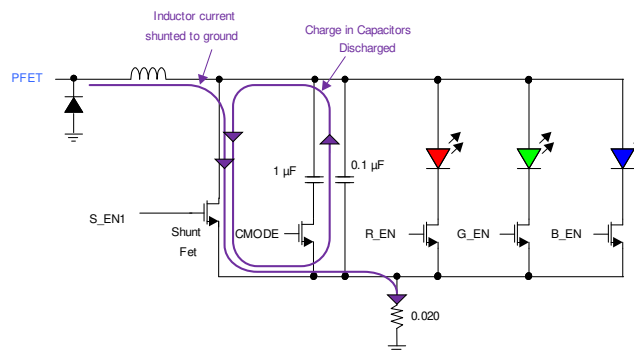

Figure 7-24. Discontinuous Mode Current Paths with Shunt Enabled

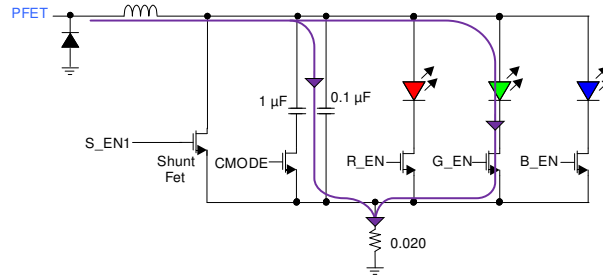

Figure 7-25. Discontinuous Mode Current Paths with Shunt Disabled

7.3.2 Over-Brightness Detection

The TPS99000S-Q1 has two methods for detecting over-brightness conditions. The first method uses a combination of ADC measurements and photo feedback comparator output to detect breaks in the photo feedback loop. Another method uses a secondary photodiode to detect over-brightness in the HUD image.

7.3.2.1 Photo Feedback Monitor BIST

A disconnection of the primary photodiode breaks the feedback loop used to regulate LED output. Any disconnection of this photodiode should be detected so that the LEDs can be disabled.

The DLPC230S-Q1 software and the TPS99000S-Q1 implement a photo feedback monitor Built-In Self-Test (BIST) to detect a disconnected photodiode. Every video frame, the DLPC230S-Q1 software uses ADC measurements of the LED current and TIA output, and COMPOUT falling edges to detect a disconnected photodiode.

In continuous mode, the DLPC230S-Q1 software determines that the photodiode is disconnected if all the LED currents are at maximum, but the TIA measurements are at a minimum. This indicates that the LEDs are conducting current, but the photodiode is not responding to light output from the LEDs.

In discontinuous mode, COMPOUT edges are used to detect a photodiode disconnect. A falling edge on COMPOUT indicates that an LED pulse has reached the desired threshold. This is only possible if the photodiode is connected. Therefore, the COMPOUT edges are detected by the DLPC230S-Q1 software to determine if the photodiode is connected.

7.3.2.2 Excessive Brightness BIST

The excessive brightness BIST uses a secondary photodiode connected to TIA2 to detect over-brightness conditions in the output image of the HUD.

The output of TIA2 is compared to a programmable threshold. If the output exceeds the threshold, the DLPC230S-Q1 software will log an error. TIA2 can be used in a high bandwidth or low bandwidth configuration for this BIST.

The low bandwidth mode provides an RC filter low-passed value of the TIA2 output. The resistor element of the filter is embedded in the TPS99000S-Q1, while the capacitor is an external component. If the low bandwidth input is used, the value of the capacitor should be expected such that the time constant is longer than the frame time.

The hardware controls for the threshold are not synchronized to the dimming functionality of the TPS99000S-Q1. Therefore, this feature may need to be enabled or disabled, or the thresholds may need to be adjusted based on the dimming level of the HUD.

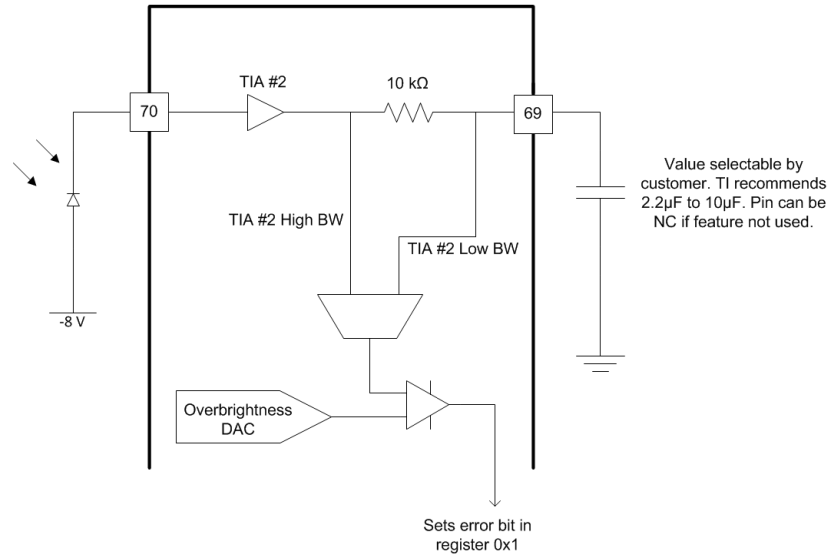

Figure 7-26. Excessive Brightness Detection Circuit

7.3.3 Analog to Digital Converter

The TPS99000S-Q1 includes a 12-bit analog to digital converter block with a 32:1 input mux and dual sample-and-hold circuits. It also includes a custom high speed serial control interface which when used in tandem with the DLPC230S-Q1 provides up to 63 DMD sequence-aligned samples per frame, with hardware-based sample timing and shadow-latched results. The hardware sample timing and shadow latch relieves the DLPC230S-Q1 processor from ADC timing tasks, freeing up processor resources for other uses.

[Figure 7-27](#) illustrates the structure of the ADC controller blocks in the two ASICs.

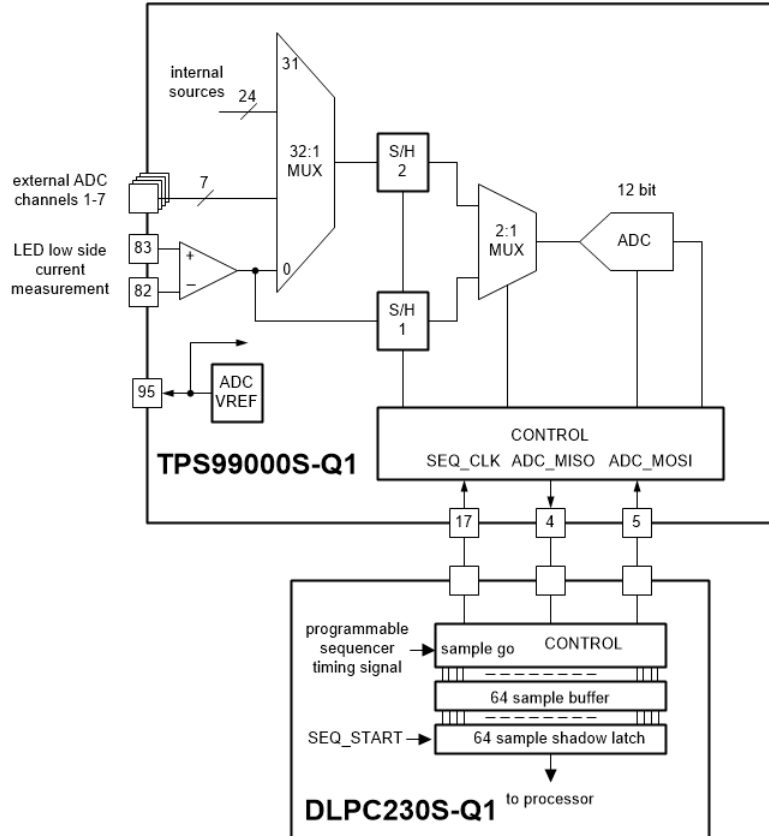

Figure 7-27. ADC Subsystem Block Diagram

The ADC block contains a dedicated channel reserved for differential low side LED current measurements. Two sample-and-hold circuits are included to support paired LED current/voltage measurements. (Note: when performing paired samples, they are sampled simultaneously, but converted sequentially, so the conversion time doubles). An additional seven external ADC channels are supported. The remaining 24 multiplexer inputs enable measurement of internal TPS99000S-Q1 operating parameters.

The DLPC230S-Q1 contains a custom ADC control block that supports up to 63 ADC samples per frame. The samples are aligned with DMD sequencer activity, configurable through system configuration tools. This alignment makes measurement of specific light pulses (LED current, voltage, and TIA output) within a sequence possible, with precise repeatability from frame to frame. Up to 63 samples per frame are supported. The 63 sample buffer includes a shadow latch that updates each frame. This latched output is held constant for a complete frame time, allowing time for the DLPC230S-Q1 to collect and process the information.

A reference voltage output is also included in the ADC block. This provides a low current voltage reference which matches the reference used by the ADC for conversion. This external reference can be used to bias thermistor voltage dividers, providing greater accuracy than would be possible using a mix of external and internal references. (**Note:** Current supply is limited. Loads which exceed the specified current maximum rating on ADC_VREF output may result in unpredictable ADC behavior). Regardless of whether the reference voltage is used, a 0.1uF capacitor should be connected from this pin to ground.

7.3.3.1 Analog to Digital Converter Input Table

Table 7-2. Analog to Digital Converter Input Table

PARAMETER		INTERNAL OR EXTERNAL	TEST CONDITIONS ⁽¹⁾	MIN	TYP	MAX	UNIT
Channel 0, Gain	Low side sense amp	External	Gain set to 24x	22.56	24	25.44	V/V
Channel 0, Gain	Low side sense amp	External	Gain set to 12x	11.28	12	12.72	V/V
Channel 0, Gain	Low side sense amp	External	Gain set to 9x	8.46	9	9.54	V/V
Channel 1, Gain	ADC_IN1_PAD (LED_ANODE)	External		0.980	1.000	1.020	V/V
Channel 2, Gain	ADC_IN2_PAD (VLED)	External		0.980	1.000	1.020	V/V
Channel 3, Gain	ADC_IN3_PAD	External		0.980	1.000	1.020	V/V
Channel 4, Gain	ADC_IN4_PAD	External		0.980	1.000	1.020	V/V
Channel 5, Gain	ADC_IN5_PAD (R_LED_THERM)	External		0.980	1.000	1.020	V/V
Channel 6, Gain	ADC_IN6_PAD (G_LED_THERM)	External		0.980	1.000	1.020	V/V
Channel 7, Gain	ADC_IN7_PAD (B_LED_THERM)	External		0.980	1.000	1.020	V/V
Channel 8, Gain	VBIAS	Internal		0.0596	0.0621	0.0646	V/V
Channel 9, Gain	VOFFSET	Internal		0.1112	0.117	0.1218	V/V
Channel 10, Gain	VRESET	Internal		-0.1978	-0.190	-0.1822	V/V
Channel 10, Offset	VRESET	Internal		-1.217	-1.1935	-1.169	V
Channel 11, Gain	VMAIN	Internal		0.52546	0.559	0.59254	V/V
Channel 12, Gain	DVDD	Internal		0.31302	0.333	0.35298	V/V
Channel 13, Gain	V1.1	Internal		0.65706	0.699	0.74094	V/V
Channel 14, Gain	V1.8	Internal		0.40326	0.429	0.45474	V/V
Channel 15, Gain	V3.3	Internal		0.2209	0.235	0.2491	V/V
Channel 16, Offset	M8 LDO offset	Internal		8.15	8.400	8.65	V
Channel 16, Gain	M8 LDO	Internal		0.980	1.000	1.020	V/V
Channel 17, Gain	ext ADC VREF	Internal		0.49	0.5	0.51	V/V
Channel 18, Gain	Driver Power	Internal		0.20398	0.217	0.23002	V/V
Channel 19, Gain	Die Temp1	Internal		0.490	0.500	0.510	V/V
Channel 20, Gain	Die Temp2	Internal		0.490	0.500	0.510	V/V
Channel 21, Gain	ILED Control DAC	Internal		0.490	0.500	0.510	V/V
Channel 22, Gain	Photo Feedback Control DAC	Internal		0.490	0.500	0.510	V/V
Channel 23, Gain	Over-Brightness Control DAC	Internal		0.490	0.500	0.510	V/V
Channel 24, Gain	TIA1 Real Time	Internal		0.490	0.500	0.510	V/V
Channel 25, Gain	TIA1 Low Bandwidth	Internal		0.490	0.500	0.510	V/V
Channel 26, Gain	TIA2 Real Time	Internal		0.490	0.500	0.510	V/V
Channel 27, Gain	TIA2 Low Bandwidth	Internal		0.490	0.500	0.510	V/V
Channel 28, Gain	Channel not used	Internal					
Channel 29, Gain	Main Bandgap, 0.5 V	Internal		0.980	1.000	1.020	V/V
Channel 30, Gain	TIA1 Monitor	Internal		0.980	1.000	1.020	V/V
Channel 31, Gain	TIA2 Monitor	Internal		0.980	1.000	1.020	V/V

(1) Conversion formula is $(X + \text{Offset}) * \text{Gain}$. X is the input voltage. Offset is 0 V unless specified above.

7.3.4 Power Sequencing and Monitoring

The TPS99000S-Q1 is specifically designed to perform correct power-up and power-down sequencing to ensure long term reliable operation of the DMD. The high voltage DMD mirror supplies require special power sequencing order, and restrictions on voltage differences between the power rails (VRESET, VBIAS, and VOFFSET) throughout power up, power down, and normal operation. The TPS99000S-Q1 handles these requirements for the system designer.

7.3.4.1 Power Monitoring

Main asynchronous digital logic reset (DVDD_RSTZ) – Monitor of the main power of the 3.3 V power supply input to the TPS99000S-Q1 . This monitor output is used as an asynchronous reset for all of the digital logic inside TPS99000S-Q1 .

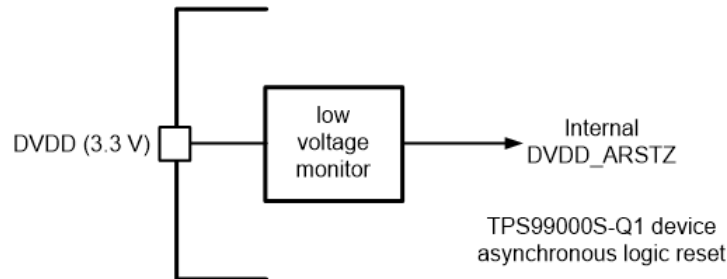

Figure 7-28. Internal DVDD Monitor

The PROJ_ON pin is the main on/off switch for DLP subsystem. 1 is ON, 0 is OFF. Once DVDD_ARSTZ is released, TPS99000S-Q1 will begin sampling the PROJ_ON pin. If it is low, system stays in the OFF state. If it goes high, TPS99000S-Q1 begins to progress through the power-on process.

The TPS99000S-Q1 includes a VMAIN *brown out* monitor function. A voltage monitor observes the voltage on the VMAIN input pin, as shown in Figure 7-29. The Zener may be necessary for over voltage protection of the pin, in case the voltage being monitored has the potential to go high, such as a battery input.

Either PROJ_ON or VMAIN may be used to turn the system on and off, and doing so will remove power to the DLPC230S-Q1. For fast control of turning the display on and off without removing power to the DLPC230S-Q1, change the operating mode of the DLPC230S-Q1 embedded software between 'Standby' and 'Display'.

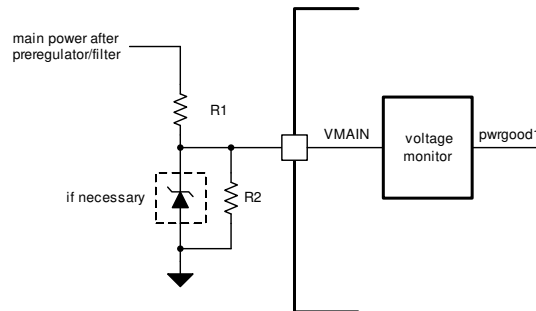

Figure 7-29. VMAIN Brown Out Monitor

This monitor is used to provide the DLP subsystem with an early warning that power to the unit is going away. The system will park the DMD mirrors and proceed to a ready for power-off state if the VMAIN input voltage falls below a fixed threshold. External resistors should be used to divide the input power rail. Once a VMAIN brown out occurs, the main power rails to the TPS99000S-Q1 must remain within their operating ranges until the TPS99000S-Q1 power-down is complete.

The main power rails to the chipset (6 V, 3.3 V, 1.8 V and 1.1 V) are monitored with real time power monitors as well. Each of these monitors is logically 'OR'ed together to produce the *pwrgood2* signal in Figure 7-30.

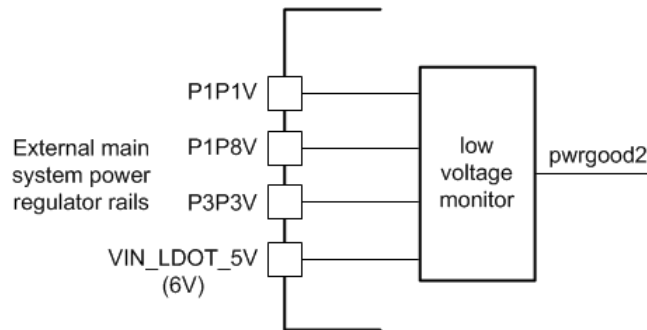

Figure 7-30. Real-Time Power Rail Monitors

Additionally, all power within the TPS99000S-Q1 can be monitored by the ADC function. DLPC230S-Q1 software configures the ADC block to collect all voltage information in the system each frame. Any gross out of specification issues are captured and reported as system errors in the DLPC230S-Q1 system status.

7.3.5 DMD Mirror Voltage Regulator

The DMD mirror voltage regulator generates three high voltage supply rails: DMD_VRESET, DMD_VBIAS and DMD_VOFFSET. The DMD regulator uses a switching regulator where the inductor is time shared between all three supplies. The inductor is charged up to a certain current level and then discharged into one of the three supplies. In cases where a supply does not need additional charge, the time slot normally allocated to that supply is skipped and the supplies requiring more charge receive all of the charging time.

For proper operation, specific bulk capacitance values are required for each supply rail. Refer to [Section 6.11](#) for recommended values for the capacitors. The regulator contains active power down/discharge circuits. To meet timing requirements, total capacitance (actual capacitance, not the nominal) must not exceed these levels by substantial amounts, as defined in [Section 6.11](#). Power down timing should be verified in each specific system design. Too low of a total capacitance will result in excessive ripple on the supply rails which may impact DMD mirror dynamic behavior. Care should be taken to use capacitors which maintain the recommended minimum capacitance over the expected operating device temperature range. Large size packages are required here that do not lose so much capacitance at high voltages.

Although the average current drawn by the DMD on these supplies is small (10's of mA worst case), the peak currents can be several amps over 10's of nano-seconds. To supply this peak current, use of small value, high frequency decoupling capacitors should be included as close as practical to the DMD power input pins.

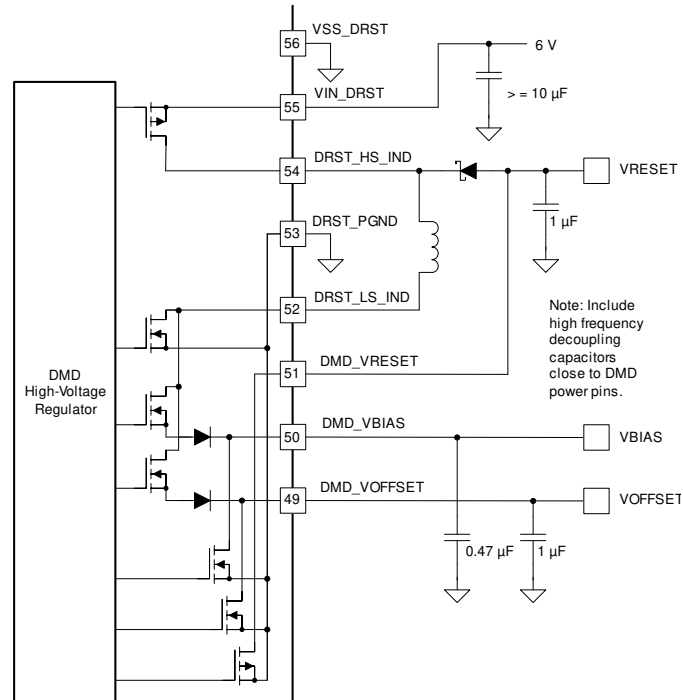

Figure 7-31. DMD Voltage Regulator Circuit

7.3.6 Low Dropout Regulators

The TPS99000S-Q1 includes four low drop out regulators, dedicated to specific internal functions:

- A fixed -8 V negative regulator for photodiode reverse biasing (VIN_LDOT_M8 input, VLDOT_M8 output)
- A 5 V output regulator for internal analog circuits (VIN_LDOT_5V input, VLDOT_5V output)
- A 3.3 V output regulator for internal analog (VIN_LDOT_3P3V input, VLDOT_3P3V output)
- A 3.3 V output regulator dedicated to the ADC block (VIN_LDOA_3P3 input, VLDOA_3P3 output)

The positive output LDO regulators are all designed to operate from the same nominal 6 V input as is needed by the LED selection FET gate driver supply input, DRVR_PWR and the DMD mirror voltage regulator, VIN_DRST. However, care must be taken to isolate the sensitive analog circuit power supply inputs from switching noise, through dedicated sub-planes and supply filtering techniques. Noise on the analog supply rails will directly impact system dimming range performance, limiting stable operation at low brightness levels.

The negative 8 V LDO is designed to use the DMD_VRESET power rail as its power source. (Note that this usage implies that the TIA/photodiode path will not be available for use until the DMD is in a powered up state.)

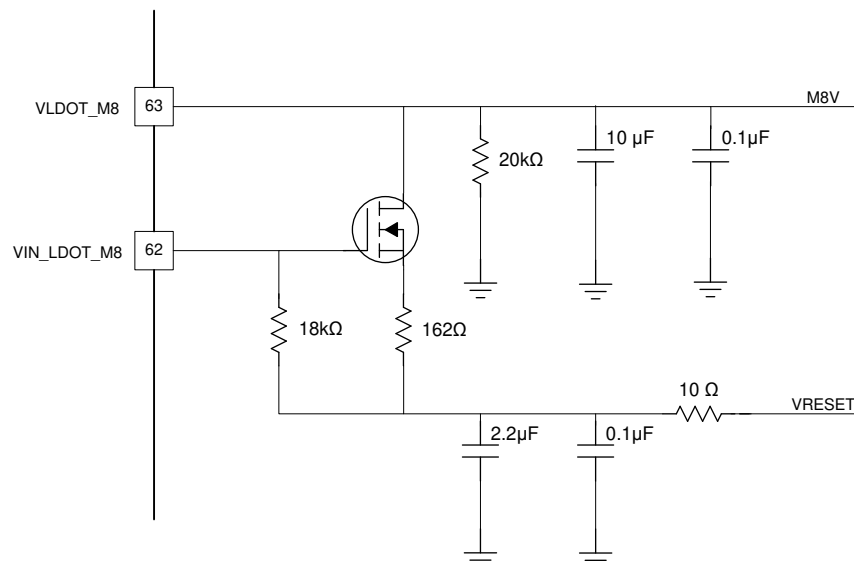

Figure 7-32. Negative 8 V LDO Circuit

CAUTION

Applications that do not use a photodiode do not require the -8 V regulator. VLDOT_M8 and VIN_LD0T_M8 may be left disconnected if the option in the DLPC230 SW to prevent enabling of the -8 V LDO is selected. If these pins are not connected, care must be taken to confirm that the -8 V LDO is not enabled. If this regulator is enabled while the pins are disconnected, permanent damage may be caused to the device.

7.3.7 System Monitoring Features

7.3.7.1 Windowed Watchdog Circuits

The TPS99000S-Q1 contains two windowed watchdog circuits that can be used to detect malfunctions within the DLPC230S-Q1.

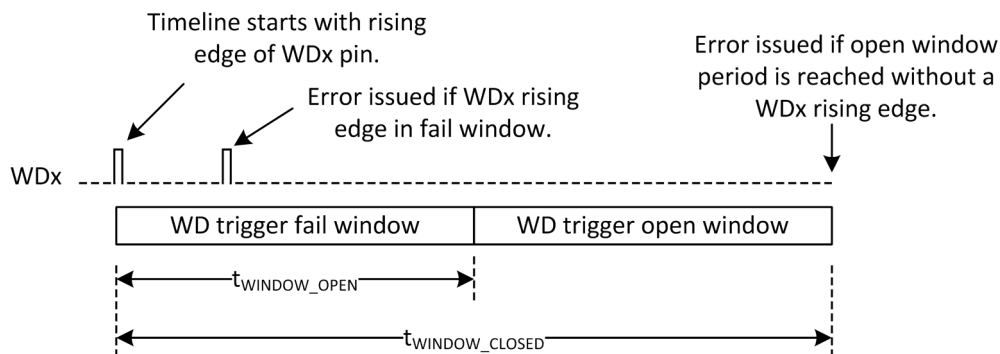

Figure 7-33. Windowed Watchdog Function

The DLPC230S-Q1 software uses both watchdog circuits. Watchdog #1 (WD1) monitors the internal microprocessor of the DLPC230S-Q1 through a wire connection to a dedicated GPIO line from DLPC230S-Q1. Watchdog #2 (WD2) is used to monitor the DLPC230S-Q1 sequencer operation (through monitoring of the SEQ_START pin, wired to WD2 input).

When this function is enabled, two registers control the timing of the opening and closing of a watchdog trigger window. Process is initiated by a rising edge on the respective WDX pin. If another rising edge occurs before the WD trigger window opens, a watchdog error is issued. If the end of the open window period is reached without

receiving a rising edge on WDX, an error is issued. The process restarts any time a WDX rising edge is received. The two watchdogs are independent.

7.3.7.2 Die Temperature Monitors

The TPS99000S-Q1 contains two on-chip die temperature monitors, for redundancy purposes, to monitor the internal temperature of the TPS99000S-Q1. Each monitor has an output that indicates whether the die temperature has exceeded one of two thresholds. One monitors a warning threshold, and the other monitors an over-temperature error threshold. If the warning threshold is exceeded, a processor interrupt may be generated. If the over-temperature error threshold is exceeded during operation, the TPS99000S-Q1 will initiate an emergency shutdown procedure and then wait for a toggle of the PROJ_ON pin to initiate a system restart while operating in a low power state. The system will not proceed through the power on initialization steps unless the on die temperature is below the warning threshold. The status of these temperature monitor output bits is available over the SPI buses as long as DVDD and VDD_IO power supplies are up and stable.

7.3.7.3 External Clock Ratio Monitor

The TPS99000S-Q1 operates from two primary clock sources: an internal low frequency oscillator (2 MHz, used for system initialization and other maintenance purposes), and an external high speed (30 MHz) clock, SEQ_CLK, used for most timing critical applications, such as the logic inside the illumination control block and ADC. The TPS99000S-Q1 includes a function that reports the ratio of this internal vs. external clock. This ratio is available over the SPI bus. The DLPC230S-Q1 can check this ratio and compare to expected value. If the ratio is incorrect, there is a possibility the DLPC230S-Q1 oscillator may have locked to an incorrect harmonic, or some other fault condition has occurred.

7.3.8 Communication Ports

7.3.8.1 Serial Peripheral Interface (SPI)

The TPS99000S-Q1 provides two four-wire SPI ports that support transfers up to 30 MHz clock rates. The primary port (SPI1) supports register reads and writes, and serves as the primary set up and control interface for the device. The DLPC230S-Q1 is the master of SPI1 to control the TPS99000S-Q1 during system operation. A secondary read-only four wire SPI port (SPI2) is available to provide status information to an optional second microcontroller in the system.

For both ports, the SPIx_SS_Z serves as the active low chip select for the SPI port. A SPI frame is initiated by SPIx_SS_Z pin going low, and is completed when SPIx_SS_Z pin is driven high.

The secondary SPI port serves as a read-only system monitor port. All registers in the address space are read accessible over this port. The protocol is effectively the same as the main port except for being read-only. Note that data is clocked in on the rising edge of the SPI2_CLK.

When using this port, one must always transmit the full transaction packet. Failure to do so may result in corruption of data.

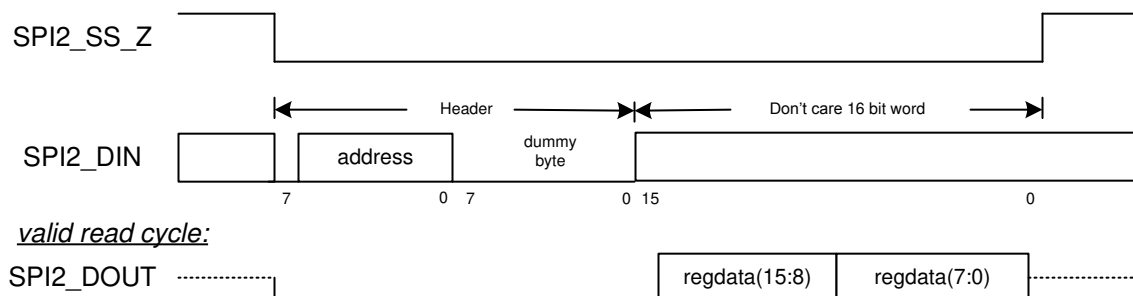

Figure 7-34. SPI Port 2 Protocol (Read Only)

7.4 Device Functional Modes

The following diagram in [Figure 7-35](#) illustrates the functional operating modes of the TPS99000S-Q1 .

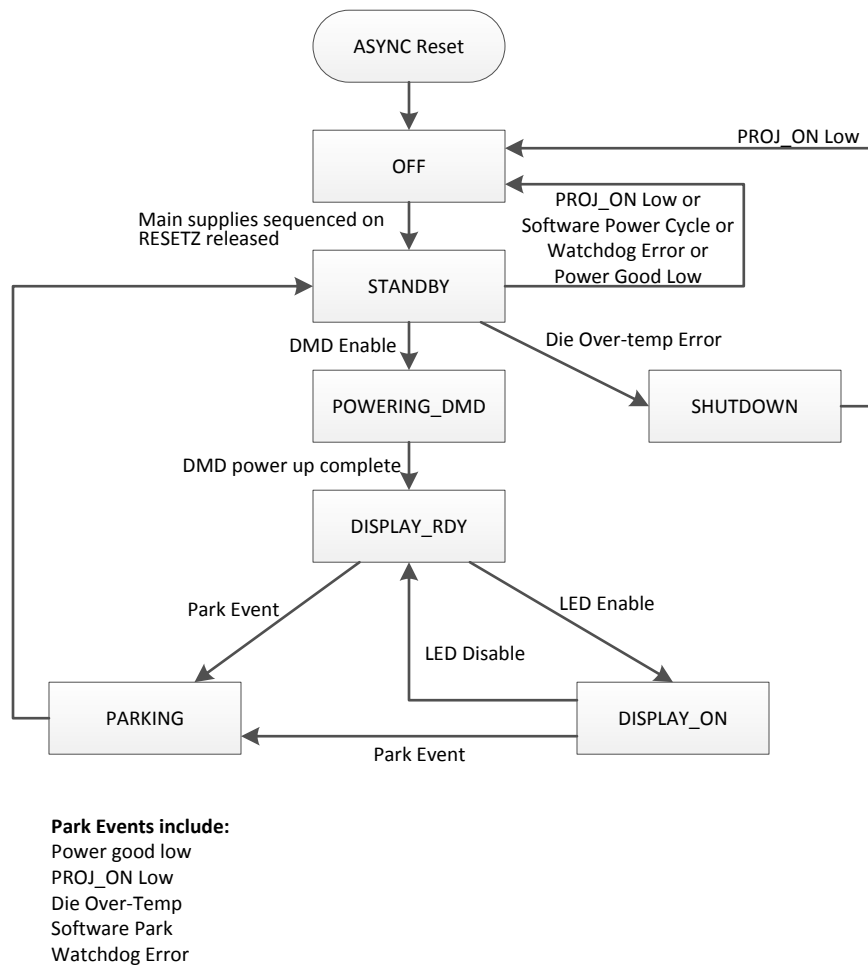

Figure 7-35. Top Level System States

7.4.1 OFF

The asynchronous internal reset of the device places system in this state. All supplies (DMD supplies, 1.1 V, 1.8 V, 3.3 V) are asynchronously disabled and RESETZ output to DLPC230S-Q1 is held low. Once the internal reset is released, communication over SPI2 is supported.

Exit from OFF state progresses to the STANDBY state. To exit OFF state, the following must all be true:

- VMAIN input monitor must show good status.
- PROJ_ON (projector on) input pin must be high.
- The die temperature warning must indicate the die temperature is below the warning threshold. Upon exit of OFF state and before entry to STANDBY, the external 1.1 V, 1.8 V, and 3.3 V supplies are powered on in sequence – first 1.1 V, then 1.8 V, then 3.3 V.

Internal monitors of 1.1 V, 1.8 V, and 3.3 V (and 6 V input on VIN_LD0T_5V) will hold off progression to STANDBY until all 4 rails are in operational range. After power is good, RESETZ output signal is held low for a specific period to ensure a proper reset cycle for the DLPC230S-Q1, and then it is released to transition to STANDBY.

7.4.2 STANDBY

Upon entry to STANDBY state, RESETZ is set high and DLPC230S-Q1 begins its boot process.

Exit options from STANDBY state include:

- A die over temp error sends system to SHUTDOWN state. An over temperature error in the STANDBY state means something is wrong with the system.
- PROJ_ON low sends to OFF state.
- Software commanded power cycle. System proceeds to OFF state.
- If either of the watchdog timers have been enabled by software and an error occurs, system proceeds to OFF state.
- If power unexpectedly goes bad, system proceeds to OFF state.
- DLPC230S-Q1 software begins to enable DMD voltages. Sends to POWERING_DMD state. This is the first step in DMD voltage enabling process.

During the STANDBY phase, the DLPC230S-Q1 software performs DMD and DLPC230S-Q1 sequencer configuration steps. The software is in charge of DMD voltage enable timing, interleaving necessary DMD configuration register writes, and DLPC230S-Q1 ASIC block configuration steps. After the DLPC230S-Q1 software begins enabling DMD voltages, the TPS99000S-Q1 proceeds to POWERING_DMD state.

7.4.3 POWERING_DMD

Once the DLPC230S-Q1 software begins enabling DMD voltages when in STANDBY, the system enters POWERING_DMD state. In this state, the DLPC230S-Q1 software performs all steps needed to properly configure and power up the DMD safely.

Exiting from POWERING_DMD state, the DLPC230S-Q1 software confirms that DMD is powered up. This sends the TPS99000S-Q1 to DISPLAY_RDY state. This is the last step in DMD voltage enabling process.

If a PROJ_ON low is received during power on, the TPS99000S-Q1 will still complete the power on sequence.

7.4.4 DISPLAY_RDY

In the display ready state, the DLPC230S-Q1 may enable illumination at any time.

Once the DLPC230S-Q1 software enables illumination, the TPS99000S-Q1 enters the DISPLAY state.

Exit conditions:

- Illumination enabled: go to DISPLAY_ON state. (HUD only)
- A *DMD park* event has occurred including power not good, PROJ_ON low, die over temp error, software park initiated, or software power cycle initiated. These events send the TPS99000S-Q1 to PARKING state.

Note: for headlight only applications the TPS99000S-Q1 does not enter the DISPLAY_ON state. Illumination turns on and off while remaining in DISPLAY_RDY.

7.4.5 DISPLAY_ON

System operational, image being displayed. Exit conditions:

- Illumination disabled: go to DISPLAY_RDY state.
- An internal *DMD park* event has occurred (including power not good or PROJ_ON low or die over temp error, or software park initiated, or software power cycle initiated - sends TPS99000S-Q1 to PARKING state.

7.4.6 PARKING

DMD parking is taking place. PARKZ output signal (to DLPC230S-Q1) is asserted low in this state. Timers count down time then the control for the DMD voltage regulators is disabled. Once the final hardware delay elapses, the next state is STANDBY.

7.4.7 SHUTDOWN

The shutdown state is entered only when a die over temperature condition is experienced. All switchable on chip activity is halted. The only exit conditions from this state are PROJ_ON low (0) or true power off. This state is readable via the 2nd diagnostic SPI port. All power supplies are disabled.

7.5 Register Maps

7.5.1 System Status Registers

ADDRESS	NAME	BITS	DESCRIPTION
Chip Revision ID, R-only, Reset Value 0000			
0x00	Unused	[15:8]	Unused
	Major	[7:4]	Major revision
	Minor	[3:0]	Minor revision
Status Set, R/W, Reset Value 0000 (Writing a 1 to any bit field sets flag)			
0x01	PG Fault Status	[15]	Asserted when any bin in user register 38h is set
	DM Max width limit	[14]	Maximum DM pulse width achieved. This may or may not be an error, depending on system operational mode
	VXPG Init	[13]	Power good timer for VOFS, VRST, or VBIAS expired
	Main SPI parity error	[12]	Parity error on a SPI1 port transaction occurred (command or write data) on previous command
	ADC block error	[11]	"OR" of all errors in ADC block. Refer to x0D to determine specific error.
	Checksum error 3	[10]	Checksum error in LED / dimming controller section
	Checksum error 2	[9]	Checksum error in light sensor conditioning section
	Checksum error 1	[8]	Checksum error in ADC sub-system section
	WD2	[7]	Watchdog #2 error
	WD1	[6]	Watchdog #1 error
	Top level state change	[5]	Indicates top level state machine has changed state. Can be used to indicate that the TPS99000S-Q1 has exited DISPLAY state unexpectedly due to a random fault
	Excessive brightness	[4]	Excessive brightness detector indicates an over bright fault condition
	VXPG Fault	[3]	Set 1 by hardware if power good fault occurs for VOFS, VRST, or VBIAS
	DIE Over temp warning	[2]	Thermal conditions on chip have reached the warning level. If temperature continues to rise, system will reach die over temp error temperature and emergency actions will be taken by TPS99000S-Q1
	DIE Over temp error	[1]	Thermal conditions on chip have reached the emergency/error. Emergency actions will be taken by TPS99000S-Q1 to protect the system. This error bit is non-maskable for PARKZ output
PROJ_ON_LOW	[0]	Projector ON input pin is low (produces a 1 on this status bit).	

ADDRESS	NAME	BITS	DESCRIPTION
General Status 1, R-only, Reset Value 0000			
0x05	Clock ratio monitor	[15:12]	Mid-scale reading (1000 ± 1) indicate approximately 30-MHz external signal has been applied
	Open	[11:8]	Reserved
	Last Reset (2:0)	[7:5]	Root cause of last reset cycle, last pass through the OFF state. "000" – true power on cycle, internal reset set/release "001" – PROJ_ON went low "010" – watchdog timer 1 error "011" – watchdog timer 2 error "100" – die over temperature error "101" – SW power cycle command all others unused
	Top State (4:0)	[4:0]	Top level state machine current state 0x00 = SHUTDOWN 0x01 = Internal initialization 0x02 = OFF 0x03 = Internal initialization 0x04 = Initializing 1P1V 0x05 = Initializing 1P8V 0x06 = Initializing 3P3V 0x07 = De-assert RESETZ 0x08 = STANDBY 0x09 = VOFFSET enabled 0x0A = VBIAS enabled 0x0B = VRESET enabled 0x0C = DISPLAY READY 0x0D = DISPLAY ON 0x0E = Parking initialized 0x0F = VBIAS and VRESET disabled 0x10 = VOFFSET disabled 0x11 = DMD voltage discharge

7.5.2 ADC Control

ADDRESS	NAME	BITS	DESCRIPTION
ADC Block Status SET, Read/Write, Reset Value 0000 (Writing 1 to any bit field sets flag. OR of all ADC error bits feed into single ADC error bit in main status.)			
0x0D	Unused	[15:8]	Reserved
	AD3 Command Stop-bit Error	[7]	Indicates that a stop bit was missing
	ADC Timeline Error	[6]	Indicates that a new command was received while previous command was still in progress
	Command error	[5]	An error was detected on a serial bus command
	Parity error detected	[4]	A parity error in bit stream was detected
	Ch2 underflow	[3]	ADC conversion results presented in channel two register experienced an underflow
	Ch2 saturated	[2]	ADC conversion results presented in channel two register are saturated
	Ch1 underflow	[1]	ADC conversion results presented in channel one register experienced an underflow
	Ch1 saturated	[0]	ADC conversion results presented in channel one register are saturated

7.5.3 General Fault Status

ADDRESS	NAME	BITS	DESCRIPTION
General Fault Status, R-only, Reset Value 0000, Value of 1 indicates a Fault			
0x38	VBIAS Powergood Fault	[15]	VBIAS is below the minimum specified voltage
	VRST Powergood Fault	[14]	VRESET is below the minimum specified voltage
	VOFS Powergood Fault	[13]	VOFFSET is below the minimum specified voltage
	Powergood 1 Fault	[12]	VMAIN or AVDD rail is below the minimum specified voltage (Logical OR).
	Powergood 2 Fault	[10]	At least one of 1.1 V, 1.8 V, 3.3 V, and 6 V supplies is below the minimum specified voltage (Logical OR).
	ADC 3V LDO Powergood Fault	[9]	ADC 3V LDO is below the minimum specified voltage
	ADC 3V LDO Over Voltage Fault	[8]	ADC 3V LDO is above the maximum specified voltage
	TIA 3V LDO Powergood Fault	[7]	TIA 3V LDO is below the minimum specified voltage
	TIA 3V LDO Over Voltage Fault	[6]	TIA 3V LDO is above the maximum specified voltage
	TIA5 LDO Over Voltage Fault	[5]	TIA 5V LDO is above the maximum specified voltage
	TIAM8 LDO Powergood Fault	[4]	Negative 8 V Photo Diode Bias LDO is below the minimum specified voltage
	TIAM8 LDO Over Voltage Fault	[3]	Negative 8 V Photo Diode Bias LDO is above the maximum specified voltage
	V3P3 Powergood Fault	[2]	3.3 V is below the minimum specified voltage
	V1P8 Powergood Fault	[1]	1.8 V is below the minimum specified voltage
	V1P1 Powergood Fault	[0]	1.1 V is below the minimum specified voltage

8 Application and Implementation

Note

Information in the following applications sections is not part of the TI component specification, and TI does not warrant its accuracy or completeness. TI's customers are responsible for determining suitability of components for their purposes. Customers should validate and test their design implementation to confirm system functionality.

8.1 Application Information

The DLP553x-Q1 chipset is designed to support projection-based automotive applications such as head-up displays (HUD) and high resolution headlights.

The DLP553x-Q1 chipset consists of three components—the DLP553x-Q1 (DMD), the DLPC230S-Q1, and the TPS99000S-Q1. The DMD is a light modulator consisting of tiny mirrors that are used to form and project images. The DLPC230S-Q1 is a controller for the DMD; it formats incoming video and controls the timing of the DMD illumination sources and the DMD in order to display the incoming video. The TPS99000S-Q1 is a controller for the illumination sources (LEDs or lasers) and a management IC for the entire chipset. In conjunction, the DLPC230S-Q1 and the TPS99000S-Q1 can also be used for system-level monitoring, diagnostics, and failure detection features.

8.2 Typical Applications

There are two configurations for this chip, HUD and headlight. [Table 8-1](#) shows the differences for the pin connections between the two configurations.

Table 8-1. Pin Configuration Differences for HUD and Headlight

PIN	NAME	DESCRIPTION	HUD	HEADLIGHT
12	COMPOUT	Photodiode (PD) Interface High-speed comparator output	Connect to DLPC230S-Q1 GPIO_02	No connect
15	SYNC	External LED buck driver sync strobe output	See Section 8.2.1.2.3	No connect
18	D_EN	LED Interface; Buck High-Side FET Drive Enable	Connect to DLPC230S-Q1 D_EN (GPIO_04)	Connect to DLPC230S-Q1 D_EN (GPIO_04) or ground
19	S_EN	LED Bypass Shunt Strobe Input	Connect to DLPC230S-Q1 S_EN (GPIO_03)	Connect to DLPC230S-Q1 S_EN (GPIO_03) or ground
20	LED_SEL_0	LED Enable Strobe 0 Input	Connect to DLPC230S-Q1 PMIC_LEDSEL_0	Connect to DLPC230S-Q1 PMIC_LEDSEL_0 or ground
21	LED_SEL_1	LED Enable Strobe 1 Input	Connect to DLPC230S-Q1 PMIC_LEDSEL_1	Connect to DLPC230S-Q1 PMIC_LEDSEL_1 or ground
22	LED_SEL_2	LED Enable Strobe 2 Input	Connect to DLPC230S-Q1 PMIC_LEDSEL_2	Ground
23	LED_SEL_3	LED Enable Strobe 3 Input	Connect to DLPC230S-Q1 PMIC_LEDSEL_3	Ground
38	DRV_EN	Drive enable for LM3409	Driver select enable	Resistor to ground
39	CMODE	Capacitor selection output (allows for a smaller capacitance to be used in CM mode for less over/under shoot). Open drain	See Section 7.3.1.4.7	No connect
40	DMUX0	Digital test point output	Either connect to test point or leave unconnected. Do not ground.	Either connect to test point or leave unconnected. Do not ground.
41	DMUX1	Digital test point output	Either connect to test point or leave unconnected. Do not ground.	Either connect to test point or leave unconnected. Do not ground.
43	S_EN1	Low resistance shunt NFET drive enable [High means shunt active]	See Section 7.3.1.3.3	Shunt enable / No connect
44	S_EN2	High resistance shunt NFET drive enable [High means shunt active]	See Section 7.3.1.3.3	No connect

Table 8-1. Pin Configuration Differences for HUD and Headlight (continued)

PIN	NAME	DESCRIPTION	HUD	HEADLIGHT
45	R_EN	Red channel select. Drive for low side NFET	FET enable	FET enable / No connect
46	G_EN	Green channel select. Drive for low side NFET	FET enable	FET enable / No connect
47	B_EN	Blue channel select. Drive for low side NFET	FET enable	FET enable / No connect
57	AMUX1	Analog Test Mux Output 1	Either connect to test point or leave unconnected. Do not ground.	Either connect to test point or leave unconnected. Do not ground.
61	AMUX0	Analog Test Mux Output 0	Either connect to test point or leave unconnected. Do not ground.	Either connect to test point or leave unconnected. Do not ground.
62	VIN_LDOT_M8	Dedicated TIA Interface –8 V(nom) LDO external regulation FET drive signal for -8 V regulator	Refer to Section 7.3.6	Connect as described in Section 7.3.6 or do not connect (select NC option in SW).
63	VLDOT_M8	Dedicated TIA Interface –8 V(nom) LDO filtered supply (regulated voltage feedback)	Refer to Section 7.3.6	Connect as described in Section 7.3.6 or do not connect (select NC option in SW).
76	R_IADJ	External resistance for IADJ voltage to current transformation	See Section 8.2.1.2.3	Ground
77	IADJ	Current output used to adjust external LED controller drive current set point	See Section 8.2.1.2.3	Ground
85	ADC_IN1	External ADC Channel 1, see Table 7-2	Connect to LED anode with voltage divider	No connect / Optional (customer use)
86	ADC_IN2	External ADC Channel 2, see Table 7-2	Optional (LED input voltage)	No connect / Optional (customer use)
88	ADC_IN3	External ADC Channel 3, see Table 7-2	No connect / Optional (customer use)	No connect / Optional (customer use)
90	ADC_IN4	External ADC Channel 4, see Table 7-2	No connect / Optional (customer use)	No connect / Optional (customer use)
92	ADC_IN5	External ADC Channel 5, see Table 7-2	No Connect / Optional (Thermistor)	No connect / Optional (customer use)
93	ADC_IN6	External ADC Channel 6, see Table 7-2	No Connect / Optional (Thermistor)	No connect / Optional (customer use)
94	ADC_IN7	External ADC Channel 7, see Table 7-2	No Connect / Optional (Thermistor)	No connect / Optional (customer use)

Pull-down resistors are required on the pins in the below table to avoid a floating input during the power-up and power-down conditions.

Table 8-2. Pull-down Resistor Requirements

PIN	NAME	TYP
5	ADC_MOSI	10 kΩ
6	WD1	10 kΩ
16	SEQ_START	10 kΩ
17	SEQ_CLK	10 kΩ
18	D_EN ⁽¹⁾	10 kΩ
19	S_EN ⁽¹⁾	10 kΩ
20	LED_SEL_0 ⁽¹⁾	10 kΩ
21	LED_SEL_1 ⁽¹⁾	10 kΩ
22	LED_SEL_2 ⁽¹⁾	10 kΩ
23	LED_SEL_3 ⁽¹⁾	10 kΩ
27	SPI1_CLK	10 kΩ
30	SPI1_DIN	10 kΩ

Table 8-2. Pulldown Resistor Requirements (continued)

PIN	NAME	TYP
31	SPI2_DIN	10 kΩ
34	SPI2_CLK	10 kΩ
49	DMD_VOFFSET ⁽²⁾	56 kΩ
50	DMD_VBIAS ⁽²⁾	110 kΩ
51	DMD_VRESET ⁽²⁾	68 kΩ

- (1) If these pins are not connected to the DLPC230S-Q1 (as in a Headlight configuration) then they may be tied directly to ground without a pull-down resistor.
- (2) Resistor pull downs are required to create a minimum load for DMD_VOFFSET, DMD_VBIAS, and DMD_VRESET. Each of these pull-downs should provide a load from 0.1mA to 1mA. If the -8 V LDO is used, then the pull down for DMD_VRESET may be eliminated. If only one or zero TIAs are used, then these pull downs may draw up to 1mA of current.

8.2.1 HUD

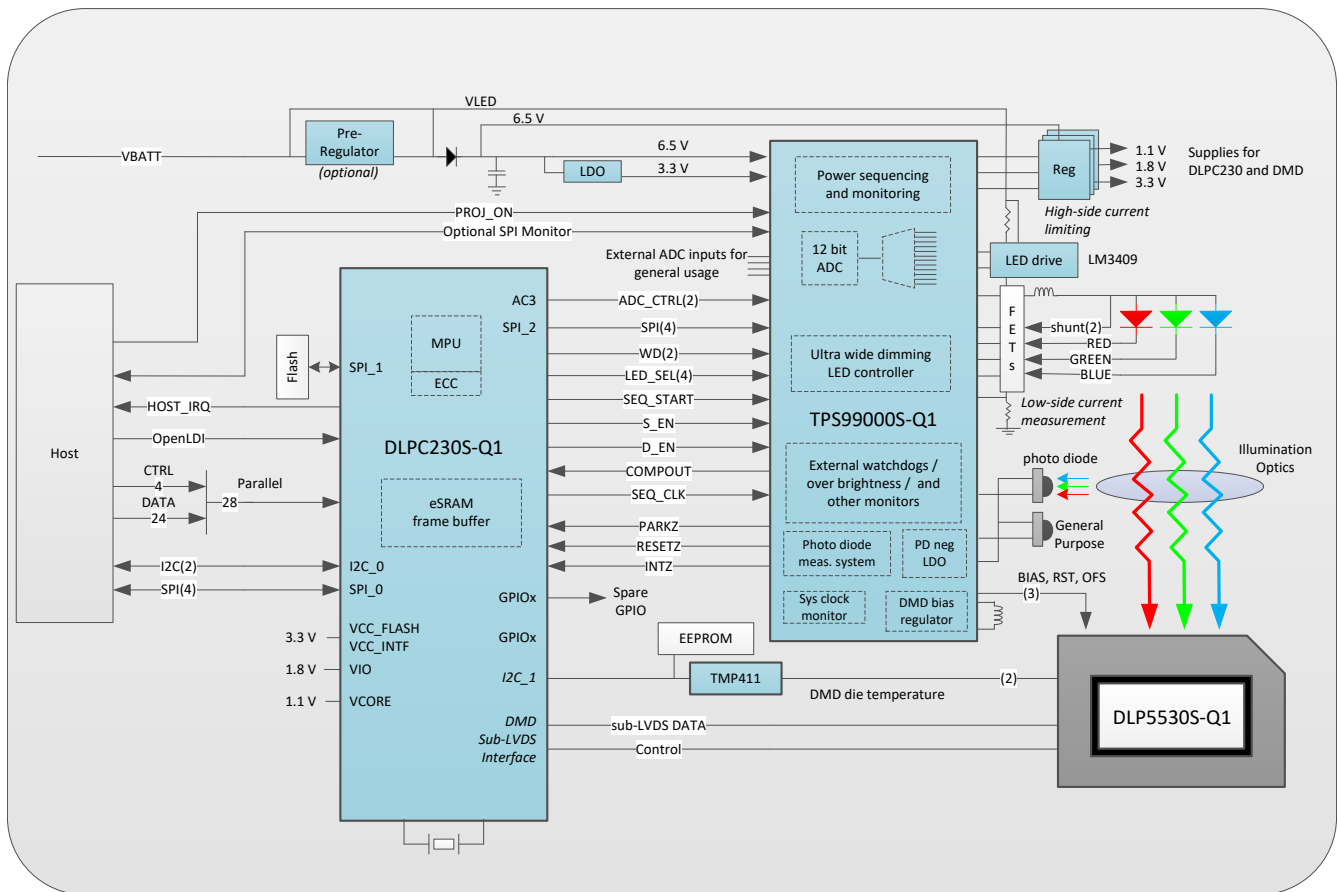

Figure 8-1. HUD System Block Diagram

8.2.1.1 Design Requirements

The DLPC230S-Q1 is a controller for the DMD and the timing of the RGB LEDs in the HUD. It requests the proper timing and amplitude from the LEDs to achieve the requested color and brightness from the HUD across the entire operating range. It synchronizes the DMD with these LEDs in order to generate full-color video requested from the host.

The DLPC230S-Q1 receives inputs from a host processor in the vehicle. The host provides commands and input video data. Read and write (R/W) commands can be sent using either the I²C bus or SPI bus. The bus that is not being used for R/W commands can be used as a read-only bus for diagnostic purposes. Input video can be sent over an OpenLDI bus or a parallel 24-bit bus. The SPI flash memory provides the embedded software for the

DLPC230S-Q1's ARM core, color calibration data, and default settings. The TPS99000S-Q1 provides diagnostic and monitoring information to the DLPC230S-Q1 using an SPI bus and several other control signals such as PARKZ, INTZ, and RESETZ to manage power-up and power-down sequencing. The DLPC230S-Q1 interfaces to a TPM411 via I²C for temperature information.

The outputs of the DLPC230S-Q1 are LED drive information to the TPS99000S-Q1, control signals to the DMD, and monitoring and diagnostics information to the host processor. Based on a host requested brightness and the operating temperature, the DLPC230S-Q1 determines the proper timing and amplitudes for the LEDs. It passes this information to the TPS99000S-Q1 using an SPI bus and several additional control signals such as D_EN, S_EN, and SEQ_START. It controls the DMD mirrors by sending data over a sub-LVDS bus. It can alert the host about any critical errors using a HOST_IRQ signal.

The TPS99000S-Q1 is a highly-integrated mixed-signal IC that controls DMD power, the analog response of the LEDs, and provides monitoring and diagnostics information for the HUD system. The power sequencing and monitoring blocks of the TPS99000S-Q1 properly power up the DMD and provide accurate DMD voltage rails, and then monitor the system's power rails during operation. The integration of these functions into one IC significantly reduces design time and complexity. The highly accurate photodiode (PD) measurement system and the dimming controller block precisely control the LED response. This enables a DLP technology HUD to achieve a very high dimming range (> 5000:1) with accurate brightness and color across the temperature range of the system. Finally, the TPS99000S-Q1 has several general-purpose ADCs that designers can use for system-level monitoring, such as over-brightness detection.

The TPS99000S-Q1 receives inputs from the DLPC230S-Q1, power rail voltages for monitoring, a photodiode that is used to measure LED response, the host processor, and potentially several other ADC ports. The DLPC230S-Q1 sends commands to the TPS99000S-Q1 over a SPI port and several other control signals. The TPS99000S-Q1 includes watchdogs to monitor the DLPC230S-Q1 and ensure that it is operating as expected. The power rails are monitored by the TPS99000S-Q1 to detect power failures or glitches and request a proper power down of the DMD in case of an error. The photodiode's current is measured and amplified using a transimpedance amplifier (TIA) within the TPS99000S-Q1. The host processor can read diagnostics information from the TPS99000S-Q1 using a dedicated SPI bus. Additionally the host can request the system to be turned on or off using a PROJ_ON signal. The TPS99000S-Q1 has several general-purpose ADCs that can be used to implement other system features such as over-brightness and over-temperature detection.

The outputs of the TPS99000S-Q1 are LED drive signals, diagnostic information, and error alerts to the DLPC230S-Q1. The TPS99000S-Q1 has signals connected to the LM3409 buck controller for high power LEDs and to discrete hardware that control the LEDs. The TPS99000S-Q1 can output diagnostic information to the host and the DLPC230S-Q1 over two SPI busses. It also has signals such as RESETZ, PARKZ, and INTZ that can be used to trigger power down or reset sequences.

The DMD is a micro-electro-mechanical system (MEMS) device that receives electrical signals as an input (video data) and produces a mechanical output (mirror position). The electrical interface to the DMD is a sub-LVDS interface driven with the DLPC230S-Q1. The mechanical output is the state of more than 1.3 million mirrors in the DMD array that can be tilted $\pm 12^\circ$. In a projection system, the mirrors are used as pixels in order to display an image.

8.2.1.2 Application Design Considerations

8.2.1.2.1 Photodiode Considerations

Placement of the photodiode within the optical path is critical to system performance. Carefully optimizing the placement and electrical response of the photodiode will yield the widest dynamic range for dimming. Treatment of photodiode considerations are addressed in the *Photodiode Selection and Placement Guide* (DLPA082).

Several factors for the photodiode should be considered:

- **Position:**
 - Ideally, a position in the illumination path ([Figure 8-2](#)) should be located that produces strong, but also balanced amplitude signal responses from each of the three LEDs at the system's target white point. Imbalance between the three channels due to non-ideal placement of the detector will limit dynamic range of the dimming system. The TIA supports an RGB trim function to help re-balance an imbalanced system.

This feature is useful for completing the process of optimizing the balance of the amplitude signal responses from each LED. But it is still advisable to take care in the design of the illumination path such that the natural balance of the colors is as ideal as practical.

- An additional consideration when determining position of photodiode is back scattered light from the projection path. Some amount of *on state* light will reflect backwards from the surfaces of the projection lens and other objects in the light path after the DMD. If the photodiode is placed in a position that is illuminated by this back scattered light, the photodiode will see a mixture of true illumination light plus this back scattered output light. If the back scattered light is significant, the illumination control loop will be impacted. Also, the back scatter is dependent on the video content (i.e. a solid white pattern may cause more back scatter than a solid black pattern), which impacts the full-on full-off contrast.
- **Irradiance on the Photodiode:**
 - It is also important that the irradiance on the photodiode is not too high or too low. A high magnitude of irradiance can cause saturation and slower response from the photodiode. This varies depending on the specific photodiode selected for use. The TPS99000S-Q1 provides a negative LDO and negative voltage source to provide a low noise -8 V reference for reverse biasing the photodiode. Reverse biasing the photodiode (photo conductive mode) increases the amount of irradiance the photodiode can accept without saturating as compared to a zero bias case (photovoltaic mode). On the other hand, a low magnitude of irradiance can make the system more susceptible to noise, including photodiode dark current. It is best to operate at photodiode current levels high enough so that dark current is negligible to avoid potential issues due to other noise sources (noise on cabling, grounding, etc).
- **Cable to remote PD placement:**
 - If the photodiode is located remotely it is recommended to use a low capacitance cable and minimize the cable length. At a minimum: for noise rejection, use a one conductor shielded cable with the photodiode bias (cathode) connected to the cable shield and the photodiode output (anode) connected to the inner conductor. Better noise rejection is possible using shielded two conductor cables with the shield tied to a low noise ground. Experiments may be necessary to determine an optimal photodiode position to achieve adequate response balance between the colors and an acceptable irradiance level. Care must be taken to not exceed the maximum total photodiode capacitance (diode plus cable and connectors) as specified in [Section 6.5](#). TIA design includes adjustable feedback capacitance to optimize response for specific solutions. DLPC230S-Q1 flash configuration options allow tuning of this feedback capacitance for optimal slew rate and stability performance.

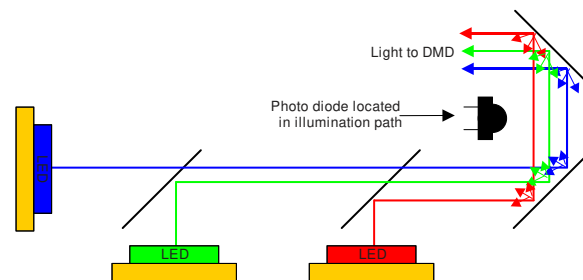

Figure 8-2. Photodiode Placement

The photodiode conditioning circuits include several features to improve performance and integration:

- Independent red, green and blue parameters for gain and offset
- Selectable feedback capacitance
- Integrated negative LDO, to provide photodiode reverse bias

8.2.1.2.2 LED Current Measurement

The TPS99000S-Q1 includes a dedicated ADC channel for LED current measurement. The *blanking current* management process in system software, described in the [Section 7.3.1.3](#) section, relies on this measurement to coordinate the blanking current to the photo feedback current. The software measures the actual LED current in photo feedback (per color) and also measures the blanking current. The blanking current setting is fine trimmed during system operation to a level ideal for optimizing the initial current of each light pulse. As such, it is critical

to system performance that this LED current measurement is as noise free as practical. Using a *Kelvin* connection to the low side sense resistor, and an RC filter is recommended to filter switching ripple, as illustrated in [Figure 8-3](#). The Kelvin resistors should be < 100 Ω each and should have a tolerance of less than 0.5% matched resistors.

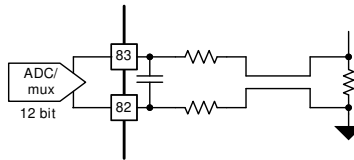

Figure 8-3. LED Current Measurement Wiring

8.2.1.2.3 Setting the Current Limit

The current limit of the LM3409 is determined by the current draw of the IADJ pin of the TPS99000S-Q1, which is controlled by an internal DAC and an external resistor connected to the R_IADJ pin of the TPS99000S-Q1. The approximate peak current limit can be calculated by the following equation:

$$I_{LIM} = \frac{V_{DAC}}{R_{ADJ}} * \frac{R_{CSP}}{R_{HSS}}$$

Where:

- V_{DAC} is the voltage of the current control DAC.
- R_{ADJ} is the resistor attached to the R_IADJ pin of the LM3409. Do to the max current this circuit can output, it is recommended that this value be 1 kΩ or higher
- R_{SCP} is the resistor attached to the CSP pin of the LM3409. Use the same value for R_{CSN} .
- R_{HSS} is the high side sense resistor of the LM3409 control circuit.

current away from the LED. Latency in the photo feedback loop will result in the light climbing higher than the threshold as shown in Figure 8-5. The amount of light that occurs after the threshold is reached (shown as hashed green area) is the majority of the light at the lowest discontinuous mode brightness levels. Figure 8-5 also shows that a reduction in photo feedback DAC level by a factor of two does not reduce the total light pulse power by a factor of two because of the light that occurs after the threshold. The amount of light overrun after the threshold is a function of the photo feedback latency, inductor initial current, capacitance in parallel with the LED, LED voltage to current characteristics and shunt FET timing.

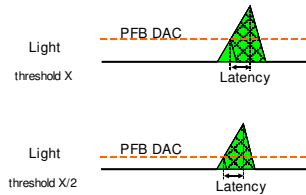

Figure 8-5. Discontinuous Pulse Overrun

8.2.1.2.6 Transimpedance Amplifiers (TIAs, Usage, Offset, Dark Current, Ranges, RGB Trim)

The TPS99000S-Q1 includes support for up to 2 system photodiode inputs.

TIA1 is used as the primary photo feedback channel. It supports 14 unique gain settings, spanning 0.75 kV/A to 288 kV/A. In addition, these gain settings can be adjusted downward by a high resolution trim function, in a range of 1.0x to 0.2x. This trim function has independent RGB settings, supporting color rebalancing (such as trimming RGB feedback signals so that white light produces roughly equal voltages at TIA output for each color). Color rebalancing helps keep all three color channels in the working voltage range to maximize dynamic range. Figure 8-6 shows the TIA1 model.

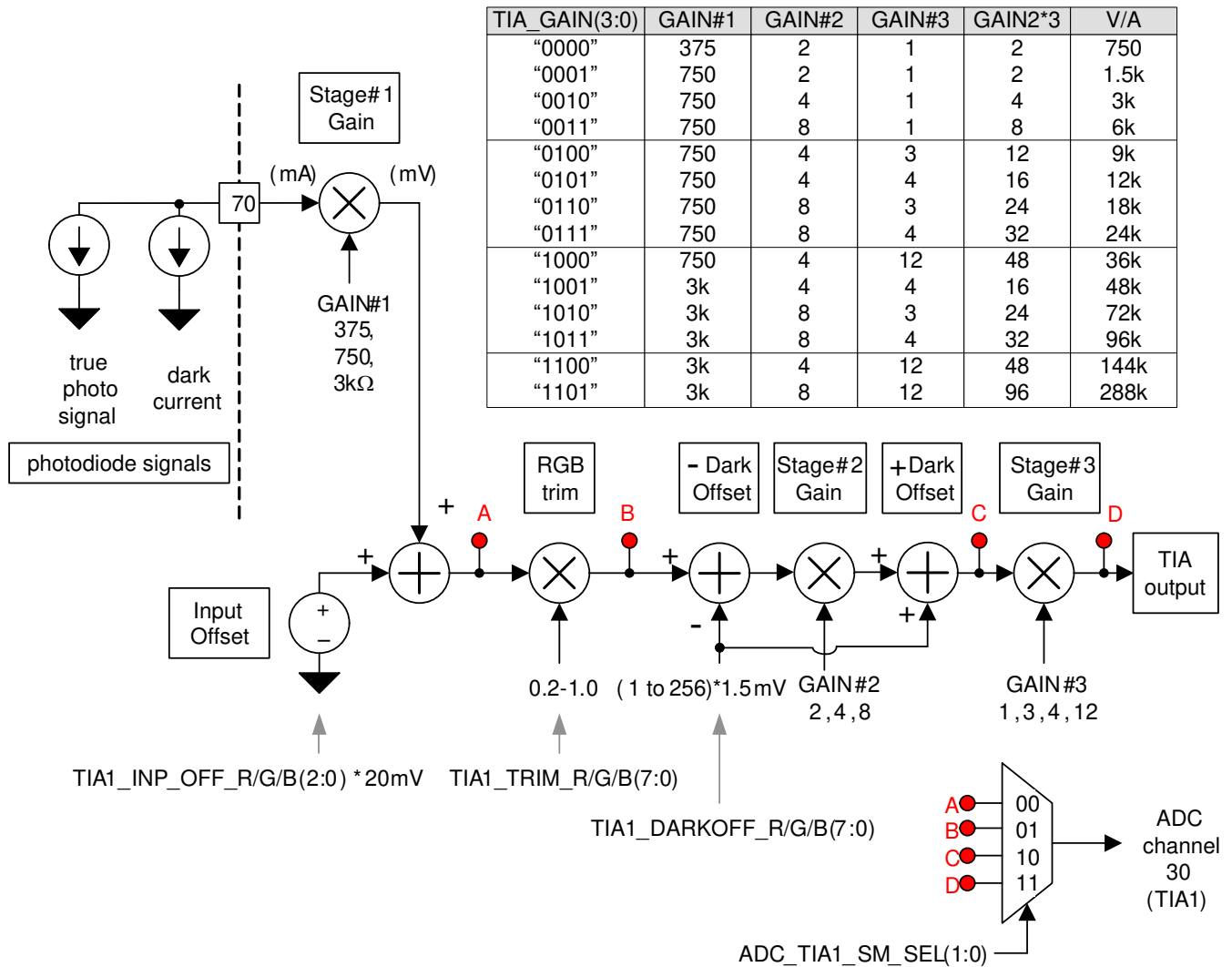

Figure 8-6. TIA1 Trim, Offset, and Gain Stages

TIA2 supports a single trim value and single *darkoffset* value, but is otherwise identical to TIA1.

Note

TIA2 shall only be used for diagnostic purposes, and it is not recommended to use for primary photo feedback amplification. If TIA2 is used to measure projector output or illumination light, this lack of multiplexed RGB parameters for trim and dark offset will limit its usage to looking only at one color at a time for situations where highest gain settings are used in combination with high color to color electrical response imbalance. For lower gain settings or situations where the photodiode responses are naturally balanced, all 3 colors likely can be monitored with TIA2.

The trim settings may be used to lower the total gain of the TIA amplifiers. This provides flexibility to allow higher photo diode currents to be used without saturating the TIA. For example, with the trim setting limited to 0.5x, a 0.75-kV/A gain selection can be considered a 0.375-kV/A effective gain setting. The supported maximum photo diode current doubles in this case.

Both TIAs are designed to support a wide range of photo diode capacitances. A variable, internal compensation capacitor network is available to tune the circuit for maximum performance for a given photo diode and cable combination.

Both TIAs can be independently enabled or disabled. When a TIA is disabled, it is placed in a low power mode to optimize power consumption.

TIA2 can be used for an over-brightness detection input or ADC measurements. It supports two outputs: 1) a higher bandwidth output, optimized for measuring photo diode response of CM bit slice light pulses, and 2) a much lower bandwidth output, optimized for measuring light flux filter over periods spanning at least one video frame. TIA1 supports these same two outputs, plus one more: a very high bandwidth output used for the real-time color control loop photo feedback. See [Section 6.5](#) for BW and slew rate specifications for this use case.

One potential use for TIA2 is for system level brightness detection.

9 Power Supply Recommendations

The TPS99000S-Q1 requires two power inputs and also provides several power outputs, as well as controlling additional external power supplies. The power supply architecture is explained in [Section 9.3](#).

9.1 TPS99000S-Q1 Power Supply Architecture

- 6.5 V is the recommended operating voltage for HUD designs because the LM3409 locks out at voltages below 6 V; therefore, the system designer may choose 6.5 V to power both devices. If the LM3409 is not used with the TPS99000 (as in most headlight designs), then any voltage may be used that meets the [Section 6.3](#) of the device.
- 3.3 V (LDO recommended)

9.2 TPS99000S-Q1 Power Outputs

- DMD Required Voltages:
 - DMD_VOFFSET
 - DMD_VBIAS
 - DMD_VRESET
- –8 V Photodiode Bias
- Internally used LDOs. These are not designed to be used externally, but are listed here as they require external bypass capacitors:
 - 5 V
 - 3.3 V TIA
 - 3.3 V ADC

9.3 Power Supply Architecture

The power supply architecture depends on the amount of power required for the illumination source. For HUD applications which require precise color and white point control, it is highly recommended to pre-regulate the illumination power supply, as voltage variations can cause variations in the LED output. For non-color critical applications, the designer may choose to completely isolate the illumination driver. In addition, if 2 or more LEDs are driven in series, then the pre-regulated voltage must be higher than the voltage of the LEDs. The different architectures are shown below.

Note that the architectures make use of the LM25118 as a pre-regulator. This part uses a buck-boost architecture which allows it to supply the required 6.5 V with a battery voltage input of 6 V to 18 V. If the battery input can be assured to be above the 6.5 V output voltage, then a buck architecture can be used instead, resulting in BOM savings.

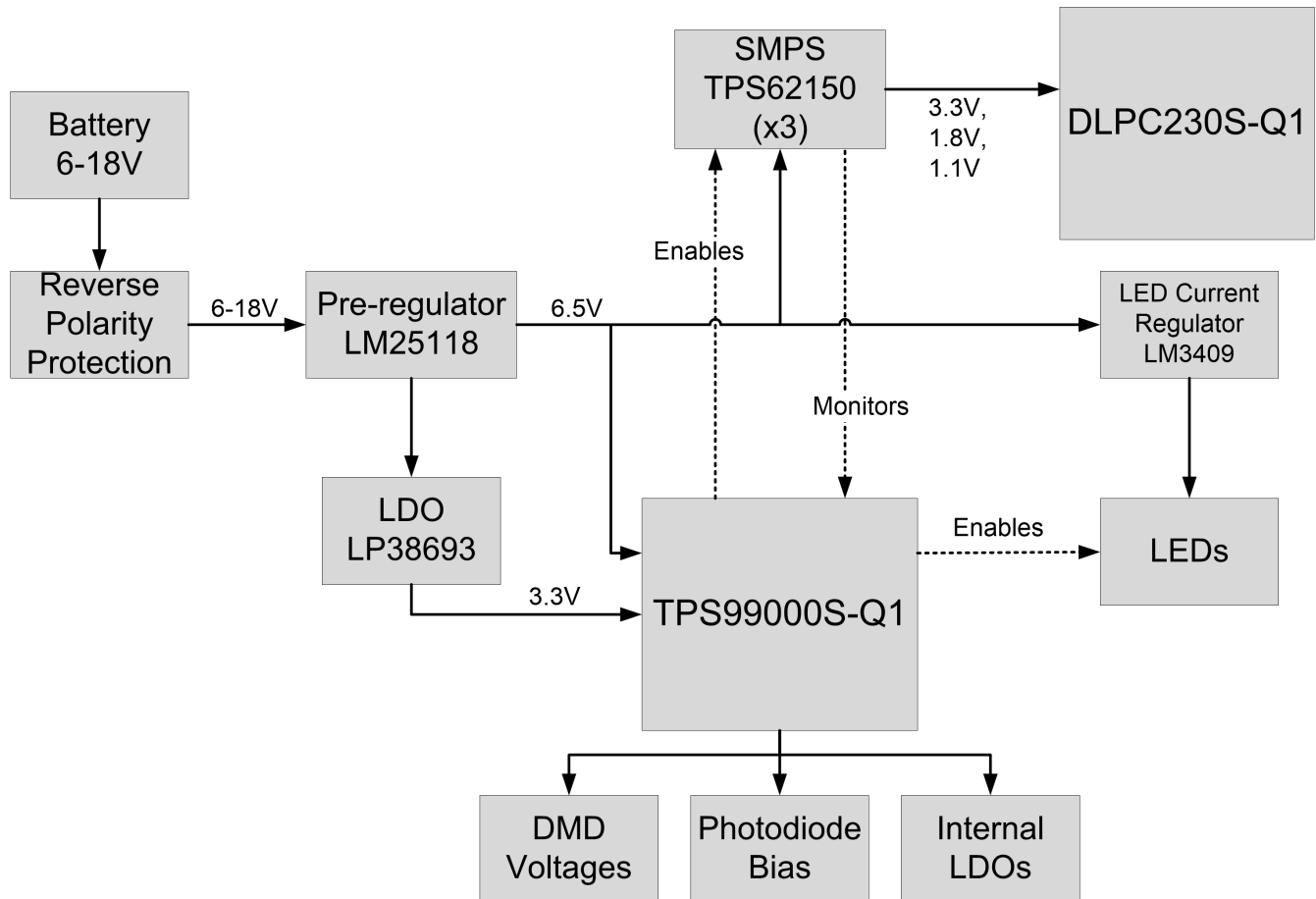

Figure 9-1. Architecture Number 1: HUD Application with LED Forward Voltage Less Than 5 V

In this application, the same pre-regulator is used to power the 6.5 V rail as well as the LM3409. Since the LM3409 input voltage must be kept above 6 V, the pre-regulator is set to 6.5 V.

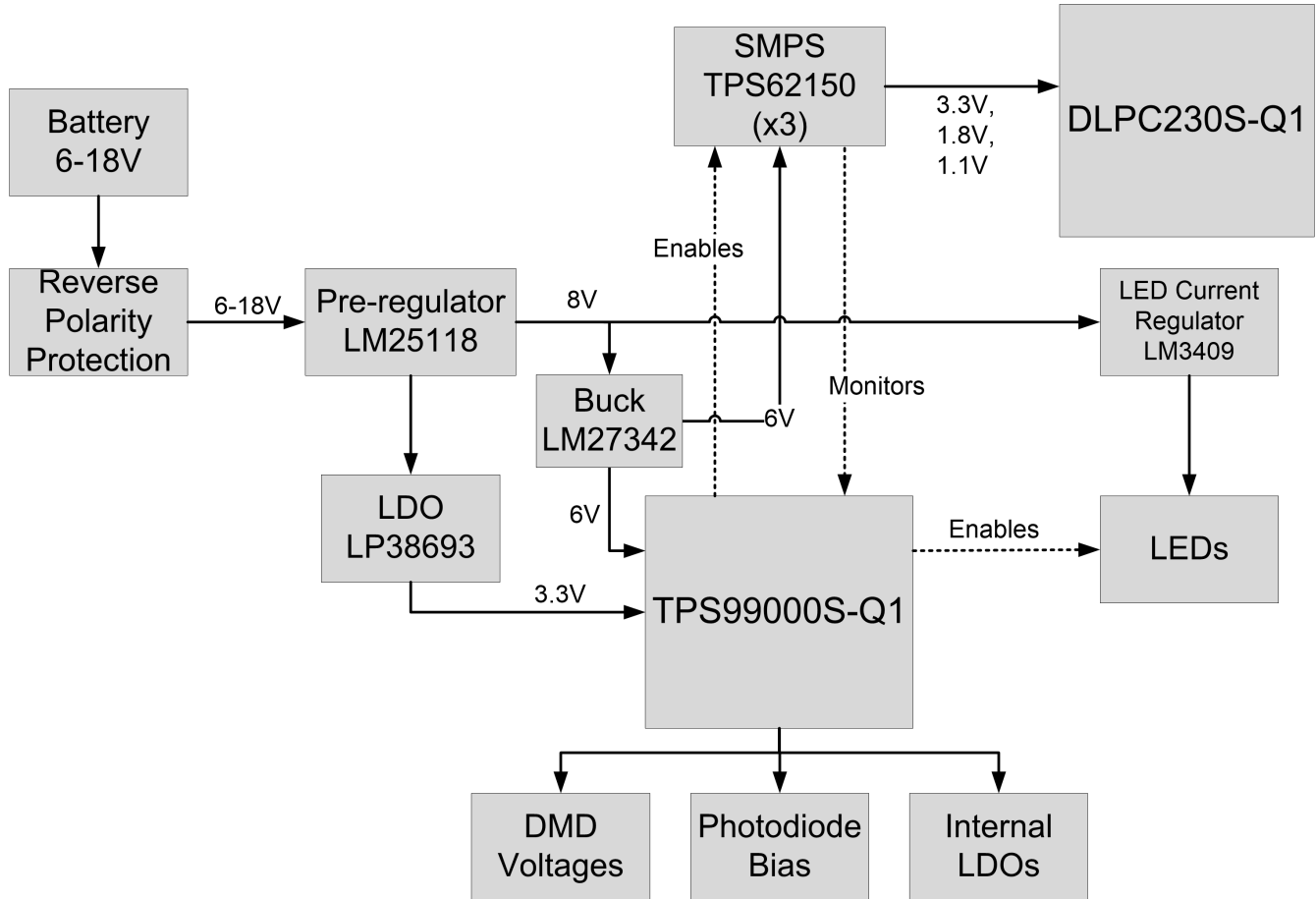

Figure 9-2. Architecture Number 2: HUD Application with Two LEDs in Series Configuration

In this application, the pre-regulator must be designed to operate at a higher output voltage in order to drive 2 LEDs in series. Because the TPS99000S-Q1 requires a VIN from 5.5 V to 7 V, a small buck regulator is used to generate a 6 V power rail.

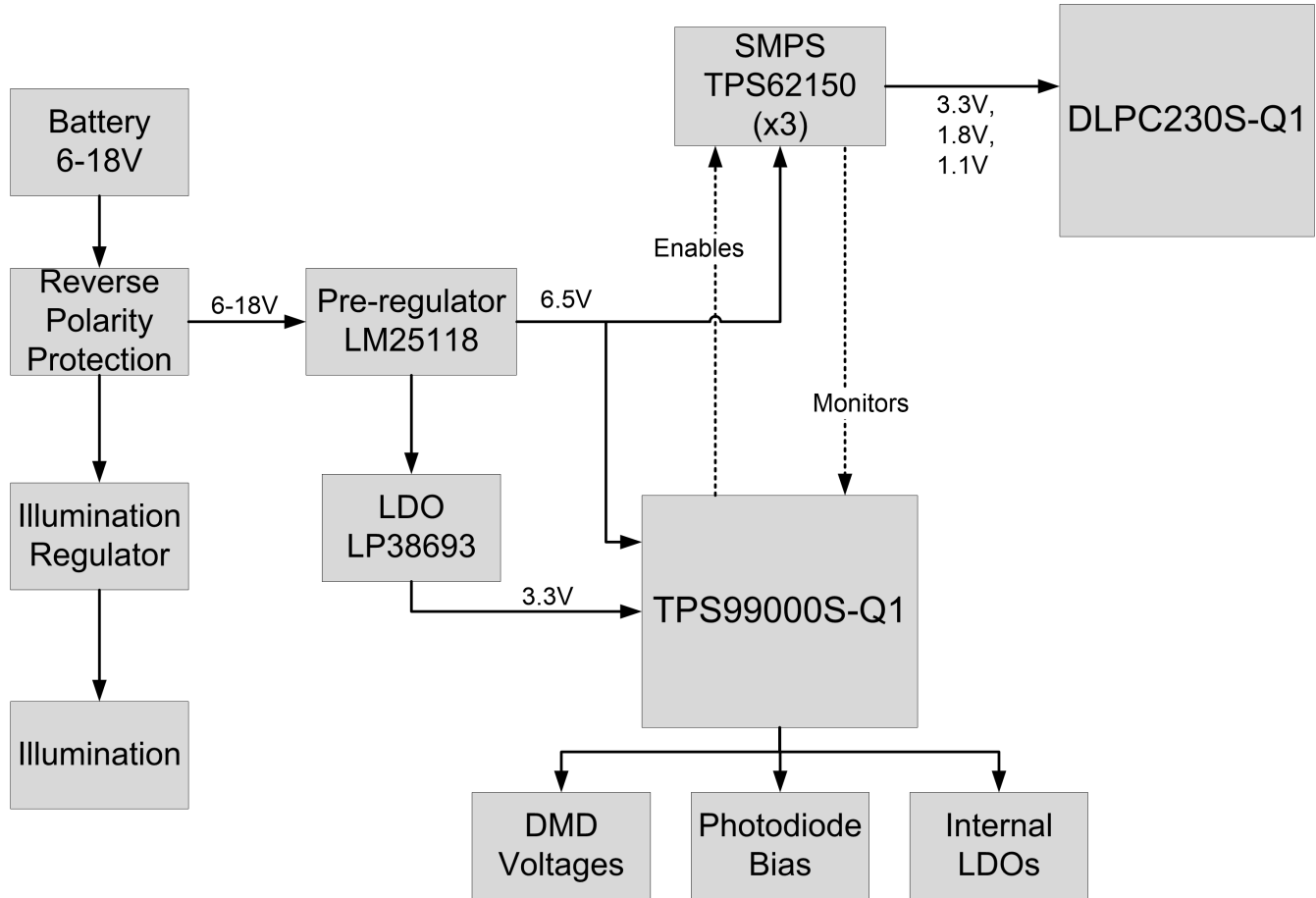

Figure 9-3. Architecture Number 3: Headlight Application with Independent Illumination

In this application, the power used to drive the illumination is separate from the TPS99000S-Q1. This is possible in applications where the illumination driver can be very simple. Although the LM25118 is shown here, a different regulator would likely be selected in this application because the maximum current requirements are much less with the illumination power path removed.

10 Layout

10.1 Layout Guidelines

The TPS99000S-Q1 is both a power and precision analog IC. As such, care must be taken to the layout of certain signals and circuits within the system. Along with general layout best practices, pay attention to the following areas of detail, which are discussed in this document.

- Power/high current signals
- Sensitive analog signals
- High speed digital signals
- High power current loops
- Kelvin sensing connections
- Ground separation

10.1.1 Power/High Current Signals

The TPS99000S-Q1 contains two blocks that switch a relatively high amount of current. The first of these is the switching regulator which generates the voltages used by the DMD. The second is the integrated LED FET gate drivers.

The DMD regulator consists of the following pins of the TPS99000S-Q1 :

Table 10-1. TPS99000S-Q1 DMD Regulator Pins

PIN	NAME	PEAK BOARD CURRENT
49	DMD_VOFFSET	800 mA
50	DMD_VBIAS	800 mA
51	DMD_VRESET	800 mA
52	DRST_LS_IND	800 mA
53	DRST_PGND	800 mA
54	DRST_HS_IND	800 mA
55	VIN_DRST	800 mA
56	VSS_DRST	800 mA

The value of 800 mA for these pins relates to the peak current through the inductor due to the nature of the switching regulator architecture. The DC current for these paths will be closer to the load current drawn by the DMD.

The high current LED gate drive pins consist of the following pins of the TPS99000S-Q1:

Table 10-2. TPS99000S-Q1 High Current LED Gate Driver Pins

PIN	NAME	PEAK BOARD CURRENT
42	DRV_R_PWR	1 A
43	S_EN1	1 A
44	S_EN2	1 A
45	R_EN	100 mA
46	G_EN	100 mA
47	B_EN	100 mA
48	VSS_DRV_R	1 A

Again, these values are for peak currents. In a typical application, these signals will be driven at a relatively low average frequency, about 10 kHz. Assuming a FET gate capacitance of 2 nF and that the FETS are driven at 6 V, the magnitude of the DC current draw of these signals is approximately:

$$I = 2 \times C \times \text{delta}V \times f = 2(2 \text{ nF})(6 \text{ V})(10 \text{ kHz}) = 240 \mu\text{A} \quad (1)$$

For the power and ground signals, this number should be multiplied by the number of active FETs, giving a value around 1.25 mA.

In addition to these high current signals that are driven by the TPS99000S-Q1, the LED driver electronics will likely have other circuits which handle the high currents required by the LEDs. These currents may be as high as 6 A and therefore will also require special consideration by the layout engineer. As a guide for the PCB trace width requirements, the reader is referred to TI's Application Note ([SLUA366](#)). The PCB trace widths used in TI's design were:

Table 10-3. PCB Trace Widths

SIGNAL GROUP	PCB TRACE WIDTH
DMD Regulator	10 mils
Gate Drivers	5 mils
LED Driver	200 mils minimum, but maximize where possible to decrease power losses

10.1.2 Sensitive Analog Signals

The following signals are analog inputs to TPS99000S-Q1. Most of these analog inputs are DC levels and are somewhat insensitive to noise, but others are part of the real-time color control algorithm of the TPS99000S-Q1 and therefore must be kept immune from noise injection from other signals. The list of analog input pins is as follows:

Table 10-4. TPS99000S-Q1 Analog Input Pins

PIN	NAME	SIGNAL TYPE
70	TIA_PD2	Real-time
73	TIA_PD1	Real-time
82	LS_SENSE_N	Real-time
83	LS_SENSE_P	Real-time
85	ADC_IN1	Real-time
86	ADC_IN2	DC
88	ADC_IN3	DC
90	ADC_IN4	DC
92	ADC_IN5	DC
93	ADC_IN6	DC
94	ADC_IN7	DC
96	V3P3V	DC
97	V1P8V	DC
98	V1P1V	DC

In particular, the photodiode inputs TIA_PD1 and TIA_PD2 are especially sensitive to noise as they are inputs to very high gain amplifiers. It is recommended to shield these signals from noise with a ground trace next to the signal.

10.1.3 High Speed Digital Signals

The TPS99000S-Q1 has three serial interfaces that are used to transmit data into and out of the device. All these of these interfaces have a maximum clock speed of 30 MHz. In order to help prevent against high levels of EMI emissions, these signals should be laid out with impedance matched, low inductance traces. In particular, the three clocks for these interfaces should be low inductance, and if a cable or a connector is used, the clock signal should be adjacent to the ground signal return.

Table 10-5. SPI1 Interface from DLPC230S-Q1 to TPS99000S-Q1

PIN	NAME	FUNCTION
27	SPI1_CLK	Clock (30 MHz)

Table 10-5. SPI1 Interface from DLPC230S-Q1 to TPS99000S-Q1 (continued)

PIN	NAME	FUNCTION
28	SPI1_SS_Z	Slave Select
29	SPI1_DOUT	Data
30	SPI1_DIN	Data

Table 10-6. SPI2 Interface from Customer MCU to TPS99000S-Q1

PIN	NAME	FUNCTION
31	SPI2_DIN	Data
32	SPI2_DOUT	Data
33	SPI2_SS_Z	Slave Select
34	SPI2_CLK	Clock (Up to 30 MHz)

Table 10-7. ADC3 Interface from DLPC230S-Q1 to TPS99000S-Q1

PIN	NAME	FUNCTION
4	ADC_MISO	Data
5	ADC_MOSI	Data
17	SEQ_CLK	Clock (30 MHz)

To avoid crosstalk, a PCB trace spacing requirement is suggested, such as the “3 W rule” which specifies that if the trace width is 5 mils, then traces should be spaced out at least 15 mils from center to center. On TI’s PCB design, the typical trace spacing was 20 mils.

As explained in the [Section 7.3.1.4](#) section, the COMPOUT signal indicates to the DLPC230S-Q1 that the discontinuous mode light pulses have been completed. It is critical that this signal has a fast response time in order to create small light pulses. For this reason, it is recommended that this signal has a limited trace capacitance, as mentioned in [Table 10-8](#).

Table 10-8. Trace Capacitance

PIN	NAME	PARAMETER	TYP	MAX	UNIT
12	COMPOUT	Trace capacitance	20	50	pF

10.1.4 High Power Current Loops

Due to the architecture of switched mode power supplies used to power the LED driver, there exist several current loops which can create interference. The best way to mitigate the effects of these loops is to minimize the area. Since the location of these loops is dependent on the LED drive architecture, the reader is referred to the data sheets of those parts for specific layout recommendation guidelines.

However, the TPS99000S-Q1 does add an additional current loop which is specific to how it enables the LEDs in low brightness conditions. When operating the TPS99000S-Q1 in discrete pulsed mode to achieve low light levels of LEDs, current flows through a shunt FET in the LED driver, creating a current loop which can inject noise into other circuits. The current loop is shown in [Figure 10-1](#).

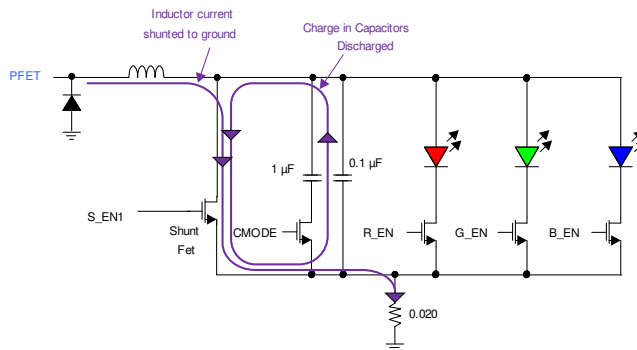

Figure 10-1. Discontinuous Mode Current Loop

Here, the net LED_COMMON_ANODE is at the forward voltage of the LED when it is conducting current, and LOW_SIDE_SENSE is at near ground potential. When forming pulses in discrete pulsed mode, the S_EN1 FET redirects the current from the LED, causing it to turn off quickly. This has the added effect of discharging the 1 µF capacitor, creating a brief, high current loop consisting of the S_EN1 FET, the C-MODE FET, and the 1 µF capacitor. There is also a secondary loop created by the S_EN1 FET and the 0.1 µF capacitor. This set of components should be placed in a way to keep these loops small. One such possible placement is shown in Figure 10-2.

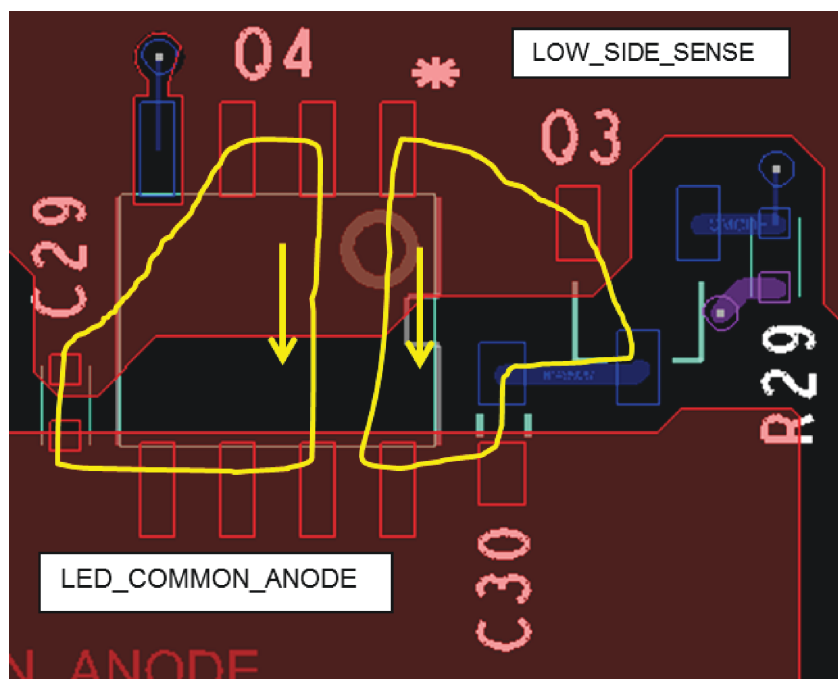

Figure 10-2. High Power Layout

10.1.5 Kelvin Sensing Connections

There are many places in the system design where the current through a signal path is measured by use of a sense resistor in series with the signal path. In these cases, the resistor should be connected by use of a “Kelvin” connection, or a “Force-Sense” connection. This means that two connections are made to the resistor that carry the high level of current, and two connections are made separately to measure the voltage across the resistor. This prevents the sense lines from being affected by the extra resistance of the copper traces, and makes the measurement more accurate. An example of the “Force-Sense” connection is shown in Figure 10-3.

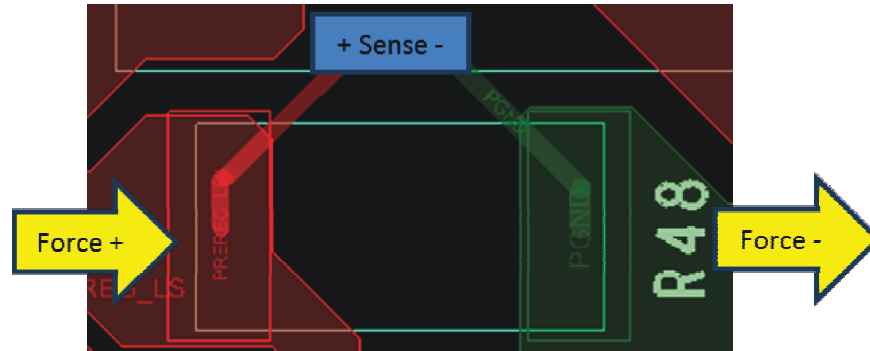

Figure 10-3. Kelvin Sensing Layout

The TPS99000S-Q1 uses a sense resistor to measure the current delivered to the LEDs. These differential sense lines are the inputs to the part LS_SENSE_P and LS_SENSE_N. It is important to notice that although LS_SENSE_N may be electrically connected to ground by the netlist, this signal must be routed as a separate trace to prevent it from being affected by changes in the ground plane.

10.1.6 Ground Separation

Separated ground planes are good for isolating noise from different parts of the circuit to other. However, when designing with separate ground planes, one must be careful of how the signals are routed to avoid large inductive loops. If separate ground planes are used, TI recommends the following ground connections to the TPS99000S-Q1. In addition, the grounds should be connected electrically by a via or 0 Ω resistor. If a unified ground plane is used, the following can be used as a guideline for which groups of signals should be routed apart from other signals.

Table 10-9. TPS99000S-Q1 Ground Separation

PIN	NAME	GROUND
13, 35	VSS_IO	Digital
24	DVSS	Digital
25, 60, 75, 99	PBKG	Analog
48	VSS_DRVR	Power
53	DRST_PGND	Power
56	VSS_DRST	Power
66	GND_LDO	Analog
71, 72	VSS_TIA	Analog
78, 100	AVSS	Analog
81, 84, 87, 89, 91	VSSL_ADC	Analog
Thermal Pad	DAP	Analog

11 Device and Documentation Support

11.1 Device Support

11.1.1 Third-Party Products Disclaimer

TI'S PUBLICATION OF INFORMATION REGARDING THIRD-PARTY PRODUCTS OR SERVICES DOES NOT CONSTITUTE AN ENDORSEMENT REGARDING THE SUITABILITY OF SUCH PRODUCTS OR SERVICES OR A WARRANTY, REPRESENTATION OR ENDORSEMENT OF SUCH PRODUCTS OR SERVICES, EITHER ALONE OR IN COMBINATION WITH ANY TI PRODUCT OR SERVICE.

11.2 Receiving Notification of Documentation Updates

To receive notification of documentation updates, navigate to the device product folder on ti.com. Click on *Subscribe to updates* to register and receive a weekly digest of any product information that has changed. For change details, review the revision history included in any revised document.

11.3 Support Resources

[TI E2E™ support forums](#) are an engineer's go-to source for fast, verified answers and design help — straight from the experts. Search existing answers or ask your own question to get the quick design help you need.

Linked content is provided "AS IS" by the respective contributors. They do not constitute TI specifications and do not necessarily reflect TI's views; see TI's [Terms of Use](#).

11.4 Trademarks

TI E2E™ is a trademark of Texas Instruments.

DLP® is a registered trademark of Texas Instruments.

All trademarks are the property of their respective owners.

11.5 Electrostatic Discharge Caution



This integrated circuit can be damaged by ESD. Texas Instruments recommends that all integrated circuits be handled with appropriate precautions. Failure to observe proper handling and installation procedures can cause damage.

ESD damage can range from subtle performance degradation to complete device failure. Precision integrated circuits may be more susceptible to damage because very small parametric changes could cause the device not to meet its published specifications.

11.6 Glossary

[TI Glossary](#) This glossary lists and explains terms, acronyms, and definitions.

12 Mechanical, Packaging, and Orderable Information

The following pages include mechanical, packaging, and orderable information. This information is the most current data available for the designated devices. This data is subject to change without notice and revision of this document. For browser-based versions of this data sheet, refer to the left-hand navigation.

PACKAGING INFORMATION

Orderable Device	Status (1)	Package Type	Package Drawing	Pins	Package Qty	Eco Plan (2)	Lead finish/ Ball material (6)	MSL Peak Temp (3)	Op Temp (°C)	Device Marking (4/5)	Samples
TPS990STPZPQ1	ACTIVE	HTQFP	PZP	100	90	RoHS & Green	NIPDAU	Level-3-260C-168 HR	-40 to 105	TPS990STPZP	Samples
TPS990STPZPRQ1	ACTIVE	HTQFP	PZP	100	1000	RoHS & Green	NIPDAU	Level-3-260C-168 HR	-40 to 105	TPS990STPZP	Samples

(1) The marketing status values are defined as follows:

ACTIVE: Product device recommended for new designs.

LIFEBUY: TI has announced that the device will be discontinued, and a lifetime-buy period is in effect.

NRND: Not recommended for new designs. Device is in production to support existing customers, but TI does not recommend using this part in a new design.

PREVIEW: Device has been announced but is not in production. Samples may or may not be available.

OBSOLETE: TI has discontinued the production of the device.

(2) **RoHS:** TI defines "RoHS" to mean semiconductor products that are compliant with the current EU RoHS requirements for all 10 RoHS substances, including the requirement that RoHS substance do not exceed 0.1% by weight in homogeneous materials. Where designed to be soldered at high temperatures, "RoHS" products are suitable for use in specified lead-free processes. TI may reference these types of products as "Pb-Free".

RoHS Exempt: TI defines "RoHS Exempt" to mean products that contain lead but are compliant with EU RoHS pursuant to a specific EU RoHS exemption.

Green: TI defines "Green" to mean the content of Chlorine (Cl) and Bromine (Br) based flame retardants meet JS709B low halogen requirements of <=1000ppm threshold. Antimony trioxide based flame retardants must also meet the <=1000ppm threshold requirement.

(3) MSL, Peak Temp. - The Moisture Sensitivity Level rating according to the JEDEC industry standard classifications, and peak solder temperature.

(4) There may be additional marking, which relates to the logo, the lot trace code information, or the environmental category on the device.

(5) Multiple Device Markings will be inside parentheses. Only one Device Marking contained in parentheses and separated by a "~" will appear on a device. If a line is indented then it is a continuation of the previous line and the two combined represent the entire Device Marking for that device.

(6) Lead finish/Ball material - Orderable Devices may have multiple material finish options. Finish options are separated by a vertical ruled line. Lead finish/Ball material values may wrap to two lines if the finish value exceeds the maximum column width.

Important Information and Disclaimer:The information provided on this page represents TI's knowledge and belief as of the date that it is provided. TI bases its knowledge and belief on information provided by third parties, and makes no representation or warranty as to the accuracy of such information. Efforts are underway to better integrate information from third parties. TI has taken and continues to take reasonable steps to provide representative and accurate information but may not have conducted destructive testing or chemical analysis on incoming materials and chemicals. TI and TI suppliers consider certain information to be proprietary, and thus CAS numbers and other limited information may not be available for release.

In no event shall TI's liability arising out of such information exceed the total purchase price of the TI part(s) at issue in this document sold by TI to Customer on an annual basis.

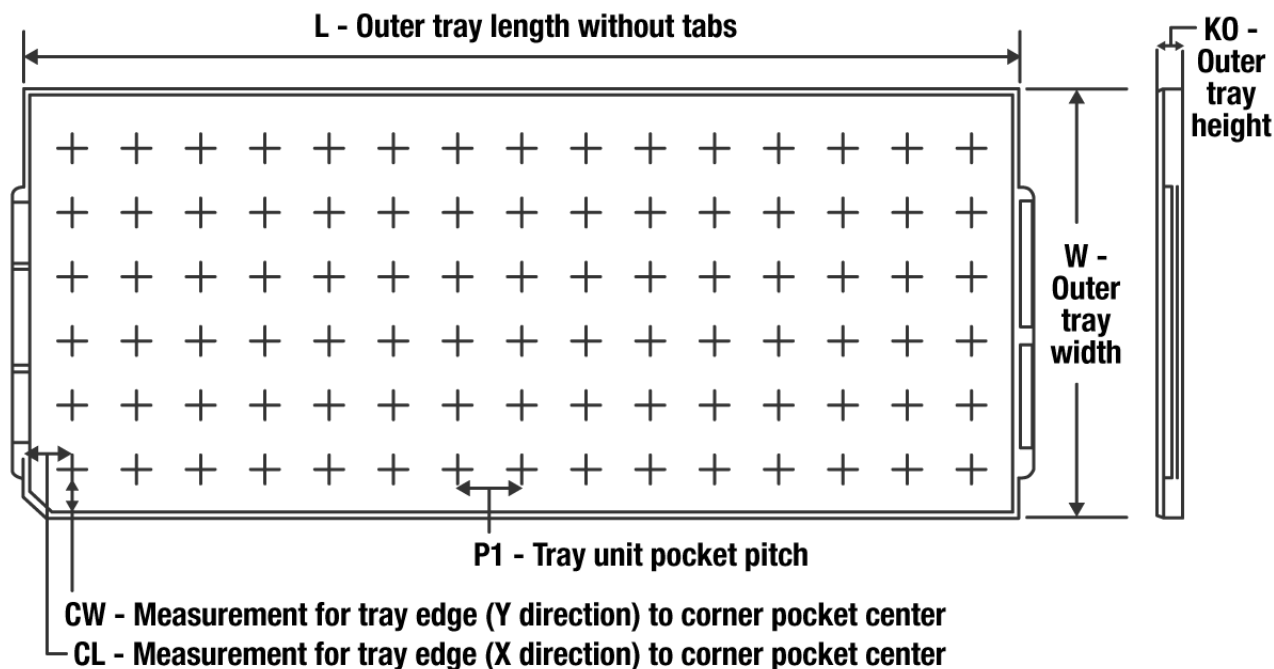
TRAY

Chamfer on Tray corner indicates Pin 1 orientation of packed units.

*All dimensions are nominal

Device	Package Name	Package Type	Pins	SPQ	Unit array matrix	Max temperature (°C)	L (mm)	W (mm)	K0 (µm)	P1 (mm)	CL (mm)	CW (mm)
TPS990STPZPQ1	PZP	HTQFP	100	90	6 X 15	150	315	135.9	7620	15.4	20.3	21

GENERIC PACKAGE VIEW

PZP 100

PowerPAD™ TQFP - 1.2 mm max height

14 x 14 mm Pkg Body, 0.5 mm pitch
16 x 16 mm Pkg Area

PLASTIC QUAD FLATPACK

This image is a representation of the package family, actual package may vary.
Refer to the product data sheet for package details.

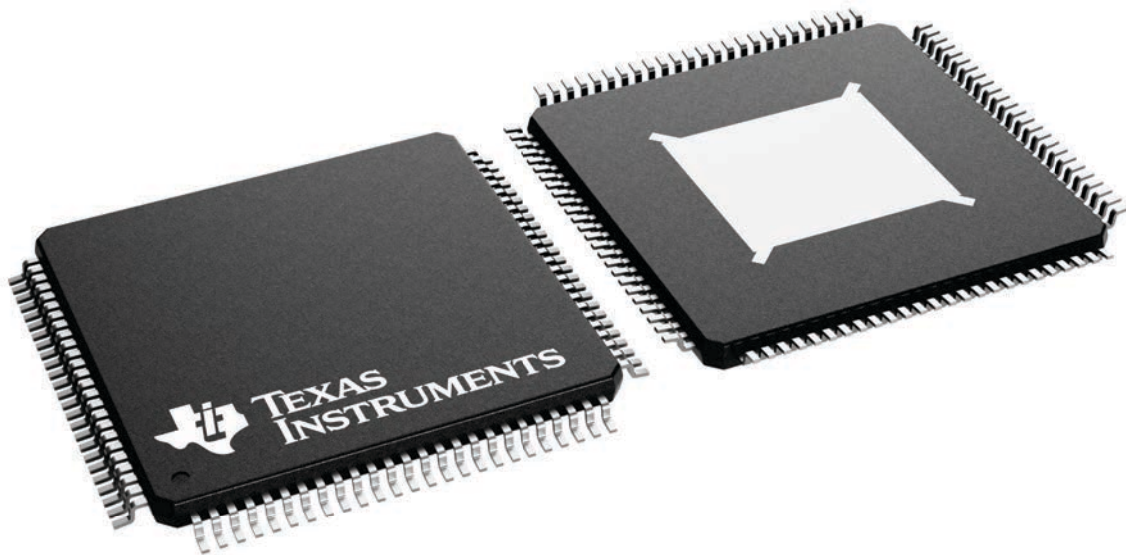

4224739/B

PZP0100K

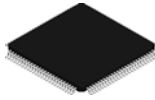

PACKAGE OUTLINE

PowerPAD™ TQFP - 1.2 mm max height

PLASTIC QUAD FLATPACK

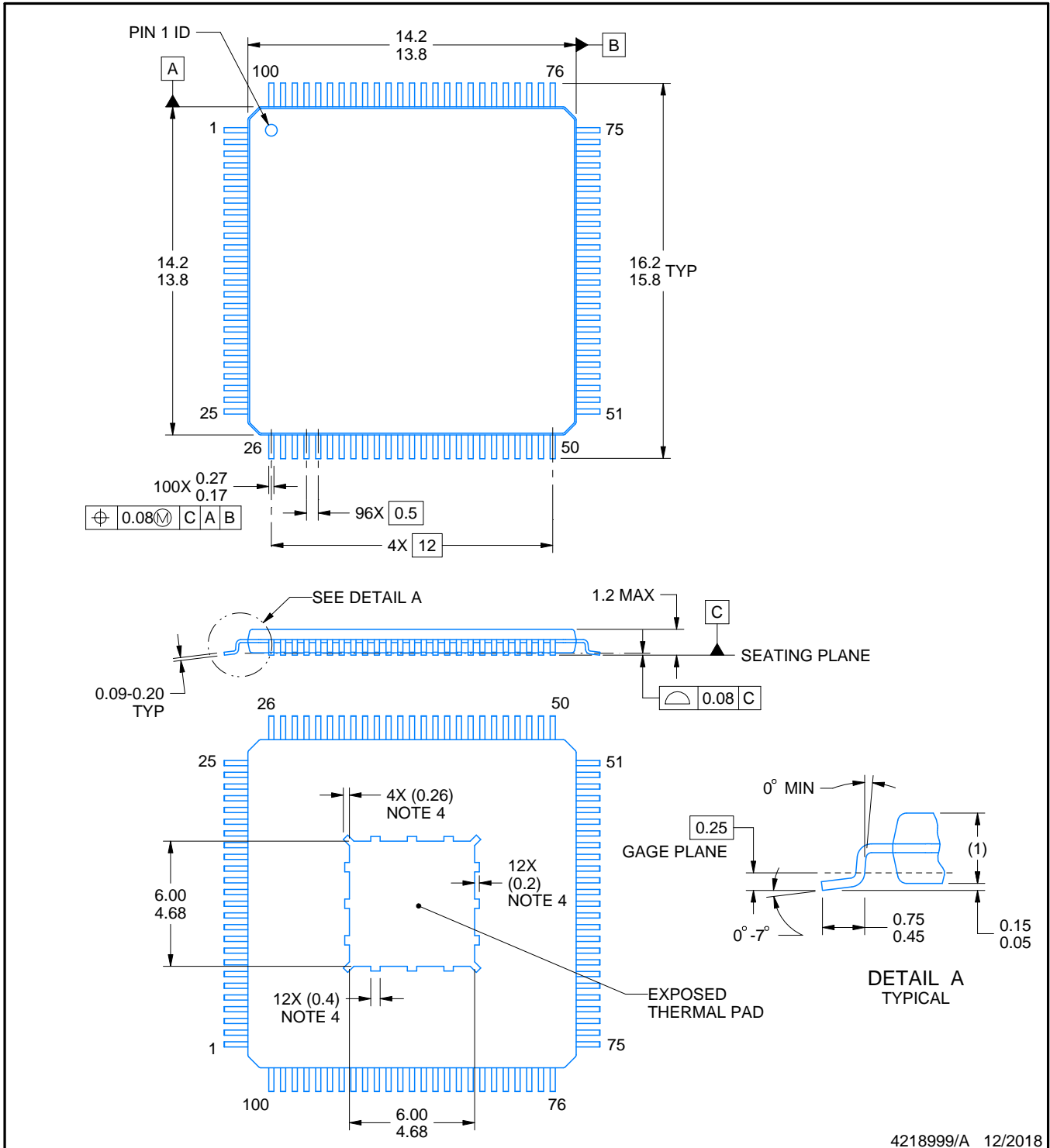

PowerPAD is a trademark of Texas Instruments.

NOTES:

1. All linear dimensions are in millimeters. Any dimensions in parenthesis are for reference only. Dimensioning and tolerancing per ASME Y14.5M.
2. This drawing is subject to change without notice.
3. Reference JEDEC registration MS-026, variation ACD.
4. Strap features may not be present,

EXAMPLE BOARD LAYOUT

PZP0100K

PowerPAD™ TQFP - 1.2 mm max height

PLASTIC QUAD FLATPACK

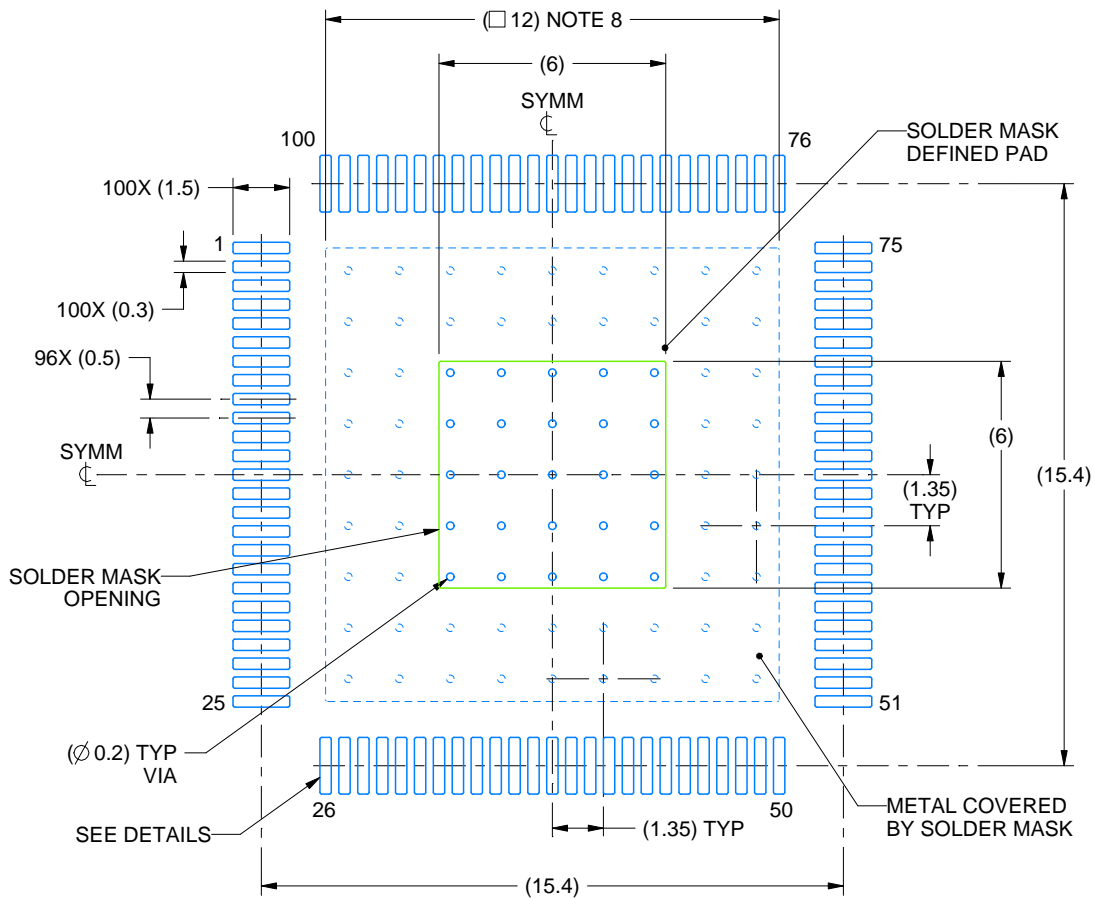

LAND PATTERN EXAMPLE
EXPOSED METAL SHOWN
SCALE:5X

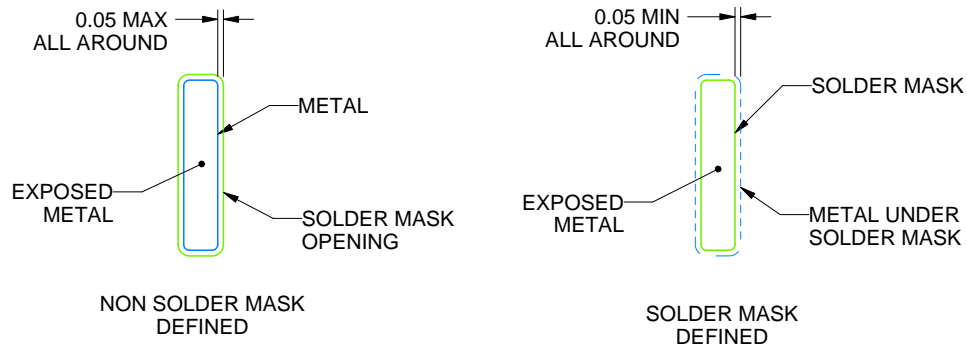

SOLDER MASK DETAILS

4218999/A 12/2018

NOTES: (continued)

5. Publication IPC-7351 may have alternate designs.
6. Solder mask tolerances between and around signal pads can vary based on board fabrication site.
7. This package is designed to be soldered to a thermal pad on the board. For more information, see Texas Instruments literature numbers SLMA002 (www.ti.com/lit/slma002) and SLMA004 (www.ti.com/lit/slma004).
8. Size of metal pad may vary due to creepage requirement.

EXAMPLE STENCIL DESIGN

PZP0100K

PowerPAD™ TQFP - 1.2 mm max height

PLASTIC QUAD FLATPACK

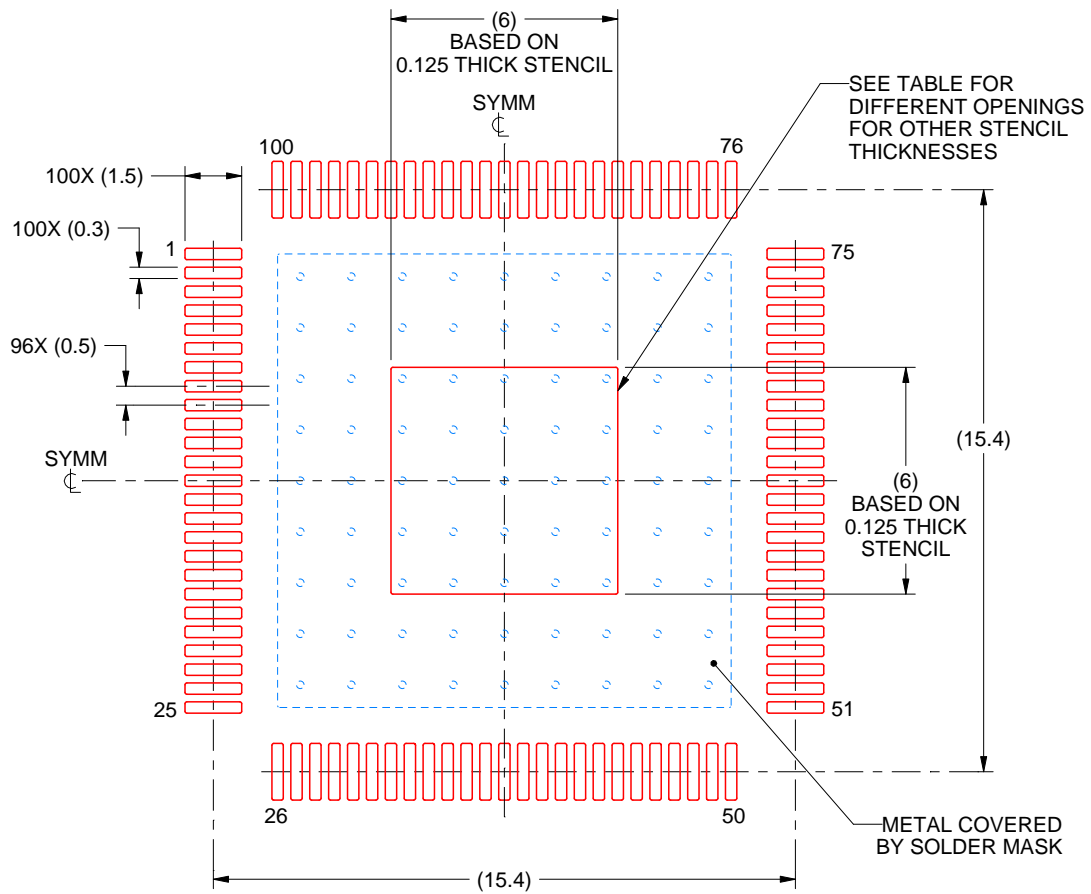

SOLDER PASTE EXAMPLE
 EXPOSED PAD
 100% PRINTED SOLDER COVERAGE BY AREA
 SCALE:5X

STENCIL THICKNESS	SOLDER STENCIL OPENING
0.1	6.71 X 6.71
0.125	6 X 6 (SHOWN)
0.150	5.48 X 5.48
0.175	5.07 X 5.07

4218999/A 12/2018

NOTES: (continued)

- 9. Laser cutting apertures with trapezoidal walls and rounded corners may offer better paste release. IPC-7525 may have alternate design recommendations.
- 10. Board assembly site may have different recommendations for stencil design.

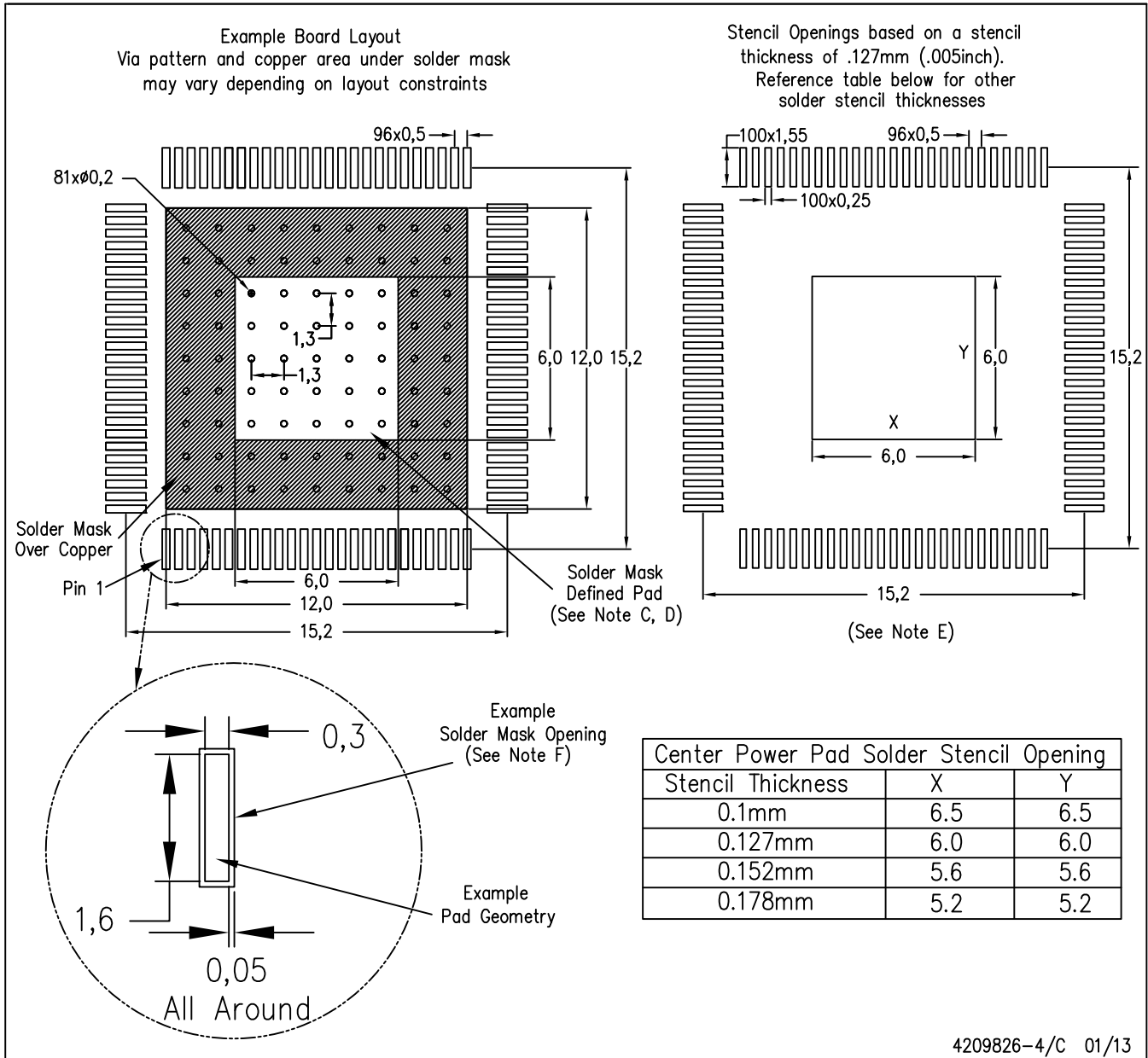

- NOTES:
- A. All linear dimensions are in millimeters.
 - B. This drawing is subject to change without notice.
 - C. Customers should place a note on the circuit board fabrication drawing not to alter the center solder mask defined pad.
 - D. This package is designed to be soldered to a thermal pad on the board. Refer to Technical Brief, PowerPAD Thermally Enhanced Package, Texas Instruments Literature No. SLMA002, SLMA004, and also the Product Data Sheets for specific thermal information, via requirements, and recommended board layout. These documents are available at www.ti.com <<http://www.ti.com>>. Publication IPC-7351 is recommended for alternate designs.
 - E. Laser cutting apertures with trapezoidal walls and also rounding corners will offer better paste release. Customers should contact their board assembly site for stencil design recommendations. Example stencil design based on a 50% volumetric metal load solder paste. Refer to IPC-7525 for other stencil recommendations.
 - F. Customers should contact their board fabrication site for solder mask tolerances between and around signal pads.

PowerPAD is a trademark of Texas Instruments.

IMPORTANT NOTICE AND DISCLAIMER

TI PROVIDES TECHNICAL AND RELIABILITY DATA (INCLUDING DATA SHEETS), DESIGN RESOURCES (INCLUDING REFERENCE DESIGNS), APPLICATION OR OTHER DESIGN ADVICE, WEB TOOLS, SAFETY INFORMATION, AND OTHER RESOURCES "AS IS" AND WITH ALL FAULTS, AND DISCLAIMS ALL WARRANTIES, EXPRESS AND IMPLIED, INCLUDING WITHOUT LIMITATION ANY IMPLIED WARRANTIES OF MERCHANTABILITY, FITNESS FOR A PARTICULAR PURPOSE OR NON-INFRINGEMENT OF THIRD PARTY INTELLECTUAL PROPERTY RIGHTS.

These resources are intended for skilled developers designing with TI products. You are solely responsible for (1) selecting the appropriate TI products for your application, (2) designing, validating and testing your application, and (3) ensuring your application meets applicable standards, and any other safety, security, regulatory or other requirements.

These resources are subject to change without notice. TI grants you permission to use these resources only for development of an application that uses the TI products described in the resource. Other reproduction and display of these resources is prohibited. No license is granted to any other TI intellectual property right or to any third party intellectual property right. TI disclaims responsibility for, and you will fully indemnify TI and its representatives against, any claims, damages, costs, losses, and liabilities arising out of your use of these resources.

TI's products are provided subject to [TI's Terms of Sale](#) or other applicable terms available either on [ti.com](https://www.ti.com) or provided in conjunction with such TI products. TI's provision of these resources does not expand or otherwise alter TI's applicable warranties or warranty disclaimers for TI products.

TI objects to and rejects any additional or different terms you may have proposed.

Mailing Address: Texas Instruments, Post Office Box 655303, Dallas, Texas 75265
Copyright © 2023, Texas Instruments Incorporated

Looking for pricing, stock, or lifecycle information?

Click below to explore more details on WIN SOURCE:

 [View TPS990STPZPRQ1](#) on WIN SOURCE

 [Texas Instruments](#) Information

Optimize Your Supply Chain with WIN SOURCE Solutions

-  Global Sourcing Solution
-  Obsolete Management
-  Cost Control Management
-  Shortage Management
-  Alternative Solution
-  Excess Inventory Management