



THE DATASHEET OF BUL1102E



Features

- High voltage capability
- Very high switching speed

Applications

Four lamp electronic ballast for:

- 120 V mains in push-pull configuration
- 277 V mains in half bridge current feed configuration

Description

This is a high voltage fast switching NPN power transistor manufactured in multi epitaxial planar technology. It uses a cellular emitter structure with planar edge termination to enhance switching speeds while maintaining a wide RBSOA.

Thanks to an increased intermediate layer, it has an intrinsic ruggedness which enables the transistor to withstand a high collector current level during breakdown condition, without using the Transil™ protection usually necessary in typical converters for lamp ballast.

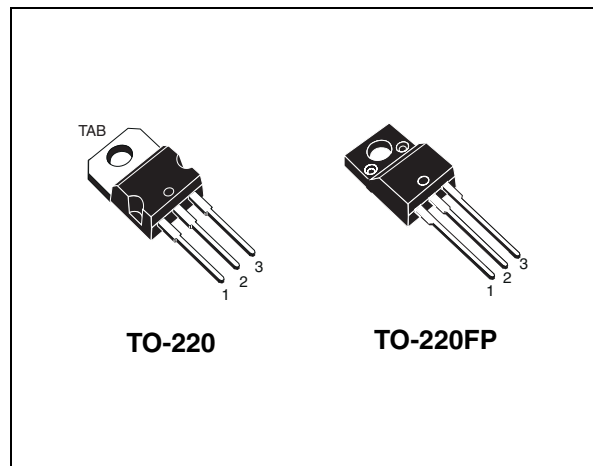

Figure 1. Internal schematic diagram

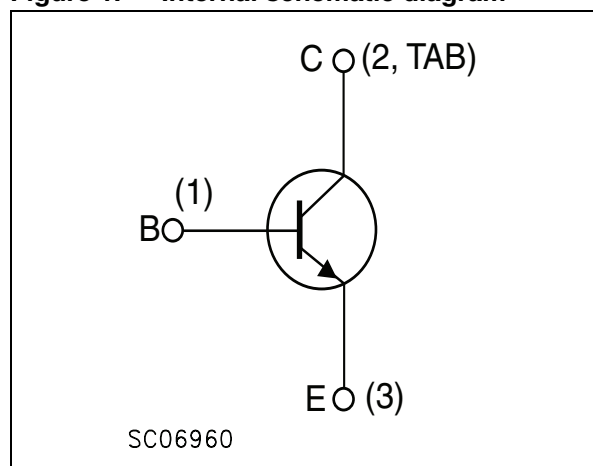

Table 1. Device summary

Order codes	Marking	Package	Packaging
BUL1102E	BUL1102E	TO-220	Tube
BUL1102EFP	BUL1102EFP	TO-220FP	Tube

1 Absolute maximum ratings

Table 2. Absolute maximum ratings

Symbol	Parameter	Value	Unit
V_{CES}	Collector-emitter voltage ($V_{BE} = 0$)	1100	V
V_{CEO}	Collector-emitter voltage ($I_B = 0$)	450	V
V_{EBO}	Emitter-base voltage ($I_C = 0$)	12	V
I_C	Collector current	4	A
I_{CM}	Collector peak current ($t_P < 5$ ms)	8	A
I_B	Base current	2	A
I_{BM}	Base peak current ($t_P < 5$ ms)	4	A
P_{TOT}	BUL1102E total dissipation at $T_C = 25^\circ\text{C}$	70	W
	BUL1102EFP total dissipation at $T_C = 25^\circ\text{C}$	30	
V_{ISO}	BUL1102EFP insulation withstand voltage (RMS) from all three leads to external heatsink	1500	V
T_{STG}	Storage temperature	-65 to 150	$^\circ\text{C}$
T_J	Max. operating junction temperature	150	$^\circ\text{C}$

Table 3. Thermal data

Symbol	Parameter	Value	Unit
R_{thJC}	BUL1203E thermal resistance junction-case	1.8	$^\circ\text{C}/\text{W}$
	BUL1203EFP thermal resistance junction-case	4.2	$^\circ\text{C}/\text{W}$

2 Electrical characteristics

($T_J = 25\text{ °C}$; unless otherwise specified)

Table 4. Electrical characteristics

Symbol	Parameter	Test conditions	Min.	Typ.	Max.	Unit
I_{CES}	Collector cut-off current ($V_{BE} = 0$)	$V_{CE} = 1100\text{ V}$			100	μA
I_{EBO}	Emitter cut-off current ($I_C = 0$)	$V_{EB} = 12\text{ V}$			1	mA
$V_{CEO(sus)}^{(1)}$	Collector-emitter sustaining voltage ($I_B = 0$)	$I_C = 100\text{ mA}$	450			V
$V_{CE(sat)}^{(1)}$	Collector-emitter saturation voltage	$I_C = 2\text{ A}$ $I_B = 400\text{ mA}$			1.5	V
$V_{BE(sat)}^{(1)}$	Base-emitter saturation voltage	$I_C = 2\text{ A}$ $I_B = 400\text{ mA}$			1.5	V
$h_{FE}^{(1)}$	DC current gain	$I_C = 250\text{ mA}$ $V_{CE} = 5\text{ V}$ $I_C = 2\text{ A}$, $V_{CE} = 5\text{ V}$ for BUL1102E $I_C = 2\text{ A}$ $V_{CE} = 5\text{ V}$ for BUL1102EFP	35 12 12		70 20 23	
t_s t_f	Resistive load Storage time Fall time	$I_C = 2.5\text{ A}$ $V_{CC} = 250\text{ V}$ $I_{B1} = 0.5\text{ A}$ $I_{B2} = 1\text{ A}$ $T_P = 30\text{ }\mu\text{s}$ (see Figure 14)			2.5 300	μs ns
E_{ar}	Avalanche energy	$L = 2\text{ mH}$ $C = 1.8\text{ nF}$ $I_{BR} \leq 2.5\text{ A}$ $25\text{ °C} < T_C < 125\text{ °C}$ (see Figure 12)	6			mJ

1. Pulse test: pulse duration $\leq 300\text{ }\mu\text{s}$, duty cycle $\leq 2\%$.

2.1 Typical characteristics (curves)

Figure 2. BUL1102E safe operating area

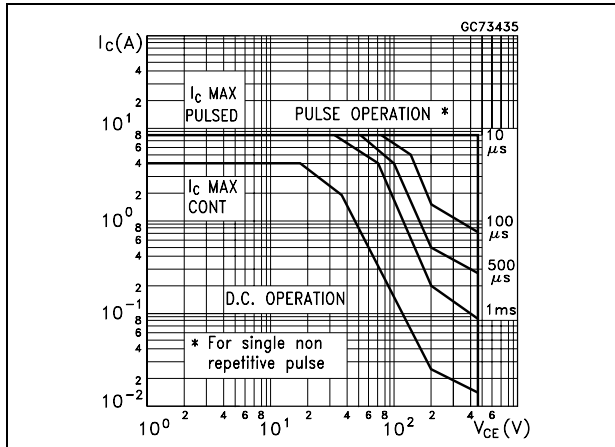

Figure 3. BUL1102EFP safe operating area

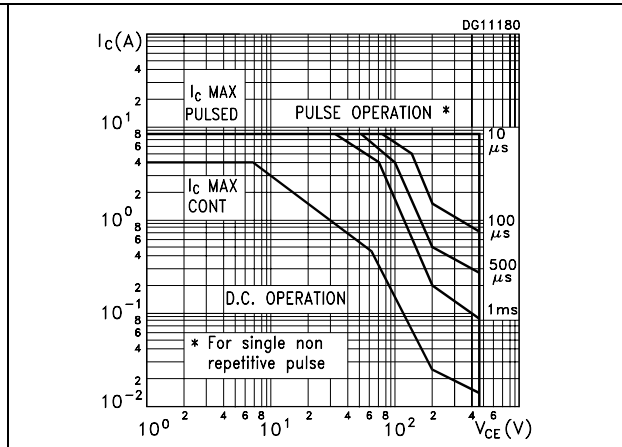

Figure 4. Derating curve

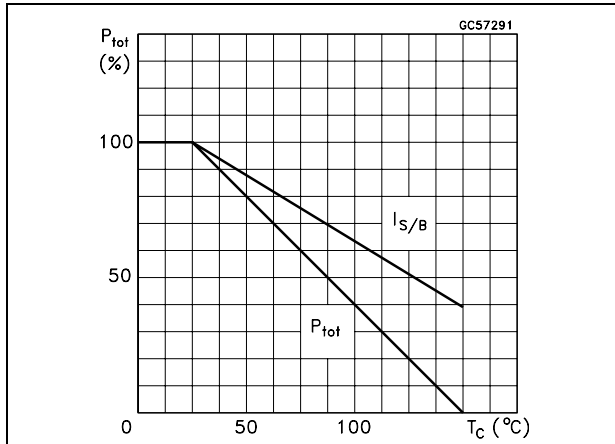

Figure 5. DC current gain (Vce = 1 V)

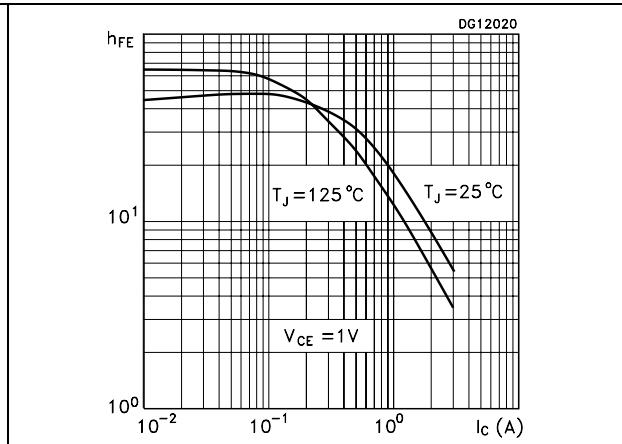

Figure 6. DC current gain (Vce = 5 V)

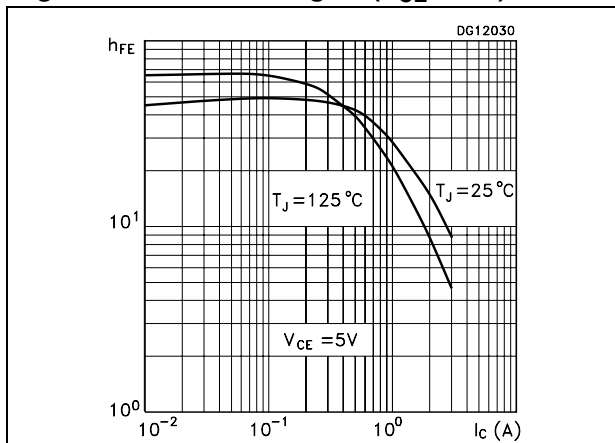

Figure 7. Collector emitter saturation voltage

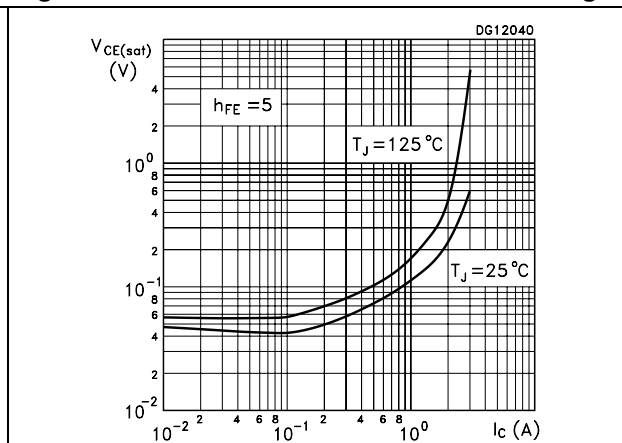

Figure 8. Base emitter saturation voltage

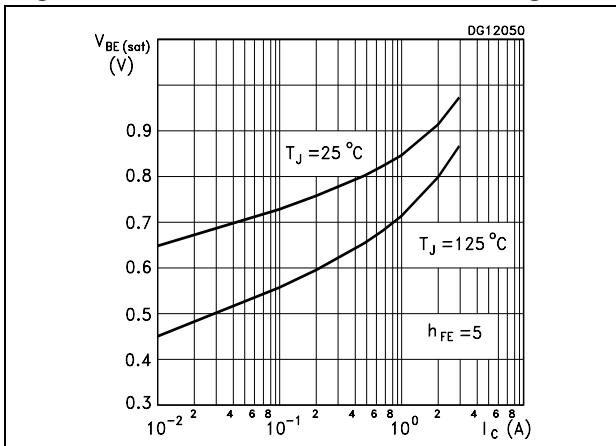

Figure 9. Resistive load switching times

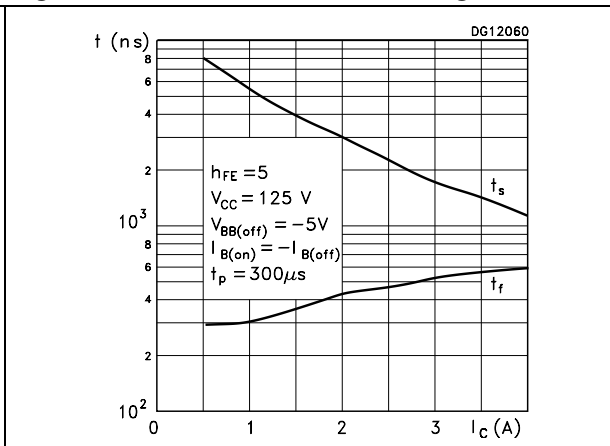

Figure 10. Inductive load switching times

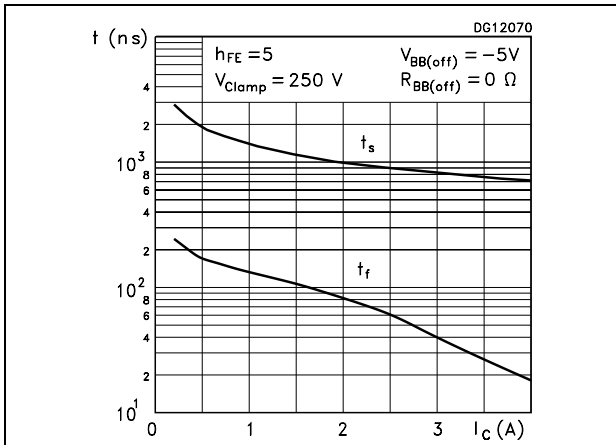

Figure 11. Reverse biased SOA

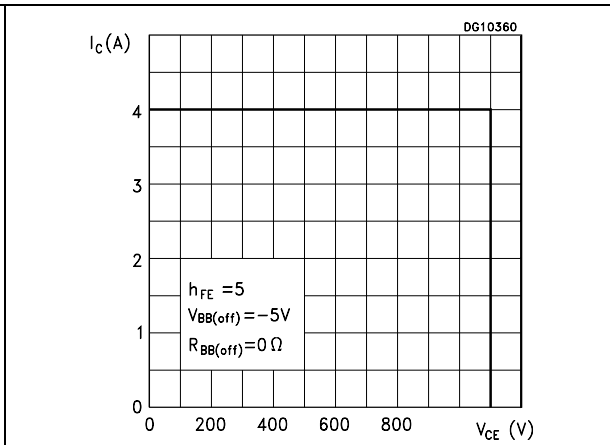

Figure 12. Energy rating test circuit

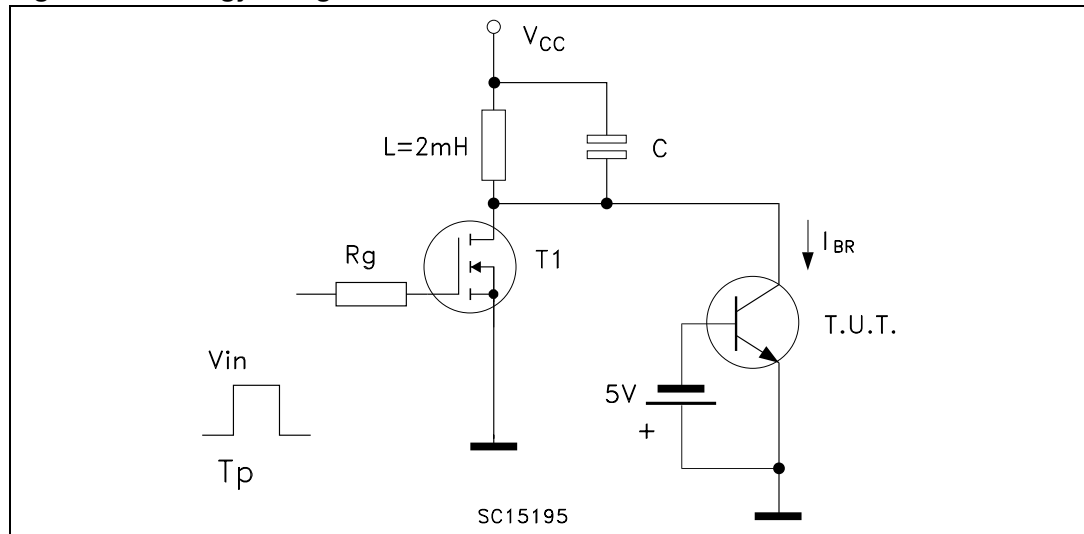

Figure 13. Inductive load switching test circuit

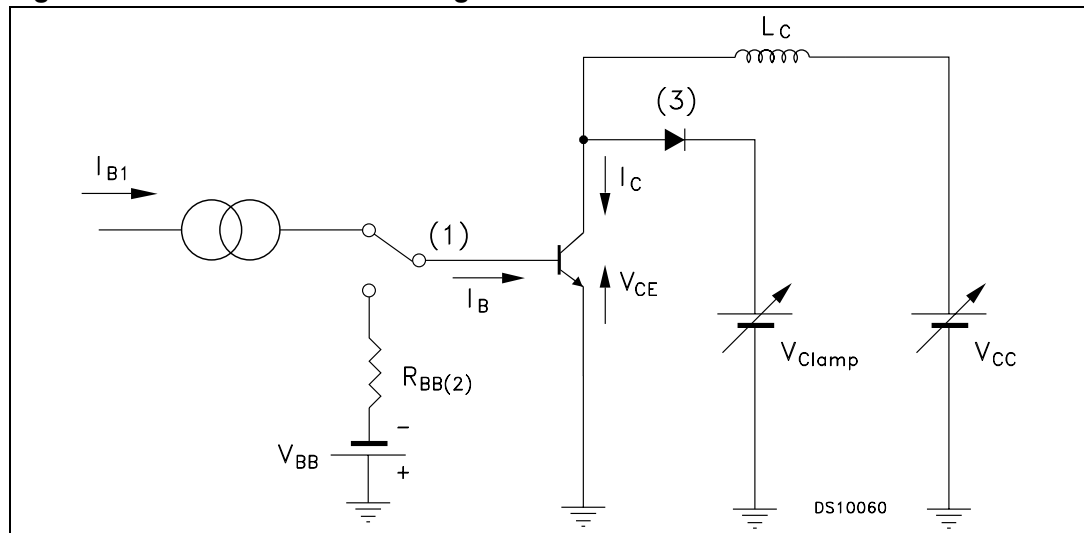
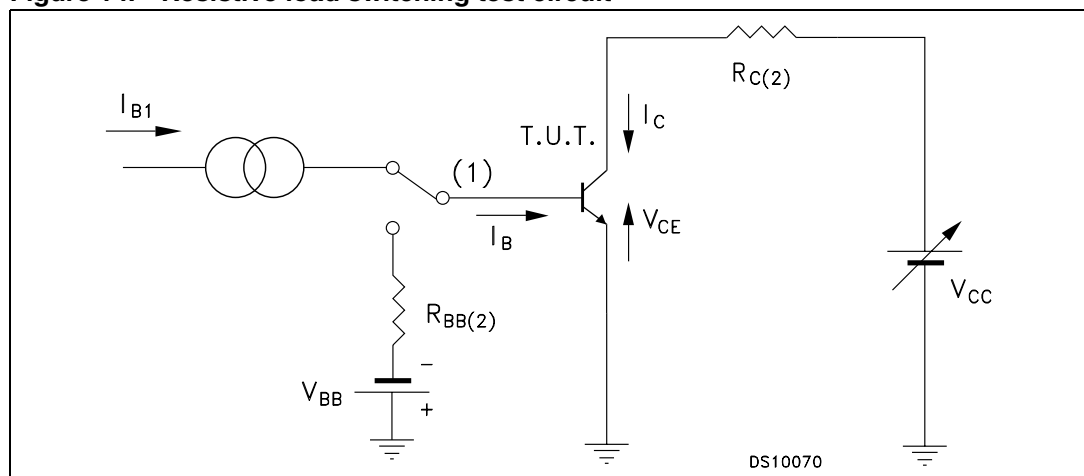

Figure 14. Resistive load switching test circuit



3 Package mechanical data

In order to meet environmental requirements, ST offers these devices in different grades of ECOPACK[®] packages, depending on their level of environmental compliance. ECOPACK[®] specifications, grade definitions and product status are available at: www.st.com. ECOPACK[®] is an ST trademark.

Table 5. TO-220 type A mechanical data

Dim.	mm		
	Min.	Typ.	Max.
A	4.40		4.60
b	0.61		0.88
b1	1.14		1.70
c	0.48		0.70
D	15.25		15.75
D1		1.27	
E	10		10.40
e	2.40		2.70
e1	4.95		5.15
F	1.23		1.32
H1	6.20		6.60
J1	2.40		2.72
L	13		14
L1	3.50		3.93
L20		16.40	
L30		28.90	
ØP	3.75		3.85
Q	2.65		2.95

Figure 15. TO-220 type A drawing

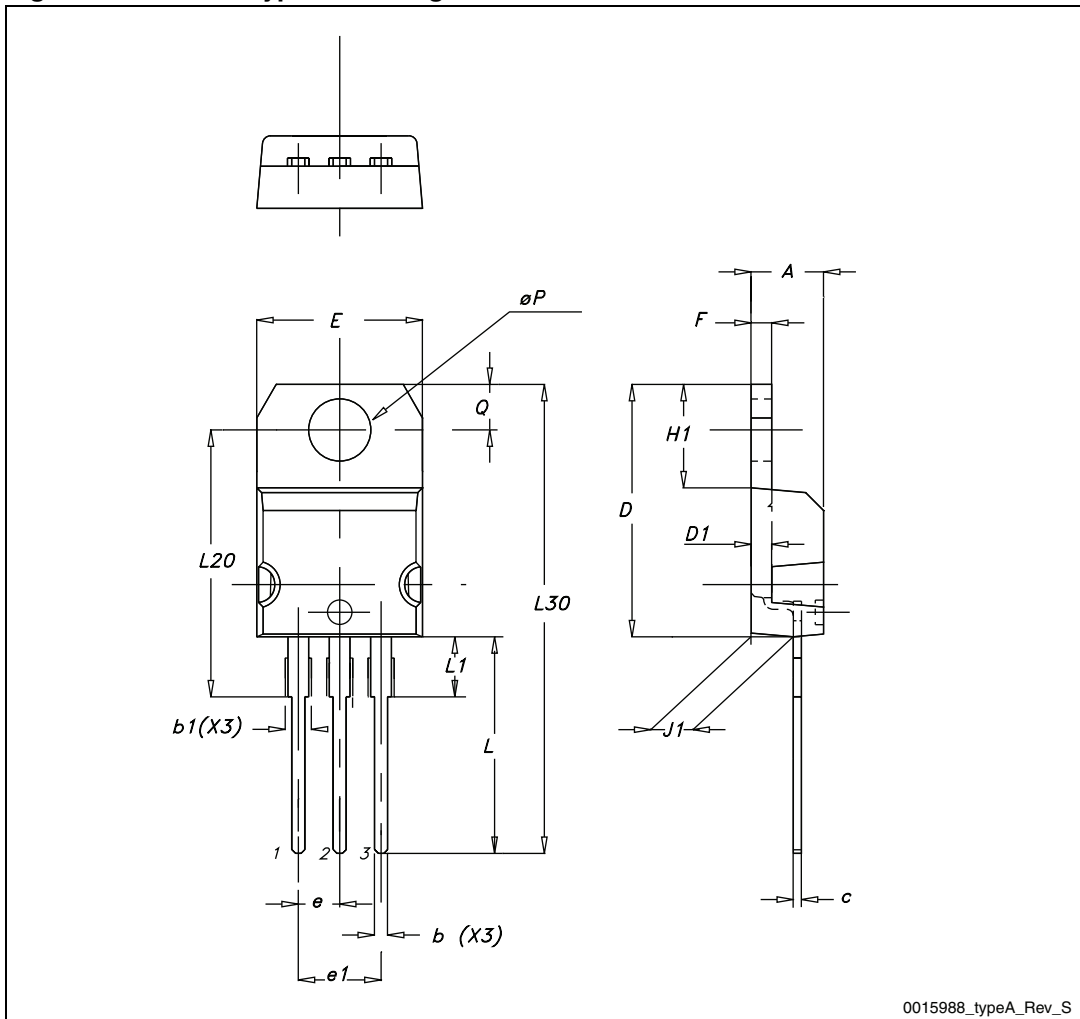
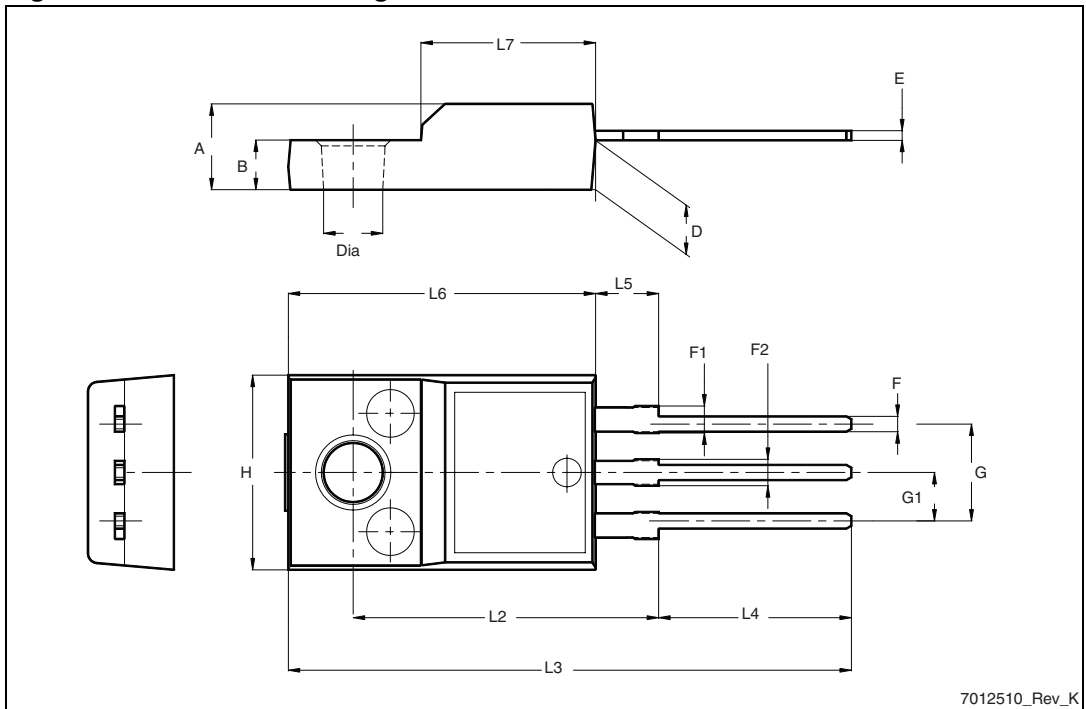

Table 6. TO-220FP mechanical data

Dim.	mm		
	Min.	Typ.	Max.
A	4.4		4.6
B	2.5		2.7
D	2.5		2.75
E	0.45		0.7
F	0.75		1
F1	1.15		1.70
F2	1.15		1.70
G	4.95		5.2
G1	2.4		2.7
H	10		10.4
L2		16	
L3	28.6		30.6
L4	9.8		10.6
L5	2.9		3.6
L6	15.9		16.4
L7	9		9.3
Dia	3		3.2

Figure 16. TO-220FP drawing



4 Revision history

Table 7. Document revision history

Date	Revision	Changes
17-Jan-2008	3	
24-Mar-2011	4	Inserted BUL1102EFP order code in TO-220FP package
15-Feb-2012	5	DC current gain values in Table 4 modified

Please Read Carefully:

Information in this document is provided solely in connection with ST products. STMicroelectronics NV and its subsidiaries ("ST") reserve the right to make changes, corrections, modifications or improvements, to this document, and the products and services described herein at any time, without notice.

All ST products are sold pursuant to ST's terms and conditions of sale.

Purchasers are solely responsible for the choice, selection and use of the ST products and services described herein, and ST assumes no liability whatsoever relating to the choice, selection or use of the ST products and services described herein.

No license, express or implied, by estoppel or otherwise, to any intellectual property rights is granted under this document. If any part of this document refers to any third party products or services it shall not be deemed a license grant by ST for the use of such third party products or services, or any intellectual property contained therein or considered as a warranty covering the use in any manner whatsoever of such third party products or services or any intellectual property contained therein.

UNLESS OTHERWISE SET FORTH IN ST'S TERMS AND CONDITIONS OF SALE ST DISCLAIMS ANY EXPRESS OR IMPLIED WARRANTY WITH RESPECT TO THE USE AND/OR SALE OF ST PRODUCTS INCLUDING WITHOUT LIMITATION IMPLIED WARRANTIES OF MERCHANTABILITY, FITNESS FOR A PARTICULAR PURPOSE (AND THEIR EQUIVALENTS UNDER THE LAWS OF ANY JURISDICTION), OR INFRINGEMENT OF ANY PATENT, COPYRIGHT OR OTHER INTELLECTUAL PROPERTY RIGHT.

UNLESS EXPRESSLY APPROVED IN WRITING BY TWO AUTHORIZED ST REPRESENTATIVES, ST PRODUCTS ARE NOT RECOMMENDED, AUTHORIZED OR WARRANTED FOR USE IN MILITARY, AIR CRAFT, SPACE, LIFE SAVING, OR LIFE SUSTAINING APPLICATIONS, NOR IN PRODUCTS OR SYSTEMS WHERE FAILURE OR MALFUNCTION MAY RESULT IN PERSONAL INJURY, DEATH, OR SEVERE PROPERTY OR ENVIRONMENTAL DAMAGE. ST PRODUCTS WHICH ARE NOT SPECIFIED AS "AUTOMOTIVE GRADE" MAY ONLY BE USED IN AUTOMOTIVE APPLICATIONS AT USER'S OWN RISK.

Resale of ST products with provisions different from the statements and/or technical features set forth in this document shall immediately void any warranty granted by ST for the ST product or service described herein and shall not create or extend in any manner whatsoever, any liability of ST.

ST and the ST logo are trademarks or registered trademarks of ST in various countries.

Information in this document supersedes and replaces all information previously supplied.

The ST logo is a registered trademark of STMicroelectronics. All other names are the property of their respective owners.

© 2012 STMicroelectronics - All rights reserved

STMicroelectronics group of companies



Australia - Belgium - Brazil - Canada - China - Czech Republic - Finland - France - Germany - Hong Kong - India - Israel - Italy - Japan - Malaysia - Malta - Morocco - Philippines - Singapore - Spain - Sweden - Switzerland - United Kingdom - United States of America

www.st.com



Looking for pricing, stock, or lifecycle information?

Click below to explore more details on WIN SOURCE:

-  [View BUL1102E on WIN SOURCE](#)
-  [STMicroelectronics Information](#)

Optimize Your Supply Chain with WIN SOURCE Solutions

-  Global Sourcing Solution
-  Obsolete Management
-  Cost Control Management
-  Shortage Management
-  Alternative Solution
-  Excess Inventory Management