



THE DATASHEET OF BULB128-1





BULB128-1

HIGH VOLTAGE FAST-SWITCHING NPN POWER TRANSISTOR

Ordering Code	Marking	Shipment
BULB128-1	BULB128	Tube

- STMicroelectronics PREFERRED SALESTYPE
- NPN TRANSISTOR
- HIGH VOLTAGE CAPABILITY
- LOW SPREAD OF DYNAMIC PARAMETERS
- MINIMUM LOT-TO-LOT SPREAD FOR RELIABLE OPERATION
- VERY HIGH SWITCHING SPEED
- THROUGH HOLE I²PAK (TO-262) POWER PACKAGE IN TUBE (SUFFIX "-1")

APPLICATIONS:

- ELECTRONIC BALLASTS FOR FLUORESCENT LIGHTING

DESCRIPTION

The device is manufactured using high voltage Multi-Epitaxial Planar technology for high switching speeds and medium voltage capability. It uses a Cellular Emitter structure with planar edge termination to enhance switching speeds while maintaining the wide RBSOA.

The device is designed for use in lighting applications and low cost switch-mode power supplies.

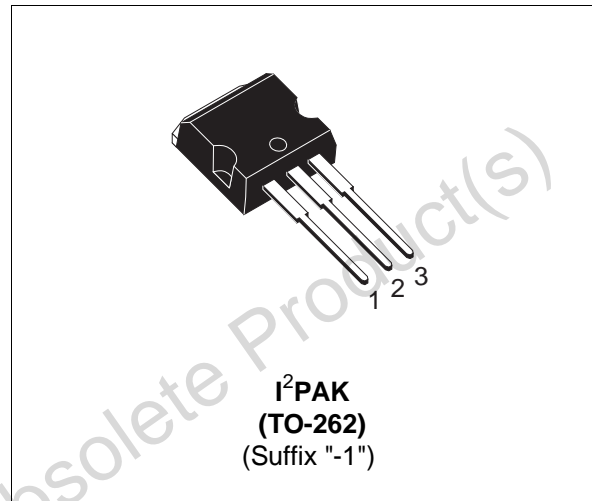

INTERNAL SCHEMATIC DIAGRAM

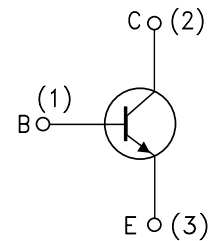

SC06960

ABSOLUTE MAXIMUM RATINGS

Symbol	Parameter	Value	Unit
V _{CES}	Collector-Emitter Voltage (V _{BE} = 0)	700	V
V _{CEO}	Collector-Emitter Voltage (I _B = 0)	400	V
V _{EBO}	Emitter-Base Voltage (I _C = 0)	9	V
I _C	Collector Current	4	A
I _{CM}	Collector Peak Current (t _p < 5 ms)	8	A
I _B	Base Current	2	A
I _{BM}	Base Peak Current (t _p < 5 ms)	4	A
P _{tot}	Total Dissipation at T _C = 25 °C	70	W
T _{stg}	Storage Temperature	-65 to 150	°C
T _j	Max. Operating Junction Temperature	150	°C

BULB128-1

THERMAL DATA

R _{thj-case}	Thermal Resistance Junction-Case	Max	1.78	°C/W
R _{thj-amb}	Thermal Resistance Junction-Ambient	Max	62.5	°C/W

ELECTRICAL CHARACTERISTICS (T_{case} = 25 °C unless otherwise specified)

Symbol	Parameter	Test Conditions	Min.	Typ.	Max.	Unit
I _{CES}	Collector Cut-off Current (V _{BE} = 0)	V _{CE} = 700 V V _{CE} = 700 V T _C = 125 °C			100 500	μA μA
V _{EBO}	Emitter-Base Voltage (I _C = 0)	I _E = 10 mA	9			V
V _{CEO(sus)*}	Collector-Emitter Sustaining Voltage (I _B = 0)	I _C = 100 mA L = 25 mH	400			V
I _{CEO}	Collector Cut-Off Current (I _B = 0)	V _{CE} = 400 V			250	μA
V _{CE(sat)*}	Collector-Emitter Saturation Voltage	I _C = 0.5 A I _B = 0.1 A I _C = 1 A I _B = 0.2 A I _C = 2.5 A I _B = 0.5 A I _C = 4 A I _B = 1 A		0.5	0.7 1 1.5	V V V V
V _{BE(sat)*}	Base-Emitter Saturation Voltage	I _C = 0.5 A I _B = 0.1 A I _C = 1 A I _B = 0.2 A I _C = 2.5 A I _B = 0.5 A			1.1 1.2 1.3	V V V
h _{FE*}	DC Current Gain	I _C = 10 mA V _{CE} = 5 V I _C = 2 A V _{CE} = 5 V	10 14		28	
t _s t _f	RESISTIVE LOAD Storage Time Fall Time	V _{CC} = 125 V I _C = 2 A I _{B1} = 0.4 A I _{B2} = -0.4 A T _p = 30 μs (see fig.2)	1.5	0.2	3 0.4	μs μs
t _s t _f	INDUCTIVE LOAD Storage Time Fall Time	I _C = 2 A I _{B1} = 0.4 A V _{BE(off)} = -5 V R _{BB} = 0 Ω V _{clamp} = 200 V (see fig.1)		0.6 0.1	1 0.2	μs μs

* Pulsed: Pulse duration = 300 μs, duty cycle 1.5 %

Safe Operating Areas

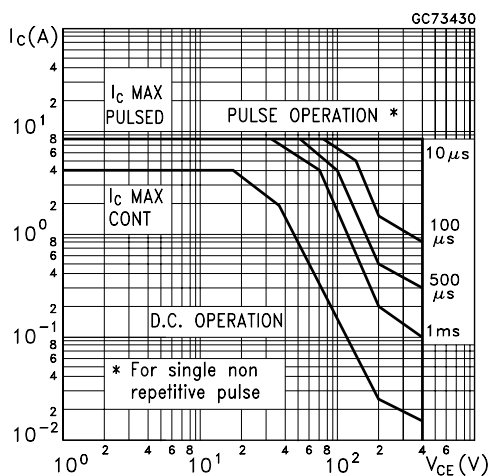

Derating Curve

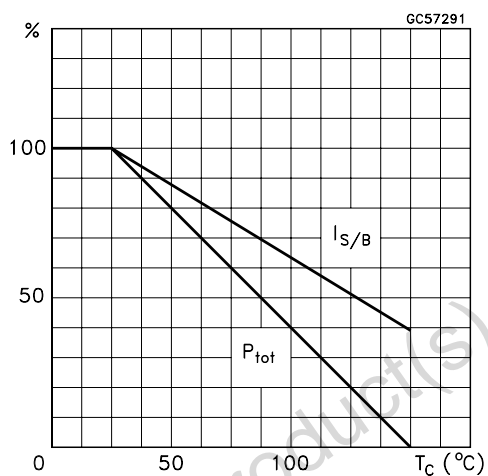

DC Current Gain

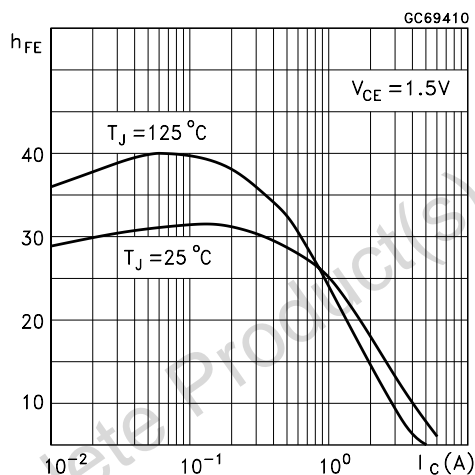

DC Current Gain

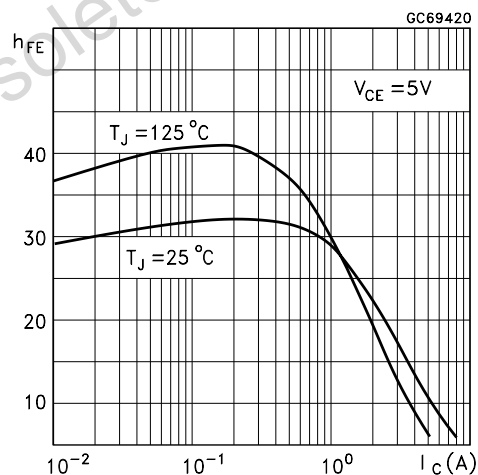

Collector Emitter Saturation Voltage

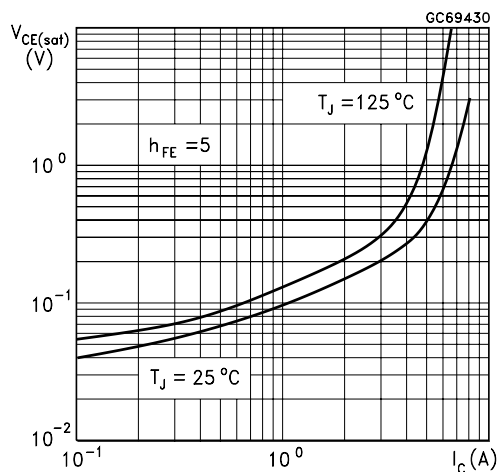

Base Emitter Saturation Voltage

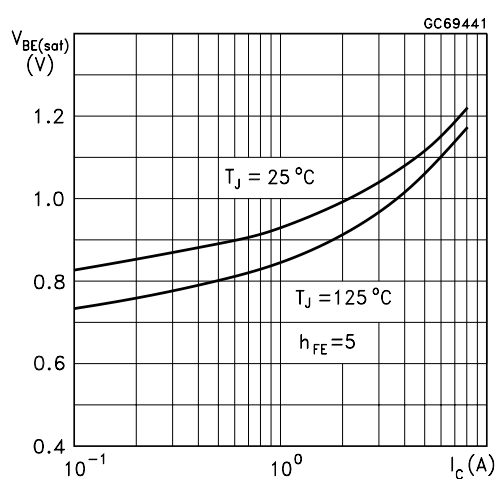

Inductive Fall Time

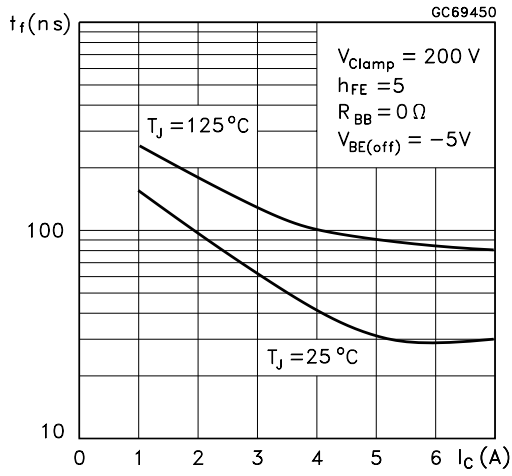

Inductive Storage Time

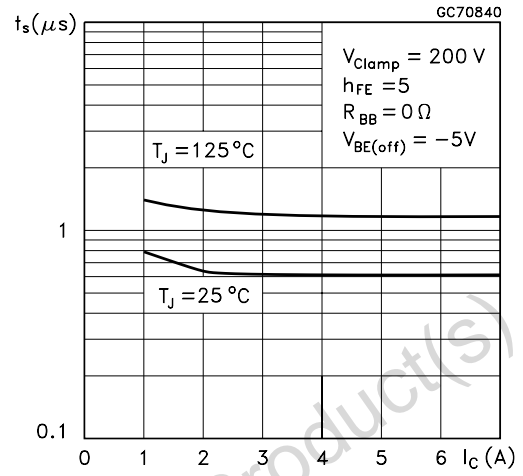

Resistive Fall Time

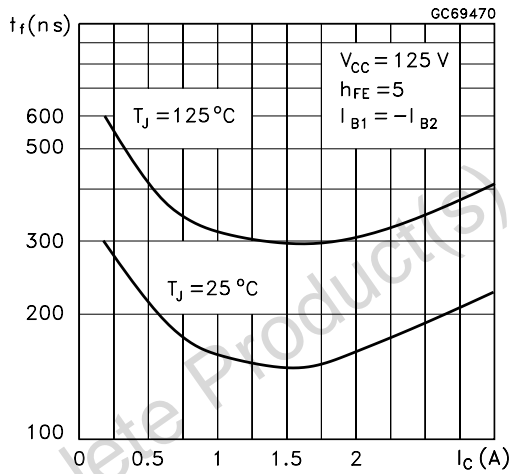

Resistive Load Storage Time

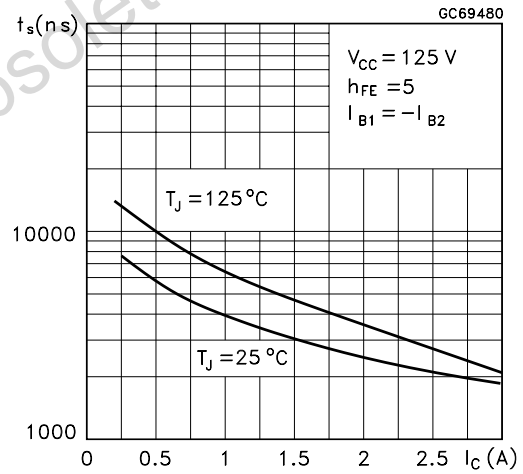

Reverse Biased SOA

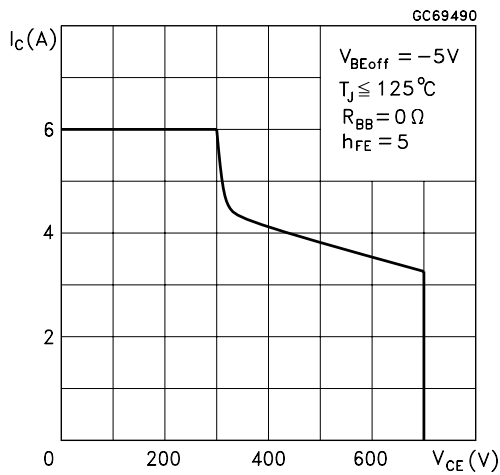

Figure 1: Inductive Load Switching Test Circuit.

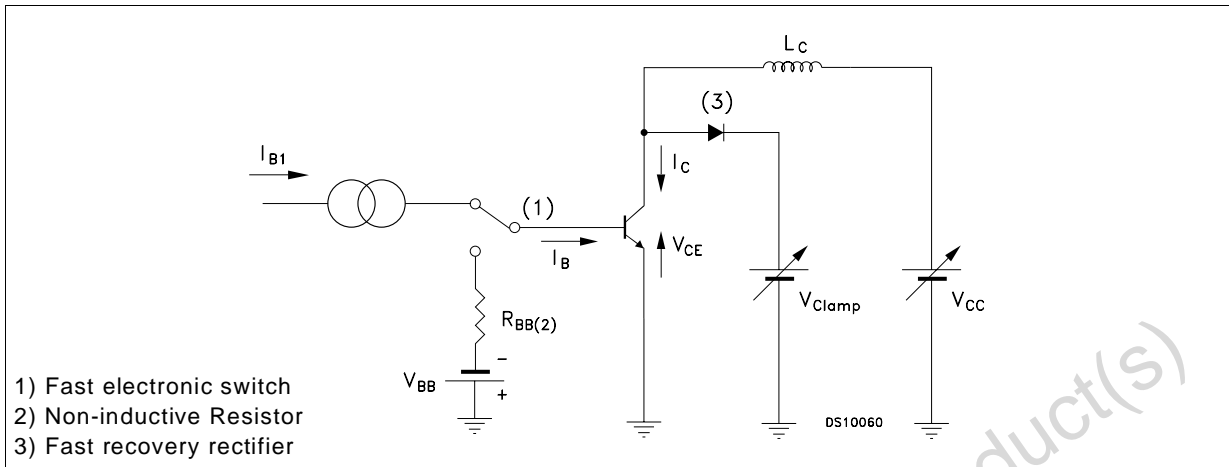
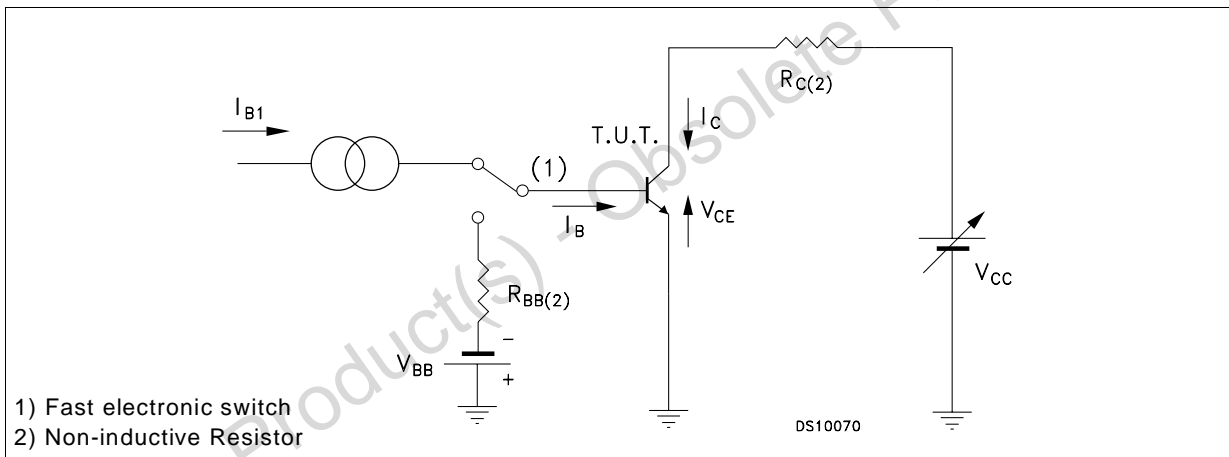
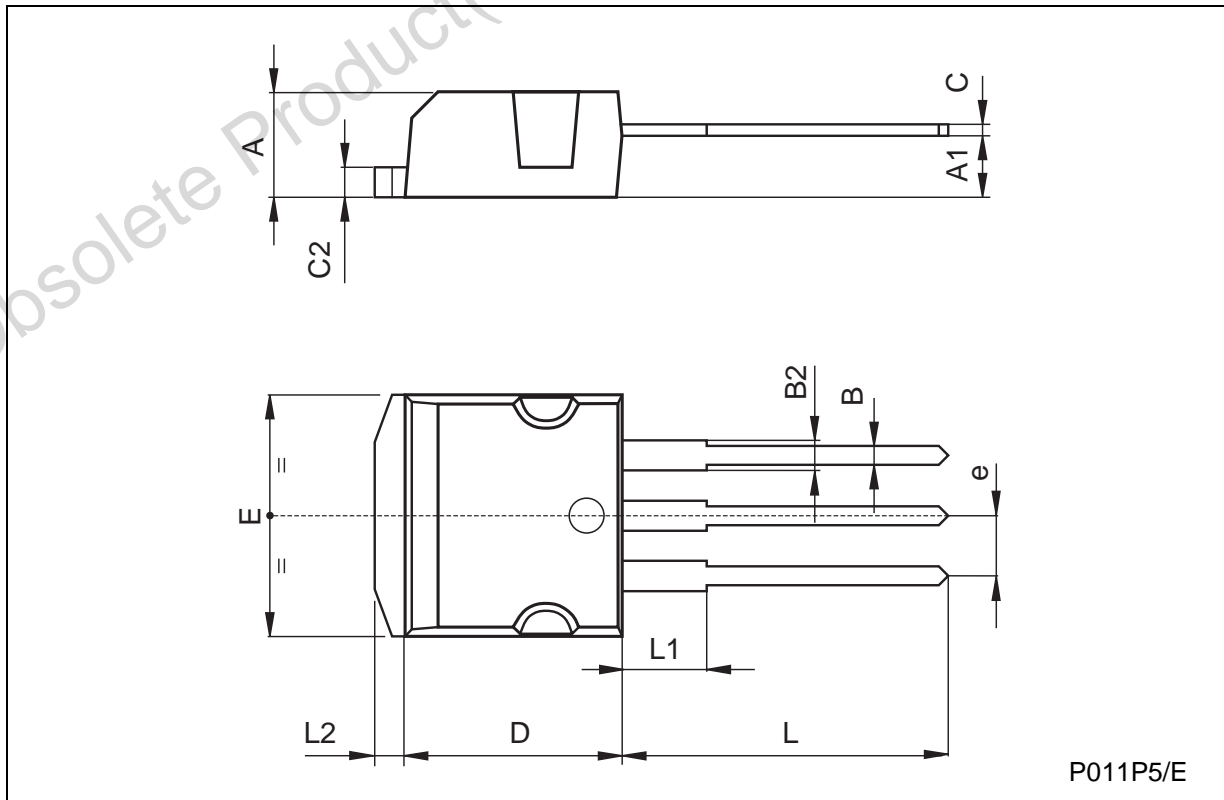

Figure 2: Resistive Load Switching Test Circuit.



TO-262 (I²PAK) MECHANICAL DATA

DIM.	mm			inch		
	MIN.	TYP.	MAX.	MIN.	TYP.	MAX.
A	4.4		4.6	0.173		0.181
A1	2.49		2.69	0.098		0.106
B	0.7		0.93	0.027		0.036
B2	1.14		1.7	0.044		0.067
C	0.45		0.6	0.017		0.023
C2	1.23		1.36	0.048		0.053
D	8.95		9.35	0.352		0.368
e	2.4		2.7	0.094		0.106
E	10		10.4	0.393		0.409
L	13.1		13.6	0.515		0.531
L1	3.48		3.78	0.137		0.149
L2	1.27		1.4	0.050		0.055



P011P5/E

Obsolete Product(s) - Obsolete Product(s)

Information furnished is believed to be accurate and reliable. However, STMicroelectronics assumes no responsibility for the consequences of use of such information nor for any infringement of patents or other rights of third parties which may result from its use. No license is granted by implication or otherwise under any patent or patent rights of STMicroelectronics. Specification mentioned in this publication are subject to change without notice. This publication supersedes and replaces all information previously supplied. STMicroelectronics products are not authorized for use as critical components in life support devices or systems without express written approval of STMicroelectronics.

The ST logo is a trademark of STMicroelectronics.

All other names are the property of their respective owners.

© 2003 STMicroelectronics – All Rights reserved



STMicroelectronics GROUP OF COMPANIES

Australia - Belgium - Brazil - Canada - China - Czech Republic - Finland - France - Germany - Hong Kong - India - Israel - Italy - Japan - Malaysia - Malta - Morocco - Singapore - Spain - Sweden - Switzerland - United Kingdom - United States.

<http://www.st.com>

Looking for pricing, stock, or lifecycle information?

Click below to explore more details on WIN SOURCE:

-  [View BULB128-1 on WIN SOURCE](#)
-  [STMicroelectronics Information](#)

Optimize Your Supply Chain with WIN SOURCE Solutions

-  Global Sourcing Solution
-  Obsolete Management
-  Cost Control Management
-  Shortage Management
-  Alternative Solution
-  Excess Inventory Management