



**THE DATASHEET OF
LQH32NZ3R3K23L**



CHIP COIL (CHIP INDUCTORS) LQH32NZ□□□□23L
Murata Standard Reference Specification [AEC-Q200]

1. Scope

This reference specification applies to Wire Wound Chip Coil (Chip Inductors) LQH32NZ Series for Automotive Electronics based on AEC-Q200 except for Power train and Safety.

2. Part Numbering

(ex) LQ H 32 N Z 1R0 K 2 3 L
 Product ID Structure Dimension Applications Category Inductance Tolerance Features Electrode Packaging
 (L×W) and Characteristics L:Taping

3. Rating

- Operating Temperature Range. -40 to +105°C
- Storage Temperature Range. -40 to +105°C

| Customer's Part Number | MURATA Part Number | Inductance | | Q (min.) | DC Resistance (Ω max.) | Self Resonant Frequency (MHz min.) | Rated Current (mA) | ESD 5A : 8kV |
|------------------------|--------------------|------------|---------------|----------|------------------------|------------------------------------|--------------------|--------------|
| | | (μH) | Tolerance (%) | | | | | |
| | LQH32NZ1R0K23L | 1.0 | K:±10 | 20 | 0.5 | 100 | 445 | 5A |
| | LQH32NZ1R2K23L | 1.2 | | | 0.6 | | 425 | |
| | LQH32NZ1R5K23L | 1.5 | | | 0.7 | 75 | 400 | |
| | LQH32NZ1R8K23L | 1.8 | | | 0.8 | 60 | 390 | |
| | LQH32NZ2R2K23L | 2.2 | | | 0.9 | 50 | 370 | |
| | LQH32NZ2R7K23L | 2.7 | | | 1.0 | 43 | 320 | |
| | LQH32NZ3R3K23L | 3.3 | | | 1.1 | 38 | 300 | |
| | LQH32NZ3R9K23L | 3.9 | | | 1.2 | 35 | 290 | |
| | LQH32NZ4R7K23L | 4.7 | | | 1.3 | 31 | 270 | |
| | LQH32NZ5R6K23L | 5.6 | | | 1.5 | 28 | 250 | |
| | LQH32NZ6R8K23L | 6.8 | | | 1.6 | 25 | 240 | |
| | LQH32NZ8R2K23L | 8.2 | | | 1.8 | 23 | 225 | |
| | LQH32NZ100J23L | 10 | | | J:± 5 | 35 | 2.0 | |
| | LQH32NZ120J23L | 12 | 2.2 | 18 | | | 180 | |
| | LQH32NZ150J23L | 15 | 2.5 | 16 | | | 170 | |
| | LQH32NZ180J23L | 18 | 2.8 | 15 | | | 165 | |
| | LQH32NZ220J23L | 22 | 3.1 | 14 | | | 150 | |
| | LQH32NZ270J23L | 27 | 3.5 | 13 | | | 125 | |
| | LQH32NZ330J23L | 33 | 3.9 | 12 | | | 115 | |
| | LQH32NZ390J23L | 39 | 4.3 | 11 | | 110 | | |
| | LQH32NZ470J23L | 47 | 4.9 | | | 100 | | |
| | LQH32NZ560J23L | 56 | 5.5 | 10 | | 85 | | |
| | LQH32NZ680J23L | 68 | 6.2 | 9.0 | | 80 | | |
| | LQH32NZ820J23L | 82 | 7.0 | 8.5 | | 70 | | |
| | LQH32NZ101J23L | 100 | 8.0 | 8.0 | | 80 | | |
| | LQH32NZ121J23L | 120 | 8.0 | 7.5 | | 75 | | |
| | LQH32NZ151J23L | 150 | 9.3 | 7.0 | | 70 | | |
| | LQH32NZ181J23L | 180 | 10.2 | 6.0 | | 65 | | |
| | LQH32NZ221J23L | 220 | 11.8 | 5.5 | | | | |
| | LQH32NZ271J23L | 270 | 12.5 | 5.0 | | | | |
| | LQH32NZ331J23L | 330 | 13.0 | | | | | |
| | LQH32NZ391J23L | 390 | 22.0 | | 50 | | | |
| | LQH32NZ471J23L | 470 | 25.0 | 25.0 | 45 | | | |

4. Testing Conditions

《Unless otherwise specified》

Temperature : Ordinary Temperature (15 to 35°C)
 Humidity : Ordinary Humidity (25 to 85 %(RH))

《In case of doubt》

Temperature : 20 ± 2°C
 Humidity : 60 to 70 %(RH)
 Atmospheric Pressure : 86 to 106 kPa

5. Appearance and Dimensions (No marking)

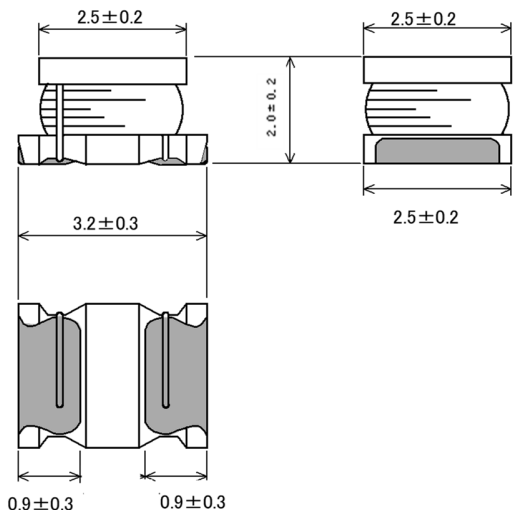

* No Marking.

(in mm)

■ Unit Mass (Typical value)
 0.060g

6. Electrical Performance

| No. | Item | Specification | Test Method |
|-----|--------------------------------|--|---|
| 6.1 | Inductance | Inductance shall meet item 3. | Measuring Equipment : KEYSIGHT 4192A or equivalent Measuring Frequency : 1MHz/ 1.0 to 390 μH 1kHz / 470μH |
| 6.2 | Q | | Measuring Equipment : KEYSIGHT 4192A or equivalent Measuring Frequency : 1MHz/ 1.0 to 82 μH 796kHz / 100 to 470μH |
| 6.2 | DC Resistance | DC Resistance shall meet item 3. | Measuring Equipment : Digital multi meter |
| 6.3 | Self Resonant Frequency(S.R.F) | S.R.F shall meet item 3. | Measuring Equipment : KEYSIGHT E4991A or equivalent |
| 6.4 | Rated Current | Self temperaturer rise shall be limited to 20°C max. Inductance Change : within ± 10% | The rated current is applied. |

7. AEC-Q200 Requirement

7.1 Performance (based on Table 5 for Magnetics(Inductors / Transformer)
 AEC-Q200 Rev.D issued June. 1 2010

| AEC-Q200 | | | Murata Specification / Deviation | | | | |
|-------------------|---------------------------|--|---|------------|-----------|-------------------|-------------|
| No | Stress | Test Method | | | | | |
| 3 | High Temperature Exposure | 1000hours at 105 deg C Set for 24hours at room temperature, then measured. | Meet Table A after testing. Table A <table border="1" style="margin-left: auto; margin-right: auto;"> <tr> <td>Appearance</td> <td>No damage</td> </tr> <tr> <td>Inductance change</td> <td>Within ±10%</td> </tr> </table> | Appearance | No damage | Inductance change | Within ±10% |
| Appearance | No damage | | | | | | |
| Inductance change | Within ±10% | | | | | | |
| 4 | Temperature Cycling | 1000cycles -40 deg C to + 105deg C Set for 24hours at room temperature, then measured. | Meet Table A after testing. | | | | |

| AEC-Q200 | | | Murata Specification / Deviation | | | | |
|----------------------|------------------------------|---|---|------------|-----------|----------------------|-------------|
| No | Stress | Test Method | | | | | |
| 7 | Biased Humidity | 1000hours at 85 deg C, 85%RH unpowered.. | Meet Table A after testing. | | | | |
| 8 | Operational Life | Apply 105 deg C 1000 hours Set for 24hours at room temperature, then measured | Meet Table A after testing. | | | | |
| 9 | External Visual | Visual inspection | No abnormalities | | | | |
| 10 | Physical Dimension | Meet ITEM 5 (Style and Dimensions) | No defects | | | | |
| 12 | Resistance to Solvents | Per MIL-STD-202 Method 215 | Not Applicable | | | | |
| 13 | Mechanical Shock | Per MIL-STD-202 Method 213 100g's/6ms/Half sine | Meet Table A after testing. | | | | |
| 14 | Vibration | 5g's for 20 minutes, 12cycles eah of 3 orientations Test from 10-2000Hz. 12cycles each of 3 orientations | Meet Table A after testing. | | | | |
| 15 | Resistance to Soldering Heat | No-heating Solder temperature 260C+/-5 deg C Immersion time 10s | Meet Table A after testing. | | | | |
| 17 | ESD | Per AEC-Q200-002 | ESD Rank: Refer to Item 3. Rating. No defects | | | | |
| 18 | Solderbility | Per J-STD-002 | Method B : Not Applicable 95% of the terminations is to be soldered. (Except exposed wire) | | | | |
| 19 | Electrical Characterization | Measured : Inductance | No defects | | | | |
| 20 | Flammability | Per UL-94 | Not Applicable | | | | |
| 21 | Board Flex | Epoxy-PCB(1.6mm) Deflection 2mm(min) 60s minimum holding time | Murata deviation request: 5s Meet Table B after testing. <u>Table B</u> <table border="1" style="margin-left: auto; margin-right: auto;"> <tr> <td>Appearance</td> <td>No damage</td> </tr> <tr> <td>DC resistance change</td> <td>Within ±10%</td> </tr> </table> | Appearance | No damage | DC resistance change | Within ±10% |
| Appearance | No damage | | | | | | |
| DC resistance change | Within ±10% | | | | | | |
| 22 | Terminal Strength | Per AEC-Q200-006 A force of 17.7N for 60s | No defects | | | | |

8. Specification of Packaging

8.1 Appearance and Dimensions of plastic tape

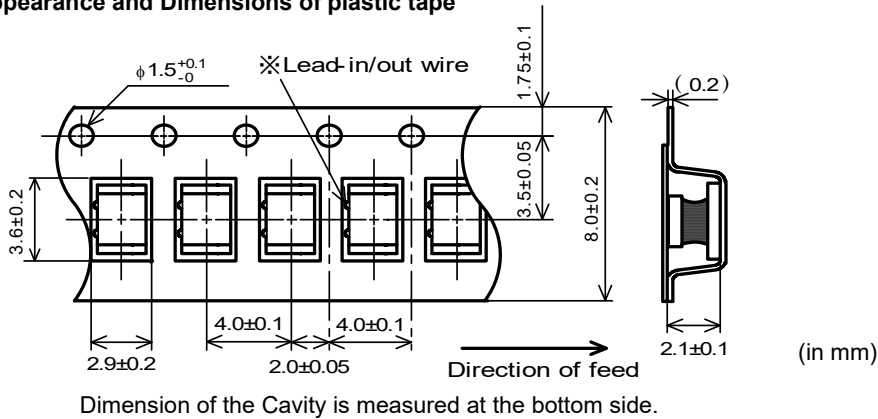

8.2 Specification of Taping

- (1) Packing quantity (standard quantity)
2,000 pcs / reel
- (2) Packing Method
Products shall be packed in the each embossed cavity of plastic tape and sealed by cover tape.
- (3) Sprocket hole
The sprocket holes are to the right as the tape is pulled toward the user.
- (4) Spliced point
Plastic tape and Cover tape has no spliced point.
- (5) Missing components number
Missing components number within 0.025 % of the number per reel or 1 pc., whichever is greater, and are not continuous. The specified quantity per reel is kept.

8.3 Pull Strength

| | |
|-----------------------|----------|
| Embossed carrier tape | 10N min. |
| Cover tape | 5N min. |

8.4 Peeling off force of cover tape

| | |
|----------------------|---|
| Speed of Peeling off | 300mm/min |
| Peeling off force | 0.2 to 0.7N (minimum value is typical) |

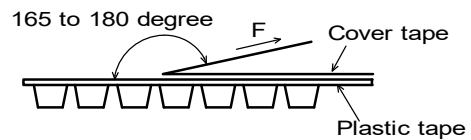

8.5 Dimensions of Leader-tape, Trailer and Reel

There shall be leader-tape (cover tape) and trailer-tape (empty tape) as follows.

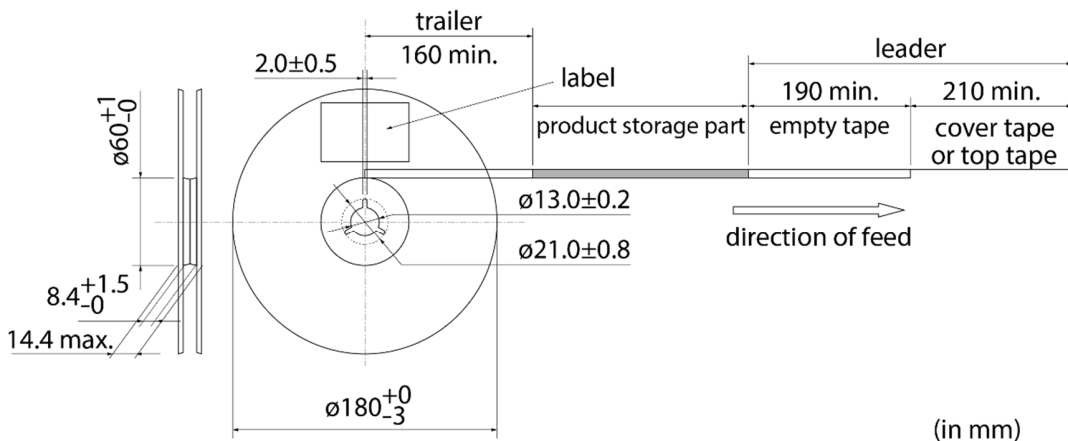

8.6 Marking for reel

Customer part number, MURATA part number, Inspection number(*1), RoHS marking(*2), Quantity etc ...

*1) <Expression of Inspection No.>

| | | |
|-----|------|-----|
| □□ | 0000 | xxx |
| (1) | (2) | (3) |

(1) Factory Code

(2) Date

First digit : Year / Last digit of year

Second digit : Month / Jan. to Sep. → 1 to 9, Oct. to Dec. → O, N, D

Third, Fourth digit : Day

(3) Serial No.

*2) « Expression of RoHS marking » ROHS - $\frac{Y}{(1)}$ (Δ)
(2)

(1) RoHS regulation conformity

(2) MURATA classification number

8.7 Marking for Outside package (corrugated paper box)

Customer name, Purchasing order number, Customer part number, MURATA part number, RoHS marking (*2), Quantity, etc ...

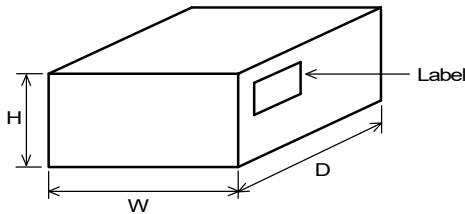
8.8 Specification of Outer Case

| Outer Case Dimensions (mm) | | | Standard Reel Quantity in Outer Case (Reel) |
|----------------------------|-----|----|---|
| W | D | H | |
| 186 | 186 | 93 | 5 |

* Above Outer Case size is typical. It depends on a quantity of an order.

9. ⚠ Caution**9.1 Limitation of Applications**

Please contact us before using our products for the applications listed below which require especially high reliability for the prevention of defects which might directly cause damage to the third party's life, body or property.

- | | |
|-----------------------------------|--|
| (1) Aircraft equipment | (6) Disaster prevention / crime prevention equipment |
| (2) Aerospace equipment | (7) Traffic signal equipment |
| (3) Undersea equipment | (8) Transportation equipment (trains, ships, etc.) |
| (4) Power plant control equipment | (9) Applications of similar complexity and /or reliability requirements to the applications listed in the above. |
| (5) Medical equipment | |

9.2 Precautions on rating

Do not use the products in excess of their rated current. Doing so may cause the product to generate heat, resulting in short circuit between wires, wire breakage, or melted solder, which may cause dropping of parts.

9.3 Fail-safe

Be sure to provide an appropriate fail-safe function on your product to prevent a second damage that may be caused by the abnormal function or the failure of our product.

9.4 Corrosive gas

Please refrain from use since contact with environments with corrosive gases (sulfur gas [hydrogen sulfide, sulfur dioxide, etc.], chlorine, ammonia, etc.) or oils (cutting oil, silicone oil, etc.) that have come into contact with the previously stated corrosive gas environment will result in deterioration of product quality or an open from deterioration due to corrosion of product electrode, etc. We will not bear any responsibility for use under these environments.

10. Notice

This product is designed for solder mounting. (Reflow soldering only)
 Please consult us in advance for applying other mounting method such as conductive adhesive.

10.1 Land pattern designing (Reflow Soldering)

Recommended land pattern for reflow soldering is as follows:
 It has been designed for Electric characteristics and solderability.
 Please follow the recommended patterns. Otherwise, their performance which includes electrical performance or solderability may be affected, or result to "position shift" in soldering process.

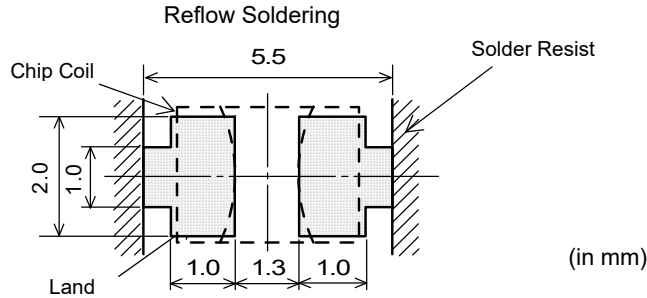

10.2 Flux, Solder

| | |
|--------|--|
| Flux | <ul style="list-style-type: none"> • Use rosin-based flux. • Don't use highly acidic flux with halide content exceeding 0.2(wt)% (chlorine conversion value). • Don't use water-soluble flux. |
| Solder | <ul style="list-style-type: none"> • Use Sn-3.0Ag-0.5Cu solder • Standard thickness of solder paste : 100µm to 150µm |

Other flux (except above) Please contact us for details, then use.

10.3 Reflow soldering conditions

- Pre-heating should be in such a way that the temperature difference between solder and product surface is limited to 150°C max. Cooling into solvent after soldering also should be in such a way that the temperature difference is limited to 100°C max.
 Insufficient pre-heating may cause cracks on the product, resulting in the deterioration of products quality.
- Standard soldering profile and the limit soldering profile is as follows.
 The excessive limit soldering conditions may cause leaching of the electrode and / or resulting in the deterioration of product quality.

Reflow soldering profile

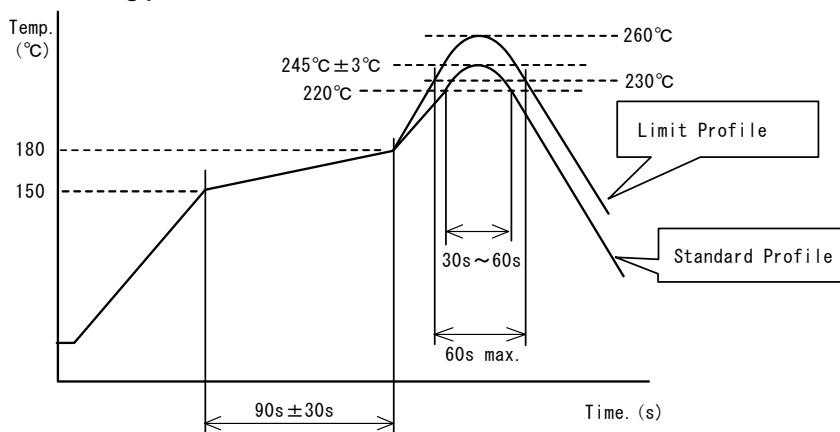

| | Standard Profile | Limit Profile |
|------------------|---------------------|----------------------|
| Pre-heating | 150~180°C、90s±30s | |
| Heating | above 220°C、30s~60s | above 230°C、60s max. |
| Peak temperature | 245±3°C | 260°C,10s |
| Cycle of reflow | 2 times | 2time |

10.4 Reworking with soldering iron.

The following conditions must be strictly followed when using a soldering iron.

| | |
|-----------------------|--------------|
| Pre-heating | 150°C, 1 min |
| Tip temperature | 350°C max. |
| Soldering iron output | 80W max. |
| Tip diameter | φ3mm max. |
| Soldering time | 3 (+1,-0)s |
| Times | 2 times |

Note : Do not directly touch the products with the tip of the soldering iron in order to prevent the crack on the products due to the thermal shock.

10.5 Solder Volume

- Solder shall be used not to be exceeded the upper limits as shown below.
- Accordingly increasing the solder volume, the mechanical stress to Chip is also increased. Exceeding solder volume may cause the failure of mechanical or electrical performance.

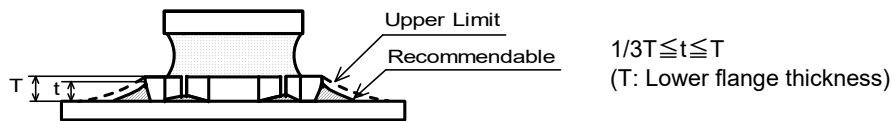

10.6 Product's location

The following shall be considered when designing and laying out P.C.B.'s.

- (1) P.C.B. shall be designed so that products are not subject to the mechanical stress due to warping the board.

[Products direction]

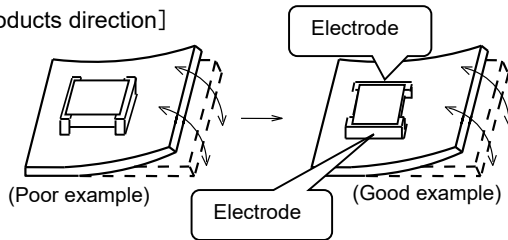

Products shall be located in the sideways direction (Length:a>b) to the mechanical stress.

- (2) Components location on P.C.B. separation.

It is effective to implement the following measures, to reduce stress in separating the board. It is best to implement all of the following three measures; however, implement as many measures as possible to reduce stress.

| Contents of Measures | Stress Level |
|--|--------------|
| (1) Turn the mounting direction of the component parallel to the board separation surface. | $A > D *1$ |
| (2) Add slits in the board separation part. | $A > B$ |
| (3) Keep the mounting position of the component away from the board separation surface. | $A > C$ |

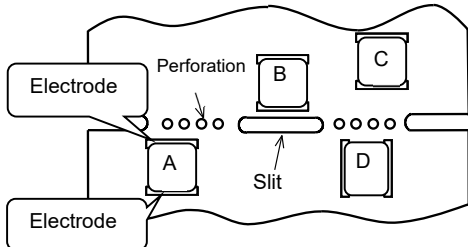

*1 $A > D$ is valid when stress is added vertically to the perforation as with Hand Separation. If a Cutting Disc is used, stress will be diagonal to the PCB, therefore $A > D$ is invalid.

- (3) Mounting Components Near Screw Holes

When a component is mounted near a screw hole, it may be affected by the board deflection that occurs during the tightening of the screw. Mount the component in a position as far away from the screw holes as possible

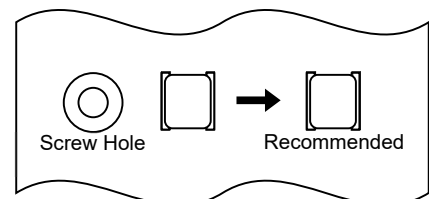

10.7 Cleaning Conditions

Products shall be cleaned on the following conditions.

- (1) Cleaning temperature shall be limited to 60°C max.(40°C max for IPA.)
- (2) Ultrasonic cleaning shall comply with the following conditions with avoiding the resonance phenomenon at the mounted products and P.C.B.

Power : 20 W / l max. Frequency : 28kHz to 40kHz Time : 5 minutes max.

- (3) Cleaner

1. Alternative cleaner
 - Isopropyl alcohol (IPA)
2. Aqueous agent
 - PINE ALPHA ST-100S

- (4) There shall be no residual flux and residual cleaner after cleaning.

In the case of using aqueous agent, products shall be dried completely after rinse with de-ionized water in order to remove the cleaner.

- (5) Other cleaning

Please contact us.

10.8 Resin coating

The inductance value may change due to high cure-stress of resin to be used for coating/molding products. An open circuit issue may occur by mechanical stress caused by the resin, amount/cured shape of resin, or operating condition etc. Some resin contains some impurities or chloride possible to generate chlorine by hydrolysis under some operating condition may cause corrosion of wire of coil, leading to open circuit. So, please pay your careful attention when you select resin in case of coating/molding the products with the resin. Prior to use the coating resin, please make sure no reliability issue is observed by evaluating products mounted on your board.

10.9 Caution for use

- Sharp material such as a pair of tweezers or other material such as bristles of cleaning brush, shall not be touched to the winding portion to prevent the breaking of wire.
- Mechanical shock should not be applied to the products mounted on the board to prevent the breaking of the core.

10.10 Handling of a substrate

After mounting products on a substrate, do not apply any stress to the product caused by bending or twisting to the substrate when cropping the substrate, inserting and removing a connector from the substrate or tightening screw to the substrate.

Excessive mechanical stress may cause cracking in the product.

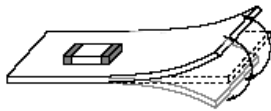
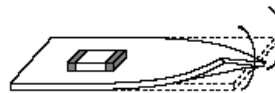
Bending**Twisting**

10.11 Storage and Handling Requirements

(1) Storage period

Use the products within 12 months after delivered.

Solderability should be checked if this period is exceeded.

(2) Storage conditions

- Products should be stored in the warehouse on the following conditions.

Temperature : -10 ~ 40°C

Humidity : 15 to 85% relative humidity No rapid change on temperature and humidity

The electrode of the products is coated with solder. Don't keep products in corrosive gases such as sulfur, chlorine gas or acid, or it may cause oxidization of electrode, resulting in poor solderability.

- Products should not be stored on bulk packaging condition to prevent the chipping of the core and the breaking of winding wire caused by the collision between the products.
- Products should be stored on the pallet for the prevention of the influence from humidity, dust and so on.
- Products should be stored in the warehouse without heat shock, vibration, direct sunlight and so on.

(3) Handling Condition

Care should be taken when transporting or handling product to avoid excessive vibration or mechanical shock.

11.  Note

(1) Please make sure that your product has been evaluated in view of your specifications with our product being mounted to your product.



(2) You are requested not to use our product deviating from the reference specifications.

(3) The contents of this reference specification are subject to change without advance notice.

Please approve our product specifications or transact the approval sheet for product specifications before ordering.

Looking for pricing, stock, or lifecycle information?

Click below to explore more details on WIN SOURCE:

-  [View LQH32NZ3R3K23L on WIN SOURCE](#)
-  [Murata Electronics North America Information](#)

Optimize Your Supply Chain with WIN SOURCE Solutions

-  Global Sourcing Solution
-  Obsolete Management
-  Cost Control Management
-  Shortage Management
-  Alternative Solution
-  Excess Inventory Management