



THE DATASHEET OF EVALM7LVMOSINVT0B01



EVAL-M7-LVMOS-INV user guide

Evaluation power board with M7 connector

About this document

Scope and purpose

This user guide provides an overview of the evaluation board EVAL-M7-LVMOS-INV, including its main features, key technical data, pin assignments, and mechanical dimensions.

Intended audience

This evaluation board is intended for all technical specialists who are familiar with motor control and power electronics converter systems, and is to be used under laboratory conditions.

EVAL-M7-LVMOS-INV is an evaluation power board with Infineon's 60 V OptiMOS™ power MOSFETs. This board features and demonstrates Infineon's OptiMOS™ N-channel power MOSFET technology for inverter circuitry at hard switching conditions. OptiMOS™ N-channel power MOSFETs were developed to increase efficiency, power density and cost-effectiveness. They were designed for high-performance applications and optimized for high switching frequencies. OptiMOS™ products offer the industry's best figure of merit. The MOSFETs used on this board are in a PG-TO252-3 (DPAK) package. This board is suitable for driving fans, pumps, and other smaller low-voltage motors. The output power is up to 300 W at 20 kHz carrier frequency.

The evaluation board EVAL-M7-LVMOS-INV was developed to support users during their first steps in designing applications with running any permanent magnet motors via sensorless sinusoidal field-oriented control.

Evaluation board

This board is to be used during the design-in phase, for evaluation and measurement of characteristics, and proof of data-sheet specifications.

Note: PCB and auxiliary circuits are NOT optimized for final customer design.

Important notice

Important notice

“Evaluation Boards and Reference Boards” shall mean products embedded on a printed circuit board (PCB) for demonstration and/or evaluation purposes, which include, without limitation, demonstration, reference and evaluation boards, kits and design (collectively referred to as “Reference Board”).

Environmental conditions have been considered in the design of the Evaluation Boards and Reference Boards provided by Infineon Technologies. The design of the Evaluation Boards and Reference Boards has been tested by Infineon Technologies only as described in this document. The design is not qualified in terms of safety requirements, manufacturing and operation over the entire operating temperature range or lifetime.

The Evaluation Boards and Reference Boards provided by Infineon Technologies are subject to functional testing only under typical load conditions. Evaluation Boards and Reference Boards are not subject to the same procedures as regular products regarding returned material analysis (RMA), process change notification (PCN) and product discontinuation (PD).

Evaluation Boards and Reference Boards are not commercialized products, and are solely intended for evaluation and testing purposes. In particular, they shall not be used for reliability testing or production. The Evaluation Boards and Reference Boards may therefore not comply with CE or similar standards (including but not limited to the EMC Directive 2004/EC/108 and the EMC Act) and may not fulfill other requirements of the country in which they are operated by the customer. The customer shall ensure that all Evaluation Boards and Reference Boards will be handled in a way which is compliant with the relevant requirements and standards of the country in which they are operated.

The Evaluation Boards and Reference Boards as well as the information provided in this document are addressed only to qualified and skilled technical staff, for laboratory usage, and shall be used and managed according to the terms and conditions set forth in this document and in other related documentation supplied with the respective Evaluation Board or Reference Board.

It is the responsibility of the customer’s technical departments to evaluate the suitability of the Evaluation Boards and Reference Boards for the intended application, and to evaluate the completeness and correctness of the information provided in this document with respect to such application.

The customer is obliged to ensure that the use of the Evaluation Boards and Reference Boards does not cause any harm to persons or third party property.

The Evaluation Boards and Reference Boards and any information in this document is provided "as is" and Infineon Technologies disclaims any warranties, express or implied, including but not limited to warranties of non-infringement of third party rights and implied warranties of fitness for any purpose, or for merchantability.

Infineon Technologies shall not be responsible for any damages resulting from the use of the Evaluation Boards and Reference Boards and/or from any information provided in this document. The customer is obliged to defend, indemnify and hold Infineon Technologies harmless from and against any claims or damages arising out of or resulting from any use thereof.

Infineon Technologies reserves the right to modify this document and/or any information provided herein at any time without further notice.

Safety precautions

Safety precautions

Note: Please note the following warnings regarding the hazards associated with development systems.

Table 1 Safety precautions

	<p>Warning: The DC link potential of this board is up to 1000 VDC. When measuring voltage waveforms by oscilloscope, high-voltage differential probes must be used. Failure to do so may result in personal injury or death.</p>
	<p>Warning: The evaluation or reference board contains DC bus capacitors which take time to discharge after removal of the main supply. Before working on the drive system, wait five minutes for capacitors to discharge to safe voltage levels. Failure to do so may result in personal injury or death. Darkened display LEDs are not an indication that capacitors have discharged to safe voltage levels.</p>
	<p>Warning: The evaluation or reference board is connected to the grid input during testing. Hence, high-voltage differential probes must be used when measuring voltage waveforms by oscilloscope. Failure to do so may result in personal injury or death. Darkened display LEDs are not an indication that capacitors have discharged to safe voltage levels.</p>
	<p>Warning: Remove or disconnect power from the drive before you disconnect or reconnect wires, or perform maintenance work. Wait five minutes after removing power to discharge the bus capacitors. Do not attempt to service the drive until the bus capacitors have discharged to zero. Failure to do so may result in personal injury or death.</p>
	<p>Caution: The heat sink and device surfaces of the evaluation or reference board may become hot during testing. Hence, necessary precautions are required while handling the board. Failure to comply may cause injury.</p>
	<p>Caution: Only personnel familiar with the drive, power electronics and associated machinery should plan, install, commission and subsequently service the system. Failure to comply may result in personal injury and/or equipment damage.</p>
	<p>Caution: The evaluation or reference board contains parts and assemblies sensitive to electrostatic discharge (ESD). Electrostatic control precautions are required when installing, testing, servicing or repairing the assembly. Component damage may result if ESD control procedures are not followed. If you are not familiar with electrostatic control procedures, refer to the applicable ESD protection handbooks and guidelines.</p>
	<p>Caution: A drive that is incorrectly applied or installed can lead to component damage or reduction in product lifetime. Wiring or application errors such as undersizing the motor, supplying an incorrect or inadequate AC supply, or excessive ambient temperatures may result in system malfunction.</p>
	<p>Caution: The evaluation or reference board is shipped with packing materials that need to be removed prior to installation. Failure to remove all packing materials that are unnecessary for system installation may result in overheating or abnormal operating conditions.</p>

Table of contents

About this document	1
Important notice	2
Safety precautions	3
Table of contents	4
1 The board at a glance	5
1.1 Delivery content	5
1.2 Block diagram.....	6
1.3 Main features	6
1.4 Board parameters and technical data.....	7
2 System and functional description	8
2.1 Commissioning.....	8
2.2 Getting started with IMD controller board EVAL-M7-D111T	8
2.2.1 System set-up.....	8
2.2.1.1 MCEWizard setup overview.....	9
2.2.1.2 MCEDesigner setup overview	11
2.3 Description of the functional blocks.....	13
2.3.1 EVAL-M7-LVMOS-INV functional groups	13
2.3.2 Bus voltage feedback	13
2.3.3 Current feedback configuration	14
2.3.4 Temperature measured with NTC on board	14
2.3.5 DC power supply	16
2.3.6 Protection function	17
3 System design	18
3.1 Schematics	18
3.2 Layout	19
3.3 Bill of material	20
3.4 Connector details	22
4 System performance	24
4.1 dv/dt test	24
4.2 Thermal performance test	24
4.3 Test results	25
5 References and appendices	27
5.1 References	27
5.2 Ordering details and other additional information	27
Revision history	28

The board at a glance

1 The board at a glance

The EVAL-M7-LVMOS-INV is an evaluation power board with M7 connector. Please refer to Chapter 2.2.1 for details of the M7 connector pinout assignment. This evaluation power board was designed to be driven by a control board that is compatible with the M7 connector. Such a control board is the EVAL-M7-D111T smart-driver control board, however, other control boards that are M7 connector-compatible can also be used to drive this power board. The power board can handle up to 300 W output power when the carrier frequency is 20 kHz (The load is a 24 V vacuum cleaner motor).

The main device on the evaluation board is the Infineon's 60 V OptiMOS™ power MOSFET. The part number is IPD033N06N. OptiMOS™ 60 V is optimized for synchronous rectification in switched mode power supply (SMPS). The better switching performance and lower $R_{DS(on)}$ can achieve lower losses when this device is used for low-voltage motor control, solar micro inverters, and fast switching DC-DC converters. Lower power losses lead to higher system efficiency. The IPD033N06N has 40% lower $R_{DS(on)}$ than alternative devices, which can reduce paralleling and increase power density.

The key features and functionality of this board are described in Chapter 1.3 with the main features of this document (UG-2021-30). The remaining chapters provide information on how to set up and use this evaluation board, and how to copy and/or modify the design according to specific user requirements.

Figure 1 depicts the evaluation board EVAL-M7-LVMOS-INV.

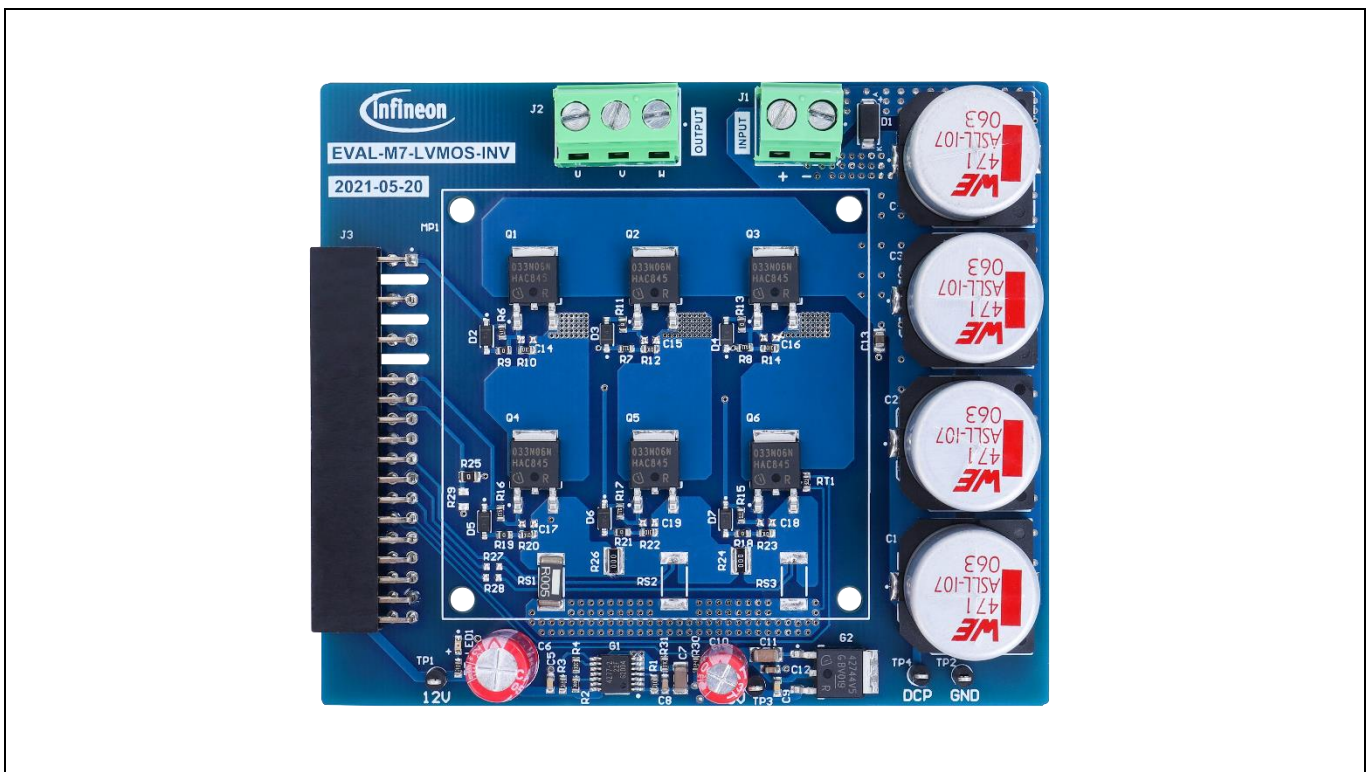

Figure 1 Evaluation board of EVAL-M7-LVMOS-INV

1.1 Delivery content

The scope of supply comprises only the board, as shown in Figure 1. The detailed ordering information is indicated in Table 2.

If users do not have the control board, the Infineon smart driver control board EVAL-M7-D111T can be used to evaluate the power board. Ordering information can be found in the following [link](#).

The board at a glance

Table 2 Ordering information

Base part number	Package	Standard pack		Part number for ordering
		Form	Quantity	
EVAL-M7-LVMOS-INV		Boxed	1	SP005555666
IPD033N06N	PG-TO252-3	taped		

1.2 Block diagram

Figure 2 shows the block diagram of EVAL-M7-LVMOS-INV and connections with the control board. An example control board such as the EVAL-M7-D111T can be used for the motor drive with sensorless or rotor angle and speed feedback. The IMD111T has 5 V output capability with a maximum current of 20 mA. The 5 V power supply on the EVAL-M7-LVMOS-INV board is optional if the application needs more current output capability, or if the control board is without 5 V output power supply.

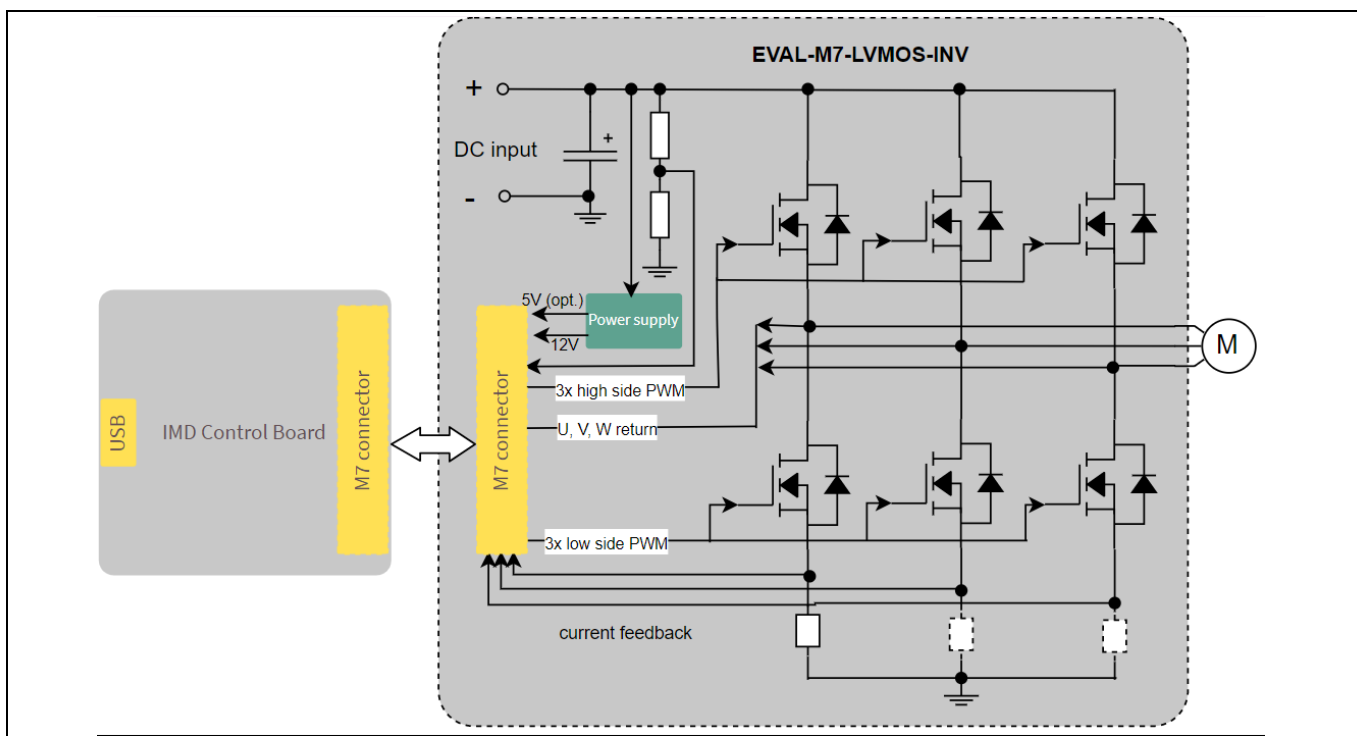

Figure 2 EVAL-M7-LVMOS-INV block diagram

1.3 Main features

EVAL-M7-LVMOS-INV is an evaluation board using Infineon’s 60 V OptiMOS™ power MOSFET. This board is suitable for permanent magnet synchronous motors or brushless direct current motors (PMSM or BLDC), controls for home appliances, fans, pumps, etc.

The main features of the OptiMOS™ IPD033N06N include:

- Optimized for synchronous rectification
- 100% avalanche tested
- Superior thermal resistance

The board at a glance

- N-channel, normal level
- Qualified according to JEDEC1 for target applications
- Pb-free lead plating; RoHS compliant
- Halogen-free according to IEC61249-2-21

The main features of the EVAL-M7-LVMOS-INV evaluation board include:

- 60 V OptiMOS™ power MOSFET used for the inverter section
- Single-shunt or leg-shunt current feedback configuration (as alternatives)
- 5 V and 15 V output power supply on the board
- PCB size is 80 mm x 93 mm, 2 layers, 1 oz copper
- RoHS-compliant

1.4 Board parameters and technical data

Table 3 includes the evaluation board parameters and technical details.

Table 3 Parameter

Parameter	Symbol	Conditions	Value	Unit
Input DC voltage	V_{IN}	DC voltage input	20~45	V
12 V output voltage	+12 V	Maximum 100 mA output current	12±5%	V
5 V output voltage	+5 V	Maximum 150 mA output current	5±5%	V
Maximum input power	P_{IN}	20 kHz carrier frequency with a fan motor (2 poles, 30 A, $L_d=L_q=15\ \mu\text{H}$, 120 kRPM)	300	W
Max. switching frequency	f_{SW}	$V_{CC}=12\ \text{V}$	40	kHz
Max. output phase current	$I_{\text{phase_rms}}$	$T_A=20\ ^\circ\text{C}$, $T_C=100\ ^\circ\text{C}$, air cooling, $f_{SW}=25\ \text{kHz}$	12	A_{RMS}
Max. DC bus voltage	$V_{DC(max)}$	Limited by low dropout regulator (LDO) maximum input voltage	45	V
PCB characteristics				
Material		1.6 mm thickness, 1 oz copper, 2 layers	FR4	
Dimensions		Length × width × height	93 × 80 × 22	mm
System environment				
Ambient temperature	T_{amb}	Non-condensing, maximum RH 95%	0 ~ 50	°C

2 System and functional description

2.1 Commissioning

The EVAL-M7-LVMOS-INV evaluation board is a power board and thus has no control function. Therefore, it should be used with an M7 connector-compatible control board. Figure 3 is an example of a system setup with Infineon iMOTION™ smart driver IMD111T control board EVAL-M7-D111T. The IMD111T is a motion control engine (MCE) that can be implemented as a ready-to-use solution for variable speed drives. Users who would like to drive the power board with the EVAL-M7-D111T control board can find more details in the Infineon user guide UG-2021-17. The IMD111T control board user guide describes how to use iMOTION™ tools to run the board.

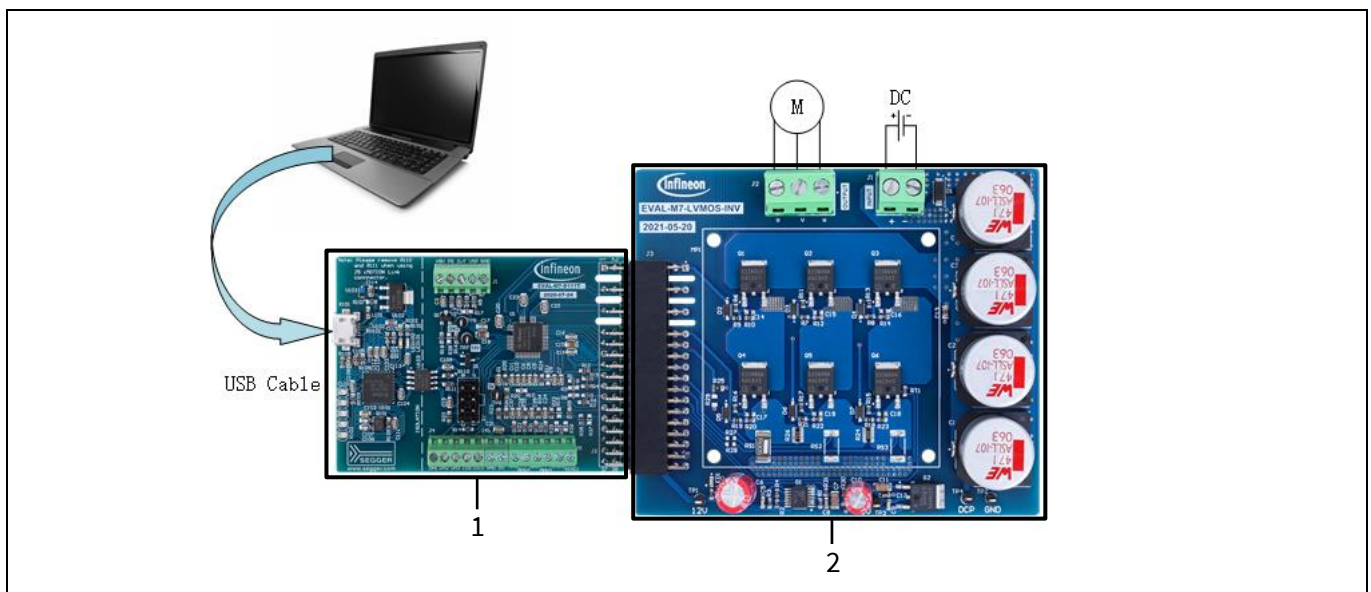

Figure 3 System setup example

1. EVAL-M7-D111T
2. EVAL-M7-LVMOS-INV

2.2 Getting started with IMD controller board EVAL-M7-D111T

Here is an explanation on how to set up the system and how to use the MCEWizard and MCEDesigner tools for creating and tuning users' motor parameters. The control board is the EVAL-M7-D111T. Figure 3 shows the system setup.

2.2.1 System set-up

Before using the EVAL-M7-D111T IMD control board to evaluate this power board, users should install the iMOTION™ development tools (MCEWizard and MCEDesigner) on their computer. The iMOTION™ development tools can be downloaded from the Infineon website ([link](#)). The following steps must then be executed to run the motor. Refer to Chapters 2.2.1.1 and 2.2.1.2 as well as to the MCEWizard and MCEDesigner user guide for more information.

1. Get the latest “IMD111T Software Package” available on the www.infineon.com/imotion-software website.
2. Connect a PC and the evaluation board via a USB cable or the iMOTION™ link.

3. Connect the DC source and target motor.
4. Use the MCEWizard to calculate and create a parameter text file. See the MCEWizard setup overview in Chapter 2.2.1.1 for more details.
5. Power-on the system and start the MCEDesigner tool to open the MCEDesigner default configuration file (.irc) for the IMD111T smart driver.
6. Program the firmware and calculated parameters into the flash. See the MCEDesigner setup overview in Chapter 2.2.1.2 for more details.
7. After programming successfully, click on the hammer icon to clear the fault signals if there is a red light at the bottom of MCEDesigner. When the system is ready, start the motor by clicking the green traffic light. Clicking the red traffic light stops the motor.

2.2.1.1 MCEWizard setup overview

MCEWizard defines control gains, limits and fault levels based on real number inputs, and converts gains and levels to parameter counts based on hardware and control limit settings. MCEWizard also exports parameters and variable scale factors to the MCEDesigner.

- Double-click the MCEWizard shortcut on the Windows desktop; the MCEWizard welcome page is shown in Figure 4.
- If users have the evaluation design kit MCEWizard configuration file, they only need to click the “Open System Configuration File” button and change the user’s motor parameters under test.
- But if users do not have this evaluation design kit MCEWizard configuration file, they need to execute the following steps.
 - a) Click the button “File” and select “Create System Configuration File”
 - b) Select the IMD111T device in the pop-up window
 - c) Click OK and return to the welcome page
 - d) Select “Customized Design for Expert User”
 - e) Click the “Next” button to answer all the questions concerning the hardware design and user test motor specification

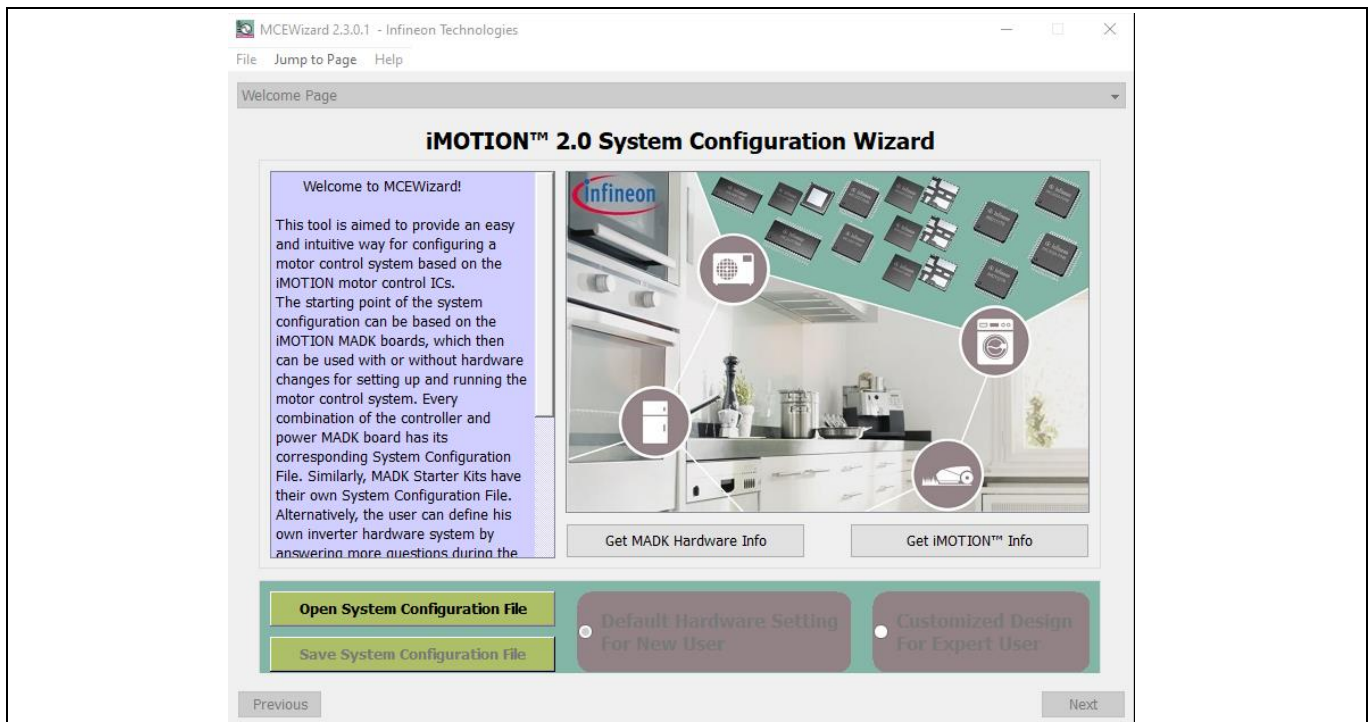

Figure 4 MCEWizard welcome page

Table 4 lists key questions to be answered in the MCEWizard in order to set up the system based on the evaluation board. The remaining set of questions also needs to be answered, including questions about OV/UV protection, fault conditions, startup setting, etc. The MCEWizard parameter setting is based on a 120 kRPM vacuum cleaner fan motor (2 poles, 30 A).

Table 4 MCEWizard setup overview table

Parameter	Value	Comment
Motor1 PWM frequency, current sensing configuration and control input on Option page	Fc<40 kHz, UART/VSP/duty/frequency Single/leg-shunt configuration	Key for selecting the IC working status
User motor parameters	Depends on the motor under test	Such as rated current, poles Lq, Ld, maximum RPM, etc.
DC bus sensing high resistor	120 kΩ on board	These resistors are on the power board
DC bus sensing low resistor	10 kΩ on board	The resistor is on the power board
Motor current input scaling	4.59 mV/A	Depends on the hardware design, single-shunt configuration
Current input to ADC offset voltage	415 mV	Depends on the hardware design
Overcurrent trip level	58 A	Depends on the rated current of the power board and motor
Catch spin	Enable/disable	

After answering all the questions, go to the “Verify & Save Page” (see Figure 5). On that page, click the “Calculate Parameters” button to create the parameters. Then click the “Export to MCEDesigner File” button to export and save the parameter text file.

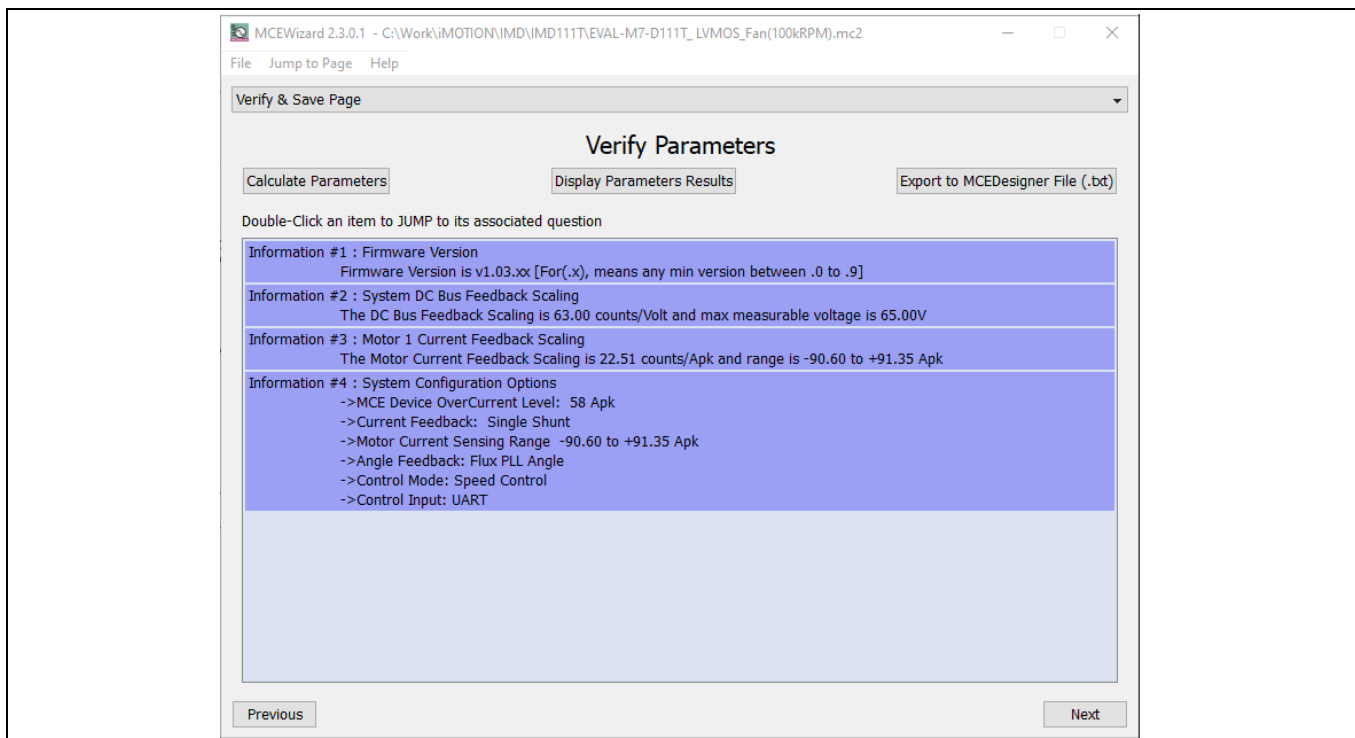

Figure 5 Verify & Save page of MCEWizard

2.2.1.2 MCEDesigner setup overview

The MCEDesigner is a tool used for programming code, and tuning the evaluation board. It also has the possibility to read from 16-bit MCE variable registers, and to read/write to MCE parameter registers. The MCEDesigner displays both real value and count value for all variable registers, and selects parameter registers. The count value is the conversion from real value to a digital number. The registers’ value format can be selected from the “Performance > Tuning Value Format” pop-up window.

After installing the MCEDesigner installer, a shortcut for opening the tool will be available on the Windows desktop. Take the following steps to quick-start the MCEDesigner:

- Double-click the shortcut button to open MCEDesigner.
- Open the MCEDesigner default configuration file (.irc) for IMD111T smart driver (IMD111T_V1.03.01.irc included in the firmware zip folder downloaded from the Infineon website).
- Select the available COM port in “Performance > Connection” pop-up window.

The MCEDesigner window appears as shown in Figure 6.

For the next step, you need to program the firmware (.ldf file) and parameters (.txt file) into flash.

- Click on the “Tools” menu in the “System” window and select “Programmer” from the pull-down list.
- Choose the relevant ldf file and text file.
- Then click the Start button to program the ldf and text files.

EVAL-M7-LVMOS-INV user guide

Evaluation power board with M7 connector

System and functional description

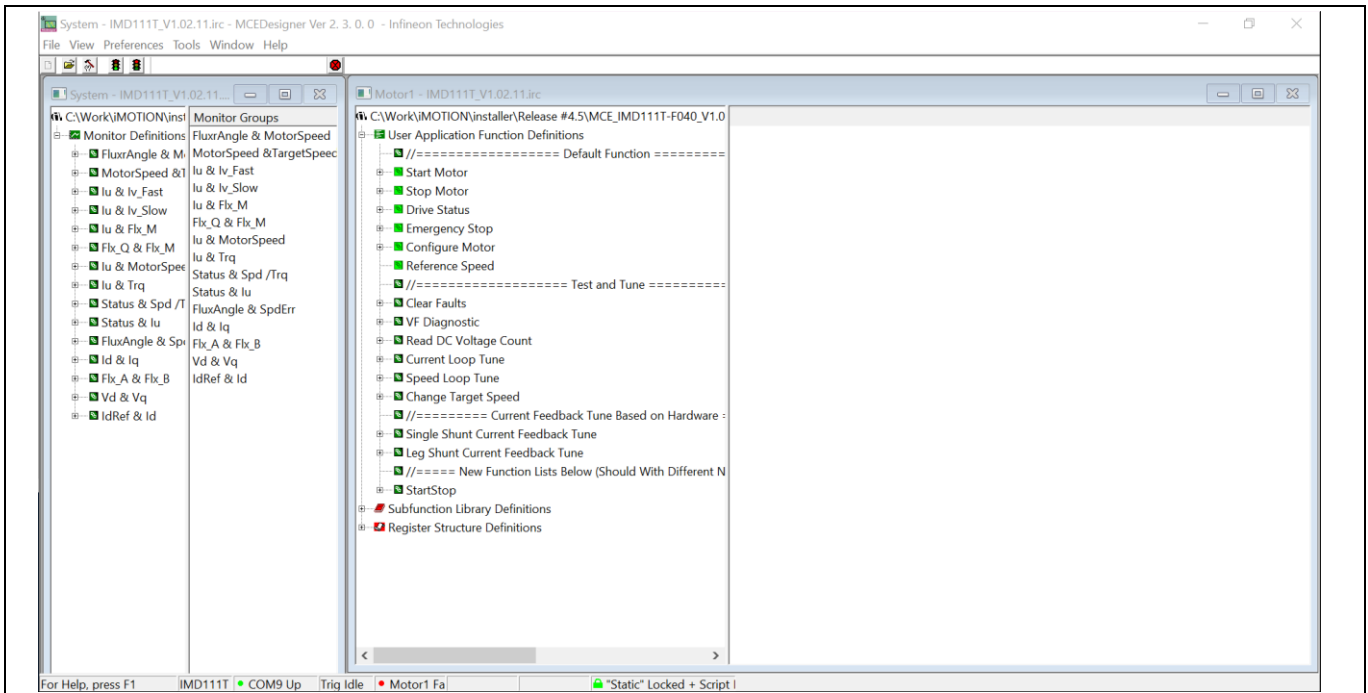

Figure 6 MCEDesigner window page

The ldf file can be downloaded from the Infineon website. The txt file was created by the MCEWizard as described in Chapter 2.2.1.1. The programming window is shown in Figure 7 below.

After the firmware and parameters are programmed, the system will be ready to run the motor. You can click the green traffic light to start the motor, or click the red traffic light to stop the motor. You can now check the waveform of phase current, Flx_M, motor speed, and other registers' values by double-clicking the monitor items in the system window.

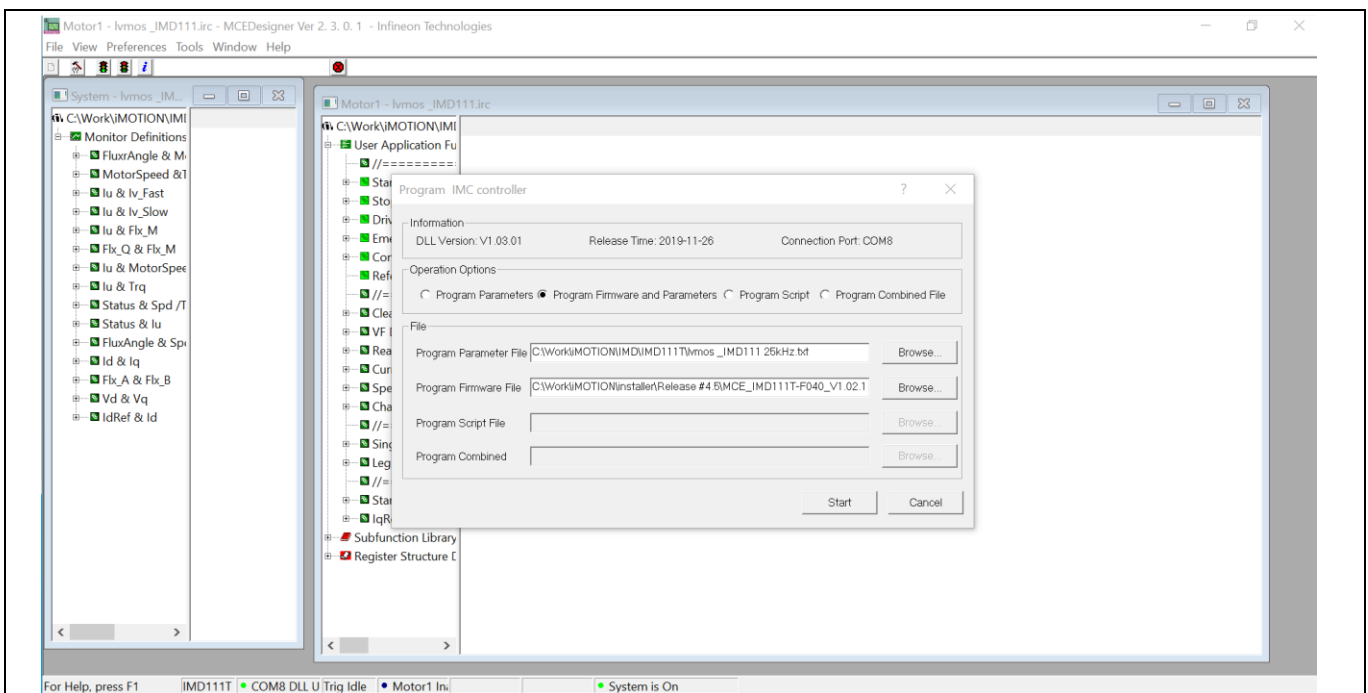

Figure 7 Programming window

2.3 Description of the functional blocks

This chapter covers the hardware design of the EVAL-M7-LVMOS-INV in more detail, so that users can understand the functional groups of this power board and use the board to easily evaluate performance. And it is also helpful for users to develop their solution based on the evaluation board design.

2.3.1 EVAL-M7-LVMOS-INV functional groups

Figure 8 depicts the evaluation board of EVAL-M7-LVMOS-INV functional group.

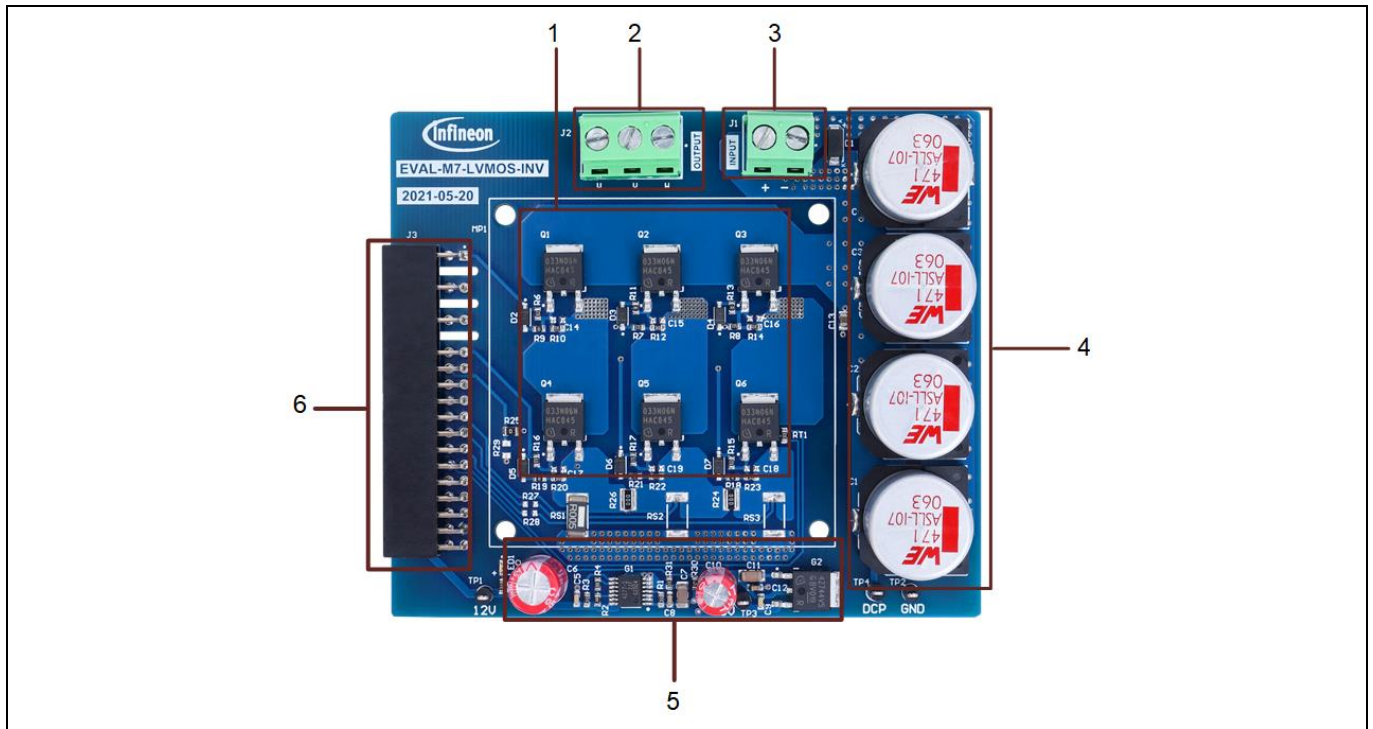

Figure 8 Functional groups

1. Inverter function (Q1~Q6)
2. Inverter output connector (J2)
3. DC input connector (J1)
4. Bus capacitors (C1~C4)
5. Auxiliary power supply (G1, G2)
6. M7 connector (J3)

2.3.2 Bus voltage feedback

EVAL-M7-LVMOS-INV evaluation board includes bus voltage feedback circuitry. It is a voltage divider. The high-side resistor R30 is 120 k Ω , and the low-side resistor (R31) is composed of one 10 k Ω . Figure 9 shows the bus voltage feedback on the board. Make sure the low-side resistor is on this power board, which is different from some other power boards that have the low-side resistor on the control board. The control board EVAL-M7-D111T has no low-side resistor, but only a decoupling capacitor, which is located near the input pin of the IMD111T bus voltage feedback. If users use a different control board, they should keep in mind the location of the low-side resistor, and make sure to get the correct feedback voltage.

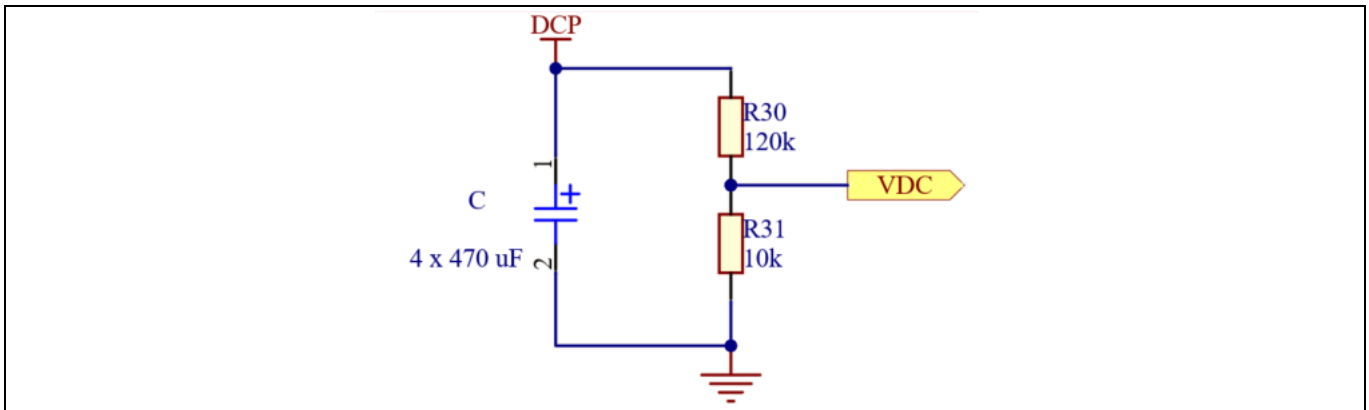

Figure 9 Bus voltage feedback

2.3.3 Current feedback configuration

There are two current feedback configurations on this EVAL-M7-LVMOS-INV power board. One is a single-shunt current feedback configuration. The other is a leg-shunt current feedback configuration. The single-shunt configuration is the default setting on the board. If users want to use a leg-shunt configuration, they should remove the resistors R24, R25, and R26 first. Then they should solder the resistors R27, R28, R29, RS2, and RS3. The value is 0 Ω for R27, R28, and R29. RS2 and RS3 are 5 mΩ. Please refer to the schematics for more details in Chapter 3.

Figure 10 shows the single-shunt current-sensing circuit. According to the explanation in MCEWizard for Question 83, the current input scaling can be calculated as:

$$\text{Current input scaling} = G_{ext} \times R_s = \frac{R_{12}}{R_{15} + R_{12}} \times R_{S1} = \frac{22.1}{2 + 22.1} \times 5 = 4.59 \text{ mA/V}$$

And the offset voltage calculated is:

$$V_{off} = \frac{R_{15}}{R_{15} + R_{12}} \times V_{DD} = \frac{2}{2 + 22.1} \times 5 = 0.415 \text{ V} = 415 \text{ mV}$$

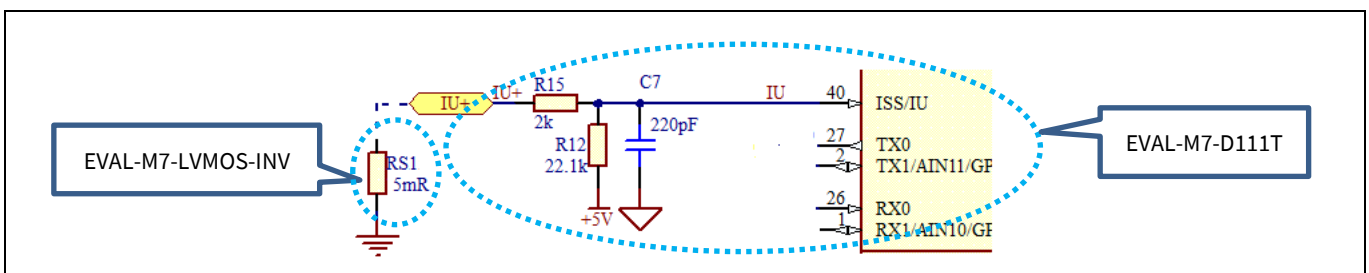

Figure 10 Current sensing for single shunt

2.3.4 Temperature measured with NTC on board

In order to measure the case temperature of the MOSFET switch, an NTC was assembled on the board near the W-phase, low-side MOSFET. The NTC resistor RT1 was placed on the board as shown in Figure 11. It is very close to the MOSFET. But there is a little gap between the NTC and MOSFET case. So there will be a difference between the measured case temperature and the real MOSFET case temperature. The pull-up resistor on the EVAL-M7-D111T control board is 4.87 kΩ. The connection between the NTC and control board is shown in Figure 11.

EVAL-M7-LVMOS-INV user guide

Evaluation power board with M7 connector

System and functional description

According to the NTC datasheet, Table 5 gives the NTC resistance values at intermediate temperature in case users want to calculate the divider voltage.

According to the connection shown in Figure 11, the NTC character on the board has been tested to observe the relationship between the dropped voltage of the NTC resistor and the maximum MOSFET case temperature. In this way, users can get the hottest MOSFET temperature by measuring the NTC dropped voltage. And they can also set the over-temperature threshold that they want to protect the system. Table 5 shows the test results for the NTC dropped voltage and case temperature.

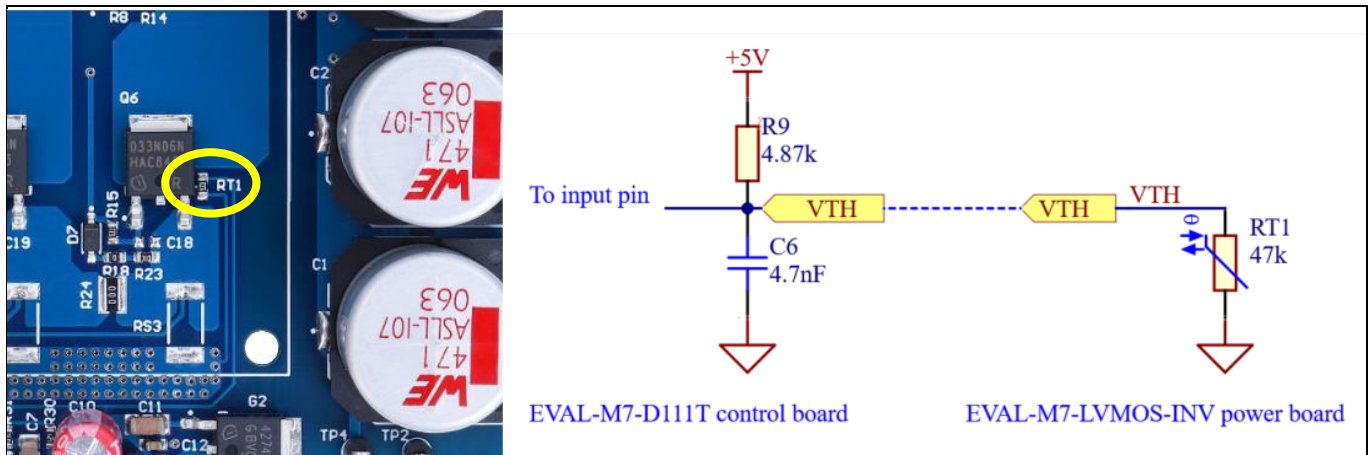

Figure 11 NTC placed on the board and voltage divider circuit

Table 5 NTC resistance values at intermediate temperature

T_{OPER} (°C)	15	20	25	30	35	40	45	50	55	60
R_T (k Ω)	74.4	58.95	47.00	37.71	30.43	24.70	20.15	16.53	13.63	11.30
T_{OPER} (°C)	65	70	75	80	85	90	95	100	105	110
R_T (k Ω)	9.404	7.865	6.607	5.573	4.721	4.015	3.427	2.936	2.525	2.179

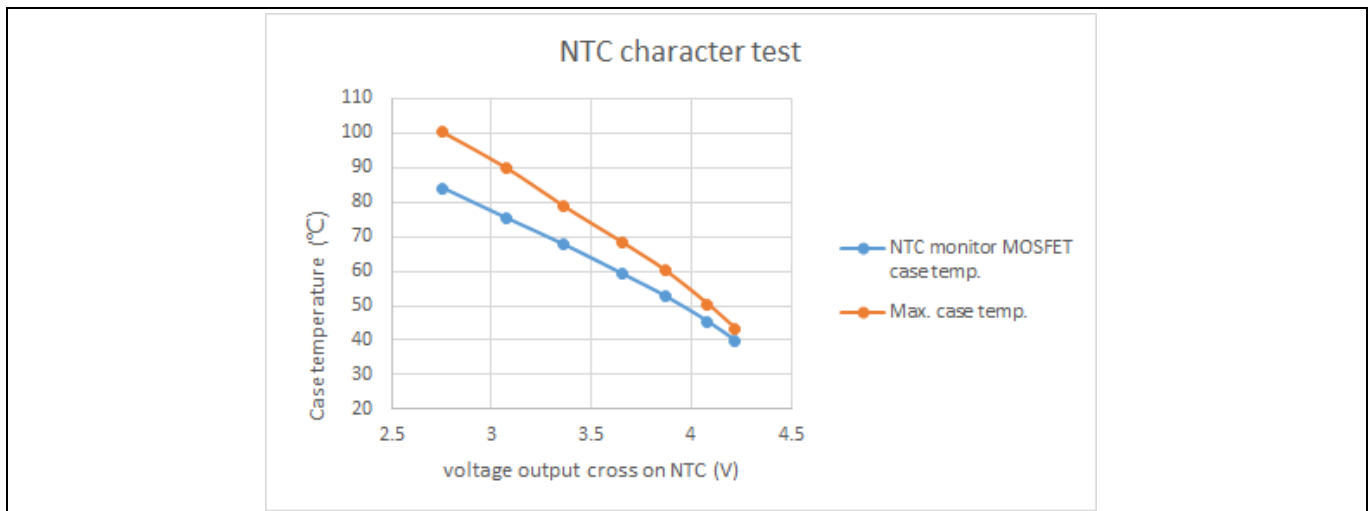

Figure 12 NTC character test on the board

EVAL-M7-LVMOS-INV user guide
Evaluation power board with M7 connector
System and functional description

2.3.5 DC power supply

This evaluation board EVAL-M7-LVMOS-INV is dedicated to motor applications with low-voltage DC input. The target power is under 300 W. For the same power rating, low-voltage bus applications need more current from the DC source than high-voltage bus applications. So users should consider the current ripple of the bus capacitors carefully. When the capacitor works at the higher current ripple than rated value, it can increase the temperature of the capacitor and shorten the life time. Four 470 μ F capacitors used on the board can compensate the DC bus ripple current. Figure 13 shows the waveform of the DC bus voltage and motor phase current.

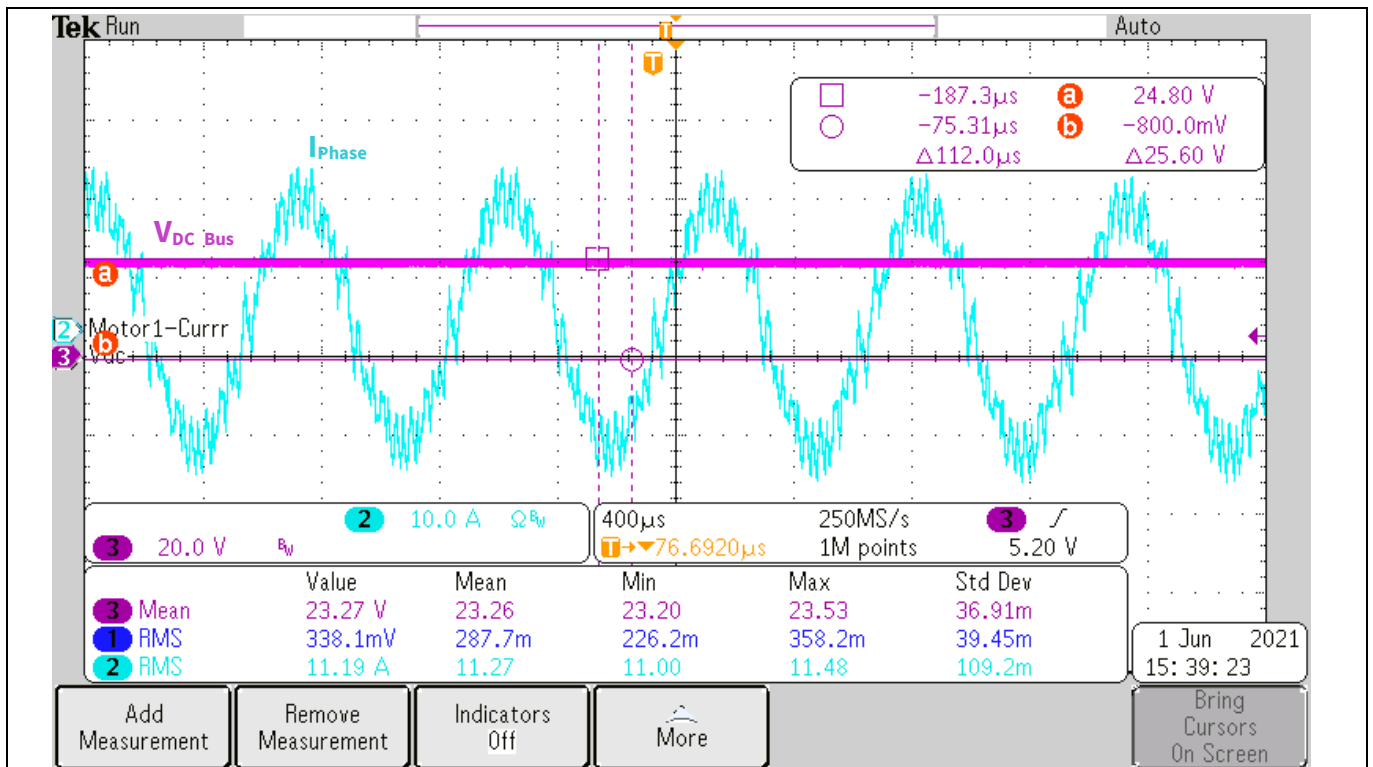

Figure 13 DC bus voltage and phase current

EVAL-M7-LVMOS-INV user guide

Evaluation power board with M7 connector

System and functional description

2.3.6 Protection function

For this power board EVAL-M7-LVMOS-INV, there is no external hardware protection function on the board. Protection functions such as overcurrent, over-/undervoltage, phase loss, and rotor lock are all carried out by the control board when using the EVAL-M7-D111T control board for evaluation. The overcurrent and over-/undervoltage protection threshold can be set in the MCEWizard. Users can also enable/disable the protection functions such as phase loss, rotor lock, etc. All the protection functions that are included in the IMD111T can be set in the MCEWizard. Figure 14 shows the overcurrent trip level setting page in MCEWizard.

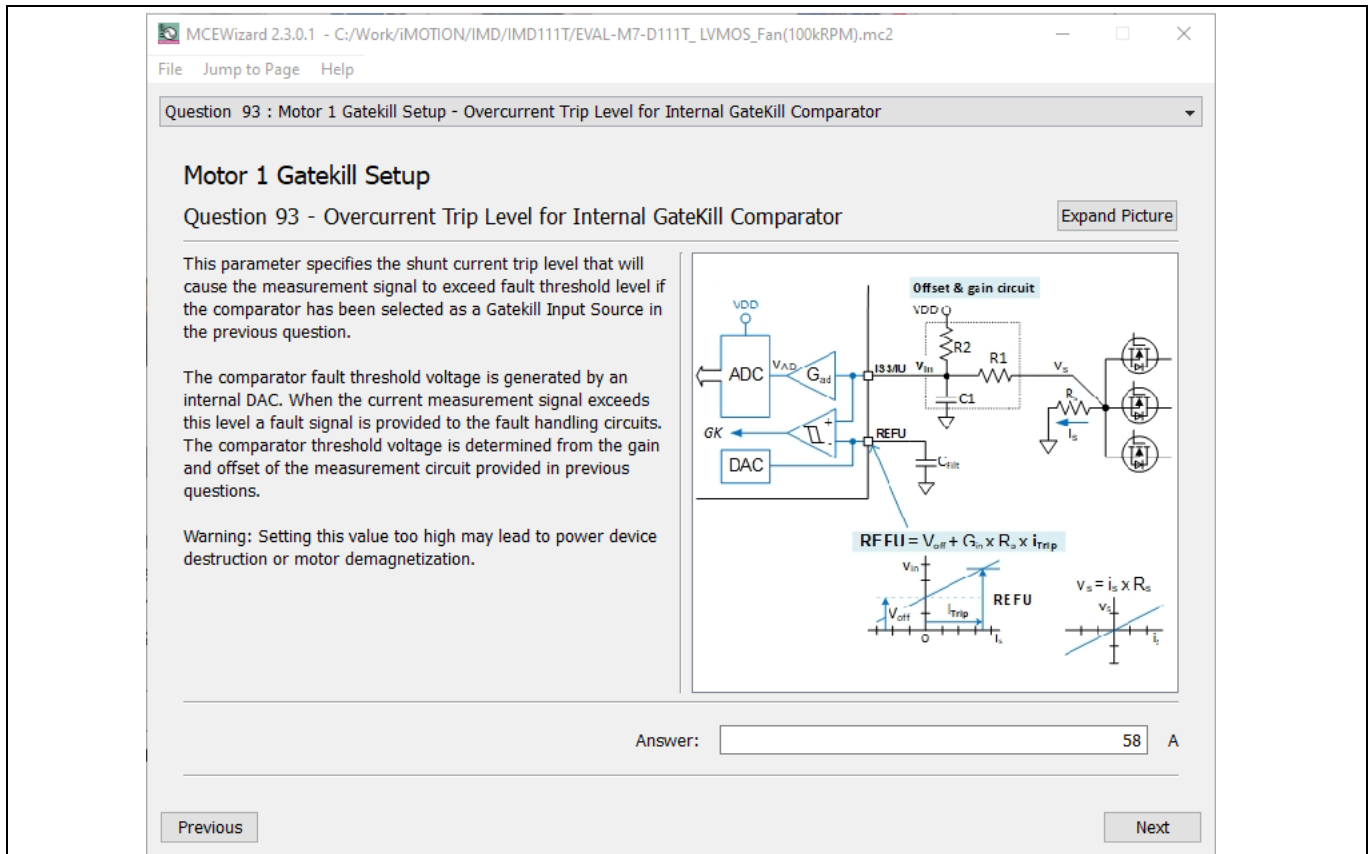

Figure 14 Overcurrent trip level setting in MCEWizard

System design

3 System design

3.1 Schematics

The schematics of EVAL-M7-LVMOS-INV power board include the DC voltage input, inverter section, and auxiliary power supply. Figure 15 shows the inverter section schematics of the EVAL-M7-LVMOS-INV. Figure 16 depicts the auxiliary power supply schematics. The power supply has two outputs: 15 V and 5 V. The 5 V output is an option when the EVAL-M7-D111T control board is used.

The complete schematic diagrams are available on the download section of the Infineon homepage. A log-in is required to download this material.

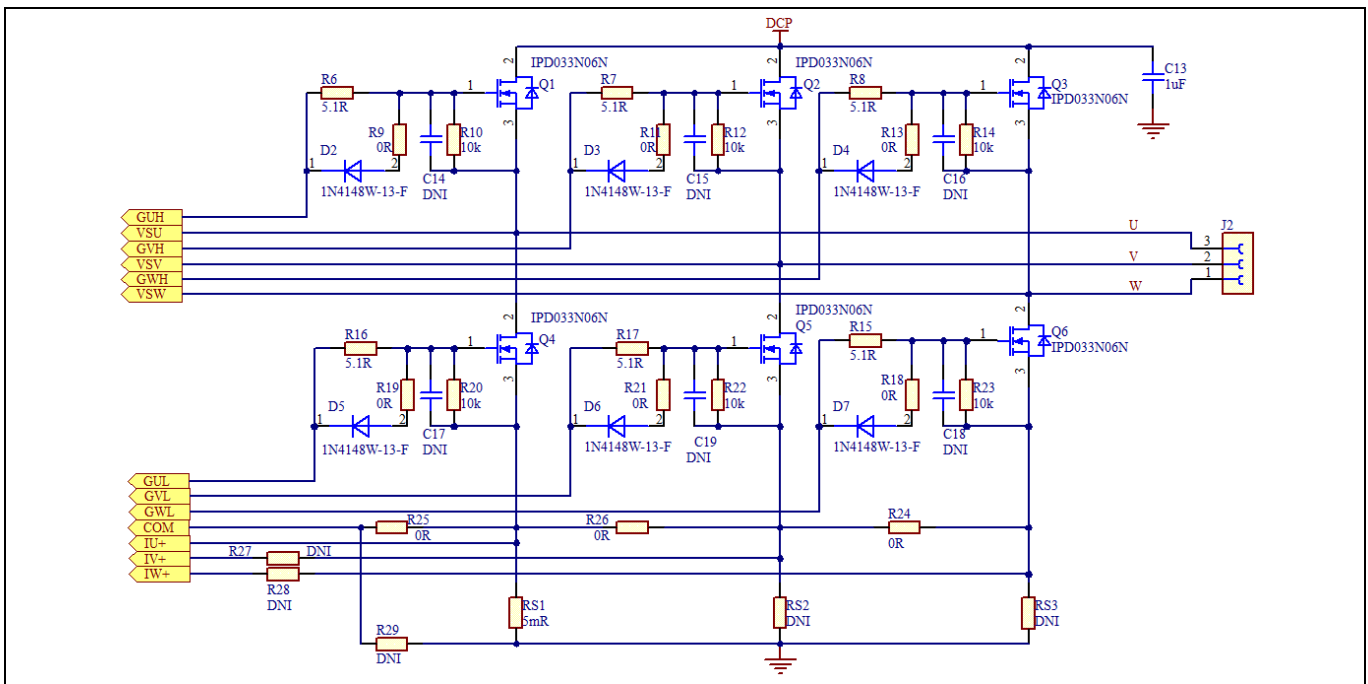

Figure 15 Inverter section schematics

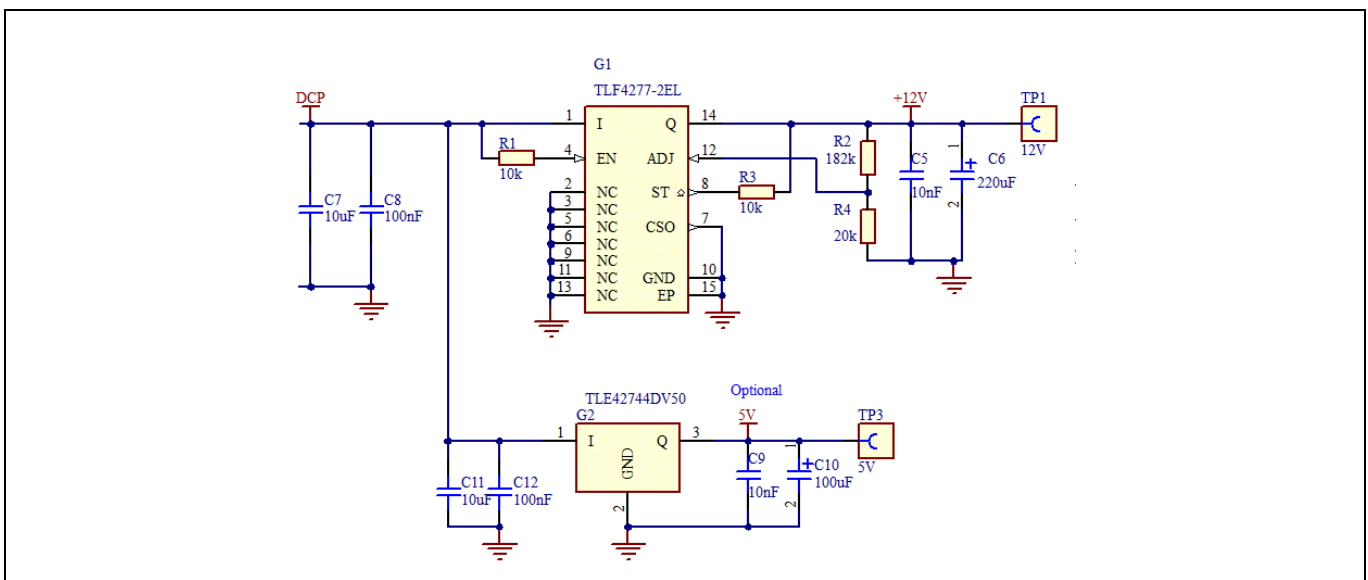

Figure 16 Auxiliary power supply

System design

3.2 Layout

The EVAL-M7-LVMOS-INV board consists of two copper PCB layers. The copper thickness is 35 μm and the board size is 80 mm x 93 mm. The board material is FR4 grade with 1.6 mm thickness. Check Infineon's website or contact Infineon's technical support team for more detailed information. The Gerber files are available on the download section of the Infineon homepage. A log-in is required to download this material.

The top layer and bottom layer PCB layout are shown in Figure 17 and Figure 18. For the power board PCB layout, users should connect the signal ground and power ground at one single point to keep low noise for the current-feedback sensing. The current-feedback trace should be short and close to ground copper. This can ensure that less noise is introduced into the current feedback loop. Lower current feedback noise is beneficial to motor control performance.

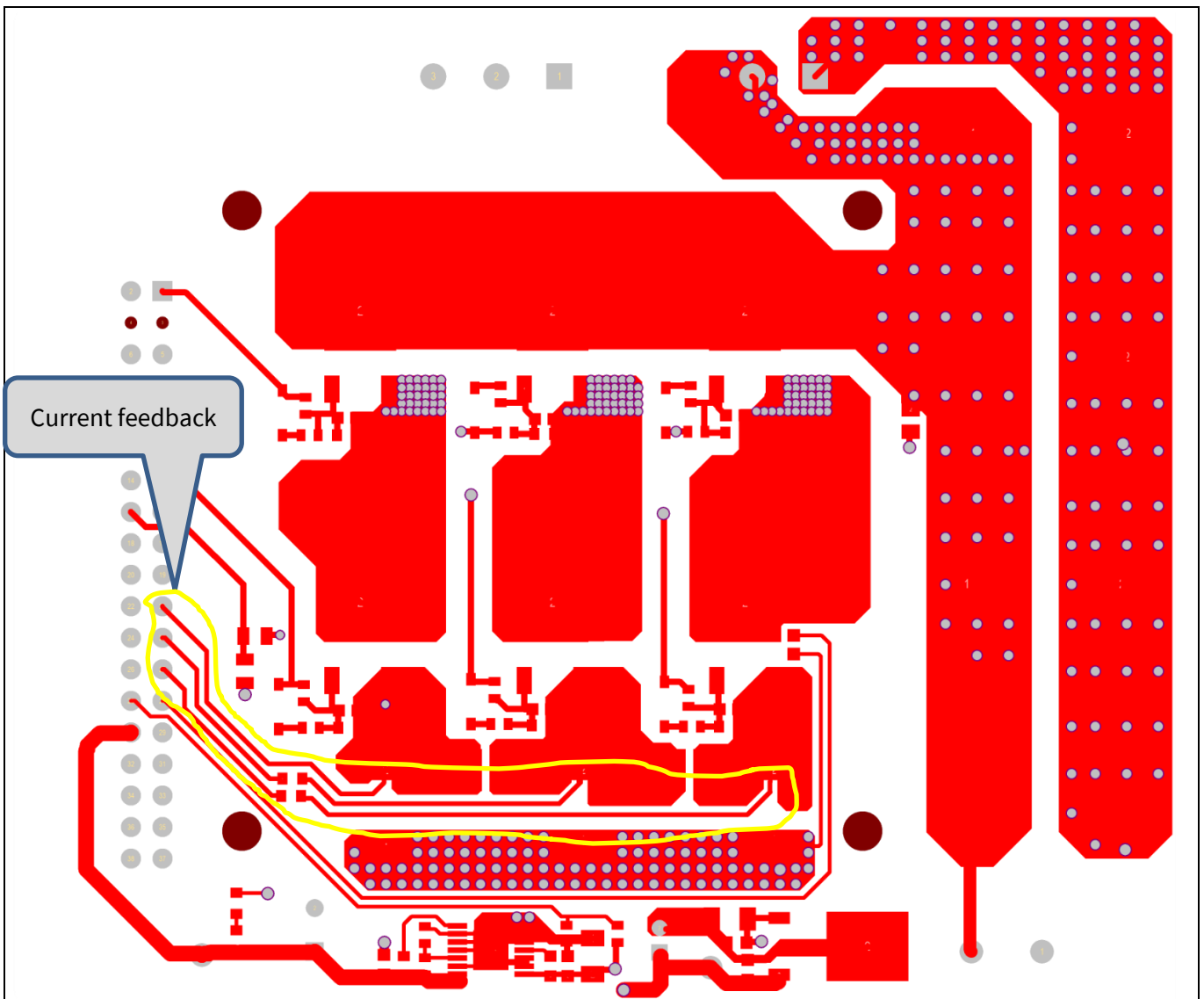

Figure 17 Top layer

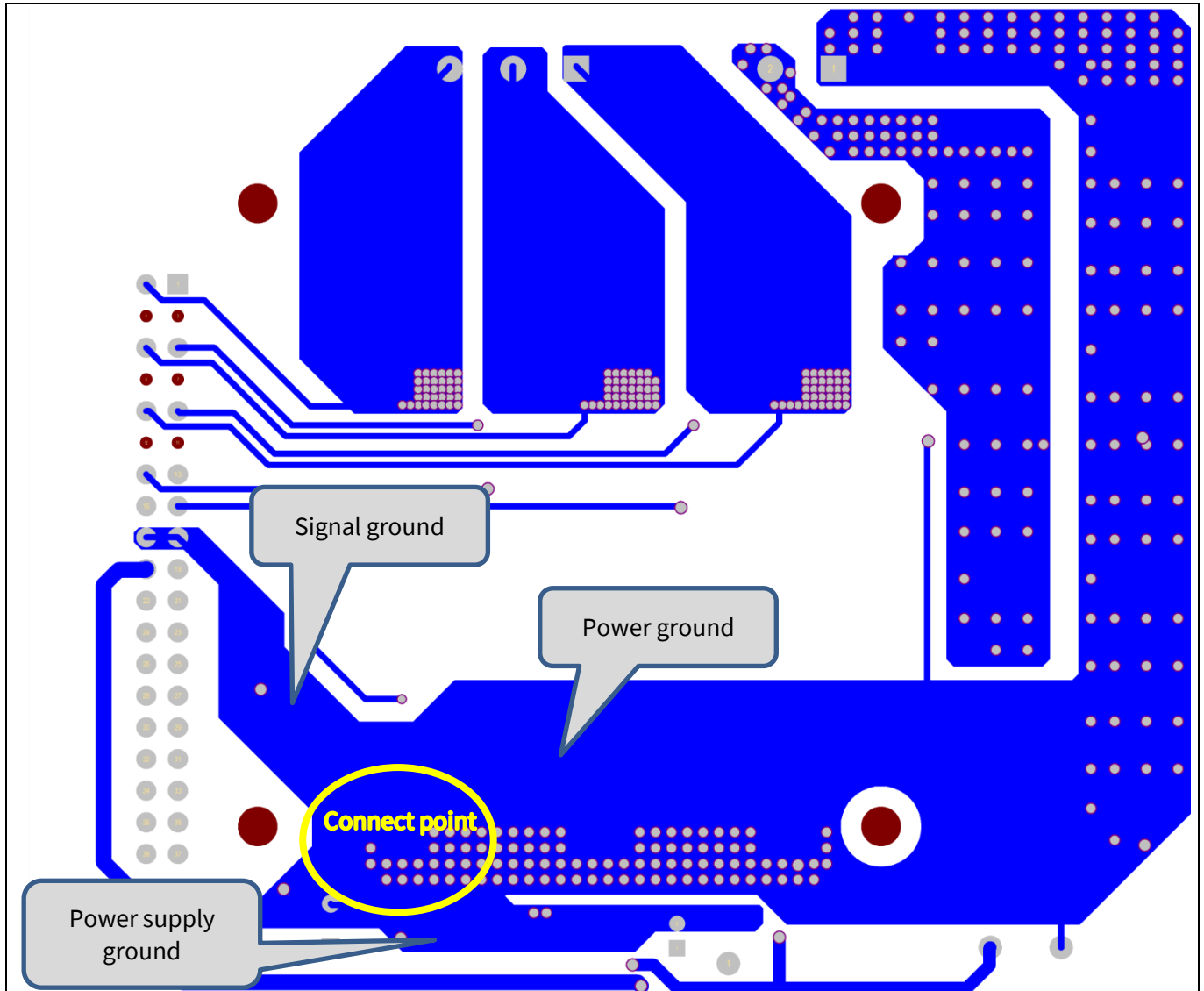

Figure 18 Bottom layer

3.3 Bill of material

The complete bill of material is available on the download section of the Infineon homepage. A log-in is required to download this material. Table 6 is the BOM of EVAL-M7-LVMOS-INV board.

Table 6 BOM of the evaluation board EVAL-M7-LVMOS-INV

S. No.	Ref Designator	Description	Manufacturer	Manufacturer P/N
1	C1, C2, C3, C4	CAP / ELCO / 470uF / 63V / 20% / Aluminium electrolytic / -55°C to 105°C / 17.10mm L X 17.10mm W X 17.00mm H / SMD / -	Würth Elektronik	865060763010
2	C5, C9	CAP / CERA / 10nF / 50V / 10% / X7R (EIA) / -55°C to 125°C / 0603 / SMD / -	AVX	06035C103K4Z2A
3	C6	CAP / ELCO / 220uF / 35V / 20% / Aluminium electrolytic / -40°C to 105°C / 3.50mm C X	Würth Elektronik	860020574012

EVAL-M7-LVMOS-INV user guide

Evaluation power board with M7 connector



System design

S. No.	Ref Designator	Description	Manufacturer	Manufacturer P/N
		0.60mm W 8.00mm Dia X 13.00mm H / THT / -		
4	C7, C11	CAP / CERA / 10uF / 50V / 20% / X5R (EIA) / -55°C to 85°C / 1206 (3216) / SMD / -	Taiyo Yuden	UMK316BBJ106ML-T
5	C8, C12	CAP / CERA / 100nF / 50V / 10% / X7R (EIA) / -55°C to 125°C / 0603 / SMD / -	AVX	06035C104KAT2A
6	C10	CAP / ELCO / 100uF / 16V / 20% / Aluminium electrolytic / - 40°C to 85°C / 2.00mm C X 0.50mm W 5.00mm Dia X 12.50mm H / THT / -	Würth Elektronik	860010473007
7	C13	CAP / CERA / 1uF / 50V / 10% / X7R (EIA) / -55°C to 125°C / 0805 / SMD / -	TDK Corporation	CGA4J3X7R1H105K125A B
8	C14, C15, C16, C17, C18, C19	CAP / CERA / 470pF / 50V / 10% / X7R (EIA) / -55°C to 125°C / 0603 (1608) / SMD / -	Würth Elektronik	885012206081
9	D1	SMAJ Transient Voltage Suppressor Diode Series	Bourns	SMAJ45A
10	D2, D3, D4, D5, D6, D7	Surface Mount Fast Switching Diode	Diodes Incorporated	1N4148W-13-F
11	G1	Low Drop Out Linear Voltage Regulator with Integrated Current Monitor	Infineon Technologies	TLF4277-2EL
12	G2	Low Dropout Linear Voltage Regulator, 5.0 V Output	Infineon Technologies	TLE42744DV50
13	J1	Horizontal Cable Entry With Rising Cage Clamp - WR-TBL, 2 Pins	Würth Elektronik	691216510002S
14	J2	Horizontal Cable Entry With Rising Cage Clamp - WR-TBL, 3Pins	Würth Elektronik	691216510003S
15	J3	The part can be named as M7- 38-F, Connector, 38 pins, 2.54 mm pitch, Board to Board, Right Angle	Sullins	PPTC192LJBN-RC
16	LED1	Standard 0603 SMD LED, 2.1V Red, Luminous Intensity 63 mcd	Vishay	TLMS1100-GS08
17	Q1, Q2, Q3, Q4, Q5, Q6	OptiMOS Power-Transistor, 60V	Infineon Technologies	IPD033N06N
18	R1	RES / - / 10k / 100mW / 5% / 200ppm/K / - / 0603 / SMD / -	ROHM Semiconductors	MCR03EZPJ103
19	R2	RES / STD / 182k / 100mW / 1% / 100ppm/K / -55°C to 155°C / 0603 / SMD / -	Vishay	CRCW0603182KFK
20	R3, R5, R10, R12, R14, R20, R22, R23	RES / STD / 10k / 100mW / 1% / 100ppm/K / -55°C to 155°C / 0603 / SMD / -	Yageo	RC0603FR-0710KL
21	R4	RES / STD / 20k / 100mW / 1% / 100ppm/K / -55°C to 155°C / 0603 / SMD / -	Vishay	CRCW060320K0FK

System design

S. No.	Ref Designator	Description	Manufacturer	Manufacturer P/N
22	R6, R7, R8, R15, R16, R17	RES / STD / 5.1R / 100mW / 1% / 100ppm/K / -55°C to 155°C / 0603 / SMD / -	Vishay	CRCW06035R10FK
23	R9, R11, R13, R18, R19, R21	RES / STD / 0R / - / 0R / - / -55°C to 155°C / 0603 / SMD / -	Vishay	CRCW06030000Z0
24	R24, R26	RES / - / 0R / 500mW / - / - / - / 0612 / SMD / -	Vishay	RCL06120000Z0EA
25	R25	RES / STD / 0R / 125mW / 0R / 0ppm/K / -55°C to 155°C / 0805 / SMD / -	Yageo	RC0805JR-070RL
26	R27, R28	RES / STD / 0R / 100mW / 0R / 0ppm/K / -55°C to 155°C / 0603 / SMD / -	Yageo	RC0603JR-070RL
27	R29	RES / STD / 0R / 125mW / 0R / 0ppm/K / -55°C to 155°C / 0805 / SMD / -	Yageo	RC0805JR-070RL
28	R30	RES / STD / 120k / 100mW / 1% / 100ppm/K / -55°C to 155°C / 0603 / SMD / -	Vishay	CRCW0603120KFK
29	R31	RES / STD / 10k / 100mW / 1% / 100ppm/K / -55°C to 155°C / 0603 / SMD / -	Vishay	CRCW060310K0FK
30	RS1	RES / STD / 5mR / 3W / 1% / 75ppm/K / -65°C to 170°C / 2512 / SMD / -	Panasonic	ERJMS4HF5M0U
31	RS2, RS3	RES / STD / 5mR / 3W / 1% / 75ppm/K / -65°C to 170°C / 2512 / SMD / -	Panasonic	ERJMS4HF5M0U
32	RT1	RES / STD / 47k / 125mW / 3% / - / -40°C to 150°C / 0603 / SMD / -	Vishay	NTCS0603E3473HHT
33	TP1, TP2, TP3, TP4	Test Point THT, Black	Keystone Electronics Corp.	5001

3.4 Connector details

There are 3 connectors on the EVAL-M7-LVMOS-INV board. All connector pin assignments are described in Table 7 to Table 9.

Table 7 DC input connector-J1

Pin Number	Symbol	Assignment
1	-	DC input negative
2	+	DC input positive

System design

Table 8 Inverter output connector-J2

Pin Number	Symbol	Assignment
1	W	W phase output
2	V	V phase output
3	U	U phase output

Table 9 M7 connector-J3

Pin Number	Symbol	Assignment
1	GUH	U phase high-side gate PWM
2	VSV	U phase high-side floating return
3, 4, 7, 8, 11, 12	-	Not used.
5	GVH	V phase high-side gate PWM
6	VSV	V phase high-side floating return
9	GWH	W phase high-side gate PWM
10	VSW	W phase high-side floating return
13	GUL	U phase low-side gate PWM
14	GVL	V phase low-side gate PWM
15	GWL	W phase low-side gate PWM
16	COM	Gate driver low-side return
17, 18, 32	GND	Ground
19	VDD	Internal LDO output
20	VDD1	External VDD supply voltage
21	IU+	U phase current-sensing signal positive
22	IU-	U phase current-sensing signal negative
23	IV+	V phase current-sensing signal positive
24	IV-	V phase current-sensing signal negative
25	IW+	W phase current-sensing signal positive
26	IW-	W phase current-sensing signal negative
27	VTH	Negative temperature coefficient (NTC) resistor output voltage
28	VDC	V _{bus} voltage sensing
29	GK	Inverter gate kill signal
30	VCC	Gate driver supply voltage
31	PFCG0	PFC gate driving PWM 0 (not used for this board)
33	PFCG1	PFC gate driving PWM 1 (not used for this board)
34	PFCGK	PFC gate kill signal (not used for this board)
35	IPFC+	PFC current-sensing positive (not used for this board)
36	IPFC-	PFC current-sensing negative (not used for this board)
37	VAC1	AC voltage-sensing input 1 (not used for this board)
38	VAC2	AC voltage-sensing input 2 (not used for this board)

4 System performance

4.1 dv/dt test

The dv/dt is important for the motor control system. The motor application requires the dv/dt to be below 5 V/ns. This can improve motor-control reliability. But please note that lower dv/dt will increase the MOSFET switching losses. The turn-on dv/dt of the EVAL-M7-LVMOS-INV board is measured at 0.74 V/ns when using the EVAL-M7-D111T control board. The dv/dt is a bit lower due to the IMD111T driving capability limitation, and the MOSFET IPD033N06N has a bigger gate charge (Q_{GS}). The turn-on gate resistor is 5.1 Ω . Figure 19 depicts the dv/dt test waveform. Please note that if users have other control boards to drive this evaluation board EVAL-M7-LVMOS-INV, they should check the dv/dt to make sure it is less than 5 V/ns. An additional capacitor space, which is paralleled with the G-S pin of the MOSFET, is reserved to slow down the switching speed if dv/dt cannot meet the requirement when user only changes gate resistor.

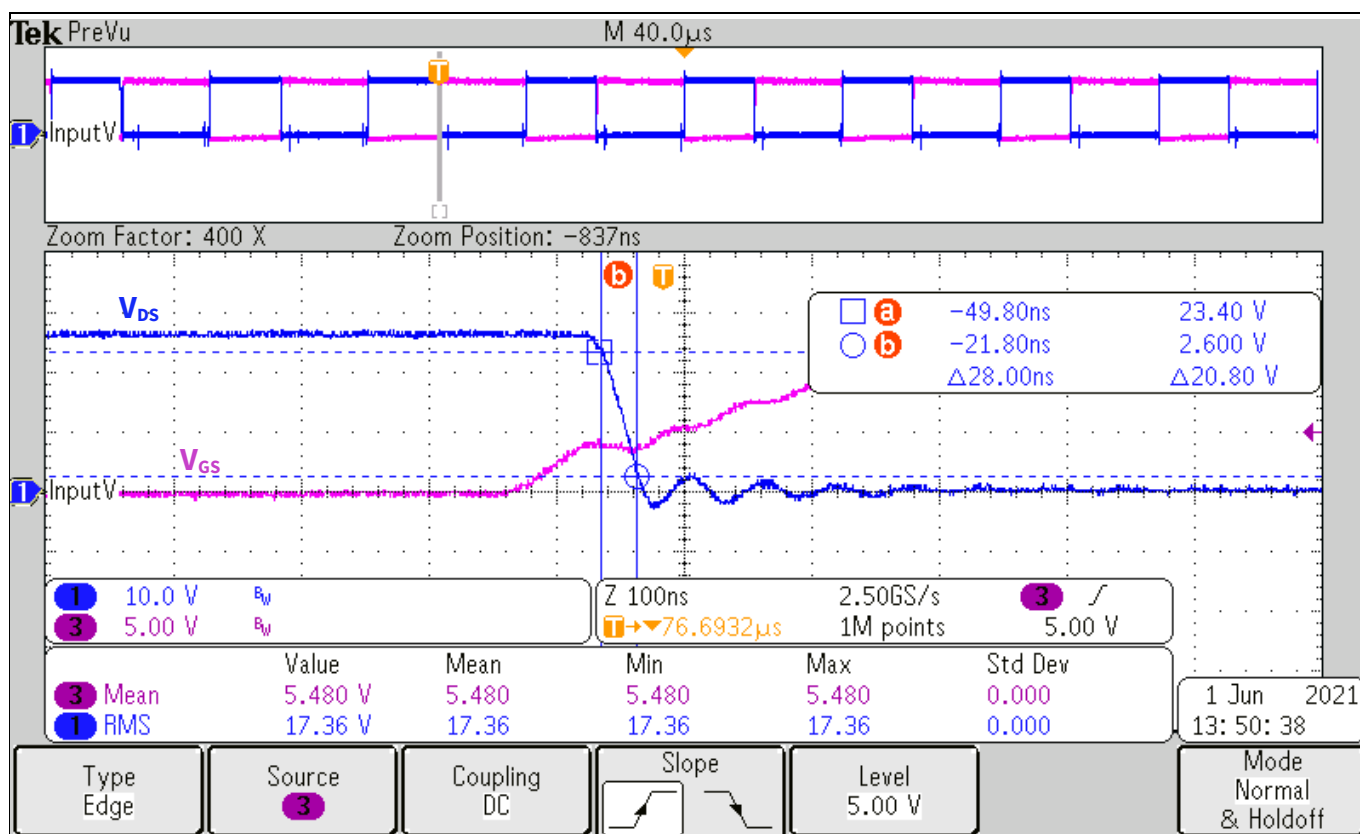

Figure 19 EVAL-M7-LVMOS-INV dv/dt test waveform

4.2 Thermal performance test

For the EVAL-M7-LVMOS-INV power board thermal performance test, the input power and motor-phase current were measured when the MOSFET case temperature was increased to 100 °C. The power board was tested in different carrier frequencies. The PWM frequency range is from 15 kHz to 25 kHz under testing conditions. Keep in mind, however, that this power board can be run up to 40 kHz; the output power capability will drop down accordingly. Figure 20 shows a thermal test snapshot at 24 V_{DC} input, 20 kHz carrier frequency, and 300 W input power. The hot point of the power board is 101.2 °C when the room temperature is 28 °C. Users can add a heatsink or cooling fan to increase the board output power. Space for a heatsink has been reserved on the board. If a heatsink is added, exercise caution when using a thermal pad.

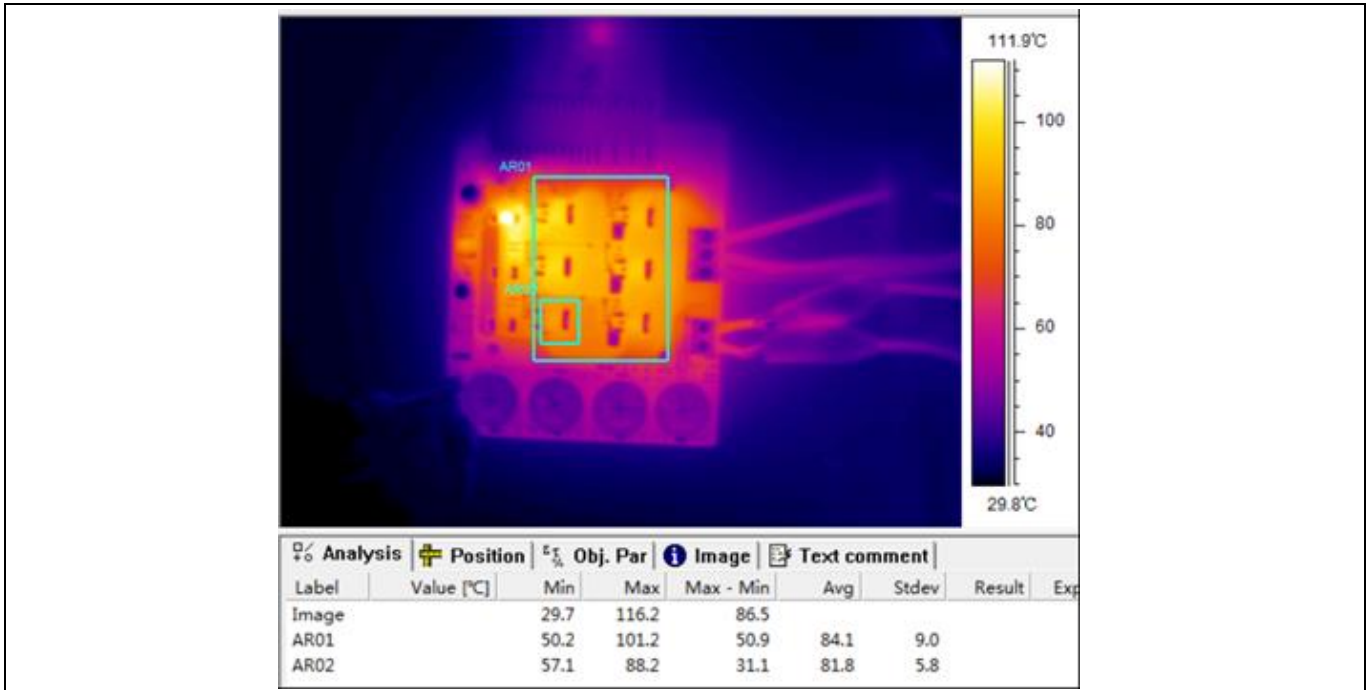

Figure 20 Thermal test

4.3 Test results

The output power capability of the EVAL-M7-LVMOS-INV power board was tested at different carrier frequencies. The MOSFET case temperature is up to 100°C under test conditions. All tests take place at room temperature 25°C and without heatsink or cooling fan. Figure 21 shows the increase of MOSFET case temperature in relation to input power at different PWM frequencies. Figure 22 shows the motor-phase current at different PWM frequencies.

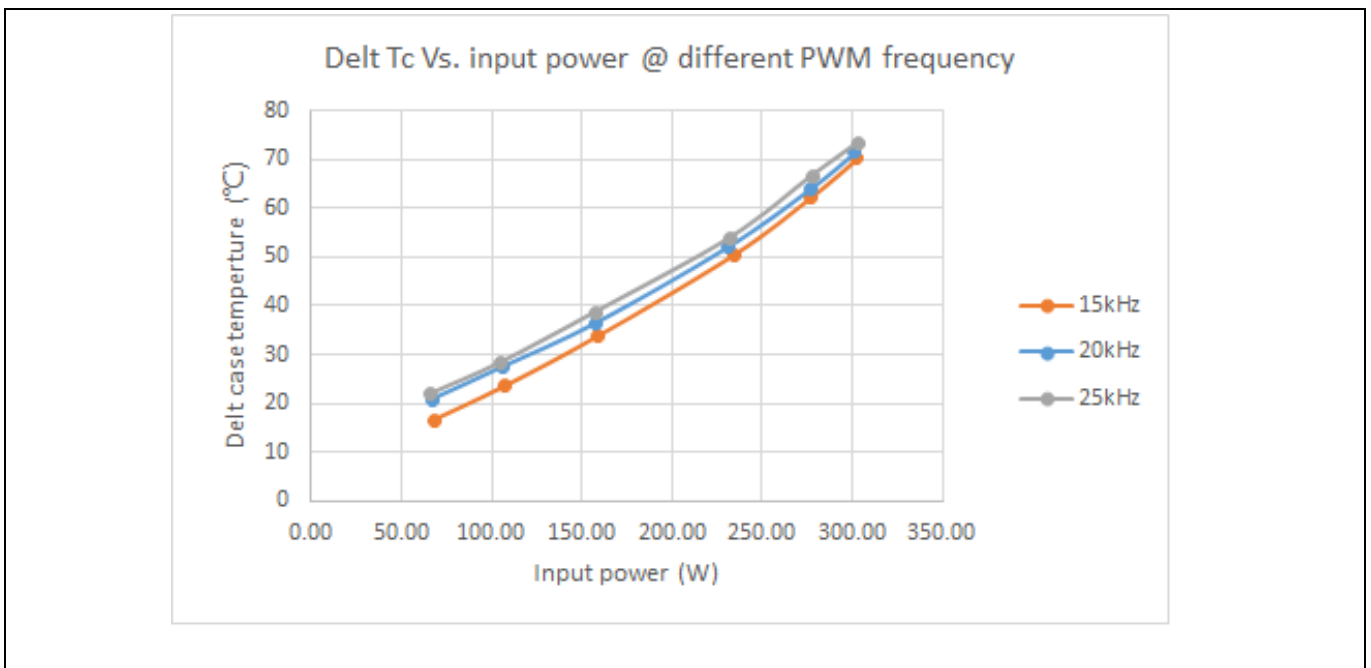

Figure 21 MOSFET ΔT_c vs. input power

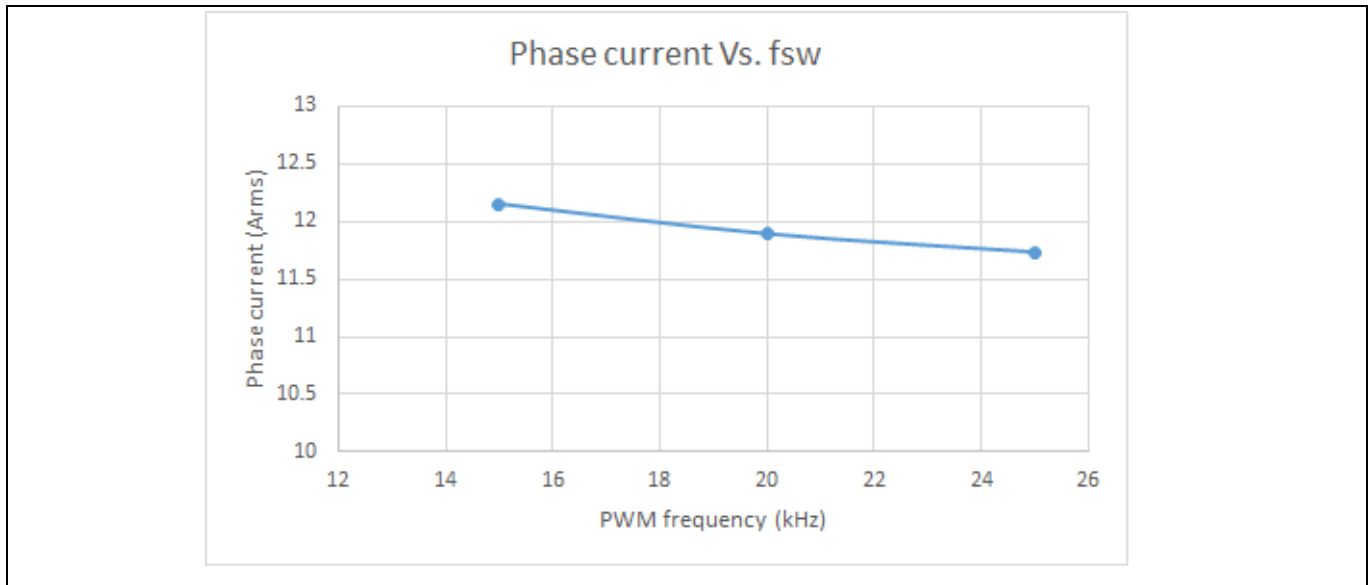

Figure 22 Phase current vs. carrier frequency

5 References and appendices

5.1 References

- [1] Infineon Technologies AG. Datasheet (2016): IPD033N06N - 60V OptiMOS™ Power-Transistor. V2.0 www.infineon.com
- [2] Infineon Technologies AG. Datasheet (2018): TLE42744DV50 - Low Dropout Linear Voltage Regulator. V1.3 WWW.infineon.com
- [3] Infineon Technologies AG. Datasheet (2014): TLF4277-2EL - Low Dropout Linear Voltage Regulator. V1.0 WWW.infineon.com
- [4] Vishay. Datasheet (2020): NTCS0603E3473HHT, NTC thermistors. V 14-Jan-2020. www.vishay.com
- [5] Infineon Technologies AG. User guide (2020): MCEWizard V2.3 user guide. V2.3 www.infineon.com
- [6] Infineon Technologies AG. AppNote (2020): MCEDesigner application guide. V2.3 www.infineon.com

5.2 Ordering details and other additional information

The board is now available for customers in small order quantities. Design data are available in the download section of the Infineon homepage. A log-in is required to download the material.

In order to initiate the testing, customers are advised to order this board from the link below:

Buy online: [link](#), or <https://www.infineon.com/madk>

Revision history

Document version	Date of release	Description of changes
V1.0	2021-7-20	First release
V1.01	2022-5-5	Correct the AC source to the DC source in chapter 2.2.1

Trademarks

All referenced product or service names and trademarks are the property of their respective owners.

Edition 2022-05-05

Published by

Infineon Technologies AG

81726 Munich, Germany

© 2022 Infineon Technologies AG.

All Rights Reserved.

Do you have a question about this document?

Email: erratum@infineon.com

Document reference

UG-2021-30

For further information on the product, technology, delivery terms and conditions and prices please contact your nearest Infineon Technologies office (www.infineon.com).



WARNINGS

Due to technical requirements products may contain dangerous substances. For information on the types in question please contact your nearest Infineon Technologies office.







Except as otherwise explicitly approved by Infineon Technologies in a written document signed by authorized representatives of Infineon Technologies, Infineon Technologies' products may not be used in any applications where a failure of the product or any consequences of the use thereof can reasonably be expected to result in personal injury.

Looking for pricing, stock, or lifecycle information?

Click below to explore more details on WIN SOURCE:

-  [View EVALM7LVMOSINVT0B01 on WIN SOURCE](#)
-  [Infineon Technologies Information](#)

Optimize Your Supply Chain with WIN SOURCE Solutions

-  Global Sourcing Solution
-  Obsolete Management
-  Cost Control Management
-  Shortage Management
-  Alternative Solution
-  Excess Inventory Management